

AQVSL-AQVSH STAR



English

Français

Deutsch

Italiano

Español



82
↓
157 kW



83
↓
168 kW



Air Cooled Water Chillers and Heat Pumps

Refroidisseurs de liquide à condensation par air et pompes à chaleur air-eau

Luftgekühlte Flüssigkeitskühler und Wärmepumpen

Refrigeratori d'Acqua e Pompe di Calore Raffreddati ad Aria

Enfriadores de Agua y Bomba de Calor Condensadas con Aire

IOM AQVS-N.2ALL

Part number / Code / Code / Codice / Código : **035B09040-500**

Supersedes / Annule et remplace / Annulliert und ersetzt / Annulla e sostituisce /

Anula y sustituye : **None / Aucun / Nicht / Nulla / Ninguno**

Notified Body / Organisme Notifié / Benannte Zertifizierungsstelle / Organismo

Notificato / Organismo Notificado N°. 1115 **PASCAL**



Table of Contents

1 - FOREWORD

1.1 Introduction.....	2
1.2 Warranty.....	2
1.3 Emergency stop/Normal stop.....	2
1.4 An introduction to this manual.....	2

2 - SAFETY

2.1 Foreword.....	3
2.2 Definitions.....	4
2.3 Access to the unit.....	4
2.4 General precautions.....	4
2.5 Precautions against residual risks.....	4
2.6 Precautions during maintenance operations.....	5
2.7 Safety labels.....	6 & 7
2.8 Safety regulations.....	8 to 10

3 - TRANSPORT, LIFTING AND POSITIONING

3.1 Inspection.....	11
3.2 Lifting.....	11
3.3 Anchoring.....	12
3.4 Storage.....	12

4 - INSTALLATION

4.1 Positioning of the unit.....	13
4.2 Spring Isolator Installation.....	13
4.3 External Water Circuit.....	14 to 21
4.4 Water connections.....	22
4.5 Defrost water drainage (only for AQVSH units).....	22
4.6 Power supply.....	22
4.7 Electrical connections.....	23
4.8 Connecting plate-type evaporator temperature sensors.....	23 & 24
4.9 Microchannel type condenser coils.....	25

5 - START-UP

5.1 Preliminary check.....	26
5.2 Start-up.....	26
5.3 Checking the operation.....	26
5.4 Delivery to the customer.....	26

6 - CONTROL

6.1 Control of AQVSL/AQVSH STAR with 2 compressors the "Chiller Control" system.....	27
6.2 Display.....	28
6.3 Keyboard.....	28 to 30
6.4 Protection and Safety Equipment.....	31

7 - PRODUCT DESCRIPTION

7.1 General Information.....	32
7.2 Body and Frame.....	32
7.3 Compressors.....	32
7.4 Evaporators.....	32
7.5 Condensing/evaporating coils.....	32
7.6 Condenser Fans.....	32
7.7 Fans Control.....	32
7.8 Refrigerating Circuit.....	32
7.9 Control Supply Panel.....	32

8 - TECHNICAL DATA

8.1 Pressure drops.....	35
8.2 Technical data.....	36 to 41
8.3 Unit electrical data.....	42 & 43
8.4 Hydraulic Features.....	44 to 46
8.5 Position of shock adsorbers and weight distribution on supports.....	47 & 48
8.6 Dimensional Drawings.....	49 & 50
8.7 Service spaces.....	51

9 - MAINTENANCE

9.1 General requirements.....	52
9.2 Planned maintenance.....	52
9.3 Refrigerant charge.....	53
9.4 Compressor.....	53
9.5 Condenser.....	53
9.6 Fans.....	53
9.7 Dehydrating filter.....	53
9.8 Sight glass.....	53
9.9 Mechanical expansion valve.....	54
9.10 Evaporator.....	54

10 - TROUBLESHOOTING

11 - SPARE PARTS

11.1 Spare part list.....	56
11.2 Oil for compressors.....	56
11.3 Wiring diagrams.....	56

12 - DISMANTLING, DEMOLITION AND SCRAPPING

12.1 Generalities.....	57
------------------------	----

1 - Foreword

1.1 Introduction

Units, manufactured to state-of-the-art design and implementation standards, ensure top performance, reliability and fitness to any type of air-conditioning systems.

These units are designed for cooling water or glycoled water (and for water heating in heat pump models) and are unfit for any purposes other than those specified in this manual.

This manual includes all the information required for a proper installation of the units, as well as the relevant operating and maintenance instructions.

It is therefore recommended to read this manual carefully before installation or any operation on the machine. The chiller installation and maintenance must be carried out by skilled personnel only (where possible, by one of Authorised Service Centers).

The manufacturer may not be held liable for any damage to people or property caused by improper installation, start-up and/or improper use of the unit and/or failure to implement the procedures and instructions included in this manual.

1.2 Warranty

These units are delivered complete, tested and ready for being operated. Any form of warranty will become null and void in the event that the appliance is modified without manufacturer's preliminary written authorisation.

This warranty shall apply providing that the installation instructions have been complied with (either issued by manufacturer, or deriving from the current practice), and the Form 1 ("Start-up") has been filled-in and mailed to manufacturer (attn. After-Sales Service).

In order for this warranty to be valid, the following conditions shall be met :

- The machine must be operated only by skilled personnel from Authorised After-Sales Service.
- Maintenance must be performed only by skilled personnel - from one of Authorised After-Sales Centers.
- Use only original spare parts.
- Carry out all the planned maintenance provided for by this manual in a timely and proper way.

Failure to comply with any of these conditions will automatically void the warranty.

1.3 Emergency stop / Normal stop

The emergency stop of the unit can be enabled using the master switch on the control panel (move down the lever).





For a normal stop, press the relevant push-buttons.

To restart the appliance, follow the procedure detailed in this manual.

1.4 An introduction to the manual

For safety reasons, it is imperative to follow the instructions given in this manual. In case of any damage caused by non-compliance with these instructions, the warranty will immediately become null and void.

Conventions used throughout the manual :

	The Danger sign recalls your attention to a certain procedure or practice which, if not followed, may result in serious damage to people and property.
	The Warning sign precedes those procedures that, if not followed, may result in serious damage to the appliance.
	The Notes contain important observations.
	The Useful Tips provide valuable information that optimises the efficiency of the appliance.

This manual and its contents, as well as the documentation which accompanies the unit, are and remain the property of manufacturer, which reserves any and all rights thereon. This manual may not be copied, in whole or in part, without manufacturer's written authorization.

2 - Safety

2.1 Foreword

These units must be installed in conformity with the provisions of Machinery Directive 2006/42/EC, Low Voltage Directive 2006/95/EC, Pressure Vessels Directive 97/23/EC, Electromagnetic Interference Directive 2004/108/EC, as well as with other regulations applicable in the country of installation. If these provisions are not complied with, the unit must not be operated.

	<p>The unit must be grounded, and no installation and/or maintenance operations may be carried out before deenergising the electrical panel of the unit.</p>
---	--

Failure to respect the safety measures mentioned above may result in electrocution hazard and fire in the presence of any short-circuits.

	<p>Inside the heat exchangers, the compressors and the refrigeration lines, this unit contains liquid and gaseous refrigerant under pressure. The release of this refrigerant may be dangerous and cause injuries.</p>
---	--

	<p>The units are not designed to be operated with natural refrigerants, such as hydrocarbons. Manufacturer may not be held liable for any problems deriving from the replacement of original refrigerant or the introduction of hydrocarbons.</p>
---	---

Units are designed and manufactured according to the requirements of European Standard PED 97/23/EC (pressure vessels).

- The used refrigerants are included in group II (non-hazardous fluids).
- The maximum working pressure values are mentioned on the unit's data plate.
- Suitable safety devices (pressure switches and safety valves) have been provided, to prevent any anomalous overpressure inside the plant.
- The vents of the safety valves are positioned and oriented in such a way as to reduce the risk of contact with the operator, in the event that the valve is operated. Anyway, the installer will convey the discharge of the valves far from the unit.
- Dedicated guards (removable panels with tools) and danger signs indicate the presence of hot pipes or components (high surface temperature).

	<p>The guards of the fans (only for units provided with air heat exchangers) must be always mounted and must never be removed before de-energising the appliance.</p>
---	---

	<p>It is the User's responsibility to ensure that the unit is fit for the conditions of intended use and that both installation and maintenance are carried out by experienced personnel, capable of respecting all the recommendations provided by this manual.</p> <p>It is important that the unit is adequately supported, as detailed in this manual. Non-compliance with these recommendations may create hazardous situations for the personnel.</p>
---	---

	<p>The unit must rest on a base which meets the characteristics specified in this manual; a base with inadequate characteristics is likely to become a source of serious injury to the personnel.</p>
---	---

	<p>The unit has not been design to withstand loads and/or stress that may be transmitted by adjacent units, piping and/or structures.</p> <p>Each external load or stress transmitted to the unit may break or cause breakdowns in the unit's structure, as well as serious dangers to people. In these cases, any form of warranty will automatically become null and void.</p>
---	--

	<p>The packaging material must not be disposed of in the surrounding environment or burnt.</p>
---	--

2 - Safety (continued)

2.2 Definitions

OWNER : means the legal representative of the company, body or individual who owns the plant where unit has been installed; he/she has the responsibility of making sure that all the safety regulations specified in this manual are complied with, along with the national laws in force.

INSTALLER : means the legal representative of the company who has been given by the owner the job of positioning and performing the hydraulic, electric and other connections of unit to the plant: he/she is responsible for handling and properly installing the appliance, as specified in this manual and according to the national regulations in force.

OPERATOR : means a person authorised by the owner to do on unit all the regulation and control operations expressly described in this manual, that must be strictly complied with, without exceeding the scope of the tasks entrusted to him.

ENGINEER : means a person authorised directly by manufacturer or, in all EC countries, excluding Italy, under his full responsibility, by the distributor of product, to perform any routine and extraordinary maintenance operations, as well as any regulation, control, servicing operations and the replacement of pieces, as may be necessary during the life of the unit.

2.3 Access to the unit

The unit must be placed in an area which can be accessed also by OPERATORS and ENGINEERS; otherwise the unit must be surrounded by a fence at not less than 2 meters from the external surface of the machine.

OPERATORS and ENGINEERS must enter the fenced area only after wearing suitable clothing (safety shoes, gloves, helmet etc.). The INSTALLER personnel or any other visitor must always be accompanied by an OPERATOR.

For no reason shall any unauthorised personnel be left alone in contact with the unit.

2.4 General precautions

The OPERATOR must simply use the controls of the unit; he must not open any panel, other than the one providing access to the control module.

The INSTALLER must simply work on the connections between plant and machine; he must not open any panels of the machine and he must not enable any control.

When you approach or work on the unit, follow the precautions listed below :

- do not wear loose clothing or jewellery or any other accessory that may be caught in moving parts
- wear suitable personal protective equipment (gloves, goggles etc.) when you have to work in the presence of free flames (welding operations) or with compressed air
- if the unit is placed in a closed room, wear ear protection devices
- cut off connecting pipes, drain them in order to balance the pressure to the atmospheric value before disconnecting them,

disassemble connections, filters, joints or other line items

- do not use your hands to check for any pressure drops
- use tools in a good state of repair; be sure to have understood the instructions before using them
- be sure to have removed all tools, electrical cables and any other objects before closing and starting the unit again

2.5 Precautions against residual risks

Prevention of residual risks caused by the control system

- be sure to have perfectly understood the operating instructions before carrying out any operation on the control panel
- when you have to work on the control panel, keep always the operating instructions within reach
- start the unit only after you have checked its perfect connection to the plant
- promptly inform the ENGINEER about any alarm involving the unit
- do not reset manual restoration alarms unless you have identified and removed their cause

Prevention of residual mechanical risks

- install the unit according to the instructions provided in this manual
- carry out all the periodical maintenance operations prescribed by this manual
- wear a protective helmet before accessing the interior of the unit
- before opening any panelling of the machine, make sure that it is secured to it by hinges
- do not touch air condensation coils without wearing protective gloves
- do not remove the guards from moving elements while the unit is running
- check the correct position of the moving elements' guards before restarting the unit

Prevention of residual electrical risks

- connect the unit to the mains according to the instructions provided in this manual
- periodically carry out all the maintenance operations specified by this manual
- disconnect the unit from the mains by the external disconnecting switch before opening the electrical board
- check the proper grounding of the unit before start-up
- check all the electrical connections, the connecting cables, and in particular the insulation; replace worn or damaged cables

2 - Safety (continued)

- periodically check the board's internal wiring
- do not use cables having an inadequate section or flying connections, even for limited periods of time or in an emergency

Prevention of other residual risks

- make sure that the connections to the unit conform to the instructions provided in this manual and on the unit's panelling
- if you have to disassemble a piece, make sure that it has been properly mounted again before restarting the unit
- do not touch the delivery pipes from the compressor, the compressor and any other piping or component inside the machine before wearing protective gloves
- keep a fire extinguisher for electrical appliances near the machine
- on the units installed indoor, connect the safety valve of the refrigeration circuit to a piping network that can channel any overflowing refrigerant outside
- remove and leak of fluid inside and outside the unit
- collect the waste liquids and dry any oil spillage
- periodically clean the compressor compartment, to remove any fouling
- do not store flammable liquids near the unit
- do not disperse the refrigerant and the lubricating oil into the environment
- weld only empty pipes; do not approach flames or other sources of heat to refrigerant pipes
- do not bend/hit pipes containing fluids under pressure

2.6 Precautions during maintenance operations

Maintenance operations can be carried out by authorised technicians only.

Before performing any maintenance operations :

- disconnect the unit from the mains with the external disconnecting switch

- place a warning sign "do not turn on - maintenance in progress" on the external disconnecting switch
- make sure that on-off remote controls are inhibited
- wear suitable personal protective equipment (helmet, safety gloves, goggles and shoes etc.)

To carry out any measurements or checks which require the activation of the machine :

- work with the electrical board open only for the necessary time
- close the electrical board as soon as the measurement or check has been completed
- for outdoor units, do not carry out any operations in the presence of dangerous climatic conditions (rain, snow, mist etc.)

The following precautions must be always adopted :

- do not scatter the fluids of the refrigeration circuit in the surrounding environment
- when replacing an eprom or electronic cards, use always suitable devices (extractor, antistatic bracelet, etc.)
- to replace a compressor, the evaporator, the condensing coils or any other weighty element, make sure that the lifting equipment is consistent with the weight to be lifted
- in air units with independent compressor compartment, do not access the fan compartment unless you have disconnected the machine by the disconnecting switch on the board and you have placed a warning sign "do not turn on - maintenance in progress"
- contact manufacturer for any modifications to the refrigeration, hydraulic or wiring diagram of the unit, as well as to its control logics
- contact manufacturer if it is necessary to perform very difficult disassembly and assembly operations
- use only original spare parts purchased directly from manufacturer or the official retailers of the companies on the recommended spare parts list
- contact manufacturer if it is necessary to handle the unit one year after its positioning on site or if you wish to dismantle it.

2 - Safety (continued)

2.7 Safety labels

Identification of the refrigerant - External door



Identification of the unit Outside, on the right-hand front column

COD. PRODOTTO PRODUCT CODE	(A)
MODELLO MODEL	(B)
CE (C)	
MATRICOLA SERIAL NUMBER	(D)
ANNO DI COSTRUZIONE	(E)
CARICA REFR. x CIRCUIT (1/2/3/4) Kg REFRIGERANT CHARGE	(F) (G) (G) (G) (G)
ALTA PRESSIONE HIGH PRESSURE	(max) bar (H)
BASSA PRESSIONE LOW PRESSURE	(max) bar (I)
ALIM. POTENZA MAIN SUPPLY	V/Ph/Hz (L)
CORRENTE DI SPUNTO ISA	(max) A (M)
CORRENTE A PIENO CARICO ISA	(max) A (N)
POTENZA ASSORBITA POWER INPT	(max) Kw (O)
PRESS. ESERC. ACQUA WATER OPERATING PRESSURE	bar (P)
MASSA MASE	kg (Q)
GRADO IP IP CLASS	(R)
<small>TELCO HOISTERY S.r.l. Via XIV Aprile 29 30050 BARLASSINA NE (PD) - PA MADE IN ITALY COL038800400-000-0</small>	
MODELLO:	
MATRICOLA:	
CODICE:	ANNO DI COSTRUZIONE
MODELLO:	
MATRICOLA:	
CODICE:	ANNO DI COSTRUZIONE
MODELLO:	
MATRICOLA:	
CODICE:	ANNO DI COSTRUZIONE

LAS BOMBAS MONTADAS EN ESTA UNIDAD NO PUEDEN TRABAJAR SIN AGUA.
 DIE PUMPEN DIESES GERÄTES DÜRFEN NICHT OHNE WASSER BETRIEBEN WERDEN.
 THE PUMPS ON BOARD OF THIS UNIT CAN NOT WORK WITHOUT WATER.
 LES POMPE A BORD DE CETTE UNITE NE PEUVENT PAS FONCTIONNER SANS EAU.
 LE POMPE A BORDO DI QUESTA UNITÀ NON POSSONO FUNZIONARE SENZA ACQUA.

Instruction for the lifting

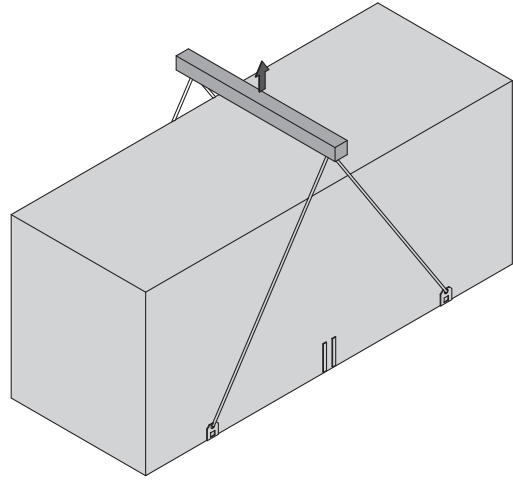

Sequence phase control on the electrical board

ATTENZIONE
 QUESTO COMPRESSORE RICHIEDE UN CORRETTO SENSO DI ROTAZIONE
 RISPETTARE LA CORRETTA SEQUENZA DELLE FASI
CAUTION
 THIS COMPRESSOR REQUIRES PROPER DIRECTION OF ROTATION
 CHECK PROPER ELECTRICAL PHASING
ACHTUNG
 KOMPRESSOREN BENÖTIGEN KORREKTES DREHFELD.
 ELEKTRISCHE ANSCHLÜSSE AUF DREHFELD ÜBERPRÜFEN
ATTENTION
 CES COMPRESSEURS NECESSITENT UN BON SENSE DE ROTATION
 VERIFIER LE CABLAGE DES PHASES
ATENCIÓN
 ESTOS COMPRESORES DEBEN FUNCIONAR EN EL SENTIDO DE ROTACIÓN CORRECTO
 COMPROBAR EL CABLEADO DE LAS FASES

Gravity centre - Base

TENERE SU QUESTA LINEA
 GANCIO DI SOLLEVAMENTO

KEEP LIFT HOOK
 ON THIS LINE

Instruction for the lifting

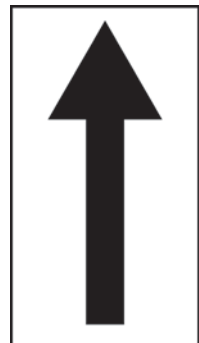

2 - Safety (continued)

Electrical warning Adjacent to the master switch

	ATTENZIONE ! Prima di aprire togliere tensione	ATTENTION ! Enlever l'alimentation électrique avant d'ouvrir
ACHTUNG ! Vor öffnen des gehäuses hauptschalter ausschalten	CAUTION ! Disconnect electrical supply before opening	ATENCIÓN ! Cortar la corriente antes de abrir el aparato

Start-up warning - Outside the door of the electrical board

ATTENZIONE

INSERIRE LE RESISTENZE DI RISCALDAMENTO OLIO ALMENO 12 ORE PRIMA DI OGNI AVVIAMENTO (SE PREVISTE) PRIMA DELLA MESSA IN TENSIONE ASSICURARSI CHE LE VITI DEI CIRCUITI ELETTRICI SIANO SERRATE COMPLETAMENTE

WARNING

ENERGIZE THE CRANCKCASE HEATER FOR AT LEAST 12 HOURS BEFORE EACH STARTING (IF FITTED) BEFORE TIGHTENING-UP, TO TIGHTEN ALL TERMINAL SCREWS ESPECIALLY THOSE IN MAIN CIRCUIT

WARNUNG

OLSUMPFFHEIZUNG (FALLS VORHANDEN) 12 STUNDEN VOR DEM START EINSCHALTEN VOR INBETRIEBNAHME ALLE SCHRAUBENVERBINDUNGEN NACHZIEHEN, BESONDERS DIE ELEKTRISCHEN ANSCHLUSSE

ATTENTION

ALIMENTER ELECTRIQUEMENT LA RESISTANCE DE CARTER AU MOINS 12 HEURES AVANT CHAQUE DEMARRAGE (SI MONTE SUR LE PRODUIT) AVANT DE DEMARRER LA MACHINE, VERIFIER LE SERRAGE DE TOUTES LES BORNES A VIS, SPECIALEMENT DANS LE BOITIER ELECTRIQUE

ATENCIÓN

ATENCIÓN ALIMENTAR ELÉCTRICAMENTE LA RESISTENCIA DE CARTER AL MENOS 12 HORAS ANTES DE CADA PUESTA EN MARCHA (SI ESTA EQUIPADA EN LA UNIDAD) ANTES DE LA PUESTA EN MARCHA, COMPROBAR QUE LOS BORNES ESTAN BIEN APRETADOS, ESPECIALMENTE EN EL CUADRO ELÉCTRICO

035B00057-000

MADE IN ITALY

Final Test Certificate - Inside the external door

CERTIFICATO DI COLLAUDO PRODUZIONE PRODUCTION TEST CERTIFICATE		
PROGR. COLL. CHECK NUMBER	DESCRIZIONE DEI TEST / DESCRIPTION OF QUALITY CHECK	TEMPO OPERAT. INSP. CODE
1	VERIFICA ASSEMBLAGGIO / CHECK ASSEMBLY PARTS	
2	VERIFICA VISIVA CABLAGGIO COLLEG. ELETTRICI E CONNESSIONE / CHECK WIRING CONNECTION	
3	VUOTO E CARICA / VACUUM AND REFRIGERANT CHARGE	
4	VERIFICA CON CERCAFUGHE TENUTA CIRCUITO FRIGORIFERO / REFRIGERANT LEAK TEST	
5	TEST SICUREZZA ELETTRICA / SAFETY TEST	
6	PROVE FUNZIONALI CON RILIEVI TEMPERATURE PRESSIONI RUMORI / FUNCTIONAL AND RUN TEST: NOISE TEST	
7	VERIFICA INTERVENTI SICUREZZE PRESSIONE E TEMPERATURA / CHECK SAFETY DEVICES	
8	VERIFICA VISIVA SONDE / VISUAL CHECK SENSOR	
9	VERIFICA TENUTA CIRCUITO IDR. E FUNZIONAMENTO POMPA (EU PACK) / HYDRAULIC CIRCUIT TEST (PUMP CHECK ONLY FOR PACK UNIT)	
10	VERIFICA MONTAGGIO ACCESSORI (SE PREVISTI) E DOCUMENTAZIONE / CHECK ACCESSORIES DOCUMENTATION	
11	CONTROLLLO ESTETICO FINALE TENUTA CIRCUITO E PULIZIA / VISUAL CHECK/LEAK FINAL TEST AND CLEANING ASPECTS	

Grounding connection on the electrical board, adjacent to the connection

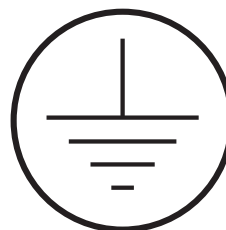

Read the instruction on the electrical board



Fan Danger

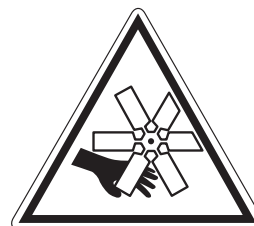

Fitting identification - Adjacent to fittings

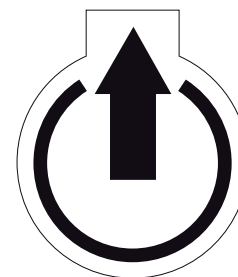
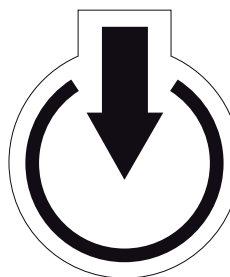

2 - Safety (continued)

2.8 Safety regulations

REFRIGERANT DATA	SAFETY DATA : R410A
Toxicity	Low
Contact with skin	<p>If sprayed, the refrigerant is likely to cause frost burns. If absorbed by the skin, the danger is very limited; it may cause a slight irritation, and the liquid is degreasing. Unfreeze the affected skin with water. Remove the contaminated clothes with great care - in the presence of frost burns, the clothes may stick to the skin. Wash with plenty of warm water the affected skin.</p> <p>In the presence of symptoms such as irritation or blisters, obtain medical attention.</p>
Contact with eyes	<p>Vapours do not cause harmful effects. The spraying of refrigerant may cause frost burns. Wash immediately with a proper solution or with tap water for at least 10 minutes, and then obtain medical attention.</p>
Ingestion	<p>Very unlikely - should something happen, it will cause frost burns.</p> <p>Do not induce vomiting. Only if the patient is conscious, wash out mouth with water and give some 250 ml of water to drink. Then, obtain medical attention.</p>
Inhalation	<p>R410A : remarkable concentrations in the air may have an anaesthetic effect, up to fainting.</p> <p>The exposure to considerable amounts may cause irregular heartbeat, up to the sudden death of the patient. Very high concentrations may result in the risk of asphyxia, due to the reduction in the oxygen percentage in the atmosphere. Remove the patient to fresh air and keep warm and at rest.</p> <p>If necessary, give oxygen. In case of breathing difficulties or arrest, proceed with artificial respiration.</p> <p>In case of cardiac arrest, proceed with cardiac massage. Then, obtain medical attention.</p>
Recommendations	<p>Semiotics or support therapy is recommended. Cardiac sensitisation has been observed that, in the presence of circulating catecholamines such as adrenalin, may cause cardiac arrhythmia and accordingly, in case of exposure to high concentrations, cardiac arrest.</p>
Prolonged exposure	<p>R410A : a study on the effects of exposure to 50,000 ppm during the whole life of rats has identified the development of benign testicle tumour.</p> <p>This situation should therefore be negligible for personnel exposed to concentrations equal to or lower than professional levels.</p>
Professional levels	R410A : Recommended threshold : 1000 ppm v/v - 8 hours TWA.
Stability	R410A : Not specified
Conditions to avoid	Do not use in the presence of flames, burning surfaces and excess humidity.
Hazardous reactions	<p>May react with sodium, potassium, barium and other alkaline metals.</p> <p>Incompatible substances: magnesium and alloys with magnesium concentrations > 2%.</p>
Hazardous decomposition products	R410A : Halogen acids produced by thermal decomposition and hydrolysis.

2 - Safety (continued)

2.8 Safety regulations (continued)

REFRIGERANT DATA	SAFETY DATA : R410A
General precautions	Do not inhale concentrated vapours. Their concentration in the atmosphere should not exceed the minimum preset values and should be maintained below the professional threshold. Being more weighty than the air, the vapour concentrates on the bottom, in narrow areas. Therefore, the exhaust system must work at low level.
Respiratory system protection	If you are in doubt about the concentration in the atmosphere, it is recommended to wear a respirator approved by an accident-prevention Authority, of the independent or oxygen type.
Storage	Cylinders must be stored in a dry and fresh place, free from any fire hazard, far from direct sunlight or other sources of heat, radiators etc. Keep a temperature below 50 °C.
Protective clothing	Wear overalls, protective gloves and goggles or a mask.
Accidental release measures	It is important to wear protective clothing and a respirator. Stop the source of the leak, if you can do this without danger. Negligible leaks can be left evaporating under the sun, providing that the room is well ventilated. Considerable leaks : ventilate the room. Reduce the leak with sand, earth or other absorbing substances. Make sure that the liquid does is not channelled into gutters, sewers or pits where the vapours are likely to create a stuffy atmosphere.
Disposal	The best method is recovery and recycling. If this method is not practicable, dispose according to an approved procedure, that shall ensure the absorption and neutralization of acids and toxic agents.
Fire fighting information	R410A : Not flammable in the atmosphere.
Cylinders	The cylinders, if exposed to fire, shall be cooled by water jets; otherwise, if heated, they may explode.
Protective fire fighting equipment	In case of fire, wear an independent respirator and protective clothing.

2 - Safety (continued)

2.8 Safety regulations (continued)

LUBRICANT OIL DATA	SAFETY DATA : POLYESTER OIL (POE)
Classification	Not harmful.
Contact with skin	May cause slight irritation. Does not require first aid measures. It is recommended to follow usual personal hygiene measures, including washing the exposed skin with soap and water several times a day. It is also recommended to wash your overalls at least once a week.
Contact with eyes	Wash thoroughly with a suitable solution or tap water.
Ingestion	Seek medical advice immediately.
Inhalation	Seek medical advice immediately.
Conditions to avoid	Strong oxidising substances, caustic or acid solutions, excess heat. May corrode some types of paint or rubber.
Protection of the respiratory system	Use in well ventilated rooms.
Protective clothing	Always wear protective goggles or a mask. Wearing protective gloves is not mandatory, but is recommended in case of prolonged exposure to refrigerant oil.
Accidental release measures	It is important to wear protective clothing and, especially, goggles. Stop the source of the leak. Reduce the leak with absorbing substances (sand, sawdust or any other absorbing material available on the market).
Disposal	The refrigerant oil and its waste will be disposed of in an approved incinerator, in conformity with the provisions and the local regulations applicable to oil waste.
Fire fighting information	In the presence of hot liquid or flames, use dry powder, carbon dioxide or foam. If the leak is not burning, use a water jet to remove any vapours and to protect the personnel responsible for stopping the leak.
Cylinders	The cylinders exposed to a fire will be cooled with water jets in case of fire.
Fire fighting protective equipment	In case of fire, wear an independent respirator.

3 - Transport, Lifting and Positioning

Refrigerators are supplied assembled (apart from standard antivibrating rubber supports, that will be installed on site). The equipment are full of refrigerant and oil, in the quantity required for a proper operation.

3.1 Inspection

When the unit is delivered, it is recommended to check it carefully and to identify any damage occurred during transportation. The goods are shipped ex-factory, at the buyer's risk. Check that the delivery includes all the components listed in the order.

In case of damage, note it down on the carrier's delivery note and issue a claim according to the instructions provided in the delivery note.

In the presence of any serious damage, that does not affect the surface only, it is recommended to inform manufacturer immediately.

Please note that manufacturer may not be held liable for any damage to the equipment during transportation, even though the carrier has been appointed by the factory.

3.2 Lifting

The unit must be lifted by using the hooks inserted into the relevant eyebolts (see the figure).

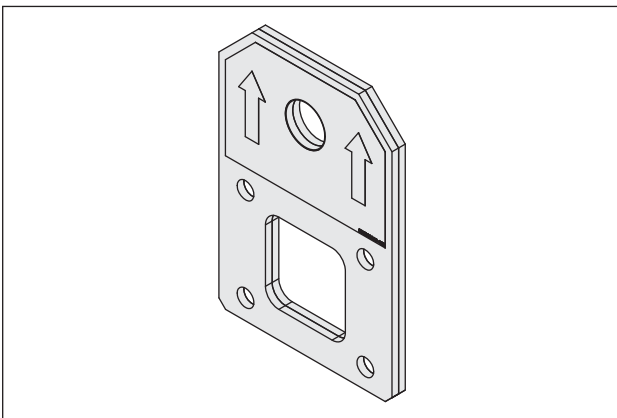

It is recommended to use a spacer to prevent cables from damaging the unit (see the figure).

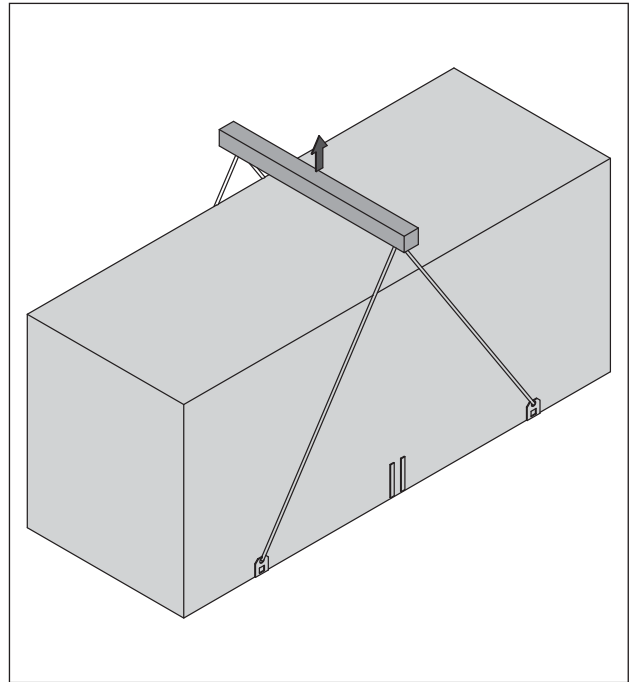

Before positioning the unit, make sure that the place of installation is appropriate and sturdy enough to hold the weight and to withstand the stress caused by the operation of the whole assembly.



Do not displace the unit on rollers, and do not lift it with a lift truck.

Unit must be lifted carefully.

To lift unit slowly and regularly.

To lift and displace the unit :

- Insert and secure eyebolts into the holes marked on the frame.
- Insert spacer between cables.
- Hook near the barycentre of the unit.
- The cables must be long enough to form, if tensioned, an angle of at least 45° with respect to the horizontal plane.



For lifting operations, use only tools and material fit for this purpose, in accordance with accident-prevention regulations.

3 - Transport, Lifting and Positioning (continued)



During the lifting and handling of the unit, be careful not to damage the finned pack of the coils positioned on the sides of the unit.

The sides of the unit must be protected by cardboard or plywood sheets.



It is recommended not to remove the protective plastic envelope, that should prevent scraps from penetrating into the appliance and any damage to the surfaces, until the unit is ready for operation.



The lifting eyebolts protrude from the base of the unit; it is therefore recommended to remove them once the unit has been lifted and positioned, if in your opinion they are likely to become a source of hazard and injury.

The eyebolts must be mounted on the unit whenever it shall be displaced and then lifted again.

3.3 Anchoring

It is not essential to secure the unit to the foundations, unless in areas where there is a serious risk of earthquake, or if the appliance is installed on the top of a steel frame.

3.4 Storage

When the unit is to be stored before installation, adopt a few precautions to prevent any damage or risk of corrosion or wear:

- plug or seal every single opening, such as water fittings
- do not store the appliance in a room where the temperature exceeds 50 °C for the units using R410A and, if possible, do not expose to direct sunlight
- minimum storage temperature is -25 °C
- it is recommended to store the unit in a roof where traffic is minimized, to prevent the risk of accidental damage
- the unit must not be washed with a steam jet
- take away and leave to the site manager all the keys providing access to the control board

Finally, it is recommended to carry out visual inspections at regular intervals.

4 - Installation

4.1 Positioning of the unit



Before installing the unit, make sure that the structure of the building and/or the supporting surface can withstand the weight of the appliance. The weights of the units are listed in Chapter 8 of this manual.

These units have been designed for outdoor installation on a solid surface. Standard accessories include antivibrating rubber supports, that must be positioned under the base.

When the unit is to be installed on the ground, it is necessary to provide a concrete base, to ensure a uniform distribution of the weights.

As a general rule, no special sub-bases are required. However, if the unit is to be installed on the top of inhabited rooms, it is advisable to rest it on spring shock absorbers (optional), that will minimise the transmission of any vibration to the structures.

To choose the place of installation of the unit, bear in mind that :

- the longitudinal axis of the unit must be parallel to the direction of prevailing winds, so as to ensure a uniform distribution of the air on finned exchangers
- the unit must not be installed near boilers' vent pipes
- the unit must not be installed leeward with respect to sources of air contaminated by greases, such as, for example, the outlets to kitchen exhaust hoods into the atmosphere. Otherwise, the grease is likely to deposit on the fins of the refrigerant /air exchangers, and would fix every type of atmospheric impurity, resulting in the quick clogging of the exchangers
- the unit must not be installed in areas subject to considerable snow falling
- the unit must not be installed in areas subject to flooding, under gutters etc.
- the unit must not be installed in air shafts, narrow courts or other small places, where the noise may be reflected by the walls or the air ejected by fans may short-circuit itself on refrigerant/air heat exchangers or condenser
- the place of installation must be have all the necessary spaces for air circulation and maintenance operations (see Chapter 8).

4.2 Spring Isolator Installation

- Prepare the base, that must be flat and plane.
- Lift the appliance and insert shock absorbers as follows:

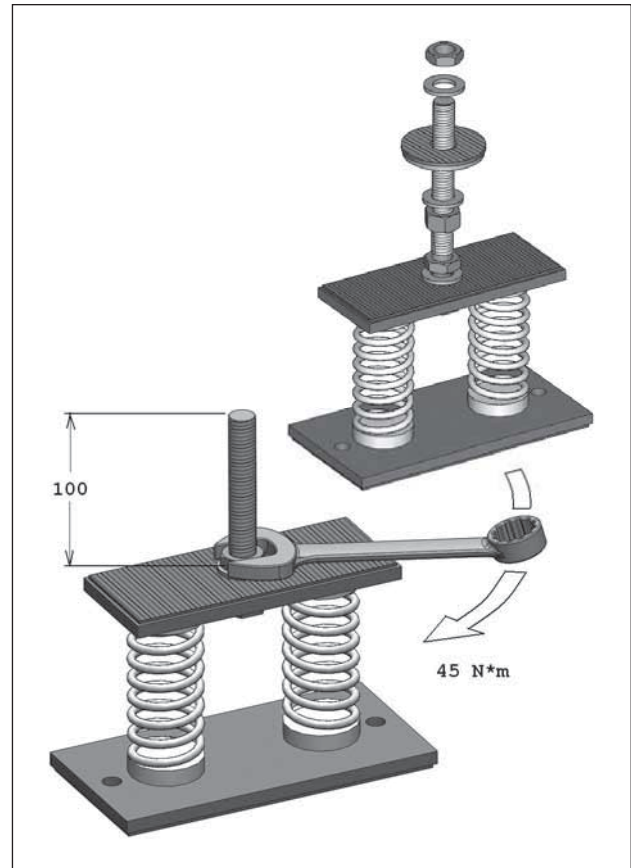

- 1) Proceed to assemble the jack components. Fit the jack in the threaded housing on the upper plate of the antivibration mount.

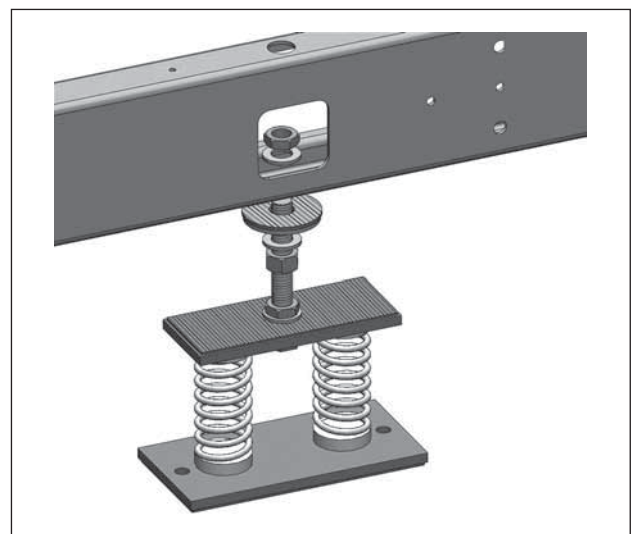

- 2) Fit the jack mounted on the antivibration mount in the hole in the machine base.

4 - Installation (continued)

4.3 External Water Circuit



The external water circuit shall guarantee a constant water flow rate through the circulating refrigerant/water heat exchanger (evaporator) under steady operating conditions and in case of a load variation.

The circuit shall be composed by the following elements :

- A circulation pump which can ensure the necessary flow rate and head.
- The total content of the primary water circuit shall never be lower than 5 l/kW in terms of refrigerating capacity. If the total water volume in the primary circuit should be unable to reach such a value, an additional heat-insulated storage tank should be installed. This tank is intended to avoid any repetitive start of the compressor.
- A membrane expansion tank complete with a safety valve and a drain which shall be visible.



The expansion tank shall be dimensioned in such a way that it can absorb a 2% expansion of the total volume of the water in the plant (exchanger, pipelines, uses and storage tank, if available).

The expansion tank shall never be insulated when the circulating fluid is not flowing through it.

A water flow switch is mounted as a standard. It will stop the unit whenever a flow rate problem occurs.

In addition :

- Install on/off valves (accessory) on the lines at the inlet and outlet of the manifolds of the exchangers (evaporator).
- Arrange a by-pass complete with an on/off valve between the manifolds of the heat exchangers.
- Arrange air vent valves at the high points of the water lines.
- Arrange drain points complete with plugs, clocks, etc. in the proximity of the low points of the water lines.
- Insulate the water lines to prevent the heat from blowing back into the unit.

4 - Installation (continued)

Hydraulic Circuit Diagram - AQVSL/AQVSH STAR 85 to 160 - R410A - Basic Unit

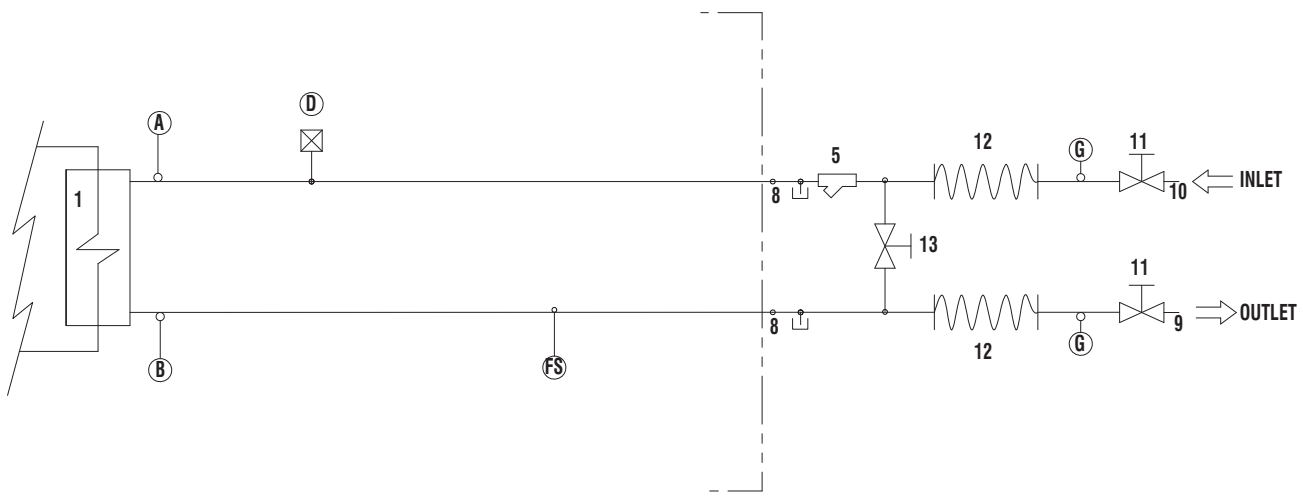

COMPONENTS	
1	Plate heat exchanger
5	Water filter
8	Pressure point/Drainage
9	Water outlet
10	Water inlet
11	Globe valve
12	Flexible pipes
13	By-pass valve

SAFETY/CONTROL DEVICES	
A	Inlet water temperature sensor
B	Outlet water temperature sensor
D	Vent valve
FS	Flow switch
G	Thermometer
----	Unit side
○	Probes

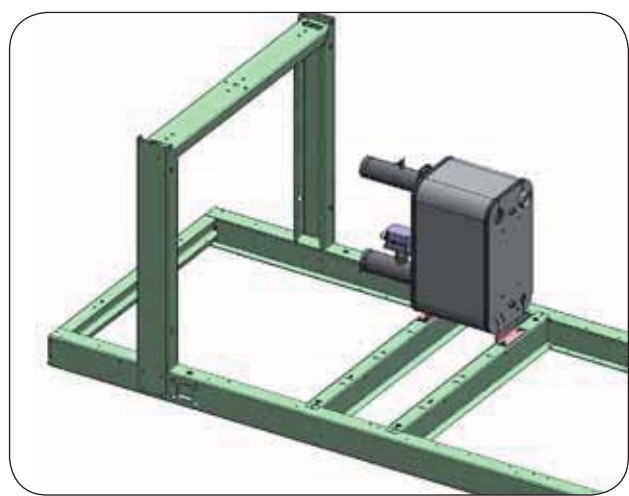

4 - Installation (continued)

Hydraulic Circuit Diagram - AQVSL/AQVSH STAR 85 to 160 - R410A - 1P Unit

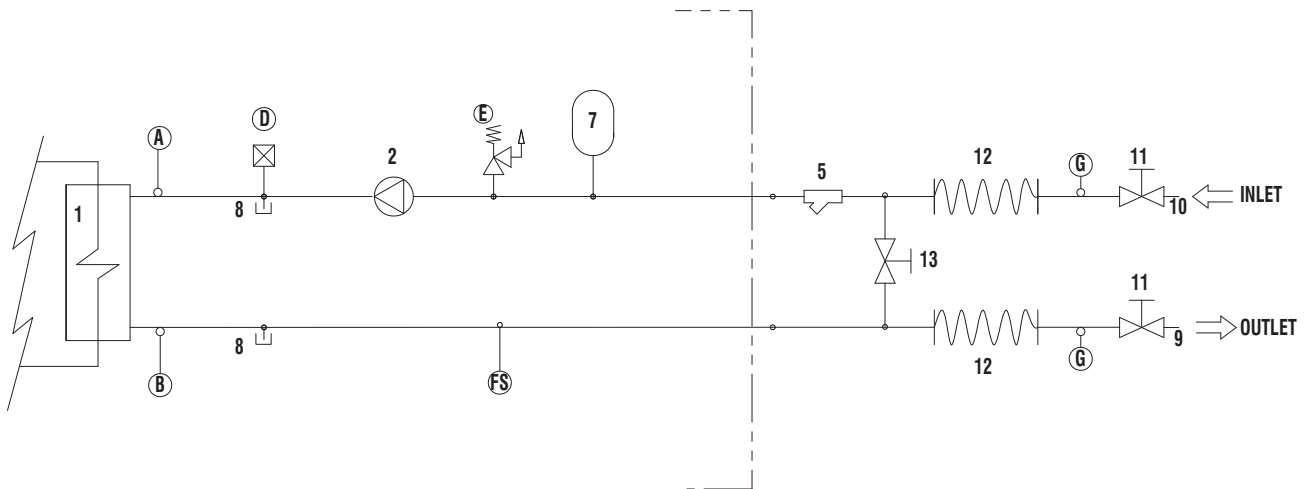

COMPONENTS	
1	Plate heat exchanger
2	Pump
5	Water filter
7	Pressure expansion tank
8	Pressure point/Drainage
9	Water outlet
10	Water inlet
11	Globe valve
12	Flexible pipes
13	By-pass valve

SAFETY/CONTROL DEVICES	
A	Inlet water temperature sensor
B	Outlet water temperature sensor
D	Vent valve
E	Water safety valve (6 bar)
FS	Flow switch
G	Thermometer
----	Unit side
○	Probes

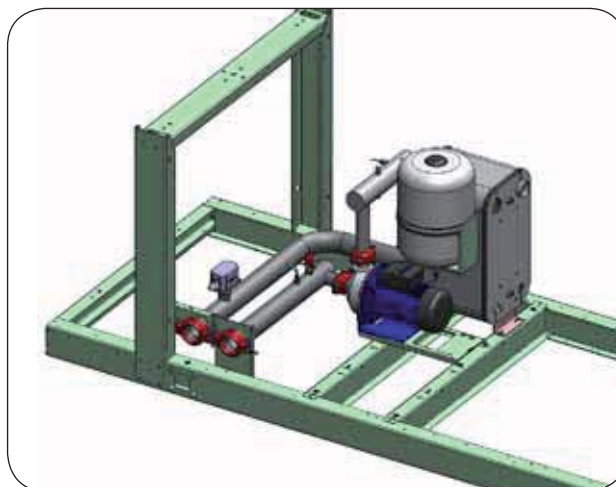

4 - Installation (continued)

Hydraulic Circuit Diagram - AQVSL/AQVSH STAR 85 to 160 - R410A - 2P Unit

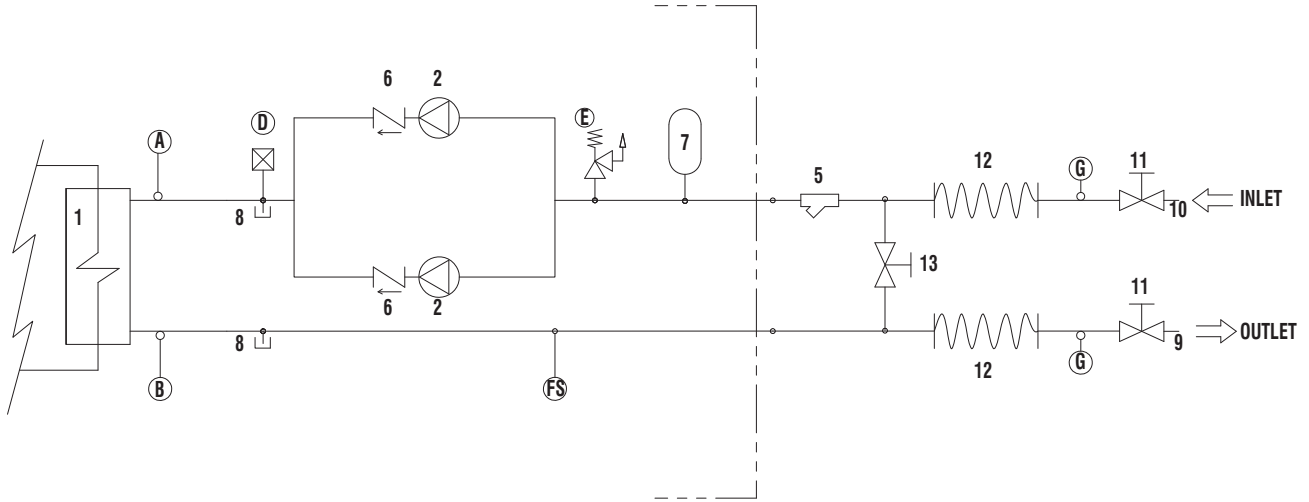

COMPONENTS	
1	Plate heat exchanger
2	Pump
5	Water filter
6	Non-return valve
7	Pressure expansion tank
8	Pressure point/Drainage
9	Water outlet
10	Water inlet
11	Globe valve
12	Flexible pipes
13	By-pass valve

SAFETY/CONTROL DEVICES	
A	Inlet water temperature sensor
B	Outlet water temperature sensor
D	Vent valve
E	Water safety valve (6 bar)
FS	Flow switch
G	Thermometer
----	Unit side
○	Probes

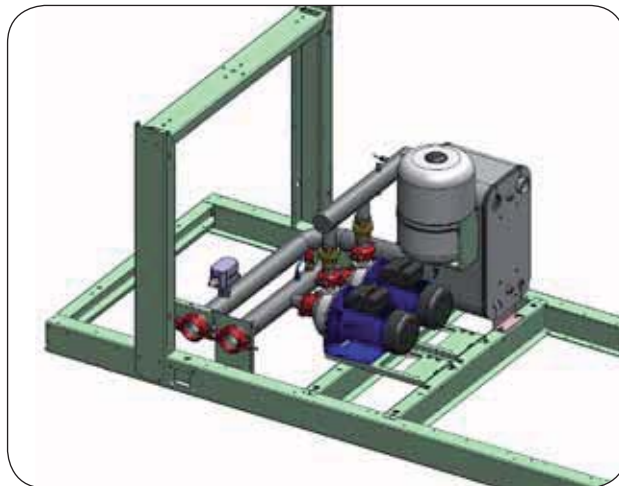

4 - Installation (continued)

Hydraulic Circuit Diagram - AQVSL/AQVSH STAR 85 to 160 - R410A - 3P Unit

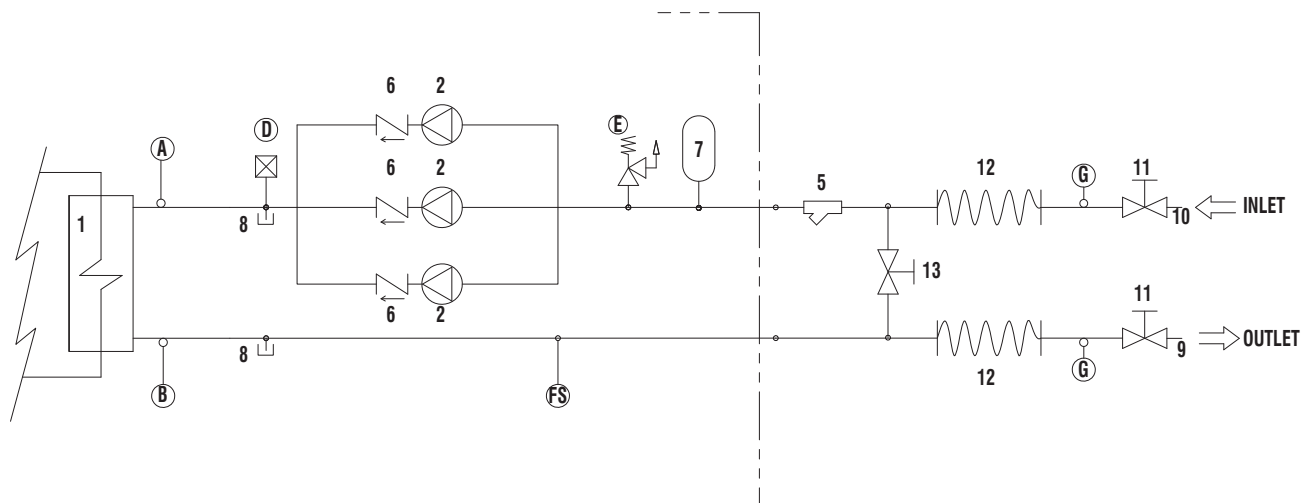

COMPONENTS	
1	Plate heat exchanger
2	Pump
5	Water filter
6	Non-return valve
7	Pressure expansion tank
8	Pressure point/Drainage
9	Water outlet
10	Water inlet
11	Globe valve
12	Flexible pipes
13	By-pass valve

SAFETY/CONTROL DEVICES	
A	Inlet water temperature sensor
B	Outlet water temperature sensor
D	Vent valve
E	Water safety valve (6 bar)
FS	Flow switch
G	Thermometer
----	Unit side
○	Probes

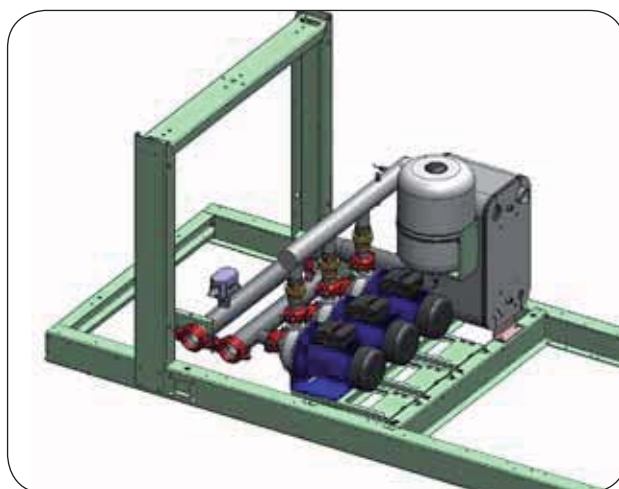

4 - Installation (continued)

Hydraulic Circuit Diagram - AQVSL/AQVSH STAR 85 to 160 - R410A - 1P+T Unit

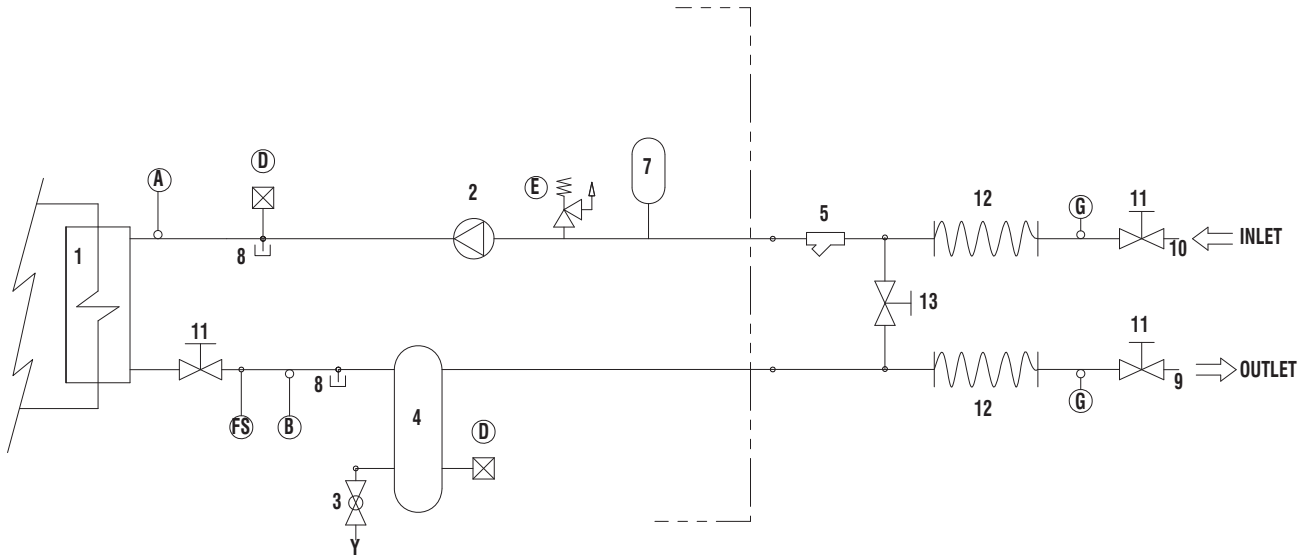

COMPONENTS	
1	Plate heat exchanger
2	Pump
3	Draining valve
4	Water buffer tank
5	Water filter
7	Pressure expansion tank
8	Pressure point/Drainage
9	Water outlet
10	Water inlet
11	Globe valve
12	Flexible pipes
13	By-pass valve

SAFETY/CONTROL DEVICES	
A	Inlet water temperature sensor
B	Outlet water temperature sensor
D	Vent valve
E	Water safety valve (6 bar)
FS	Flow switch
G	Thermometer
----	Unit side
○	Probes

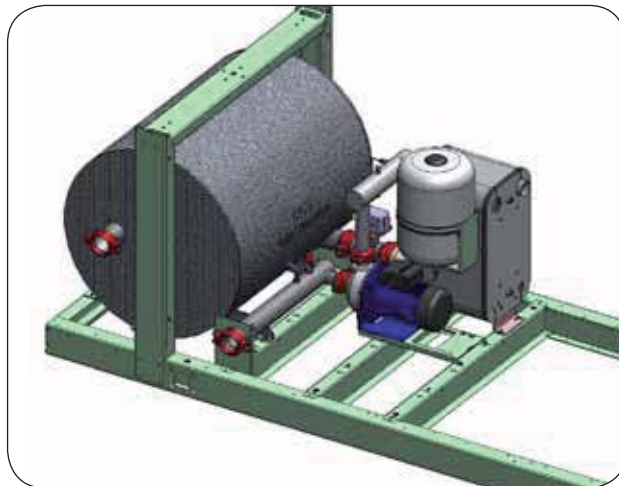

4 - Installation (continued)

Hydraulic Circuit Diagram - AQVSL/AQVSH STAR 85 to 160 - R410A - 2P+T Unit

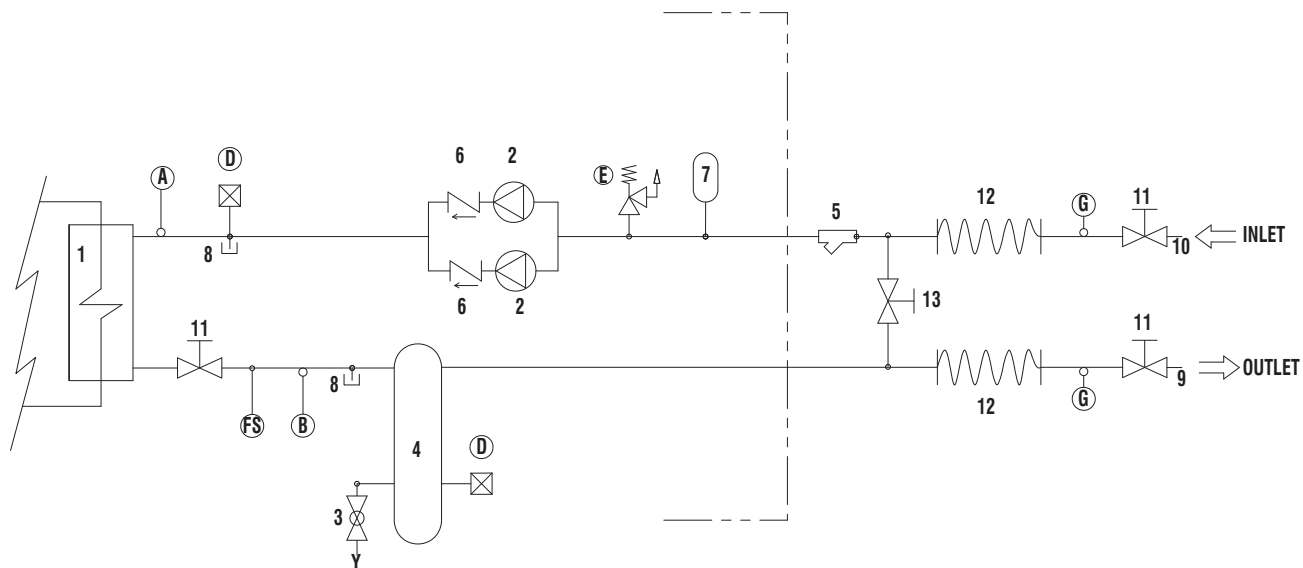

COMPONENTS	
1	Plate heat exchanger
2	Pump
3	Draining valve
4	Water buffer tank
5	Water filter
6	Non-return valve
7	Pressure expansion tank
8	Pressure point/Drainage
9	Water outlet
10	Water inlet
11	Globe valve
12	Flexible pipes
13	By-pass valve

SAFETY/CONTROL DEVICES	
A	Inlet water temperature sensor
B	Outlet water temperature sensor
D	Vent valve
E	Water safety valve (6 bar)
FS	Flow switch
G	Thermometer
----	Unit side
○	Probes

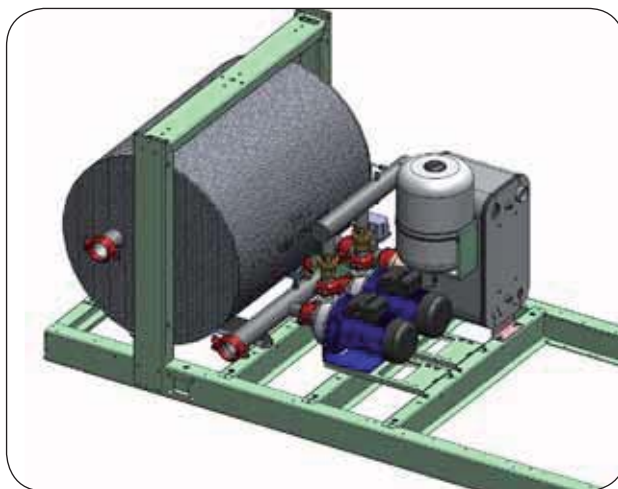

4 - Installation (continued)

Hydraulic Circuit Diagram - AQVSL/AQVSH STAR 85 to 160 - R410A - 3P+T Unit

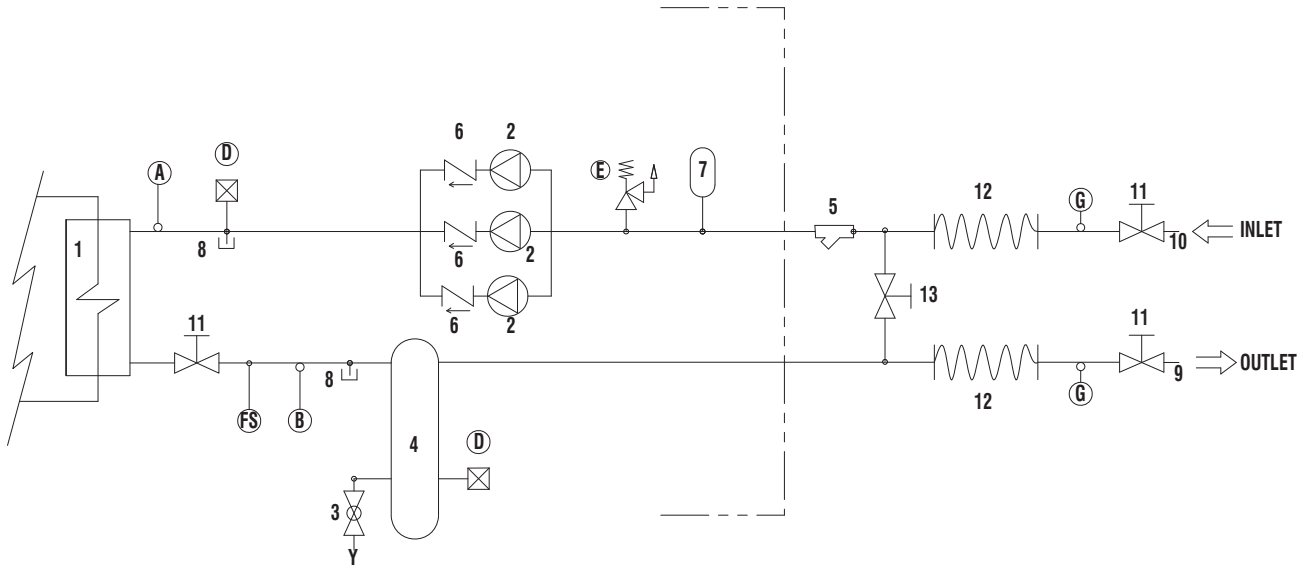

COMPONENTS	
1	Plate heat exchanger
2	Pump
3	Draining valve
4	Water buffer tank
5	Water filter
6	Non-return valve
7	Pressure expansion tank
8	Pressure point/Drainage
9	Water outlet
10	Water inlet
11	Globe valve
12	Flexible pipes
13	By-pass valve

SAFETY/CONTROL DEVICES	
A	Inlet water temperature sensor
B	Outlet water temperature sensor
D	Vent valve
E	Water safety valve (6 bar)
FS	Flow switch
G	Thermometer
----	Unit side
○	Probes

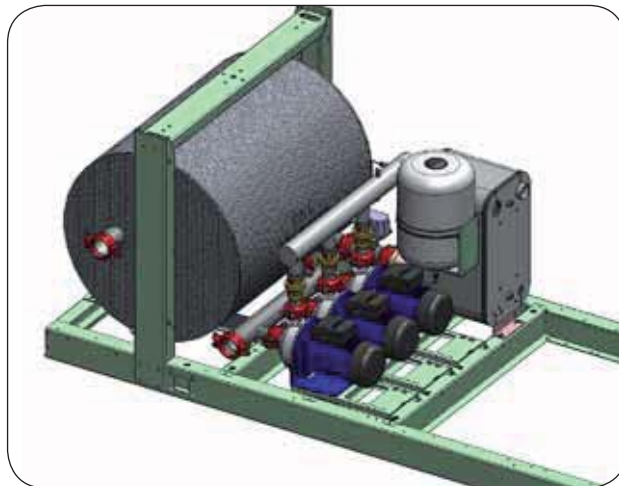

4 - Installation (continued)

4.4 Water connections



The attachments at the water inlet and outlet shall be connected in compliance with the instructions which can be found on the labels in the proximity of the attachments.

Connect the water lines of the plants with the attachments of the unit whose diameters and positions are shown by Chapter 8.

4.5 Defrost water drainage (only for AQVSH units)

When heat pump units work in heating mode, during defrosting cycles, they may discharge water from the base. This is why the units should be installed at least 200 mm above the floor level, so as to allow the free drainage of waste water, without the risk of producing ice banks.

The heat pump units must be installed in positions where the defrosting water cannot create any damage.

4.6 Power supply



Before carrying out any operations on the electrical system, make sure that the unit is deenergised.



It is important that the appliance is grounded.



The company in charge of the installation shall conform to the standards applicable to outdoor electrical connections.

The manufacturer may not be held liable for any damage and/or injury caused by failure to comply with these precautions.

The unit conforms to EN 60204-1.

The following connections shall be provided :

- A 3-phase and grounding connection for the power supply circuit.
- The electrical distribution system shall meet the power absorbed by the appliance.
- The disconnecting and magnetothermal switches must be sized to control the starting current of the unit.
- The power supply lines and the insulation devices must be designed in such a way that every line independent.
- It is recommended to install differential switches, to prevent any damage caused by phase drops.
- The fans and compressors are supplied through contactors controlled from the control panel.
- Each motor is provided with an internal safety thermal device and external fuses.
- The power supply cables must be inserted into dedicated openings on the front of the unit, and they will enter the electrical board through holes drilled on the bottom of the board.

4 - Installation (continued)

4.7 Electrical connections

The unit must be installed on site according to the Machinery Directive (2006/42/EC), the Low Voltage Directive (2006/95/EC), the Electromagnetic Interference Directive (2004/108/EC) and the usual procedures and standards applicable in the place of installation.

The unit must not be operated if its installation has not been carried out according to the instructions provided in this manual.

The power supply lines must consist of insulated copper conductors, dimensioned for the maximum absorbed current.

Connection to terminals must be performed according to the diagram of connections (User's Terminal Box) provided in this manual and according to the wiring diagram which accompanies the unit.



Before connecting the power supply lines, check that the available voltage value does not exceed the range specified in the Electric Data (Chapter 8).

For 3-phase systems, check also that the unbalance between the phases does not exceed 2%. To perform this check, measure the differences between the voltage of each phase couple and their mean

value during operation.

The maximum % value of these differences (unbalance) must not exceed 2% of the mean voltage.

If the unbalance is unacceptable, contact the Energy Distributor to solve this problem.



Supplying the unit through a line whose unbalance exceeds the permissible value will automatically void the warranty.

4.8 Connecting plate-type evaporator temperature sensors

AQVSL and AQVSH units are provided with fittings for hydraulic connections between heat exchangers and plant.

Each fittings is complete with sensor well to fasten temperature sensor (BT-IN and BT-OUT). Fittings are supplied separate and must be mounted during the installation of the unit, as explained in the instruction below.

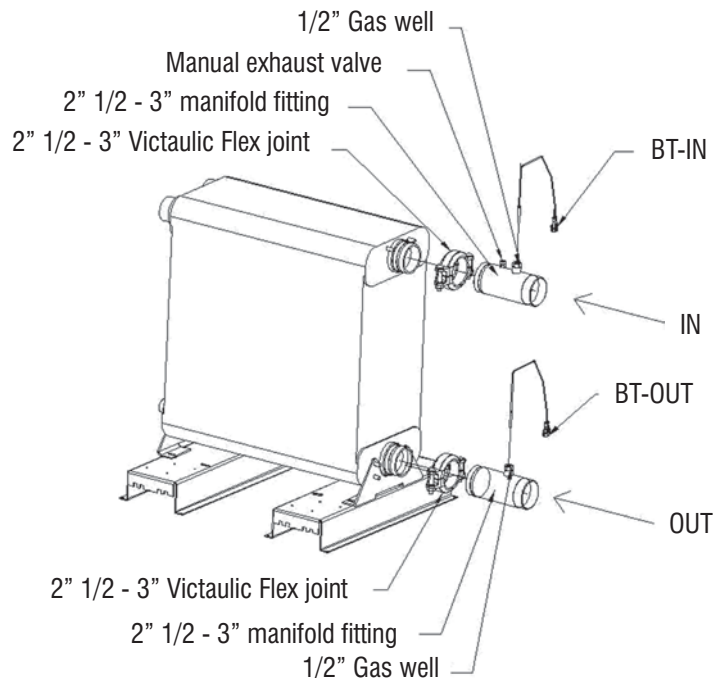

4 - Installation (continued)

AQVSL/AQVSH STAR - Electrical Connections

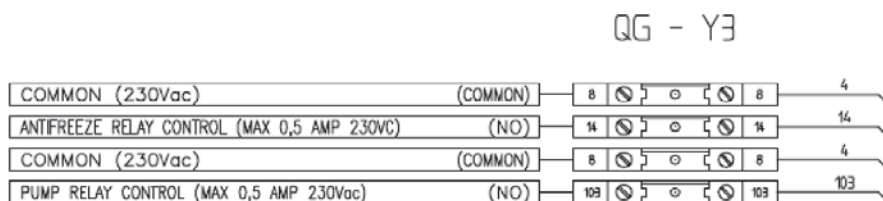
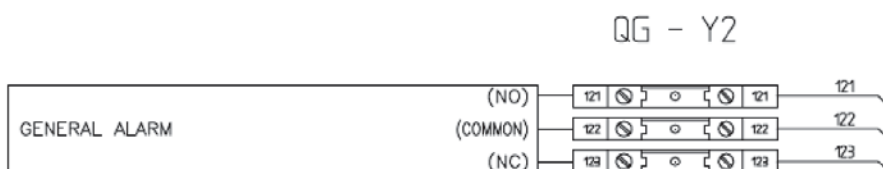
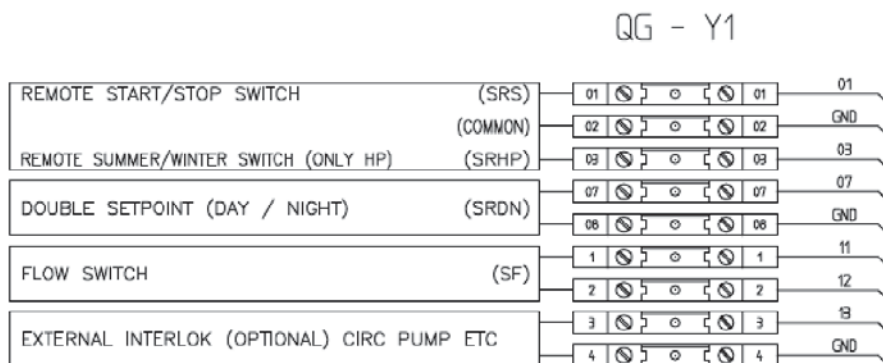

MORSETTIERA UTENTE / USER TERMINALS

4 - Installation (continued)

4.9 Microchannel type condenser coils

On cooling only unit fitted with microchannel type condensers, it is necessary to remove the fixation screws, once unit is installed, as shown in figure below.

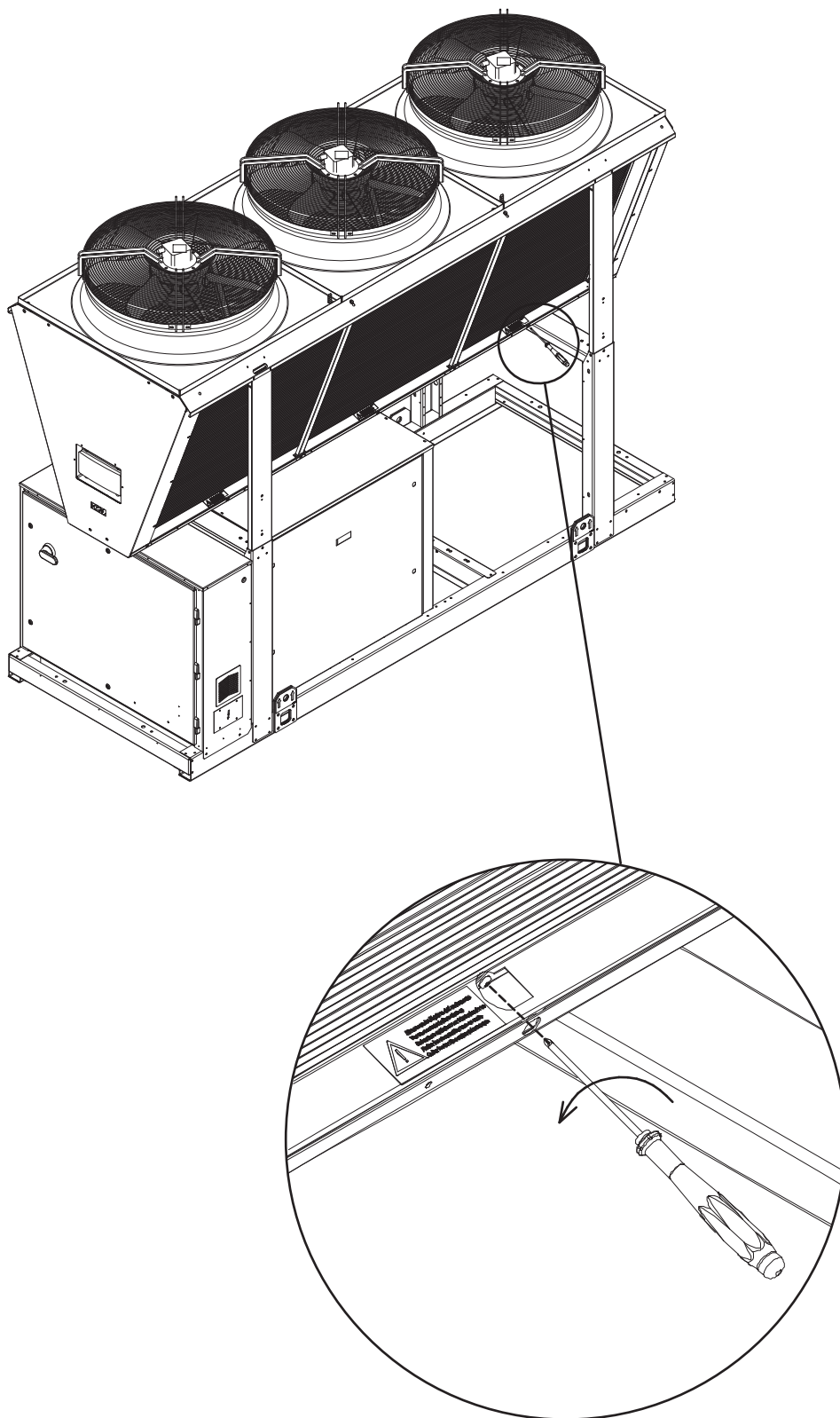

5 - Start-Up



The unit must be started for the first time by personnel suitably trained by one Authorised Service Centre. Failure to meet this requirement will immediately void the warranty.



The operations carried out by authorised personnel are limited to the start-up of the unit, and do not include any other operation on the plant, such as, for example, electrical and hydraulic connections etc.

All the other operations before start-up, including oil pre-heating for at least 12 hours, must be performed by the Installer.

5.1 Preliminary check

The checks listed below shall be performed before starting the unit and before the arrival of the personnel authorised.

- Check the section of power supply and grounding cables; make sure that terminals are tightened and check the correct operation of contactors, with the main switch open.
- Check that any voltage and phase variation in the power supply does not exceed the prefixed thresholds.
- Connect the contacts of the flow switch and the thermal relay of the pump and of the other devices (if any), to terminals 1-2 and 3-4, respectively.
- Check that the components of the external water circuit (pump, user equipment, filters, power supply tank and reservoir, if any) have been installed properly, and according to the manufacturer's instructions.
- Check the filling of the hydraulic circuits, and make sure that the fluid circulation is correct, without any trace of leaks and air bubbles. If you use ethylene glycol as antifreeze, check that its percentage is correct (do not exceed 35% glycol percentage).
- Check that the direction of rotation of the pumps is correct, and that fluids have been circulating for at least 12 hours for both pumps. Then, clean the filters on the suction side of the pumps.
- Adjust the liquid distribution network in such a way that the flow rate is within the specified range.
- Check that the water quality is up to the specifications.
- Check that oil heaters, if any, have been turned on at least 12 hours before.

5.2 Start-up

Start-up sequence :

- Turn on the Main switch (at least 12 hours before).
- Check that the oil in the compressor has reached the requested temperature (the minimum temperature outside the pan must be approx. 40°C) and that the auxiliary control circuit is energised.
- Check the operation of all the external equipment, and make sure that the control devices of the plant are properly calibrated.

- Start the pump and check that the water flow is correct.
- Set the desired fluid temperature on the control board.
- Start the appliance (see Chapter 6).
- Check the correct direction of rotation of compressors. Scroll compressors cannot compress the refrigerant when they rotate in the opposite direction. To make sure that they are rotating in the correct direction, simply check that, just after the start-up of the compressor, the pressure drops on the LP side and rises on the HP side. Furthermore, if a scroll compressor rotate in the opposite direction, there is a considerable rise in the sound level of the unit, as well as in a dramatic reduction of current absorption compared to normal values. In case of wrong rotation, the scroll compressor can be definitely damaged. Phase monitor is assembled in the unit as a standard to prevent wrong compressors rotation.
- After about 15 minutes of operation check that there are no bubbles, through the sight glass on the liquid line.



The presence of bubbles may indicate that a part of the refrigerant charge has been released in one or more points. It is important to remove these leaks before proceeding.

- Repeat the start-up procedure after removing the leaks.

5.3 Checking the operation

Check the following :

- The temperature of the water entering the evaporator.
- The temperature of the water leaving the evaporator.
- The level of the water flow rate in the evaporator, if possible.
- The current absorption upon the start of the compressor and in case of stabilised operation.
- The fan's current absorption.

Check that the condensing and evaporation temperatures, during operation at high and low pressure detected by the pressure gauges of the refrigerant, are within the following range:

(On the units not provided with HP/LP pressure gauges for the refrigerant, connect a pressure gauge to the Schrader valves on the refrigeration circuit).

HP side	Approx. 15 to 21 °C above the temperature of the air entering the condenser, for R410A units.
LP side	Approx. 2 to 4 °C below the temperature of the leaving chilled water, for R410A units.

5.4 Delivery to the customer

- Train the user according to the instructions provided in Section 6.

6 - Control

6 General information

Introduction

This document contains the information and the operating instructions for AQVSL/AQVSH STAR 2 compressors & electronic control.

This information is for the after-sales service and the production operators, for the end-of-line testing.

Main characteristics

- microprocessor control
 - user-friendly keyboard
 - proportional and integral control of the return water temperature (RWT)
 - hysteresis control of the leaving water temperature (LWT)
 - access code to enter the Manufacturer's Level
 - access code to enter the Assistance Level
 - alarm and LED
 - backlighted LCD
 - pump-down logic (start-stop)
 - rotation of the compressor operation
 - oil return function
 - night mode (or Low Noise) control
 - counting of the pump/compressors' hours of operation
 - display of discharge and suction pressure values
 - display of temperature sensor
 - history of stored alarms (option)
 - programming of different setpoints with 4 ranges of time/setpoint.
- The following accessories can be also connected :
- Real Time Clock Memory Card: alarm history and programming of different setpoints with ranges of time
 - serial communication RS485 card; to connect the "Chiller Control" to a BMS network
 - remote display terminal
 - wire remote control.

6.1 Control of AQVSL/AQVSH STAR with 2 compressors - The "CHILLER CONTROL" system

AQVSL/AQVSH STAR are provided with a microprocessor card which is fully programmed by default for the control of a cooling only/heat pump units with 1 circuit and 2 compressors.

The control system consists of :

Keyboard & Display Terminal

General information

The figure shows the terminal with the front door open.

It is provided with a LCD 4 lines x 20 columns, keyboard and microprocessor-controlled LED's, so as to

allow the programming of the control parameters (setpoint, differential bands, alarm thresholds) and themain operations to be carried out by the user.

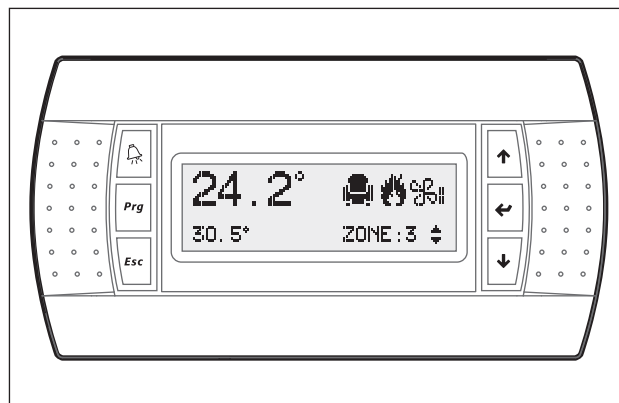

Terminal & Key Board description







The terminal makes it possible to carry out the following operations:

- the initial configuration of the machine
- the change of all the main operating parameters
- the display of the detected alarms
- the display of all the measured quantities

The terminal and the card are connected by a 6-way phone cable.

The connection of the terminal to the basic card is not essential for the normal operation of the controller.

6 - Control (continued)

	Access to the "display mask" of the machine status.
	<pre> +-----+ User Manufactured Maintenance In/Out +-----+ +-----+ Setpoint Release On/Off Daily time zone +-----+ </pre>
	Esc key : allows you to move from one mask to another.
	Alarm key : used to display the alarms, to reset them in manual. Press it one to display the mask of the activated alarm, press it again to reset the alarm signal.
	Prg + Esc keys : pressing these keys at the same time, allows you to turn the unit On/Off.
	Up-down keys : allows you to set the control parameters' values and to move from one mask to another (not backlighted).
	Enter key : used to move the cursor inside the masks and to save the values of the set parameters.
	Alarm + Enter keys : press these keys at the same time to enter the "historical alarm" after 1' come back at status machine menu.

6.2 Display

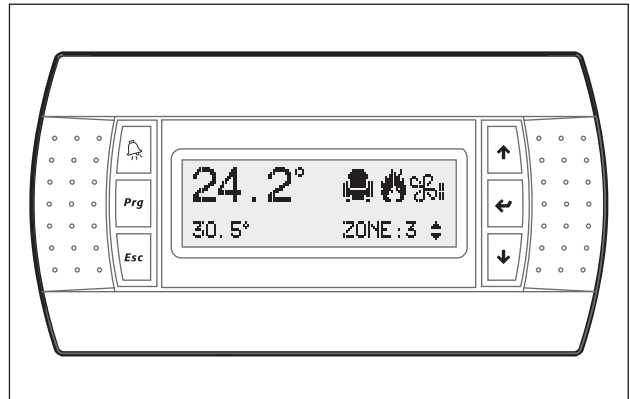

The display is an LCD 4 lines x 20 columns. The quantities and the information about the operation of the unit are alternated in the form of subsequent screens, named.

6.3 Keyboard

Arrows key - Up/Down/Enter

If the cursor is in the top left-hand corner (Home), press the UP/DOWN keys to access the subsequent masks associated to the selected branch. If a mask includes some value setting fields and you press the ENTER key, the cursor will reach these fields.

Once you have reached the quantity setting field, you can modify any value (within the expected limits) by pressing the UP/DOWN keys.

After you have selected the desired value, press the ENTER key again to store it.

6 - Control (continued)

Alarms

Code	Alarm unit description	Comp. Status	Fan Status	Pump Status	Aut/Man Reset	Delay	Notes
AL02	Flow meter/Interbloc alarm	Off	Off	Off	Man	Parameters	
AL03	High pressure "manual reset"	Off	On	On	Man	No	
AL05	Failure of transducer B6-SP	On	Max	On	Auto	10 sec	TXV only
AL07	Failure of transducer B7-DP	On	Max	On	Auto	10 sec	
AL09	Failure of sensor B3-Tair	On	Max	On	Auto	10 sec	
AL11	Failure of sensor B1-Tin	Off	Off	On	Auto	10 sec	
AL12	Failure of sensor B2-Tout	Off	Off	On	Auto	10 sec	
AL13	Failure of sensor B4-Tcoil	On	On	On	Auto	10 sec	
AL15	Failure of sensor B8-T tandem	On	Max	On	Auto	10 sec	
AL17	Maintenance of compressor 1	On	On	On	Man	No	
AL18	Maintenance of compressor 2	On	On	On	Man	No	
AL21	Pump maintenance	Off	Off	Off	Man	No	
AL22	Failure of clock card	On	On	On	Man	No	
AL23	Thermal switch, compressor 1	Off Comp. 1	On	On	Man	No	
AL23a	Thermal switch, compressor 1-AUTO Reset	Off Comp. 1	On	On	Auto		
AL24	Thermal switch, compressor 2	Off Comp. 2	On	On	Man	No	
AL24a	Thermal switch, compressor 2-AUTO Reset	Off Comp. 2	On	On	Auto		
AL27	Low pressure alarm	Off	On	On	Man	Parameters	
AL27a	Low pressure alarm -AUTO Reset	Off	On	On	Auto		
AL29	Thermal switch, fans	Off	Off	On	Man	No	
AL29a	Thermal switch, fans- AUTO Reset	Off	Off	On	Auto		
AL30	Antifreeze alarm	Off	Off	On	Man	No	
AL30a	Antifreeze alarm -AUTO Reset	Off	Off	On	Auto		
AL33	Eprom failure	Off	Off	Off	Man	No	
AL60	High limit discharge temperature	Off	Off	Off	Man	No	
AL60a	High limit discharge temperature	Off	Off	Off	Auto		
AL65	Failure of sensor B5-Ttank	On	On	On	Auto	10 sec	EH off
AL66	EH safety	On	On	On	Auto	No	EH off

6 - Control (continued)

Code	Alarm driver description	CIRC - EEV Status	Notes
AL34	Epron failure driver	Off	Man
AL36	Cable motor EEV driver	Off	Man
AL38	Timeout MOP driver	0%	Auto
AL40	Timeout LOP driver	100%	Auto
AL42	Low SH driver	Run	Auto
AL44	Valve open driver	Off	Auto
AL46	High SH driver	Run	Auto
AL48	Sensor 1 driver	Off	Auto
AL50	Sensor 2 driver	Off	Auto
AL52	Sensor 3 driver	Off	Auto
AL54	GoAhead driver	Run	Auto
AL56	LAN driver	Off	Auto
AL58	Auto set up driver	Off	Auto

Setpoint

Pressing the Set key allows you to enter the Set point level accessible to the user. The parameters that can be set are listed below, along with the limit values and the default values (standard shop settings) :

User parameters	Control mode	Min value	Max value	Default
Cooling Setpoint	RWT Return Control	mCS +2	20	10
	LWT Leaving Control	mCS	20	8
Cooling Setpoint - glycol water	RWT Return Control	-15	20	10
	LWT Leaving Control	-15	20	8
Proportional band	RWT Return Control	1	10	5
	RWT Return Control (EH-heat)	1	20	10
Neutral band	LWT Leaving Control	1	6	2
Heating Setpoint	RWT Return Control	20	MHS -5	40
	LWT Leaving Control	20	MHS	40
Languages	—	ITA ENG FRE GER SPA		ITA
System On/Off				
System 1 #	—	OFF	ON	OFF
System 2 #	—	OFF	ON	OFF
Unit management		Cooling	Heating	

6 - Control (continued)

6.4 Protection and Safety Equipment

Defrosting System (only for AQVSH models)

The AQVSH units are provided with an automatic defrosting system, which prevents the formation of excessive ice banks on coolant/air exchangers during heat pump operation.

This system, which is part of the electronic control system, is of the time/suction pressure type, and when the suction pressure detected by a sensor drops below a fixed limit, once the preset time is over, switches from heating to cooling the operation of the unit, with the fans stopped.

During the defrosting cycle the compressor works normally, but the coil's fans remain off. The defrosting cycle stops after the coil has been defrosted, and at this point the unit can work in heating mode again.

	<p>For safety purposes, fans are started also during defrosting, if the discharge pressure reaches considerable values.</p>
---	---

Frost Protection for the Chilled Fluid

These units are provided with frost protection for the chilled fluid. This protection consists of an electrical resistor positioned in contact with the coolant/circulating fluid exchanger, which is activated (although the unit is off) when the temperature of the fluid drops below 5 °C - the standard value for a non-glycol unit.

If the leaving water temperature drops below 4 °C (standard value for a non-glycol unit) the machine's antifreeze alarm is activated. If the circulating fluid is water, before the beginning of the cold season it is advisable to drain the circuit to prevent water frosting.

If the circuit cannot be drained, it is essential to avoid de-energizing the unit, so as to permit the activation, when necessary, of the frost protection.

Compressor protection

Compressors are equipped with a heating element to prevent oil dilution, which may result in remarkable risks of failure of compressors.

The windings of the compressors' motors are provided with a thermal protection.

For AQVSL and AQVSH models an accessory kit for thermal protection is available, for any overcurrent of scroll compressors, which shall be shop-mounted.

Flow switch

To ensure the correct operation of the unit, a flow switch must be installed, to prevent the unit working in case of insufficient circulation of the chilled fluid.

	<p>The flow switch must be carefully installed, according to the instructions given by the Manufacturer.</p>
---	--

The flow switch must be installed on the pressing side of the circulation pump for the fluid, just upstream of the heat exchanger's inlet. The flow switch must be installed in a horizontal straight length of piping, in a position reasonably far (both upstream and downstream) from localized pressure drops (curves, valves etc.).

Continuous Regulation of the Fan Speed

The fans' speed regulator, if installed, allows the unit to work at an ambient temperature down to -18°C.

7 - Product Description

7.1 General Information

AQVSL/AQVSH units are one-block type with single refrigerant circuit. They are intended to cool down the water required for any air-conditioning application as well as any other fluid, such as for example glycol water. These units are completely assembled at works. They are equipped with all the refrigerating connections and the internal electrical wiring required for a rapid installation on the field. An operation test is performed after assembly, with water flowing through the refrigerant/water exchanger in order to make sure that the refrigerating circuit is properly working. The refrigerating circuit of every unit is pressure tested before inspection, drained and charged with R410A. A low noise level is the result of a careful study. It is achieved on chillers by using technologically advanced components without negatively affecting the operation performances and limits of the units.

7.2 Body and Frame

The base and frame of these units are made with galvanized steel elements, assembled with stainless steel screws. All panels can be removed to ensure easy access to internal components. All galvanized steel parts are protected by epoxy powder paint.

7.3 Compressors

The models are equipped with two SCROLL hermetic tandem compressors with an internal motor protection. The compressors of all models are assembled on rubber shock absorbers. Their motors can be directly started. They are cooled down by the aspirated refrigerant gas and equipped with internal thermistor protections against overloads. Overload protections are automatically reset after having tripped. The compressor terminal box has an IP21/54 protection degree. Compressors are powered on and off by the microprocessor of the unit control system which is intended to control the delivery of the thermal refrigerating capacity.

7.4 Evaporators

Evaporators are made of stainless steel plates. They are thermally insulated by means of a thick flexible insulating mattress with closed cells. The maximum operating pressures correspond to 10 bar for the water side and to 45 bar for the refrigerant side. Antifreeze protection for the water in the exchangers is ensured by electrical heaters and differential pressure switches.

7.5 Condensing/evaporating coils

Coils are of reversible type and are made of copper tubes arranged in staggered rows and mechanically expanded inside an aluminium finned pack. The maximum operating pressure on the refrigerant side of the condensing coils is 45 bar. The condensing coils mounted on cooling only units are of microchannel type.

7.6 Condenser Fans

The condenser fans are of a helical type. They are directly coupled and have an impeller with wing contoured aluminium blades. Each fan is equipped with a galvanised steel accident-prevention protection which is painted after manufacture. The fans motors are completely closed. They have an IP54 protection degree and a protection thermostat embedded in the windings.

7.7 Fans Control

All models have a step speed controller as a standard. It will act according to the condensing pressure and allow the operation down to an Air temperature operation of +10°C.

7.8 Refrigerating Circuit

Each unit has a single refrigerating circuit equipped with external service valves intended to measure the refrigerant pressure and charge, sight glass with a humidity indicator, dryer filter and thermal expansion valve. Refrigerating circuit is also complete with high pressure switch as well as high and low transducer.

7.9 Control Supply Panel

All components of the control system and those necessary to start the motors are shop connected and tested. The control compartment contains an electronic card and a control board with an external keyboard and display, to show the operational functions, as well as the intervention of the alarms and the working blocks.

7 - Product Description (continued)

Refrigerant flow diagram - AQVSL STAR 85 to 160

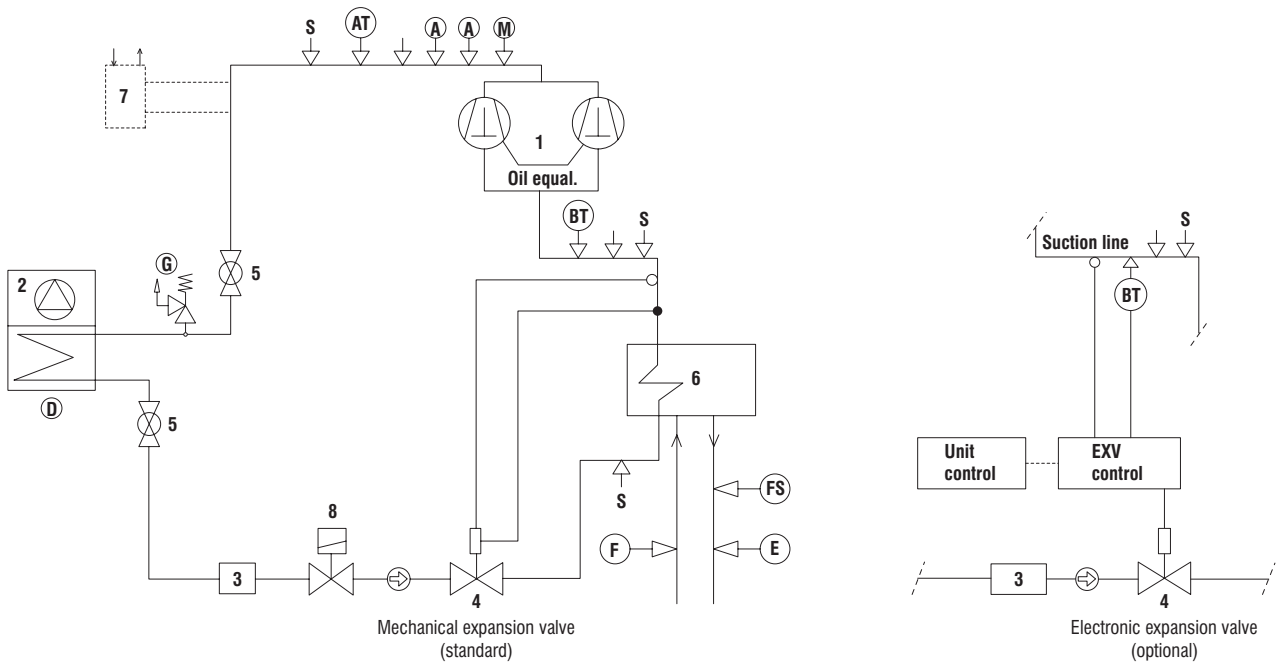

COMPONENTS	VESSEL CATEGORY (≥ 2) / EVALUATION MODULE
1 Compressor tandem scroll type	Sizes 85-140 : 2 / Mod. D1 - Size 160 : 2-3* / Mod. H - Mod. D1*
2 Air cooled condenser	
3 Filter drier	
4 Electronic/mechanical expansion valve	
5 Globe valve	
6 Plate heat exchanger	2 / Mod. B+D
7 Desuperheater (optional)	
8 Solenoid valve	

* According to compressor manufacturer.

SAFETY / CONTROL DEVICES	HAZARD CATEGORY / EVALUATION MODULE
A High pressure switch (40.5 bar)	4 / Mod. B+D
AT High pressure transducer	
BT Low pressure transducer	
FS Water flow switch	
D Air temperature sensor	
E Outlet water temperature sensor	
F Inlet water temperature sensor	
G PED pressure relief valve (45 bar)	4 / Mod. H1 - Mod. B+D**
M Discharge temperature sensor	
S 5/16" Schrader connection (service only)	
↓ Pipe connection with Schrader valve	

** According to valve manufacturer.

7 - Product Description (continued)

Refrigerant flow diagram - AQVSH STAR 85 to 160

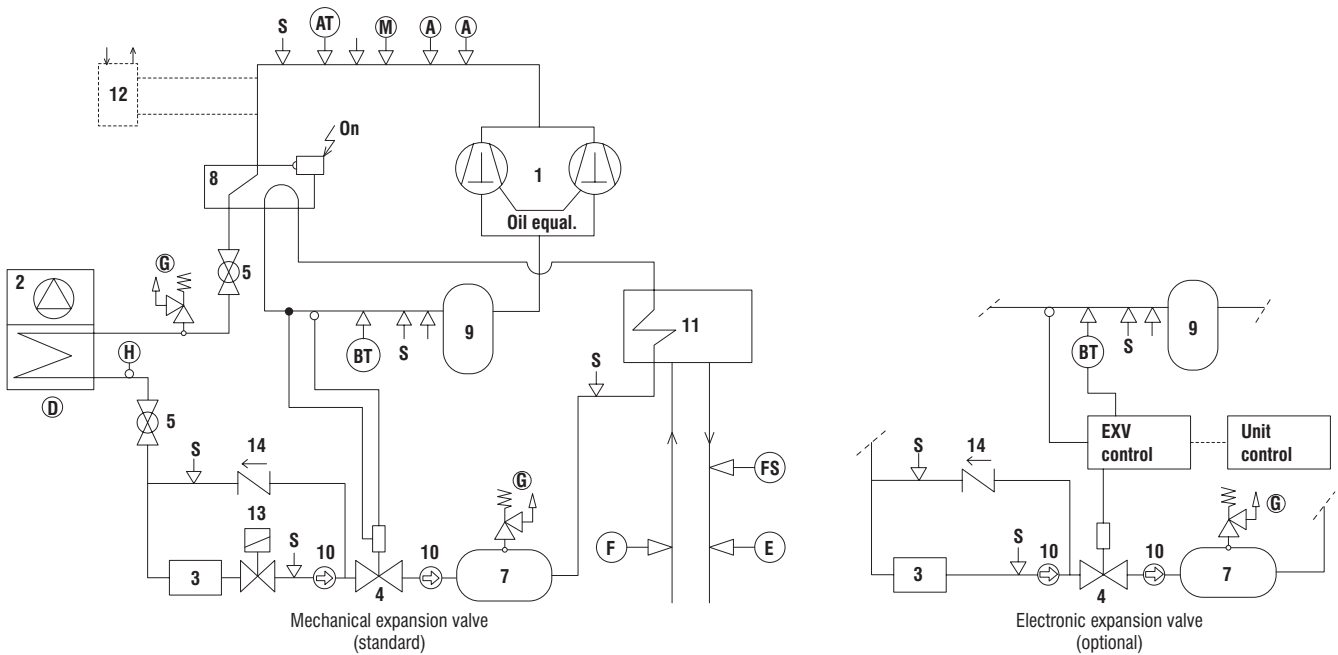

COMPONENTS	VESSEL CATEGORY (≥ 2) / EVALUATION MODULE
1 Compressor tandem scroll type	Sizes 85-140 : 2 / Mod. D1 - Size 160 : 2-3* / Mod. H - Mod. D1*
2 Air cooled heat exchanger	
3 Filter drier	
4 Electronic/mechanical expansion valve	
5 Globe valve	
7 Liquid receiver	2 / Mod. D1
8 Four-way valve	
9 Suction accumulator	2 / Mod. D1
10 Sight glass	
11 Plate heat exchanger	2 / Mod. B+D
12 Desuperheater (optional)	
13 Solenoid valve	
14 Check valve	

* According to compressor manufacturer.

SAFETY / CONTROL DEVICES	HAZARD CATEGORY / EVALUATION MODULE
A High pressure switch (40.5 bar)	4 / Mod. B+D
AT High pressure transducer	
BT Low pressure transducer	
FS Water flow switch	
D Air temperature sensor	
E Outlet water temperature sensor	
F Inlet water temperature sensor	
G PED pressure relief valve (45 bar)	4 / Mod. H1 - Mod. B+D**
H Defrost temperature sensor	
M Discharge temperature sensor	
S 5/16" Schrader connection (service only)	
↓ Pipe connection with Schrader valve	

** According to valve manufacturer.

8 - Technical Data

8.1 Pressure drops

PRESSURE DROP IN THE EVAPORATOR *							
		85	95	115	125	140	160
K	kPa/(l/s) ^ 2	1.61	1.61	1.15	1.15	0.81	0.81
Minimum flow rate	l/s	2.5	2.8	3.2	3.6	4.0	4.7
Nominal flow rate	l/s	3.9	4.5	5.1	5.8	6.4	7.5
Maximum flow rate	l/s	6.6	7.6	8.4	9.6	10.7	12.5
Minimum pressure drop	kPa	9.7	12.9	11.5	15.1	13.0	17.8
Nominal pressure drop	kPa	24.9	33.0	29.5	38.6	33.3	45.6
Maximum pressure drop	kPa	69.0	91.8	82.0	107.1	92.5	126.7

$$\Delta P = K \cdot Q^2$$

* Data refer to BLN version

PRESSURE DROP IN THE DESUPERHEATER *							
		85	95	115	125	140	160
K	kPa/(l/s) ^ 2	20.61	20.61	14.26	14.26	9.33	9.33
Minimum flow rate	l/s	0.6	0.7	0.8	1.0	1.1	1.3
Nominal flow rate	l/s	1.0	1.2	1.3	1.5	1.7	2.0
Maximum flow rate	l/s	1.7	2.0	2.2	2.6	2.9	3.3
Minimum pressure drop	kPa	8.4	11.2	10.1	13.2	10.9	14.7
Nominal pressure drop	kPa	21.4	28.6	25.8	33.7	27.8	37.5
Maximum pressure drop	kPa	59.6	79.4	71.6	93.5	77.3	104.3

$$\Delta P = K \cdot Q^2$$

* Data refer to BLN version

8 - Technical Data (continued)

8.2 Technical data

AQVSL STAR BLN		85	95	115	125	140	160
Power supply	V/ph/Hz	400 (± 10%) / 3 / 50					
Number of refrigerant circuits		1	1	1	1	1	1
Total capacity steps	%	0-50-100	0-43-100	0-50-100	0-44-100	0-50-100	0-50-100
REFRIGERANT							
Type		R410A					
Charge (1)	kg	10	11	13	15	16	19
COMPRESSORS							
Type		Scroll					
Number		2	2	2	2	2	2
Start-up type		Direct					
Oil type		POE					
N°of loading stages		0/100	0/100	0/100	0/100	0/100	0/100
EVAPORATOR							
Type		Plate					
Number		1	1	1	1	1	1
Water flow rate	l/s	3.9	4.5	5.1	5.8	6.4	7.5
Pressure drop	kPa	Refer to Chap. 8.4					
DESUPERHEATER							
Type		Plate					
Number		1	1	1	1	1	1
Water flow rate	l/s	1.0	1.2	1.3	1.5	1.7	2.0
Pressure drop	kPa	Refer to Chap. 8.4					
FANS							
Type		Axial					
Number		2	3	2	2	2	3
Nominal speed	rpm	690	690	900	900	900	900
Air flow rate	m³/s	10.1	13.9	12.5	12.2	12.2	17.3
Power input	kW	2.3	3.5	3.6	3.6	3.6	5.4
AIR COOLED CONDENSER							
Type		Microchannel					
Number of coils		2	2	2	2	2	2
Total coil face area per coil	m²	2.5	2.5	2.5	2.5	2.5	2.5
HYDRAULIC CONNECTIONS (EVAPORATOR)							
Type		Victaulic					
Inlet diameter	inch	2"1/2	2"1/2	2"1/2	2"1/2	2"1/2	2"1/2
Outlet diameter	inch	2"1/2	2"1/2	2"1/2	2"1/2	2"1/2	2"1/2
HYDRAULIC CONNECTIONS (DESUPERHEATER)							
Type		Male gas threaded					
Inlet diameter	inch	1"	1"	1"	1"	1"	1"
Outlet diameter	inch	1"	1"	1"	1"	1"	1"
WEIGHT							
Shipping weight	kg	Refer to Chap. 8.5					
Operating weight	kg						
DIMENSIONS							
Length	mm	2950	2950	2950	2950	2950	2950
Width	mm	1110	1110	1110	1110	1110	1110
Height	mm	2250	2250	2250	2250	2250	2250

(1) Indicative value. Always refer to the value specified on the unit's label

8 - Technical Data (continued)

AQVSL STAR ELN		85	95	115	125	140	160
Power supply	V/ph/Hz	400 (± 10%) / 3 / 50					
Number of refrigerant circuits		1	1	1	1	1	1
Total capacity steps	%	0-50-100	0-43-100	0-50-100	0-44-100	0-50-100	0-50-100
REFRIGERANT							
Type		R410A					
Charge (1)	kg	10	11	12	14	16	18
COMPRESSORS							
Type		Scroll					
Number		2	2	2	2	2	2
Start-up type		Direct					
Oil type		POE					
N°of loading stages		0/100	0/100	0/100	0/100	0/100	0/100
EVAPORATOR							
Type		Plate					
Number		1	1	1	1	1	1
Water flow rate	l/s	3.8	4.4	4.9	5.6	6.2	7.3
Pressure drop	kPa	Refer to Chap. 8.4					
DESUPERHEATER							
Type		Plate					
Number		1	1	1	1	1	1
Water flow rate	l/s	1.0	1.2	1.3	1.5	1.7	2.0
Pressure drop	kPa	Refer to Chap. 8.4					
FANS							
Type		Axial					
Number		2	3	2	2	2	3
Nominal speed	rpm	550	550	690	690	690	690
Air flow rate	m³/s	8.3	11.2	10.1	10.2	10.2	14.2
Power input	kW	1.4	2.1	2.3	2.3	2.3	3.5
AIR COOLED CONDENSER							
Type		Microchannel					
Number of coils		2	2	2	2	2	2
Total coil face area per coil	m²	2.5	2.5	2.5	2.5	2.5	2.5
HYDRAULIC CONNECTIONS (EVAPORATOR)							
Type		Victaulic					
Inlet diameter	inch	2"1/2	2"1/2	2"1/2	2"1/2	2"1/2	2"1/2
Outlet diameter	inch	2"1/2	2"1/2	2"1/2	2"1/2	2"1/2	2"1/2
HYDRAULIC CONNECTIONS (DESUPERHEATER)							
Type		Male gas threaded					
Inlet diameter	inch	1"	1"	1"	1"	1"	1"
Outlet diameter	inch	1"	1"	1"	1"	1"	1"
WEIGHT							
Shipping weight	kg	Refer to Chap. 8.5					
Operating weight	kg						
DIMENSIONS							
Length	mm	2950	2950	2950	2950	2950	2950
Width	mm	1110	1110	1110	1110	1110	1110
Height	mm	2250	2250	2250	2250	2250	2250

(1) Indicative value. Always refer to the value specified on the unit's label

8 - Technical Data (continued)

AQVSL STAR HT		85	95	115	125	140	160
Power supply	V/ph/Hz	400 (± 10%) / 3 / 50					
Number of refrigerant circuits		1	1	1	1	1	1
Total capacity steps	%	0-50-100	0-43-100	0-50-100	0-44-100	0-50-100	0-50-100
REFRIGERANT							
Type		R410A					
Charge (1)	kg	10	12	13	15	17	19
COMPRESSOR							
Type		Scroll					
Number		2	2	2	2	2	2
Start-up type		Direct					
Oil type		POE					
N°of loading stages		0/100	0/100	0/100	0/100	0/100	0/100
EVAPORATOR							
Type		Plate					
Number		1	1	1	1	1	1
Water flow rate	l/s	4.1	4.7	5.2	5.9	6.6	7.7
Pressure drop	kPa	Refer to Chap. 8.4					
DESUPERHEATER							
Type		Plate					
Number		1	1	1	1	1	1
Water flow rate	l/s	1.0	1.2	1.4	1.5	1.7	2.0
Pressure drop	kPa	Refer to Chap. 8.4					
FANS							
Type		Axial					
Number		2	3	2	2	2	3
Nominal speed	rpm	1100	1100	1100	1100	1100	1100
Air flow rate	m³/s	15.0	21.1	14.8	14.1	14.1	20.2
Power input	kW	5.3	8.0	5.3	5.3	5.3	8.0
AIR COOLED CONDENSER							
Type		Microchannel					
Number of coils		2	2	2	2	2	2
Total coil face area per coil	m²	2.5	2.5	2.5	2.5	2.5	2.5
HYDRAULIC CONNECTIONS (EVAPORATOR)							
Type		Victaulic					
Inlet diameter	inch	2"1/2	2"1/2	2"1/2	2"1/2	2"1/2	2"1/2
Outlet diameter	inch	2"1/2	2"1/2	2"1/2	2"1/2	2"1/2	2"1/2
HYDRAULIC CONNECTIONS (DESUPERHEATER)							
Type		Male gas threaded					
Inlet diameter	inch	1"	1"	1"	1"	1"	1"
Outlet diameter	inch	1"	1"	1"	1"	1"	1"
WEIGHT							
Shipping weight	kg	Refer to Chap. 8.5					
Operating weight	kg						
DIMENSIONS							
Length	mm	2950	2950	2950	2950	2950	2950
Width	mm	1110	1110	1110	1110	1110	1110
Height	mm	2250	2250	2250	2250	2250	2250

(1) Indicative value. Always refer to the value specified on the unit's label

8 - Technical Data (continued)

AQVSH STAR BLN		85	95	115	125	140	160
Power supply	V/ph/Hz	400 (± 10%) / 3 / 50					
Number of refrigerant circuits		1	1	1	1	1	1
Total capacity steps	%	0-50-100	0-43-100	0-50-100	0-44-100	0-50-100	0-50-100
REFRIGERANT							
Type		R410A					
Charge (1)	kg	17	20	24	26	30	35
COMPRESSOR							
Type		Scroll					
Number		2	2	2	2	2	2
Start-up type		Direct					
Oil type		POE					
N°of loading stages		0/100	0/100	0/100	0/100	0/100	0/100
EVAPORATOR							
Type		Plate					
Number		1	1	1	1	1	1
Water flow rate	l/s	3.6	4.1	4.9	5.5	6.3	7.3
Pressure drop	kPa	Refer to Chap. 8.4					
DESUPERHEATER							
Type		Plate					
Number		1	1	1	1	1	1
Water flow rate	l/s	1.0	1.1	1.3	1.5	1.7	2.0
Pressure drop	kPa	Refer to Chap. 8.4					
FANS							
Type		Axial					
Number		2	3	2	2	2	3
Nominal speed	rpm	690	690	900	900	900	900
Air flow rate	m³/s	9.9	13.4	11.7	11.7	11.1	14.5
Power input	kW	2.3	3.5	3.6	3.6	3.6	5.4
AIR COOLED CONDENSER							
Type		Finned tubes					
Number of coils		2	2	2	2	2	2
Total coil face area per coil	m²	2.5	2.5	2.5	2.5	2.5	2.5
HYDRAULIC CONNECTIONS (EVAPORATOR)							
Type		Victaulic					
Inlet diameter	inch	2"1/2	2"1/2	2"1/2	2"1/2	2"1/2	2"1/2
Outlet diameter	inch	2"1/2	2"1/2	2"1/2	2"1/2	2"1/2	2"1/2
HYDRAULIC CONNECTIONS (DESUPERHEATER)							
Type		Male gas threaded					
Inlet diameter	inch	1"	1"	1"	1"	1"	1"
Outlet diameter	inch	1"	1"	1"	1"	1"	1"
WEIGHT							
Shipping weight	kg	Refer to Chap. 8.5					
Operating weight	kg						
DIMENSIONS							
Length	mm	2950	2950	2950	2950	2950	2950
Width	mm	1110	1110	1110	1110	1110	1110
Height	mm	2250	2250	2250	2250	2250	2250

(1) Indicative value. Always refer to the value specified on the unit's label

8 - Technical Data (continued)

AQVSH STAR ELN		85	95	115	125	140	160
Power supply	V/ph/Hz	400 (± 10%) / 3 / 50					
Number of refrigerant circuits		1	1	1	1	1	1
Total capacity steps	%	0-50-100	0-43-100	0-50-100	0-44-100	0-50-100	0-50-100
REFRIGERANT							
Type		R410A					
Charge (1)	kg	17	19	23	25	29	33
COMPRESSOR							
Type		Scroll					
Number		2	2	2	2	2	2
Start-up type		Direct					
Oil type		POE					
N°of loading stages		0/100	0/100	0/100	0/100	0/100	0/100
EVAPORATOR							
Type		Plate					
Number		1	1	1	1	1	1
Water flow rate	l/s	3.5	3.9	4.7	5.2	6.0	6.9
Pressure drop	kPa	Refer to Chap. 8.4					
DESUPERHEATER							
Type		Plate					
Number		1	1	1	1	1	1
Water flow rate	l/s	1.0	1.1	1.3	1.5	1.7	1.9
Pressure drop	kPa	Refer to Chap. 8.4					
FANS							
Type		Axial					
Number		2	3	2	2	2	3
Nominal speed	rpm	550	550	690	690	690	690
Air flow rate	m³/s	8.5	11.1	9.4	9.4	8.9	11.1
Power input	kW	1.4	2.1	2.3	2.3	2.3	3.5
AIR COOLED CONDENSER							
Type		Finned tubes					
Number of coils		2	2	2	2	2	2
Total coil face area per coil	m²	2.5	2.5	2.5	2.5	2.5	2.5
HYDRAULIC CONNECTIONS (EVAPORATOR)							
Type		Victaulic					
Inlet diameter	inch	2"1/2	2"1/2	2"1/2	2"1/2	2"1/2	2"1/2
Outlet diameter	inch	2"1/2	2"1/2	2"1/2	2"1/2	2"1/2	2"1/2
HYDRAULIC CONNECTIONS (DESUPERHEATER)							
Type		Male gas threaded					
Inlet diameter	inch	1"	1"	1"	1"	1"	1"
Outlet diameter	inch	1"	1"	1"	1"	1"	1"
WEIGHT							
Shipping weight	kg	Refer to Chap. 8.5					
Operating weight	kg						
DIMENSIONS							
Length	mm	2950	2950	2950	2950	2950	2950
Width	mm	1110	1110	1110	1110	1110	1110
Height	mm	2250	2250	2250	2250	2250	2250

(1) Indicative value. Always refer to the value specified on the unit's label

8 - Technical Data (continued)

AQVSH STAR HT		85	95	115	125	140	160
Power supply	V/ph/Hz	400 (± 10%) / 3 / 50					
Number of refrigerant circuits		1	1	1	1	1	1
Total capacity steps	%	0-50-100	0-43-100	0-50-100	0-44-100	0-50-100	0-50-100
REFRIGERANT							
Type		R410A					
Charge (1)	kg	19	21	24	27	31	36
COMPRESSOR							
Type		Scroll					
Number		2	2	2	2	2	2
Start-up type		Direct					
Oil type		POE					
N°of loading stages		0/100	0/100	0/100	0/100	0/100	0/100
EVAPORATOR							
Type		Plate					
Number		1	1	1	1	1	1
Water flow rate	l/s	3.8	4.4	5.0	5.6	6.5	7.5
Pressure drop	kPa	Refer to Chap. 8.4					
DESUPERHEATER							
Type		Plate					
Number		1	1	1	1	1	1
Water flow rate	l/s	1.0	1.1	1.3	1.5	1.7	2.0
Pressure drop	kPa	Refer to Chap. 8.4					
FANS							
Type		Axial					
Number		2	3	2	2	2	3
Nominal speed	rpm	1100	1100	1100	1100	1100	1100
Air flow rate	m³/s	14.2	20.1	13.8	13.8	13.2	17.8
Power input	kW	5.3	8.0	5.3	5.3	5.3	8.0
AIR COOLED CONDENSER							
Type		Finned tubes					
Number of coils		2	2	2	2	2	2
Total coil face area per coil	m²	2.5	2.5	2.5	2.5	2.5	2.5
HYDRAULIC CONNECTIONS (EVAPORATOR)							
Type		Victaulic					
Inlet diameter	inch	2"1/2	2"1/2	2"1/2	2"1/2	2"1/2	2"1/2
Outlet diameter	inch	2"1/2	2"1/2	2"1/2	2"1/2	2"1/2	2"1/2
HYDRAULIC CONNECTIONS (DESUPERHEATER)							
Type		Male gas threaded					
Inlet diameter	inch	1"	1"	1"	1"	1"	1"
Outlet diameter	inch	1"	1"	1"	1"	1"	1"
WEIGHT							
Shipping weight	kg	Refer to Chap. 8.5					
Operating weight	kg						
DIMENSIONS							
Length	mm	2950	2950	2950	2950	2950	2950
Width	mm	1110	1110	1110	1110	1110	1110
Height	mm	2250	2250	2250	2250	2250	2250

(1) Indicative value. Always refer to the value specified on the unit's label

8 - Technical Data (continued)

8.3 Unit electrical data

AQVSL/AQVSH STAR BLN		85	95	115	125	140	160
Rated voltage	V/ph/Hz	400 ($\pm 10\%$) / 3 / 50					
Max. absorbed power	kW	37	45	51	57	64	76
Rated current	A	50	62	69	79	89	100
Max. current FLA	A	82	94	110	124	138	169
Max. start-up current LRA	A	240	258	274	319	333	410
External fuses	A	100	125	125	160	160	200
Max. cable section (*)	mm ²	25	25	25	35	35	50
Exchanger resistance rated voltage	V/ph/Hz	230 ($\pm 10\%$) / 1 / 50					
Exchanger resistance max. absorbed power	W	130					

AQVSL/AQVSH STAR ELN		85	95	115	125	140	160
Rated voltage	V/ph/Hz	400 ($\pm 10\%$) / 3 / 50					
Max. absorbed power	kW	37	45	50	56	62	74
Rated current	A	50	62	66	76	85	95
Max. current FLA	A	82	94	106	120	134	165
Max. start-up current LRA	A	240	258	270	315	329	406
External fuses	A	100	125	125	160	160	200
Max. cable section (*)	mm ²	25	25	25	35	35	50
Exchanger resistance rated voltage	V/ph/Hz	230 ($\pm 10\%$) / 1 / 50					
Exchanger resistance max. absorbed power	W	130					

AQVSL/AQVSH STAR HT/HPF		85	95	115	125	140	160
Rated voltage	V/ph/Hz	400 ($\pm 10\%$) / 3 / 50					
Max. absorbed power	kW	40	49	53	59	65	79
Rated current	A	54	68	70	79	89	100
Max. current FLA	A	85	99	110	124	138	170
Max. start-up current LRA	A	244	263	274	319	333	411
External fuses	A	100	125	125	160	160	200
Max. cable section (*)	mm ²	25	25	25	35	35	50
Exchanger resistance rated voltage	V/ph/Hz	230 ($\pm 10\%$) / 1 / 50					
Exchanger resistance max. absorbed power	W	130					

(*) The dimensioning of the unit's power cables is the responsibility of the installer, who shall consider: the rating, the maximum working temperature in the room, the type of insulation and the cable laying, the maximum length of the power supply line.

8 - Technical Data (continued)

Compressors electrical data

AQVSL/AQVSH STAR BLN/ELN/HT/HPF		85	95	115	125	140	160
Number	-	2	2	2	2	2	2
Nominal power input	kW	12.5 x 2	12.5 + 17.0	17.0 x 2	17.0 + 21.9	2 x 21.9	2 x 25.7
Max. absorbed power	kW	17.4 x 2	17.3 + 23.8	2 x 23.8	23.8 + 30.0	2 x 30.0	2 x 35.4
Rated current	A	23.0 x 2	24.6 + 30.8	2 x 30.8	30.8 + 40.5	2 x 40.5	2 x 44.1
Max. current	A	38.6 x 2	36.0 + 51.0	2 x 51.0	51.0 + 65.0	2 x 65.0	2 x 79.0
Oil pan resistor	W	80 x 2	56 x 2	56 x 2	56 x 2	56 x 2	80 x 2

Fans electrical data

AQVSL/AQVSH STAR BLN		85	95	115	125	140	160
Rated voltage	V/ph/Hz	400 (± 10%) / 3 / 50					
Number	-	2	3	2	2	2	3
Rated power	kW	1.2	1.2	1.8	1.8	1.8	1.8
Absorbed rated current FLA	A	2.2	2.2	3.8	3.8	3.8	3.8

AQVSL/AQVSH STAR ELN		85	95	115	125	140	160
Rated voltage	V/ph/Hz	400 (± 10%) / 3 / 50					
Number	-	2	3	2	2	2	3
Rated power	kW	1.2	1.2	1.2	1.2	1.2	1.2
Absorbed rated current FLA	A	2.2	2.2	2.2	2.2	2.2	2.2

AQVSL/AQVSH STAR HT/HPF		85	95	115	125	140	160
Rated voltage	V/ph/Hz	400 (± 10%) / 3 / 50					
Number	-	2	3	2	2	2	3
Rated power	kW	2.7	2.7	2.7	2.7	2.7	2.7
Absorbed rated current FLA	A	4.1	4.1	4.1	4.1	4.1	4.1

Pumps electrical data

AQVSL/AQVSH STAR 1/2 P		85	95	115	125	140	160
Rated voltage	V/ph/Hz	400 (± 10%) / 3 / 50					
Rated power	kW	2.0	2.0	2.5	2.5	3.6	3.6
Absorbed rated current FLA	A	3.7	3.7	5.0	5.0	6.4	6.4

AQVSL/AQVSH STAR 3 P		85	95	115	125	140	160
Rated voltage	V/ph/Hz	400 (± 10%) / 3 / 50					
Rated power	kW	1.4	1.4	1.4	1.8	1.8	1.8
Absorbed rated current FLA	A	2.7	2.7	2.7	3.5	3.5	3.5

8 - Technical Data (continued)

8.4 Hydraulic features

Water pump curves - AQVSL/AQVSH STAR - 1 or 2 pump available static pressure (1P/2P-SP)

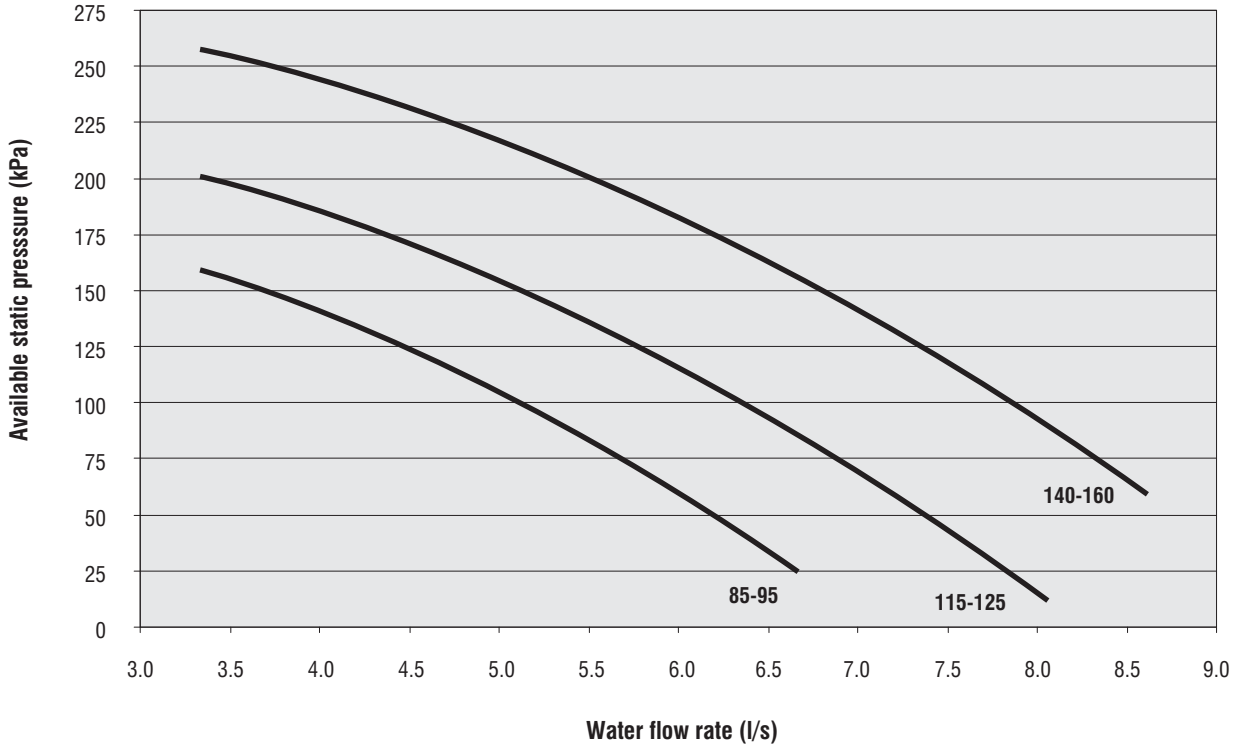

Water pump curves - AQVSL/AQVSH STAR - 3 pump available static pressure (3P-SP)

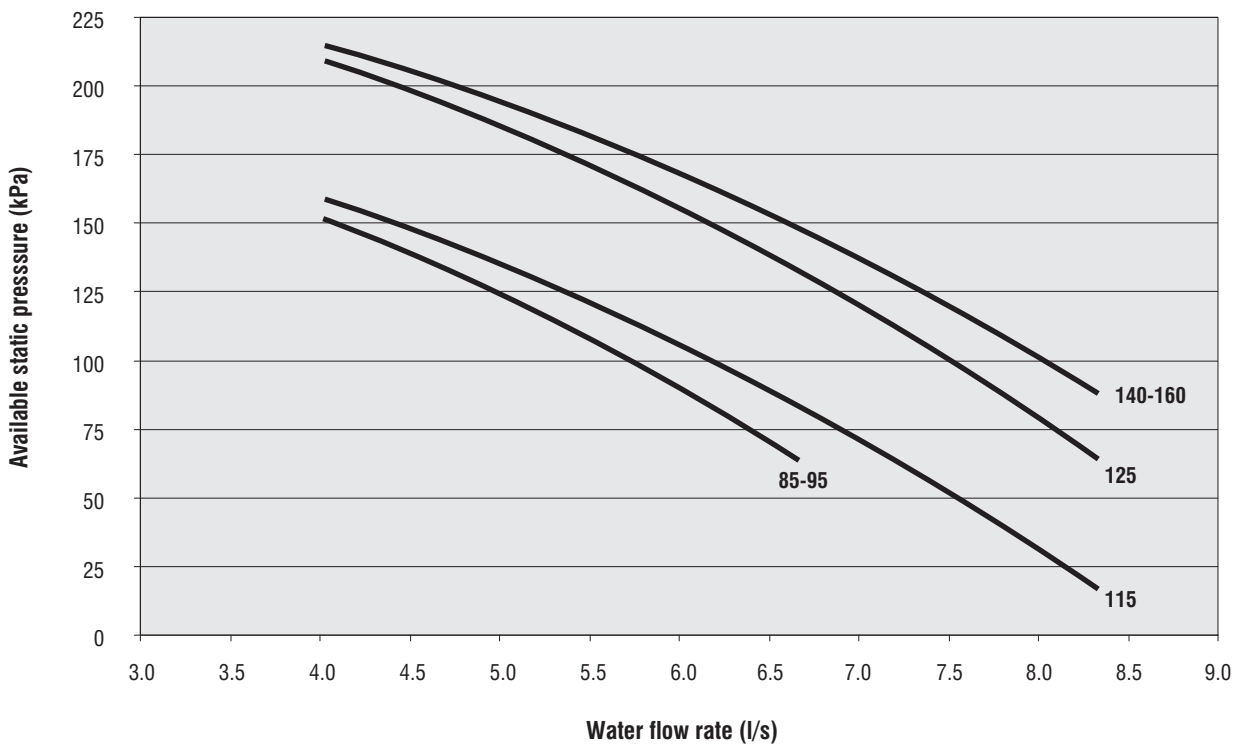

8 - Technical Data (continued)

Water pump curves - AQVSL/AQVSH STAR - 1 or 2 pump available static pressure (1P/2P-HP)

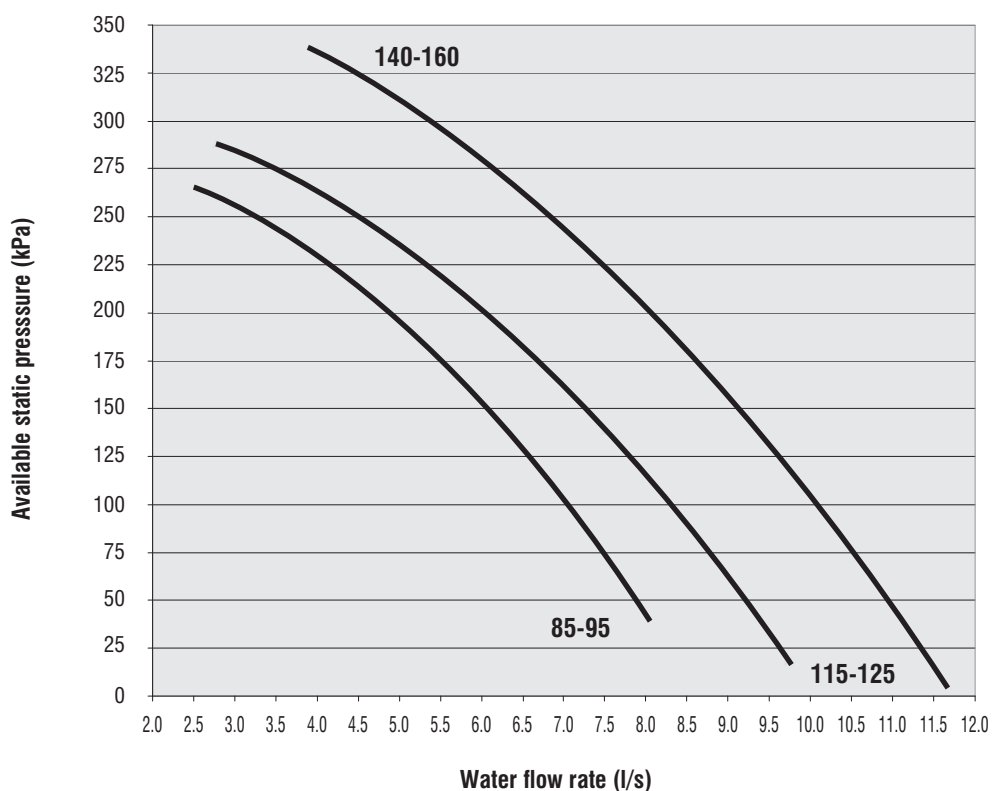

Pump Data - 400V/3/50Hz		1P-SP		2P-SP	
Size	Model	P _{max-pump} (kW)	I _{max-pump} FLA (A)	P _{max-pump} (kW)	I _{max-pump} FLA (A)
85	CEA 370/2	2.0	3.7	2.0	3.7
95	CEA 370/2	2.0	3.7	2.0	3.7
115	CEA 370/3	2.5	5.0	2.5	5.0
125	CEA 370/3	2.5	5.0	2.5	5.0
140	CEA 370/5	3.6	6.4	3.6	6.4
160	CEA 370/5	3.6	6.4	3.6	6.4

Pump Data - 400V/3/50Hz		3P-SP	
Size	Model	P _{max-pump} (kW)	I _{max-pump} FLA (A)
85	CEA 210/3	1.4	2.7
95	CEA 210/3	1.4	2.7
115	CEA 210/3	1.4	2.7
125	CEA 210/4	1.8	3.5
140	CEA 210/4	1.8	3.5
160	CEA 210/4	1.8	3.5

Pump Data - 400V/3/50Hz		1P-HP		2P-HP	
Size	Model	P _{max-pump} (kW)	I _{max-pump} FLA (A)	P _{max-pump} (kW)	I _{max-pump} FLA (A)
85	CEA 370/5	3.6	6.4	3.6	6.4
95	CEA 370/5	3.6	6.4	3.6	6.4
115	FHE 40-160/30	3.0	6.3	3.0	6.3
125	FHE 40-160/30	3.0	6.3	3.0	6.3
140	FHE 40-160/40	4.0	7.7	4.0	7.7
160	FHE 40-160/40	4.0	7.7	4.0	7.7

8 - Technical Data (continued)

Evaporator water pressure drop - AQVSL STAR

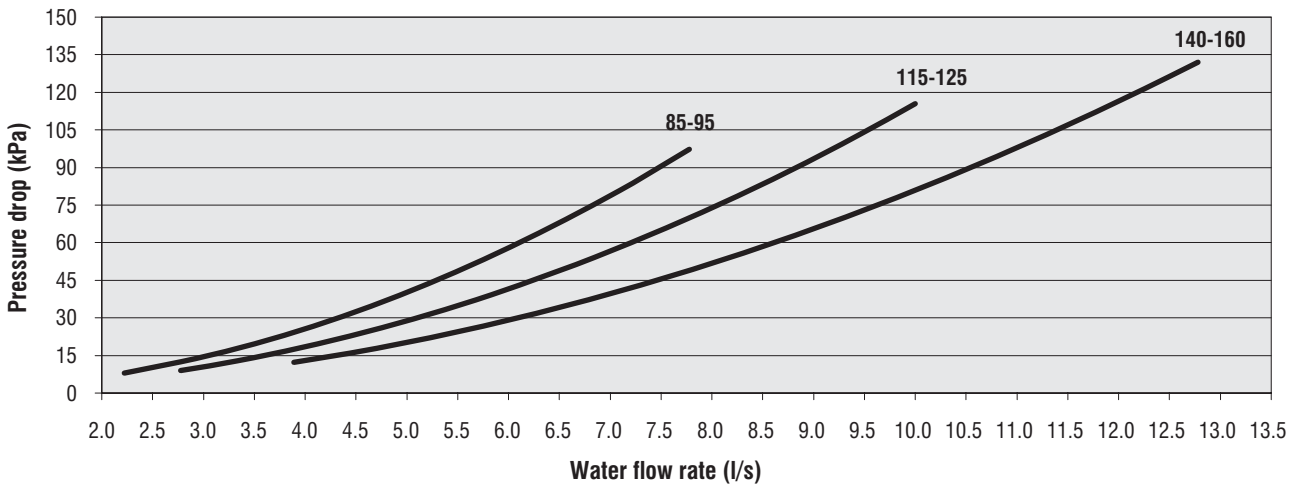

Evaporator water pressure drop - AQVSH STAR

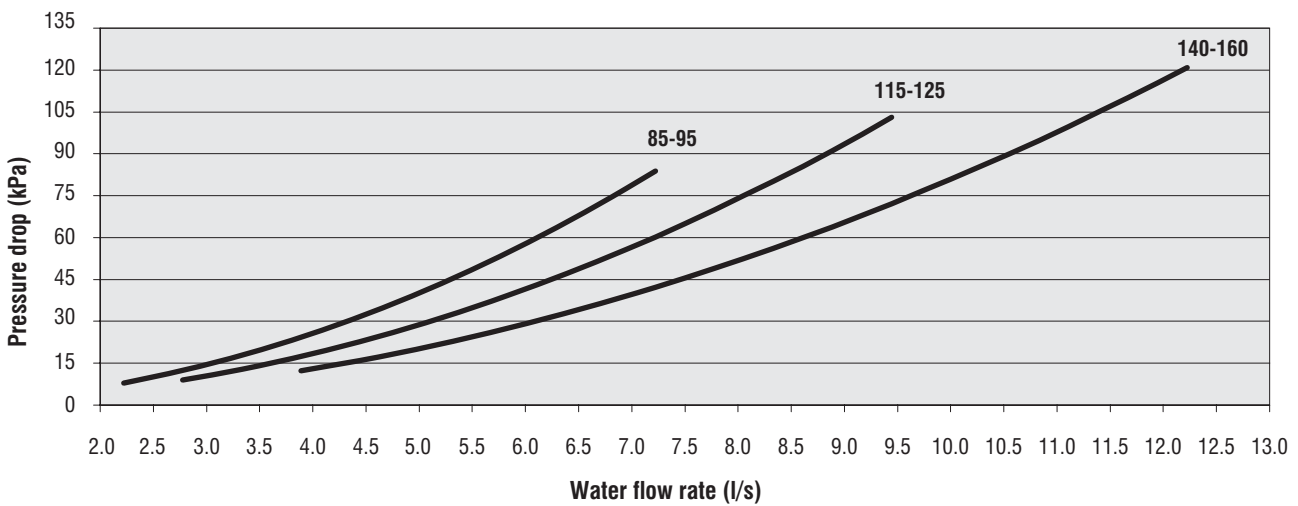

Desuperheater water pressure drop - AQVSL/AQVSH STAR

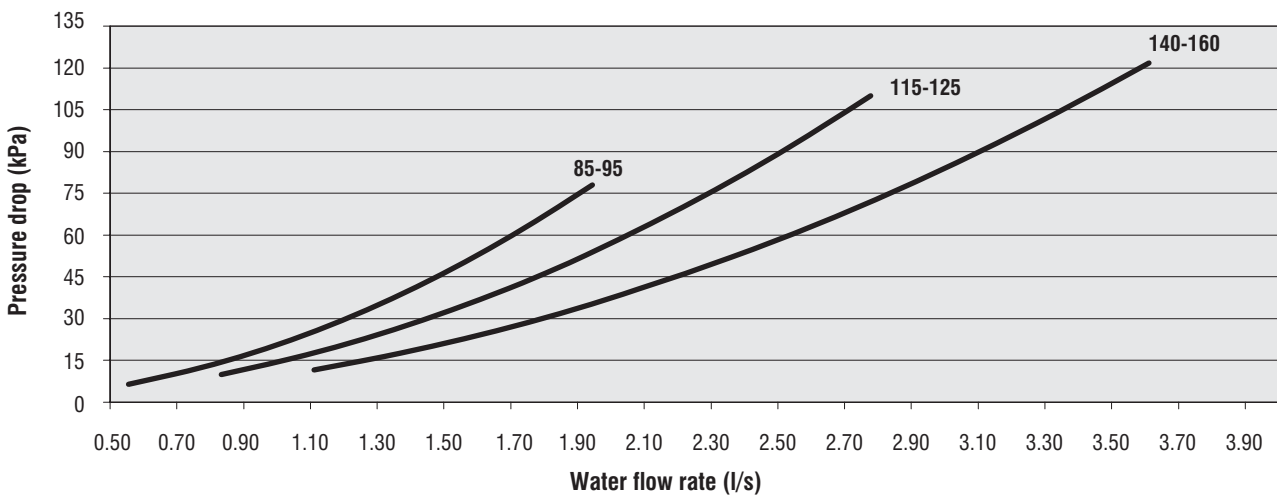

8 - Technical Data (continued)

8.5 Position of shock adsorbers and weight distribution on supports

AQVSL STAR	Weight distribution (kg)				Operating weight (kg)	Shipping weight (kg)	P1-P4 coordinates		CG coordinates	
	P1	P2	P3	P4			a (mm)	b (mm)	x (mm)	y (mm)
85	308	323	160	175	965	945	1021	1780	564	1731
95	366	398	143	175	1083	1062	1021	1780	579	1824
115	380	425	161	206	1172	1148	1021	1780	588	1790
125	386	436	161	210	1194	1170	1021	1780	591	1794
140	411	462	182	233	1288	1261	1021	1780	588	1775
160	447	506	180	239	1373	1345	1021	1780	592	1804
85 1P-SP	325	339	166	180	1009	978	1021	1780	563	1739
95 1P-SP	371	402	162	193	1127	1096	1021	1780	577	1788
115 1P-SP	385	429	180	224	1217	1184	1021	1780	585	1757
125 1P-SP	391	440	180	228	1239	1206	1021	1780	589	1762
140 1P-SP	417	466	202	252	1337	1299	1021	1780	586	1743
160 1P-SP	452	510	201	258	1421	1384	1021	1780	590	1773
85 2P-SP	326	343	170	187	1025	995	1021	1780	565	1729
95 2P-SP	372	405	166	200	1143	1112	1021	1780	578	1778
115 2P-SP	386	432	185	232	1235	1201	1021	1780	587	1747
125 2P-SP	392	444	185	236	1257	1223	1021	1780	590	1752
140 2P-SP	418	471	208	261	1358	1320	1021	1780	588	1733
160 2P-SP	454	515	206	268	1442	1405	1021	1780	592	1763
85 3P-SP	325	347	171	193	1037	1006	1021	1780	570	1722
95 3P-SP	371	409	168	206	1154	1123	1021	1780	583	1771
115 3P-SP	384	438	187	240	1250	1216	1021	1780	592	1739
125 3P-SP	391	449	186	244	1270	1236	1021	1780	595	1745
140 3P-SP	416	474	208	266	1364	1326	1021	1780	592	1730
160 3P-SP	452	518	206	273	1449	1411	1021	1780	595	1760
85 1P-SP T	340	354	370	384	1447	1094	1021	1780	558	1421
95 1P-SP T	385	416	366	397	1564	1211	1021	1780	569	1480
115 1P-SP T	399	443	384	428	1655	1299	1021	1780	576	1474
125 1P-SP T	406	455	384	433	1677	1321	1021	1780	578	1481
140 1P-SP T	432	481	407	456	1775	1414	1021	1780	577	1483
160 1P-SP T	467	525	405	462	1859	1499	1021	1780	580	1518
85 2P-SP T	341	357	374	391	1463	1110	1021	1780	560	1417
95 2P-SP T	386	420	370	404	1580	1227	1021	1780	570	1476
115 2P-SP T	400	447	389	436	1673	1317	1021	1780	577	1470
125 2P-SP T	407	458	389	440	1694	1338	1021	1780	580	1477
140 2P-SP T	433	485	412	465	1796	1435	1021	1780	578	1478
160 2P-SP T	468	529	411	472	1880	1520	1021	1780	582	1513
85 3P-SP T	340	362	376	397	1474	1121	1021	1780	564	1415
95 3P-SP T	385	424	372	411	1592	1238	1021	1780	573	1473
115 3P-SP T	399	451	390	441	1681	1325	1021	1780	580	1468
125 3P-SP T	406	463	391	448	1707	1351	1021	1780	583	1474
140 3P-SP T	431	489	412	470	1802	1442	1021	1780	581	1477
160 3P-SP T	466	533	410	477	1886	1526	1021	1780	585	1511
85 1P-HP	326	340	167	181	983	1014	1021	1780	562	1736
95 1P-HP	371	402	164	194	1101	1132	1021	1780	576	1785
115 1P-HP	388	431	189	231	1206	1240	1021	1780	584	1745
125 1P-HP	395	442	188	236	1228	1262	1021	1780	587	1749
140 1P-HP	421	469	213	260	1325	1363	1021	1780	584	1731
160 1P-HP	457	513	211	267	1410	1447	1021	1780	588	1761
85 2P-HP	327	344	173	190	1004	1035	1021	1780	565	1723
95 2P-HP	373	407	170	204	1122	1153	1021	1780	579	1772
115 2P-HP	391	440	200	249	1246	1280	1021	1780	588	1724
125 2P-HP	397	451	199	253	1268	1302	1021	1780	591	1729
140 2P-HP	424	479	226	281	1372	1410	1021	1780	588	1709
160 2P-HP	460	523	224	287	1457	1494	1021	1780	592	1739
85 1P-HP T	340	354	372	385	1098	1452	1021	1780	558	1420
95 1P-HP T	386	417	368	399	1216	1569	1021	1780	568	1479
115 1P-HP T	403	446	393	436	1321	1677	1021	1780	574	1469
125 1P-HP T	410	457	393	440	1343	1699	1021	1780	577	1476
140 1P-HP T	436	484	417	464	1440	1801	1021	1780	576	1477
160 1P-HP T	471	528	415	471	1525	1885	1021	1780	579	1512
85 2P-HP T	342	359	377	395	1119	1473	1021	1780	560	1415
95 2P-HP T	387	421	374	408	1237	1590	1021	1780	570	1473
115 2P-HP T	406	455	404	453	1361	1717	1021	1780	578	1460
125 2P-HP T	412	466	404	457	1383	1739	1021	1780	580	1467
140 2P-HP T	439	494	430	485	1487	1848	1021	1780	579	1467
160 2P-HP T	474	538	428	492	1572	1932	1021	1780	582	1501

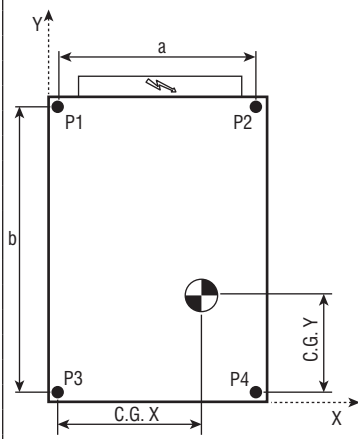

8 - Technical Data (continued)

AQVSH STAR	Weight distribution (kg)				Operating weight (kg)	Shipping weight (kg)	P1-P4 coordinates		CG coordinates	
	P1	P2	P3	P4			a (mm)	b (mm)	x (mm)	y (mm)
85	333	337	171	175	1016	996	1021	1780	552	1741
95	391	412	155	176	1134	1114	1021	1780	567	1828
115	408	440	175	207	1231	1207	1021	1780	575	1795
125	418	454	176	211	1258	1235	1021	1780	577	1801
140	445	480	198	234	1356	1329	1021	1780	575	1782
160	481	525	197	241	1442	1415	1021	1780	580	1808
85 1P-SP	350	353	177	180	1060	1029	1021	1780	551	1748
95 1P-SP	396	416	174	193	1178	1148	1021	1780	566	1794
115 1P-SP	413	444	194	225	1276	1243	1021	1780	573	1764
125 1P-SP	423	457	195	229	1304	1270	1021	1780	575	1770
140 1P-SP	450	484	218	253	1405	1367	1021	1780	573	1752
160 1P-SP	486	529	217	260	1491	1453	1021	1780	578	1779
85 2P-SP	351	357	182	187	1076	1045	1021	1780	554	1738
95 2P-SP	397	419	178	200	1194	1164	1021	1780	568	1784
115 2P-SP	414	448	199	233	1294	1260	1021	1780	575	1754
125 2P-SP	424	461	200	236	1322	1288	1021	1780	577	1761
140 2P-SP	451	489	224	262	1426	1388	1021	1780	576	1742
160 2P-SP	487	534	223	269	1512	1474	1021	1780	580	1769
85 3P-SP	350	361	183	194	1087	1057	1021	1780	559	1731
95 3P-SP	396	423	179	207	1206	1175	1021	1780	572	1777
115 3P-SP	413	454	201	241	1309	1275	1021	1780	580	1747
125 3P-SP	423	466	201	244	1335	1301	1021	1780	581	1754
140 3P-SP	449	493	223	267	1432	1394	1021	1780	579	1739
160 3P-SP	485	537	222	274	1519	1481	1021	1780	583	1767
85 1P-SP T	365	368	381	384	1498	1144	1021	1780	550	1438
95 1P-SP T	411	430	378	397	1616	1263	1021	1780	561	1494
115 1P-SP T	428	459	398	429	1714	1358	1021	1780	567	1489
125 1P-SP T	438	472	399	433	1742	1386	1021	1780	568	1498
140 1P-SP T	465	499	422	457	1843	1482	1021	1780	568	1499
160 1P-SP T	501	544	421	464	1929	1569	1021	1780	571	1532
85 2P-SP T	366	371	386	391	1514	1161	1021	1780	552	1435
95 2P-SP T	412	434	382	404	1632	1279	1021	1780	562	1490
115 2P-SP T	429	463	403	437	1732	1376	1021	1780	568	1485
125 2P-SP T	439	476	404	441	1759	1403	1021	1780	570	1494
140 2P-SP T	466	504	428	466	1864	1503	1021	1780	569	1494
160 2P-SP T	502	548	427	473	1950	1590	1021	1780	573	1527
85 3P-SP T	365	375	387	398	1525	1172	1021	1780	556	1432
95 3P-SP T	411	438	384	411	1643	1290	1021	1780	566	1487
115 3P-SP T	428	466	403	442	1740	1384	1021	1780	571	1483
125 3P-SP T	438	481	405	448	1772	1416	1021	1780	573	1491
140 3P-SP T	464	507	428	471	1870	1510	1021	1780	572	1493
160 3P-SP T	500	552	426	478	1956	1596	1021	1780	576	1525
85 1P-HP	351	353	179	182	1065	1034	1021	1780	551	1745
95 1P-HP	397	416	175	195	1183	1152	1021	1780	565	1791
115 1P-HP	417	447	203	232	1299	1265	1021	1780	572	1752
125 1P-HP	427	460	203	236	1326	1293	1021	1780	574	1758
140 1P-HP	454	487	228	261	1431	1393	1021	1780	572	1739
160 1P-HP	490	532	227	268	1517	1479	1021	1780	576	1767
85 2P-HP	352	358	185	191	1086	1055	1021	1780	554	1732
95 2P-HP	398	421	181	204	1204	1173	1021	1780	568	1778
115 2P-HP	419	456	214	250	1339	1305	1021	1780	576	1731
125 2P-HP	430	469	214	254	1366	1333	1021	1780	578	1738
140 2P-HP	457	498	241	282	1478	1440	1021	1780	576	1718
160 2P-HP	493	542	240	289	1564	1526	1021	1780	580	1746
85 1P-HP T	366	368	383	386	1503	1149	1021	1780	550	1437
95 1P-HP T	411	431	380	399	1621	1268	1021	1780	561	1493
115 1P-HP T	432	461	407	437	1736	1380	1021	1780	566	1483
125 1P-HP T	442	475	407	440	1764	1408	1021	1780	568	1493
140 1P-HP T	469	502	432	465	1869	1508	1021	1780	566	1493
160 1P-HP T	505	546	431	472	1955	1595	1021	1780	570	1525
85 2P-HP T	367	373	389	395	1524	1170	1021	1780	552	1432
95 2P-HP T	413	435	385	408	1642	1289	1021	1780	563	1488
115 2P-HP T	434	470	418	454	1776	1420	1021	1780	569	1474
125 2P-HP T	444	483	419	458	1804	1448	1021	1780	571	1483
140 2P-HP T	472	512	445	486	1916	1555	1021	1780	570	1483
160 2P-HP T	508	557	444	493	2002	1642	1021	1780	573	1515

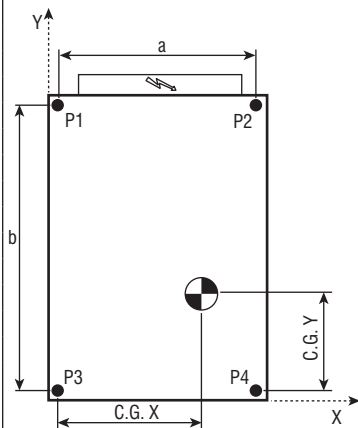

8 - Technical Data (continued)

8.6 Dimensional drawings - AQVSL/AQVSH STAR 85 to 160

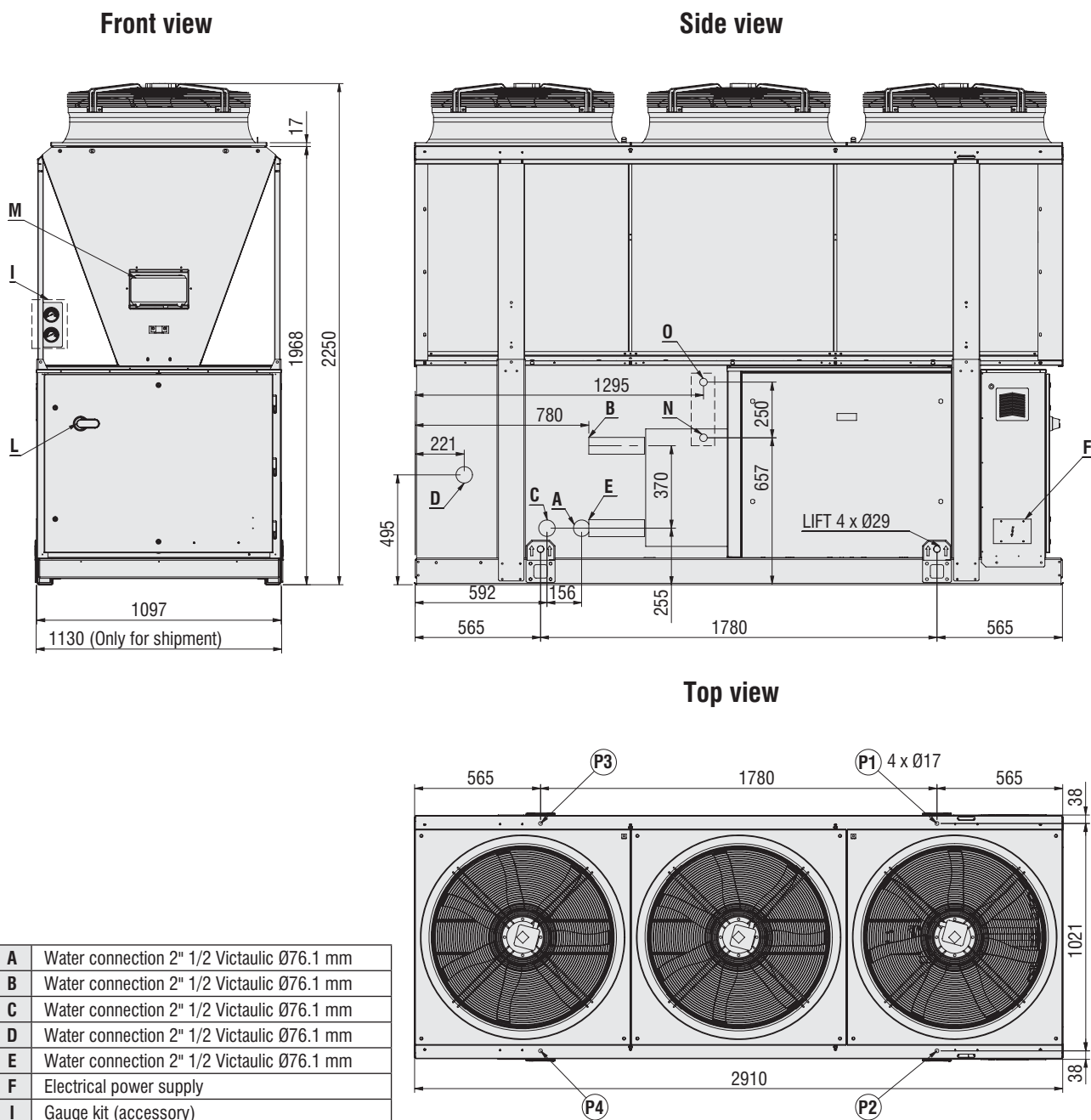

A	Water connection 2" 1/2 Victaulic Ø76.1 mm
B	Water connection 2" 1/2 Victaulic Ø76.1 mm
C	Water connection 2" 1/2 Victaulic Ø76.1 mm
D	Water connection 2" 1/2 Victaulic Ø76.1 mm
E	Water connection 2" 1/2 Victaulic Ø76.1 mm
F	Electrical power supply
I	Gauge kit (accessory)
L	Main switch
M	Control keypad / Display
N	Optional desuperheater water inlet Ø 1" Gas male
O	Optional desuperheater water outlet Ø 1" Gas male
P1	Anti-vibration mount position
P2	Anti-vibration mount position
P3	Anti-vibration mount position
P4	Anti-vibration mount position

Hydraulic option	Water in	Water out
STD	B	E
1P/2P/3P	A	C
1PT/2PT/3PT	A	D

8 - Technical Data (continued)

Fan position AQVSL/AQVSH STAR 85-115-125-140

Top view

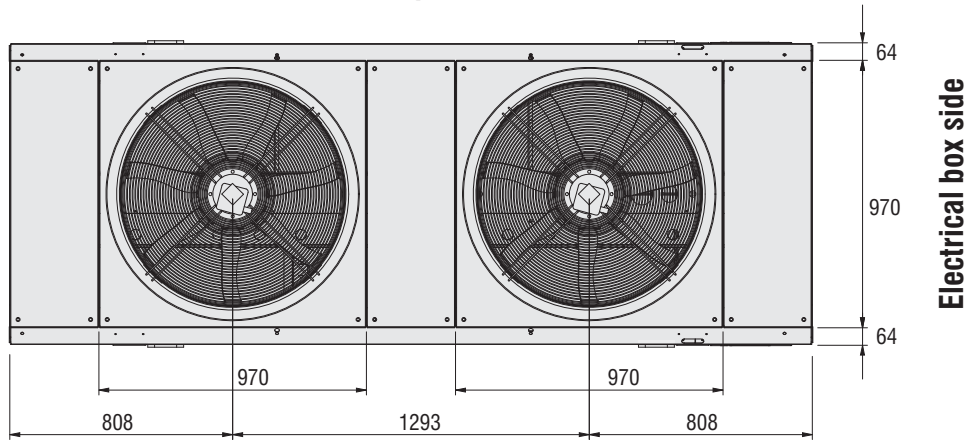

Fan position AQVSL/AQVSH STAR 95-160

Top view

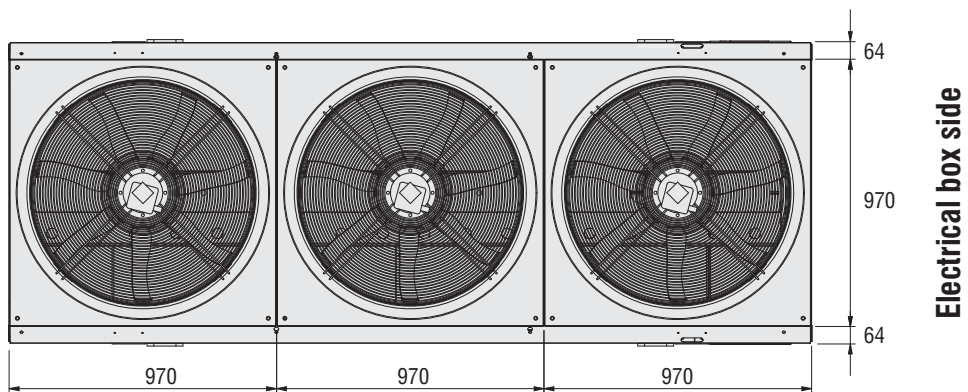

8 - Technical Data (continued)

8.7 Unit clearances (in mm) - AQVSL/AQVSH STAR 85 to 160 - R410A

Installation of single units

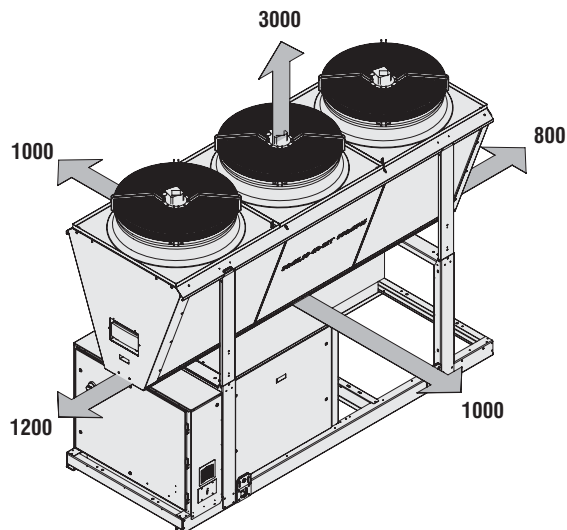

Installation of several units

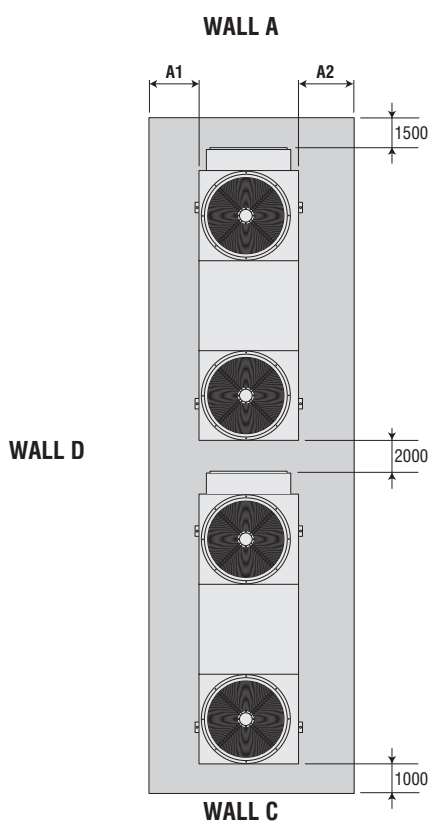

ARRANGEMENT 1

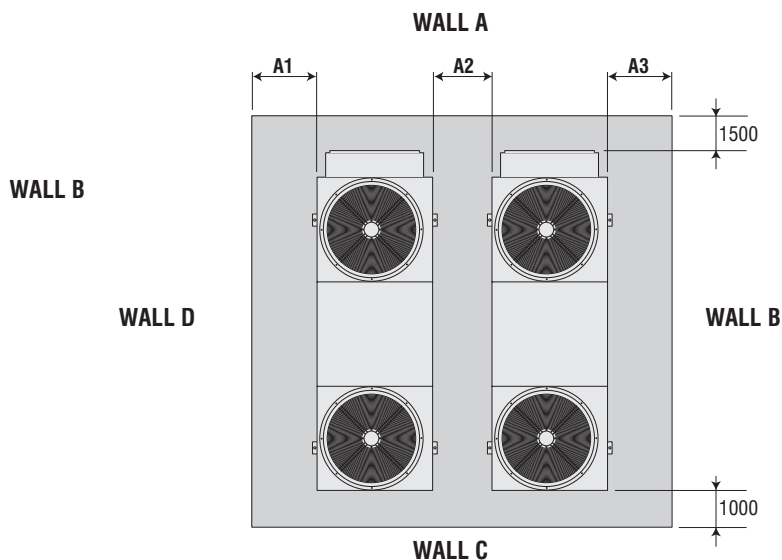

ARRANGEMENT 2

	A and C grille B and D full			A and B full C and D full			A and C full B and D grille			A and B grille C and D full			A and D grille B and C full		
	A1	A2	A3	A1	A2	A3	A1	A2	A3	A1	A2	A3	A1	A2	A3
ARRANGEMENT 1	1000	1000		1000	1000		800	800		1000	800		800	1000	
ARRANGEMENT 2	1000	1500	1000	1000	2000	1000	800	2000	800	1000	1500	800	800	1500	1000

No more than one wall can be higher than the unit.
The area enclosed by the wall must be kept clear of all obstructions that would impede air flow to the unit. Dimensions in mm.

9 - Maintenance

Carefully read the “Safety” section of this manual before carrying out any maintenance operations.

	<p>Do not discharge the refrigerant into the atmosphere while the refrigeration circuits are being drained. Use appropriate recovery equipment.</p> <p>When the recovered refrigerant cannot be re-used, return it to the manufacturer.</p>
---	---

	<p>Do not throw away the waste oil of the compressor, because it contains refrigerant in solution.</p> <p>The waste oil must be returned to the manufacturer.</p>
---	---

Unless otherwise specified, the operations described below may be carried out only by a trained maintenance operator.

9.1 General requirements

Units have been designed for continuous operation, providing that they are subjected to regular maintenance, within the limits specified in this manual. Each unit must be serviced according to the programme by the User/Customer, and must be inspected at regular intervals by the personnel of one authorised Service Centers.

It is the responsibility of the User to meet these maintenance requirements and/or to enter into an agreement with one of authorised Service Centers, so as to properly safeguard the operation of the appliance.

During the warranty period, in case of damage or failures caused by improper maintenance, manufacturer will not refund the costs incurred to repair the appliance in its original state.

The provisions of this section apply only to standard units; according to the order requirements, other documentation may be added, concerning any modifications or supplementary accessories.

9.2 Planned maintenance

Maintenance inspections must be carried out according to the program below, by a qualified person.

As a general rule, units cannot be repaired directly by the user, who shall not try to service or repair any failures or anomalies identified during daily inspections. If you are in doubt, please contact authorised Service Centre.

Operations	Daily	Weekly	Monthly	Beginning of season	End of season
Check the temperature of the leaving fluid	●				
Check the pressure drops in the heat exchanger		●			
Check for electric absorption		●			
Check suction pressure and temperature		●			
Check delivery pressure and temperature		●			
Check the oil level in the compressor		●			
Check that there are no gas bubbles in the liquid line		●			
Check that the fins of the external coil are clean (if any)			●		
Check the operation of the oil heaters			●		
Check the remote control switches			●		
Check the operation of the LP pressure switch				●	
Check the operation of the HP pressure switch				●	
Check the insulation of the heat exchanger				●	
Check that terminals are tightened				●	
Check that the terminals' screws are tightened				●	
Clean the exterior of the unit with water and soap				●	
Check the density of the antifreeze (if any)				●	●
Check the operation of the flow switches				●	
Check the operation of the solenoid valve				●	●

9 - Maintenance (continued)

9.3 Refrigerant charge

Do not inject refrigerant liquid into the LP side of the circuit. Be very careful, and charge the circuit properly. If the charge is insufficient, the efficiency of the unit will be lower than expected. (In the worst of cases the LP transducer may stop the unit.)

In the presence of an excess charge, the condensing pressure will rise (in the worst of cases, the HP pressure switch may be activated, resulting in the stop of the equipment), and the consumption will increase as well.

It is strictly forbidden to use the compressor as a vacuum pump to drain the plant.

Fill the refrigeration circuit after it has been drained for maintenance purposes (leaks, replacement of the compressor etc.). The amount of the charge is indicated on the plate affixed to the unit.

Before refilling, it is important to drain and de-hydrate the circuit, thus obtaining a minimum abs. pressure value of 50 Pa.

Inject the refrigerant fluid before removing the vacuum, then fill the circuit up to 90% of the total gas requirement (in liquid form). The appliance must be filled through the filling valve on the liquid line, on the outlet side of the condenser.

It is recommended to connect the refrigerant cylinder to the filling valve on the liquid line, and to arrange it in such a way as to inject only liquid refrigerant.

9.4 Compressor

Compressors are delivered with the necessary charge of lubricating oil. During normal operation, this charge is sufficient for the whole life of the unit, providing that the efficiency of the refrigeration circuit is satisfactory and if it has not been overhauled.

If the compressor needs to be replaced (following a mechanical failure or if burnt), contact one of authorised Service Centers.

Compressors use polyester oil. During maintenance operations on the compressor, or if you have to open the refrigerant circuit in any point, remember that this type of oil is highly hygroscopic, and accordingly it is important that it is not left exposed to the weather for prolonged periods, as this would require the replacement of the oil.

In a few cases, the polyester oil may be present also in R22 units (a refrigerant that can be used also in extra UE countries).

9.5 Condenser

The condenser's coils consist of copper pipes and aluminium fins. In the presence of leaks caused by any damage or shock, the coils shall be repaired or replaced by one of authorised Service Centers. To ensure the effective and correct operation of the condenser coils, it is important to keep the condenser's surface perfectly clean, and to check that there is no foreign matter, such as leaves, wires, insects, waste etc. If the coil becomes dirty, there is an increase in the absorption of electric energy. Furthermore, the maximum pressure alarm may be activated and may halt the unit.

Be careful not to damage the aluminium fins during cleaning.

The condenser must be cleaned with a LP compressed air jet, parallel to the aluminium fins, in the direction opposite to the air circulation.

To clean the coil you can use also a vacuum cleaner, or a jet of water and soap.

9.6 Fans

The fans of the condenser, of axial type, are complete with impeller with aerodynamic profile blades and a cylindrical nozzle. The motor's bearings are lubricated forever.

9.7 Dehydrating filter

The refrigeration circuits are provided with dehydrating filters.

The filter clogging is marked by the presence of air bubbles in the sight glass, or by the difference between the temperatures measured downstream from and upstream of the drying filter. If, once the cartridge has been cleaned, there are still some air bubbles, the appliance has lost a part of the refrigerant charge in one or more points, that must be identified and serviced.

9.8 Sight glass

The sight glass is used for inspecting the refrigerant flow and the humidity % of the refrigerant. The presence of bubbles indicates that the dehydrating filter is clogged or the charge insufficient.

A colour indicator is positioned inside the sight glass. If you compare the colour of the indicator to the scale on the ring of the sight glass, you can calculate the percentage of humidity of the refrigerant. If it is excessive, replace the filter's cartridge, operate the appliance for 1 day and then check the humidity % again. When the humidity % is within the pre-determined range, no other operations are required. If the humidity % is still too high, replace the dehydrating filter again, start the unit and operate it for another day.

9 - Maintenance (continued)

9.9 Mechanical expansion valve

The circuit of the unit is equipped with a mechanical expansion valve, with external equalizer

The valve is factory calibrated for an overheating of 5 °C.

Procedure to check for overheating :

- Measure the suction pressure with the pressure gauges on the board of the unit or using a pressure gauge connected to the service valve on the suction side.
- From the pressure gauge's temperature scale, measure the saturated suction temperature (Tsa) which corresponds to the pressure value.
- Using a contact pressure gauge affixed to the outlet fitting of the gas of the evaporator, measure the actual temperature (Tse).

Overheating calculation (S):

$$S = Tse - Tsa$$

Overheating is regulated through the expansion valve.

Make the adjusting screw follow a complete turn, and operate the appliance for five minutes.

Check again and, if necessary, repeat the regulation.

If the expansion valve cannot be regulated, it is probably broken, and shall be replaced. The replacement must be carried out by a Service Centre.

9.10 Evaporator

Check at regular intervals that the water side of the heat exchanger is perfectly clean. To do this, measure the pressure drop, water side (see Section 8) or measure the temperature of the liquid leaving and entering the heat exchanger, and compare it to the evaporation temperature.

To obtain an effective heat exchange, the difference between the temperature of the leaving water and the saturated evaporating temperature must be in the 2 - 4°C range. A greater difference would indicate a low efficiency of the heat exchanger (i.e. the heat exchanger is dirty).

In this case, the heat exchanger must be subjected to chemical cleaning, an operation that shall be carried out by authorised engineers.

For other maintenance operations (extraordinary overhauling, replacement of the heat exchanger etc.), contact an authorised Service Centre.

10 - Troubleshooting

The table below lists the anomalies of operation of the unit, the relevant causes and the corrective measures. For anomalies of any other type or not listed, contact one of authorised Service Centre for technical assistance.

Anomaly	Cause	Operation
The unit continues to work, but without cooling	Insufficient charge of refrigerant.	Refill.
	The dehydrating filter is clogged.	Replace.
Ice on the suction line	Wrong calibration of overheating.	Increase overheating.
		Check the charge.
Excessive noise	Vibration of lines.	Check the clamping brackets, if any.
	Whistler emitted by the thermostatic expansion valve.	Refill.
		Check the dehydrating filter.
	Noisy compressor.	Seized bearings; replace the compressor.
Check that the compressor's locknuts are tightened.		
Low oil level in the compressor	One or more gas or oil leaks in the circuit.	Identify and remove leaks.
	Mechanical failure of the compressor.	Request the intervention of a Service Centre.
	Anomaly of the oil heater of the compressor's base.	Check the electric circuit and the resistor of the heater of the motor base, and replace defective components.
One or both compressors are not working	Breaking of the electric circuit.	Check the electric circuit and detect any ground dispersions and short circuits. Check fuses.
	Intervention of the HP pressure switch.	Reset the pressure switch and the control panel and restart the appliance. Identify and remove the cause that enabled the pressure switch.
	The fuse of the control circuit is broken.	Check for ground dispersions and short circuits. Replace fuses.
	Loosened terminals.	Check and tighten.
	Halt caused by thermal overload of the electric circuit.	Check the operation of check and safety devices. Identify and remove the cause.
	Wrong wiring.	Check wiring of check and safety devices.
	The line voltage is too low.	Check voltage. If problems regard the system, solve them. If they are caused by the distribution network, inform the Energy Distributor.
	Short-circuit of the compressor's motor.	Check the continuity of the winding.
Seized compressor.	Replace the compressor.	
Activation of the LP alarm, stop of the unit	Gas leak.	Identify and remove the leak.
	Insufficient charge.	Refill.
	Failure of the pressure switch.	Replace the pressure switch.
Activation of the HP alarm, stop of the unit	Failure of the pressure switch.	Check the operation of the pressure switch, replace it if defective.
	The delivery valve is partially closed.	Open the valve and replace it, if faulty.
	Substances with condensable gases in the circuit.	Drain the circuit.
	The fan of the condenser is stopped.	Check cables and motor. If defective, repair or replace.
The liquid line is too hot	Insufficient charge.	Identify and remove the cause of the loss of charge and refill.
Frosting of the liquid line	The valve of the liquid line is partially closed.	Check that valves are open.
	The liquid filter is clogged.	Replace the cartridge or the filter.

11 - Spare Parts

11.1 Spare part list

The table below shows the list of spare parts recommended during the first two years of operation.

Component	Number
Fan	1
Flow switch	1
High pressure transducer	1
Low pressure transducer	1
Expansion valve	1
Gas filter	1
4 way valve	1
Electronic main board	1
Auxiliary circuit transformer	1
Compressor contactor	2
Pump contactor	1
Water sensor	4
Air sensor	1
Auxiliary contact	4
Driver EEV	1
Fuses	4

11.2 Oil for compressors

The compressors are lubricated with polyester oil (P.O.E.).

11.3 Wiring diagrams

The wiring diagrams are installed inside the doors of the electrical panels of the unit. Any request for wiring diagrams shall be forwarded to manufacturer's Service Centre.

12 - Dismantling, Demolition and Scrapping



During the draining of the refrigeration circuits, do not let the refrigerant overflow in the surrounding atmosphere.

The circuit must be drained using suitable recovery equipment.



Do not disperse the waste oil of the compressors in the environment, since it contains some dissolved refrigerant.

For the disposal, contact the competent authority for information.

Unless otherwise specified, the maintenance operations listed below may be carried out by any trained maintenance operator.

12.1 Generalities

Open each line that supplies the unit, including the ones of control circuits. Make sure that all disconnecting switches are secured in the off position. The power cables can be disconnected and disassembled. Refer to Chapter 4 for the position of connection points.

Remove all the refrigerant from the refrigeration circuits of the unit and store it in suitable containers, using a recovery unit. If its characteristics have remained the same, the refrigerant can be used again. Contact the competent authority to obtain information about disposal. In **NO** event shall the refrigerant be discharged into the atmosphere. The oil in each refrigeration circuit must be drained and collected into a suitable container; then it shall be disposed of in conformity with local regulations that apply to the disposal of waste lubricants. Any oil spillage must be recovered and disposed of in like manner.

Isolate the unit's heat exchangers from the external hydraulic circuits and drain the heat exchange sections of the plant.



If no shutoff valves have been provided, it may be necessary to drain the whole plant.

If a glycoled solution or a similar fluid has been used in the hydraulic circuits, or if chemical additives have been added to the circulating water, the circulating fluid MUST be drained in a proper way.

For NO reason shall a circuit containing glycoled water or a similar solution be discharged directly into the drains or surface waters.

After draining operations, the piping of the hydraulic networks can be disconnected and disassembled.

Once they have been disconnected as specified, the packaged units can be disassembled in a single piece. First of all, disassemble the anchoring screws and then lift the unit from the position of installation, and hook it to the lifting points provided, using suitable lifting equipment.

To this end, refer to Chapter 4 for the installation of these appliances, to Chapter 8 for their weights and Chapter 3 for handling.

The units that, once disconnected, cannot be removed in a single piece, must be dismantled on site; in this case, be very careful with the weight and handling of every single component.

It is always advisable to dismantle the units following the installation steps, but in reverse.



Some residues of oil, glycoled water or similar solutions may remain in certain parts of the unit. These residues must be recovered and disposed of according to the procedures specified above.

It is very important to ensure that, while a component of the unit is being removed, all the others are properly supported.



Use only lifting means of adequate capacity.

Once disassembled, the components of the unit can be disposed of in conformity with current regulations.

Note

A large grid of 20 columns and 25 rows of dotted lines, intended for writing notes. The grid is composed of small squares formed by dotted lines, providing a guide for handwriting.

AIRWELL ITALIA

Via XXV Aprile, 29
20030 Barlassina (MI)
Italy

☎ : +39 0362 680.1
☎ : +39 0392 680.281



As part of our ongoing product improvement programme, our products are subject to change without prior notice. Non contractual photos.

Dans un souci d'amélioration constante, nos produits peuvent être modifiés sans préavis. Photos non contractuelles.

In dem Bemühen um ständige Verbesserung können unsere Erzeugnisse ohne vorherige Ankündigung geändert werden. Fotos nicht vertraglich bindend.

A causa della politica di continua miglioria posta in atto dal costruttore, questi prodotti sono soggetti a modifiche senza alcun obbligo di preavviso. Le foto pubblicate non danno luogo ad alcun vincolo contrattuale.

Con objeto de mejorar constantemente, nuestros productos pueden ser modificados sin previo aviso. Fotos no contractuales.

