

# Aqu@Logic

Air Cooled Condensing Units

Models AQC 40 to 75



43.2 to 84.5 kW



## Outstanding Strength Points

- R410A Refrigerant.
- New simpler refrigerant circuit layout.
- Low sound level for BLN unit, very low sound level for ELN unit.
- Great accessibility to internal components for service operations.
- New display on external panel allows the complete control of the unit.
- More assembling quality.
- Construction easier.
- Operating limit of the unit stored in the flash memory of the control logic.
- Wide operating limits.
- High temperature operating limits.
- Less noisy compared to the unit with R407C.
- Less number of screws and piece of sheet metal.
- Component standardization (symmetric sheet metal, only 2 kinds of screws ...).
- New gauge kit can be fitted directly inside the units and not outside. This gauge kit is cheaper than R407C one and it is common for the whole range.
- Fan speed control for low ambient operation in cooling mode down to -18 °C.
- ModBus interface.
- Phase sequence monitor supplied as standard.
- User-friendly microprocessor control.
- For safety during service operations, special valves dedicated to R410A are available on the refrigerant system. These valves, of 5/16" flare SAE type, are mounted on the liquid line inside and on the lateral panel of the unit. This facilitates the access to the high and low side of the refrigerant circuit in order to do pressure measurement.
- Rubber pad supplied as standard.
- New anti-vibration kit, easier to be installed (same spring for every corner).
- Special Inverter Fan (SIF) version suitable for a widening of operating conditions, like ducted installation where high static pressure is needed or high ambient air temperature installation. Fan speed will be regulated by condensing pressure.
- Smaller footprint. The units are 100 mm thinner in order to simplify the transport operation.
- Extra low noise version now available.
- Smart hook in the electrical panel that keeps in position the closing panel while the operator is working on the electrical box.
- Refrigerant circuit completely enclosed in a separated box in order to reduce the noise, not only of the compressors but also of the whole circuit.

## Specifications

### General

The new **AQC** air cooled condensing units have been designed and optimized to operate with **R410A** refrigerant fluid.

The AQC range consists of **6 sizes (40, 45, 50, 60, 65 & 75)** and covers a nominal cooling capacity range from **43.2 to 84.5 kW**.

All units are equipped **two scroll compressors fitted in tandem** for adapting to partial system loads.

The general operation status of the machine is continuously under the control of a **microprocessor based controller**.

**A fan speed controller** can be supplied loose as field-installed accessory to authorize the unit to operate in cooling mode at low ambient temperature.

The AQC units can be supplied in **3 versions** :

- **Base Low Noise (BLN)** : This version is equipped with delta connected fan motors.
- **Extra Low Noise (ELN)** : This version is equipped with star connected fan motors which allow the unit to operate with a very low rpm. Compressor sound proof jackets are also supplied as standard on this version.
- **Special Inverter Fan (SIF)** : This version is equipped with inverter fan that allows the unit to be used as ducted or high ambient temperature unit thanks to the high static pressure and the high air flow provided by inverter fan.

### Cabinet and structure

The cabinet and structure are made of heavy gauge galvanized steel. **All galvanized steel components are individually painted** by a special painting process before the assembly of the unit. This painting system performs a homogeneous protection to the corrosion.

The painting is a polyester powder based type, coloured in **RAL 9001**.

The units are suitable for outdoor installation, directly on the building roof or at the ground level.

### Compressors

Each unit is equipped with **two scroll** compressors fitted on a rail and assembled together to form **tandem** compressors. The compressors are then mounted on rubber pads in order to eliminate noise and vibration transmissions.

The compressor motors have a direct start-up. Each motor is cooled by the refrigerant gas and is equipped with an overload protection.

A soft start system can be supplied as optional, whereas a **phase sequence monitor** is supplied as standard.

### Condenser

The condenser is a finned coil constructed with seamless copper tubes mechanically expanded into aluminium fins.

The condenser coil is composed of **internally smooth tubes with louvered fins** to improve the heat transfer.

The air cooled condenser is supplied with a protective grille as standard.

## Specifications (continued)

### Condenser fans and motors

Each unit has one axial fan, of fixed speed type with diameter of 800 mm. According to the version, the fan is cabled in order to have **high speed** (700 to 900 rpm) for BLN version and **low speed** (530 to 680 rpm) to reduce the sound level for ELN version.

The fan motor has IP54 grade and is equipped with a thermal overload protection.

A pressure actuated fan speed controller can be supplied as field-installed accessory or factory-fitted option. It allows the unit to operate in cooling mode at ambient temperature down to -18 °C because it regulates the fan speed in order to maintain constant the condensing temperature.

On the SIF version, the fan is controlled by a 0-10 V DC signal that regulates the speed from 0 to 1110 rpm. This special fan allows the unit to be used in two applications :

- **High ambient temperature** : The fan provides high air flow at maximum speed in order to keep a low condensing temperature while operating at high air temperature.
- **Ducted installation** : The fan provides high static pressure in order to allow the unit to be ducted.

The SIF fan can also be evolved in order to avoid the use of a fan speed controller.

All types of fans are fitted with a protective grille on top.

### Refrigerant circuit

All units have one refrigerant circuit consisting of scroll tandem compressors, condenser coil, as well as safety and control devices, such as : high pressure switch, high/low pressure transducers and PED safety valve.

The refrigerant circuit is also fitted with suction and liquid line shut-off valves to allow the connection of the unit to the external evaporator.

A gauge kit can be supplied as a common accessory for all sizes to be installed inside the unit in order to read the high and low pressure values.

All refrigerant components are shown in the functional diagrams illustrated in the next pages, section "Refrigerant flow diagrams".

### Control panel

The units are fitted with an external control panel that displays the operating parameters and alarms. This control panel is **accessible from outside** without removing any parts because it is placed on an external panel. A Plexiglas cover protects the control from external agent.

The AQC units are equipped with the "CHILLER CONTROL" system that has the main features as stated below :

- microprocessor control,
- user-friendly keyboard,
- access code to enter the Manufacturer's Level,
- access code to enter the Assistance Level,
- Alarm and LED,
- backlit LCD,

- pump-down logic (start-stop),
- rotation of the compressor operation,
- oil return function,
- night mode (or Low Noise) control,
- counting of the pump/compressor's hours of operation,
- display of discharge and suction pressure values,
- display of temperature sensor,
- history of stored alarms (option),
- programming of different setpoints with 4 ranges of time/setpoint.

The following accessories can be also connected :

- serial communication RS485 card; to connect the "Chiller control" to a BMS network,
- remote display terminal,
- wire remote control.

The control system consists of a microprocessor card which is fully programmed by default for the control of a condensing unit, and a keyboard and display terminal.

The figure below shows the terminal with the front door open.

It is provided with a LCD 4 lines x 20 columns, keyboard and microprocessor-controlled LED's, so as to allow the programming of the control parameters (setpoint, differential bands, alarm thresholds) and the main operations to be carried out by the user.

#### Keyboard and display terminal

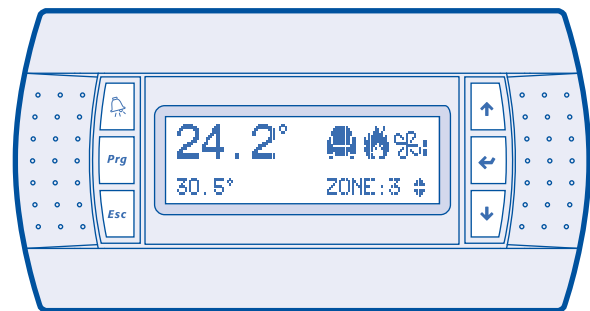

The terminal makes it possible to carry out the following operations :

- the initial configuration of the machine,
- the change of all the main operating parameters,
- the display of the detected alarms,
- the display of all measured quantities.

The terminal and the card are connected by a 6-way phone cable.

## Specifications (continued)

### Control and safety devices

Each unit is complete with the following safety and control devices :

#### Safety :

- Fan motor overload protection,
- Compressor motor overload protection,
- High pressure switch,
- High and low pressure transducers,
- Crankcase oil electric heater,
- 45 bar refrigerant safety valve,

#### Control :

- Discharge temperature sensor,
- Air temperature sensor,
- Suction and discharge pressure transducers.

### Conformity with standards

All AQC units are in compliance with the following standards :

- ✓ Machine Directive : 2006/42/EC
- ✓ Low Voltage Directive : 2006/95/EC
- ✓ Electromagnetic Compatibility Directive : 2004/108/EC
- ✓ Pressure Equipment Directive : 97/23/EC

### Factory-installed options

- Blue fin coil,
- Coil with "Fin Guard Silver" treatment,
- Coil with black epoxy treatment,
- Soft starter,
- Power supply without neutral kit,
- Automatic circuit breaker,
- Compressor overload protection,
- Fan speed control kit,

### Field-installed accessories

- Antivibration kit,
- Fan speed control kit,
- Gauge kit,
- Remote On/Off control,
- ModBus protocol kit for BMS,
- Power factor correction capacitors,
- Sequencer for up to 4 unit installation,
- Compressor soundproof jackets (this option is standard on ELN version).

# Refrigerant Flow Diagram - AQC 40 to 75 - R410A

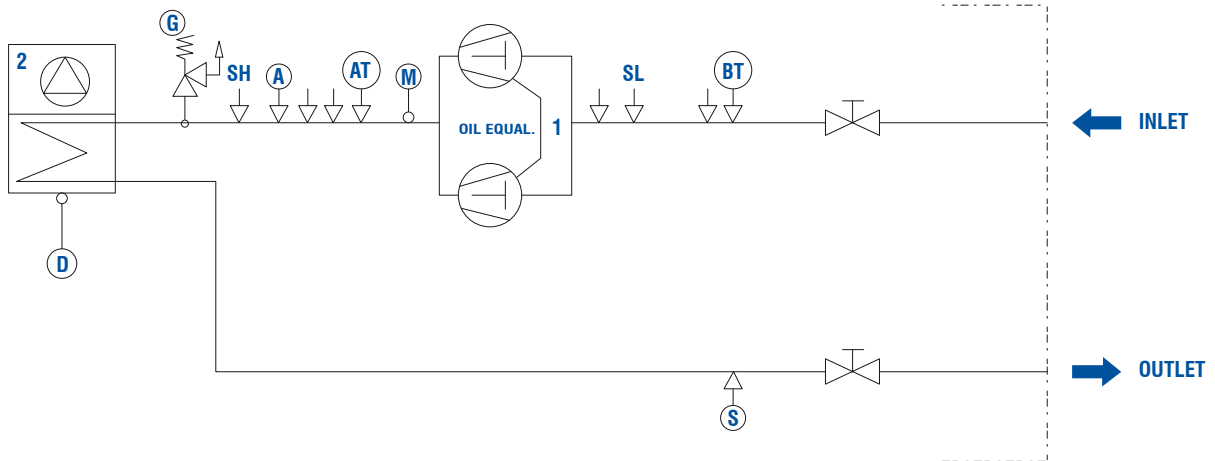

## COMPONENTS

- |          |                               |
|----------|-------------------------------|
| <b>1</b> | Compressor tandem scroll type |
| <b>2</b> | Air cooled condenser          |

## SAFETY / CONTROL DEVICES

<b>A</b>	High pressure switch (40.5 bar)	<b>G</b>	Safety valve (45 bar)
<b>AT</b>	High pressure transducer	↓	Pipe connection with Schrader valve 1/4" SAE
<b>BT</b>	Low pressure transducer		
<b>D</b>	Air temperature sensor	.....	Unit side
<b>M</b>	Discharge temperature sensor	-----	Optional
<b>S</b>	5/16" SAE Schrader valve (charging point)	○	Probes
<b>SH</b>	5/16" SAE high pressure Schrader valve		
<b>SL</b>	5/16" SAE low pressure Schrader valve		

# Operating Limits

## Operating limits - AQC 40 to 75 - R410A - BLN Version

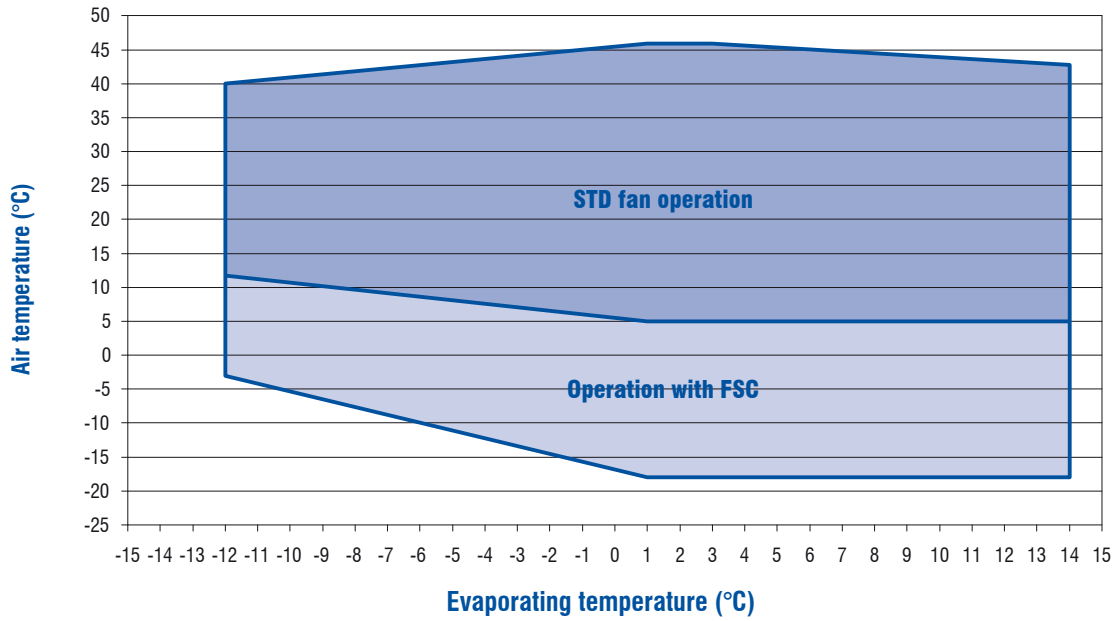

**Note :** Operating limits are referred to full load (2 compressors running).

## Operating limits - AQC 40 to 75 - R410A - ELN Version

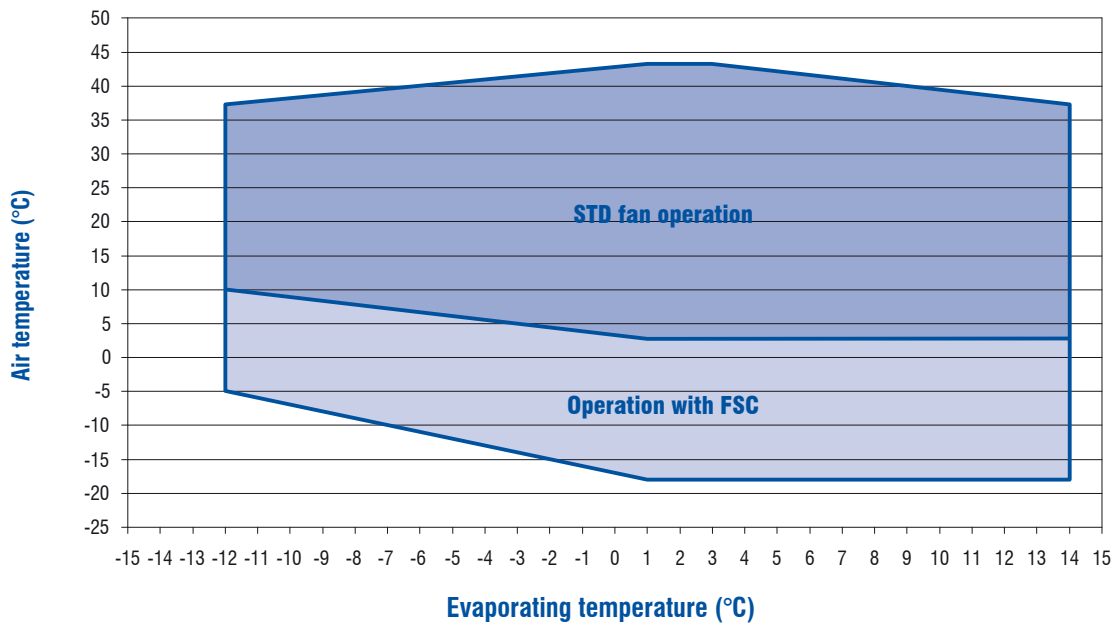

**Note :** Operating limits are referred to full load (2 compressors running).

## Operating Limits (continued)

### Operating limits - AQC 40 to 75 - R410A - SIF Version

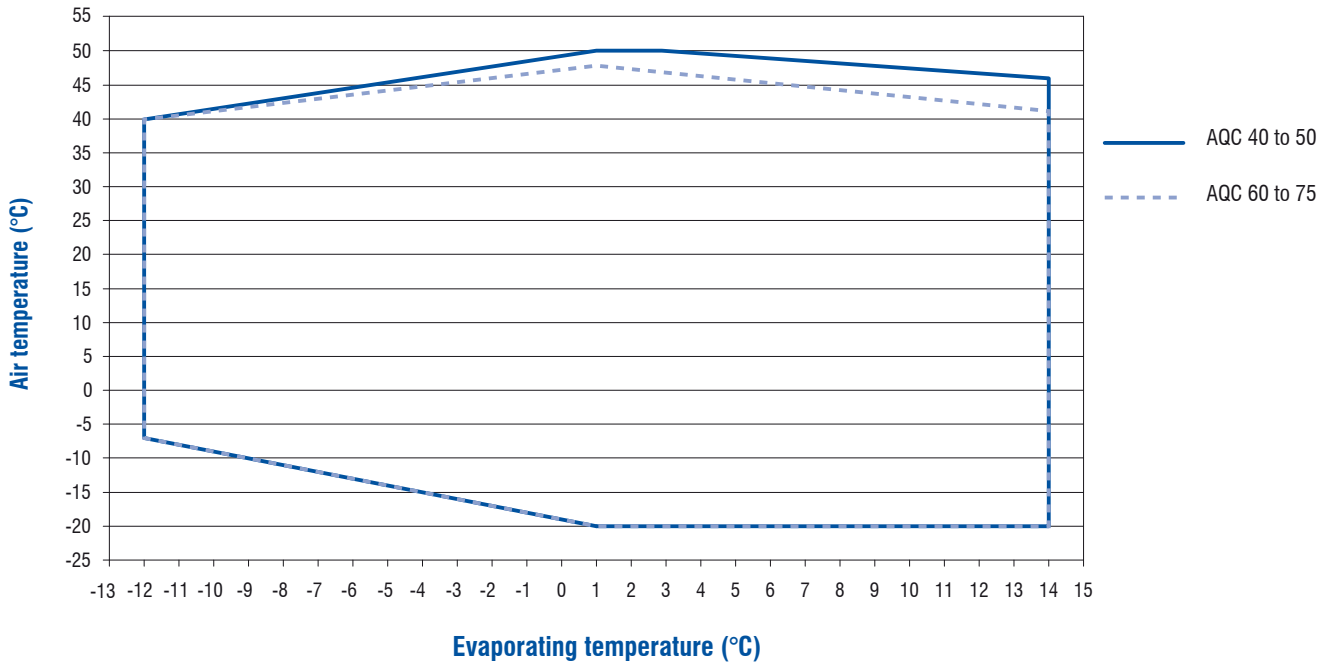

**Note :** Operating limits are referred to full load (2 compressors running).

## Correction Factors

### Fouling factors - Condenser

Fouling factor (m <sup>2</sup> .°C/kW)	Cooling capacity factor	Power input factor
0.044	1.000	1.000
0.088	0.987	1.023
0.176	0.955	1.068
0.352	0.910	1.135

### Altitude factors

Altitude (m)	Cooling capacity factor	Power input factor
0	1.000	1.000
600	0.987	1.010
1200	0.973	1.020
1800	0.958	1.030
2400	0.943	1.040

## Physical Data - AQC 40 to 75 - R410A - BLN Version

AQC BLN		40	45	50	60	65	75
Cooling Capacity - (OAT 35 [°C], ET 7 [°C])	kW	43.2	48.8	56.9	67.4	73.8	84.5
Input Power (Compressor) - (OAT 35 [°C], ET 7 [°C])	kW	13.0	15.3	17.8	18.7	21.6	26.3
Number of Refrigerant Circuits		1	1	1	1	1	1
Part Load Steps	%	0-50-100	0-50-100	0-50-100	0-44-56-100	0-50-100	0-50-100
Power Supply		400V/3/50Hz	400V/3/50Hz	400V/3/50Hz	400V/3/50Hz	400V/3/50Hz	400V/3/50Hz
Startup Type		Direct	Direct	Direct	Direct	Direct	Direct
Maximum Current (FLA)	A	Refer to electrical data					
Startup Current (LRA)	A						
<b>REFRIGERANT</b>							
Type		R410A					
<b>COMPRESSOR</b>							
Number		2	2	2	2	2	2
Type		Scroll	Scroll	Scroll	Scroll	Scroll	Scroll
Crankcase Heater	W	90	90	90	90	90	90
<b>COIL</b>							
Number		1	1	1	1	1	1
Frontal Surface	l x a	2160 x 1200	2160 x 1200	2160 x 1200	2650 x 1200	2650 x 1200	2650 x 1200
Row		2	2	3	3	3	3
<b>FANS</b>							
Number		1	1	1	1	1	1
Air Flow Rate	m <sup>3</sup> /h	14000	14000	13200	21100	21100	21100
Speed	rpm	680	680	680	900	900	900
Input Power	kW	0.98	0.98	0.98	2.00	2.00	2.00
<b>REFRIGERANT CONNECTIONS</b>							
Type		To be brazed					
Inlet Diameter	inch	5/8"	5/8"	5/8"	7/8"	7/8"	7/8"
Outlet Diameter	inch	1"3/8	1"3/8	1"3/8	1"3/8	1"3/8	1"3/8
<b>WEIGHT</b>							
Shipping Weight	kg	391	399	422	456	466	469
Operating Weight	kg	391	399	422	456	466	469
<b>DIMENSIONS</b>							
Length	mm	1750	1750	1750	2200	2200	2200
Width	mm	1100	1100	1100	1100	1100	1100
Height	mm	1580	1580	1580	1580	1580	1580
<b>ACOUSTIC DATA (NORMAL MODE)</b>							
Sound Power Level	dB(A)	80.5	81.0	81.0	85.5	85.6	85.8
Sound Pressure Level (1)	dB(A)	48.9	49.4	49.4	53.8	53.9	54.1

(1) Sound pressure calculated at 10 m.

## Physical Data - AQC 40 to 75 - R410A - ELN Version

AQC ELN		40	45	50	60	65	75
Cooling Capacity - (OAT 35 [°C], ET 7 [°C])	kW	41.6	46.7	54.0	64.9	70.7	80.6
Input Power (Compressor) - (OAT 35 [°C], ET 7 [°C])	kW	13.7	16.3	19.1	19.7	22.8	28.1
Number of Refrigerant Circuits		1	1	1	1	1	1
Part Load Steps	%	0-50-100	0-50-100	0-50-100	0-44-56-100	0-50-100	0-50-100
Power Supply		400V/3/50Hz	400V/3/50Hz	400V/3/50Hz	400V/3/50Hz	400V/3/50Hz	400V/3/50Hz
Startup Type		Direct	Direct	Direct	Direct	Direct	Direct
Maximum Current (FLA)	A	Refer to electrical data					
Startup Current (LRA)	A						
<b>REFRIGERANT</b>							
Type		R410A					
<b>COMPRESSOR</b>							
Number		2	2	2	2	2	2
Type		Scroll	Scroll	Scroll	Scroll	Scroll	Scroll
Crankcase Heater	W	90	90	90	90	90	90
<b>COIL</b>							
Number		1	1	1	1	1	1
Frontal Surface	l x a	2160 x 1200	2160 x 1200	2160 x 1200	2650 x 1200	2650 x 1200	2650 x 1200
Row		2	2	3	3	3	3
<b>FANS</b>							
Number		1	1	1	1	1	1
Air Flow Rate	m³/h	11000	11000	10300	16000	16000	16000
Speed	rpm	530	530	530	720	720	720
Input Power	kW	0.57	0.57	0.57	1.27	1.27	1.27
<b>REFRIGERANT CONNECTIONS</b>							
Type		To be brazed					
Inlet Diameter	inch	5/8"	5/8"	5/8"	7/8"	7/8"	7/8"
Outlet Diameter	inch	1"3/8	1"3/8	1"3/8	1"3/8	1"3/8	1"3/8
<b>WEIGHT</b>							
Shipping Weight	kg	391	399	422	456	466	469
Operating Weight	kg	391	399	422	456	466	469
<b>DIMENSIONS</b>							
Length	mm	1750	1750	1750	2200	2200	2200
Width	mm	1100	1100	1100	1100	1100	1100
Height	mm	1580	1580	1580	1580	1580	1580
<b>ACOUSTIC DATA (NORMAL MODE)</b>							
Sound Power Level	dB(A)	74.0	75.3	75.3	78.0	78.5	79.0
Sound Pressure Level (1)	dB(A)	42.4	43.7	43.7	46.3	46.8	47.3

(1) Sound pressure calculated at 10 m.

## Physical Data - AQC 40 to 75 - R410A - SIF Version

AQC SIF		40	45	50	60	65	75
Cooling Capacity - (OAT 35 [°C], ET 7 [°C])	kW	45.8	52.1	61.3	68.4	75.2	85.9
Input Power (Compressor) - (OAT 35 [°C], ET 7 [°C])	kW	11.9	13.9	16.0	18.3	21.1	25.6
Number of Refrigerant Circuits		1	1	1	1	1	1
Part Load Steps	%	0-50-100	0-50-100	0-50-100	0-44-56-100	0-50-100	0-50-100
Power Supply		400V/3/50Hz	400V/3/50Hz	400V/3/50Hz	400V/3/50Hz	400V/3/50Hz	400V/3/50Hz
Startup Type		Direct	Direct	Direct	Direct	Direct	Direct
Maximum Current (FLA)	A	Refer to electrical data					
Startup Current (LRA)	A						
<b>REFRIGERANT</b>							
Type		R410A					
<b>COMPRESSOR</b>							
Number		2	2	2	2	2	2
Type		Scroll	Scroll	Scroll	Scroll	Scroll	Scroll
Crankcase Heater	W	90	90	90	90	90	90
<b>COIL</b>							
Number		1	1	1	1	1	1
Frontal Surface	l x a	2160 x 1200	2160 x 1200	2160 x 1200	2650 x 1200	2650 x 1200	2650 x 1200
Row		2	2	3	3	3	3
<b>FANS</b>							
Number		1	1	1	1	1	1
Air Flow Rate	m <sup>3</sup> /h	25284	25284	24300	25284	25284	25284
Speed	rpm	1110	1110	1110	1110	1110	1110
Input Power	kW	2.67	2.67	2.67	2.67	2.67	2.67
<b>REFRIGERANT CONNECTIONS</b>							
Type		To be brazed					
Inlet Diameter	inch	5/8"	5/8"	5/8"	7/8"	7/8"	7/8"
Outlet Diameter	inch	1"3/8	1"3/8	1"3/8	1"3/8	1"3/8	1"3/8
<b>WEIGHT</b>							
Shipping Weight	kg	391	399	422	456	466	469
Operating Weight	kg	391	399	422	456	466	469
<b>DIMENSIONS</b>							
Length	mm	1750	1750	1750	2200	2200	2200
Width	mm	1100	1100	1100	1100	1100	1100
Height	mm	1685	1685	1685	1685	1685	1685
<b>ACOUSTIC DATA (NORMAL MODE)</b>							
Sound Power Level	dB(A)	Refer to fan data - SIF version					
Sound Pressure Level (1)	dB(A)						

(1) Sound pressure calculated at 10 m.

## Fan Data - AQC 40 to 75 - R410A - SIF Version

Sizes	Fan static pressure (Pa)	Fan RPM	Sound power level - dB(A)
40	145	900	90
	195	1000	92
	220	1050	94
	245	1100	95
45	145	900	90
	195	1000	92
	220	1050	94
	245	1100	95
50	145	900	90
	195	1000	92
	220	1050	94
	245	1100	95
60	45	1000	93
	68	1050	94
	120	1100	95
65	45	1000	93
	68	1050	94
	120	1100	95
75	45	1000	93
	68	1050	94
	120	1100	95

## Electrical Data - AQC 40 to 75 - R410A - BLN Version

### Compressor data - 400 V/3 Ph/50 Hz

		Power input at nominal cond. per comp. [kW]	Nom. Cond. current per compressor [A]	Power input at max cond. per comp. [kW]	Current at max cond. per comp. FLA [A]	Start up current LRA [A]	Power factor @ nominal condition	Power factor @ maximum condition
40	COMP 1	6.3	11.3	9.1	16	95	0.8	0.8
	COMP 2	6.3	11.3	9.1	16	95	0.8	0.8
45	COMP 1	7.1	12.7	10.2	21	111	0.8	0.7
	COMP 2	7.1	12.7	10.2	21	111	0.8	0.7
50	COMP 1	8.3	15.3	12.0	22	118	0.8	0.8
	COMP 2	8.3	15.3	12.0	22	118	0.8	0.8
60	COMP 1	10.5	19.1	14.8	31	140	0.8	0.7
	COMP 2	8.3	15.3	12.0	22	118	0.8	0.8
65	COMP 1	10.5	19.1	14.8	31	140	0.8	0.7
	COMP 2	10.5	19.1	14.8	31	140	0.8	0.7
75	COMP 1	12.2	23.3	17.1	40	173	0.8	0.6
	COMP 2	12.2	23.3	17.1	40	173	0.8	0.6

### Units - 400 V/3 Ph/50 Hz

Sizes	BLN Unit Data					
	40	45	50	60	65	75
Power input [kW] max.	19	21	25	29	32	36
Current input [A] max.	34	44	46	57	66	84
Start-up current (A)	113	134	142	166	175	217

### Fan electrical data - 400 V/3 Ph/50 Hz

Sizes	Number	Standard fan Nominal power (kW)	Standard fan Max. running current (A)	
40	1	0.98	2.4	8p - Δ
45	1	0.98	2.4	8p - Δ
50	1	0.98	2.4	8p - Δ
60	1	2.00	4.3	6p - Δ
65	1	2.00	4.3	6p - Δ
75	1	2.00	4.3	6p - Δ

## Electrical Data - AQC 40 to 75 - R410A - ELN Version

### Compressor data - 400 V/3 Ph/50 Hz

		Power input at nominal cond. per comp. [kW]	Nom. Cond. current per compressor [A]	Power input at max cond. per comp. [kW]	Current at max cond. per comp. FLA [A]	Start up current LRA [A]	Power factor @ nominal condition	Power factor @ maximum condition
40	COMP 1	6.3	11.3	9.1	16	95	0.8	0.8
	COMP 2	6.3	11.3	9.1	16	95	0.8	0.8
45	COMP 1	7.1	12.7	10.2	21	111	0.8	0.7
	COMP 2	7.1	12.7	10.2	21	111	0.8	0.7
50	COMP 1	8.3	15.3	12.0	22	118	0.8	0.8
	COMP 2	8.3	15.3	12.0	22	118	0.8	0.8
60	COMP 1	10.5	19.1	14.8	31	140	0.8	0.7
	COMP 2	8.3	15.3	12.0	22	118	0.8	0.8
65	COMP 1	10.5	19.1	14.8	31	140	0.8	0.7
	COMP 2	10.5	19.1	14.8	31	140	0.8	0.7
75	COMP 1	12.2	23.3	17.1	40	173	0.8	0.6
	COMP 2	12.2	23.3	17.1	40	173	0.8	0.6

### Units - 400 V/3 Ph/50 Hz

Sizes	ELN Unit Data					
	40	45	50	60	65	75
Power input [kW] max.	19	21	24	28	31	35
Current input [A] max.	33	43	45	56	65	83
Start-up current (A)	112	133	141	165	174	216

### Fan electrical data - 400 V/3 Ph/50 Hz

Sizes	Number	Standard fan Nominal power (kW)	Standard fan Max. running current (A)	
40	1	0.57	1.2	8p - Y
45	1	0.57	1.2	8p - Y
50	1	0.57	1.2	8p - Y
60	1	1.27	2.5	6p - Y
65	1	1.27	2.5	6p - Y
75	1	1.27	2.5	6p - Y

## Electrical Data - AQC 40 to 75 - R410A - SIF Version

### Compressor data - 400 V/3 Ph/50 Hz

		Power input at nominal cond. per comp. [kW]	Nom. Cond. current per compressor [A]	Power input at max cond. per comp. [kW]	Current at max cond. per comp. FLA [A]	Start up current LRA [A]	Power factor @ nominal condition	Power factor @ maximum condition
40	COMP 1	6.3	11.3	9.1	16	95	0.8	0.8
	COMP 2	6.3	11.3	9.1	16	95	0.8	0.8
45	COMP 1	7.1	12.7	10.2	21	111	0.8	0.7
	COMP 2	7.1	12.7	10.2	21	111	0.8	0.7
50	COMP 1	8.3	15.3	12.0	22	118	0.8	0.8
	COMP 2	8.3	15.3	12.0	22	118	0.8	0.8
60	COMP 1	10.5	19.1	14.8	31	140	0.8	0.7
	COMP 2	8.3	15.3	12.0	22	118	0.8	0.8
65	COMP 1	10.5	19.1	14.8	31	140	0.8	0.7
	COMP 2	10.5	19.1	14.8	31	140	0.8	0.7
75	COMP 1	12.2	23.3	17.1	40	173	0.8	0.6
	COMP 2	12.2	23.3	17.1	40	173	0.8	0.6

### Units - 400 V/3 Ph/50 Hz

Sizes	SIF Unit Data					
	40	45	50	60	65	75
Power input [kW] max.	21	23	27	29	32	37
Current input [A] max.	36	46	48	57	66	84
Start-up current (A)	115	136	144	166	175	217

### Fan electrical data - 400 V/3 Ph/50 Hz

Sizes	Number	Standard fan Nominal power (kW)	Standard fan Max. running current (A)
40	1	2.67	4.1
45	1	2.67	4.1
50	1	2.67	4.1
60	1	2.67	4.1
65	1	2.67	4.1
75	1	2.67	4.1

## Sound Data - AQC 40 to 75 - R410A

### Sound power levels - Lw in dB(A) - BLN version

Sizes	Frequencies (Hz)								Lw(A) Global dB
	63	125	250	500	1000	2000	4000	8000	
AQC 40	74.7	91.2	76.6	76.9	74.8	71.0	62.0	55.2	<b>80.5</b>
AQC 45	74.9	91.5	76.7	77.5	76.0	71.1	62.1	55.4	<b>81.0</b>
AQC 50	74.9	91.5	76.7	77.5	76.0	71.1	62.1	55.4	<b>81.0</b>
AQC 60	77.2	94.6	80.7	82.0	81.1	76.2	66.5	59.2	<b>85.5</b>
AQC 65	77.1	94.4	80.9	82.5	81.2	76.3	66.7	59.3	<b>85.6</b>
AQC 75	77.5	95.0	81.0	82.7	81.1	76.4	66.9	59.5	<b>85.8</b>

### Sound power levels - Lw in dB(A) - ELN version

Sizes	Frequencies (Hz)								Lw(A) Global dB
	63	125	250	500	1000	2000	4000	8000	
AQC 40	69.5	72.4	70.4	71.3	70.5	65.6	57.0	51.0	<b>74.0</b>
AQC 45	73.1	76.4	74.7	73.4	70.9	65.5	58.6	48.3	<b>75.3</b>
AQC 50	73.1	76.4	74.7	73.4	70.9	65.5	58.6	48.3	<b>75.3</b>
AQC 60	72.3	88.5	75.1	74.0	72.8	68.5	59.1	52.1	<b>78.0</b>
AQC 65	73.3	89.6	75.2	74.1	73.0	68.7	59.0	52.0	<b>78.5</b>
AQC 75	73.5	89.9	75.5	75.0	73.7	69.2	60.5	53.4	<b>79.0</b>

### Sound power levels - Lw in dB(A) - SIF\* version

Sizes	Frequencies (Hz)								Lw(A) Global dB
	63	125	250	500	1000	2000	4000	8000	
AQC 40	82.8	99.1	90.3	93.5	91.4	85.3	75.0	68.5	<b>95.2</b>
AQC 45	82.8	99.1	90.3	93.5	91.4	85.3	75.0	68.5	<b>95.2</b>
AQC 50	82.8	99.1	90.3	93.5	91.4	85.3	75.0	68.5	<b>95.2</b>
AQC 60	83.1	99.9	90.4	93.6	91.5	85.4	75.1	68.7	<b>95.3</b>
AQC 65	83.1	99.9	90.4	93.6	91.5	85.4	75.1	68.7	<b>95.3</b>
AQC 75	83.1	99.9	90.4	93.6	91.5	85.4	75.1	68.7	<b>95.3</b>

\* Sound data referred to a fan speed of 1110 rpm.

Compressor jacket (standard on ELN) can be ordered as accessory. Compressor jacket impact = -2 dB(A).

## Sound Data - AQC 40 to 75 - R410A (continued)

### Sound pressure levels - Lp in dB(A) - BLN version

Sizes	Frequencies (Hz)								Lp(A) Global dB
	63	125	250	500	1000	2000	4000	8000	
AQC 40	43.1	59.6	45.0	45.3	43.2	39.4	30.4	23.6	<b>48.9</b>
AQC 45	43.3	59.9	45.1	45.9	44.4	39.5	30.5	23.8	<b>49.4</b>
AQC 50	43.3	59.9	45.1	45.9	44.4	39.5	30.5	23.8	<b>49.4</b>
AQC 60	45.5	62.9	49.0	50.3	49.4	44.5	34.8	27.5	<b>53.8</b>
AQC 65	45.4	62.7	49.2	50.8	49.5	44.6	35.0	27.6	<b>53.9</b>
AQC 75	45.8	63.3	49.3	51.0	49.4	44.7	35.2	27.8	<b>54.1</b>

### Sound pressure levels - Lp in dB(A) - ELN version

Sizes	Frequencies (Hz)								Lp(A) Global dB
	63	125	250	500	1000	2000	4000	8000	
AQC 40	37.9	40.8	38.8	39.7	38.9	34.0	25.4	19.4	<b>42.4</b>
AQC 45	41.5	44.8	43.1	41.8	39.3	33.9	27.0	16.7	<b>43.7</b>
AQC 50	41.5	44.8	43.1	41.8	39.3	33.9	27.0	16.7	<b>43.7</b>
AQC 60	40.6	56.8	43.4	42.3	41.1	36.8	27.4	20.4	<b>46.3</b>
AQC 65	41.6	57.9	43.5	42.4	41.3	37.0	27.3	20.3	<b>46.8</b>
AQC 75	41.8	58.2	43.8	43.3	42.0	37.5	28.8	21.7	<b>47.3</b>

### Sound pressure levels - Lp in dB(A) - SIF\* version

Sizes	Frequencies (Hz)								Lp(A) Global dB
	63	125	250	500	1000	2000	4000	8000	
AQC 40	51.2	67.5	58.7	61.9	59.8	53.7	43.4	36.9	<b>63.6</b>
AQC 45	51.2	67.5	58.7	61.9	59.8	53.7	43.4	36.9	<b>63.6</b>
AQC 50	51.2	67.5	58.7	61.9	59.8	53.7	43.4	36.9	<b>63.6</b>
AQC 60	51.4	68.2	58.7	61.9	59.8	53.7	43.4	37.0	<b>63.6</b>
AQC 65	51.4	68.2	58.7	61.9	59.8	53.7	43.4	37.0	<b>63.6</b>
AQC 75	51.4	68.2	58.7	61.9	59.8	53.7	43.4	37.0	<b>63.6</b>

Sound pressure level calculated at a distance of 10 metre. Sound pressure levels refer to ISO standard 3744 with parallelepiped shape.

\* Sound data referred to a fan speed of 1110 rpm.

Compressor jacket (standard on ELN) can be ordered as accessory. Compressor jacket impact = -2 dB(A).

## Performance Data - AQC 40 to 75 - R410A - BLN Version

AQC BLN sizes	ET (°C)	Ambient air temperature (°C)													
		25		30		32		35		40		43		46	
		Cool. cap. (kW)	Input power* (kW)	Cool. cap. (kW)	Input power* (kW)	Cool. cap. (kW)	Input power* (kW)	Cool. cap. (kW)	Input power* (kW)	Cool. cap. (kW)	Input power* (kW)	Cool. cap. (kW)	Input power* (kW)	Cool. cap. (kW)	Input power* (kW)
AQC 40 BLN	1	40.9	10.1	38.6	11.1	37.8	11.6	36.3	12.2	33.9	13.4	32.4	14.2	30.8	15.0
	3	43.5	10.4	41.0	11.3	40.1	11.8	38.6	12.5	35.9	13.6	34.4	14.4	32.8	15.1
	5	46.0	10.6	43.5	11.6	42.5	12.0	40.9	12.7	38.1	13.8	36.4	14.6		
	7	48.7	10.9	46.0	11.9	44.9	12.3	<b>43.2</b>	<b>13.0</b>	40.3	14.1	38.6	14.8		
	9	51.6	11.1	48.6	12.1	47.5	12.5	45.6	13.2	42.7	14.4	40.8	15.1		
	11	54.4	11.4	51.4	12.4	50.2	12.8	48.1	13.5	45.1	14.7				
	14	58.9	11.8	54.1	12.7	52.8	13.1	52.2	14.1	48.9	15.3				
AQC 45 BLN	1	46.3	12.0	43.7	13.1	42.7	13.7	41.1	14.5	38.4	15.8	36.6	16.8	34.9	17.7
	3	49.2	12.3	46.4	13.4	45.4	14.0	43.6	14.8	40.6	16.1	38.9	17.0	37.1	17.9
	5	52.1	12.6	49.2	13.7	48.1	14.2	46.3	15.1	43.1	16.3	41.2	17.3		
	7	55.2	12.9	52.0	14.1	50.9	14.6	<b>48.8</b>	<b>15.3</b>	45.6	16.7	43.6	17.5		
	9	58.4	13.1	55.0	14.4	53.8	14.8	51.6	15.6	48.3	17.0	46.1	17.9		
	11	61.6	13.5	58.2	14.7	56.8	15.2	54.5	16.0	51.0	17.4				
	14	66.6	14.0	61.3	15.0	59.7	15.6	59.1	16.6	55.4	18.1				
AQC 50 BLN	1	53.9	13.9	50.9	15.2	49.8	15.9	47.9	16.8	44.7	18.4	42.7	19.4	40.7	20.5
	3	57.3	14.3	54.1	15.6	52.9	16.2	50.9	17.1	47.4	18.7	45.3	19.8	43.2	20.8
	5	60.7	14.6	57.3	15.9	56.0	16.5	53.9	17.5	50.2	19.0	48.0	20.0		
	7	64.3	14.9	60.7	16.3	59.3	16.9	<b>56.9</b>	<b>17.8</b>	53.2	19.4	50.9	20.4		
	9	68.0	15.2	64.1	16.6	62.7	17.2	60.2	18.1	56.3	19.8	53.8	20.8		
	11	71.7	15.7	67.8	17.1	66.2	17.6	63.5	18.5	59.4	20.2				
	14	77.7	16.2	71.4	17.4	69.6	18.0	68.9	19.3	64.5	21.0				
AQC 60 BLN	1	63.9	14.7	60.3	16.0	59.0	16.7	56.7	17.7	52.9	19.3	50.5	20.5	48.1	21.6
	3	67.9	15.0	64.1	16.4	62.6	17.1	60.2	18.0	56.1	19.7	53.7	20.8	51.2	21.9
	5	71.9	15.4	67.9	16.7	66.4	17.4	63.9	18.4	59.5	20.0	56.9	21.1		
	7	76.1	15.7	71.8	17.2	70.2	17.8	<b>67.4</b>	<b>18.7</b>	63.0	20.4	60.2	21.4		
	9	80.6	16.0	75.9	17.5	74.2	18.1	71.3	19.1	66.7	20.8	63.7	21.9		
	11	85.0	16.5	80.3	18.0	78.4	18.6	75.2	19.5	70.4	21.3				
	14	92.0	17.1	84.6	18.3	82.5	19.0	81.6	20.3	76.4	22.1				
AQC 65 BLN	1	69.9	16.9	66.0	18.5	64.6	19.3	62.1	20.4	58.0	22.3	55.3	23.6	52.7	24.9
	3	74.3	17.3	70.1	18.9	68.6	19.7	65.9	20.8	61.4	22.7	58.8	24.0	56.1	25.1
	5	78.8	17.7	74.3	19.3	72.7	20.0	69.9	21.2	65.1	23.0	62.3	24.3		
	7	83.4	18.1	78.6	19.8	76.9	20.5	<b>73.8</b>	<b>21.6</b>	69.0	23.5	65.9	24.7		
	9	88.2	18.5	83.1	20.2	81.3	20.9	78.0	22.0	73.0	24.0	69.7	25.1		
	11	93.0	19.0	87.9	20.7	85.8	21.4	82.3	22.5	77.1	24.5				
	14	100.7	19.7	92.6	21.1	90.3	21.9	89.4	23.4	83.7	25.4				
AQC 75 BLN	1	80.0	20.6	75.6	22.5	73.9	23.5	71.0	24.8	66.3	27.2	63.3	28.7	60.3	30.3
	3	85.1	21.1	80.2	23.0	78.4	24.0	75.4	25.3	70.3	27.6	67.3	29.2	64.1	30.7
	5	90.1	21.5	85.1	23.5	83.1	24.4	80.0	25.8	74.5	28.0	71.2	29.6		
	7	95.4	22.0	90.0	24.1	87.9	25.0	<b>84.5</b>	<b>26.3</b>	78.9	28.6	75.4	30.1		
	9	100.9	22.5	95.0	24.6	93.0	25.4	89.3	26.8	83.5	29.2	79.8	30.7		
	11	106.4	23.1	100.5	25.2	98.1	26.1	94.2	27.4	88.2	29.8				
	14	115.2	24.0	106.0	25.7	103.3	26.7	102.2	28.5	95.7	31.0				

\* Compressors only.  
**ET** : Evaporating temperature.

## Performance Data - AQC 40 to 75 - R410A - ELN Version

AQC ELN sizes	ET (°C)	Ambient air temperature (°C)											
		25		30		32		35		40		43	
		Cool. cap. (kW)	Input power* (kW)	Cool. cap. (kW)	Input power* (kW)	Cool. cap. (kW)	Input power* (kW)	Cool. cap. (kW)	Input power* (kW)	Cool. cap. (kW)	Input power* (kW)	Cool. cap. (kW)	Input power* (kW)
AQC 40 ELN	1	39.4	10.7	37.3	11.7	36.4	12.2	35.0	12.9	32.7	14.1	31.2	14.9
	3	41.9	10.9	39.6	12.0	38.7	12.5	37.2	13.2	34.6	14.4	33.2	15.2
	5	44.4	11.2	41.9	12.2	41.0	12.7	39.4	13.4	36.7	14.5		
	7	47.0	11.4	44.4	12.5	43.4	13.0	<b>41.6</b>	<b>13.7</b>	38.9	14.9		
	9	49.8	11.7	46.9	12.8	45.8	13.2	44.0	13.9	41.2	15.2		
	11	52.5	12.0	49.6	13.1	48.4	13.5	46.4	14.2				
	14	56.8	12.5	52.2	13.3	50.9	13.9	50.4	14.8				
AQC 45 ELN	1	44.3	12.8	41.8	14.0	40.9	14.6	39.3	15.4	36.7	16.8	35.0	17.8
	3	47.1	13.1	44.4	14.3	43.4	14.9	41.8	15.7	38.9	17.1	37.2	18.1
	5	49.9	13.4	47.1	14.6	46.0	15.1	44.3	16.0	41.2	17.4		
	7	52.8	13.7	49.8	14.9	48.7	15.5	<b>46.7</b>	<b>16.3</b>	43.7	17.7		
	9	55.9	14.0	52.6	15.2	51.5	15.8	49.4	16.6	46.2	18.1		
	11	58.9	14.3	55.7	15.6	54.3	16.1	52.1	17.0				
	14	63.8	14.9	58.6	15.9	57.2	16.5	56.6	17.7				
AQC 50 ELN	1	51.1	15.0	48.3	16.4	47.2	17.1	45.4	18.1	42.4	19.7	40.5	20.9
	3	54.4	15.3	51.3	16.7	50.1	17.4	48.2	18.4	44.9	20.1	43.0	21.2
	5	57.6	15.7	54.4	17.1	53.1	17.7	51.1	18.8	47.6	20.4		
	7	61.0	16.0	57.5	17.5	56.2	18.1	<b>54.0</b>	<b>19.1</b>	50.4	20.8		
	9	64.5	16.4	60.7	17.9	59.4	18.5	57.0	19.5	53.4	21.2		
	11	68.0	16.8	64.3	18.3	62.7	18.9	60.2	19.9				
	14	73.6	17.4	67.7	18.7	66.0	19.4	65.3	20.7				
AQC 60 ELN	1	61.5	15.4	58.1	16.9	56.8	17.6	54.5	18.6	50.9	20.4	48.6	21.6
	3	65.3	15.8	61.7	17.3	60.3	18.0	58.0	19.0	54.0	20.8	51.7	21.9
	5	69.2	16.2	65.3	17.6	63.9	18.3	61.5	19.4	57.2	21.0		
	7	73.3	16.5	69.1	18.1	67.6	18.7	<b>64.9</b>	<b>19.7</b>	60.6	21.5		
	9	77.5	16.9	73.0	18.5	71.4	19.1	68.6	20.1	64.1	21.9		
	11	81.8	17.4	77.3	18.9	75.4	19.6	72.4	20.6				
	14	88.5	18.0	81.4	19.3	79.4	20.0	78.5	21.4				
AQC 65 ELN	1	67.0	17.8	63.3	19.5	61.9	20.3	59.5	21.5	55.5	23.5	53.0	24.9
	3	71.2	18.2	67.2	19.9	65.7	20.8	63.2	21.9	58.9	23.9	56.3	25.3
	5	75.5	18.6	71.2	20.3	69.6	21.1	67.0	22.3	62.4	24.2		
	7	79.9	19.1	75.4	20.9	73.7	21.6	<b>70.7</b>	<b>22.8</b>	66.1	24.8		
	9	84.5	19.5	79.6	21.3	77.9	22.0	74.8	23.2	69.9	25.3		
	11	89.1	20.0	84.2	21.8	82.2	22.5	78.9	23.7				
	14	96.5	20.8	88.7	22.2	86.5	23.1	85.6	24.6				
AQC 75 ELN	1	76.3	22.0	72.1	24.1	70.5	25.1	67.7	26.5	63.3	29.0	60.4	30.7
	3	81.1	22.5	76.6	24.6	74.8	25.6	72.0	27.1	67.0	29.5	64.2	31.2
	5	86.0	23.0	81.1	25.1	79.3	26.0	76.3	27.6	71.1	29.9		
	7	91.0	23.5	85.8	25.8	83.9	26.7	<b>80.6</b>	<b>28.1</b>	75.3	30.6		
	9	96.3	24.1	90.7	26.3	88.7	27.2	85.2	28.6	79.7	31.2		
	11	101.5	24.7	95.9	26.9	93.6	27.8	89.9	29.3				
	14	109.9	25.6	101.1	27.4	98.6	28.5	97.5	30.4				

\* Compressors only.  
ET : Evaporating temperature.

# Performance Data - AQC 40 to 75 - R410A - SIF Version

AQC SIF sizes	ET (°C)	Ambient air temperature (°C)																	
		25		30		32		35		40		43		46		48		50	
		Cool. cap. (kW)	Input power* (kW)	Cool. cap. (kW)	Input power* (kW)	Cool. cap. (kW)	Input power* (kW)	Cool. cap. (kW)	Input power* (kW)	Cool. cap. (kW)	Input power* (kW)	Cool. cap. (kW)	Input power* (kW)	Cool. cap. (kW)	Input power* (kW)	Cool. cap. (kW)	Input power* (kW)	Cool. cap. (kW)	Input power* (kW)
AQC 40 SIF	1	43.4	9.3	41.0	10.2	40.1	10.7	38.5	11.3	36.0	12.3	34.3	13.0	32.7	13.8	31.7	14.3	30.6	14.7
	3	46.1	9.6	43.5	10.4	42.5	10.9	40.9	11.5	38.1	12.5	36.5	13.3	34.8	13.9	33.6	14.4	32.5	14.9
	5	48.9	9.8	46.1	10.7	45.1	11.0	43.4	11.7	40.4	12.7	38.6	13.4	36.8	14.1	35.6	14.6		
	7	51.7	10.0	48.8	10.9	47.7	11.3	<b>45.8</b>	<b>11.9</b>	42.8	13.0	40.9	13.6	39.0	14.3	37.7	14.8		
	9	54.7	10.2	51.5	11.2	50.4	11.5	48.4	12.2	45.3	13.3	43.3	13.9	41.2	14.6	39.9	15.1		
	11	57.7	10.5	54.5	11.4	53.2	11.8	51.1	12.4	47.8	13.5	45.7	14.2	43.7	14.9				
14	62.5	10.9	57.5	11.7	56.0	12.1	55.4	12.9	51.9	14.1	49.7	14.9	47.6	15.6					
AQC 45 SIF	1	49.3	10.9	46.6	11.9	45.5	12.4	43.8	13.1	40.9	14.3	39.0	15.2	37.2	16.0	36.0	16.6	34.8	17.1
	3	52.4	11.1	49.5	12.2	48.4	12.7	46.5	13.4	43.3	14.6	41.5	15.4	39.5	16.2	38.1	16.8	36.9	17.3
	5	55.5	11.4	52.4	12.4	51.2	12.9	49.3	13.6	45.9	14.8	43.9	15.6	41.8	16.5	40.5	17.0		
	7	58.8	11.6	55.5	12.7	54.2	13.2	<b>52.1</b>	<b>13.9</b>	48.6	15.1	46.5	15.9	44.3	16.7	42.9	17.2		
	9	62.2	11.9	58.6	13.0	57.3	13.4	55.0	14.2	51.5	15.4	49.2	16.2	46.9	17.0	45.4	17.6		
	11	65.6	12.2	62.0	13.3	60.5	13.8	58.1	14.5	54.4	15.8	52.0	16.5	49.6	17.4				
14	71.0	12.7	65.3	13.6	63.7	14.1	63.0	15.1	59.0	16.4	56.5	17.3	54.1	18.2					
AQC 50 SIF	1	58.1	12.5	54.8	13.7	53.6	14.3	51.5	15.1	48.1	16.5	45.9	17.4	43.8	18.4	42.4	19.1	41.0	19.7
	3	61.7	12.8	58.2	14.0	56.9	14.6	54.8	15.4	51.0	16.8	48.8	17.7	46.6	18.6	44.9	19.3	43.5	19.9
	5	65.4	13.1	61.7	14.3	60.3	14.8	58.1	15.7	54.1	17.0	51.7	18.0	49.3	18.9	47.7	19.5		
	7	69.2	13.4	65.3	14.6	63.8	15.1	<b>61.3</b>	<b>16.0</b>	57.3	17.4	54.8	18.3	52.1	19.1	50.5	19.8		
	9	73.2	13.7	69.0	14.9	67.5	15.4	64.8	16.3	60.6	17.7	57.9	18.6	55.2	19.5	53.4	20.2		
	11	77.2	14.0	73.0	15.3	71.2	15.8	68.4	16.6	64.0	18.1	61.2	19.0	58.4	20.0				
14	83.6	14.6	76.9	15.6	75.0	16.2	74.2	17.3	69.5	18.8	66.5	19.9	63.6	20.9					
AQC 60 SIF	1	64.8	14.3	61.2	15.7	59.8	16.4	57.5	17.3	53.7	18.9	51.3	20.0	48.8	21.1	47.3	21.9		
	3	68.9	14.7	65.0	16.0	63.5	16.7	61.1	17.6	56.9	19.3	54.5	20.4	51.9	21.4				
	5	73.0	15.0	68.9	16.4	67.3	17.0	64.8	18.0	60.3	19.5	57.7	20.6	55.0	21.7				
	7	77.2	15.4	72.9	16.8	71.2	17.4	<b>68.4</b>	<b>18.3</b>	63.9	19.9	61.1	21.0	58.2	22.0				
	9	81.7	15.7	76.9	17.1	75.3	17.7	72.3	18.7	67.6	20.4	64.6	21.4						
	11	86.2	16.1	81.4	17.6	79.5	18.2	76.3	19.1	71.4	20.8	68.3	21.8						
14	93.3	16.7	85.8	17.9	83.7	18.6	82.8	19.9	77.5	21.6									
AQC 65 SIF	1	71.3	16.5	67.3	18.1	65.8	18.8	63.2	19.9	59.1	21.8	56.4	23.0	53.7	24.3	52.0	25.2		
	3	75.8	16.9	71.5	18.4	69.9	19.2	67.2	20.3	62.6	22.1	59.9	23.4	57.1	24.6				
	5	80.2	17.3	75.8	18.8	74.0	19.5	71.3	20.7	66.3	22.4	63.4	23.7	60.5	25.0				
	7	85.0	17.7	80.1	19.3	78.3	20.0	<b>75.2</b>	<b>21.1</b>	70.3	22.9	67.2	24.1	64.0	25.3				
	9	89.9	18.1	84.6	19.7	82.8	20.4	79.5	21.5	74.4	23.4	71.0	24.6						
	11	94.8	18.5	89.6	20.2	87.4	20.9	83.9	22.0	78.5	23.9	75.1	25.1						
14	102.6	19.2	94.4	20.6	92.0	21.4	91.1	22.8	85.3	24.9									
AQC 75 SIF	1	81.4	20.0	76.9	21.9	75.2	22.9	72.2	24.2	67.5	26.4	64.4	27.9	61.4	29.5	59.4	30.6		
	3	86.5	20.5	81.6	22.4	79.8	23.3	76.8	24.6	71.5	26.9	68.4	28.4	65.3	29.8				
	5	91.7	21.0	86.5	22.9	84.6	23.7	81.4	25.1	75.8	27.2	72.5	28.8	69.1	30.3				
	7	97.0	21.4	91.5	23.4	89.5	24.3	<b>85.9</b>	<b>25.6</b>	80.3	27.8	76.8	29.2	73.1	30.7				
	9	102.7	21.9	96.7	23.9	94.6	24.7	90.8	26.1	84.9	28.4	81.2	29.8						
	11	108.3	22.5	102.3	24.5	99.9	25.3	95.8	26.6	89.7	29.0	85.8	30.4						
14	117.2	23.3	107.8	25.0	105.1	25.9	104.0	27.7	97.4	30.2									

\* Compressors only.  
 ET : Evaporating temperature.

# Dimensions (mm) - AQC 40 to 50 - R410A

**Bottom view**

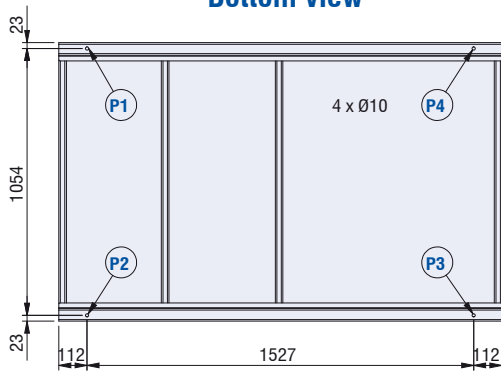

**Front view**

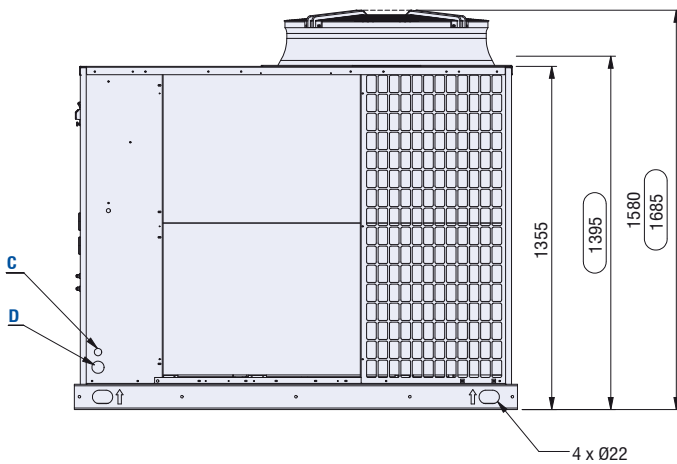
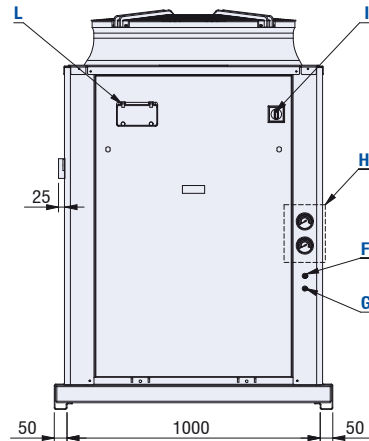

**Side view**

**Top view**

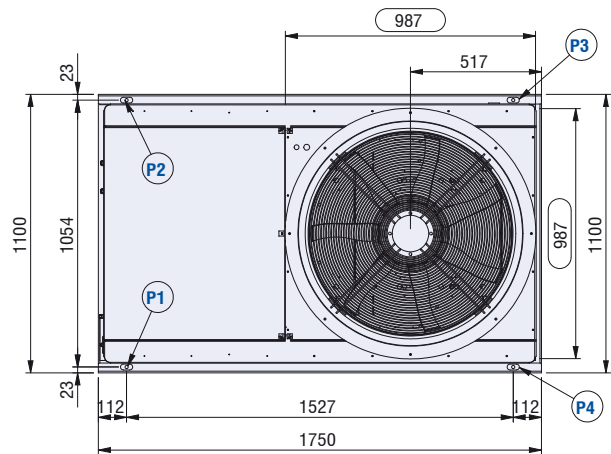
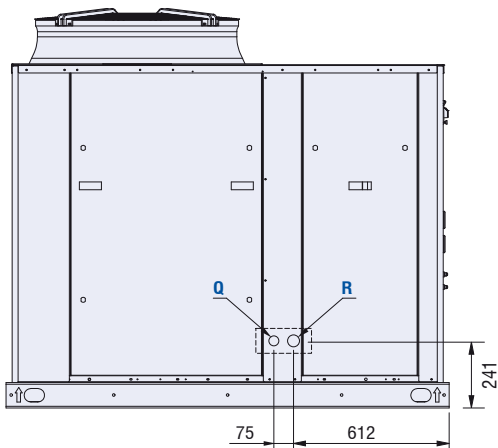

<b>C</b>	Electrical auxiliary lines
<b>D</b>	Electrical power supply
<b>F</b>	High pressure tap
<b>G</b>	Low pressure tap
<b>H</b>	Gauge kit (accessory)
<b>I</b>	Main switch
<b>L</b>	Control keypad/display

<b>XXX</b>	Only for SIF fan model
<b>P1, P2, P3, P4</b>	AVM position
<b>Q</b>	Liquid line Ø 5/8"
<b>R</b>	Suction line Ø 1 3/8"



## Unit Clearances (mm) - AQC 40 to 75 - R410A

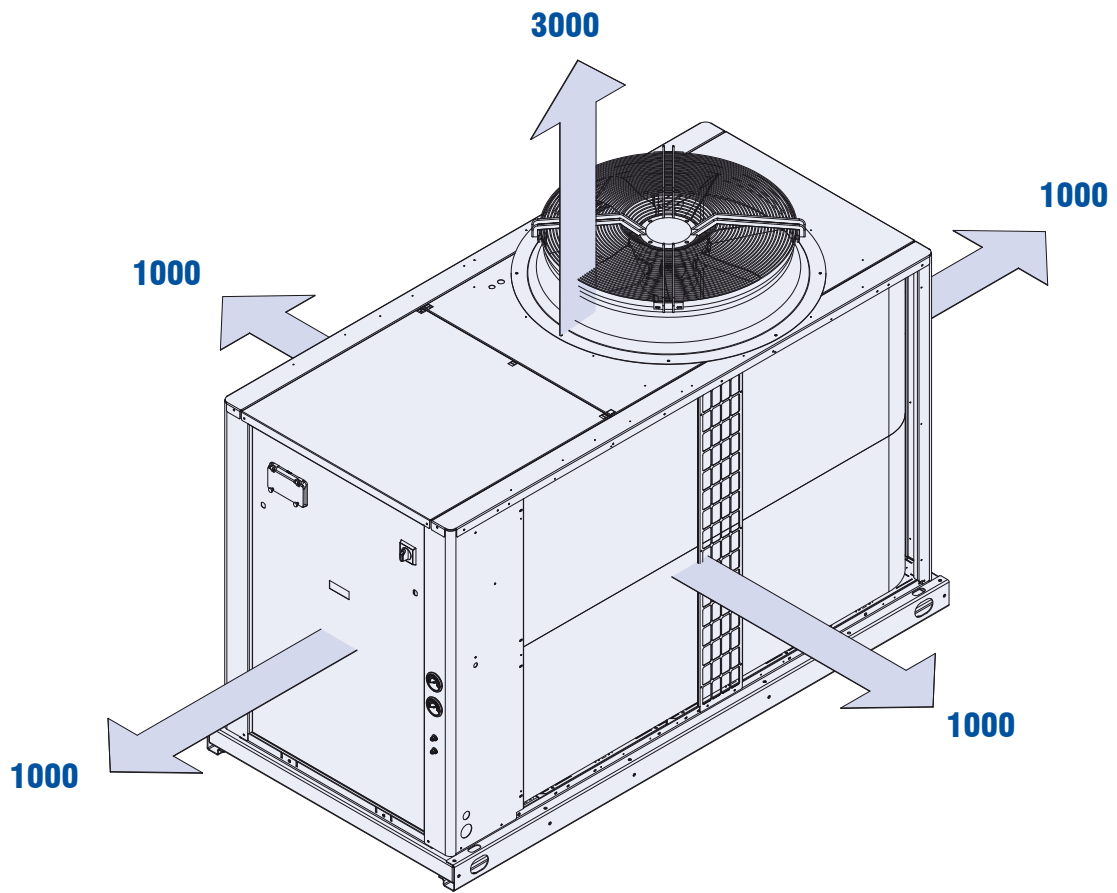



**AIRWELL France SAS**

1bis, Avenue du 8 mai 1945  
 Saint Quentin en Yvelines  
 78284 Guyancourt Cedex  
 France

Tel. +33 (0) 01 39 44 78 00  
 Fax +33 (0) 01 39 44 65 17  
[www.airwell.fr](http://www.airwell.fr)

**AIRWELL Italia Srl**

Via XXV Aprile 29  
 20030 Barlassina (MI)  
 Italy

Tel. +39 0362 525 51  
 Fax +39 0362 525 690  
[www.airwell.it](http://www.airwell.it)

**AIRWELL Deutschland GmbH**

Berner Str. 43  
 D-60437 Frankfurt  
 Germany

Tel. +49 (0) 69 50 70 21 20  
 Fax +49 (0) 69 50 70 22 50  
[www.airwell.de](http://www.airwell.de)

**AIRWELL Ibérica S.A.**

Avenida Castilla, 50  
 28830 San Fernando de Henares  
 (Madrid)  
 Spain

Tel. +34 91 710 04 60  
 Fax +34 91 710 91 96  
[www.airwell-iberica.es](http://www.airwell-iberica.es)

Ref. : EDM AQC-A.2GB/08.11 - Supersedes : EDM AQC-A.1GB/11.10

As part of our ongoing product improvement programme, our products are subject to change without prior notice. Non contractual photos.

**Airwell Group**

Airwell Group (Headquarter)  
 1bis, Avenue du 8 mai 1945  
 Saint Quentin en Yvelines  
 78284 GUYANCOURT  
 France