

K-OG

Chilled Water Cassettes

Models 30 & 45



Design Features

Introduction

Chilled Water units of the "Cassette" type offer comfortable air conditioning at a low cost of installation.

They fit harmoniously into standard modules of a false ceiling thanks to their design and small space requirements.

They are easy to be connected with water chillers producing chilled or hot water, and are used for :

- Cooling (Chilled Water) and Heating (Electric Heating).
- Heating (Hot Water). Simultaneous operation of Heating (Hot Water) and Electric Heating is strictly FORBIDDEN.

Cassette air treatment unit

It combines excellent technical qualities, reliability and easiness of installation. It includes :

- A flat (287 mm thick), insulated unit, flash mounted to be fitted into the false-ceiling, of a size compatible with standard modules of a false-ceiling (600 x 600 mm).
- Three-speed ventilation.
- Built-in electric heating to be connected on site.
- Condensate pump to lift at the top of the cassette. Draining should be provided for by gravity.
- Electric box of control and overload protection to be mounted on site.
- Combined discharge/air return grille with airfilter, discharge adjustable by hand on all 4 sides, air return at the center.

Casing

- Panels and insulated sheet.
- Combined discharge/air return grille supplied separately for the Cassette.
- Possible hand operated adjustment of air distribution on all four sides. Possibility to close one or two faces of discharge.
- Air return at center with filter.
- Prepunched holes for connection with fresh air intake and connection with a stub duct to treat an adjacent room. In that case it becomes necessary to provide a decompression in the adjacent room (grille ...) to allow air return on the Cassette.

Insulation

Heat and sound insulation throughout the indoor air treatment unit.

Ventilation

- Centrifugal turbine with direct drive.
- Motors mounted on rubbers and equipped with internal thermal safety devices. 3-speed motor for the air treatment unit.

Filtration

Cleanable air filter accessible after opening the discharge/intake combined grille.

- Filter type : Rapidly removable cassettes
- Media : Woven synthetics
- Fire resistance : M4 (PV LNE N° 812 02 29 to 30/01/89)
- Efficiency : 55% (EUROVENT 4/5 - ASHRAE gravimetric 52-76 NF X 44-012)
- Maintenance : Washable (cold water with detergent not more than 25 washings) or dry dedusting.

Electric heating

- The Cassettes are factory-equipped with electric heating to be connected on site.
- The electric heating equipped with heating resistances is heat protected against any abnormal raise of temperature by two thermostats :
 - a thermostat with automatic reset,
 - a thermostat with manual reset.

Kits available

Several kits are available :

- Condensate tray kit.
- Motorized 3-way valve kit with by-pass.
- Controls : TRM-VP (kit), TRM-FA (kit), TAE 20 (kit), TAE 20 + SEH (kit), Aqu@Simp and Aqu@Net.

Technical Data

MODELS		Size 30 - 2-pipe	Size 45 - 2-pipe	Size 45 - 4-pipe						
Nominal cooling capacity (1) - Nominal supply voltage 230V/50Hz	W	6440	10190	10100						
Nominal heating capacity (2) - Nominal supply voltage 230V/50Hz	W	8050	11600	6670						
AIR FLOW (AVERAGE VALUES) TREATED AIR										
High speed	m³/h	1550	1630	1725						
Medium speed	m³/h	1350	1250	1360						
Low speed	m³/h	1100	1000	1075						
Nominal water flow (average values)	m³/h	1.208	1.753	1.89						
Pressure loss on water (3)	kPa	17	23.5	34.3						
Contents	l	2.7	4	4						
Power supply	V	~230 V - 50 Hz 3N~400 V - 50 Hz								
Voltage range	V	207 / 253 V 360 / 440 V								
Power input ventilation	W	200	180	180						
SOUND POWER LEVEL		Size 30 - 2-pipe			Size 45 - 2-pipe			Size 45 - 4-pipe		
		Lw global	Lp* global	NR	Lw global	Lp* global	NR	Lw global	Lp* global	NR
High speed	dBA	57	49	44	59	51	45	59	51	45
Medium speed	dBA	50	42	37	53	45	40	53	45	40
Low speed	dBA	47	39	34	47	39	34	47	39	34
DIMENSIONS										
Casing (L x P x H)	mm	1171 x 571 x 287								
Grille (L x P x H)	mm	1225 x 625 x 40								
Net weight	kg	49	55	55						
PACKING										
Gross weight	kg	51	58	58						
Packed volume	m³	0.31	0.31	0.31						
ACCESSORIES										
Electric heating (4) nominal capacity	W	4300	5400	-						
Motorized 3-way valve with by-pass		●	●	●						
Condensate tray for valve		●	●	●						

Note :

- (1) Nominal conditions : Air : 27 °C/19 °C wet bulb (nominal HS airflow) - Chilled water : 7 °C/12 °C.
 - (2) Nominal conditions : Air : 20 °C (nominal HS airflow) - Hot water : 50 °C (nominal waterflow in chilled water mode).
 - (3) Pressure loss by corresponding nominal flow.
 - (4) At nominal airflow, at 20 °C, under 230 V (see page 6).
 - (*) The sound pressure levels Lp are based on (NR) characteristics of a room having volume of 100 m³ with reverberation of 0.5 seconds.
- These characteristics are for information only and are subject to change without advance.**

Electrical Data

MODELS		Size 30	Size 45
Power supply ~230 V - 50 Hz		*	*
VENTILATION			
Nominal current	A	0.9	0.96
Maximum current	A	1.27	1.35
Fuse rating aM*	A	2	2
Fuse rating ASE/VDE*	A	2	2
Cable section	mm ²	3G 1.5	3G 1.5
VENTILATION + ELECTRIC HEATING			
Nominal current	A	19.6	
Maximum current	A	23.7	
Fuse rating aM*	A	25	
Fuse rating ASE/VDE*	A	25	
Cable section	mm ²	3G 4	

MODELS		Size 30	Size 45
Power supply 3 N ~400 V - 50 Hz		*	*
VENTILATION + ELECTRIC HEATING			
Nominal current	A	7.4	8.8
Maximum current	A	8.5	10.6
Fuse rating aM*	A	10	16
Fuse rating ASE/VDE*	A	10	16
Cable section	mm ²	5G 1.5	5G 1.5

* These values are given for information only, they should be checked and adjusted according to standards in force : they depend on the mode of installation and the type of wires selected.

Condensate Pump

PUMP DATA		
Nominal voltage		1 ~ 230 V - 50 Hz
Power input	W	16
Current input	A	0.12
Waterflow max.	l/h	240
Max. manometric head	mWG	0.5

Electric Heating

The electric heating of the cassettes is composed of heating resistances placed inside the tubes of the heat exchanger.

These resistances are heat protected against any abnormal temperature rise by two thermostats equipped with a "positive safety" device (mechanical or thermic destruction of the capillary switches off the heating permanently) :

- a thermostat with automatic reset,
- a thermostat with manual reset.

Electric heating capacity

Power supply : 230 V - 50 Hz

Standard models	Size 30
Capacity	4300 W

Power supply : 3 N ~ 400 V - 50 Hz

Standard models	Size 30	Size 45
Capacity	4300 W	5400 W

Cooling Capacities

				Size 30 - 2-pipe			Size 45 - 2-pipe			Size 45 - 4-pipe		
				Air flow (m³/h)			Air flow (m³/h)			Air flow (m³/h)		
				LS	MS	HS	LS	MS	HS	LS	MS	HS
				1100	1350	1550	1000	1250	1630	1075	1360	1725
6/11 °C	27°C	Pt	W	6033	6819	7212	6967	8557	11130	7270	9214	11554
	47%	Ps	W	4505	4920	5120	5095	6315	8207	4911	6724	7994
	25°C	Pt	W	5176	5657	6196	6032	7425	9660	6424	8131	10165
	50%	Ps	W	4045	4341	4528	4515	5603	7598	4405	6028	7156
	23°C	Pt	W	3238	4483	4773	3770	5771	7545	5106	6480	8121
	50%	Ps	W	3093	3748	3925	3452	4862	6354	3858	5295	6297
7/12 °C	27°C	Pt	W	5600	6180	6440	6320	7840	10190	7149	8544	10100
	47%	Ps	W	4300	4630	4830	4800	5950	7750	4649	6367	7254
	25°C	Pt	W	4588	5195	5504	5393	6646	8649	5810	7351	9174
	50%	Ps	W	3774	4040	4230	4213	5233	6821	4125	5651	6697
	23°C	Pt	W	2903	3890	4168	3379	5017	6589	4571	5800	7265
	50%	Ps	W	2903	3469	3641	3251	4483	5877	3607	4950	5885
8/13 °C	27°C	Pt	W	4620	5155	5777	5681	6963	9069	6044	7659	9579
	47%	Ps	W	4029	4327	4521	4498	5578	7266	4358	5982	7113
	25°C	Pt	W	3260	4528	4812	3795	5850	7628	5181	6563	8214
	50%	Ps	W	3095	3752	3928	3454	4860	6346	3843	5273	6268
	23°C	Pt	W	2412	3396	3658	3044	3573	5734	4021	5108	6399
	50%	Ps	W	2412	3176	3341	3044	3573	5432	3358	4617	5501
10/15 °C	27°C	Pt	W	3707	4199	4484	4380	5425	7080	4881	6176	7723
	47%	Ps	W	3497	3771	3953	3904	4863	6358	3855	5287	6292
	25°C	Pt	W	2441	3183	3970	3023	3646	5758	4039	5123	6375
	50%	Ps	W	2441	3038	3352	3023	3646	5439	3351	4607	5469
	23°C	Pt	W	1986	2186	2881	2480	2922	3685	2877	3715	4750
	50%	Ps	W	1986	2130	2732	2480	2922	3685	2877	3715	4750

Pt : Total cooling capacity
Ps : Sensible cooling capacity

Heating Capacities

				Size 30 - 2-pipe			Size 45 - 2-pipe		
				Air flow (m³/h)			Air flow (m³/h)		
				LS	MS	HS	LS	MS	HS
				1100	1350	1550	1060	1360	1725
70/60 °C	19 °C	PC	W	13904	15727	18641	12981	16446	20288
	20 °C	PC	W	13567	15344	18186	12663	16042	19784
	21 °C	PC	W	13231	11960	17738	12348	15645	19292
EUROVENT				7000	7770	8050	7192	8927	11600
50/40 °C	19 °C	PC	W	7651	8638	10222	7100	8016	11171
	20 °C	PC	W	7324	8272	9784	6797	7676	10697
	21 °C	PC	W	7000	7900	9354	6496	7331	10218

PC : Heating capacity (W)

				Size 45 - 4-pipe		
				Air flow (m³/h)		
				LS	MS	HS
				1075	1360	1725
70/60 °C	19 °C	PC	W	6919	7924	9022
	20 °C	PC	W	6756	7737	8808
	21 °C	PC	W	6593	7551	8601
60/50 °C	19 °C	PC	W	5335	6110	6860
	20 °C	PC	W	5209	6020	6676
	21 °C	PC	W	5083	5873	6578
50/40 °C	19 °C	PC	W	3782	4317	4014
	20 °C	PC	W	3601	4134	4705
	21 °C	PC	W	3434	3949	4497

PC : Heating capacity (W)

Pressure Drops

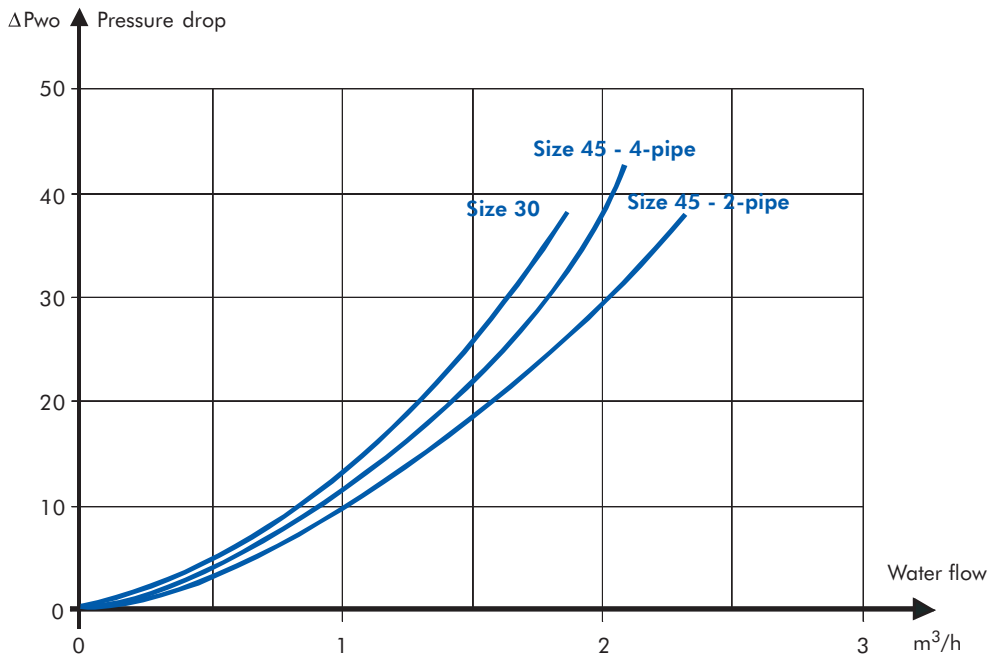

ΔP_{w0} : Pressure drops of pure water.
 ΔP_w : Pressure drops of brine water.
 ΔP_w : $K \times \Delta P_{w0}$.

T_{wm} (°C)	K : Glycol coefficient				
	% Glycol				
	10	20	30	40	50
3	1.135	1.234	1.385	1.53	1.85
5	1.13	1.23	1.38	1.51	1.77
10	1.12	1.22	1.37	1.47	1.66
15	1.11	1.19	1.36	1.46	1.64
20	1.1	1.18	1.35	1.44	1.59
25	1.09	1.17	1.33	1.43	1.57
30	1.08	1.16	1.31	1.42	1.56
35	1.07	1.15	1.29	1.41	1.54
40	1.06	1.14	1.28	1.4	1.52
45	1.05	1.13	1.25	1.37	1.49
50	1.04	1.12	1.22	1.34	1.47
55	0.99	1.1	1.2	1.31	1.44
60	0.94	1.09	1.19	1.28	1.42

T_{wm} : Average temperature of the mixture.

T_{se} (°C)	% Glycol				
	10	20	30	40	50
-25					yes
-20				yes	yes
-15				yes	yes
-10			yes	yes	yes
-5		yes	yes	yes	yes
0	yes	yes	yes	yes	yes
5	yes	yes	yes	yes	yes

T_{se} : Outdoor dry temperature.

Pressure drops at nominal flow (pure water)

		Size 30	Size 45 - 2-pipe	Size 45 - 4-pipe
Nominal flow	m^3/h	1.206	1.753	1.89
ΔP	kPa	17	23.5	34.3

Field of Operation

Using chilled water

Indoor temperature	°C	Thi	13	MINIMUM TEMPERATURE
		Tsi	17	
Cooling water	°C	Twe	3	
Indoor temperature	°C	Thi	22	MAXIMUM TEMPERATURE
		Tsi	32	
Cooling water	°C	Tse	18	

Using hot water (electric heating forbidden)

Maximum indoor temperature	°C	Thi	22
		Tsi	32
Maximum entering water temperature	°C	Twe	60

Characteristics

Models		30	45
Contents	l	2.7	4
Max. pressure of operation	bar	15	15
Testing pressure	bar	24	24
Couplings - 2-pipe	inch	1" gas male	1" gas male
	mm	26-34 male	26-34 male
Couplings - 4-pipe	inch	-	1" gas male (Cooling) 1/2" gas male (Heating)
	mm	-	26-34 male (Cooling) 15-21 male (Heating)

- Thi** : Indoor wet bulb.
Tsi : Indoor dry bulb.
Tse : Outdoor dry bulb.
Twe : Entering water temperature.

Fresh Air Intake

Fresh air flow should not exceed 12% of nominal air flow (See table hereunder).

NOTE : An anti-frost thermostat preset at +5 °C, installed on site on fresh air intake is mandatory for winter application. A filter, fan and insulated air duct (not supplied) are to be installed on site.

Treated air discharge in an adjacent room

In case of discharge towards an adjacent room, provide for decompression toward the air return of the treatment unit.

Models		Size 30	Size 45
Nominal air flow (HS)	m ³ /h	1530	1630
Maximal fresh air flow	m ³ /h	86	90

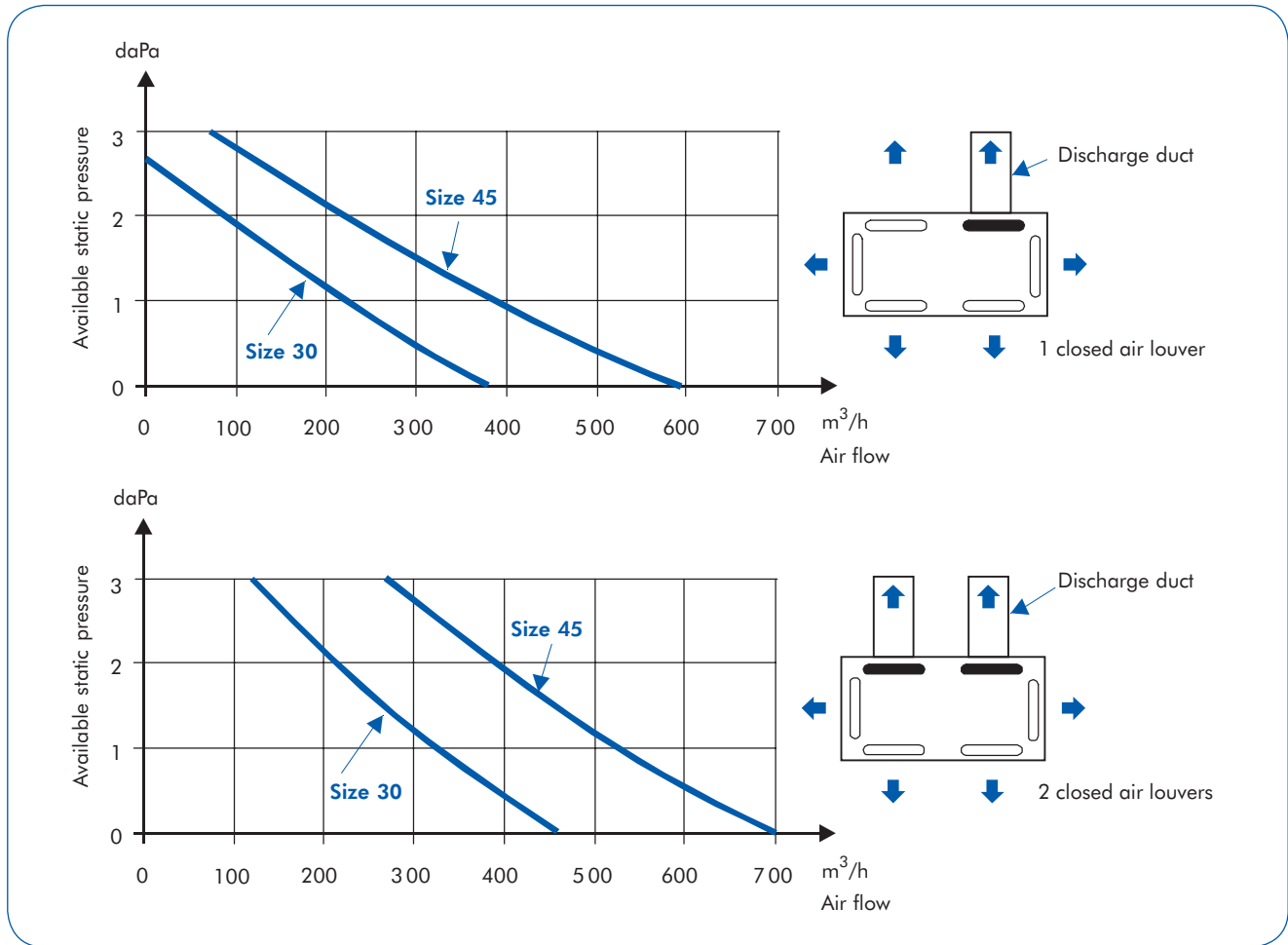

Dimensions

2-pipe units

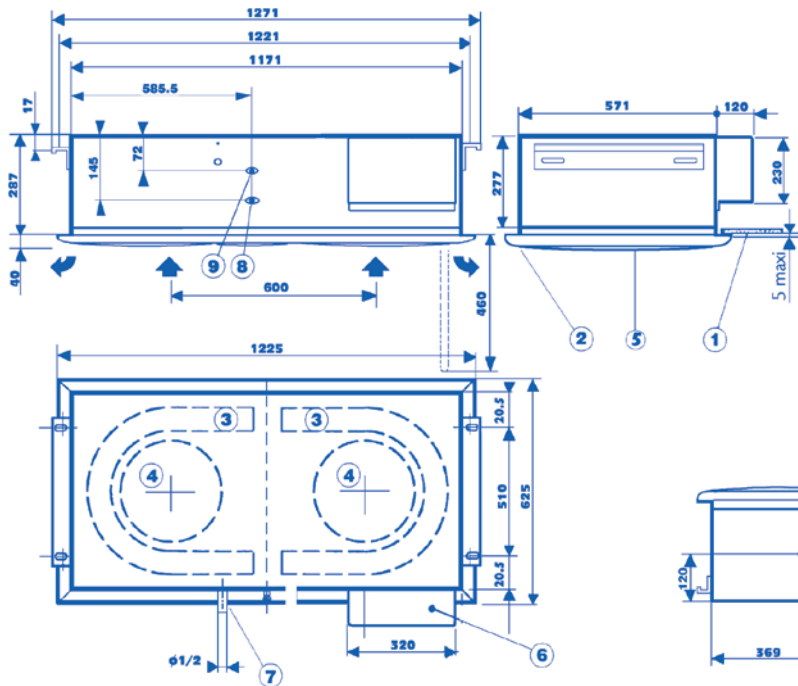

DESCRIPTION	
8	Water inlet connection (G1")
9	Water outlet connection (G1")

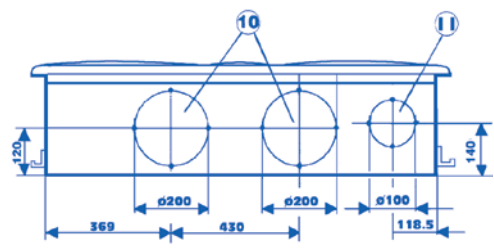

4-pipe units

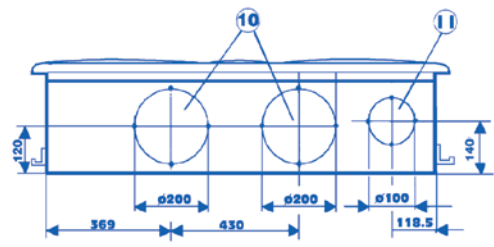
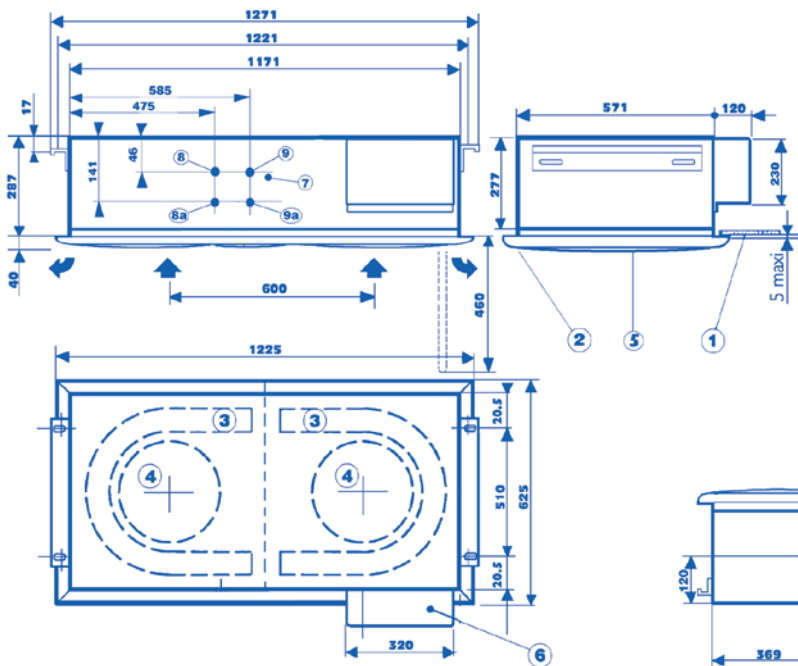

DESCRIPTION			
1	False ceiling	8	Hot water outlet connection (G1/2")
2	T-shaped rod (false ceiling)	8a	Hot water inlet connection (G1/2")
3	Heat exchanger	9	Chilled water outlet connection (G1")
4	Fan	9a	Chilled water inlet connection (G1")
5	Suction grille	10	Port to distribute air through a duct into a neighbouring room (pre-punched)
6	Electric box (removable)	11	Port to suction fresh air (pre-punched)
7	Draining of condensates ($\phi 1/2"$)		

3-Way Valve with By-pass

The kit three-way valve with by-pass allows to control "all or nothing" of a cassette when operating chilled water mode or hot water mode.

This kit includes a three-way valve with by-pass controlled by an electric servomotor.

Motorized 3-way valve with by-pass

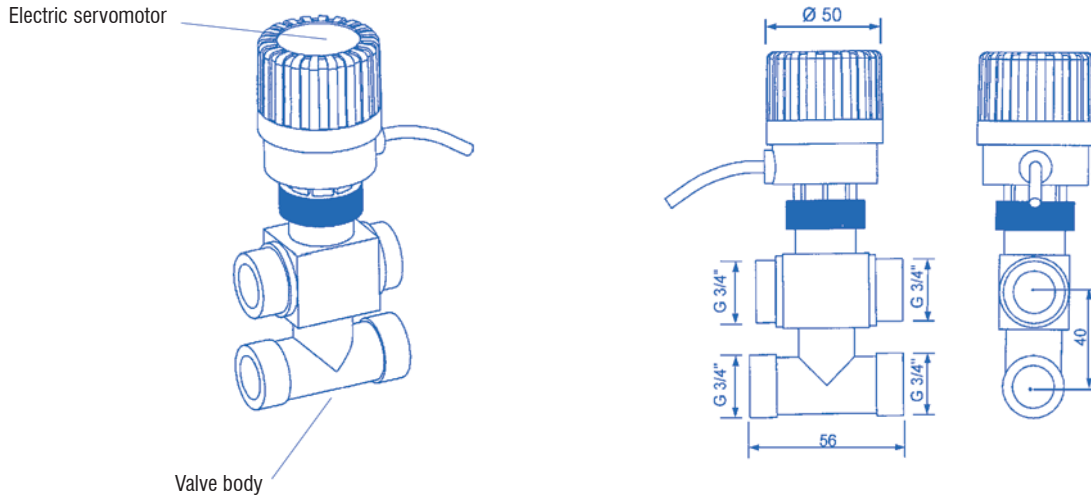

Condensate tray for 3-way valve

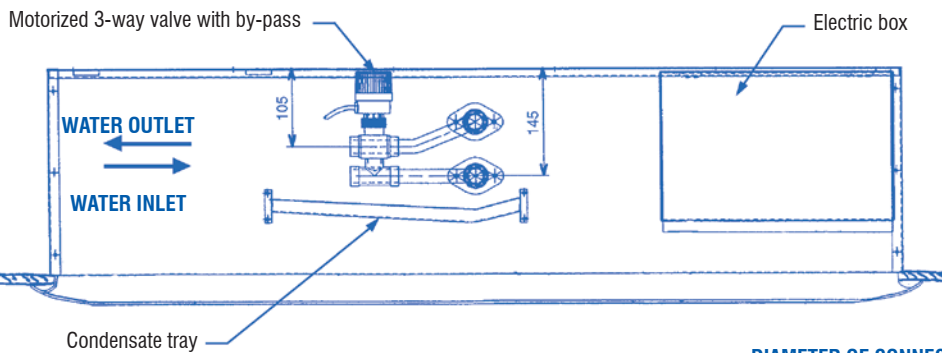
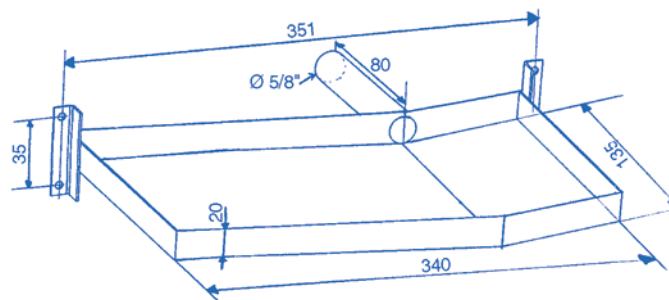

DIAMETER OF CONNECTION

Models	Size 30	Size 45
Water inlet	G 3/4" Male 20-27	
Water outlet	G 3/4" Male 20-27	

Electrical Wiring Diagrams - Standard Wiring for 2-pipe Cassettes

MODEL	MAX	MED	MIN
30	YE	BN	OG
45	GY	BU	OG

MP PUMP CONDENSATE MOTOR
 MV FAN MOTOR THERMALLY PROTECTED
 CV CAPACITOR
 KRX DEFAULT RELAY
 FV VARISTOR
 SB WATER LEVEL SENSOR
 YF COLD ELECTROVALVE (KIT)
 AL..13 15 PINS CONNECTOR
 X TERMINAL STRIP
 MAX HIGH SPEED
 MED MEDIUM SPEED
 MIN LOW SPEED
 QG GENERAL PROTECTION (not fitted)

MP MOTEUR POMPE CONDENSAT
 MV MOTEUR VENTILAT. PROTEGE THERMIQ.
 CV CONDENSATEUR
 KRX RELAIS DEFAULT
 FV VARISTANCE
 SB CAPTEUR DE NIVEAU D'EAU
 YF ELECTROVANNE FROID (KIT)
 AL..13 CONNECTEUR 15 POINTS
 X BORNIER DE RACCORDEMENT
 MAX GRANDE VITESSE
 MED MOYENNE VITESSE
 MIN PETITE VITESSE
 QG PROTECTION (non fournie)

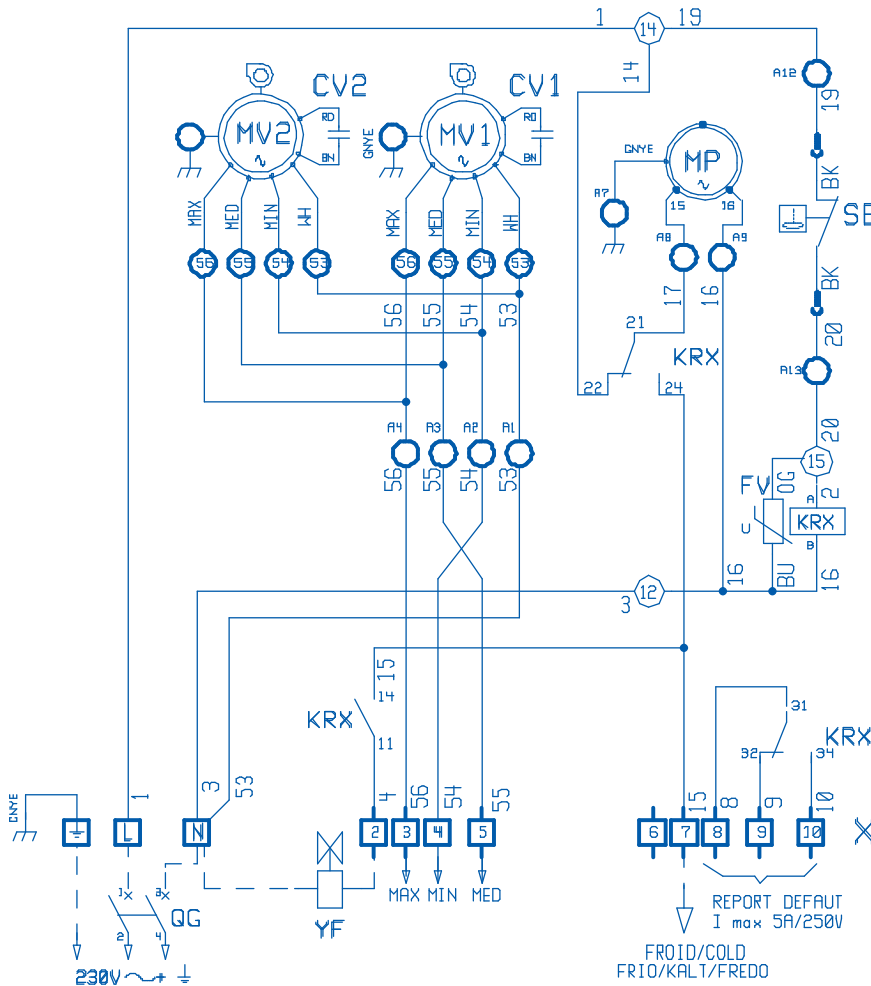

BK	NEGRO	BLACK	NERO
BN	MARRON	BROWN	MARRONE
BU	AZUL	BLUE	BLU
GNYE	VERDE/AMAR.	GREEN/YELL.	VERDE/GIALLO
GY	GRIS	GREY	GRIGIO
OG	NARANJA	ORANGE	ARANCIONE
RD	ROJO	RED	ROSSO
VT	VIOLETA	VIOLET	VIOLETA
WH	BLANCO	WHITE	BIANCO

BK	SCHWARZ	NOIR
BN	BRÄUN	BRUN
BU	BLAU	BLEU
GNYE	BRUN/GELB	VERT/JAUNE
GY	GRAU	GRIS
OG	ORANGE	ORANGE
RD	ROT	ROUGE
VT	VIOLETT	VIOLET
WH	HEISS	BLANC

**The electrical wiring diagram can be modified without advance notice.
 Always refer to the diagram supplied with the unit.**

Electrical Wiring Diagrams - Standard Wiring for 4-pipe Cassettes

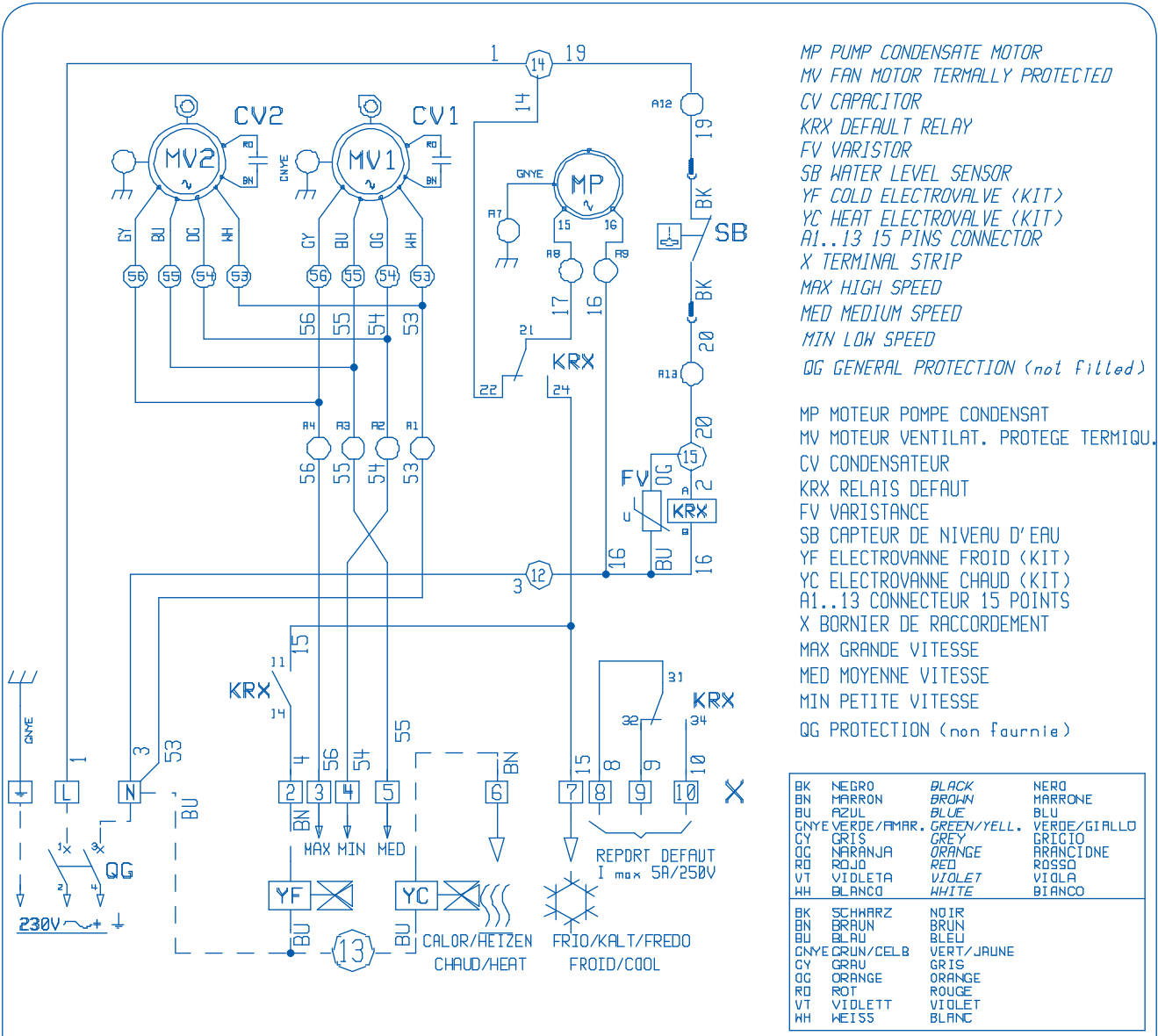

**The electrical wiring diagram can be modified without advance notice.
 Always refer to the diagram supplied with the unit.**

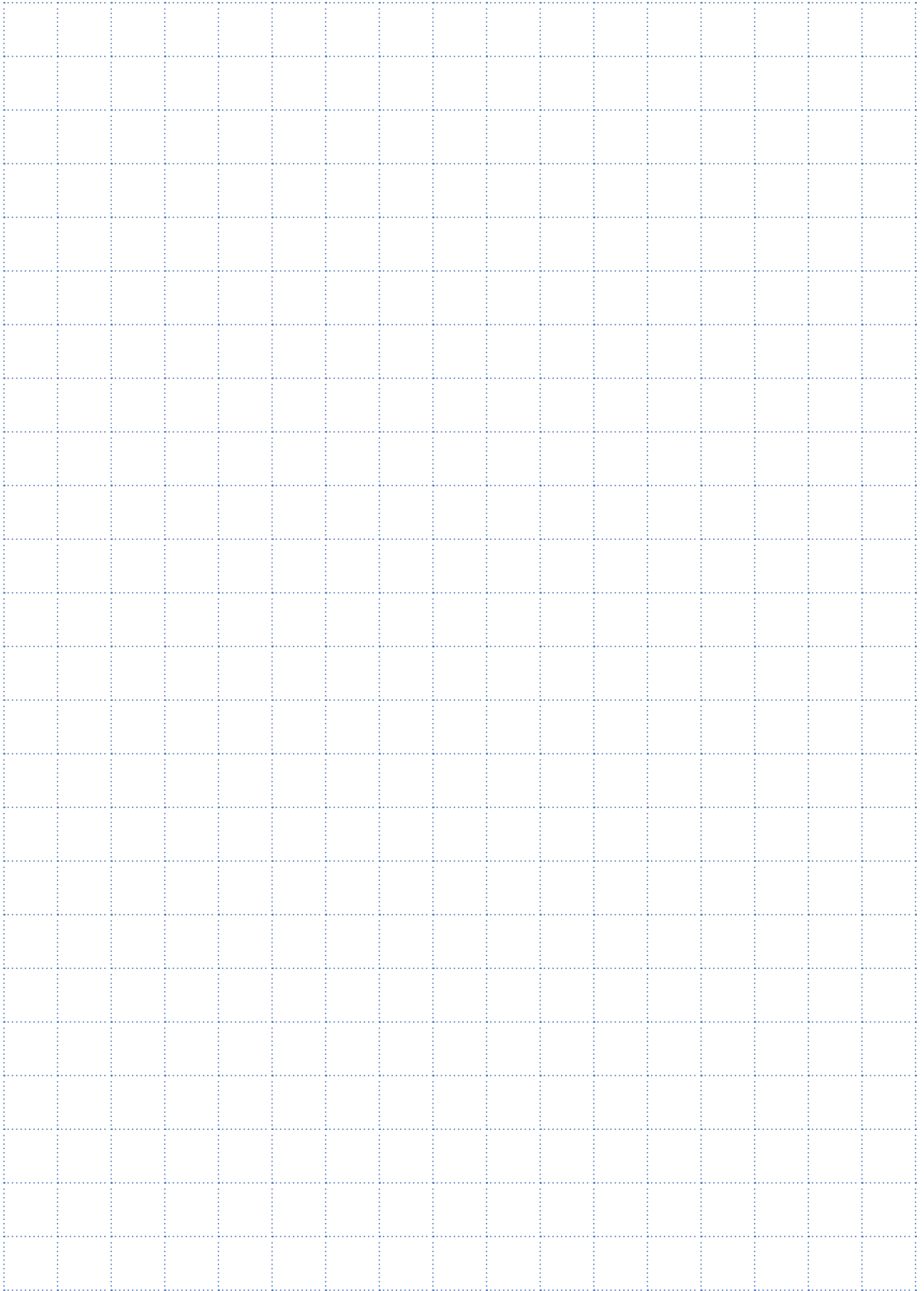

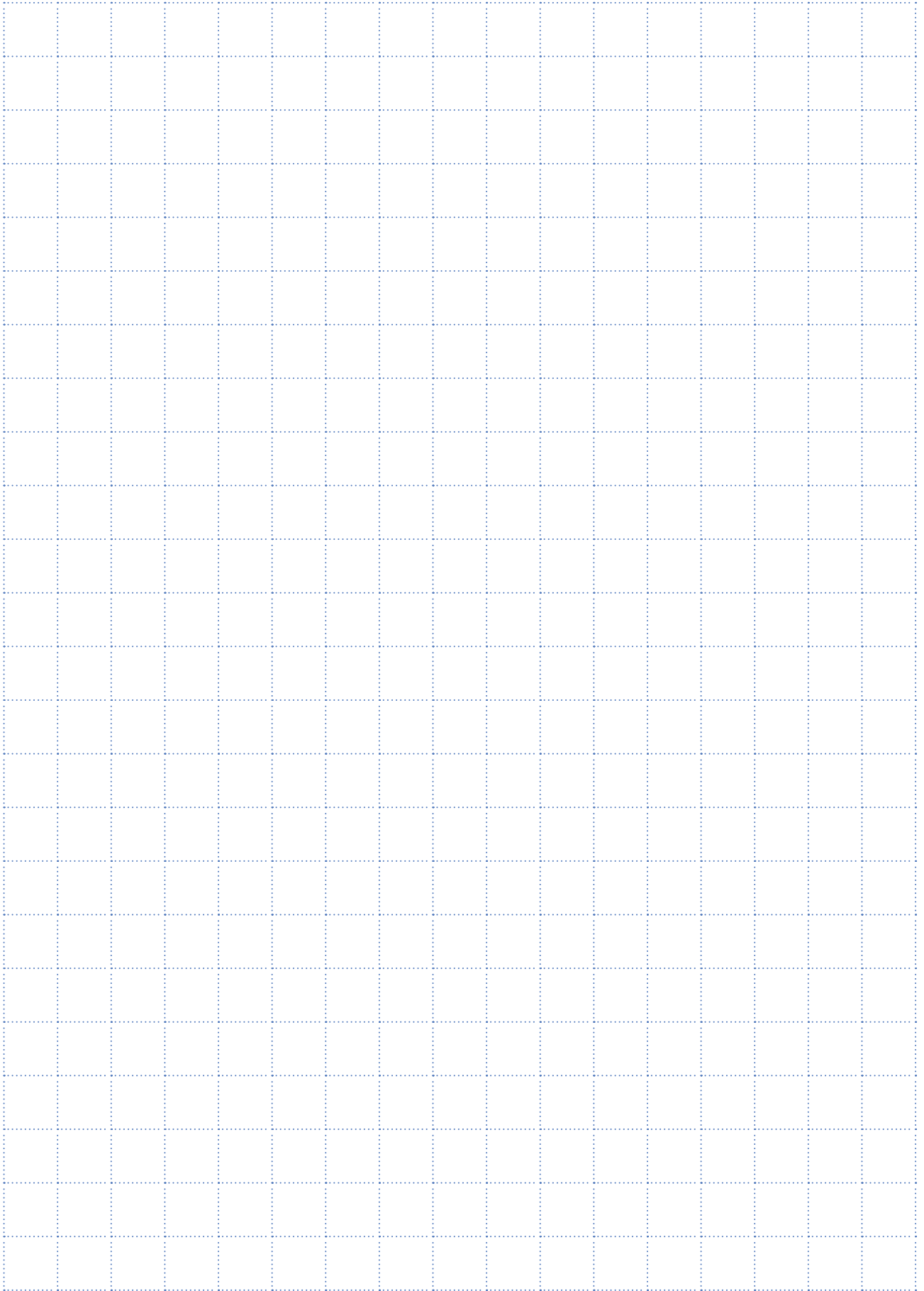



AIRWELL France SAS
1bis, Avenue du 8 mai 1945
Saint Quentin en Yvelines
78284 GUYANCOURT
France
Tél. +33 (0) 01 39 44 78 00
Fax +33 (0) 01 39 44 65 17

Ref. : EDM KOG2-A.3GB/06.09 - Supersedes : EDM KOG2-A.2GB/06.07

As part of our ongoing product improvement programme, our products are subject to change without prior notice. Non contractual photos.