

VH

High Static Pressure Ductable
Fan Coil Unit

New : available with EC motor

Models 03 to 27

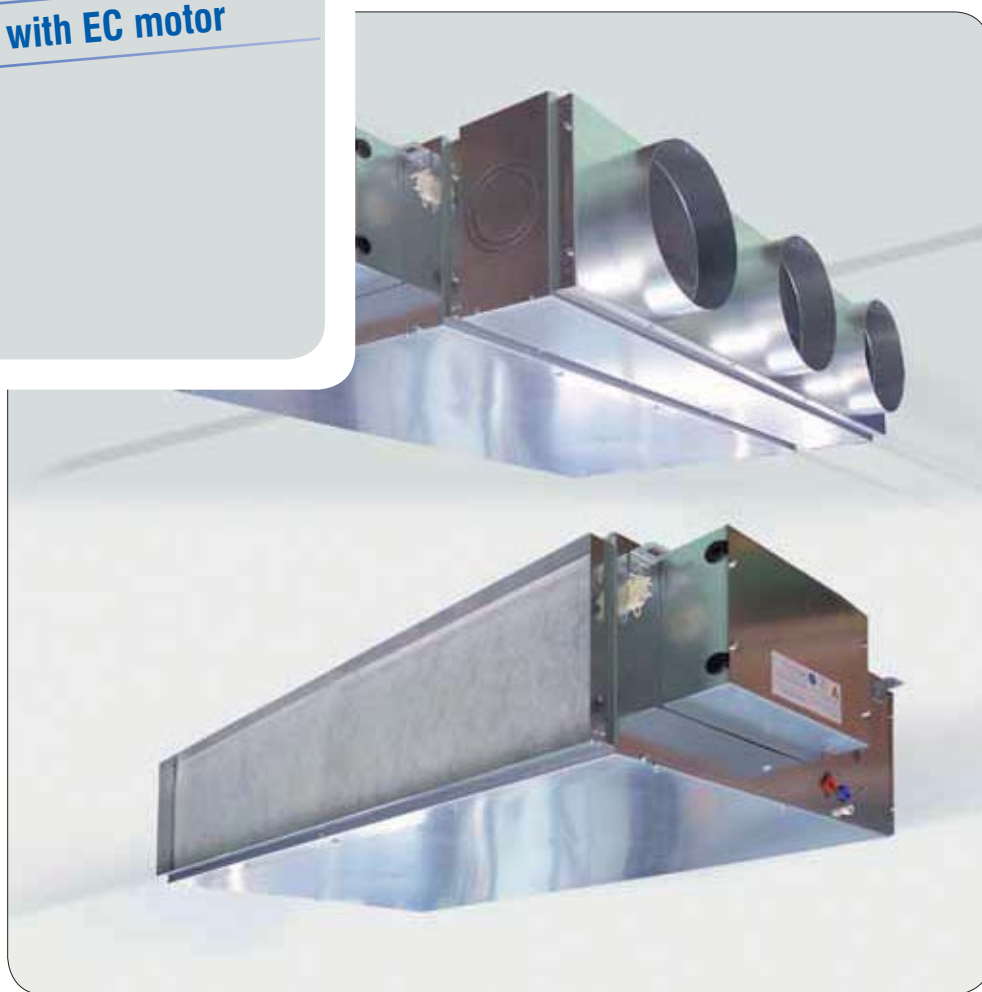

200 to 4650 m³/h

General Characteristics

Presentation

The new ducted high static pressure fan coil units VH have been designed to replace the two ranges VHF and VH2N, and give the following advantages :

- Single range,
- Configuration flexibility thanks to a modular conception,
- Filter offer with more important efficiencies (G3 and G4),
- Significant energy savings thanks to EC motor offer,
- Better acoustic performances in low speed operation,
- Thermal performances identical to the VHF and VH2N ranges,
- Dimensions reduced and low embedding height,
- ERP option for certain European market.

The **VH** range is specially designed to meet the job requirements that call for false-ceiling installations and for air distribution by ductwork requiring high static pressure (up to 220 Pa for larger units).

Composed of **9 models** (VH03,05,07,10,15,18,21,24 and 27) to ensure air flows up to **4650 m³/h**.

In order to meet your applications, the **VH** range is available in 2-pipe, 2 tubes réversibles, 2-pipe/2-wire, 2 tubes réversibles/2-wire and 4-pipe systems.

Different types of configurations

The VH models are available in **three configurations** :

- With rectangular return and rectangular discharge duct connections as a whole part of the unit casing,
- With rectangular return and circular or oblong discharge duct connections,
- With circular or oblong return and circular or oblong discharge duct connections.

The circular or oblong duct connections are provided with 2 or 3 circular (160, 200 or 250 mm diameter) or oblong (250 mm equivalent diameter) connecting collars according to the unit sizes (VH 03 to 10).

The discharge duct connection is insulated with 10 mm thick closed cell polyethylene foam having M1 fire classification.

Casing

Fabricated from 1.0 mm thick galvanized sheet steel with the fixing brackets located at the top part of the casing for installation to the ceiling.

The condensate drain pan is made from 1.0 mm thick galvanized sheet steel, painted and is externally insulated by 2 mm thick closed cell polyethylene foam, having M1 fire classification.

An optional auxiliary drain pan can be provided to collect condensates from coils headers.

Access to internal components (fan-motor assembly and coils) for service and maintenance works is facilitated by dismantling the central bottom panel of the fan coil unit, without removing the distribution ducts.

The hydraulic and electrical connections can be carried out at the same service side or at the opposite service side.

Fixation

The unit is supplied with 4 slotted fixing brackets as standard.

Coil compartment

It is lined with 10 mm thick closed cell polyethylene foam insulation, having M1 fire classification.

It incorporates water coils which are fitted with 1/2"Ø female threaded couplings for models VH 03 to 10 and with Rc 3/4" to Rc 1"1/4 male threaded couplings for larger units.

The coils used in VH range have, according to the unit sizes, different number of rows as stated below :

- 3 rows (2-pipe system) and 2+1 rows (4-pipe system) for VH 15,
- 4 rows (2-pipe system) and 3+1 rows (4-pipe system) for VH 03, 05, 07, 18 & 24,
- 5 rows (2-pipe system) and 4+1 rows (4-pipe system) for VH 10, 21 & 27.

Coils are leak tested under water (21 bar) and are suitable for a maximum working pressure of 10 bar.

Fan compartment

It incorporates a fan-motor assembly of which the fan is composed of double inlet forward curved type aluminium wheels and galvanized sheet steel scrolls.

The **VH** range can be supplied with **2 types of motor** :

- The **standard motor** available on all sizes, is of direct drive type having 4, 5 or 6 speeds (3 speeds pre-wired) according to the models. The motor is suitable for nominal voltage of 230 V / 1 Ph / 50-60 Hz and is equipped with a built-in thermal overload protection of automatic reset type.
- The **EC motor** available on VH 03 to 10, is of high efficiency and low electrical consumption type for a significant energy saving. The motor is suitable for 0-10V input, ensuring variable speed capability. It is fitted with Ecospeed3 interface card (supplied as standard) for a 3-speed optimized running.

Relays for fan speed control are fitted, as standard, on VH 15/18/21/24/27.

Options and accessories

→ Air filter :

Filter consists of cleanable synthetic media (sewn on wire frame), having **G3 or G4** classification.

Filter is removable and is easily pulled out downward for cleaning or replacement, after removing the access metal plate.

→ Electric heater for 2-pipe/2-wire system :

Electric heater consists of heating rod type resistances equipped with a manual reset and an automatic reset high temperature cutout switches. The electric heater On/Off control, made thanks to a relay, can be mounted as optional.

Standard voltage is single phase 230 V.

→ Fresh air intake and plenum :

The fresh air plenum is supplied as standard in case of configuration with circular or oblong return duct connection.

The intake of fresh air can be assured by a pre-cut opening of Ø 100 mm or 125 mm (VH 03 to 10, but Ø 100 mm only on VH 03), Ø 160 mm (VH 15 to 21) or Ø 200 mm (VH 24 & 27) located at left or right side of fresh air plenum.

→ Regulation valves :

On/Off (thermal type actuator), 2-way or 4-way type for 2-pipe or 4-pipe systems.

Valves are not available for model VH 27. Valves for models VH 03/05/07/10 are supplied mounted, those for models VH 15/18/21/24 are supplied loose.

→ Controls :

TRM, TAE, Aqu@Simp or Aqu@Net.

→ Condensate pump :

Supplied fitted on VH03 to 10, loose on VH 15 to 27.

→ Fuse holder :

A fuse holder with fuse can be supplied as optional to protect the unit.

→ MO insulation :

For ERP (Building Receiving the Public) applications, the VH range can be equipped as optional with a MO fire classification internal insulation.

VH Advantages

Improvement of acoustical performances - Example of a VH 07 in low speed

Thanks to the choice of a new fan-motor assembly, an acoustical gain of 5.5 dB in low speed is obtained on certain models.

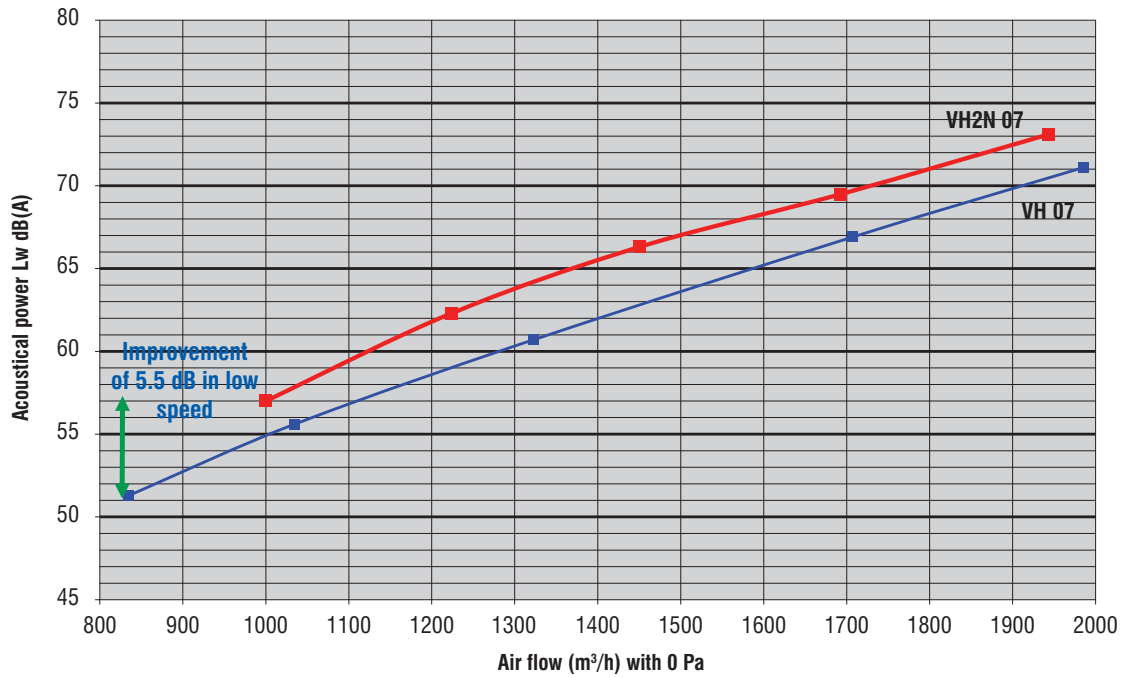

Energy savings with EC motor - Example of a VH 07

With the use of EC motor (optional), an important reduction of the consumed power can be realized.

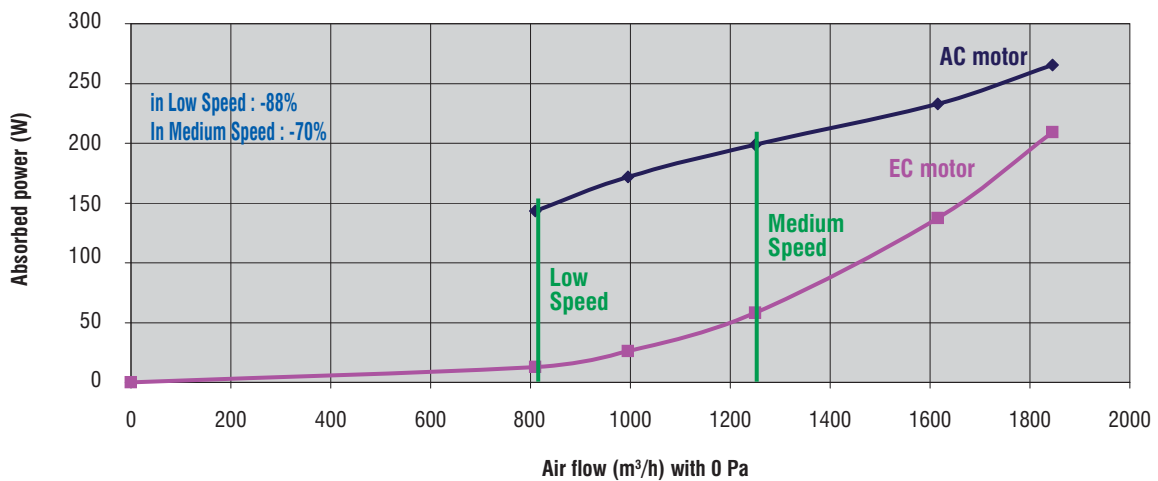

3-speed control interface for EC motor :

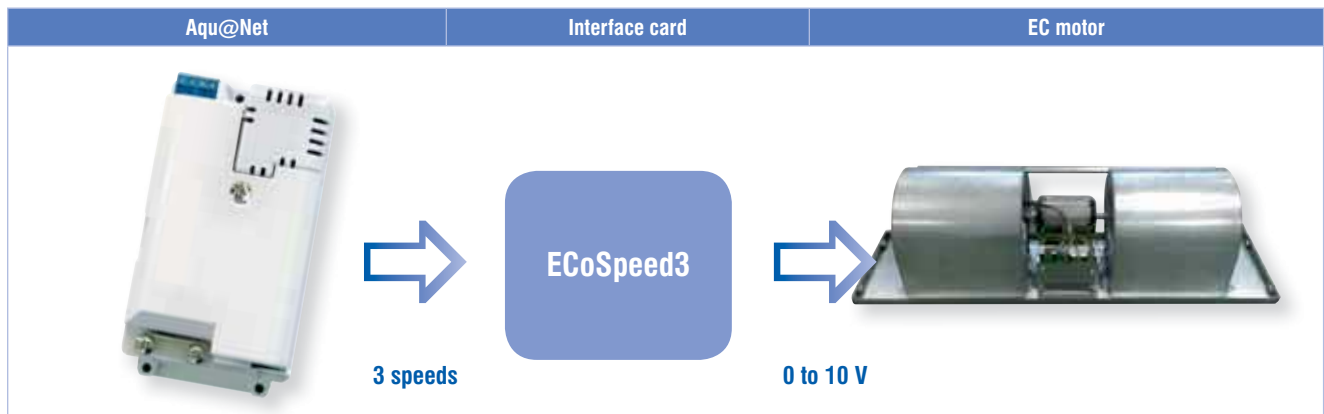

EC motor/AC motor Absorbed Power Comparison

VH 03

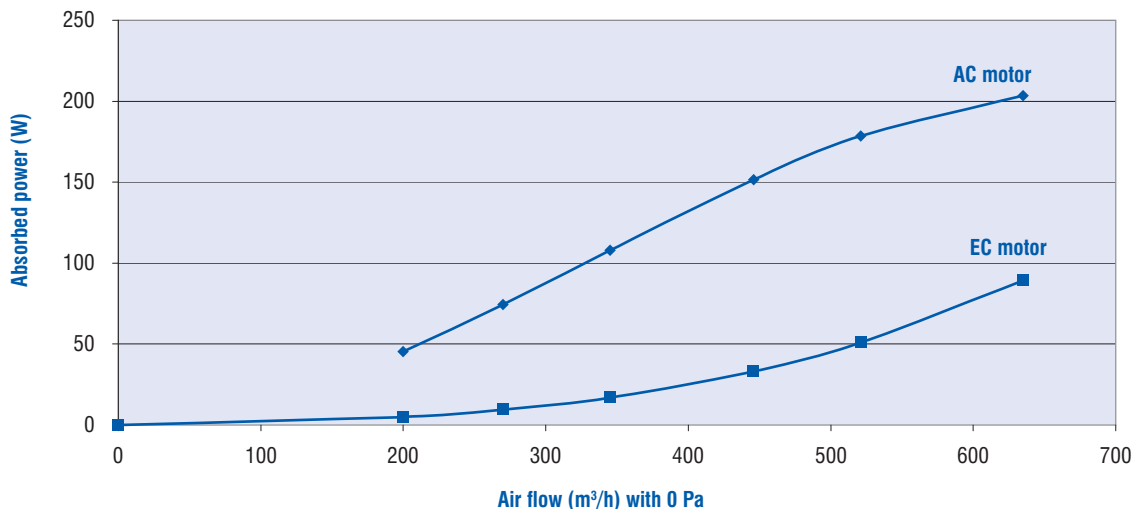

Air flow (m³/h)	AC motor absorbed power (W)	EC motor absorbed power (W)
0		0
200	46	5
270	74	9
345	108	17
446	151	33
521	179	51
635	203	89

VH 05

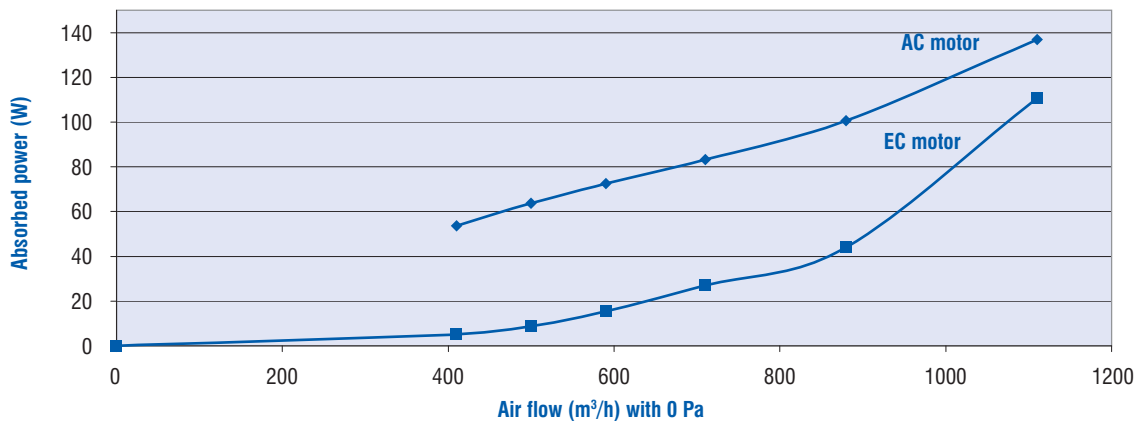

Air flow (m³/h)	AC motor absorbed power (W)	EC motor absorbed power (W)
0		0
410	54	5
500	64	9
590	72	15
710	83	27
880	101	44
1110	137	111

EC motor/AC motor Absorbed Power Comparison (continued)

VH 07

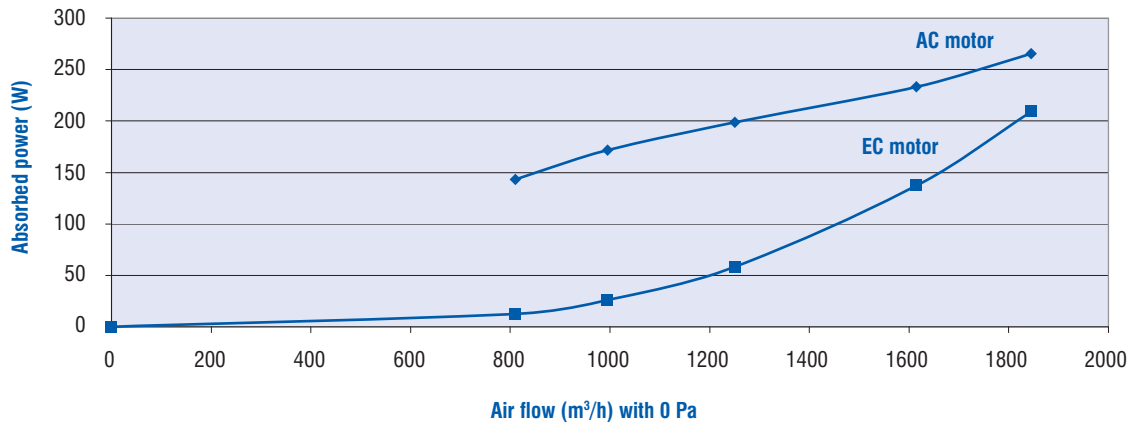

Air flow (m³/h)	AC motor absorbed power (W)	EC motor absorbed power (W)
0	0	0
810	143	13
995	172	26
1250	199	58
1615	233	137
1845	265	209

VH 10

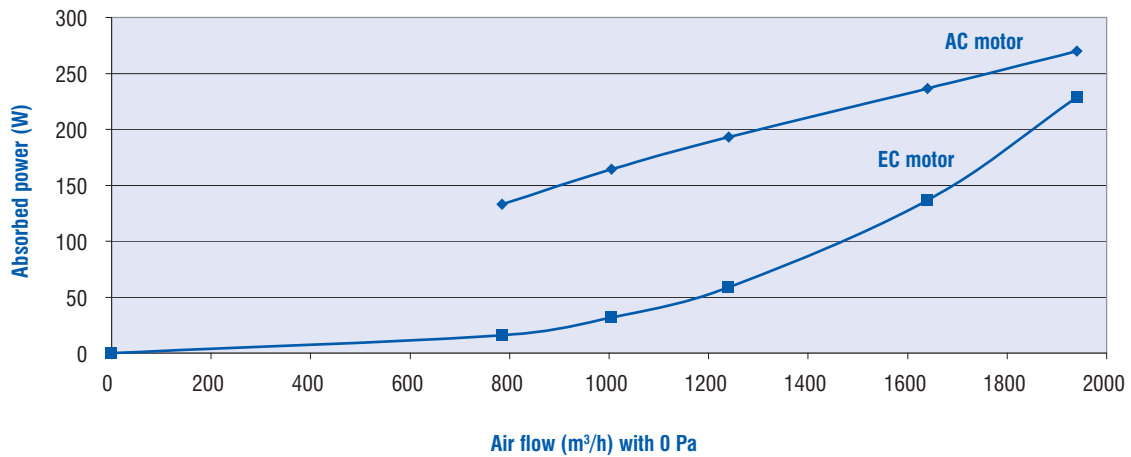

Air flow (m³/h)	AC motor absorbed power (W)	EC motor absorbed power (W)
0	0	0
785	133	16
1005	164	32
1240	193	59
1640	237	137
1940	270	229

Note : Data given for a configuration with G3 filter and rectangular duct connections.

Operating Limits of VH 03 to 10 with EC Motor

VH 03

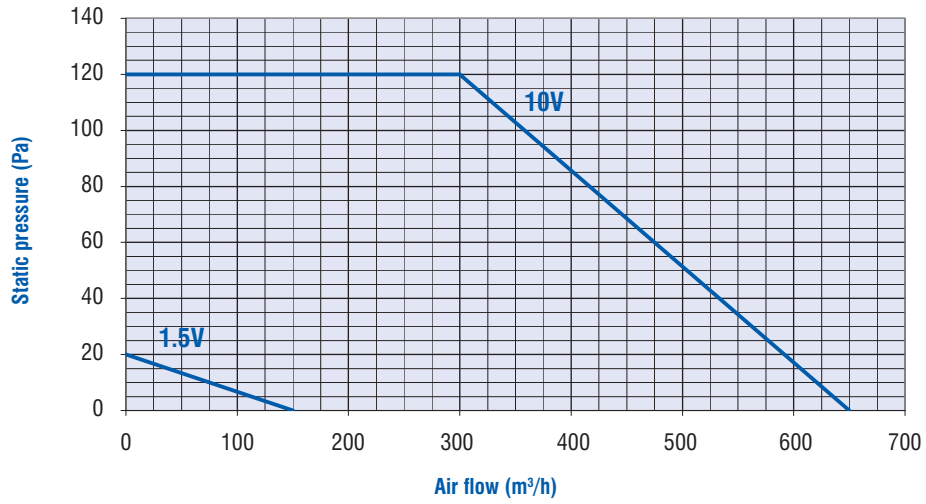

VH 05

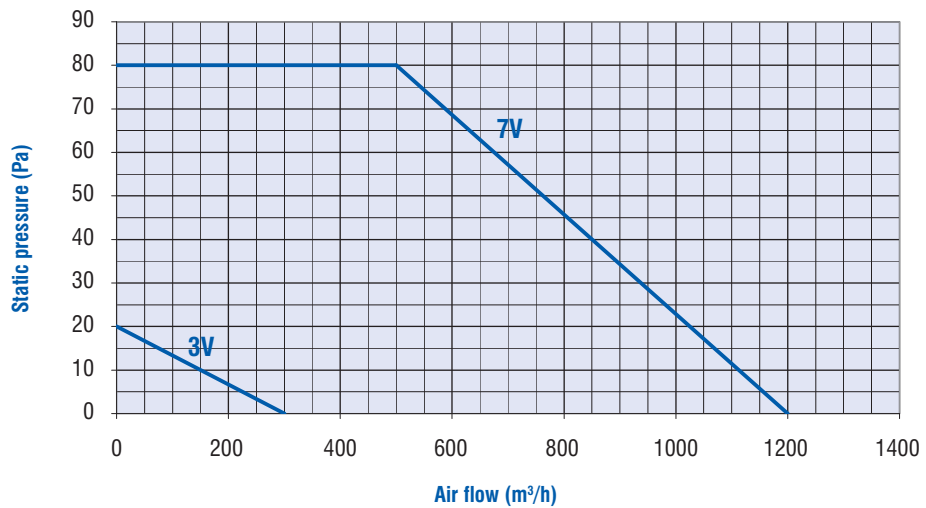

VH 07 & 10

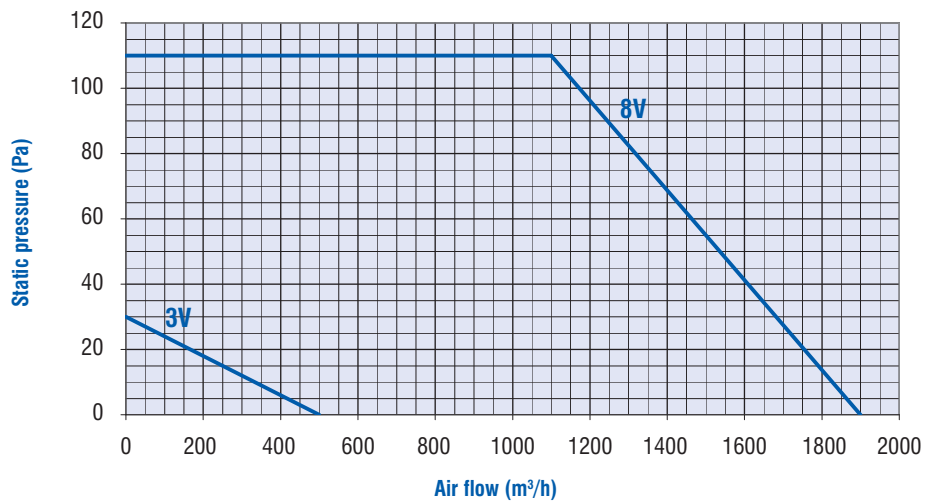

Standard Motor Electrical Data

Sizes		VH 03		VH 05		VH 07		VH 10	
		Absorbed current (A) (1)	Absorbed power (W) (1)	Absorbed current (A) (1)	Absorbed power (W) (1)	Absorbed current (A) (1)	Absorbed power (W) (1)	Absorbed current (A) (1)	Absorbed power (W) (1)
Fan speed	V1	0.19	42	0.24	53	0.66	132	0.68	136
	V2	0.31	70	0.28	61	0.75	163	0.78	165
	V3	0.46	104	0.31	69	0.82	182	0.90	195
	V4	0.65	147	0.35	77	0.88	201	1.02	225
	V5	0.76	172	0.41	91	0.98	222	1.12	250
	V6	0.92	207	0.58	120				

(1) Absorbed current and absorbed power data given for a motor operating with 230V/1Ph/50Hz power supply, non ducted unit with 0 Pa external static pressure and G3 filter. Inlet and outlet of duct circular.

Sizes		VH 15		VH 18		VH 21		VH 24		VH 27	
		Absorbed current (A) (2)	Absorbed power (W) (2)	Absorbed current (A) (2)	Absorbed power (W) (2)	Absorbed current (A) (2)	Absorbed power (W) (2)	Absorbed current (A) (2)	Absorbed power (W) (2)	Absorbed current (A) (2)	Absorbed power (W) (2)
Fan speed	V1	0.93	180	0.93	180	0.93	180	2.00	420	2.00	420
	V2	1.33	271	1.33	271	1.33	271	2.40	530	2.40	530
	V3	2.00	421	2.00	421	2.00	421	3.00	673	3.00	673
	V4	2.52	587	2.52	587	2.52	587	3.85	870	3.85	870
	V5	3.17	675	3.17	675	3.17	675				

(2) Absorbed current and absorbed power data given for a motor operating with 230V/1Ph/50Hz power supply, non ducted unit with 0 Pa external static pressure and G3 filter. Inlet and outlet of duct rectangular.

EC Motor Electrical Data

VH03 : Max = 10V		VH05 : Max = 7V		VH07 : Max = 8V		VH10 : Max = 8V	
Max absorbed current (A)	Max absorbed power (W)	Max absorbed current (A)	Max absorbed power (W)	Max absorbed current (A)	Max absorbed power (W)	Max absorbed current (A)	Max absorbed power (W)
0.75	89	0.85	111	1.55	209	1.67	229

Electric Heating Coil Data

Sizes		VH 03	VH 05	VH 07 / VH 10	VH 15 / VH 18 / VH 21	VH 24 / VH 27
Capacity (W)	BE1	600	500	1000	1000	1000
	BE2	800	750	1500	2000	2000
	BE3	1200	1000	2000	3000	3000
	BE4	1400	1500	-	-	-
	BE5	1600	2000	-	-	-

Coil Water Volume

Sizes	Water volume (in litres)			
	2-pipes	4-pipes		Heating
		Cooling		
VH 03	0.9	0.8		0.2
VH 05	1.9	1.6		0.5
VH 07	2.3	1.9		0.6
VH 10	4.2	3.2		1.1
VH 15	3.7	3.1		1
VH 18	5.4	3.7		1.7
VH 21	6.5	5.2		1.7
VH 24	7	5.8		1.7
VH 27	8.9	7.3		1.9

Sound Power Levels Lw in dB(A) - VH 03

Speeds	Type	Acoustical power per octave band (dB(A))						Lw global dB(A)	Lp global dB(A) (3)	NR (3)
		125Hz	250Hz	500Hz	1kHz	2kHz	4kHz			
V1	Return + Radiated (1)	30.0	35.6	36.0	35.8	29.9	17.1	41.3	20.3	15
	Discharge (1)	29.6	34.1	30.5	34.3	32.2	13.4	39.5		
	Radiated (2)	19.4	25.5	27.2	27.5	21.6	13.5	32.3		
V2	Return + Radiated (1)	34.6	42.3	42.6	44.9	40.8	28.7	49.1	28.1	24
	Discharge (1)	34.8	40.1	38.3	41.7	41.2	26.2	46.9		
	Radiated (2)	30.9	32.3	34.8	37.2	31.9	17.3	41.1		
V3	Return + Radiated (1)	38.8	48.3	48.1	52.6	49.4	40.3	56.2	35.2	31
	Discharge (1)	40.1	46.3	45.2	51.0	49.4	38.6	54.9		
	Radiated (2)	30.4	38.5	40.0	45.1	40.3	30.7	48.0		
V4	Return + Radiated (1)	42.5	52.3	53.4	58.5	56.8	48.5	62.2	41.2	37
	Discharge (1)	45.7	52.4	51.9	57.2	55.6	46.4	61.2		
	Radiated (2)	34.5	44.3	46.1	51.4	48.1	40.4	54.5		
V5	Return + Radiated (1)	45.8	54.9	56.1	60.8	60.4	52.4	65.1	44.1	41
	Discharge (1)	48.0	55.5	55.0	60.2	59.2	50.7	64.4		
	Radiated (2)	37.4	46.5	48.5	53.0	51.0	43.6	56.7		
V6	Return + Radiated (1)	52.3	56.9	62.5	63.9	63.6	55.9	68.8	47.8	44
	Discharge (1)	50.7	58.9	58.5	62.7	64.0	54.1	68.0		
	Radiated (2)	39.6	48.5	50.7	54.4	54.0	46.5	58.9		

- (1) According Eurovent 8/2, data given for a unit with :
- 50 Pa external static pressure in medium speed (V3),
 - circular return and discharge,
 - G3 standard filter.
- (2) Data given for a unit with :
- 50 Pa external static pressure in medium speed (V3),
 - circular return and discharge,
 - ducted return and discharge (1.5 m),
 - G3 standard filter.
- (3) Informative data, considering an hypothetical sound attenuation of the room and installation of 21dB.

Sound Power Levels Lw in dB(A) - VH 05

Speeds	Type	Acoustical power per octave band (dB(A))						Lw global dB(A)	Lp global dB(A) (3)	NR (3)
		125Hz	250Hz	500Hz	1kHz	2kHz	4kHz			
V1	Return + Radiated (1)	39.4	41.7	42.0	41.6	40.4	31.6	48.2	27.2	21
	Discharge (1)	41.9	39.9	41.9	40.5	35.1	23.8	47.4		
	Radiated (2)	35.9	34.5	35.4	34.3	29.9	20.3	41.4		
V2	Return + Radiated (1)	42.2	44.5	44.8	44.8	44.0	35.6	51.3	30.3	25
	Discharge (1)	43.5	42.5	44.7	44.1	40.0	27.9	50.2		
	Radiated (2)	37.6	37.2	38.3	37.9	33.5	26.5	44.3		
V3	Return + Radiated (1)	43.5	46.5	46.7	46.8	46.2	38.4	53.2	32.2	27
	Discharge (1)	44.3	44.3	46.5	46.1	42.3	30.7	52.0		
	Radiated (2)	37.4	39.2	39.9	39.4	35.5	28.2	45.6		
V4	Return + Radiated (1)	44.9	47.9	48.1	48.4	48.3	40.6	54.9	33.9	29
	Discharge (1)	45.2	45.9	48.0	48.2	44.4	33.4	53.7		
	Radiated (2)	40.0	39.8	41.0	40.8	37.4	30.3	47.0		
V5	Return + Radiated (1)	46.2	49.6	49.2	50.0	50.0	42.6	56.4	35.4	31
	Discharge (1)	46.5	47.9	49.7	50.2	46.8	35.9	55.5		
	Radiated (2)	38.7	41.9	42.4	42.2	39.2	32.4	48.2		
V6	Return + Radiated (1)	48.2	51.0	50.5	51.2	51.2	44.1	57.7	36.7	32
	Discharge (1)	50.0	49.6	51.4	52.2	48.7	38.2	57.6		
	Radiated (2)	40.6	43.2	43.8	43.7	40.9	34.4	49.8		

- (1) According Eurovent 8/2, data given for a unit with :
- 50 Pa external static pressure in medium speed (V3),
 - circular return and discharge,
 - G3 standard filter.
- (2) Data given for a unit with :
- 50 Pa external static pressure in medium speed (V3),
 - circular return and discharge,
 - ducted return and discharge (1.5 m),
 - G3 standard filter.
- (3) Informative data, considering an hypothetical sound attenuation of the room and installation of 21dB.

Sound Power Levels Lw in dB(A) - VH 07

Speeds	Type	Acoustical power per octave band (dB(A))						Lw global dB(A)	Lp global dB(A) (3)	NR (3)
		125Hz	250Hz	500Hz	1kHz	2kHz	4kHz			
V1	Return + Radiated (1)	42.9	47.7	47.0	48.1	46.4	36.9	53.8	32.8	27
	Discharge (1)	41.8	45.9	49.1	44.5	41.9	29.8	52.6		
	Radiated (2)	33.9	37.9	38.6	40.0	36.2	25.8	44.8		
V2	Return + Radiated (1)	46.9	51.8	50.2	51.9	51.0	42.6	57.8	36.8	32
	Discharge (1)	45.8	50.4	48.6	48.9	46.3	35.5	55.4		
	Radiated (2)	37.3	41.0	40.9	43.0	39.9	30.4	47.9		
V3	Return + Radiated (1)	49.5	54.3	52.2	54.2	53.6	46.5	60.3	39.3	34
	Discharge (1)	49.0	53.6	51.3	52.0	50.1	40.9	58.6		
	Radiated (2)	39.7	43.1	42.6	45.0	42.0	33.4	49.9		
V4	Return + Radiated (1)	51.1	56.2	53.3	55.5	55.4	48.7	61.9	40.9	36
	Discharge (1)	50.6	55.5	53.0	54.1	51.9	42.8	60.4		
	Radiated (2)	40.8	44.5	43.6	45.7	43.0	34.8	50.9		
V5	Return + Radiated (1)	52.0	57.3	54.3	56.6	56.5	50.2	63.0	42.0	37
	Discharge (1)	51.8	56.7	54.5	55.0	52.6	43.9	61.5		
	Radiated (2)	41.6	45.4	44.6	46.9	44.4	36.5	52.0		

- (1) According Eurovent 8/2, data given for a unit with :
 - 50 Pa external static pressure in medium speed (V3),
 - circular return and discharge,
 - G3 standard filter.
- (2) Data given for a unit with :
 - 50 Pa external static pressure in medium speed (V3),
 - circular return and discharge,
 - ducted return and discharge (1.5 m),
 - G3 standard filter.
- (3) Informative data, considering an hypothetical sound attenuation of the room and installation of 21dB.

Sound Power Levels Lw in dB(A) - VH 10

Speeds	Type	Acoustical power per octave band (dB(A))						Lw global dB(A)	Lp global dB(A) (3)	NR (3)
		125Hz	250Hz	500Hz	1kHz	2kHz	4kHz			
V1	Return + Radiated (1)	40.2	43.5	47.2	44.7	41.6	31.2	51.2	30.2	25
	Discharge (1)	39.8	42.9	43.3	42.8	40.6	26.2	49.1		
	Radiated (2)	31.5	34.4	41.6	36.5	31.0	16.9	43.9		
V2	Return + Radiated (1)	45.5	48.7	49.8	49.9	48.0	38.9	55.7	34.7	29
	Discharge (1)	44.7	47.6	46.5	47.6	46.3	34.6	53.7		
	Radiated (2)	36.5	39.1	42.6	41.5	37.4	26.1	47.0		
V3	Return + Radiated (1)	49.7	53.6	52.5	53.2	52.2	44.0	59.5	38.5	33
	Discharge (1)	48.7	51.9	50.1	51.7	50.3	39.8	57.8		
	Radiated (2)	40.7	43.1	44.8	44.7	41.6	32.7	50.3		
V4	Return + Radiated (1)	52.6	56.4	55.3	56.2	55.7	48.6	62.6	41.6	36
	Discharge (1)	52.2	55.0	53.1	54.4	53.2	44.7	60.8		
	Radiated (2)	42.8	45.8	46.8	47.2	44.5	37.0	52.8		
V5	Return + Radiated (1)	53.2	57.6	56.3	57.1	56.8	50.3	63.7	42.7	38
	Discharge (1)	53.7	56.7	54.6	55.7	54.7	46.7	62.3		
	Radiated (2)	44.0	47.4	48.0	48.4	45.7	38.7	54.1		

- (1) According Eurovent 8/2, data given for a unit with :
 - 50 Pa external static pressure in medium speed (V3),
 - circular return and discharge,
 - G3 standard filter.
- (2) Data given for a unit with :
 - 50 Pa external static pressure in medium speed (V3),
 - circular return and discharge,
 - ducted return and discharge (1.5 m),
 - G3 standard filter.
- (3) Informative data, considering an hypothetical sound attenuation of the room and installation of 21dB.

Sound Power Levels Lw in dB(A) - VH 15/18/21

Speeds	Type	Acoustical power per octave band (dB(A))						Lw global dB(A)	Lp global dB(A) (3)	NR (3)
		125Hz	250Hz	500Hz	1kHz	2kHz	4kHz			
V1	Return + Radiated (1)	49.6	41.9	44.5	44.5	37.1	21.9	52.2	31.2	27
	Discharge (1)	49.5	41.3	43.1	44.3	37.5	22.8	52.0		
	Radiated (2)	45.1	32.8	33.9	33.0	24.4	11.9	45.9		
V2	Return + Radiated (1)	51.0	48.3	50.4	52.7	49.1	37.8	57.6	36.6	32
	Discharge (1)	49.5	47.8	48.8	52.1	48.0	36.5	56.6		
	Radiated (2)	46.3	40.5	40.5	41.3	33.3	22.4	49.1		
V3	Return + Radiated (1)	54.5	57.7	57.5	60.6	59.3	50.8	65.5	44.5	40
	Discharge (1)	52.2	56.6	56.1	60.0	57.8	49.5	64.4		
	Radiated (2)	47.0	47.2	45.8	47.8	42.5	30.6	53.4		
V4	Return + Radiated (1)	57.1	61.4	60.7	63.7	63.4	56.1	69.1	48.1	44
	Discharge (1)	55.4	60.8	58.8	63.1	61.5	54.0	67.8		
	Radiated (2)	49.5	50.8	48.9	51.0	45.8	36.4	56.6		
V5	Return + Radiated (1)	59.7	64.4	63.4	66.1	66.4	59.6	71.8	50.8	47
	Discharge (1)	57.9	64.5	61.8	65.7	64.7	57.9	70.9		
	Radiated (2)	51.6	54.1	51.7	53.5	49.2	40.2	59.4		

- (1) According Eurovent 8/2, data given for a unit with :
 - 50 Pa external static pressure in medium speed (V3),
 - rectangular return and discharge,
 - G3 standard filter.
- (2) Data given for a unit with :
 - 50 Pa external static pressure in medium speed (V3),
 - rectangular return and discharge,
 - ducted return and discharge (1.5 m),
 - G3 standard filter.
- (3) Informative data, considering an hypothetical sound attenuation of the room and installation of 21dB.

Sound Power Levels Lw in dB(A) - VH 24/27

Speeds	Type	Acoustical power per octave band (dB(A))						Lw global dB(A)	Lp global dB(A) (3)	NR (3)
		125Hz	250Hz	500Hz	1kHz	2kHz	4kHz			
V1	Return + Radiated (1)	52.4	56.4	57.7	59.8	59.1	52.2	65.0	44.0	40
	Discharge (1)	50.6	54.6	56.0	58.5	57.8	51.2	63.5		
	Radiated (2)	42.6	45.0	45.7	47.0	41.9	32.7	51.9		
V2	Return + Radiated (1)	56.5	60.6	61.7	63.6	63.4	57.2	69.1	48.1	44
	Discharge (1)	54.1	58.0	59.2	61.5	61.3	55.8	66.9		
	Radiated (2)	45.9	48.0	49.7	50.3	45.8	37.8	55.4		
V3	Return + Radiated (1)	59.6	64.1	64.8	66.7	67.1	61.6	72.5	51.5	48
	Discharge (1)	58.6	63.1	63.9	65.5	65.8	61.3	71.5		
	Radiated (2)	49.7	52.7	53.3	53.9	50.3	43.4	59.4		
V4	Return + Radiated (1)	62.4	67.3	67.3	69.3	69.9	64.8	75.4	54.4	51
	Discharge (1)	61.6	66.9	66.5	68.7	69.1	65.1	74.8		
	Radiated (2)	52.7	56.5	55.7	57.0	53.6	47.2	62.5		

- (1) According Eurovent 8/2, data given for a unit with :
 - 50 Pa external static pressure in medium speed (V2),
 - rectangular return and discharge,
 - G3 standard filter.
- (2) Data given for a unit with :
 - 50 Pa external static pressure in medium speed (V2),
 - rectangular return and discharge,
 - ducted return and discharge (1.5 m),
 - G3 standard filter.
- (3) Informative data, considering an hypothetical sound attenuation of the room and installation of 21dB.

Air Flow Data

VH 03 - Rectangular return / Rectangular discharge - Air flow (m³/h)

Speeds	Filter	External static pressure (Pa)						
		0	25	50	80	100	120	150
V1	Without	205	106	-	-	-	-	-
	G3	200	102	-	-	-	-	-
	G4	192	101	-	-	-	-	-
V2	Without	275	210	144	-	-	-	-
	G3	270	207	144	-	-	-	-
	G4	258	200	139	-	-	-	-
V3	Without	357	314	271	221	-	-	-
	G3	345	305	265	218	-	-	-
	G4	333	296	259	214	-	-	-
V4	Without	460	432	406	374	353	331	-
	G3	446	420	396	366	346	324	-
	G4	430	407	385	357	337	317	-
V5	Without	541	513	485	454	433	411	-
	G3	521	495	470	441	421	400	-
	G4	497	475	453	426	407	387	-
V6	Without	660	637	612	578	553	524	-
	G3	635	611	586	552	526	497	-
	G4	602	578	554	520	494	462	-

VH 03 - Rectangular return / Circular discharge - Air flow (m³/h)

Speeds	Filter	External static pressure (Pa)						
		0	25	50	80	100	120	150
V1	Without	205	104	-	-	-	-	-
	G3	200	101	-	-	-	-	-
	G4	192	98	-	-	-	-	-
V2	Without	275	209	144	-	-	-	-
	G3	270	206	144	-	-	-	-
	G4	258	200	138	-	-	-	-
V3	Without	357	313	270	221	-	-	-
	G3	345	305	265	218	-	-	-
	G4	333	296	259	214	-	-	-
V4	Without	460	431	404	374	353	329	-
	G3	446	419	395	366	345	321	-
	G4	430	406	384	357	335	311	-
V5	Without	538	510	483	452	431	410	-
	G3	520	493	469	440	420	399	-
	G4	496	473	451	425	406	385	-
V6	Without	657	634	609	575	549	520	-
	G3	632	608	583	549	523	494	-
	G4	598	575	551	517	491	461	-

VH 03 - Circular return / Circular discharge - Air flow (m³/h)

Speeds	Filter	External static pressure (Pa)						
		0	25	50	80	100	120	150
V1	Without	195	97	-	-	-	-	-
	G3	190	95	-	-	-	-	-
	G4	182	95	-	-	-	-	-
V2	Without	258	205	148	-	-	-	-
	G3	252	202	148	-	-	-	-
	G4	245	197	144	-	-	-	-
V3	Without	335	304	275	240	-	-	-
	G3	327	299	271	237	-	-	-
	G4	320	292	266	234	-	-	-
V4	Without	457	429	400	365	344	325	-
	G3	442	416	390	358	336	315	-
	G4	428	402	377	348	329	311	-
V5	Without	535	508	479	441	416	390	-
	G3	515	490	462	426	403	380	-
	G4	493	469	443	411	389	369	-
V6	Without	650	627	599	559	528	495	-
	G3	625	600	570	530	501	469	-
	G4	590	563	535	497	468	435	-

Air Flow Data (continued)

VH 05 - Rectangular return / Rectangular discharge - Air flow (m³/h)

Speeds	Filter	External static pressure (Pa)						
		0	25	50	60	70	80	90
V1	Without	450	324	-	-	-	-	-
	G3	410	300	-	-	-	-	-
	G4	405	297	-	-	-	-	-
V2	Without	560	432	308	-	-	-	-
	G3	510	396	287	-	-	-	-
	G4	500	391	283	-	-	-	-
V3	Without	645	534	405	342	-	-	-
	G3	590	487	366	309	-	-	-
	G4	578	480	360	304	-	-	-
V4	Without	800	668	515	443	360	-	-
	G3	710	591	449	384	313	-	-
	G4	695	579	443	379	309	-	-
V5	Without	1020	866	687	606	518	422	-
	G3	880	744	583	512	437	357	-
	G4	850	717	566	499	428	351	-
V6	Without	1310	1134	964	881	782	663	518
	G3	1110	959	788	707	614	508	386
	G4	1050	908	750	675	589	490	376

VH 05 - Rectangular return / Circular discharge - Air flow (m³/h)

Speeds	Filter	External static pressure (Pa)						
		0	25	50	60	70	80	90
V1	Without	425	307	-	-	-	-	-
	G3	390	287	-	-	-	-	-
	G4	385	284	-	-	-	-	-
V2	Without	525	409	292	-	-	-	-
	G3	485	378	273	-	-	-	-
	G4	475	373	269	-	-	-	-
V3	Without	610	505	379	318	-	-	-
	G3	560	463	344	290	-	-	-
	G4	550	456	340	285	-	-	-
V4	Without	740	618	475	406	327	-	-
	G3	670	555	422	360	291	-	-
	G4	650	544	414	352	285	-	-
V5	Without	910	776	617	544	465	379	-
	G3	810	681	535	471	402	328	-
	G4	780	661	522	460	394	324	-
V6	Without	1130	988	834	757	666	559	432
	G3	990	852	701	627	543	445	331
	G4	945	819	675	605	526	434	328

VH 05 - Circular return / Circular discharge - Air flow (m³/h)

Speeds	Filter	External static pressure (Pa)						
		0	25	50	60	70	80	90
V1	Without	405	310	-	-	-	-	-
	G3	380	294	-	-	-	-	-
	G4	375	291	-	-	-	-	-
V2	Without	505	403	300	-	-	-	-
	G3	470	375	282	-	-	-	-
	G4	460	371	280	-	-	-	-
V3	Without	585	486	370	315	-	-	-
	G3	542	448	340	289	-	-	-
	G4	535	442	336	285	-	-	-
V4	Without	685	580	454	396	332	-	-
	G3	630	528	410	358	301	-	-
	G4	620	519	405	354	297	-	-
V5	Without	810	693	569	508	437	354	-
	G3	730	627	506	447	381	306	-
	G4	710	613	495	438	374	301	-
V6	Without	970	845	713	647	571	479	371
	G3	865	753	620	556	483	399	303
	G4	840	730	602	540	470	391	300

Air Flow Data (continued)

VH 07 - Rectangular return / Rectangular discharge - Air flow (m³/h)

Speeds	Filter	External static pressure (Pa)							
		0	25	50	75	95	100	105	110
V1	Without	845	775	707	639	-	-	-	-
	G3	810	745	679	613	-	-	-	-
	G4	798	733	671	607	-	-	-	-
V2	Without	1030	970	908	831	750	-	-	-
	G3	995	937	871	787	700	-	-	-
	G4	975	919	853	768	682	-	-	-
V3	Without	1300	1219	1150	1056	937	898	-	-
	G3	1250	1170	1093	979	836	791	-	-
	G4	1210	1137	1056	933	784	737	-	-
V4	Without	1730	1605	1490	1345	1180	1129	1074	-
	G3	1615	1498	1372	1205	1020	965	905	-
	G4	1525	1408	1282	1116	935	881	824	-
V5	Without	2000	1848	1716	1559	1382	1328	1269	1205
	G3	1845	1703	1558	1376	1180	1122	1059	991
	G4	1711	1574	1432	1254	1065	1009	950	886

VH 07 - Rectangular return / Circular discharge - Air flow (m³/h)

Speeds	Filter	External static pressure (Pa)							
		0	25	50	75	95	100	105	110
V1	Without	815	747	683	617	-	-	-	-
	G3	785	720	658	592	-	-	-	-
	G4	771	709	650	585	-	-	-	-
V2	Without	995	938	873	790	705	-	-	-
	G3	965	906	836	747	654	-	-	-
	G4	945	887	818	728	638	-	-	-
V3	Without	1245	1166	1091	981	842	798	-	-
	G3	1195	1118	1031	899	737	687	-	-
	G4	1160	1085	992	853	688	637	-	-
V4	Without	1590	1470	1354	1200	1023	968	909	-
	G3	1490	1377	1247	1070	877	819	757	-
	G4	1410	1301	1167	991	810	758	703	-
V5	Without	1800	1658	1524	1358	1174	1119	1059	994
	G3	1665	1533	1388	1202	1003	945	882	816
	G4	1556	1430	1285	1102	914	860	802	741

VH 07 - Circular return / Circular discharge - Air flow (m³/h)

Speeds	Filter	External static pressure (Pa)							
		0	25	50	75	95	100	105	110
V1	Without	790	729	670	610	-	-	-	-
	G3	765	704	648	587	-	-	-	-
	G4	752	696	641	582	-	-	-	-
V2	Without	990	929	859	748	611	-	-	-
	G3	960	893	814	683	516	-	-	-
	G4	940	874	792	659	491	-	-	-
V3	Without	1280	1161	1050	912	758	711	-	-
	G3	1220	1098	977	826	663	614	-	-
	G4	1145	1053	936	787	637	594	-	-
V4	Without	1545	1403	1250	1072	899	851	800	-
	G3	1430	1288	1137	959	786	736	685	-
	G4	1340	1210	1069	900	735	688	639	-
V5	Without	1760	1588	1401	1194	1007	956	905	852
	G3	1595	1428	1251	1055	878	830	781	731
	G4	1470	1320	1159	980	821	779	736	691

Air Flow Data (continued)

VH 10 - Rectangular return / Rectangular discharge - Air flow (m³/h)

Speeds	Filter	External static pressure (Pa)							
		0	25	50	60	80	90	100	105
V1	Without	810	727	646	615	-	-	-	-
	G3	785	707	630	600	-	-	-	-
	G4	750	673	602	574	-	-	-	-
V2	Without	1035	956	871	829	723	-	-	-
	G3	1005	929	840	796	685	-	-	-
	G4	955	879	782	734	616	-	-	-
V3	Without	1280	1193	1111	1070	956	878	-	-
	G3	1240	1152	1065	1017	883	788	-	-
	G4	1176	1088	985	925	754	634	-	-
V4	Without	1765	1602	1456	1391	1229	1125	1003	-
	G3	1640	1496	1349	1280	1110	1005	882	-
	G4	1481	1348	1196	1122	940	827	697	-
V5	Without	2130	1928	1750	1673	1488	1372	1237	1161
	G3	1940	1769	1590	1508	1314	1197	1065	992
	G4	1700	1546	1364	1279	1084	972	849	782

VH 10 - Rectangular return / Circular discharge - Air flow (m³/h)

Speeds	Filter	External static pressure (Pa)							
		0	25	50	60	80	90	100	105
V1	Without	805	725	645	614	-	-	-	-
	G3	780	705	627	599	-	-	-	-
	G4	746	672	601	575	-	-	-	-
V2	Without	1030	953	868	826	720	-	-	-
	G3	1000	925	836	792	682	-	-	-
	G4	955	876	778	730	615	-	-	-
V3	Without	1270	1187	1107	1065	948	868	-	-
	G3	1235	1143	1062	1017	879	776	-	-
	G4	1171	1084	979	919	747	628	-	-
V4	Without	1745	1588	1439	1373	1213	1114	1000	-
	G3	1625	1483	1336	1267	1099	994	872	-
	G4	1471	1336	1184	1111	931	820	693	-
V5	Without	2100	1902	1724	1646	1461	1347	1213	1138
	G3	1910	1745	1567	1485	1293	1177	1047	976
	G4	1680	1528	1347	1263	1071	960	839	774

VH 10 - Circular return / Circular discharge - Air flow (m³/h)

Speeds	Filter	External static pressure (Pa)							
		0	25	50	60	80	90	100	105
V1	Without	770	713	655	631	-	-	-	-
	G3	755	699	643	619	-	-	-	-
	G4	730	675	620	595	-	-	-	-
V2	Without	985	927	856	820	732	-	-	-
	G3	965	904	829	791	699	-	-	-
	G4	930	864	781	740	636	-	-	-
V3	Without	1265	1180	1079	1029	909	835	-	-
	G3	1225	1134	1027	976	851	776	-	-
	G4	1150	1059	944	889	759	684	-	-
V4	Without	1730	1576	1406	1328	1151	1048	933	-
	G3	1620	1460	1292	1217	1045	946	835	-
	G4	1450	1298	1137	1064	893	791	675	-
V5	Without	2050	1852	1648	1558	1353	1234	1103	1032
	G3	1860	1684	1486	1398	1199	1087	965	900
	G4	1630	1459	1270	1187	1003	901	791	733

Air Flow Data (continued)

VH 15, 18 & 21 - Rectangular return / Rectangular discharge - Air flow (m³/h)

Speeds	Filter	Pression disponible (Pa)									
		0	25	50	75	100	125	150	180	190	200
V1	Without	1150	949	739	540	-	-	-	-	-	-
	G3	1070	882	671	480	-	-	-	-	-	-
	G4	1040	859	665	473	-	-	-	-	-	-
V2	Without	1685	1530	1370	1207	1040	870	700	-	-	-
	G3	1559	1431	1285	1138	994	847	681	-	-	-
	G4	1521	1381	1242	1104	965	824	679	-	-	-
V3	Without	2500	2378	2243	2093	1912	1707	1490	1100	-	-
	G3	2370	2249	2112	1958	1789	1598	1371	1000	-	-
	G4	2280	2151	1996	1848	1683	1487	1257	876	-	-
V4	Without	3130	2965	2786	2603	2404	2175	1915	1560	1410	-
	G3	2905	2770	2617	2443	2250	2039	1801	1450	1307	-
	G4	2751	2587	2426	2248	2049	1831	1593	1260	1130	-
V5	Without	3830	3630	3403	3177	2933	2662	2373	1996	1854	1699
	G3	3545	3369	3176	2967	2739	2490	2220	1850	1710	1560
	G4	3240	3048	2847	2634	2408	2170	1918	1588	1468	1341

VH 24 & 27 - Rectangular return / Rectangular discharge - Air flow (m³/h)

Speeds	Filter	Pression disponible (Pa)									
		0	25	50	75	100	150	175	200	210	220
V1	Without	2390	2229	2062	1878	1681	1260	1010	-	-	-
	G3	2230	2093	1938	1765	1580	1178	940	-	-	-
	G4	2149	2025	1862	1687	1510	1137	900	-	-	-
V2	Without	2860	2720	2553	2373	2179	1732	1472	1184	-	-
	G3	2720	2572	2413	2235	2046	1640	1400	1138	-	-
	G4	2580	2416	2264	2107	1935	1524	1285	1032	-	-
V3	Without	3650	3489	3320	3133	2928	2472	2199	1861	1700	-
	G3	3450	3290	3103	2914	2700	2223	1950	1610	1470	-
	G4	3202	3055	2890	2708	2514	2088	1835	1515	1357	-
V4	Without	4650	4454	4229	4001	3750	3179	2863	2494	2326	2149
	G3	4270	4099	3882	3667	3432	2890	2578	2206	2044	1892
	G4	3861	3679	3487	3277	3049	2551	2276	1959	1813	1650

Performance Data in Cooling Mode - 2-pipe system

VH sizes	Speeds		V1	V2	V3	V4	V5	V6
03	Air flow	m ³ /h	-	148	271	390	462	570
	Total capacity	W	-	1162	1646	1886	1980	2083
	Sensible capacity	W	-	792	1218	1524	1686	1909
05	Air flow	m ³ /h	-	282	340	410	506	620
	Total capacity	W	-	2049	2283	2503	2720	2898
	Sensible capacity	W	-	1460	1660	1867	2106	2351
07	Air flow	m ³ /h	648	814	977	1137	1251	-
	Total capacity	W	4377	5001	5503	5914	6165	-
	Sensible capacity	W	3110	3661	4148	4583	4873	-
10	Air flow	m ³ /h	643	829	1027	1292	1486	-
	Total capacity	W	4577	5560	6539	7615	8458	-
	Sensible capacity	W	3267	4028	4815	5727	6408	-
15	Air flow	m ³ /h	671	1285	2112	2617	3176	-
	Total capacity	W	5351	8716	11927	13416	14819	-
	Sensible capacity	W	3855	6586	9614	11232	12896	-
18	Air flow	m ³ /h	671	1285	2112	2617	3176	-
	Total capacity	W	5753	9949	14428	16685	18888	-
	Sensible capacity	W	4041	7186	10844	12847	14923	-
21	Air flow	m ³ /h	671	1285	2112	2617	3176	-
	Total capacity	W	5960	10699	16129	19030	21947	-
	Sensible capacity	W	4120	7546	11691	13995	16413	-
24	Air flow	m ³ /h	1938	2413	3103	3882	-	-
	Total capacity	W	14623	17243	20581	23866	-	-
	Sensible capacity	W	10670	12793	15642	18623	-	-
27	Air flow	m ³ /h	1938	2413	3103	3882	-	-
	Total capacity	W	16107	19399	23798	28364	-	-
	Sensible capacity	W	11331	13780	17147	20761	-	-

Performance data based on :

- Air : 27 °C/19 °C (wet bulb), Chilled water : 7/12 °C. Units with G3 filter and 50 Pa external static pressure.
- Circular return/Circular discharge for sizes 03 to 10 and Rectangular return/Rectangular discharge for sizes 15 to 27.

Performance Data in Heating Mode - 2-pipe system

VH sizes	Speeds		V1	V2	V3	V4	V5	V6
03	Air flow	m ³ /h	-	148	271	390	462	570
	Heating capacity	W	-	1290	2082	2722	3127	3480
05	Air flow	m ³ /h	-	282	340	410	506	620
	Heating capacity	W	-	2485	2911	3372	3964	4564
07	Air flow	m ³ /h	648	814	977	1137	1251	-
	Heating capacity	W	5160	6149	7058	7861	8360	-
10	Air flow	m ³ /h	643	829	1027	1292	1486	-
	Heating capacity	W	5627	7001	8396	10251	11658	-
15	Air flow	m ³ /h	671	1285	2112	2617	3176	-
	Heating capacity	W	5886	10114	14870	17384	19913	-
18	Air flow	m ³ /h	671	1285	2112	2617	3176	-
	Heating capacity	W	6308	11293	17054	20262	23535	-
21	Air flow	m ³ /h	671	1285	2112	2617	3176	-
	Heating capacity	W	6452	11755	18111	21652	25319	-
24	Air flow	m ³ /h	1938	2413	3103	3882	-	-
	Heating capacity	W	17813	21616	26823	32282	-	-
27	Air flow	m ³ /h	1938	2413	3103	3882	-	-
	Heating capacity	W	18276	22286	27883	33870	-	-

Performance data based on :

- Air : 20 °C, entering water temperature : 50 °C, water flow is the same as that in cooling mode.
- Units with G3 filter and 50 Pa external static pressure.
- Circular return/Circular discharge for sizes 03 to 10 and Rectangular return/Rectangular discharge for sizes 15 to 27.

Performance Data in Cooling Mode - 4-pipe system

VH sizes	Speeds		V1	V2	V3	V4	V5	V6
03	Air flow	m ³ /h	-	148	271	390	462	570
	Total capacity	W	-	1030	1371	1527	1585	1649
	Sensible capacity	W	-	719	1058	1298	1423	1595
05	Air flow	m ³ /h	-	282	340	410	506	620
	Total capacity	W	-	2065	2303	2530	2759	2954
	Sensible capacity	W	-	1508	1724	1957	2239	2539
07	Air flow	m ³ /h	648	814	977	1137	1251	-
	Total capacity	W	4014	4570	5017	5381	5607	-
	Sensible capacity	W	2855	3331	3746	4115	4358	-
10	Air flow	m ³ /h	643	829	1027	1292	1486	-
	Total capacity	W	3581	4267	5045	5769	6409	-
	Sensible capacity	W	2707	3312	4016	4718	5294	-
15	Air flow	m ³ /h	671	1285	2112	2617	3176	-
	Total capacity	W	5065	7924	10463	11582	12575	-
	Sensible capacity	W	3702	6170	8837	10240	11666	-
18	Air flow	m ³ /h	671	1285	2112	2617	3176	-
	Total capacity	W	5276	8514	11567	12969	14251	-
	Sensible capacity	W	3843	6543	9546	11156	12814	-
21	Air flow	m ³ /h	671	1285	2112	2617	3176	-
	Total capacity	W	5790	10090	14761	17145	19532	-
	Sensible capacity	W	4059	7248	10973	13014	15153	-
24	Air flow	m ³ /h	1938	2413	3103	3882	-	-
	Total capacity	W	13584	15789	18501	21067	-	-
	Sensible capacity	W	10230	12160	14715	17346	-	-
27	Air flow	m ³ /h	1938	2413	3103	3882	-	-
	Total capacity	W	14678	17303	20662	23945	-	-
	Sensible capacity	W	10675	12799	15679	18686	-	-

Performance data based on :

- Air : 27 °C/19 °C (wet bulb), Chilled water : 7/12 °C. Units with G3 filter and 50 Pa external static pressure.
- Circular return/Circular discharge for sizes 03 to 10 and Rectangular return/Rectangular discharge for sizes 15 to 27.

Performance Data in Heating Mode - 4-pipe system

VH sizes	Speeds		V1	V2	V3	V4	V5	V6
03	Air flow	m ³ /h	-	148	271	390	462	570
	Heating capacity	W	-	1464	2280	2936	3288	3770
05	Air flow	m ³ /h	-	282	340	410	506	620
	Heating capacity	W	-	3249	3770	4373	5137	5984
07	Air flow	m ³ /h	648	814	977	1137	1251	-
	Heating capacity	W	5620	6597	7479	8278	8815	-
10	Air flow	m ³ /h	643	829	1027	1292	1486	-
	Heating capacity	W	7791	9103	10167	12062	13418	-
15	Air flow	m ³ /h	671	1285	2112	2617	3176	-
	Heating capacity	W	8150	13468	19220	22218	25215	-
18	Air flow	m ³ /h	671	1285	2112	2617	3176	-
	Heating capacity	W	8258	13519	19219	22209	25213	-
21	Air flow	m ³ /h	671	1285	2112	2617	3176	-
	Heating capacity	W	8258	13519	19219	22209	25213	-
24	Air flow	m ³ /h	1938	2413	3103	3882	-	-
	Heating capacity	W	20157	23636	28176	32766	-	-
27	Air flow	m ³ /h	1938	2413	3103	3882	-	-
	Heating capacity	W	20176	23639	28177	32786	-	-

Performance data based on :

- Air : 20 °C, hot water : 70/60 °C.
- Units with G3 filter and 50 Pa external static pressure.
- Circular return/Circular discharge for sizes 03 to 10 and Rectangular return/Rectangular discharge for sizes 15 to 27.

2-pipe system

Sizes	Fan speed	Air flow (m³/h)	External static pressure (Pa)	Cooling			Heating		Sound levels Lw	
				Total capacity (W)	Sensible capacity (W)	WPD (kPa)	Heating cap. (W)	WPD (kPa)	Return + radiated (dBA)	Discharge (dBA)
VH 03	LS	141	15	1087	736	3.1	1190	2.5	41.3	39.5
	MS	271	50	1646	1218	6.6	2082	5.2	56.2	54.9
	HS	395	110	1888	1527	8.4	2729	6.7	65.1	64.4
VH 05	LS	270	35	1953	1386	5.2	2354	4.1	48.2	47.4
	MS	340	50	2283	1660	6.5	2911	5.0	53.2	52.0
	HS	398	70	2419	1785	7.2	3184	5.7	56.4	55.5
VH 07	LS	703	30	4560	3266	27.4	5373	21.5	53.8	52.6
	MS	977	50	5503	4148	39.2	7058	31.1	60.3	58.6
	HS	1125	70	5814	4474	43.5	7628	34.5	63.0	61.5
VH 10	LS	705	25	4823	3469	13.1	6020	11.6	51.2	49.1
	MS	1027	50	6531	4809	22.9	8443	20.6	59.5	57.8
	HS	1255	75	7801	5722	31.8	10179	28.8	63.7	62.3
VH 15	LS	960	15	7084	5218	7.9	8007	6.3	52.2	52.0
	MS	2112	50	11926	9614	19.8	14870	16.0	65.5	64.4
	HS	2830	90	13987	11892	26.1	18365	21.1	71.8	70.9
VH 18	LS	960	15	7856	5585	6.8	8730	5.4	52.2	52.0
	MS	2112	50	14428	10844	19.6	17054	15.7	65.5	64.4
	HS	2830	90	17559	13658	27.6	21619	22.3	71.8	70.9
VH 21	LS	960	15	8294	5777	8.5	9014	7.0	52.2	52.0
	MS	2112	50	16129	11691	28.7	18111	23.7	65.5	64.4
	HS	2830	90	20184	14942	43.5	23106	36.0	71.8	70.9
VH 24	LS	2040	35	15173	11105	13.3	18590	10.5	65.0	63.5
	MS	2413	50	17243	12793	16.6	21616	13.2	69.1	66.9
	HS	2925	75	19724	14886	21.1	25312	16.7	72.5	71.5
VH 27	LS	2040	35	16781	11830	13.6	19066	11.4	65.0	63.5
	MS	2413	50	19399	13780	17.6	22286	14.7	69.1	66.9
	HS	2925	75	22639	16244	23.0	26371	19.3	72.5	71.5

Performance data based on :

- **Cooling** : Air : 27 °C/19 °C (wet bulb) - Chilled water : 7/12 °C.
- **Heating** : Air : 20 °C, entering water temperature 50 °C, water flow identical to chilled water flow.
- Units with G3 filter. Circular return/Circular discharge for sizes 03 to 10 and Rectangular return/Rectangular discharge for sizes 15 to 27.
- According to Eurovent 6/9, Eurovent 6/10, Eurovent 8/12.

4-pipe system

Sizes	Fan speed	Air flow (m³/h)	External static pressure (Pa)	Cooling			Heating		Sound levels Lw	
				Total capacity (W)	Sensible capacity (W)	WPD (kPa)	Heating cap. (W)	WPD (kPa)	Return + radiated (dBA)	Discharge (dBA)
VH 03	LS	141	15	973	674	2.3	1357	1.9	41.3	39.5
	MS	271	50	1371	1058	4.3	2257	4.9	56.2	54.9
	HS	395	110	1528	1300	5.2	2911	7.9	65.1	64.4
VH 05	LS	270	35	1958	1409	4.6	3084	17.7	48.2	47.4
	MS	340	50	2303	1724	5.9	3768	23.6	53.2	52.0
	HS	398	70	2444	1865	6.5	4127	27.7	56.4	55.5
VH 07	LS	703	25	4178	2992	19.6	5892	9.5	53.8	52.6
	MS	977	50	5017	3746	26.9	7472	13.6	60.3	58.6
	HS	1125	70	5296	4024	29.7	8053	15.5	63.0	61.5
VH 10	LS	705	25	3719	2832	5.9	8304	25.9	51.2	49.1
	MS	1027	50	5045	4016	10.4	10132	36.9	59.5	57.8
	HS	1255	75	6063	4795	14.5	11897	48.6	63.7	62.3
VH 15	LS	960	15	6562	4944	5.8	10800	38.7	52.2	52.0
	MS	2112	50	10463	8837	13.3	19191	108.7	65.5	64.4
	HS	2830	90	11992	10808	16.9	23378	155.8	71.8	70.9
VH 18	LS	960	15	6953	5193	6.9	10887	23.8	52.2	52.0
	MS	2112	50	11567	9546	17.1	19189	66.3	65.5	64.4
	HS	2830	90	13495	11812	22.6	23367	95.0	71.8	70.9
VH 21	LS	960	15	7934	5625	11.1	10887	23.8	52.2	52.0
	MS	2112	50	14761	10973	34.9	19189	66.3	65.5	64.4
	HS	2830	90	18098	13856	50.9	23367	95.0	71.8	70.9
VH 24	LS	2040	35	14051	10629	15.3	20884	74.0	65.0	63.5
	MS	2413	50	15789	12160	18.8	23596	92.7	69.1	66.9
	HS	2925	75	17809	14040	23.3	26948	118.2	72.5	71.5
VH 27	LS	2040	35	15220	11109	13.5	20857	46.2	65.0	63.5
	MS	2413	50	17303	12799	17.0	23585	58.0	69.1	66.9
	HS	2925	75	19793	14913	21.5	26918	74.6	72.5	71.5

Performance data based on :

- **Cooling** : Air : 27 °C/19 °C (wet bulb) - Chilled water : 7/12 °C.
- **Heating** : Air : 20 °C - Hot water : 70/60 °C.
- Units with G3 filter. Circular return/Circular discharge for sizes 03 to 10 and Rectangular return/Rectangular discharge for sizes 15 to 27.
- According to Eurovent 6/9, Eurovent 6/10, Eurovent 8/12.

Water Pressure Drops - Cooling Mode - 2-pipe system

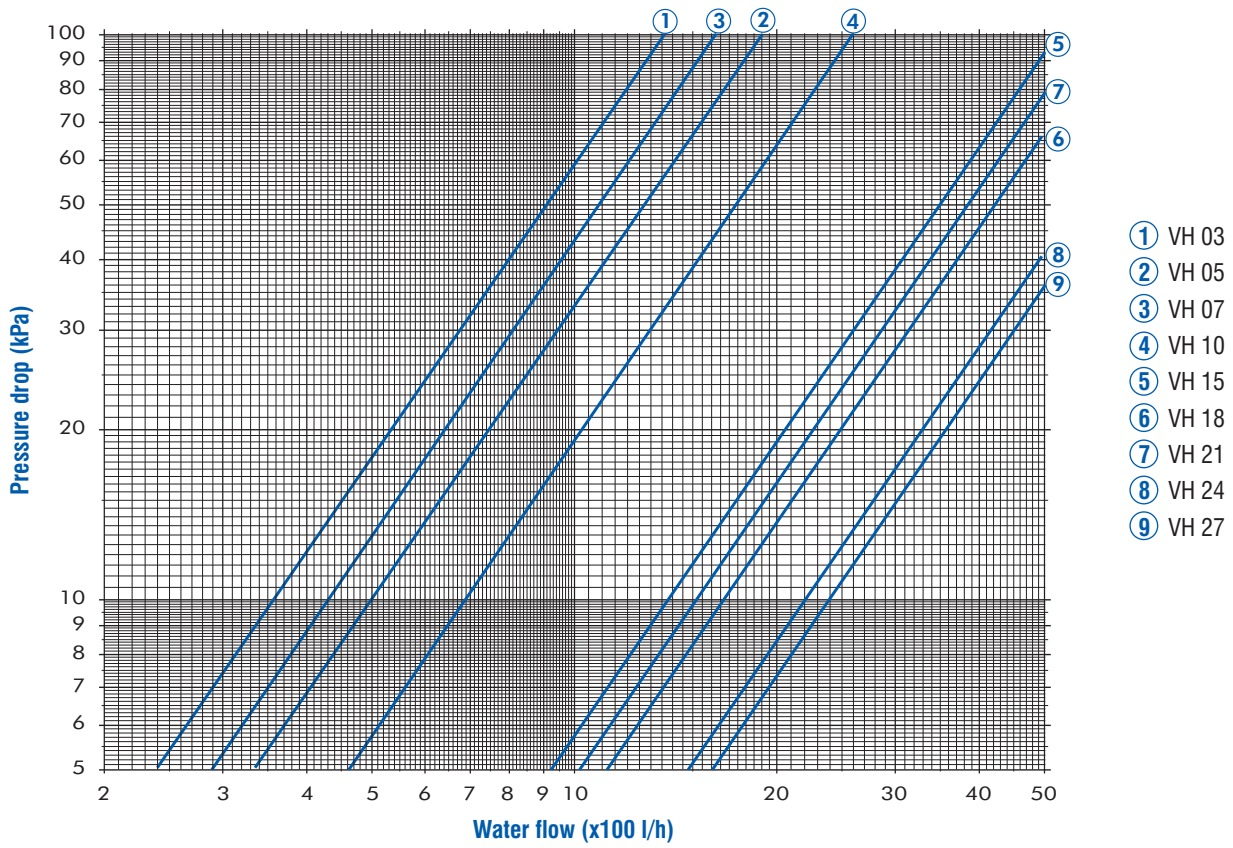

Water Pressure Drops - Heating Mode - 2-pipe system

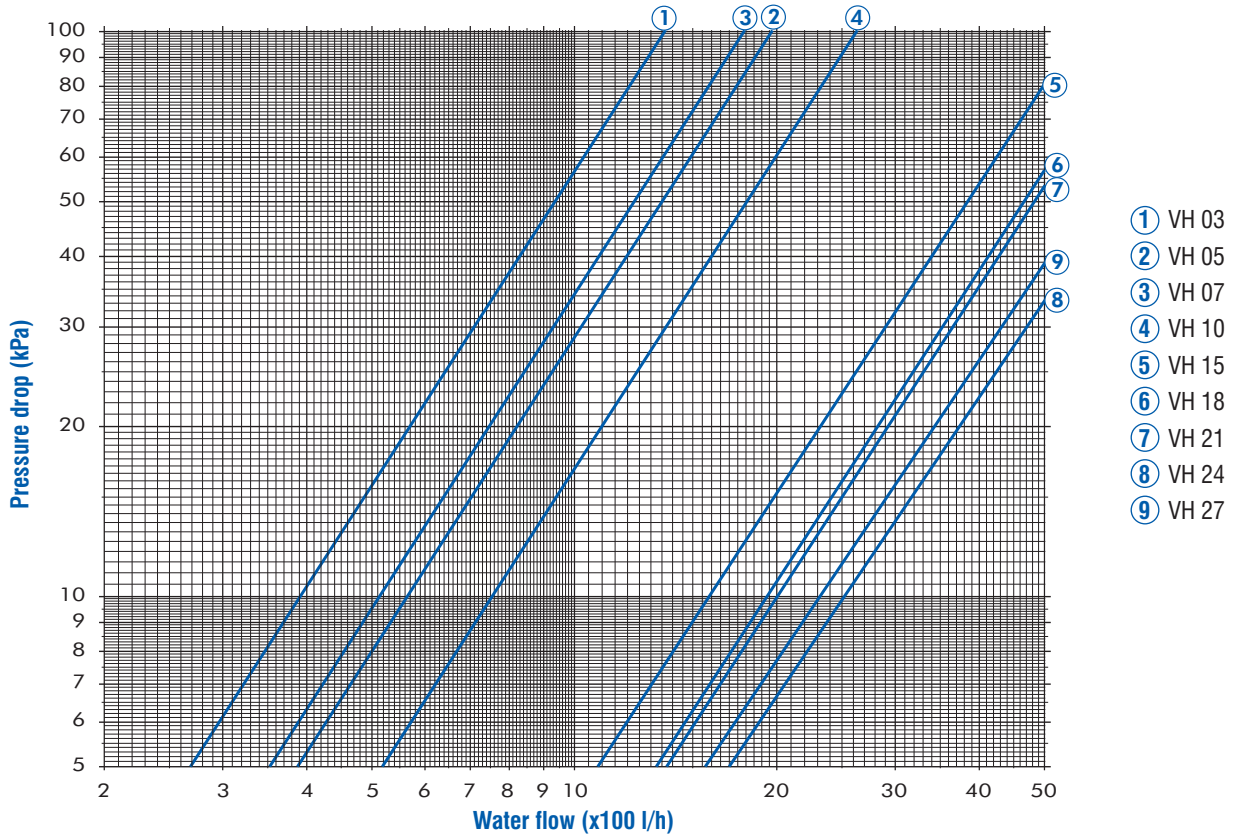

Water Pressure Drops - Cooling Mode - 4-pipe system

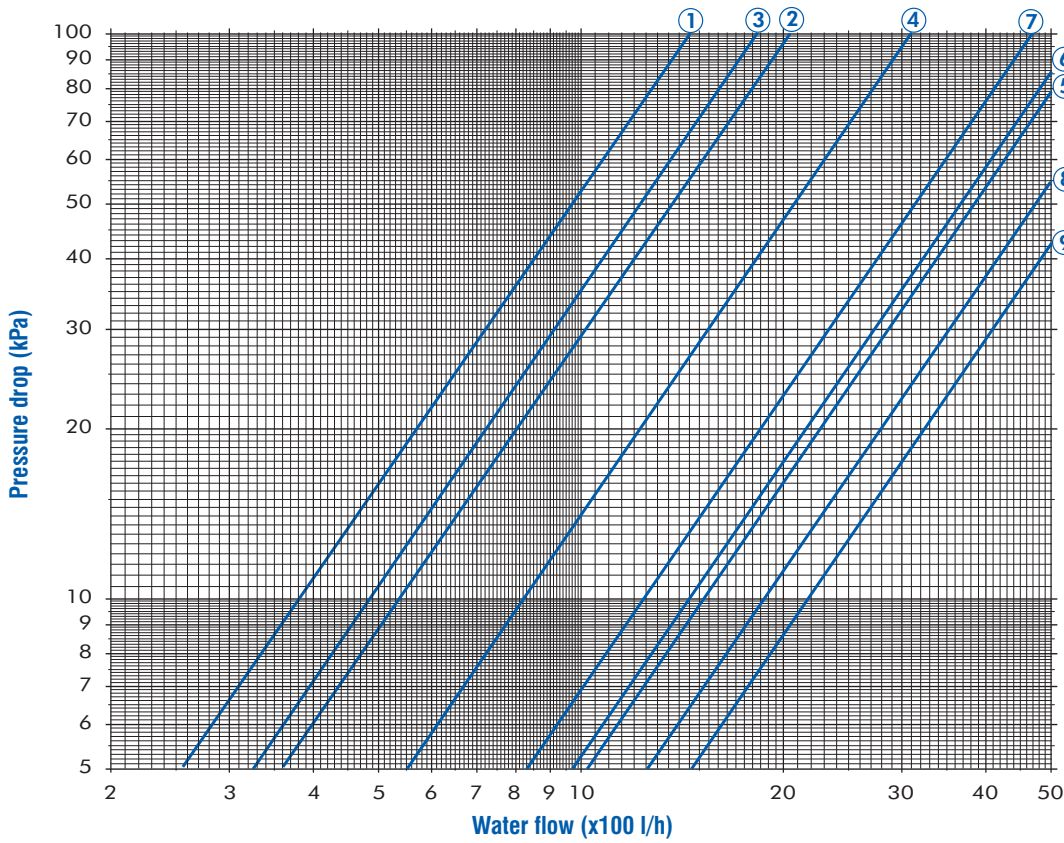

Water Pressure Drops - Heating Mode - 4-pipe system

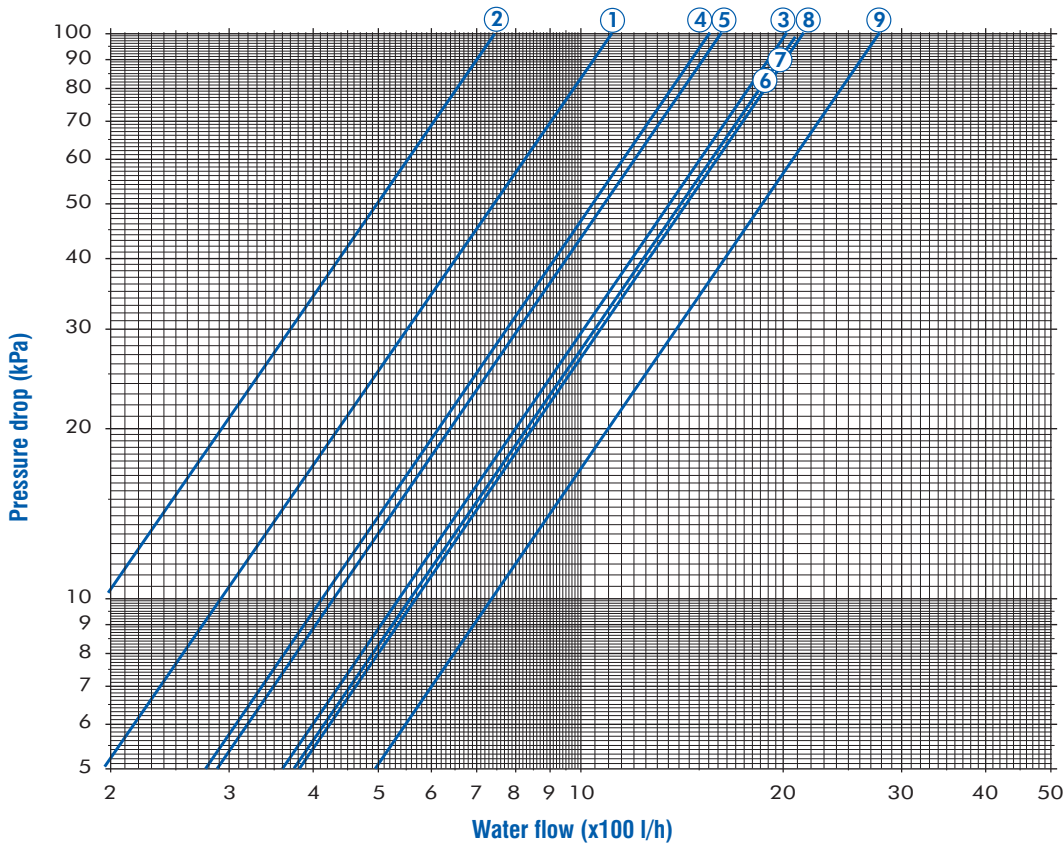

Dimensions - VH 03

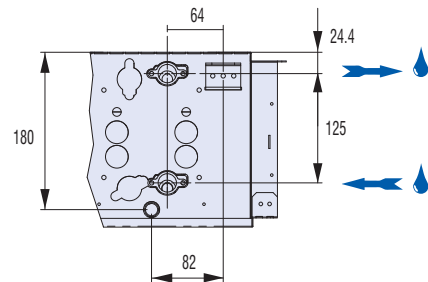
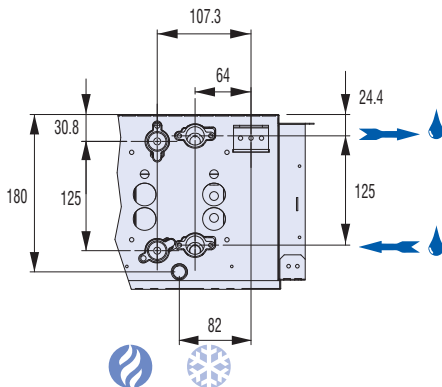
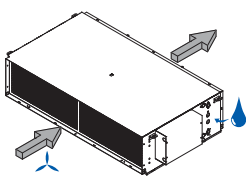
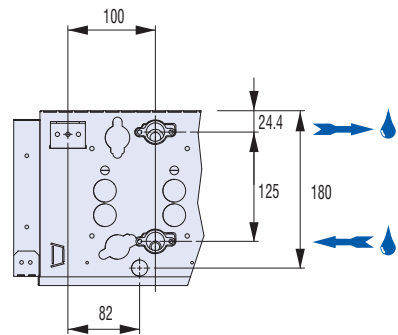
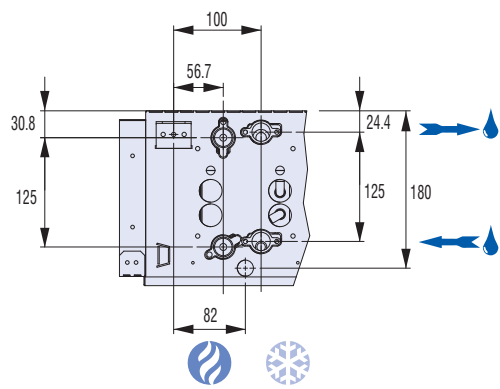
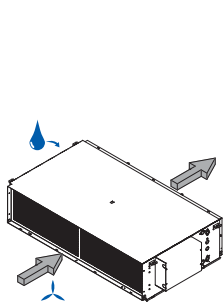
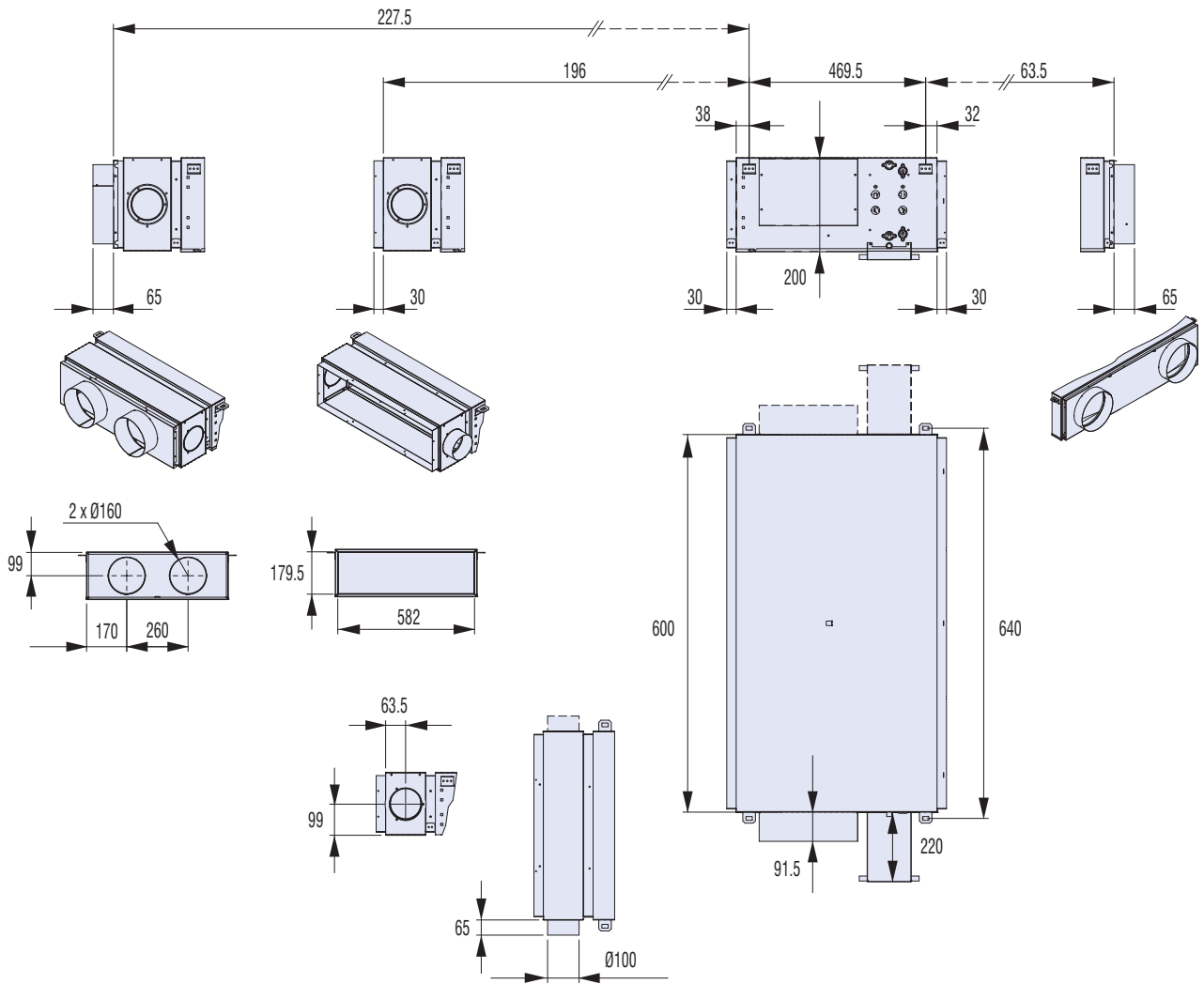

Dimensions - VH 05

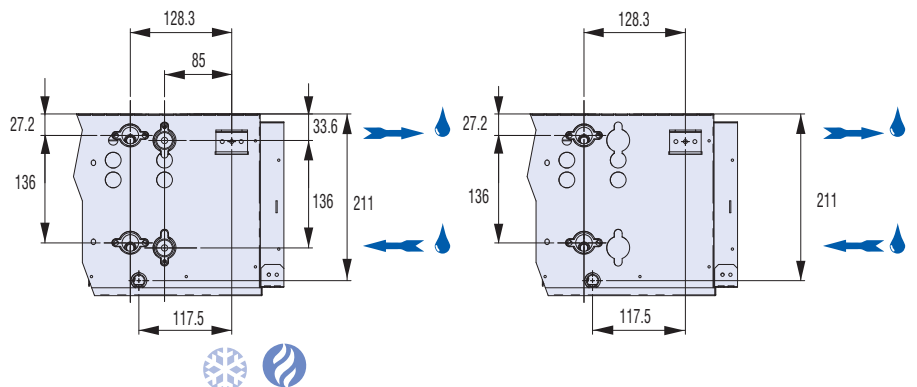
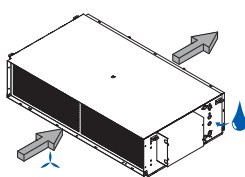
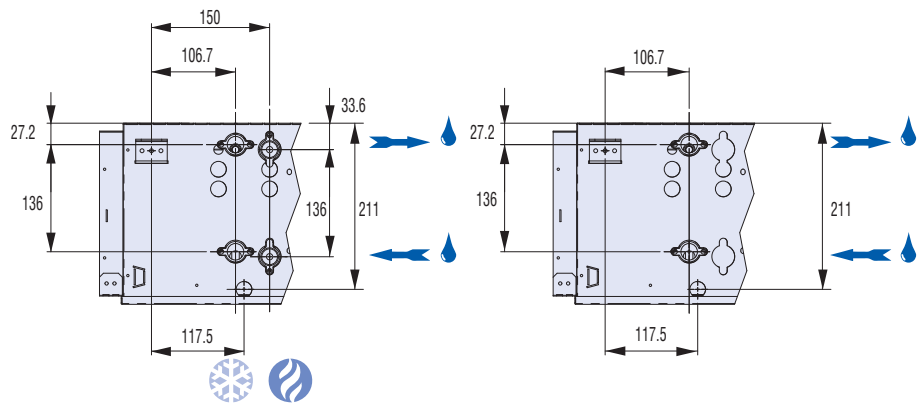
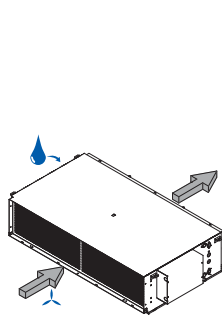
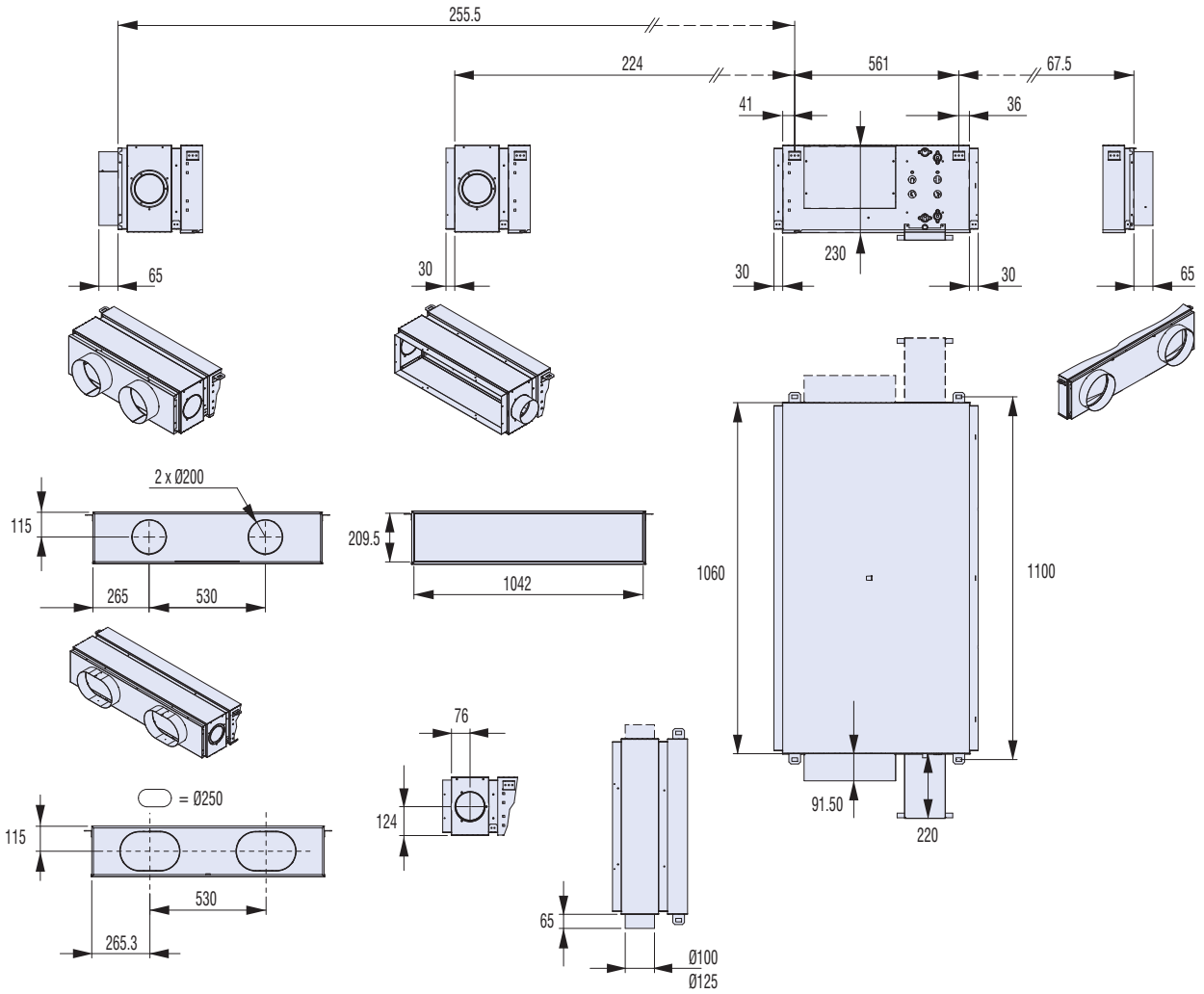

Dimensions - VH 07

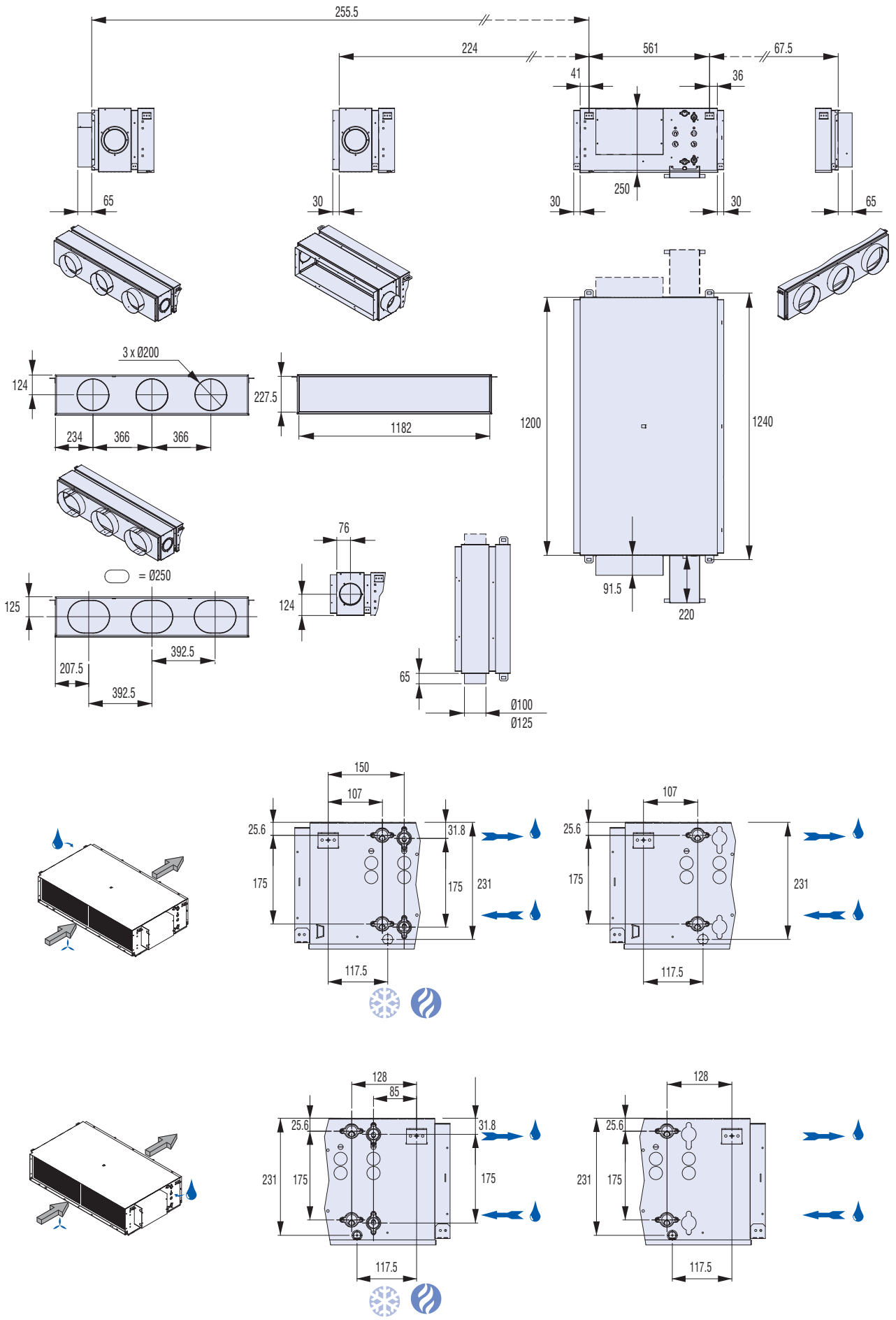

Dimensions - VH 15

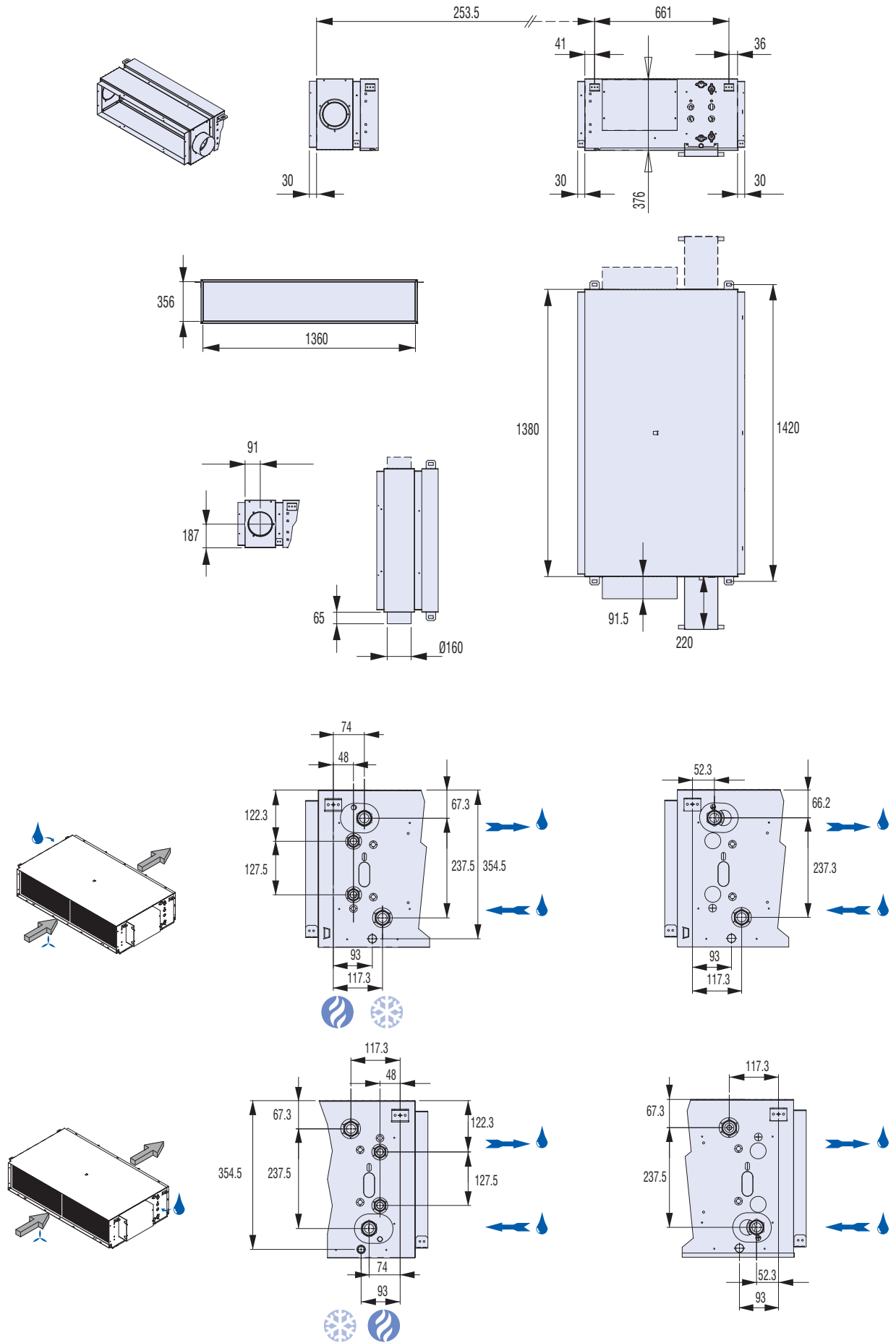

Dimensions - VH 18

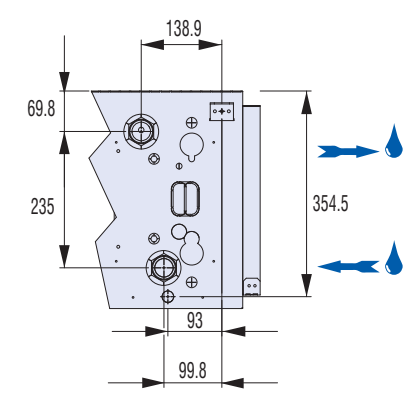
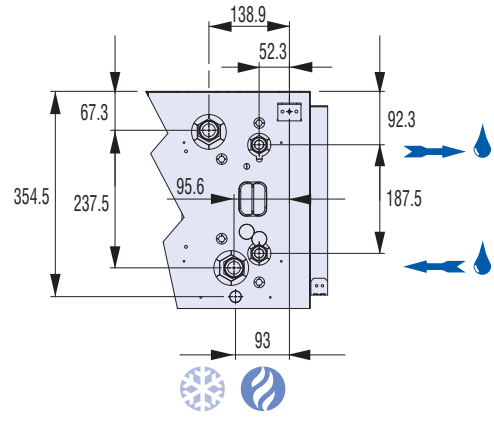
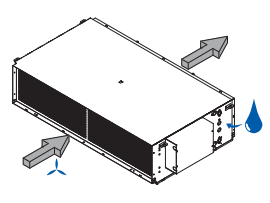
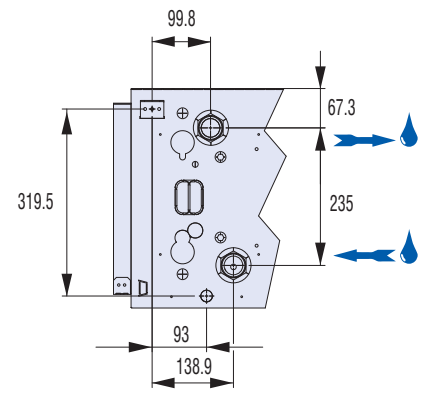
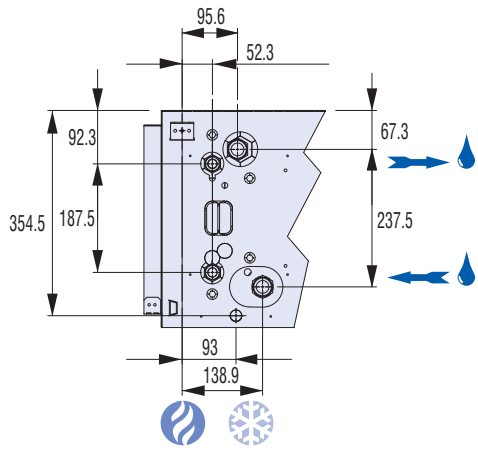
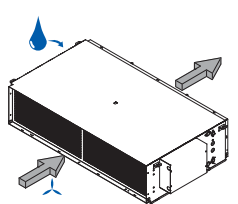
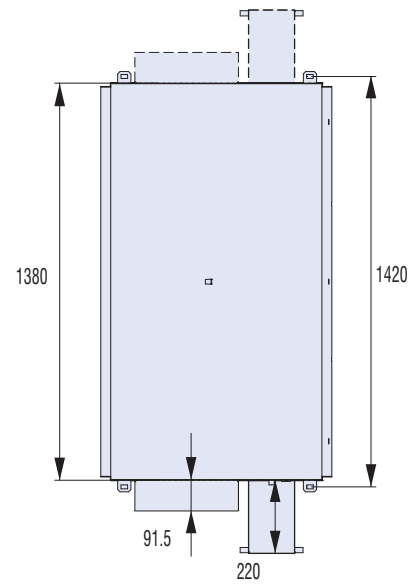
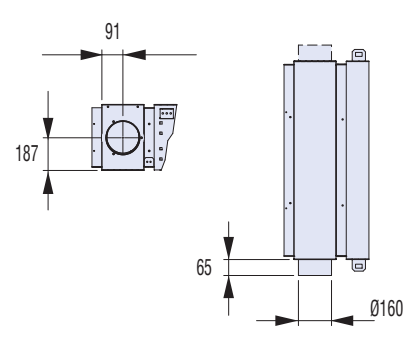
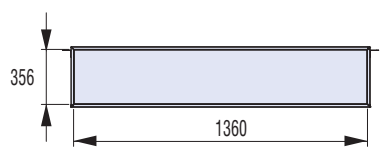
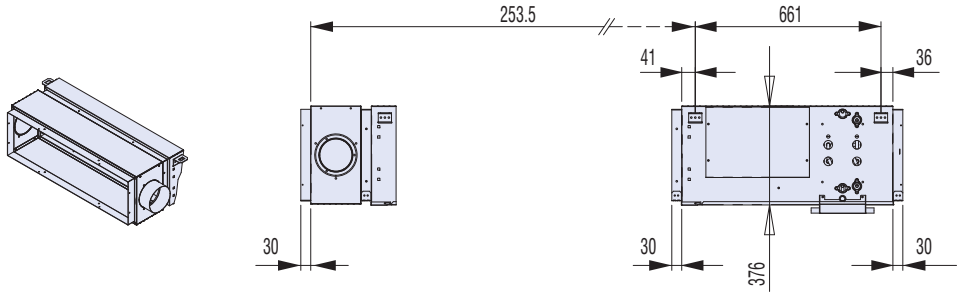

Dimensions - VH 21

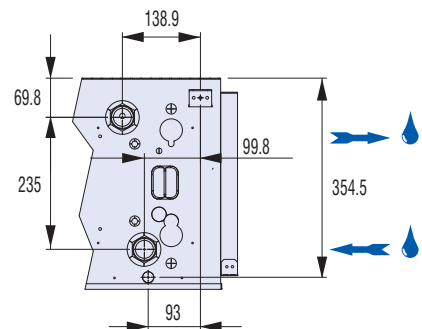
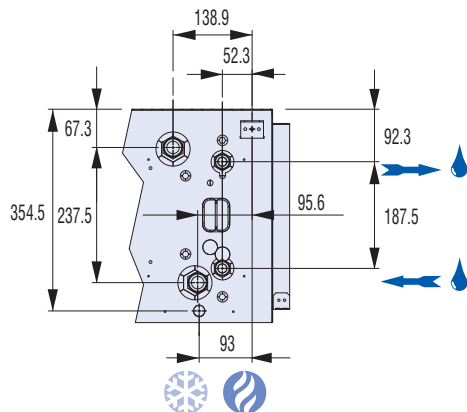
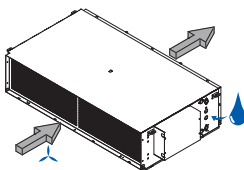
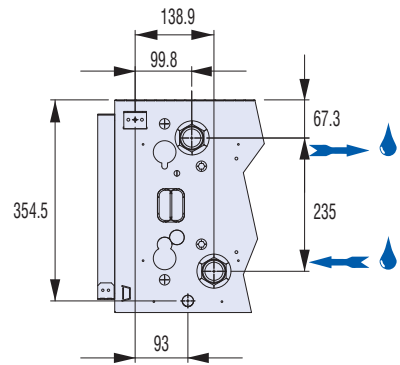
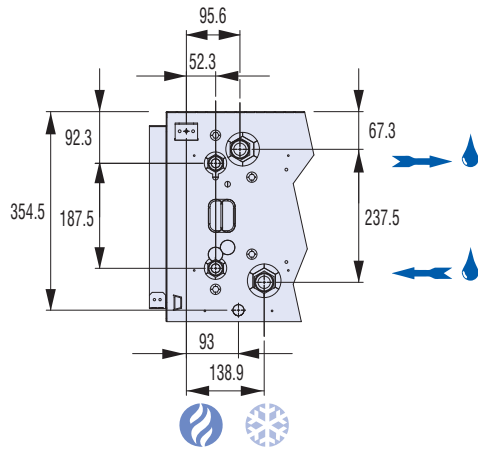
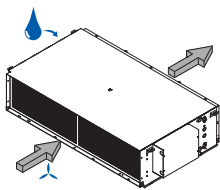
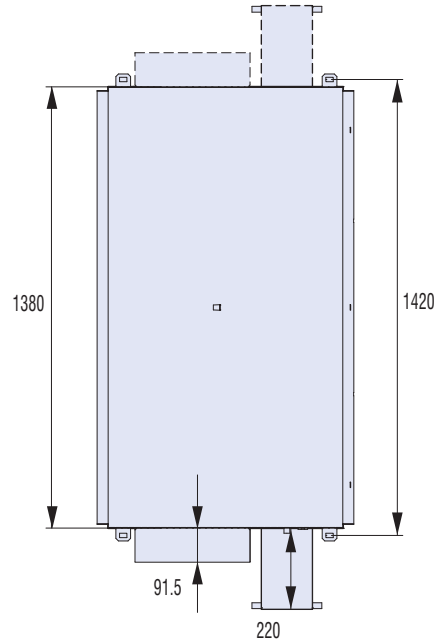
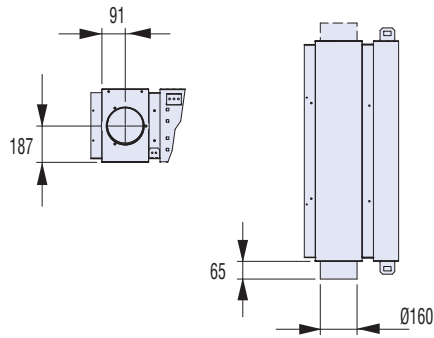
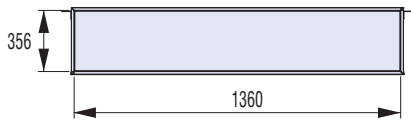
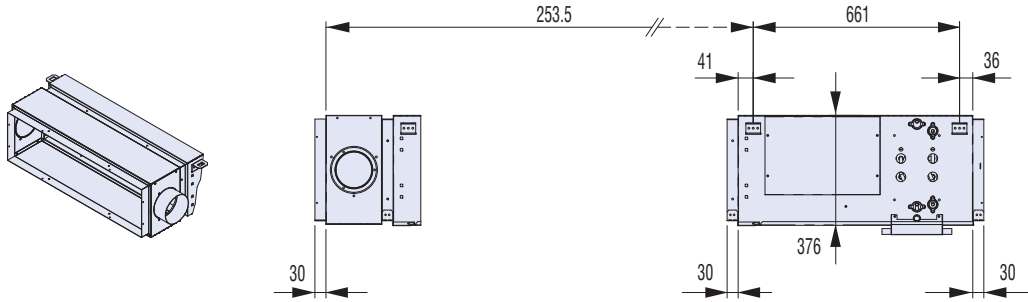

Dimensions - VH 24 and VH 27

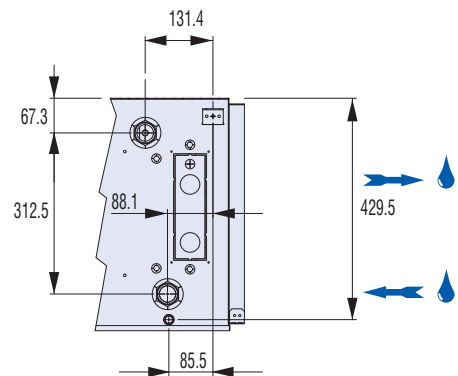
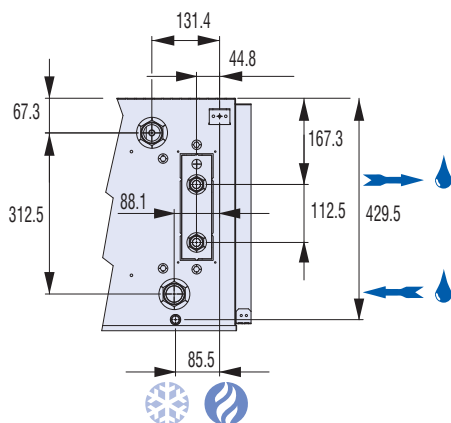
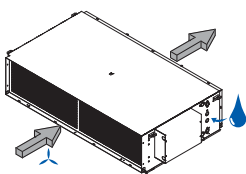
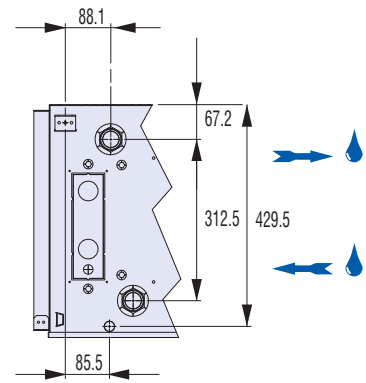
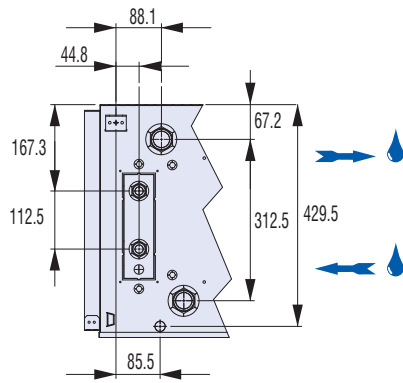
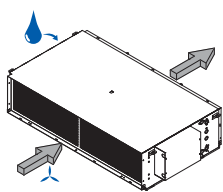
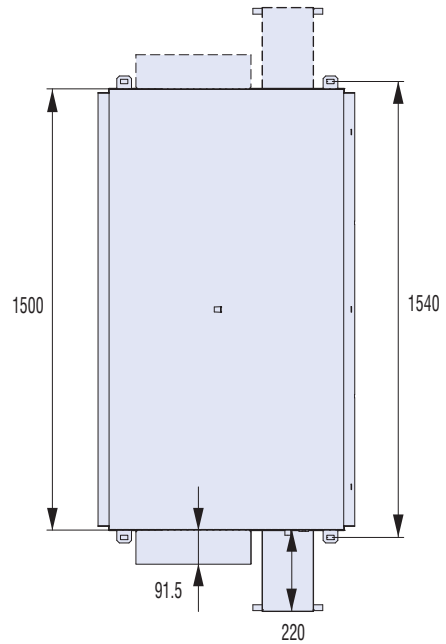
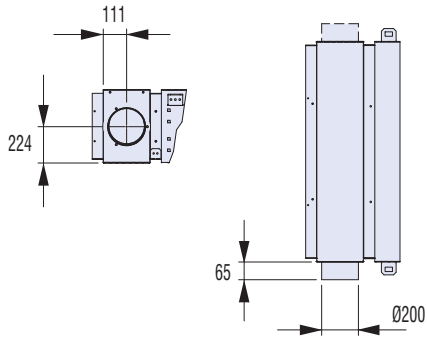
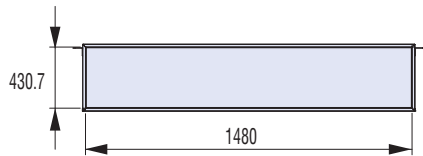
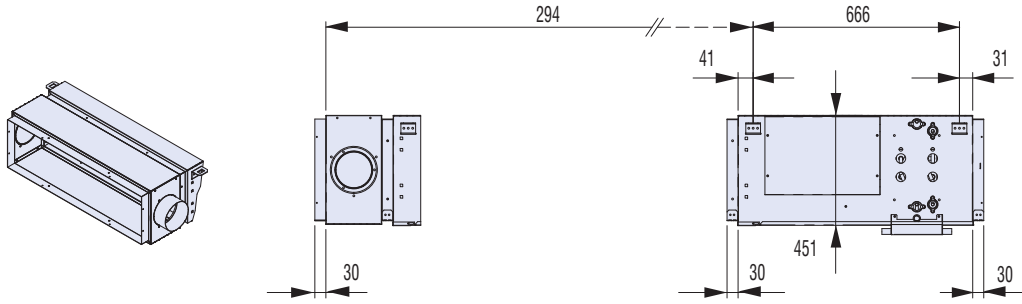

Definition of the Service Sides

The service side is determined by coil connection side when observer is looking at the unit from the discharge side.

LEFT-HAND service side

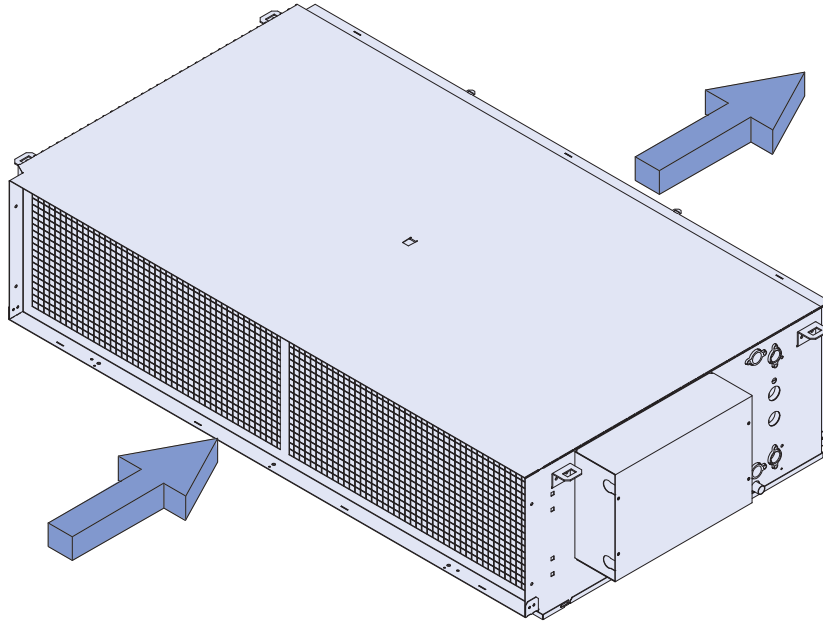

RIGHT-HAND service side

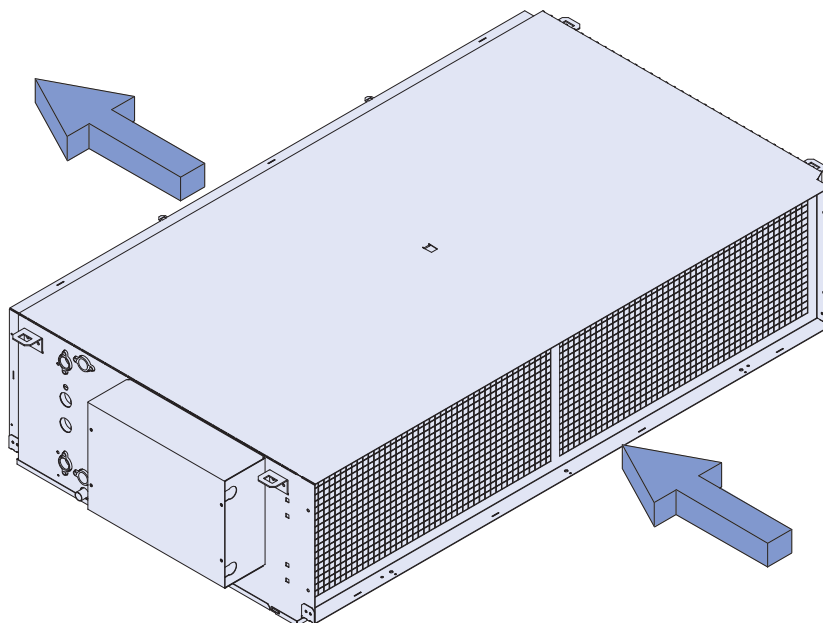

Ref. : EDM VH-A.3GB/03.11 - Supersedes : EDM VH-2GB/07.10

As part of our ongoing product improvement programme, our products are subject to change without prior notice. Non contractual photos.

AIRWELL France SAS

1bis, Avenue du 8 mai 1945
Saint Quentin en Yvelines
78284 Guyancourt Cedex
France
Tel. +33 (0) 01 39 44 78 00
Fax +33 (0) 01 39 44 65 17
www.airwell.fr

AIRWELL Italia Srl

Via XXV Aprile 29
20030 Barlassina (MI)
Italy
Tel. +39 0362 525 51
Fax +39 0362 525 690
www.airwell.it

AIRWELL Deutschland GmbH

Berner Str. 43
D-60437 Frankfurt
Germany
Tel. +49 (0) 69 50 70 21 20
Fax +49 (0) 69 50 70 22 50
www.airwell.de

AIRWELL Ibérica S.A.

Avenida Castilla, 50
28830 San Fernando de Henares
(Madrid)
Spain
Tel. +34 91 710 04 60
Fax +34 91 710 91 96
www.airwell-iberica.es

The logo for Airwell, featuring the word "Airwell" in a white, italicized, sans-serif font on a blue square background.

www.airwell.com

Airwell Group

Airwell Group (Headquarter)
1bis, Avenue du 8 mai 1945
Saint Quentin en Yvelines
78284 GUYANCOURT
France