

CWP

Water Cooled Water Chillers

Cooling Only Version (CO)
Condenserless Version (RC)
Heat Pump Version (HP)
Models 02 to 35



8 to 136 kW



9 to 164 kW



Specifications

General

The **CWP** water cooled water chillers are designed to offer **13 sizes** for all small and medium capacity residential, commercial and industrial facilities.

With the use of plate type heat exchangers, the chillers have an extremely compact design, permitting to obtain a very small foot-print.

The unit is fully encased with galvanised steel panels finished in baked paint coloured **RAL 9001**.

All chillers are designed to be located inside a plant room. Their installation is facilitated by water connections located at the rear side of the machine.

All of these 13 sizes are available in **three versions** :

- 1) **CWP-CO : "cooling only" chillers** require a cooling tower or dry cooler for heat rejection.
- 2) **CWP-RC : "condenserless" chillers** require a remote air cooled condenser for heat rejection.
- 3) **CWP-HP : "water-to-water reverse cycle" heat pumps** providing the leaving hot water temperatures up to 50 °C (heating mode), useful for sanitary hot water, low temperature heating applications, etc.

All units are completely assembled with all interconnecting refrigerant piping and internal wiring ready for field installation. After assembly, a full factory run test is performed with water flowing through the evaporator and condenser to verify that each refrigerant circuit operates correctly.

They are shipped with a full refrigerant and oil charge (except CWP-RC which is shipped with nitrogen charge).

Compressors

Compressors are of hermetic Scroll, with a gas cooled motor, crankcase heater (except sizes 02 to 09) and internal motor protection. Sizes 02 to 21 have one compressor, whereas sizes 25 to 35 have two compressors.

All compressors are mounted on rubber anti-vibration pads to minimize noise and vibration transmissions.

Evaporator

Evaporator is of direct expansion type, constituted from stainless steel brazed plate type heat exchanger.

Evaporator is wrapped with an electric resistance heater cable and thermally insulated with closed cell polyurethane foam to provide freeze protection.

Condenser (except CWP-RC)

Condenser is of stainless steel brazed plate type heat exchanger.

On CWP-HP models, condenser is wrapped with an electric resistance heater cable and thermally insulated with closed cell polyurethane foam to provide freeze protection.

Refrigerant circuit

Refrigerant circuit is supplied with thermal expansion valve, filter drier, sight glass with moisture indicator, non-return valves at compressor discharge side (on size 25 to 35 only), solenoid valve (on CWP-RC only) and high and low pressure switches.

The CWP-HP models have, in addition, reverse cycle 4-port valve, non-return valves and liquid receiver.

The CWP-RC models have, in addition, liquid receiver.

Electrical panel

All electrical equipments necessary for full unit operation are located in a compartment of which the access is accomplished through the front of the unit. Access panel is held by fixing screws.

Electrical panel, in compliance with CE standards, includes main disconnect switch with externally lockable handle, compressor contactors and overload protection, control circuit fuses, evaporator thermostat, electronic temperature controller, high & low pressure switches, anti-freeze thermostat (2 pieces on CWP-HP models), anti-short cycle time delay, on/off switch and electrical junction block for power and control circuits.

Optional features

- Control circuit transformer (400 V / 230 V),
- Compressor jacket (for sizes 06 to 35 only),
- HP/LP gauges,
- Hour counter,
- Water pressure switch (supplied loose),
- Flow switch (supplied loose),
- Water filter (supplied loose),
- ModBus protocol kit for BMS (supplied loose),
- Bacnet protocol kit for BMS (supplied loose),
- AVM kit (supplied loose),
- Condenser pressostatic valves (supplied loose),
- Water valve In-Out (supplied loose),
- Remote ON/OFF (supplied loose).
- Soft starter.
- Sequencer for up to 4 chiller installation.

Controls

The CWP units are equipped with a microprocessor based controller consisting of electronic board(s) and a user interface with digital display and programming keypad to keep the units under total control.

Interfacing panel of the controller



The meaning of each key, in the different modes, is summed up in the table below.

Button	Unit status	Button press mode
Prg <i>mute</i>	Loading default values	Press at power ON
	Go up a sub-group inside the programming area, until exiting (saving changes to EEPROM)	Press once
	In the event of alarms, mute the buzzer (if present) and deactivate the alarm relay	Press once
Sel	Access the direct parameters	Press for 5 s
	Select item inside the programming area and display value of direct parameters/confirm the changes to the parameters	Press once
Prg <i>mute</i> Sel	Program parameters after entering password	Press for 5 s
▲ ☀	Select top item inside the programming area	Press once or press and hold
	Increase value	Press once or press and hold
▼ ❄	Select bottom item inside the programming area	Press once or press and hold
	Decrease value	Press once or press and hold
▲ ☀ ▼ ❄	Manual alarm reset	Press for 5 s
	Immediately reset the hour counter (inside the programming area)	Press for 5 s

Symbol	Colour	Meaning		Reference refrigerant circuit
		With LED ON	With LED flashing	
1;2	Amber	Compressor 1 and/or 2 ON	Start up request	1
3;4	Amber	Compressor 3 and/or 4 ON	Start up request	2
⊖	Amber	At least one compressor ON		1/2
▶	Amber	Pump/air outlet fan ON	Start up request	1/2
⊗	Amber	Condenser fan ON		1/2
❄	Amber	Defrost active	Defrost request	1/2
⚡	Amber	Heater ON		1/2
🔔	Red	Alarm active		1/2
❄	Amber	Heat pump mode (P6=0)	Heat pump mode request (P6=0)	1/2
☀	Amber	Chiller mode (P6=0)	Chiller mode request (P6=0)	1/2

Refrigerant Flow Diagrams - CWP 02 to 21

CO VERSION

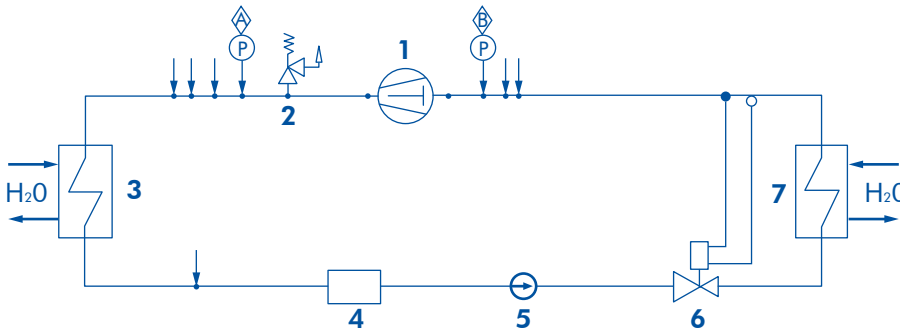

1. Compressor
2. Safety valve (from size 06)
3. Condenser
4. Drier filter
5. Sight glass
6. Thermostatic valve
7. Evaporator

RC VERSION

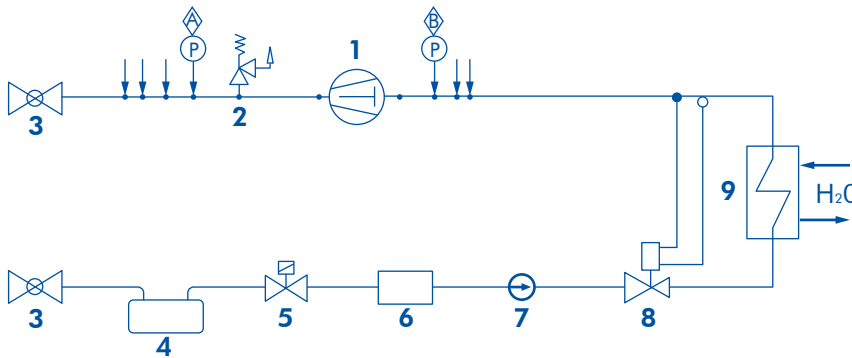

1. Compressor
2. Safety valve (from size 06)
3. Globe valve
4. Liquid receiver
5. Solenoid valve
6. Drier filter
7. Sight glass
8. Thermostatic valve
9. Evaporator

HP VERSION

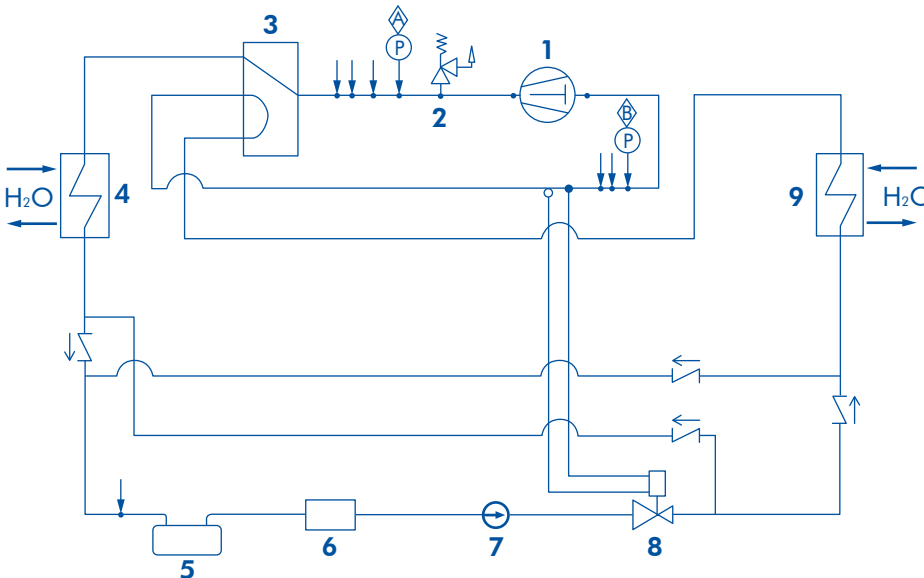

1. Compressor
2. Safety valve (from size 06)
3. 4-way valve
4. Heat exchanger
5. Liquid receiver
6. Drier filter
7. Sight glass
8. Thermostatic valve
9. Evaporator

LEGEND

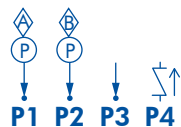

- P1. High pressure switch
- P2. Low pressure switch
- P3. Tapping point
- P4. Check valve

Refrigerant Flow Diagrams - CWP 25 to 35

CO VERSION

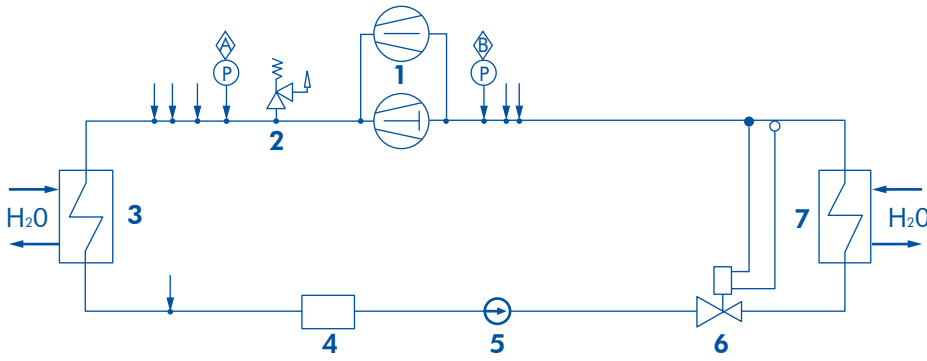

1. Compressors
2. Safety valve
3. Condenser
4. Drier filter
5. Sight glass
6. Thermostatic valve
7. Evaporator

RC VERSION

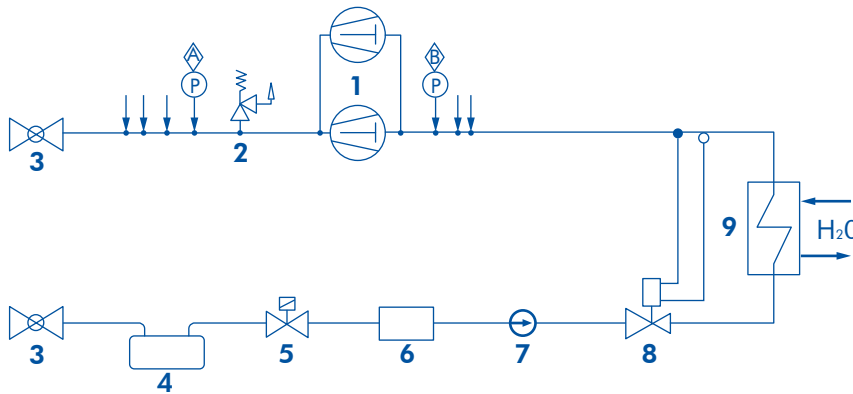

1. Compressors
2. Safety valve
3. Globe valve
4. Liquid receiver
5. Solenoid valve
6. Drier filter
7. Sight glass
8. Thermostatic valve
9. Evaporator

HP VERSION

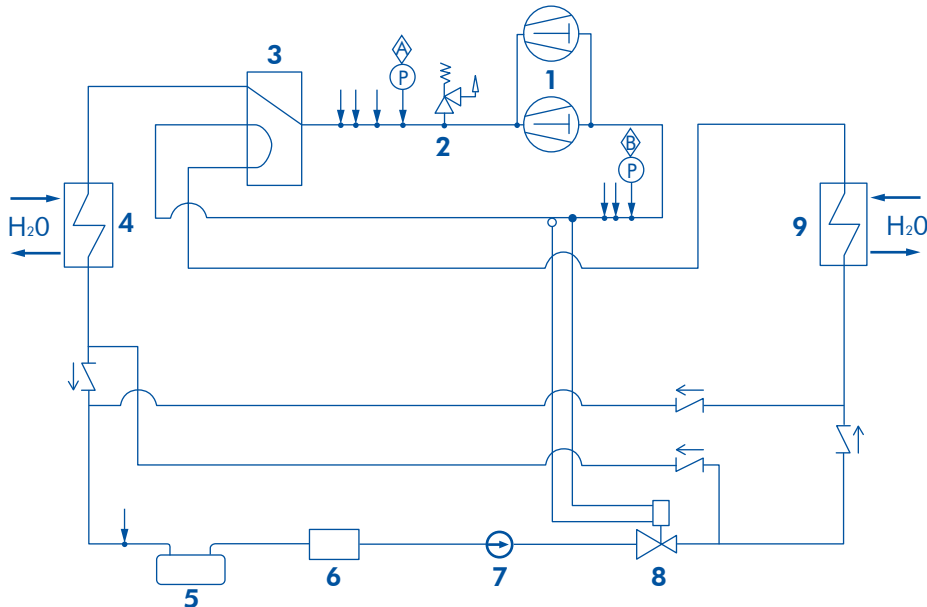

1. Compressors
2. Safety valve
3. 4-way valve
4. Heat exchanger
5. Liquid receiver
6. Drier filter
7. Sight glass
8. Thermostatic valve
9. Evaporator

LEGEND

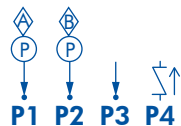

- P1. High pressure switch
- P2. Low pressure switch
- P3. Tapping point
- P4. Check valve

Operating Limits

CWP	Minimum	Maximum
Evaporator water leaving temperature (with glycol/without glycol)	-5/6	15
Evaporator water ΔT	4	6
Condenser leaving water temperature	25	50
Condenser water ΔT	5	7

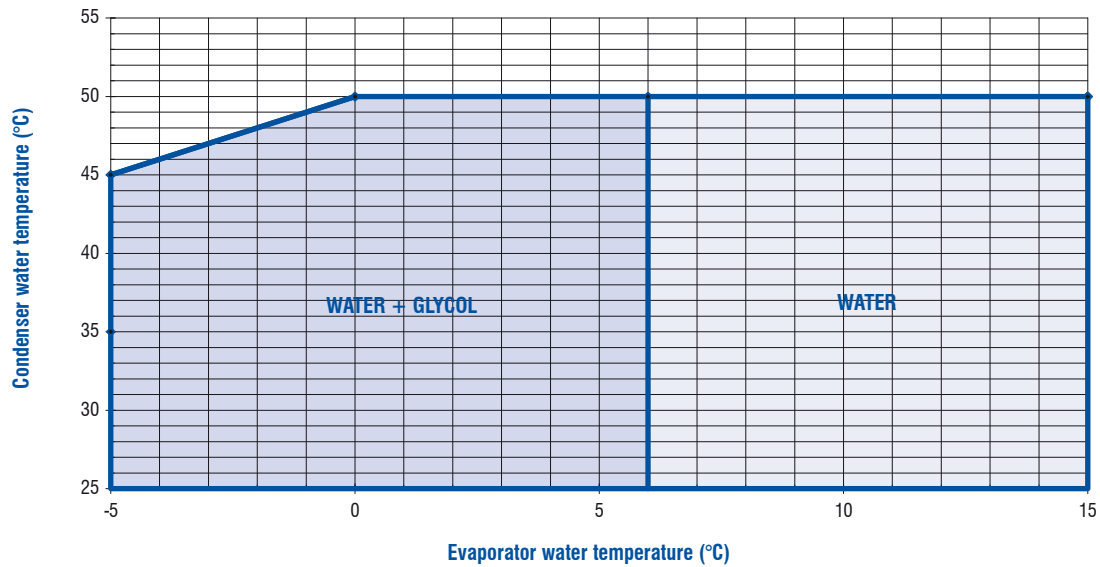

Application Adjustment Factors

Fouling Factors

Fouling factors $m^2 \cdot ^\circ C/kW$	Correction factors	
	Cooling capacity	Power input
0.044	1.000	1.000
0.088	0.987	0.995
0.176	0.964	0.985
0.352	0.915	0.962

Glycol Factors

% glycol by weight	10	20	30	40	50
Freezing point (°C)	-3	-8	-14	-22	-33
Cooling capacity	0.991	0.982	0.972	0.961	0.946
Power input	0.996	0.992	0.986	0.976	0.966
Water flow rate	1.013	1.040	1.074	1.121	1.178
Water pressure drop	1.070	1.129	1.181	1.263	1.308

Technical Data - CWP-CO

CWP-CO MODELS		02	03	04	05	06	07	09	15
Nominal cooling capacity (1)	kW	7.6	9.2	13.3	16.3	19.7	28.0	33.7	40.7
Nominal power input (1)	kW	1.97	2.38	3.37	3.91	5.08	7.16	8.76	10.9
Number of refrigerant circuit		1	1	1	1	1	1	1	1
Refrigerant charge HFC 407C	kg	1.45	1.6	1.75	2.0	2.7	2.8	2.9	4.5
COMPRESSOR									
Type / Number		Scroll / 1	Scroll / 1	Scroll / 1	Scroll / 1	Scroll / 1	Scroll / 1	Scroll / 1	Scroll / 1
No of capacity reduction steps		1	1	1	1	1	1	1	1
EVAPORATOR									
Type		Plate	Plate	Plate	Plate	Plate	Plate	Plate	Plate
Number / Water volume	litres	1 / 0.7	1 / 1.1	1 / 1.1	1 / 1.7	1 / 1.7	1 / 2.2	1 / 2.2	1 / 2.8
Inlet water connection (female gas threaded)		1"1/4	1"1/4	1"1/4	1"1/4	1"1/4	1"1/4	1"1/4	1"1/4
Outlet water connection (female gas threaded)		1"1/4	1"1/4	1"1/4	1"1/4	1"1/4	1"1/4	1"1/4	1"1/4
CONDENSER									
Type		Plate	Plate	Plate	Plate	Plate	Plate	Plate	Plate
Number / Water volume	litres	1 / 0.7	1 / 1.1	1 / 1.1	1 / 1.7	1 / 1.7	1 / 2.2	1 / 2.2	1 / 2.8
Inlet water connection (female gas threaded)		1"1/4	1"1/4	1"1/4	1"1/4	1"1/4	1"1/4	1"1/4	1"1/4
Outlet water connection (female gas threaded)		1"1/4	1"1/4	1"1/4	1"1/4	1"1/4	1"1/4	1"1/4	1"1/4
DIMENSIONS AND WEIGHT									
Length	mm	800	800	800	800	900	900	900	1100
Width	mm	600	600	600	600	700	700	700	850
Height	mm	1010	1010	1010	1010	1010	1010	1010	1110
Shipping weight	kg	115	119	125	138	185	197	201	270
Operating weight	kg	116	120	127	140	188	200	205	274

(1) Data based on chilled water temperatures of 12/7 °C and condenser water temperatures of 30/35 °C.

CWP-CO MODELS		18	21	25	30	35
Nominal cooling capacity (1)	kW	55.8	67.6	87.7	111.9	136.2
Nominal power input (1)	kW	14.1	18.0	23.1	28.3	35.9
Number of refrigerant circuit		1	1	1	1	1
Refrigerant charge HFC 407C	kg	4.5	5.0	8.5	9.0	11.2
COMPRESSORS						
Type / Number		Scroll / 1	Scroll / 1	Scroll / 2	Scroll / 2	Scroll / 2
N° of capacity steps		1	1	2	2	2
EVAPORATOR						
Type		Plate	Plate	Plate	Plate	Plate
Number / Water volume	litres	1 / 4.4	1 / 5.3	1 / 6.9	1 / 8.6	1 / 10.9
Inlet water connection (female gas threaded)		1"1/4	1"1/4	2"	2"	2"
Outlet water connection (female gas threaded)		1"1/4	1"1/4	2"	2"	2"
CONDENSER						
Type		Plate	Plate	Plate	Plate	Plate
Number / Water volume	litres	1/4.4	1/5.3	1/6.9	1/8.6	1/10.9
Inlet water connection (female gas threaded)		1"1/4	1"1/4	2"	2"	2"
Outlet water connection (female gas threaded)		1"1/4	1"1/4	2"	2"	2"
DIMENSIONS AND WEIGHT						
Length	mm	1100	1100	1700	1700	1700
Height	mm	1110	1110	1210	1210	1210
Width	mm	850	850	984	984	984
Shipping weight	kg	290	300	500	530	560
Operating weight	kg	295	306	508	541	574

(1) Data based on chilled water temperatures of 12/7 °C and condenser water temperatures of 30/35 °C.

Technical Data - CWP-HP

CWP-HP MODELS		02	03	04	05	06	07	09	15
Nominal cooling capacity (1)	kW	7.6	9.2	13.3	16.3	19.7	28.0	33.7	40.7
Nominal power input (1)	kW	2.0	2.4	3.4	3.9	5.1	7.2	8.8	10.9
Nominal heating capacity (2)	kW	9.0	10.7	15.7	19.0	23.3	33.2	40.1	49.1
Nominal power input (2)	kW	2.58	2.97	4.33	5.06	6.51	9.21	11.20	13.9
Number of refrigerant circuit		1	1	1	1	1	1	1	1
Refrigerant charge HFC 407C	kg	4	4.2	4.3	4.5	5.2	5.2	8.5	8.5
COMPRESSOR									
Type / Number		Scroll / 1	Scroll / 1	Scroll / 1	Scroll / 1	Scroll / 1	Scroll / 1	Scroll / 1	Scroll / 1
No of capacity reduction steps		1	1	1	1	1	1	1	1
EVAPORATOR									
Type		Plate	Plate	Plate	Plate	Plate	Plate	Plate	Plate
Number / Water volume	litres	1 / 0.7	1 / 1.1	1 / 1.1	1 / 1.7	1 / 1.7	1 / 2.2	1 / 2.2	1 / 2.8
Inlet water connection (female gas threaded)		1"1/4	1"1/4	1"1/4	1"1/4	1"1/4	1"1/4	1"1/4	1"1/4
Outlet water connection (female gas threaded)		1"1/4	1"1/4	1"1/4	1"1/4	1"1/4	1"1/4	1"1/4	1"1/4
CONDENSER									
Type		Plate	Plate	Plate	Plate	Plate	Plate	Plate	Plate
Number / Water volume	litres	1 / 0.7	1 / 1.1	1 / 1.1	1 / 1.7	1 / 1.7	1 / 2.2	1 / 2.2	1 / 2.8
Inlet water connection (female gas threaded)		1"1/4	1"1/4	1"1/4	1"1/4	1"1/4	1"1/4	1"1/4	1"1/4
Outlet water connection (female gas threaded)		1"1/4	1"1/4	1"1/4	1"1/4	1"1/4	1"1/4	1"1/4	1"1/4
DIMENSIONS AND WEIGHT									
Length	mm	800	800	800	800	900	900	900	1100
Width	mm	600	600	600	600	700	700	700	850
Height	mm	1010	1010	1010	1010	1010	1010	1010	1110
Shipping weight	kg	127	130	137	151	204	216	222	298
Operating weight	kg	128	132	139	154	207	220	226	302

(1) Data based on chilled water temperatures of 12/7 °C and condenser water temperatures of 30/35 °C.

(2) Data based on chilled water temperatures of 12/7 °C and condenser water temperatures of 40/45 °C.

CWP-HP MODELS		18	21	25	30	35
Nominal cooling capacity (1)	kW	55.8	67.6	87.7	111.9	136.2
Nominal power input (Cooling) (1)	kW	14.1	18.0	23.1	28.3	35.9
Nominal heating capacity (2)	kW	66.7	76.1	106.3	133.7	164.1
Nominal power input (Heating) (2)	kW	17.4	22.0	28.6	34.9	44.5
Number of refrigerant circuit		1	1	1	1	1
Refrigerant charge HFC 407C	kg	9.4	15	16	17	19
COMPRESSOR						
Type / Number		Scroll / 1	Scroll / 1	Scroll / 2	Scroll / 2	Scroll / 2
N° of capacity steps		1	1	2	2	2
EVAPORATOR						
Type		Plate	Plate	Plate	Plate	Plate
Number / Water volume	litres	1 / 4.4	1 / 5.3	1 / 6.9	1 / 8.6	1 / 10.9
Inlet water connection (female gas threaded)		1"1/4	1"1/4	2"	2"	2"
Outlet water connection (female gas threaded)		1"1/4	1"1/4	2"	2"	2"
CONDENSER						
Type		Plate	Plate	Plate	Plate	Plate
Number / Water volume	litres	1 / 4.4	1 / 5.3	1 / 6.9	1 / 8.6	1 / 10.9
Inlet water connection (female gas threaded)		1"1/4	1"1/4	2"	2"	2"
Outlet water connection (female gas threaded)		1"1/4	1"1/4	2"	2"	2"
DIMENSIONS AND WEIGHT						
Length	mm	1100	1100	1700	1700	1700
Height	mm	1110	1110	1210	1210	1210
Width	mm	850	850	984	984	984
Shipping weight	kg	319	331	530	560	590
Operating weight	kg	324	337	538	571	604

(1) Data based on chilled water temperatures of 12/7 °C and condenser water temperatures of 30/35 °C.

(2) Data based on chilled water temperatures of 12/7 °C and condenser water temperatures of 40/45 °C.

Technical Data - CWP-RC

CWP-RC MODELS		02	03	04	05	06	07	09	15
Nominal cooling capacity (1)	kW	7.4	9.0	13.1	15.8	19.2	27.5	33.0	40.0
Nominal power input (1)	kW	2.1	2.4	3.6	4.2	5.5	7.7	9.4	11.7
Number of refrigerant circuit		1	1	1	1	1	1	1	1
COMPRESSOR									
Type / Number		Scroll / 1	Scroll / 1	Scroll / 1	Scroll / 1	Scroll / 1	Scroll / 1	Scroll / 1	Scroll / 1
No of capacity reduction steps		1	1	1	1	1	1	1	1
EVAPORATOR									
Type		Plate	Plate	Plate	Plate	Plate	Plate	Plate	Plate
Number / Water volume	dm ³	1 / 0.7	1 / 1.1	1 / 1.1	1 / 1.7	1 / 1.7	1 / 2.2	1 / 2.2	1 / 2.8
Inlet water connection (female gas threaded)		1"1/4	1"1/4	1"1/4	1"1/4	1"1/4	1"1/4	1"1/4	1"1/4
Outlet water connection (female gas threaded)		1"1/4	1"1/4	1"1/4	1"1/4	1"1/4	1"1/4	1"1/4	1"1/4
REFRIGERANT CONNECTIONS									
Liquid line		3/8"	1/2"	1/2"	1/2"	1/2"	5/8"	5/8"	5/8"
Discharge line		5/8"	5/8"	5/8"	5/8"	7/8"	7/8"	7/8"	1"1/8
DIMENSIONS AND WEIGHT									
Length	mm	800	800	800	800	900	900	900	1100
Width	mm	600	600	600	600	700	700	700	850
Height	mm	1010	1010	1010	1010	1010	1010	1010	1110
Shipping weight	kg	110	114	119	131	179	188	193	259

(1) Data based on chilled water temperatures of 12/7 °C and condensing temperature of 45 °C.

CWP-RC MODELS		18	21	25	30	35
Nominal cooling capacity (1)	kW	55.8	67.6	87.7	111.9	136.2
Nominal power input (1)	kW	14.1	18.0	23.1	28.3	35.9
Number of refrigerant circuit		1	1	1	1	1
COMPRESSORS						
Type / Number		Scroll / 1	Scroll / 1	Scroll / 2	Scroll / 2	Scroll / 2
N° of Capacity Steps		1	1	2	2	2
EVAPORATOR						
Type		Plate	Plate	Plate	Plate	Plate
Number / Water volume	litres	1 / 4.4	1 / 5.3	1 / 6.9	1 / 8.6	1 / 10.9
Inlet water connection (female gas threaded)		1"1/4	1"1/4	2"	2"	2"
Outlet water connection (female gas threaded)		1"1/4	1"1/4	2"	2"	2"
REFRIGERANT CONNECTIONS						
Liquid line		7/8"	7/8"	7/8"	1"1/8	1"1/8
Discharge line		1"1/8	1"1/8	1"3/8	1"5/8	1"5/8
DIMENSIONS AND WEIGHT						
Length	mm	1100	1100	1700	1700	1700
Height	mm	1110	1110	1210	1210	1210
Width	mm	850	850	984	984	984
Shipping weight	kg	279	290	471	497	520

(1) Data based on chilled water temperatures of 12/7 °C and condensing temperature of 45 °C.

Electrical Data - HFC 407C

CWP-CO / CWP-HP / CWP-RC Models		02	03	04	05	06	07	09	15
Nominal voltage	V(%)ph/Hz	230/1/50	400 ± 10% / 3 / 50						
Max. power input	kW	2.3	2.7	4	4.6	6	8.5	10.4	12.9
Max. current (FLA)	A	17.3	6.5	9.7	11.3	14.7	20	24.5	29
Max. start-up current (LRA)	A	76	46	66	74	99	127	167	198

CWP-CO / CWP-HP / CWP-RC Models		18	21	25	30	35
Nominal voltage	V(%)ph/Hz	400 ± 10% / 3 / 50				
Max. power input	kW	24.2	28.1	32.9	44.5	56.2
Max. current (FLA)	A	41	47.5	55.6	75.3	95
Max. start-up current (LRA)	A	225	272	226	300	320

Sound Data

CWP	FREQUENCY (Hz)							Sound Power dB(A)
	125	250	500	1000	2000	4000	8000	
02	Not available							
03								
04								
05								
06	46	62	63	61	60	52	40	72
07	49	65	66	64	63	55	43	73
09	52	68	69	67	66	58	46	75
15	55	71	72	70	69	61	49	75
18	58	74	75	73	72	64	52	78*
21	58	74	75	73	72	64	52	78*
25	58	74	75	73	72	64	52	78*
30	59	75	76	74	73	65	53	79*
35	61	77	78	76	75	67	55	81*

* With jackets, consider this data minus 4 dBA. Total A weighted sound power level given with tolerance of ± 2 dB(A).

CWP	FREQUENCY (Hz)							Sound Pressure at 1 mt* dB(A)
	125	250	500	1000	2000	4000	8000	
02	Not available							
03								
04								
05								
06	31,1	46,8	47,9	46,3	44,8	37,4	25,4	57
07	34,1	49,8	50,9	49,3	47,8	40,4	28,4	58
09	37,1	52,8	53,9	52,3	50,8	43,4	31,4	60
15	40,1	55,8	56,9	55,3	53,8	46,4	34,4	60
18	43,1	58,8	59,9	58,3	56,8	49,4	37,4	63*
21	43,1	58,8	59,9	58,3	56,8	49,4	37,4	63*
25	42,1	57,8	58,9	57,3	55,8	48,4	36,4	62*
30	43,1	58,8	59,9	58,3	56,8	49,4	37,4	63*
35	45,1	60,8	61,9	60,3	58,8	51,4	39,4	65*

* With jackets, consider this data minus 4 dBA.

Performance Data - CWP-CO with HFC 407C

Unit size	Leav. chilled water temp. (°C)	CONDENSER LEAVING WATER TEMPERATURE (°C)													
		26 °C		33 °C		35 °C		37 °C		39 °C		41 °C		46 °C	
		Cool. capa. kW	Power input kW	Cool. capa. kW	Power input kW	Cool. capa. kW	Power input kW	Cool. capa. kW	Power input kW	Cool. capa. kW	Power input kW	Cool. capa. kW	Power input kW	Cool. capa. kW	Power input kW
CWP 02 CO	6	8.0	1.6	7.5	1.9	7.3	2.0	7.1	2.1	7.0	2.2	6.8	2.3	6.3	2.6
	7	8.3	1.6	7.7	1.9	7.6	2.0	7.4	2.1	7.2	2.2	7.0	2.3	6.5	2.6
	8	8.6	1.6	8.0	1.9	7.8	2.0	7.6	2.1	7.4	2.2	7.3	2.3	6.8	2.6
	9	8.8	1.6	8.3	1.9	8.1	2.0	7.9	2.1	7.7	2.2	7.5	2.3	7.0	2.6
CWP 03 CO	10	9.1	1.6	8.5	1.9	8.3	2.0	8.1	2.1	8.0	2.2	7.8	2.3	7.2	2.6
	6	9.6	1.8	9.0	2.1	8.9	2.4	8.6	2.4	8.4	2.5	8.2	2.6	7.6	3.0
	7	9.9	1.8	9.3	2.1	9.2	2.4	8.9	2.4	8.7	2.5	8.5	2.6	7.9	3.0
	8	10.3	1.8	9.6	2.2	9.5	2.4	9.2	2.4	9.0	2.5	8.8	2.6	8.2	3.0
CWP 04 CO	9	10.6	1.8	10.0	2.2	9.8	2.4	9.5	2.4	9.3	2.5	9.1	2.7	8.4	3.0
	10	10.7	1.8	10.3	2.2	10.0	2.4	9.9	2.4	9.6	2.5	9.4	2.7	8.8	3.1
	6	14.1	2.7	13.1	3.2	12.8	3.3	12.5	3.5	12.2	3.7	11.9	3.8	11.1	4.3
	7	14.6	2.8	13.6	3.2	13.3	3.4	13.0	3.5	12.7	3.7	12.4	3.9	11.5	4.3
CWP 05 CO	8	15.0	2.8	14.1	3.3	13.7	3.4	13.4	3.6	13.1	3.7	12.8	3.9	11.9	4.4
	9	15.5	2.8	14.5	3.3	14.2	3.4	13.9	3.6	13.6	3.8	13.2	3.9	12.3	4.4
	10	16.0	2.8	15.0	3.3	14.7	3.5	14.4	3.6	14.0	3.8	13.7	4.0	12.8	4.4
	6	17.4	3.2	16.2	3.7	15.8	3.9	15.4	4.1	15.0	4.3	14.7	4.5	13.7	5.0
CWP 06 CO	7	18.0	3.2	16.7	3.7	16.3	3.9	15.9	4.1	15.5	4.3	15.1	4.5	14.2	5.1
	8	18.6	3.2	17.2	3.8	16.9	3.9	16.4	4.1	16.1	4.3	15.6	4.5	14.6	5.1
	9	19.2	3.2	17.8	3.8	17.4	4.0	17.0	4.2	16.6	4.4	16.1	4.6	15.1	5.1
	10	19.8	3.3	18.4	3.8	18.0	4.0	17.5	4.2	17.1	4.4	16.7	4.6	15.6	5.2
CWP 07 CO	6	20.9	4.1	19.5	4.8	19.0	5.1	18.6	5.3	18.2	5.5	17.7	5.8	16.5	6.5
	7	21.6	4.2	20.1	4.9	19.7	5.1	19.2	5.3	18.8	5.6	18.3	5.8	17.1	6.5
	8	22.3	4.2	20.8	4.9	20.3	5.1	19.9	5.4	19.4	5.6	18.9	5.9	17.7	6.6
	9	23.0	4.2	21.5	4.9	21.0	5.2	20.5	5.4	20.0	5.6	19.5	5.9	18.3	6.6
CWP 08 CO	10	23.8	4.2	22.2	5.0	21.7	5.2	21.2	5.4	20.7	5.7	20.2	5.9	18.8	6.7
	6	29.8	5.8	27.7	6.8	27.1	7.1	26.5	7.5	25.8	7.8	25.2	8.2	23.6	9.2
	7	30.8	5.8	28.6	6.8	28.0	7.2	27.3	7.5	26.7	7.9	26.1	8.2	24.4	9.2
	8	31.8	5.8	29.6	6.9	29.0	7.2	28.3	7.5	27.6	7.9	27.0	8.3	25.3	9.3
CWP 09 CO	9	32.6	5.9	30.6	6.9	29.9	7.2	29.2	7.6	28.6	8.0	27.9	8.3	26.1	9.3
	10	33.9	5.9	31.6	7.0	30.9	7.3	30.2	7.6	29.5	8.0	28.8	8.4	27.0	9.4
	6	35.7	7.2	33.4	8.3	32.6	8.7	31.9	9.1	31.3	9.5	30.4	9.9	28.5	11.1
	7	36.8	7.2	34.4	8.4	33.7	8.8	32.9	9.2	32.2	9.6	31.4	10.0	29.4	11.2
CWP 10 CO	8	38.2	7.3	35.7	8.5	34.9	8.8	34.1	9.2	33.3	9.7	32.5	10.1	30.4	11.3
	9	39.5	7.4	36.8	8.6	36.1	8.9	35.3	9.3	34.5	9.8	33.6	10.2	31.5	11.4
	10	40.9	7.5	38.2	8.6	37.3	9.0	36.5	9.4	35.6	9.8	34.8	10.3	32.6	11.5
	6	43.1	8.9	40.3	10.3	39.5	10.8	38.6	11.3	37.8	11.8	36.9	12.3	34.7	13.8
CWP 11 CO	7	44.4	8.9	41.6	10.4	40.7	10.9	40.0	11.3	39.0	11.9	38.2	12.4	35.9	13.9
	8	45.8	9.0	42.6	10.4	42.0	10.9	41.1	11.4	40.2	11.9	39.4	12.5	37.0	13.9
	9	47.2	9.0	44.2	10.5	43.4	11.0	42.5	11.5	41.6	12.0	40.6	12.5	38.2	14.0
	10	48.7	9.1	45.6	10.5	44.7	11.0	43.8	11.5	42.9	14.8	42.0	12.6	39.4	14.1
CWP 12 CO	6	61.5	12.7	55.0	13.7	53.3	13.9	51.5	14.2	49.7	14.4	47.9	14.7	43.7	15.2
	7	64.3	12.8	57.7	13.9	55.8	14.1	54.0	14.3	52.1	14.6	50.4	14.9	45.9	15.5
	8	67.1	13.0	60.3	14.1	58.4	14.3	56.5	14.5	54.6	14.9	52.8	15.1	48.2	15.7
	9	69.9	13.1	62.9	14.3	60.9	14.4	59.0	14.8	57.0	15.0	55.2	15.4	50.4	16.1
CWP 13 CO	10	72.8	13.2	65.5	14.4	63.5	14.6	61.5	15.0	59.5	15.3	57.6	15.6	52.6	16.3
	6	74.2	16.0	66.8	17.3	64.6	17.7	62.6	18.0	60.4	18.4	58.4	18.7	53.2	19.5
	7	77.4	16.2	69.7	17.6	67.6	18.0	65.4	18.3	63.3	18.7	61.1	19.0	55.8	19.8
	8	80.6	16.4	72.7	17.8	70.5	18.2	68.3	18.6	66.0	18.9	63.8	19.3	58.4	20.2
CWP 14 CO	9	83.9	16.5	75.8	18.0	73.4	18.4	71.2	18.8	68.8	19.2	66.6	19.6	60.9	20.5
	10	87.3	16.6	78.8	18.2	76.4	18.7	74.0	19.1	71.6	19.5	69.3	19.9	63.5	20.9
	6	99.3	20.5	86.6	22.4	83.2	22.8	79.8	23.2	76.4	23.8	73.2	24.1	65.3	25.0
	7	103.9	20.7	91.2	22.7	87.7	23.1	84.2	23.7	80.7	24.1	77.3	24.5	69.0	25.4
CWP 15 CO	8	108.8	20.9	95.8	23.0	92.2	23.6	88.6	24.1	84.9	24.5	81.5	24.9	72.9	25.9
	9	113.8	21.1	100.5	23.3	96.7	23.9	93.0	24.4	89.2	24.9	85.6	25.3	76.7	26.4
	10	118.9	21.3	105.1	23.7	101.2	24.2	97.3	24.8	93.5	25.3	89.7	25.8	80.5	26.9
	6	123.5	25.5	110.4	27.6	106.8	28.0	103.2	28.5	99.7	29.0	96.2	29.4	87.5	30.6
CWP 16 CO	7	128.9	25.8	115.6	28.0	111.9	28.3	108.2	28.8	104.6	29.4	101.1	29.9	92.0	31.2
	8	134.5	26.0	120.8	28.3	117.0	28.6	113.2	29.3	109.6	29.9	105.9	30.4	96.5	31.7
	9	140.1	26.2	126.1	28.6	122.2	29.0	118.4	29.7	114.5	30.3	110.7	30.8	101.1	32.2
	10	145.9	26.5	131.4	28.9	127.3	29.4	123.4	30.0	119.4	30.7	115.5	31.3	105.7	32.7
CWP 17 CO	6	149.8	32.1	134.6	34.6	130.3	35.4	126.1	36.1	121.8	36.8	117.7	37.4	107.5	38.9
	7	156.1	32.4	140.7	35.1	136.2	35.9	131.9	36.6	127.5	37.3	123.3	38.0	112.6	39.6
	8	162.6	32.7	146.8	35.5	142.2	36.3	137.7	37.1	133.2	37.9	128.8	38.6	117.7	40.3
	9	169.3	33.1	152.9	36.0	148.1	36.9	143.5	37.6	138.8	38.4	134.3	39.2	122.9	40.9
CWP 18 CO	10	176.1	33.3	159.0	36.4	154.1	37.3	149.3	38.2	144.5	39.0	139.7	39.8	128.1	41.6

Performance Data - CWP-HP with HFC 407C

Unit size	Leav. chilled water temp. (°C)	CONDENSER LEAVING WATER TEMPERATURE (°C)															
		25 °C		32 °C		35 °C		36 °C		38 °C		40 °C		45 °C		50 °C	
		Heat. capa. kW	Power input kW	Heat. capa. kW	Power input kW	Heat. capa. kW	Power input kW	Heat. capa. kW	Power input kW	Heat. capa. kW	Power input kW	Heat. capa. kW	Power input kW	Heat. capa. kW	Power input kW	Heat. capa. kW	Power input kW
CWP 02 HP	6	9.5	1.4	9.2	1.8	9.2	2.0	9.0	2.0	9.0	2.2	8.9	2.3	8.8	2.6	8.6	2.9
	7	9.6	1.4	9.4	1.8	9.4	2.0	9.3	2.0	9.3	2.2	9.2	2.3	9.0	2.6	8.8	3.0
	8	10.0	1.4	9.7	1.8	9.7	2.0	9.5	2.0	9.5	2.2	9.4	2.3	9.2	2.6	9.0	3.0
	9	10.3	1.4	10.0	1.8	10.0	2.0	9.8	2.0	9.8	2.2	9.7	2.3	9.5	2.6	9.3	3.0
CWP 03 HP	6	11.5	1.9	11.1	2.2	11.1	2.4	10.9	2.3	10.8	2.5	10.7	2.6	10.4	3.0	10.2	3.4
	7	12.1	1.9	11.5	2.2	11.5	2.4	11.1	2.3	11.0	2.5	10.9	2.6	10.7	3.0	10.4	3.4
	8	12.3	1.9	11.8	2.2	11.8	2.4	11.5	2.4	11.4	2.5	11.3	2.6	11.0	3.0	10.7	3.4
	9	12.6	1.9	12.1	2.2	12.1	2.4	11.8	2.4	11.7	2.5	11.6	2.7	11.3	3.0	11.0	3.4
CWP 04 HP	6	16.3	2.7	16.0	3.1	16.0	3.3	15.8	3.5	15.7	3.7	15.6	3.8	15.2	4.3	14.9	4.8
	7	16.9	2.7	16.5	3.2	16.5	3.4	16.2	3.5	16.2	3.7	16.0	3.9	15.7	4.3	15.3	4.9
	8	17.4	2.7	17.0	3.2	17.0	3.4	16.7	3.5	16.6	3.7	16.5	3.9	16.1	4.4	15.7	4.9
	9	18.0	2.8	17.5	3.2	17.5	3.4	17.1	3.5	17.1	3.8	16.9	3.9	16.5	4.4	16.1	4.9
CWP 05 HP	6	20.0	3.1	19.5	3.6	19.5	3.9	19.1	4.0	19.1	4.3	18.9	4.5	18.5	5.0	18.1	5.6
	7	20.5	3.1	20.0	3.7	20.0	3.9	19.6	4.1	19.6	4.3	19.4	4.5	19.0	5.1	18.6	5.7
	8	21.1	3.1	20.6	3.7	20.6	3.9	20.3	4.1	20.2	4.3	20.0	4.5	19.5	5.1	19.1	5.7
	9	21.5	3.2	21.1	3.7	21.1	4.0	20.8	4.1	20.7	4.4	20.5	4.6	20.0	5.1	19.5	5.8
CWP 06 HP	6	24.2	4.1	23.8	4.7	23.8	5.1	23.5	5.2	23.4	5.5	23.2	5.8	22.7	6.5	22.2	7.2
	7	25.0	4.1	24.4	4.8	24.5	5.1	24.1	5.3	24.0	5.6	23.8	5.8	23.3	6.5	22.8	7.3
	8	25.7	4.1	25.2	4.8	25.2	5.1	24.8	5.3	24.7	5.6	24.5	5.9	23.9	6.6	23.4	7.3
	9	26.4	4.1	25.9	4.8	25.9	5.2	25.5	5.3	25.4	5.6	25.1	5.9	24.5	6.6	23.9	7.4
CWP 07 HP	6	34.3	5.7	33.8	6.7	33.8	7.1	33.3	7.4	33.3	7.8	33.0	8.2	32.3	9.2	31.8	10.2
	7	35.5	5.7	34.7	6.7	34.8	7.2	34.2	7.4	34.1	7.9	33.9	8.2	33.2	9.2	32.6	10.3
	8	36.5	5.7	35.7	6.7	35.8	7.2	35.2	7.5	35.1	7.9	34.8	8.3	34.1	9.3	33.5	10.4
	9	37.5	5.8	36.7	6.8	36.8	7.2	36.2	7.5	36.1	8.0	35.8	8.3	35.0	9.3	34.4	10.5
CWP 09 HP	6	41.5	7.0	40.8	8.2	40.9	8.7	40.3	9.0	40.3	9.5	39.9	9.9	39.0	11.1	38.3	12.4
	7	42.7	7.1	41.9	8.2	42.0	8.8	41.4	9.1	41.3	9.6	40.9	10.0	40.1	11.2	39.2	12.5
	8	44.1	7.1	43.2	8.3	43.3	8.8	42.6	9.2	42.5	9.7	42.1	10.1	41.2	11.3	40.3	12.6
	9	45.5	7.2	44.5	8.4	44.6	8.9	43.8	9.3	43.7	9.8	43.3	10.2	42.3	11.4	41.4	12.7
CWP 15 HP	6	50.4	8.7	49.6	10.2	49.7	10.8	49.0	11.2	49.0	11.8	48.6	12.3	47.8	13.8	47.0	15.4
	7	51.7	8.8	50.9	10.3	51.0	10.9	50.4	11.3	50.3	11.9	49.9	12.4	49.1	13.9	48.2	15.5
	8	53.2	8.8	52.3	10.2	52.4	10.9	51.7	11.3	51.6	11.9	51.2	12.5	50.3	13.9	49.3	15.6
	9	54.7	8.9	53.7	10.3	53.8	11.0	53.0	11.3	52.9	12.0	52.5	12.5	51.5	14.0	50.5	15.7
CWP 18 HP	6	79.5	14.3	74.0	15.5	72.4	15.7	70.8	15.9	69.3	16.2	67.8	16.5	64.0	17.1	60.0	17.7
	7	82.5	14.4	77.0	15.7	75.3	15.8	73.7	16.1	72.2	16.4	70.6	16.7	66.7	17.4	62.6	18.0
	8	85.6	14.6	79.9	15.8	78.1	16.0	76.5	16.3	74.9	16.7	73.3	17.0	69.4	17.7	65.2	18.4
	9	88.6	14.7	82.8	16.0	81.0	16.2	79.4	16.6	77.8	16.9	76.2	17.3	72.1	18.1	67.7	18.7
CWP 21 HP	6	89.7	17.8	83.9	19.3	82.2	19.7	80.6	20.1	79.0	20.5	77.4	20.9	73.3	21.6	69.2	22.3
	7	92.9	18.0	87.1	19.6	85.4	20.0	83.7	20.4	82.0	20.8	80.4	21.1	76.1	22.0	71.9	22.8
	8	96.2	18.2	90.3	19.8	88.5	20.3	86.8	20.7	85.0	21.1	83.3	21.4	79.0	22.4	74.6	23.2
	9	99.6	18.4	93.4	20.1	91.5	20.5	89.9	21.0	88.1	21.3	86.3	21.8	81.8	22.8	77.4	23.7
CWP 25 HP	6	133.9	23.1	122.2	25.3	118.9	25.7	115.6	26.2	112.3	26.8	109.2	27.1	101.4	28.2	94.0	29.0
	7	139.4	23.3	127.6	25.6	124.2	26.1	120.9	26.7	117.5	27.1	114.2	27.6	106.3	28.6	98.4	29.5
	8	145.0	23.6	133.1	26.0	129.7	26.5	126.2	27.1	122.8	27.6	119.3	28.0	111.0	29.2	102.9	30.2
	9	150.7	23.8	138.6	26.3	135.0	26.9	131.4	27.5	127.9	28.0	124.4	28.5	115.8	29.8	107.3	30.8
CWP 30 HP	6	159.3	28.6	148.3	31.0	144.9	31.3	142.0	31.9	139.0	32.5	135.9	33.0	128.2	34.4	120.3	35.4
	7	165.2	28.9	154.2	31.3	150.8	31.7	147.7	32.3	144.6	33.0	141.5	33.6	133.7	34.9	125.4	36.1
	8	171.3	29.2	160.0	31.7	156.5	32.1	153.3	32.8	150.2	33.5	147.1	34.1	139.0	35.5	130.6	36.8
	9	177.6	29.4	165.9	32.1	162.4	32.5	159.1	33.3	155.9	34.0	152.6	34.6	144.3	36.1	135.7	37.5
CWP 35 HP	6	193.4	36.1	180.9	39.0	177.2	39.8	173.8	40.6	170.3	41.4	166.8	42.1	157.9	43.8	149.1	45.2
	7	200.3	36.5	187.6	39.5	184.0	40.4	180.3	41.2	176.7	42.0	173.2	42.8	164.1	44.5	154.9	46.1
	8	207.4	36.8	194.4	40.0	190.7	40.9	187.0	41.8	183.2	42.7	179.5	43.5	170.2	45.3	160.8	46.9
	9	214.6	37.2	201.3	40.5	197.4	41.5	193.6	42.4	189.7	43.3	185.9	44.0	176.4	46.0	166.7	47.8
	10	222.1	37.5	208.1	41.0	204.2	42.0	200.2	43.0	196.3	43.9	192.3	44.7	182.5	46.8	172.7	48.7

Performance Data - CWP-RC with HFC 407C

Unit size	Leav. chilled water temp. (°C)	CONDENSING TEMPERATURE															
		36 °C		43 °C		45 °C		47 °C		49 °C		51 °C		56 °C		61 °C	
		Cool. capa. kW	Power input kW	Cool. capa. kW	Power input kW	Cool. capa. kW	Power input kW	Cool. capa. kW	Power input kW	Cool. capa. kW	Power input kW	Cool. capa. kW	Power input kW	Cool. capa. kW	Power input kW	Cool. capa. kW	Power input kW
CWP 02 RC	6	8.2	1.6	7.2	2.1	6.9	2.1	6.7	2.3	6.3	2.4	6.1	2.5	5.5	2.9	4.8	3.2
	7	8.0	1.8	7.5	2.1	7.4	2.1	7.0	2.3	6.6	2.4	6.4	2.6	5.8	2.9	4.5	3.2
	8	8.4	1.9	7.8	2.1	7.6	2.1	7.3	2.3	7.0	2.5	6.7	2.6	6.0	2.9	5.1	3.4
	9	9.2	2.0	8.2	2.1	7.9	2.2	7.6	2.3	7.3	2.5	7.0	2.6	6.3	3.0	5.4	3.4
CWP 03 RC	10	8.8	2.0	8.5	2.1	8.4	2.2	8.0	2.3	7.6	2.5	7.3	2.6	6.6	3.0	5.1	3.4
	6	9.3	2.2	8.7	2.4	8.5	2.4	8.1	2.6	7.7	2.8	7.4	2.9	6.7	3.3	5.2	3.9
	7	9.5	2.2	9.1	2.4	9.0	2.4	8.5	2.6	8.0	2.8	7.7	2.9	6.9	3.3	5.1	3.9
	8	10.6	2.3	9.5	2.4	9.2	2.5	8.8	2.7	8.4	2.8	8.1	3.0	7.3	3.3	6.1	4.0
CWP 04 RC	9	10.0	2.2	9.9	2.4	9.9	2.5	9.3	2.7	8.7	2.9	8.4	3.0	7.6	3.4	5.2	3.9
	10	10.5	2.6	10.3	2.5	10.2	2.4	9.7	2.7	9.2	3.0	8.8	3.1	7.9	3.4	5.9	4.8
	6	13.8	3.3	12.7	3.5	12.4	3.6	11.8	3.8	11.2	4.1	10.8	4.2	9.8	4.7	7.6	5.5
	7	14.1	3.3	13.3	3.6	13.1	3.6	12.4	3.9	11.7	4.1	11.3	4.3	10.2	4.8	7.8	5.5
CWP 05 RC	8	14.6	3.4	13.8	3.6	13.6	3.7	12.9	3.9	12.2	4.2	11.8	4.4	10.7	4.8	8.3	5.7
	9	14.9	3.5	14.4	3.7	14.3	3.7	13.5	4.0	12.7	4.2	12.3	4.4	11.2	4.9	8.2	5.7
	10	15.6	3.4	15.0	3.7	14.8	3.8	14.1	4.0	13.4	4.3	12.9	4.5	11.7	5.0	9.1	5.7
	6	16.9	3.7	15.6	4.1	15.2	4.2	14.5	4.5	13.8	4.7	13.3	4.9	12.1	5.5	9.5	6.3
CWP 06 RC	7	17.7	3.9	16.2	4.1	15.8	4.2	15.1	4.5	14.4	4.8	13.9	5.0	12.6	5.6	10.3	6.5
	8	18.0	3.9	16.9	4.2	16.6	4.3	15.8	4.6	15.0	4.8	14.5	5.1	13.2	5.6	10.3	6.5
	9	18.8	3.9	17.7	4.2	17.4	4.3	16.5	4.6	15.6	4.9	15.1	5.1	13.8	5.7	10.3	6.7
	10	18.7	3.9	18.3	4.3	18.2	4.4	17.2	4.7	16.2	5.0	15.7	5.2	14.4	5.8	10.3	6.8
CWP 07 RC	6	19.9	4.9	18.8	5.3	18.5	5.4	17.5	5.8	16.5	6.1	16.0	6.4	14.7	7.1	10.6	8.1
	7	21.0	5.0	19.6	5.4	19.2	5.5	18.3	5.8	17.4	6.2	16.8	6.4	15.3	7.1	12.0	8.3
	8	21.6	5.1	20.4	5.4	20.1	5.5	19.1	5.9	18.1	6.3	17.5	6.5	15.9	7.2	12.4	8.5
	9	23.1	5.2	21.3	5.5	20.8	5.6	19.9	6.0	19.0	6.3	18.3	6.6	16.5	7.3	13.7	8.6
CWP 08 RC	10	22.7	5.1	22.1	5.5	21.9	5.7	20.8	6.0	19.7	6.4	19.0	6.7	17.3	7.4	13.0	8.6
	6	27.8	6.9	26.7	7.5	26.4	7.6	25.0	8.1	23.6	8.6	22.9	9.0	21.1	10.0	15.3	11.5
	7	29.3	7.0	27.9	7.6	27.5	7.7	26.1	8.2	24.7	8.7	23.9	9.1	21.9	10.1	16.3	11.8
	8	31.0	7.1	29.1	7.7	28.6	7.8	27.2	8.3	25.8	8.8	25.0	9.2	22.9	10.2	17.7	11.9
CWP 09 RC	9	32.4	7.2	30.4	7.7	29.8	7.9	28.4	8.4	27.0	8.9	26.1	9.3	23.9	10.4	18.5	12.1
	10	33.3	7.2	31.5	7.8	31.0	8.0	29.6	8.5	28.2	9.0	27.3	9.5	25.0	10.5	19.9	12.2
	6	34.0	8.6	32.2	9.1	31.7	9.3	30.1	9.9	28.5	10.5	27.6	10.9	25.3	12.1	19.0	14.0
	7	35.7	8.7	33.6	9.3	33.0	9.4	31.4	10.0	29.8	10.6	28.8	11.1	26.3	12.2	20.2	14.4
CWP 10 RC	8	37.8	8.8	35.2	9.4	34.5	9.5	32.8	10.2	31.1	10.8	30.1	11.2	27.5	12.4	21.2	14.5
	9	39.2	9.0	36.7	9.5	36.0	9.7	34.3	10.3	32.6	10.9	31.5	11.4	28.7	12.6	22.5	14.8
	10	40.1	9.0	38.1	9.6	37.5	9.8	35.8	10.4	34.1	11.1	32.9	11.6	30.0	12.7	23.6	15.0
	6	41.2	10.4	39.0	11.3	38.4	11.6	36.6	12.3	34.8	13.0	33.7	13.6	30.9	15.0	24.1	17.5
CWP 15 RC	7	43.6	10.8	40.8	11.5	40.0	11.7	38.2	12.4	36.4	13.1	35.2	13.7	32.2	15.2	25.6	17.3
	8	44.6	11.4	42.4	11.6	41.8	11.7	39.8	12.5	37.8	13.3	36.6	13.9	33.5	15.3	26.1	18.4
	9	47.4	10.7	44.2	11.7	43.3	12.0	41.4	12.7	39.5	13.4	38.2	14.0	34.9	15.5	28.2	17.6
	10	47.8	11.1	45.8	11.8	45.2	12.0	43.2	12.8	41.2	13.6	39.8	14.2	36.4	15.7	28.9	18.4
CWP 18 RC	6	61.5	12.7	55.0	13.7	53.3	13.9	51.5	14.2	49.7	14.4	47.9	14.7	43.7	15.2	39.3	15.7
	7	64.3	12.8	57.7	13.9	55.8	14.1	54.0	14.3	52.1	14.6	50.4	14.9	45.9	15.5	41.3	16.0
	8	67.1	13.0	60.3	14.1	58.4	14.3	56.5	14.5	54.6	14.9	52.8	15.1	48.2	15.7	43.4	16.3
	9	69.9	13.1	62.9	14.3	60.9	14.4	59.0	14.8	57.0	15.0	55.2	15.4	50.4	16.1	45.6	16.6
CWP 21 RC	10	72.8	13.2	65.5	14.4	63.5	14.6	61.5	15.0	59.5	15.3	57.6	15.6	52.6	16.3	47.6	16.9
	6	74.2	16.0	66.8	17.3	64.6	17.7	62.6	18.0	60.4	18.4	58.4	18.7	53.2	19.5	48.2	20.1
	7	77.4	16.2	69.7	17.6	67.6	18.0	65.4	18.3	63.3	18.7	61.1	19.0	55.8	19.8	50.7	20.5
	8	80.6	16.4	72.7	17.8	70.5	18.2	68.3	18.6	66.0	18.9	63.8	19.3	58.4	20.2	53.0	20.9
CWP 25 RC	9	83.9	16.5	75.8	18.0	73.4	18.4	71.2	18.8	68.8	19.2	66.6	19.6	60.9	20.5	55.4	21.3
	10	87.3	16.6	78.8	18.2	76.4	18.7	74.0	19.1	71.6	19.5	69.3	19.9	63.5	20.9	57.7	21.7
	6	99.3	20.5	86.6	22.4	83.2	22.8	79.8	23.2	76.4	23.8	73.2	24.1	65.3	25.0	57.8	25.7
	7	103.9	20.7	91.2	22.7	87.7	23.1	84.2	23.7	80.7	24.1	77.3	24.5	69.0	25.4	61.2	26.2
CWP 30 RC	8	108.8	20.9	95.8	23.0	92.2	23.6	88.6	24.1	84.9	24.5	81.5	24.9	72.9	25.9	64.6	26.8
	9	113.8	21.1	100.5	23.3	96.7	23.9	93.0	24.4	89.2	24.9	85.6	25.3	76.7	26.4	68.1	27.3
	10	118.9	21.3	105.1	23.7	101.2	24.2	97.3	24.8	93.5	25.3	89.7	25.8	80.5	26.9	71.6	27.8
	6	123.5	25.5	110.4	27.6	106.8	28.0	103.2	28.5	99.7	29.0	96.2	29.4	87.5	30.6	78.6	31.6
CWP 35 RC	7	128.9	25.8	115.6	28.0	111.9	28.3	108.2	28.8	104.6	29.4	101.1	29.9	92.0	31.2	82.9	32.2
	8	134.5	26.0	120.8	28.3	117.0	28.6	113.2	29.3	109.6	29.9	105.9	30.4	96.5	31.7	87.1	32.8
	9	140.1	26.2	126.1	28.6	122.2	29.0	118.4	29.7	114.5	30.3	110.7	30.8	101.1	32.2	91.3	33.4
	10	145.9	26.5	131.4	28.9	127.3	29.4	123.4	30.0	119.4	30.7	115.5	31.3	105.7	32.7	95.6	33.9
CWP 40 RC	6	149.8	32.1	134.6	34.6	130.3	35.4	126.1	36.1	121.8	36.8	117.7	37.4	107.5	38.9	97.3	40.2
	7	156.1	32.4	140.7	35.1	136.2	35.9	131.9	36.6	127.5	37.3	123.3	38.0	112.6	39.6	102.1	41.0
	8	162.6	32.7	146.8	35.5	142.2	36.3	137.7	37.1	133.2	37.9	128.8	38.6	117.7	40.3	106.9	41.7
	9	169.3	33.1	152.9	36.0	148.1	36.9	143.5	37.6	138.8	38.4	134.3	39.2	122.9	40.9	111.7	42.5
10	176.1	33.3	159.0	36.4	154.1	37.3	149.3	38.2	144.5	39.0	139.7	39.8	128.1	41.6	116.6	43.3	

Water Pressure Drops

CWP-CO / CWP-HP / CWP-RC models		PRESSURE DROPS IN THE EVAPORATOR						
		02	03	04	05	06	07	09
K	$10^4 \text{ kPa}/(\text{m}^3/\text{s})^2$	13246.5	4657	4660	2464	2464.9	1477.7	1479.6
Min. water flow rate	l/s	0.3	0.3	0.5	0.6	0.7	1.0	1.2
Nominal water flow rate	l/s	0.4	0.4	0.6	0.8	0.9	1.3	1.6
Max. water flow rate	l/s	0.6	0.7	1.1	1.3	1.6	2.2	2.7
Min. pressure drops	kPa	8.9	4.6	9.6	7.6	11.1	13.5	19.6
Nominal pressure drops	kPa	17.0	9.0	18.8	15.0	21.8	26.4	38.4
Max. pressure drops	kPa	49.0	25.0	52.3	41.5	60.7	73.5	106.6

CWP-CO / CWP-HP / CWP-RC models		PRESSURE DROPS IN THE EVAPORATOR					
		15	18	21	25	30	35
K	$10^4 \text{ kPa}/(\text{m}^3/\text{s})^2$	1055.5	517.1	416.5	244.9	161.7	107.1
Min. water flow rate	l/s	1.4	1.9	2.3	3.0	3.8	4.6
Nominal water flow rate	l/s	1.9	2.7	3.2	4.2	5.3	6.5
Max. water flow rate	l/s	3.2	4.4	5.4	7.0	8.9	10.8
Min. pressure drops	kPa	20.4	18.8	22.2	21.9	23.6	23.1
Nominal pressure drops	kPa	39.9	37.0	43.0	43.0	46.0	45.0
Max. pressure drops	kPa	110.9	102.0	121.0	119.0	128.0	126.0

CWP-CO / CWP-HP models		PRESSURE DROPS IN THE CONDENSER						
		02	03	04	05	06	07	09
K	$10^4 \text{ kPa}/(\text{m}^3/\text{s})^2$	13356.1	13327.8	4667.6	4653	2462.4	2468.9	1480.2
Min. water flow rate	l/s	0.3	0.4	0.6	0.7	0.8	1.2	1.4
Nominal water flow rate	l/s	0.5	0.6	0.8	1.0	1.2	1.7	2.0
Max. water flow rate	l/s	0.8	0.9	1.3	1.6	2.0	2.8	3.4
Min. pressure drops	kPa	14.2	21.0	15.1	22.1	17.6	35.5	31.0
Nominal pressure drops	kPa	27.9	40.8	29.6	43.4	34.5	69.7	61.0
Max. pressure drops	kPa	77.6	113.3	82.0	121.0	96.0	194.0	169.2

CWP-CO / CWP-HP models		PRESSURE DROPS IN THE CONDENSER					
		15	18	21	25	30	35
K	$10^4 \text{ kPa}/(\text{m}^3/\text{s})^2$	1055.6	517.0	416.0	245.0	161.6	107.1
Min. water flow rate	l/s	1.8	2.4	2.9	3.8	4.8	5.9
Nominal water flow rate	l/s	2.5	3.3	4.1	5.3	6.7	8.2
Max. water flow rate	l/s	4.1	5.6	6.8	8.8	11.2	13.7
Min. pressure drops	kPa	32.8	29.4	35.4	35.0	37.0	36.9
Nominal pressure drops	kPa	64.2	57.7	69.5	68.7	72.5	72.4
Max. pressure drops	kPa	178.4	160.2	193.0	190.8	201.4	201.1

Dimensions - CWP-CO/CWP-HP 02 to 21

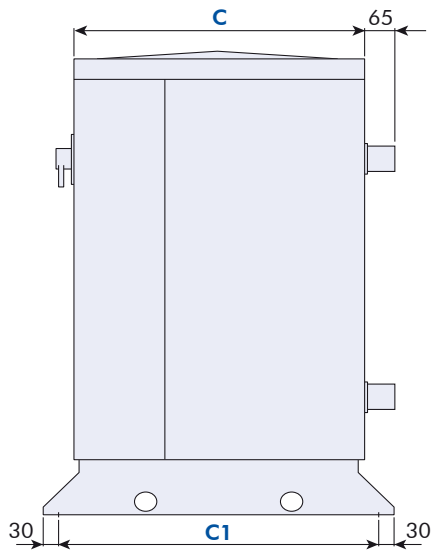

Side view

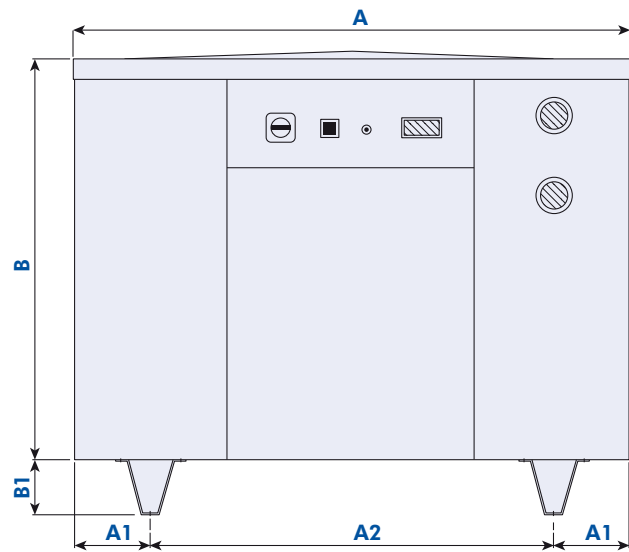

Front view

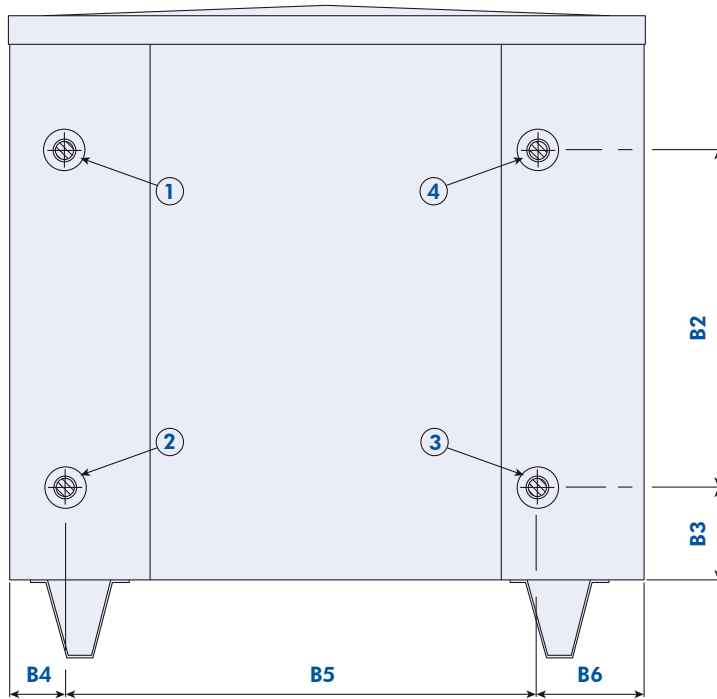

Rear view

- ① Evaporator inlet
- ② Evaporator outlet
- ③ Condenser inlet
- ④ Condenser outlet

Unit size	A	A1	A2	B	B1	B2	B3	B4	B5	B6	C	C1
02 to 05	800	75	650	900	110	478	135	80	567	153	480	540
06 to 09	900	100	700	900	110	478	135	80	667	153	580	640
15 to 21	1100	150	800	1000	110	518	145	100	800	200	730	790

Dimensions in mm.

Unit size	02	03	04	05	06	07	09	15	18	21
Evaporator inlet	1"1/4	1"1/4	1"1/4	1"1/4	1"1/4	1"1/4	1"1/4	1"1/4	1"1/4	1"1/4
Evaporator outlet	1"1/4	1"1/4	1"1/4	1"1/4	1"1/4	1"1/4	1"1/4	1"1/4	1"1/4	1"1/4
Condenser inlet	1"1/4	1"1/4	1"1/4	1"1/4	1"1/4	1"1/4	1"1/4	1"1/4	1"1/4	1"1/4
Condenser outlet	1"1/4	1"1/4	1"1/4	1"1/4	1"1/4	1"1/4	1"1/4	1"1/4	1"1/4	1"1/4

Dimensions - CWP-RC 02 to 21

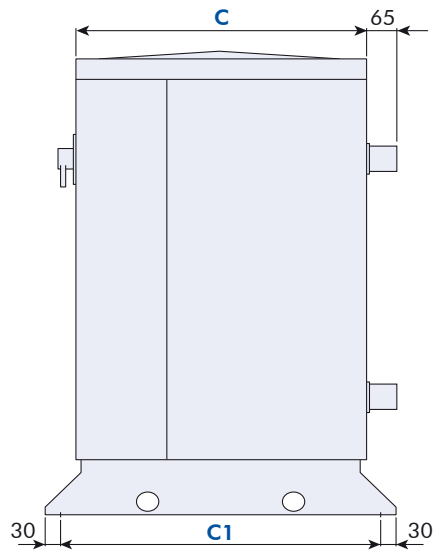

Side view

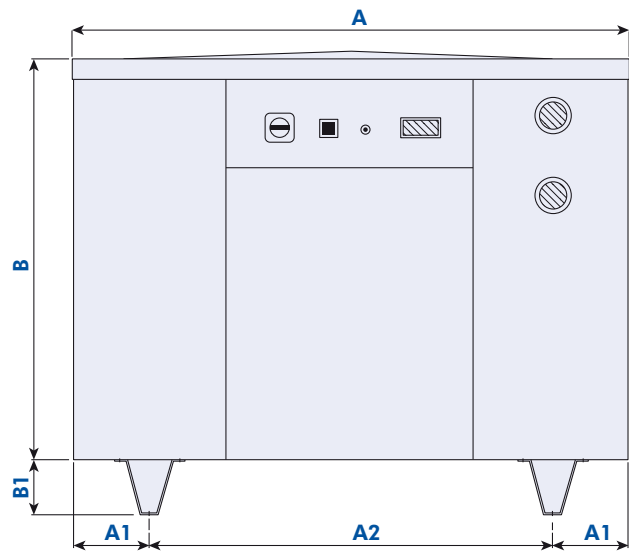

Front view

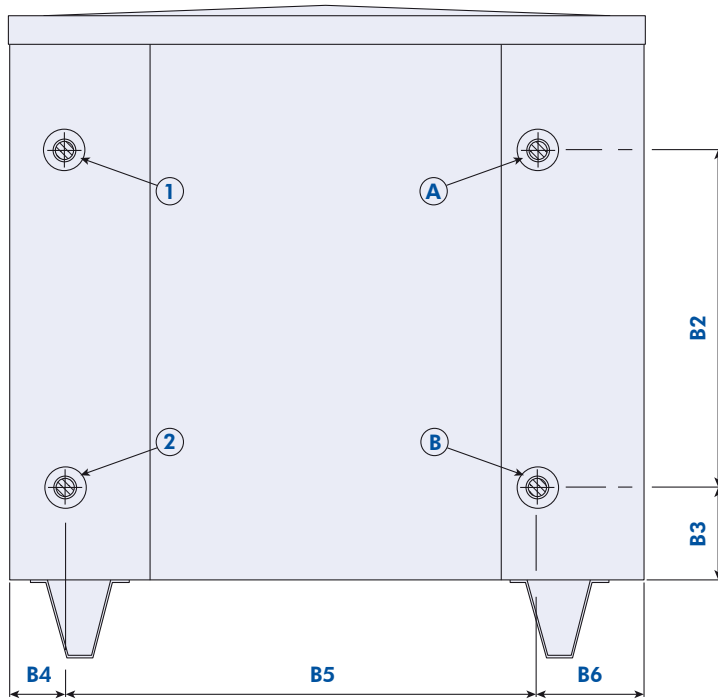

Rear view

- ① Evaporator inlet
- ② Evaporator outlet
- A Discharge line
- B Liquid line

Unit size	A	A1	A2	B	B1	B2	B3	B4	B5	B6	C	C1
02 to 05	800	75	650	900	110	478	135	80	567	153	480	540
06 to 09	900	100	700	900	110	478	135	80	667	153	580	640
15 to 21	1100	150	800	1000	110	518	145	100	800	200	730	790

Dimensions in mm.

Unit size	02	03	04	05	06	07	09	15	18	21
Evaporator inlet	1"1/4	1"1/4	1"1/4	1"1/4	1"1/4	1"1/4	1"1/4	1"1/4	1"1/4	1"1/4
Evaporator outlet	1"1/4	1"1/4	1"1/4	1"1/4	1"1/4	1"1/4	1"1/4	1"1/4	1"1/4	1"1/4
Discharge line	5/8"	5/8"	5/8"	5/8"	7/8"	7/8"	7/8"	1"1/8"	1"1/8"	1"1/8"
Liquid line	3/8"	1/2"	1/2"	1/2"	1/2"	5/8"	5/8"	5/8"	7/8"	7/8"

Dimensions - CWP-CO/CWP-HP 25 to 35

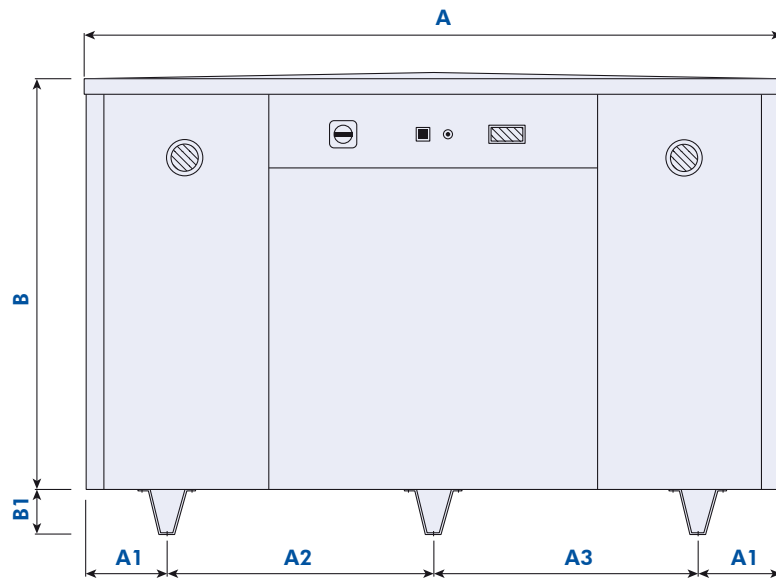

Front view

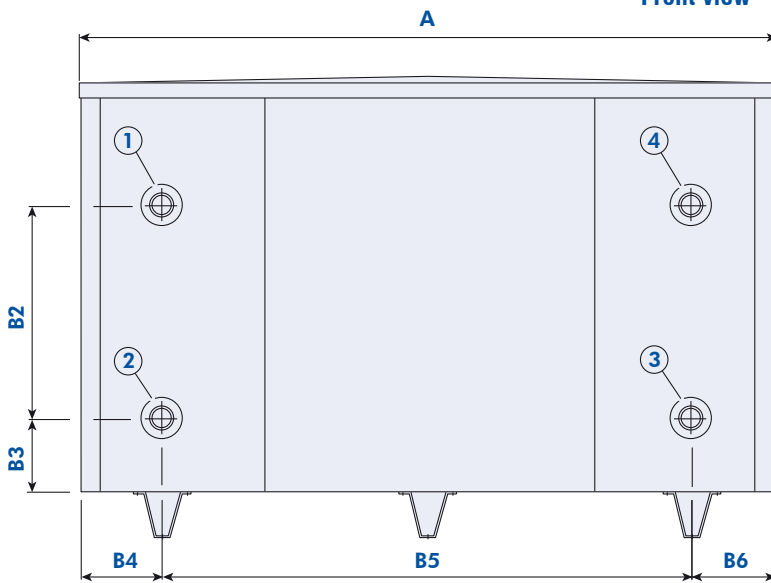

Rear view

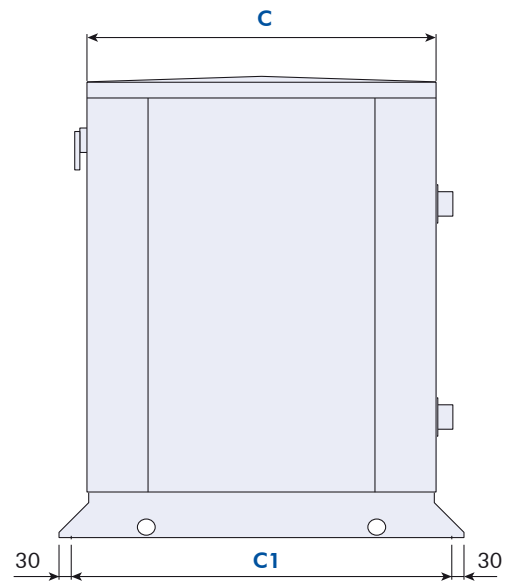

Side view

- ① Evaporator inlet
- ② Evaporator outlet
- ③ Condenser inlet
- ④ Condenser outlet

Unit size	A	A1	A2	A3	B	B1	B2	B3	B4	B5	B6	C	C1
25 to 35	1700	200	650	650	1100	110	518	145	206	1288	206	850	924

Dimensions in mm.

Unit size	25	30	35
Evaporator inlet	2"	2"	2"
Evaporator outlet	2"	2"	2"
Condenser inlet	2"	2"	2"
Condenser outlet	2"	2"	2"

Dimensions - CWP-RC 25 to 35

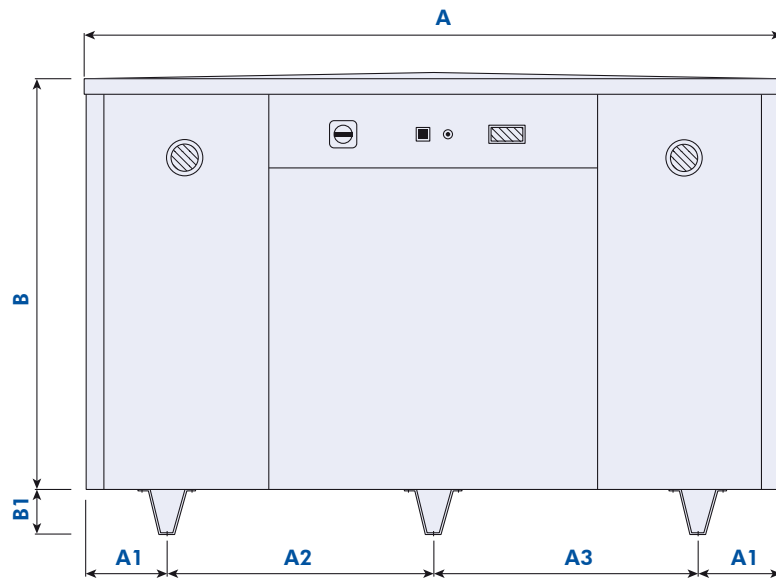

Front view

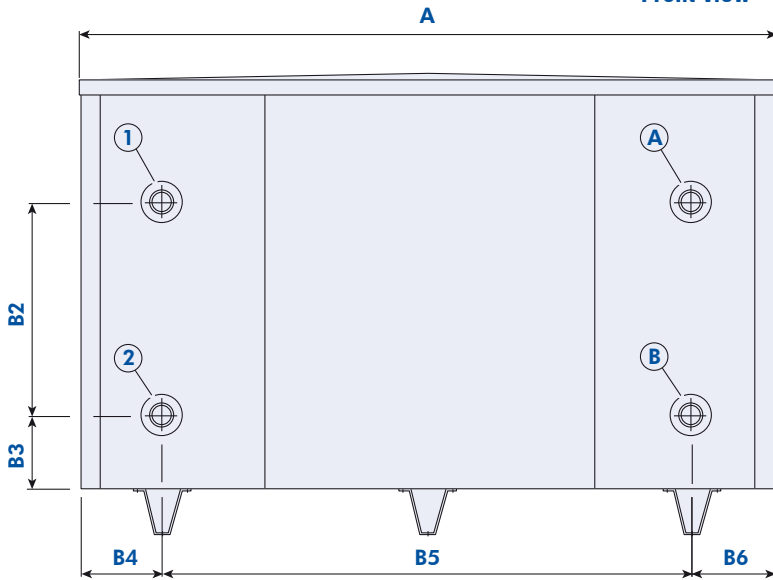

Rear view

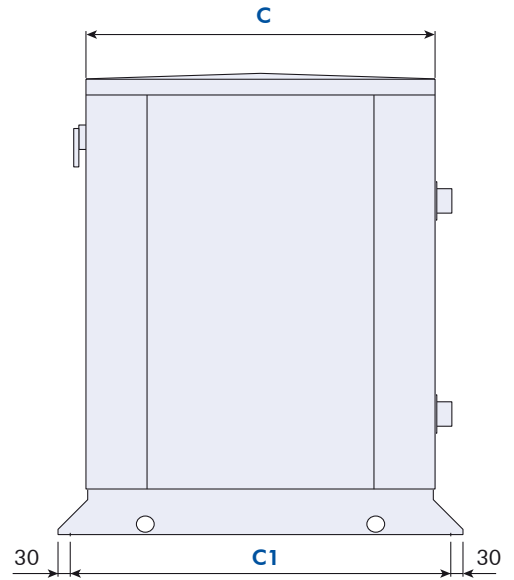

Side view

- ① Evaporator inlet
- ② Evaporator outlet
- Ⓐ Discharge line
- Ⓑ Liquid line

Unit size	A	A1	A2	A3	B	B1	B2	B3	B4	B5	B6	C	C1
25 to 35	1700	200	650	650	1100	110	518	145	206	1288	206	850	924

Dimensions in mm.

Unit size	25	30	35
Evaporator inlet	2"	2"	2"
Evaporator outlet	2"	2"	2"
Discharge line	1 ³ / ₈	1 ⁵ / ₈	1 ⁵ / ₈
Liquid line	7/ ₈ "	1 ¹ / ₈	1 ¹ / ₈

Minimum Installation Clearances

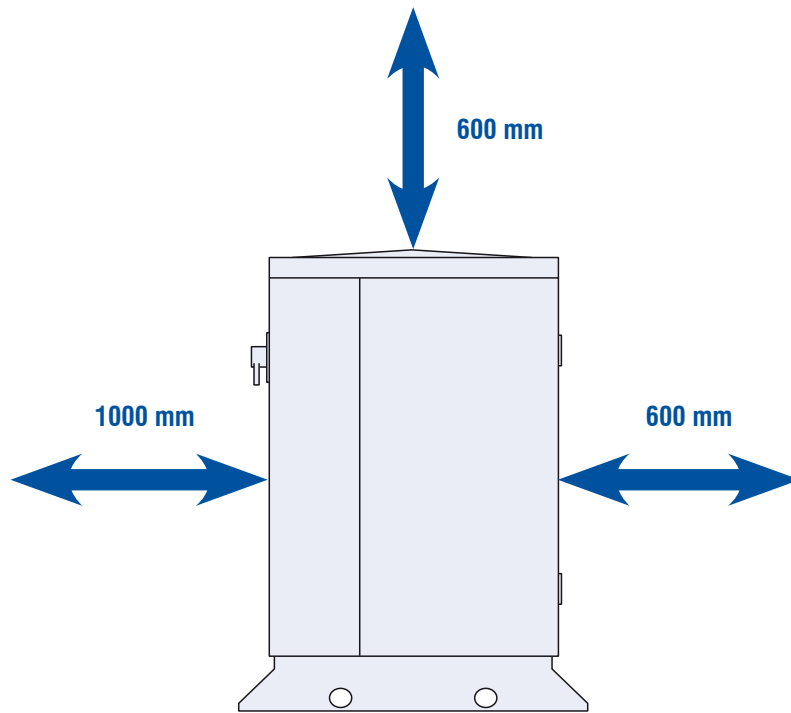

Side view

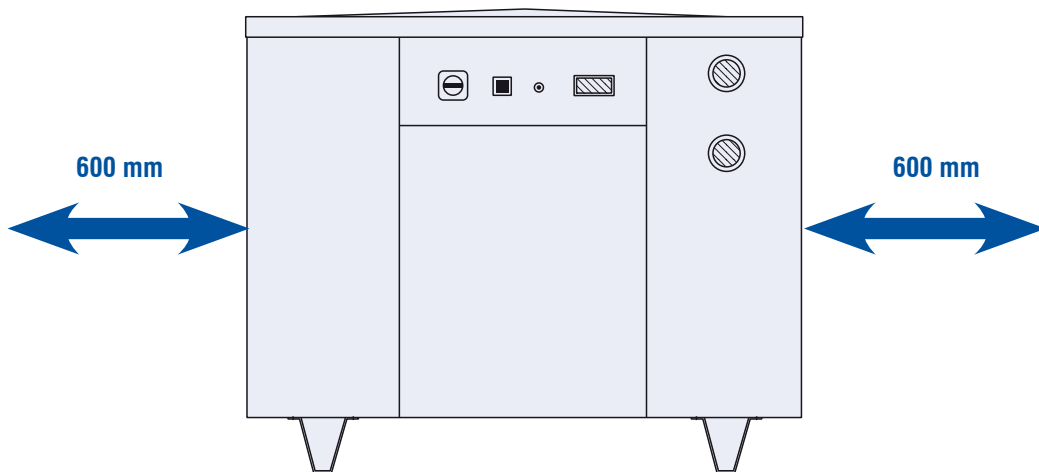

Front view



AIRWELL France SAS
1 bis, Avenue du 8 mai 1945
Saint Quentin en Yvelines
78284 GUYANCOURT
France
Tel. +33 (0) 01 39 44 78 00
Fax +33 (0) 01 39 44 65 17

Ref. : EDM CWP-A.6GB/07.09 - Supersedes : EDM CWP-A.5GB/10.08

As part of our ongoing product improvement programme, our products are subject to change without prior notice. Non contractual photos.