

AQCH

Air-to-Water Reverse Cycle Heat Pumps
with centrifugal fans

Models 25 to 80



25 to 76 kW



27 to 84 kW



Aqu@Logic Centrifugal Fan Air-to-Water Heat Pumps

The new range of **AQCH** air-to-water reverse cycle heat pumps **with centrifugal fans** is composed of **8 models** covering a nominal cooling capacity range from 25 to 76 kW and a nominal heating capacity range from 27 to 84 kW.

AQCH represents a new generation of innovative heat pumps, integrating components using the very latest technological advances.

These components provide **AQCH** heat pumps with considerable advantages in terms of compact design and improved efficiency and reliability.

All **AQCH** heat pumps are equipped with **ILTC (Intelligent Liquid Technology Chiller)** control providing optimised control across the unit's entire operating range.

As standard equipment, each unit has two compressors, fitted in tandem, for adapting to partial system loads.

Pressure and temperature sensors provide data to the electronic control system for taking account of the prevailing operating parameters in order to optimise system performance.

This intelligent control system enables water temperature to be maintained within the required range, whilst only using a small volume of water (**2.5 l/kW**) and thus eliminating, for the majority of comfort air conditioning applications, the need for a buffer water tank.

Features and Benefits

A maximum of technology

The new generation of **AQCH** air-to-water reverse cycle heat pumps integrates high technology components :

- Scroll compressors.
- Brazed stainless steel plate heat exchangers.
- Microprocessor based **ILTC control**.
- HFC 407C refrigerant.

Quick and easy installation at minimal cost

- Compact units taking up the strict minimum of ground surface area, for easy installation.
- "Plug and Play" design with an integrated hydraulic module for minimising installation costs.
- Perfect accessibility : easy access to all components, thanks to panels removable by screws, thus significantly reducing unit maintenance times.

Increased performance

- Optimal efficiency, thanks to the use of Scroll compressors with a high Coefficient Of Performance (COP), fitted in tandem on all models in the range.

Built to last

- **ILTC control** automatically manages the balancing of the compressors' running times, thus enabling their service life to be extended.
- Sealed refrigerant circuit : all the refrigerant components and pipe work are brazed, thus eliminating any risks of leakage. Pressure transducers replace the HP and LP pressostats, along with their capillary tubes (principal source of leaks).

Energy savings all year round

Thanks to **ILTC control** :

- Providing intelligent management of the compressors' running times.
- In the majority of cases, obviating the need for a buffer tank for comfort air conditioning applications (2.5 l/kW).
- Continuously monitoring and managing all the machine's operating parameters.

Optimized defrost

The management of the defrost cycles is assured by the ILTC control, which decides in relation to the unit operating parameters and through temperature and pressure sensors, the start and the stop of the unit defrost.

Specifications

Cabinet and structure

- Made of galvanised steel panels coated with oven-baked epoxy paint. Colour : RAL 9001.
- For access to all components, the panels are removable by just removing the fixing screws.

Compressors

- Hermetically sealed, high output Scroll type compressors with a high Coefficient Of Performance (COP).
- All models in the range equipped with compressors fitted in tandem for reducing both starting current draw and power absorbed under partial load conditions.

- Excellent acoustic performance with extremely quiet operation and minimal vibration.
- Robust and reliable Scroll compressor technology :
Few moving parts (only 3), high tolerance to liquid pressure shocks, low starting torque, protection against excessive discharge temperatures.
- Compressor motor cooled by intake gasses and equipped with automatic reset internal high temperature protection.
- All compressors are mounted on anti-vibration pads in order to minimise noise and vibration transmission.

Specifications (continued)

Evaporator

- Direct expansion type, made of brazed stainless steel plates.
- The evaporator is surrounded by an electrical heating resistance and insulated with cellular polyurethane foam to provide anti-freeze protection.

Air cooled condenser coils

Condenser coil consists of seamless copper tubes arranged in staggered row pattern.

The coil is mechanically expanded into aluminium fins with full fin collars.

Fins are supplied, as standard, with hydrophilic coating (blue fins).

Condensate drain pan, with two outlet pipes on both ends, is supplied underneath the condenser coil.

Condenser fans and motor

Fans are of belt driven centrifugal type capable of providing external static pressures (standard and high pressures) to overcome the ductwork air resistance.

Variable pitch pulley is supplied as standard to allow air flow to be adjusted.

Electrical motor is of IP55 type and mounted on sliding plate allowing belt tension adjustment to be performed, by way of a single screw, without having to slacken the motor mounting.

Motor is protected by a circuit breaker. **Optional high static motor** can be supplied for high external static pressure applications.

Fan discharge arrangement

The fan discharge of each unit can be configured in 3 different arrangements compared with horizontal return air :

- **Standard horizontal discharge** (same side as return),
- **Optional vertical discharge**,
- **Optional opposite horizontal discharge**.

At the discharge side, a duct collar is supplied as standard.

Refrigerant circuit

The refrigerant circuit comprises all the required components such as filter-dryer, sight glass with moisture indicator, 4-way reverse cycle valve and thermostatic expansion valve. It also comprises high and low pressure sensors, as well as sensors for inlet and outlet water temperatures and a discharge temperature sensor.

To facilitate maintenance operations, the low and high pressure sections of the refrigerant circuit are equipped with pressure tapping points.

All the refrigerant components and pipe work are brazed, thus eliminating any risks of leakage and ensuring total, long lasting circuit tightness.

Pressure transducers replace the HP (High Pressure) and LP (Low Pressure) pressostats, along with their capillary tubes (principal source of leaks).

The refrigerant circuit is optimised to operate with HFC 407C refrigerant.

Electrical panel

Access to the electrical panel is possible after having taken off the panel, removable by just releasing the fixing screws.

The following equipment is mounted on the power circuit side of the electrical panel : a power supply connection terminal block - 400 V / 3 Ph / 50 Hz + Neutral, a main switch, a phase controller (allowing the presence and the order of the phases to be detected), contactors and magnetothermal circuit breakers for the compressors, fans and hydraulic pump (if fitted). On the control circuit side of the panel, the ILTC control electronic circuit board with its 230 V single phase power supply is mounted.

Integrated hydraulic module

An integrated hydraulic module is available for all AQCH units, offering savings in installation times and reducing installation costs. Each hydraulic module comprises the following components :

On models 25 to 35 : Automatic air bleed valve, differential pressostat, drain cock, expansion tank, safety valve, pressure gauge, hydraulic pump and water filter (supplied loose).

On models 40 to 80 : Automatic air bleed valve, water flow adjustment valve, water flow switch, drain cock, expansion tank, safety valve, pressure gauge, hydraulic pump and water filter (supplied fitted).

As standard, all pumps produce available pressure higher than 100 kPa.

Other standard equipment

Water flow switch or differential pressostat : For AQCH units without an integrated hydraulic module, a factory-fitted differential pressostat (for models 25 to 35) and a factory-installed paddle type water flow switch (for models 40 to 80) are supplied as standard.

Water filter : Supplied loose on units without integrated hydraulic module.

Accessories and options

- **Anti-vibration pads** : Rubber anti-vibration pads, to be fitted on site by the installer.
- **Anti-vibration mounts** : Visible spring anti-vibration mounts, for on site fitting by the installer.
- **Compressor jacket** : Supplied fitted.
- **Condenser coil protective coating** :
 - aluminium fins with polyurethane coating.
- **High static motor**.
- **Remote control terminal** : Hard-wired control enabling the unit's Start / Stop functions to be controlled remotely.
- **Low ambient kit (-7 °C)** : For cooling mode operation only, factory-fitted option consists of frequency inverter acting on the motor in order to keep fan speed under control.
- **Chiller sequencer** : Supplied loose, it allows a control up to 4 units.
- **Water isolating valves** : Supplied loose.
- **Water flow switch** : Factory-installed option for models 25 to 35.
- **Double water pump** : Supplied with a control and power supply remote panel. The electrical supply of the latter is to be carried out by others during installation.
- **Inlet air duct collar**.

ILTC Control System



The ILTC control system is an intelligent digital control system designed especially for optimising the operation of **AQCH** units and maintaining conditions of maximum comfort.

Before each start-up, the ILTC control system runs through a complete machine checklist. It continuously monitors and manages all the machine's operating parameters and safety devices. It precisely manages the running of the compressors and fans in order to optimise energy consumption. It also controls the operation of the water circulation pump.

User interface :

The ILTC control system has an easy-to-use user interface comprising a 4 character, 7 segment red colour LED display, 2 keys below the display for access to the different menus : the right key is reserved for scrolling up and down the menus, and the left key for selecting a parameter and displaying its value.

Six main menus are available for accessing all the machine's controls :

- Parameters.
- Temperature sensors and pressure transducers.
- Active safety alarms.
- Compressors' operating times.
- Safety alarms history (last 10 alarms).
- Machine operating status.

Using these 6 menus enables a machine status diagnosis to be performed as well as checking all the **AQCH** unit's parameter settings.

ILTC control system description

- Intelligent control with return water temperature control and outlet water temperature measurement.
- The selection and operating time duration of each compressor is automatically managed by the ILTC control system, with the possibility of balancing the compressors' operating times. When they are operating, the compressors are monitored constantly to improve their operating cycle and to avoid any excessive cycling. Thus, these **AQCH** units can operate in complete safety with a low volume of water in the installation, enabling the buffer tank to be dispensed with in the majority of comfort air conditioning applications.
- The ILTC control system is intelligent, i.e. it continuously adapts to changes in the installation's thermal load by optimising running times with the selection of one or both compressors, in relation to actual demand.
- Water pump control with 2 possible operating modes: Continuous operation in ON / OFF mode or operating only in ON mode.
- As standard, the ILTC control system offers the possibility of selecting a «Night-time running mode» function.

When the "**Night-time Running**" mode is activated, **4 operating modes** are available :

1st mode : Selected to change the set temperature for energy savings when the building is unoccupied.

2nd mode : Selected to enable the set temperature to be lowered.

3rd mode : Selected to change the set condensing pressure values.

4th mode : Selected for applying a combination of modes 1 and 3.

- In addition, as a standard feature, the ILTC control system offers the possibility of automatically compensating the set temperature value in relation to changes in the outdoor air temperature.
- Automatic switching of cooling or heating mode in relation to the two thresholds of external temperature configurable by the user.

Safety

The system measures changes in parameters (temperatures, pressures,...) and reacts to keep the compressor within its operating range.

If, despite everything, a parameter exceeds its limit, a warning message is generated and the machine is shut down.

The following faults cause the machine to shut down :

- Suction pressure too low.
- Discharge pressure too high.
- Outlet water temperature below authorised limits.
- Discharge temperature too high.
- Compressor(s), fan(s), water pump overload.
- Compressor direction of rotation reversed.
- Temperature sensors and pressure transducers fault.
- Evaporator anti-freeze protection.

The ILTC control system has **33 alarm codes** enabling the origin of breakdowns to be determined.

The following safety devices protect the units :

- Water flow switch or differential pressostat.
- Fan thermal relays.
- N° 1 and N° 2 compressor internal thermal protection.
- Hydraulic pump thermal relay.
- HP safety pressostat.

Remote unit management

The system enables the following functions to be operated, by means of dry contacts :

- Remote ON / OFF switch.
- Remote Day / Night running mode switch.
- Loadshedding mode.
- Remote alarm reading.
- Inversion of cooling or heating operating mode.

Refrigerant Flow Diagram

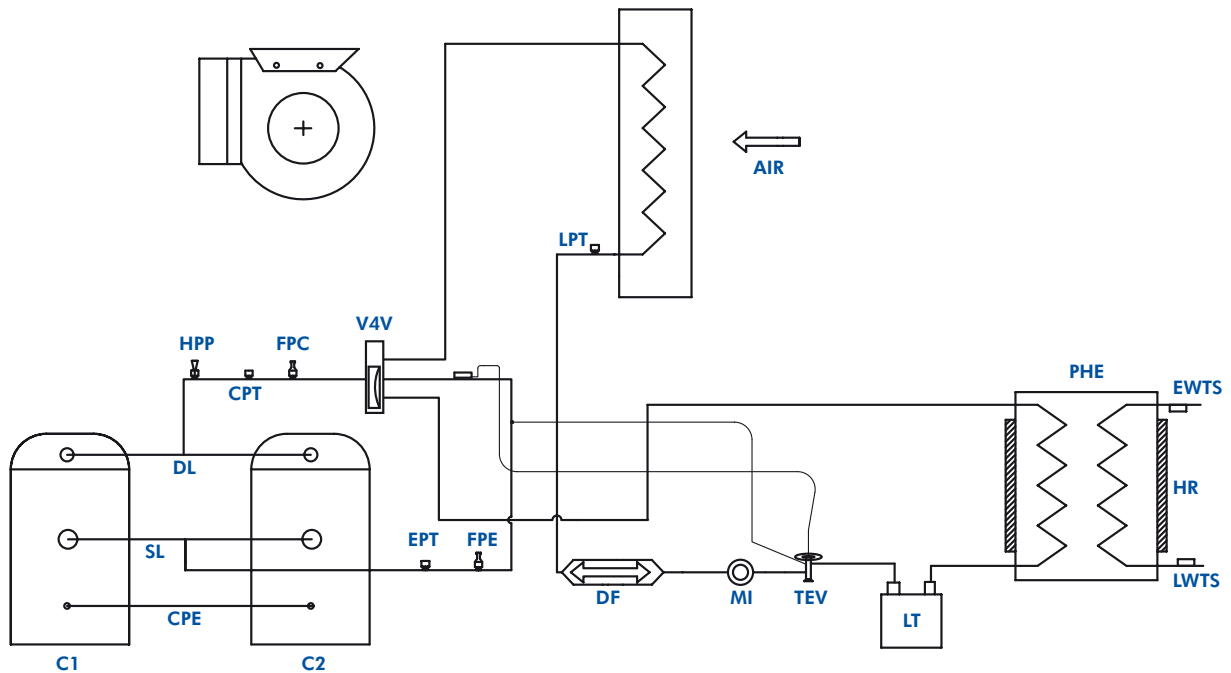

COMPONENTS			
C1	Compressor 1	HR	Evaporator safety heater
C2	Compressor 2	LPT	Liquid pressure tap
CPT	Condensing pressure tap	LT	Liquid receiver
DF	Filter drier	LWTS	Leaving water temperature sensor
DL	Discharge line	MI	Moisture indicator
EPT	Evaporator pressure tap	CPE	Oil level egalization
EWTS	Entering water temperature sensor	PHE	Plate heat exchanger
FPC	Condensation pressure transducer	SL	Suction line
FPE	Evaporator pressure transducer	TEV	Thermostatic expansion valve
HPP	High pressure switch	V4V	4-way valve

Protection devices

AQCH sizes	25	30	35	40	50	60	70	80
Fan thermal protection					Yes			
Compressors thermal protection						Yes		
Ancillaries / Fan circuit breakers						Yes		
Compressors circuit breakers		Yes						
Water pressure differential pressostat		Yes						
Water flow switch						Yes		
HP pressostat				Yes				
Evaporator anti-freeze protection				Yes				
HP transducer				Yes				
LP transducer				Yes				

Operating Limits

Operating temperature ranges - Cooling mode

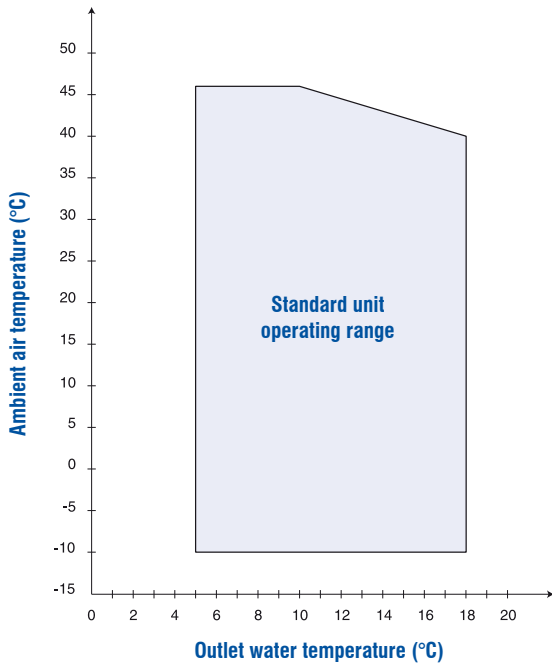

Operating temperature ranges - Heating mode

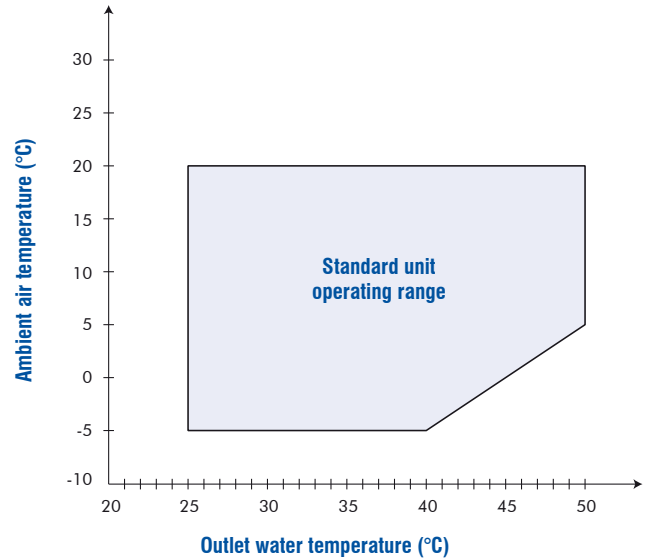

Operating limit data (*)

Temperature - Cooling mode		Min.	Max.
Inlet water at start-up	°C	10	30
Inlet water during running	°C	10	23
Outlet water during running (without glycol)	°C	5	18
Water temperature difference	K	3	7
Working pressure	bars	-	3
Air (standard unit)	°C	15	46
Air (unit with optional fan speed controller)	°C	-7	46

(*) For chilled water $\Delta T = 5$ K.

Temperature - Heating mode		Min.	Max.
Inlet water at start-up	°C	18	-
Inlet water during running	°C	20	45
Outlet water during running (without glycol)	°C	25	50
Water temperature difference	K	3	7
Working pressure	bars	-	3
Air	°C	-5	20

(*) For hot water $\Delta T = 5$ K.

Correction Factors

Altitude correction factors

Altitude (m)	Cooling capacity correction factors	Power consumption correction factors
0	1.000	1.000
600	0.987	1.010
1200	0.973	1.020
1800	0.958	1.029
2400	0.943	1.038

Evaporator fouling factors

Fouling factors (m ² ·°C/kW)	Cooling capacity correction factors	Power consumption correction factors
0.044	1.000	1.000
0.088	0.987	0.995
0.176	0.964	0.985
0.352	0.915	0.962

Condenser fouling factors

Fouling factors (m ² ·°C/kW)	Cooling capacity correction factors	Power consumption correction factors
0.044	1.000	1.000
0.088	0.987	1.023
0.176	0.955	1.068
0.352	0.910	1.135

Hydraulic Circuit Diagram

Basic version

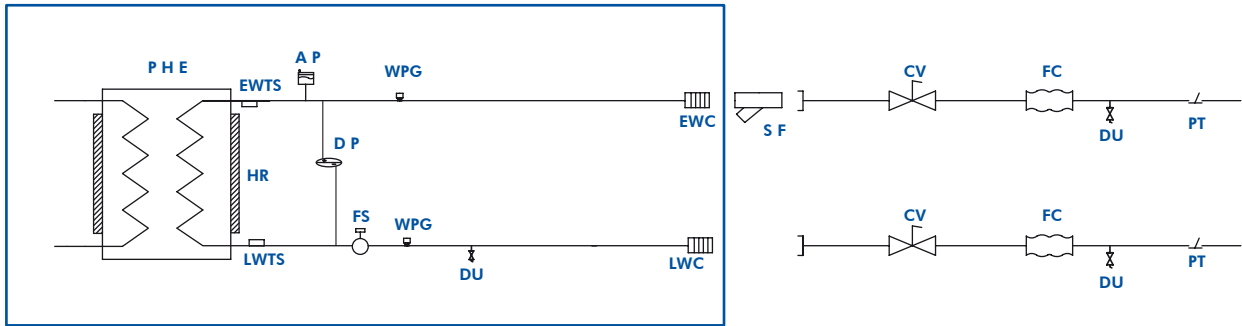

Pack version

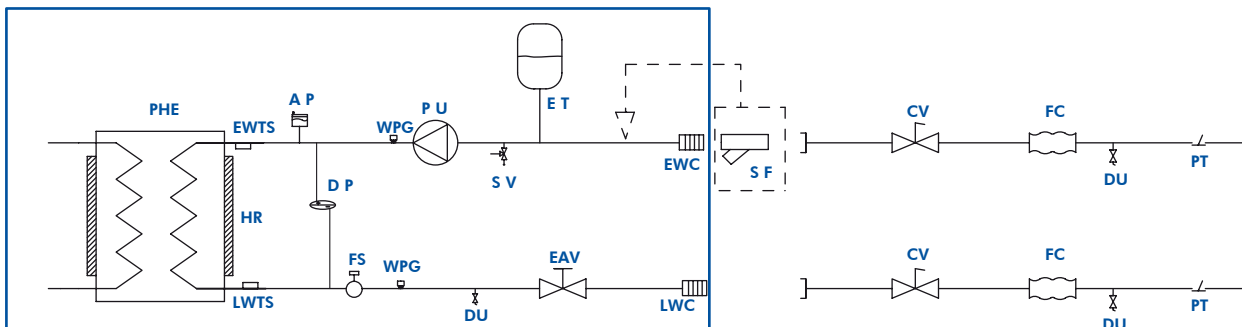

COMPONENTS

AP	Automatic air purge valve	HR	Evaporator safety heater
CV	Isolating valve	LWC	Leaving water connection
DP	Differential pressure switch (only on models 25/30/35)	LWTS	Leaving water temperature sensor
DU	Drain off valve	PHE	Plate heat exchanger
EAV	Manual adjustment valve	PT	Temperature sensor
ET	Expansion tank	PU	Water pump
EWC	Entering water connection	SF	Screen filter (supplied loose for models 25/30/35)
EWTS	Entering water temperature sensor	SV	Safety valve
FC	Flexible joint	WPG	Water pressure tap
FS	Flow switch (only on models 40 to 80)		

Hydraulic Circuit Water Volume

Minimum volume for comfort air conditioning applications

Sizes	25	30	35	40	50	60	70	80
Volume* (litres)	65	75	85	105	120	145	170	200

(*) Volumes calculated for Eurovent operating conditions (air : 35 °C, water 12/7 °C) with a 2.5 l/kW ratio. For other nominal operating conditions, recalculate the minimum volume by multiplying the corresponding cooling capacity by the 2.5l/kW ratio.

If the minimum volume requirement can not be met, an additional buffer tank must be included in the installation.

Maximum volume (*) in litres for comfort air conditioning applications

Sizes	25 to 35	40 to 80
Water	300	600
10% glycol solution	225	450
15% glycol solution	215	425
20% glycol solution	200	400
25% glycol solution	185	375
30% glycol solution	175	350
35% glycol solution	150	300

(*) Limit linked to the unit's expansion tank volume. In the case of an installation with a water volume greater than the values stated in the above table, an additional buffer tank must be included in the installation.

Physical Data

AQCH sizes		25	30	35	40	50	60	70	80
Power supply (V / Ph / Hz)		400/3+N/50							
Cooling capacity (1)	kW	24.9	28.8	33.7	39.6	46.2	56.3	67.5	76.5
Heating capacity (2)	kW	27.6	32.2	36.3	43.9	55.4	64.2	76.2	84.0
Total power consumption with pump (3)	kW	12.3	13.7	15.0	16.8	22.7	26.6	29.2	32.7
Total power consumption (3)	kW	11.5	12.9	14.2	16.1	22.0	25.5	28.1	31.6
Total power consumption with pump (4)	kW	12.3	13.7	14.3	17.0	22.8	26.9	29.2	32.7
Total power consumption (4)	kW	11.5	12.9	13.5	16.2	22.0	25.8	28.1	31.6
Refrigerant charge	kg	6.25	7.36	10.51	10.5	12.5	12.95	23	23
COMPRESSORS									
Type		Scroll							
Quantity		2	2	2	2	2	2	2	2
Capacity reduction stages		2	2	2	2	2	2	2	2
Minimum capacity	%	50	50	50	45	36	36	45	50
Safety pressostat		HP (fixed set point)							
		LP transducer							
		HP transducer							
EVAPORATOR									
Type		Brazed stainless steel plates							
Maximum pressure refrigerant side	bar	30							
Maximum pressure water side	bar	10							
Safety		Pressure differential switch				Water flow switch			
Anti-freeze protection heating resistance		1	1	1	1	1	1	1	1
Water volume	liters	2.2	2.44	2.44	3.44	4.33	5.33	6.33	7.10
CONDENSER									
Type		3/8" copper tube - smooth aluminium fins							
FANS									
Type		Centrifugal							
Number of fans		2	2	2	2	2	2	2	2
Nominal airflow (standard motor)	m³/h	13500	14000	14000	15000	19500	20000	26000	27000
External static pressure (standard motor)	Pa	130	130	130	130	130	130	200	200
Motor power (standard motor)	kW	3.0	3.0	3.0	4.0	5.5	5.5	7.5	7.5
Nominal airflow (high static option)	m³/h	13500	14000	14000	15000	19500	20000	26000	27000
External static pressure (high static option)	Pa	200	200	200	200	200	200	400	400
Motor power (high static option)	kW	4.0	4.0	4.0	5.5	7.5	7.5	11	11
WATER CONNECTIONS									
Type		Gas - Threaded				Gas - Threaded			
Diameter	inches	1" 1/2	1" 1/2	1" 1/2	2"	2"	2"	2"	2"
Expansion tank	liters	5				12			
Filter		1" 1/2, supplied loose				2", supplied loose			
Safety valve calibration	bar	3	3	3	3	3	3	3	3
Drain pan	inches	1"				1"			
WATER CIRCULATION PUMP									
Type		Single speed centrifugal pump							
Material		AISI 304 stainless steel				Composite			
Protection index		IP54				IP54			
Three phase motor		Class F				Class F			
WEIGHT									
With pump	kg	395	420	435	580	650	670	875	930
Without pump	kg	385	410	425	570	640	660	865	920
DIMENSIONS									
Length	mm	1752	1752	1752	2206	2206	2206	2464	2464
Width	mm	890	890	890	890	890	890	1100	1100
Height	mm	1505	1505	1505	1773	1773	1773	2313	2313

(1) Values are based on chilled water inlet/outlet temperature of 12/7 °C and an outdoor temperature of 35 °C.

(2) Values are based on hot water inlet/outlet temperature of 40/45 °C and an outdoor temperature of 7 °C.

(3) Cooling mode data.

(4) Heating mode data.

Electrical Data

Unit with standard fan motors

AQCH sizes	Fuse aM Type - (A)	Full load current (max.) 400V - (A)	Starting current (max.) - (A)
25	32	25	80
30	32	27	82
35	40	31	122
40	50	44	140
50	50	47	186
60	63	53	232
70	80	68.8	230
80	80	71	233

Unit with high static fan motors (optional)

AQCH sizes	Fuse aM Type - (A)	Full load current (max.) 400V - (A)	Starting current (max.) - (A)
25	32	27	82
30	32	29	92
35	40	33	124
40	63	47	142
50	63	51	188
60	63	56	236
70	80	71.8	233
80	80	74	236

Compressors

AQCH sizes		25	30	35	40	50	60	70	80
Nominal power consumption	KW	4.3 + 4.3	5.0 + 5.0	6.1 + 6.1	7.9 + 6.4	11.2 + 6.4	13.8 + 7.6	13.8 + 11.2	13.8 + 13.8
Maximum power consumption	KW	6 + 6	7 + 7	8 + 8	10 + 8	15 + 8	18 + 10	18 + 15	18 + 18
Nominal current	A	8.1 + 8.1	8.8 + 8.8	11.2 + 11.2	14.3 + 12.2	19.3 + 12.2	23.1 + 14.3	23.1 + 19.3	23.1 + 23.1
Maximum current	A	10 + 10	11.4 + 11.4	13.3 + 13.3	18 + 14.6	25.6 + 14.6	27.8 + 18	27.8 + 25.6	27.8 + 27.8
Crankcase heater	W	70 + 70	70 + 70	70 + 70	70 + 70	70 + 70	70 + 70	70 + 70	70 + 70

Standard fan motors

AQCH sizes		25	30	35	40	50	60	70	80
Supply voltage (V / Ph / Hz)		400 / 3 / 50							
Nominal power input	KW	3.0	3.0	3.0	4.0	5.5	5.5	7.5	7.5
Nominal current input	A	6.3	6.3	6.3	8.1	11.0	11.0	14.7	14.7

High static fan motors (optional)

AQCH sizes		25	30	35	40	50	60	70	80
Supply voltage (V / Ph / Hz)		400 / 3 / 50							
Nominal power input	KW	4.0	4.0	4.0	5.5	7.5	7.5	11	11
Nominal current input	A	8.1	8.1	8.1	11.0	14.7	14.7	21	21

Standard pumps

AQCH sizes		25	30	35	40	50	60	70	80
Supply voltage (V / Ph / Hz)		400 / 3 / 50							
Nominal power input	KW	0.55	0.55	0.55	0.75	0.75	1.1	1.1	1.1
Nominal current input	A	1.7	1.7	1.7	2.1	2.1	3.1	3.1	3.1

Evaporator heating resistance

AQCH sizes		25	30	35	40	50	60	70	80
Supply voltage (V / Ph / Hz)		230 / 1 / 50							
Maximum power input	W	35	35	35	35	35	35	35	35

Sound Data

In-duct sound power levels at discharge side Units with standard fan motors and completely closed pulley

Sizes	Frequencies (Hz)								Lw global dB(A)
	63	125	250	500	1000	2000	4000	8000	
25	57.8	65.6	67.6	72.9	76.7	74.9	71.5	66.3	81.0
30	57.8	65.6	67.6	72.9	76.7	74.9	71.5	66.3	81.0
35	57.8	65.6	67.6	72.9	76.7	74.9	71.5	66.3	81.0
40	56.3	65.8	66.7	72.9	76.3	75.1	71.3	65.4	80.8
50	61.5	71.0	71.9	77.9	81.3	80.3	76.5	70.6	86.1
60	61.5	71.0	71.9	77.9	81.3	80.3	76.5	70.6	86.1
70	58.7	68.5	69.1	75.1	78.5	77.5	73.7	67.8	83.3
80	58.7	68.5	69.1	75.1	78.5	77.5	73.7	67.8	83.3

In-duct sound power levels at discharge side Units with standard fan motors and pulley opened 4 turns

Sizes	Frequencies (Hz)								Lw global dB(A)
	63	125	250	500	1000	2000	4000	8000	
25	51.8	62.1	63.0	69.0	72.5	71.5	67.5	61.2	77.1
30	51.9	62.1	63.0	69.0	72.6	71.5	67.6	61.5	77.1
35	51.9	62.1	63.0	69.0	72.6	71.5	67.6	61.5	77.1
40	52.8	62.3	63.2	69.2	72.6	71.6	67.8	61.9	77.4
50	58.0	67.5	68.4	74.4	77.8	76.8	73.0	67.1	82.6
60	58.0	67.5	68.4	74.4	77.8	76.8	73.0	67.1	82.6
70	54.8	64.3	65.2	71.2	74.6	73.6	69.8	63.9	79.2
80	54.8	64.3	65.2	71.2	74.6	73.6	69.8	63.9	79.2

In-duct sound power levels at discharge side Units with high static fan motors and completely closed pulley

Sizes	Frequencies (Hz)								Lw global dB(A)
	63	125	250	500	1000	2000	4000	8000	
25	59.1	68.5	69.4	74.5	77.9	76.8	72.7	67.1	82.5
30	59.1	68.5	69.4	74.5	77.9	76.8	72.7	67.1	82.5
35	59.1	68.5	69.4	74.5	77.9	76.8	72.7	67.1	82.5
40	58.0	67.4	63.0	74.8	78.1	76.8	73.0	66.4	82.5
50	64.5	74.0	74.9	80.9	84.3	83.3	79.5	73.6	89.1
60	64.5	74.0	74.9	80.9	84.3	83.3	79.5	73.6	89.1
70	61.5	71.0	71.9	77.9	81.3	80.3	76.5	70.6	86.1
80	61.5	71.0	71.7	77.9	81.3	80.3	76.5	70.6	86.1

In-duct sound power levels at discharge side Units with high static fan motors and pulley opened 4 turns

Sizes	Frequencies (Hz)								Lw global dB(A)
	63	125	250	500	1000	2000	4000	8000	
25	57.5	65.6	67.6	72.9	76.7	74.9	71.5	66.3	80.9
30	57.5	65.6	67.6	72.9	76.7	74.9	71.5	66.3	80.9
35	57.5	65.6	67.6	72.9	76.7	74.9	71.5	66.3	80.9
40	56.3	65.8	66.7	72.9	76.3	75.1	71.3	65.4	80.8
50	61.9	71.4	72.3	78.3	81.7	80.7	76.9	71.0	86.5
60	61.9	71.4	72.3	78.3	81.7	80.7	76.9	71.0	86.5
70	59.1	65.8	66.8	72.9	76.3	75.1	71.3	65.4	80.8
80	59.7	65.5	66.8	72.7	76.3	75.1	71.3	65.4	80.6

Performance Data in Cooling Mode

AQCH Sizes	Outdoor air temperature (°C)														
	LWT (°C)	25		30		32		35		40		43		46	
		Cool. Cap. (kW)	Input power (kW)	Cool. Cap. (kW)	Input power (kW)	Cool. Cap. (kW)	Input power (kW)	Cool. Cap. (kW)	Input power (kW)	Cool. Cap. (kW)	Input power (kW)	Cool. Cap. (kW)	Input power (kW)	Cool. Cap. (kW)	Input power (kW)
25	5	25.0	9.4	24.2	10.2	23.9	10.7	23.3	11.2	21.4	12.4	21.2	12.4	20.2	13.0
	6	25.7	9.5	25.0	10.4	24.6	10.7	24.1	11.4	22.2	12.5	22.0	12.5	20.8	13.1
	7	26.6	9.6	25.9	10.5	25.5	10.9	24.9	11.5	22.9	12.6	22.7	12.6	21.5	13.3
	8	27.4	9.6	26.7	10.6	26.3	11.0	25.8	11.6	23.7	12.6	23.5	12.6	22.3	13.4
	9	28.3	9.7	27.5	10.6	27.2	11.1	26.6	11.8	24.5	12.8	24.3	12.8	23.0	13.5
	10	29.2	9.9	28.4	10.7	28.0	11.1	27.4	11.8	25.3	12.9	25.1	12.9	23.7	13.6
30	5	29.0	10.4	28.1	11.5	27.8	12.0	27.2	12.7	25.1	13.8	23.8	14.7	22.5	15.5
	6	29.8	10.5	29.0	11.6	28.6	12.1	28.0	12.8	25.9	14.0	24.6	14.8	23.3	15.6
	7	30.7	10.7	29.8	11.7	29.5	12.2	28.8	12.9	26.7	14.2	25.3	14.9	24.1	15.7
	8	31.7	10.8	30.8	11.8	30.4	12.3	29.7	13.0	27.4	14.3	26.1	15.0	24.8	15.9
	9	32.5	10.9	31.7	12.0	31.2	12.4	30.6	13.1	28.3	14.3	26.9	15.1	25.6	16.1
	10	33.5	11.0	32.6	12.1	32.1	12.5	31.4	13.3	29.1	14.6	27.7	15.3	26.3	16.2
35	5	34.3	11.8	33.1	12.9	32.5	13.3	31.6	14.0	29.0	15.5	27.4	16.6	25.8	17.6
	6	35.4	12.0	34.1	13.1	33.5	13.4	32.7	14.1	30.0	15.7	28.4	16.7	26.7	17.7
	7	36.4	12.2	35.2	13.2	34.5	13.7	33.7	14.2	31.0	15.8	29.4	16.8	27.7	17.9
	8	37.5	12.3	36.2	13.3	35.7	13.8	34.7	14.3	32.0	16.0	30.4	16.9	28.7	17.9
	9	38.7	12.5	37.4	13.5	36.8	13.9	35.9	14.4	33.2	16.1	31.5	17.1	29.8	18.0
	10	39.8	12.6	38.5	13.7	38.0	14.0	37.1	14.6	34.4	16.1	32.7	17.1	31.1	18.0
40	5	39.5	13.2	38.5	14.5	38.0	15.0	37.2	15.9	34.5	17.4	32.8	18.3	31.1	19.4
	6	40.7	13.3	39.6	14.6	39.1	15.1	38.4	16.0	35.6	17.6	33.9	18.5	32.2	19.5
	7	42.1	13.3	40.9	14.7	40.4	15.3	39.6	16.1	36.7	17.7	34.9	18.6	33.2	19.6
	8	43.3	13.5	42.1	14.8	41.7	15.4	40.9	16.2	37.9	17.8	36.1	18.7	34.3	19.8
	9	44.6	13.6	43.4	14.9	42.9	15.5	42.1	16.3	39.1	17.9	37.1	18.9	35.3	19.9
	10	45.9	13.7	44.8	15.0	44.2	15.6	43.4	16.5	40.2	18.0	38.3	19.1	36.5	20.0
50	5	46.5	18.1	45.1	19.8	44.6	20.5	43.6	21.6	40.1	23.5	38.1	24.8	36.1	26.0
	6	47.9	18.2	46.4	20.0	45.8	20.7	44.8	21.8	41.4	23.8	39.3	25.0	37.2	26.2
	7	49.2	18.5	47.7	20.2	47.2	20.9	46.2	22.0	42.6	24.0	40.5	25.2	38.3	26.5
	8	50.6	18.7	49.2	20.3	48.5	21.1	47.5	22.2	43.8	24.3	41.7	25.5	39.5	26.9
	9	51.9	18.8	50.5	20.6	49.8	21.3	48.8	22.4	45.1	24.5	42.8	25.8	40.7	27.1
	10	53.3	19.0	51.8	20.8	51.2	21.6	50.2	22.7	46.3	24.8	44.1	26.1	41.8	27.4
60	5	56.3	21.0	54.8	22.9	54.1	23.7	53.1	25.0	49.0	27.3	46.6	28.7	44.2	30.1
	6	58.0	21.1	56.4	23.2	55.7	24.0	54.6	25.2	50.5	27.6	48.0	29.0	45.6	30.4
	7	59.8	21.4	58.1	23.4	57.5	24.2	56.3	25.5	52.1	27.8	49.5	29.2	47.0	30.8
	8	61.5	21.7	59.8	23.6	59.1	24.5	58.1	25.8	53.6	28.2	51.0	29.6	48.4	31.1
	9	63.3	21.8	61.6	23.8	60.8	24.7	59.7	26.0	55.3	28.4	52.5	29.9	49.8	31.4
	10	65.1	22.0	63.4	24.1	62.7	25.0	61.5	26.3	56.8	28.7	54.0	30.2	51.2	31.8
70	5	67.5	23.5	65.7	25.6	64.9	26.5	63.6	27.9	58.8	30.5	55.9	32.1	53.0	33.7
	6	69.5	23.6	67.6	25.9	66.8	26.8	65.5	28.2	60.6	30.8	57.6	32.4	54.7	33.9
	7	71.6	23.9	69.7	26.2	68.9	27.1	67.5	28.1	62.4	31.1	59.4	32.7	56.3	34.4
	8	73.8	24.2	71.7	26.4	70.9	27.4	69.6	28.8	64.3	31.5	61.1	33.1	58.0	34.8
	9	75.9	24.3	73.9	26.6	72.9	27.6	71.6	29.1	66.2	31.8	62.9	33.4	59.7	35.1
	10	78.1	24.6	76.0	26.9	75.1	27.9	73.7	29.4	68.1	32.1	64.8	33.8	61.4	35.5
80	5	77.0	26.4	74.7	28.8	73.9	29.7	72.3	31.4	66.5	34.3	63.2	36.0	59.9	37.8
	6	79.3	26.5	76.9	29.1	75.9	30.1	74.4	31.7	68.6	34.6	65.2	36.3	61.7	38.1
	7	81.4	26.9	79.1	29.4	78.1	30.4	76.6	32.0	70.6	34.9	67.1	36.7	63.6	38.6
	8	83.7	27.2	81.4	29.6	80.3	30.7	78.7	32.3	72.7	35.4	69.1	37.1	65.4	39.1
	9	86.0	27.3	83.6	29.9	82.4	31.0	80.9	32.6	74.7	35.7	70.9	37.5	67.4	39.4
	10	88.3	27.7	85.8	30.2	84.8	31.4	83.2	33.0	76.7	36.0	73.1	37.9	69.3	39.9

LWT : leaving water temperature.

Power input values are given for compressors and fan motor.

Performance Data in Heating Mode

AQCH Sizes	Outdoor air temperature (°C)														
	LWT (°C)	-5		-3		0		5		7		10		15	
		Heat. Cap. (kW)	Input power (kW)	Heat. Cap. (kW)	Input power (kW)	Heat. Cap. (kW)	Input power (kW)	Heat. Cap. (kW)	Input power (kW)	Heat. Cap. (kW)	Input power (kW)	Heat. Cap. (kW)	Input power (kW)	Heat. Cap. (kW)	Input power (kW)
25	30	18.4	8.7	20.2	8.7	22.5	8.8	26.6	8.9	29.2	8.9	31.1	9.1	35.9	9.2
	35	18.4	9.5	20.2	9.5	22.3	9.6	26.2	9.6	28.6	9.8	30.5	9.8	35.1	9.9
	40	18.4	10.3	20.0	10.3	22.0	10.5	25.7	10.5	28.1	10.6	29.9	10.7	34.3	10.7
	45	18.3	11.1	19.7	11.1	21.7	11.3	25.3	11.4	27.6	11.5	29.3	11.6	33.5	11.8
	50					21.3	12.2	24.9	12.3	27.1	12.5	28.6	12.7	32.6	12.8
30	30	21.5	9.7	23.6	9.7	26.3	9.8	31.1	10.0	34.0	10.0	36.3	10.1	41.8	10.3
	35	21.5	10.6	23.5	10.6	26.0	10.8	30.5	10.8	33.4	10.9	35.6	10.9	40.9	11.1
	40	21.5	11.6	23.4	11.6	25.7	11.7	30.0	11.9	32.8	11.9	34.8	12.0	40.0	12.0
	45	21.4	12.5	23.0	12.5	25.3	12.7	29.5	12.9	32.2	12.9	34.1	13.1	39.1	13.2
	50					24.9	13.7	29.0	14.0	31.7	14.1	33.4	14.3	38.1	14.4
35	30	25.4	10.4	27.2	10.3	30.0	10.4	35.2	10.3	37.4	10.3	40.3	10.4	45.6	11.0
	35	25.4	11.6	27.2	11.5	29.9	11.4	35.0	11.3	37.2	11.2	39.9	11.5	45.0	12.0
	40	25.3	12.9	27.0	12.7	29.8	12.5	34.6	12.4	36.8	12.3	39.4	12.6	44.4	13.1
	45	25.3	14.4	27.0	14.1	29.7	13.8	34.2	13.6	36.3	13.5	38.8	13.9	43.7	14.4
	50					29.7	15.1	33.8	14.8	35.8	14.8	38.1	15.3	42.9	15.8
40	30	30.9	11.7	32.9	11.8	36.3	11.9	42.1	12.0	45.8	12.1	48.3	12.1	55.1	12.3
	35	31.3	12.8	32.6	12.9	35.9	13.1	41.6	13.3	45.2	13.3	47.6	13.4	54.2	13.5
	40	30.2	14.0	32.3	14.2	35.5	14.4	41.0	14.6	44.5	14.7	46.9	14.8	53.2	15.0
	45	30.0	15.4	32.0	15.6	35.1	15.8	40.5	16.1	43.9	16.2	46.1	16.4	47.5	16.5
	50					37.6	17.4	39.9	17.7	43.2	17.9	45.4	18.0	51.3	18.2
50	30	38.9	16.5	41.6	16.6	45.8	16.7	53.1	16.9	57.8	17.0	61.0	17.1	69.6	17.3
	35	39.5	17.7	41.1	17.9	45.3	18.1	52.4	18.4	57.0	18.5	60.0	18.6	68.3	18.8
	40	38.1	19.2	40.7	19.4	44.8	19.7	51.7	20.1	56.2	20.2	59.1	20.3	67.1	20.5
	45	37.8	20.9	40.3	21.1	44.3	21.5	51.1	21.9	55.4	22.0	58.2	22.3	59.9	22.4
	50					43.7	23.3	50.3	23.8	54.5	24.0	57.2	24.2	64.7	24.5
60	30	46.5	19.1	49.7	19.2	54.7	19.3	63.4	19.6	69.0	19.6	72.8	19.7	83.1	20.0
	35	47.2	20.6	49.2	20.8	54.1	21.1	62.7	21.4	68.1	21.5	71.7	21.6	81.6	21.8
	40	45.5	22.5	48.7	22.7	53.5	23.1	61.8	23.5	67.2	23.6	70.6	23.7	80.2	23.9
	45	45.2	24.5	48.2	24.8	52.9	25.2	61.0	25.7	64.2	25.8	69.5	26.1	71.6	26.3
	50					52.2	27.5	60.1	28.0	65.1	28.3	68.4	28.5	77.3	28.8
70	30	55.2	21.3	58.9	21.5	64.9	21.7	75.3	21.9	81.9	22.0	86.4	22.1	98.7	22.3
	35	56.0	23.1	58.3	23.3	64.2	23.6	74.4	24.0	80.8	24.1	85.1	24.2	96.9	24.4
	40	54.1	25.1	57.7	25.4	63.5	25.8	73.3	26.3	79.7	26.4	83.8	26.6	95.2	26.8
	45	53.6	27.4	57.2	27.8	62.8	28.2	72.4	28.7	76.2	28.1	82.5	29.2	84.9	29.4
	50					62.0	30.8	71.3	31.4	77.3	31.6	81.2	32.0	91.7	32.3
80	30	60.9	23.8	65.0	23.9	71.5	24.1	83.0	24.4	90.3	24.5	95.3	24.6	108.8	24.9
	35	61.7	25.7	64.3	26.0	70.8	26.3	82.0	26.7	89.1	26.8	93.9	27.0	106.8	27.2
	40	59.6	28.0	63.7	28.3	70.0	28.8	80.9	29.3	87.9	29.4	92.4	29.6	104.9	29.9
	45	59.1	30.5	63.0	31.0	69.2	31.4	79.8	32.0	84.0	31.6	90.9	32.6	93.6	32.8
	50					68.3	34.3	78.6	35.0	85.2	35.2	89.5	35.6	101.1	35.9

LWT : leaving water temperature.

Power input values are given for compressors and fan motor.

Hydraulic Pump External Static Pressure

Models 25 & 30

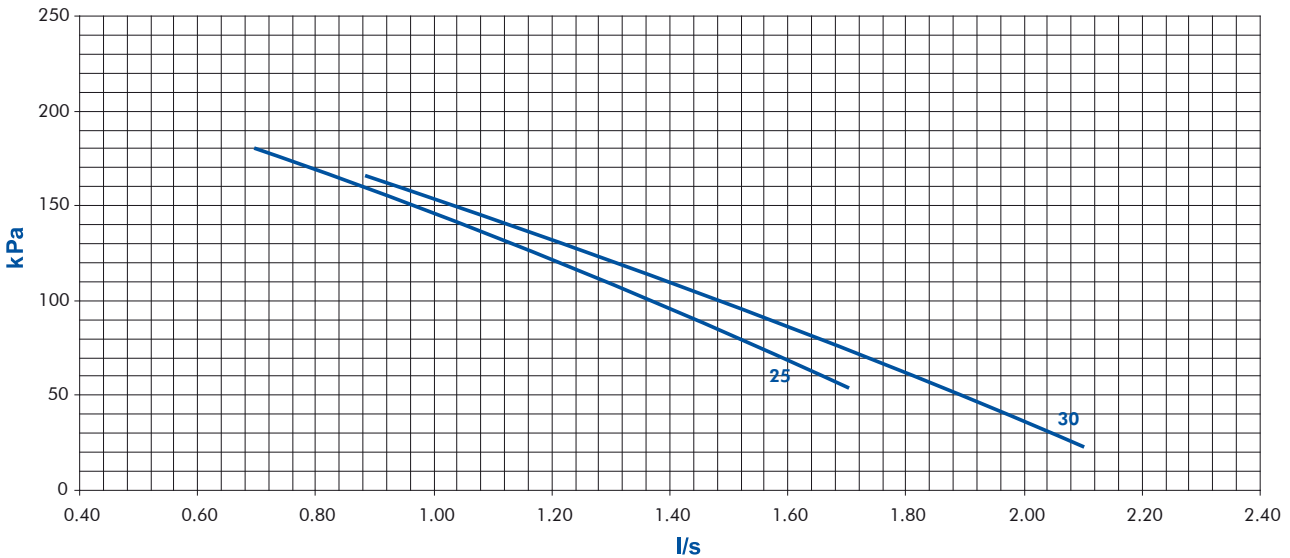

Cooling mode

Water flow (l/s)	Model 25	Model 30
Nominal (1)	1.04	1.29
Minimum (2)	0.7	0.86
Maximum (3)	1.73	2.15

- (1) Eurovent conditions, Water : 12 / 7 °C, Air : 35 °C.
- (2) With water Δt : 7.5 K at nominal capacity.
- (3) With water Δt : 3 K at nominal capacity.

Heating mode

Water flow (l/s)	Model 25	Model 30
Nominal (1)	1.22	1.35
Minimum (2)	0.80	0.98
Maximum (3)	1.83	2.15

- (1) Eurovent conditions, Water : 40 / 45 °C, Air : 7 °C.
- (2) With water Δt : 7.5 K at nominal capacity.
- (3) With water Δt : 3 K at nominal capacity.

Models 35, 40, 50, 60, 70 & 80

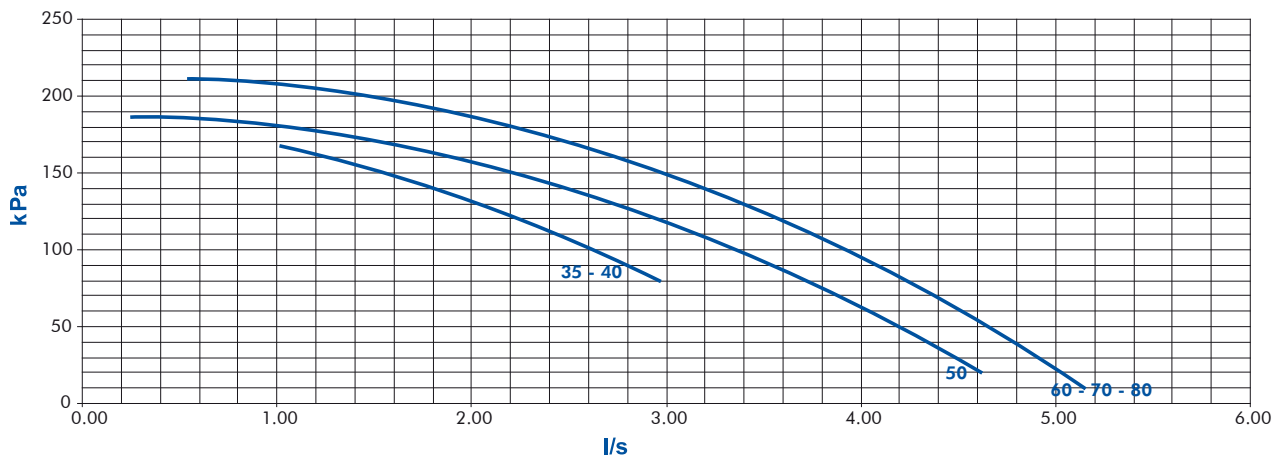

Cooling mode

Water flow (l/s)	Model 35	Model 40	Model 50	Model 60	Model 70	Model 80
Nominal (1)	1.60	1.75	2.16	2.75	3.08	3.2
Minimum (2)	1.07	1.16	1.45	1.80	2.1	2.3
Maximum (3)	2.68	2.92	3.58	4.56	5.09	5.3

- (1) Eurovent conditions, Water : 12 / 7 °C, Air : 35 °C.
- (2) With water Δt : 7.5 K at nominal capacity.
- (3) With water Δt : 3 K at nominal capacity.

Heating mode

Water flow (l/s)	Model 35	Model 40	Model 50	Model 60	Model 70	Model 80
Nominal (1)	1.67	1.87	2.20	2.80	3.64	4.01
Minimum (2)	1.20	1.35	1.50	1.90	2.43	2.68
Maximum (3)	2.70	3.05	3.60	4.60	6.07	6.69

- (1) Eurovent conditions, Water : 40 / 45 °C, Air : 7 °C.
- (2) With water Δt : 7.5 K at nominal capacity.
- (3) With water Δt : 3 K at nominal capacity.

Remark : the hydraulic pump external static pressure curves are based on water average temperature of 10 °C.

Heat Exchanger Water Pressure Drop

Models 25, 30 & 35

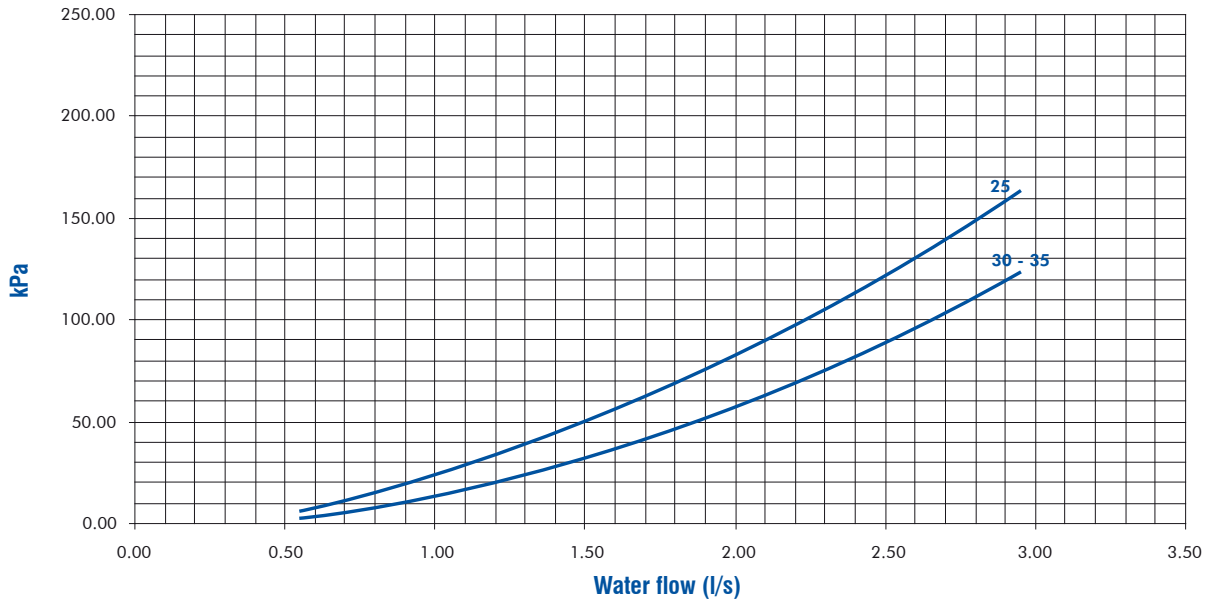

Models 40, 50, 60, 70 & 80

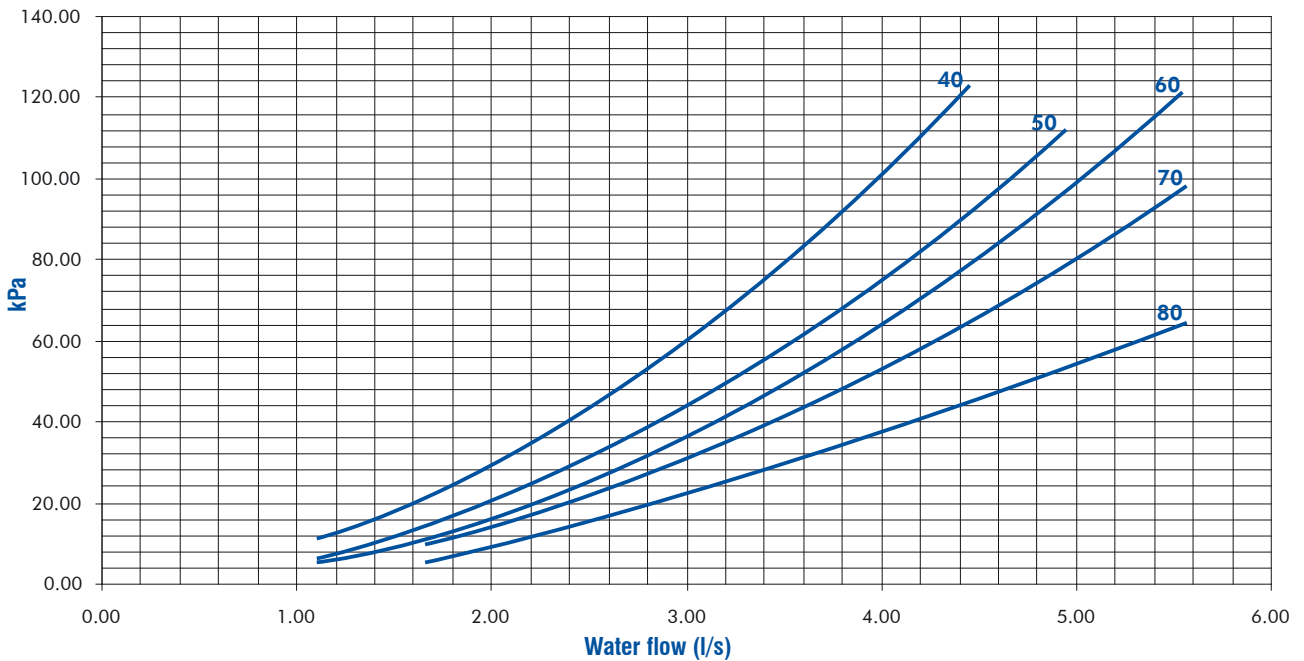

Remark : the heat exchanger water pressure drop curves are based on water average temperature of 10 °C. For temperatures different from 10 °C, use the correction factors as stated below :

Water average temperature (°C)	5	10	15	20	30	40	50
Correction factors	1.02	1.00	0.98	0.97	0.95	0.93	0.91

Dimensions (mm)

Unit overall dimensions

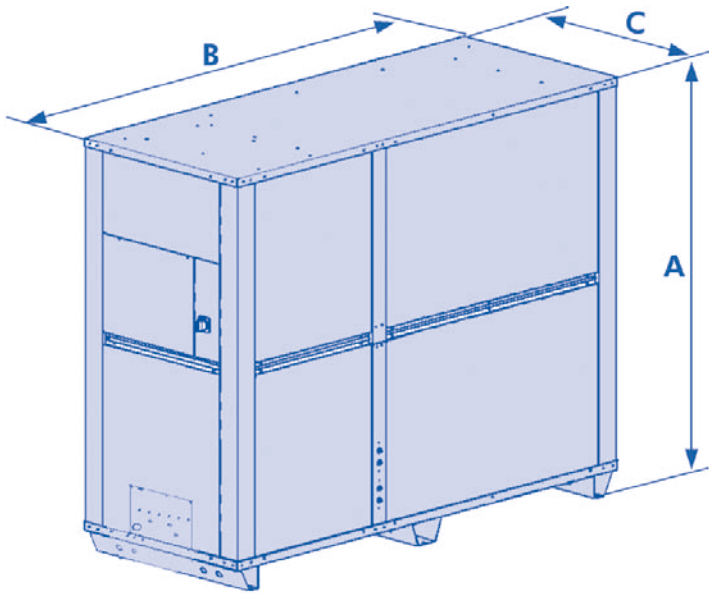

AQCH sizes	A	B	C
25	1505	1752	890
30	1505	1752	890
35	1505	1752	890
40	1773	2206	890
50	1773	2206	890
60	1773	2206	890
70	2313	2464	1100
80	2313	2464	1100

Standard blowing

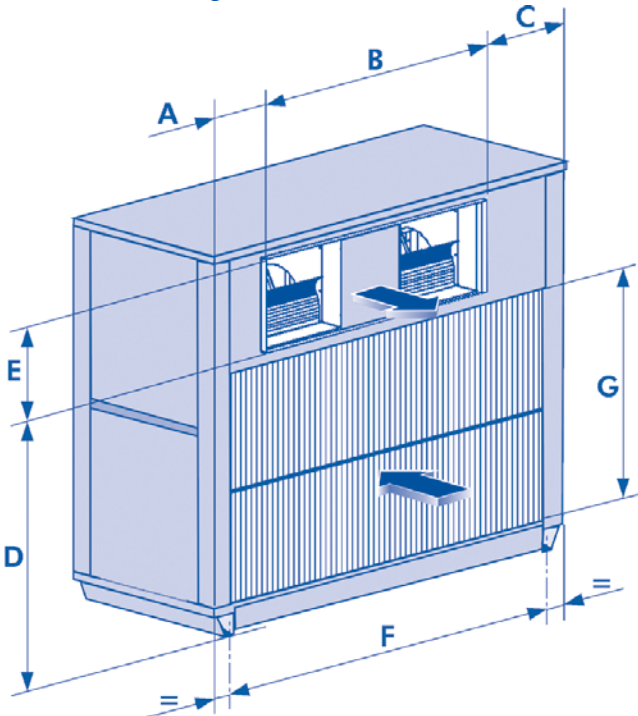

AQCH sizes	A	B	C	D	E	F	G
25	149.5	1348	254.5	1115	348	1500	950
30	149.5	1348	254.5	1115	348	1500	950
35	149.5	1348	254.5	1115	348	1500	950
40	285.5	1388	532.5	1275	450	2110	1085
50	285.5	1388	532.5	1275	450	2110	1085
60	285.5	1388	532.5	1275	450	2110	1085
70	315	1604	545	1745	500	2240	1500
80	315	1604	545	1745	500	2240	1500

Dimensions (mm)

Opposite blowing

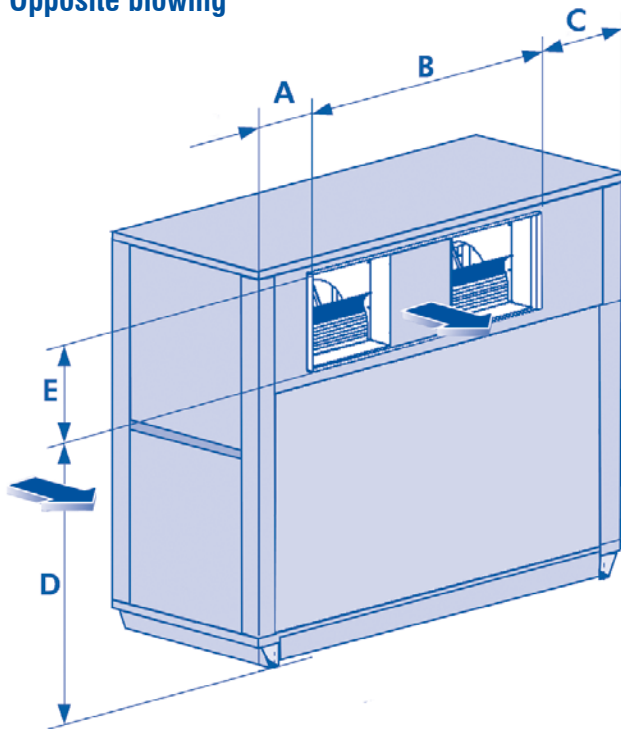

AQCH sizes	A	B	C	D	E
25	252	1348	152	1115	348
30	252	1348	152	1115	348
35	252	1348	152	1115	348
40	649.5	1388	168.5	1275	450
50	649.5	1388	168.5	1275	450
60	649.5	1388	168.5	1275	450
70	549.5	1604	310.5	1745	500
80	549.5	1604	310.5	1745	500

Vertical blowing

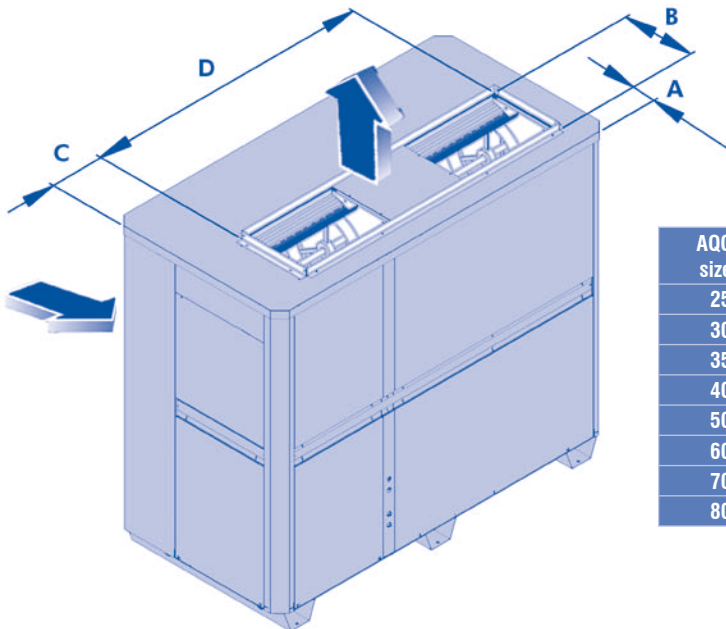

AQCH sizes	A	B	C	D
25	63	443	188	1488
30	63	443	188	1488
35	63	443	188	1488
40	215	445	595	1490
50	215	445	595	1490
60	215	445	595	1490
70	150	500	544	1600
80	150	500	544	1600

Water Connection Side and Electrical Access

Standard blowing

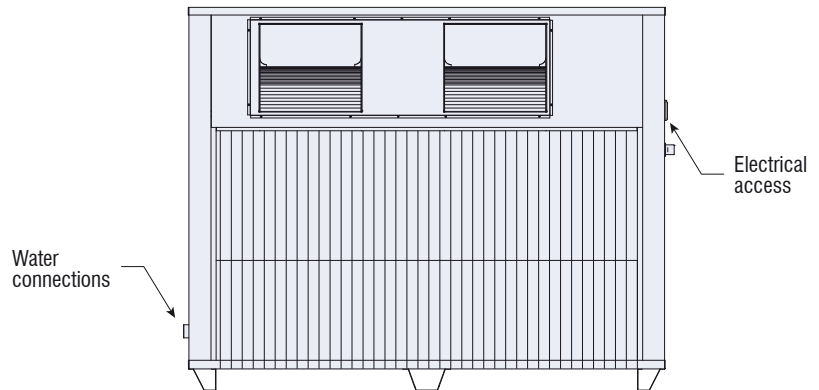
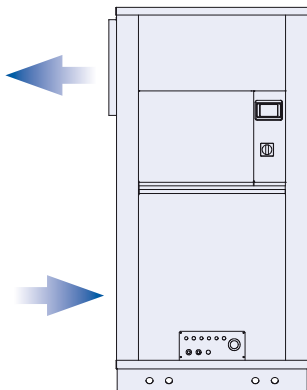

Vertical blowing

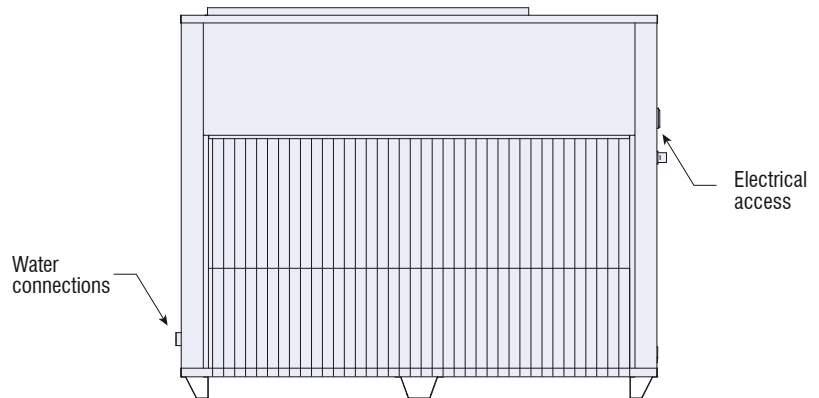

Opposite blowing

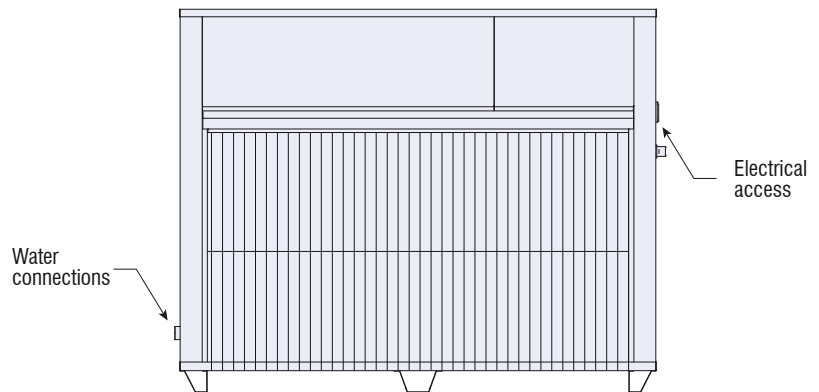
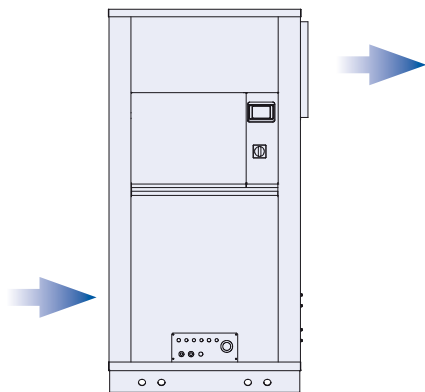

Water Connections

AQCH 25-30-35

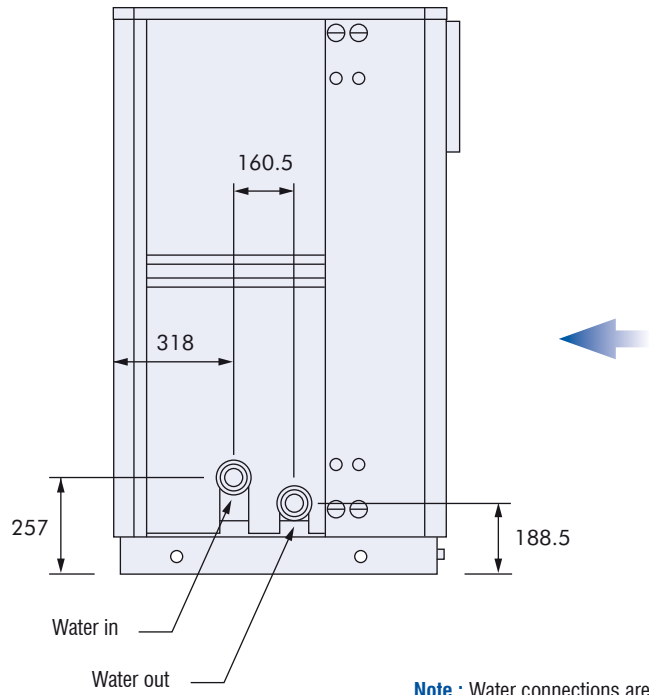

AQCH 40-50-60-70-80

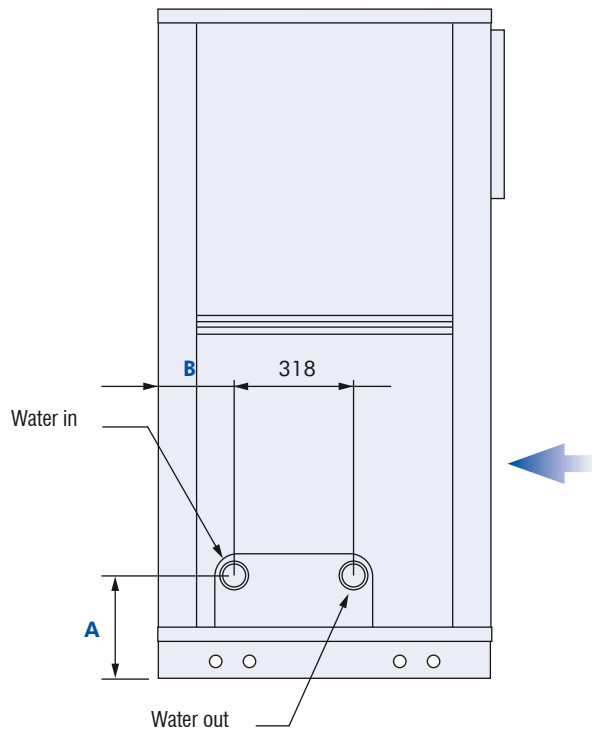

AQCH sizes	A (mm)	B (mm)
40 - 50 - 60	274	202.5
70 - 80	344	306

Note : Water connections exceed about 50 mm to exterior.

Minimum Clearance Around the Unit

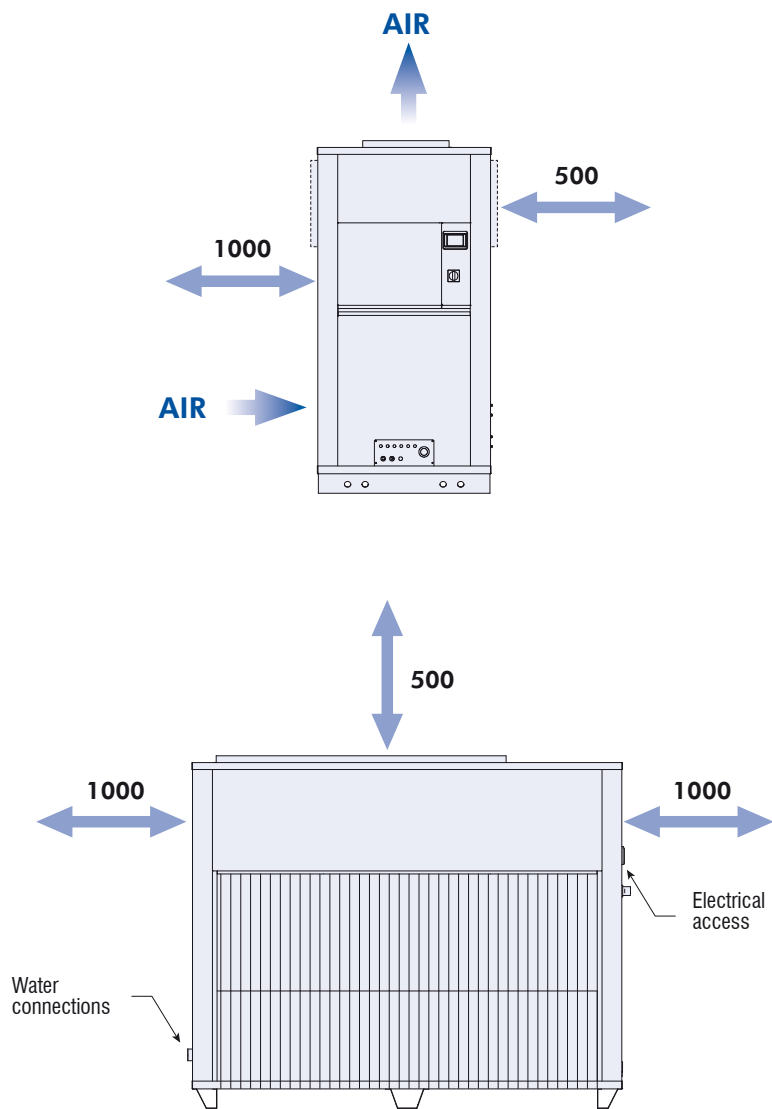

Dimensions in mm.



AIRWELL France SAS
1 bis, Avenue du 8 mai 1945
Saint Quentin en Yvelines
78284 GUYANCOURT
France
Tel. +33 (0) 01 39 44 78 00
Fax +33 (0) 01 39 44 65 17

Ref. : EDM AQCH-A.6GB/03.10 - Supersedes : EDM AQCH-A.5GB/06.09

As part of our ongoing product improvement programme, our products are subject to change without prior notice. Non contractual photos.