



Close Control Modular Range



**Water Cooled Units
Installation, Operation & Maintenance Manual
50Hz/60Hz**

Index

Description	Page
INSTALLATION	
General	3
Mechanical Installation	4
Water Cooled Units	5
Water and Drain Connections	6
General Engineering Data	7
Electrical Connections	8
OPERATION	
General	16
Heating Operation	17
Cooling Operation	17
Dehumidification Control	18
Humidification Cycle	18
PGD Display	20
Alarms	21
MAINTENANCE	
General	22
Common Components	22
Water/Water Freecooling Units	24
Electric Panel – Inspection & Functional Tests	24
Steam Humidifier Canister Cleaning & Removal	25
Thermostatic Expansion Valve – Calibration	25
Plate Heat Exchanger Cleaning	26
Water Regulating Valves	26
Refrigerant Control Settings	26
Fault Finding Guide	27
Monthly Maintenance Inspection Check	30
Annual Maintenance Inspection Check	31

INSTALLATION

GENERAL

INSPECTION

On receiving the equipment it should be checked to ensure that it is complete and in perfect condition. The carrier should be notified immediately, in writing, of any damage that might have been caused in transit.

HANDLING

Always keep the unit vertically upright and do not leave it out in the open. The unit can be moved with a pallet truck. If a forklift is being used ensure the forks extend beyond the pallet. Care should be taken not to damage the bottom of the unit. If a crane is being used to move the unit leave the packaging intact and place spreader bars across the top of the unit to prevent the slings causing damage. The unit should be moved as near as possible to the installation position before removing the cardboard packing and the pallet.

UNPACKING THE UNIT

- 1) Cut the three straps binding the unit taking care to avoid any backlash caused by their tightness.
- 2) Remove the lid.
- 3) The cardboard sleeve will then unravel itself revealing a plastic dust cover.
- 4) Remove dust cover. If it is a downflow model, to remove the front panels use the key attached to the sensor on the top of the unit. Front return units have the bottom front panel shipped separately.
- 5) Remove the two bolts securing the unit to the skid (19 mm spanner).
- 6) Manoeuvre the unit carefully from the pallet. If it is necessary, use rollers underneath the unit to locate it in its final position.
- 7) If the unit requires a plenum fix same before final positioning.
- 8) Ensure the unit is positioned on a level floor.

POSITIONING

Single Circuit Units.

The Modular Range is built on a level base and its positioning is most important. The unit should be firmly supported on the floor itself or on an optional floor stand.

Ensure that the unit is level in all directions as failure to do so will result in operational problems, particularly with regards to drainage. Care should be taken in manoeuvring the unit as the paintwork could be damaged. Use rollers where possible and apply pressure to the bottom of the unit for final positioning. Before final positioning ensure that inaccessible panels are correctly fitted and plenums are secured.

Duplex/Twin Circuit/Twin Circuit Units

Follow the same instructions as above, if however unit is in 2 modules ensure the control unit (master) is on the right. The only extras involved in the Duplex/Twin Circuit/Twin Circuit Modular Range unit are the interconnection harnesses. The length of these harnesses dictates the distance between the master and slave. (Typical harness length approx. 1 m, allow for cable routing when positioning)

The knockouts on the side panels for routing the harnesses. These are located in the base of the slave unit and are to be connected to the relevant contactors and connection on the master module. The harnesses for connection include a power harness for the fan motor, a control harness for the controls and a power harness for the compressor where applicable. The control harness plugs into J12 socket of the master. This is for wiring the pressure switches, airflow switch, etc.

ATTACHING THE PLENUM

The plenum and unit are pre-drilled. At the time of installation remove the grilles from the plenum and secure the plenum internally by means of self tapping screws provided. Also secure to the back of the unit.

SERVICE ACCESS

Downflow Units

Service of a down flow unit can be generally completed from the front of the unit. To remove certain components from the unit it may be easier and quicker to have side access to assist in these operations.

When positioned there should be a minimum clearance in front of the unit of 0.6m. It is strongly recommended to leave a distance of 0.6m at both sides of the unit. Access to the back of the unit is not necessary. There is a minimum distance of 150mm needed above the unit to allow removal of the filters.

Upflow Units

Unlike the down flow, side access is necessary for servicing the up flow. When installing ensure the left-hand side of the unit has access for the purpose of servicing, especially the motor. On the small frame the motor is actually mounted 'piggy-back' on the blower and on the mid and large frame the motor is located on the left-hand side of the blower

On the Modular Range Duplex/Twin Circuit/Twin Circuit up flow units the fan motor arrangement is such that access is required at either end of the unit. The master's motor is located to the left of the blower as standard while the slave's motor is configured to the right hand side of the blower. Access to the back of the unit is not required. It is strongly recommended to leave a distance of 0.6m at both sides of the unit. The filters are located in the bottom front panel; a minimum distance of 1m is needed to allow the return air to enter the unit.

Space above the unit will be determined by location. If a standard plenum is being installed the overall height of the unit is extended to 2380mm

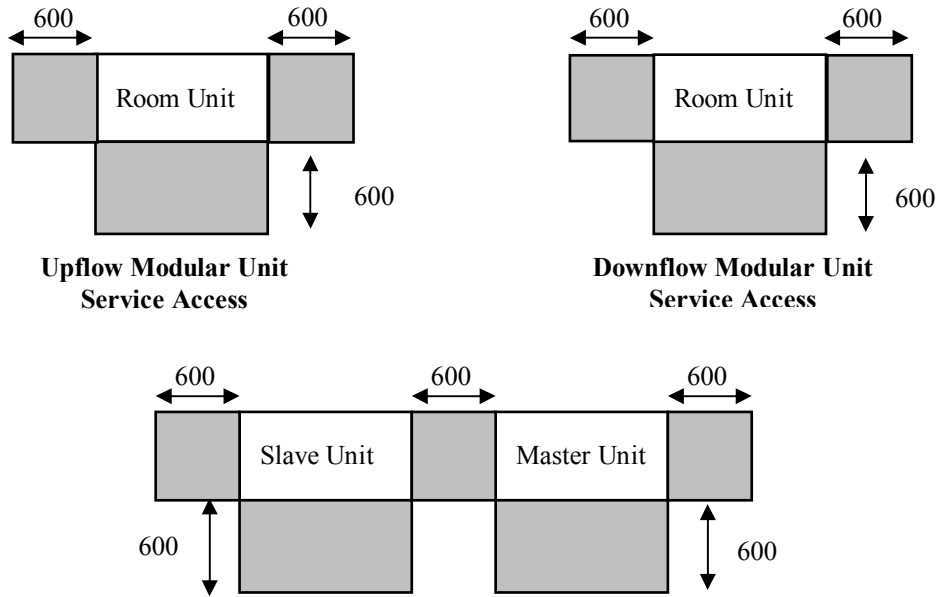

**Upflow Modular Unit
Service Access**

**Downflow Modular Unit
Service Access**

Downflow/Upflow Duplex/Twin Circuit Unit Service Access

Centre access space is highly recommended. Always position master unit on right hand side.

MECHANICAL INSTALLATION

SYSTEM APPLICATION

To achieve maximum performance and efficient energy usage following considerations should be given.

- 1) The room should be sealed effectively against air and vapour to minimise the loss and infiltration of uncontrolled humidity through concrete slab, walls, ceiling, roof, doors or any other opening or aperture.
- 2) Room location and orientation should be considered with regard to heat load and external variables should be reduced to a minimum.
- 3) The room should be kept at a positive pressure by introduction of pre-treated fresh air.
- 4) Low resistance to conditioned air distribution can be achieved by providing the maximum raised flooring height, minimum cable bunching and correct position of pipework (i.e. parallel to air flow).
- 5) Pipework that is not isolated or is fastened inadequately can transmit vibration along its full length.

WATER COOLED UNITS

The units are shipped with the refrigeration system vacuumed and fully charged. The pipework for the waterside has been tested in the factory. The test pressure has been discharged and the pipes capped and labelled for inlet and outlet connection. For each compressor, there is a brazed plate heat exchanger (condenser) and a water regulating valve. Connection of the water supply (in) and return (out) pipes are required to complete the system. These pipes are clearly marked. The water pressure should not exceed 1000kPa. The installation of a 1mm maximum mesh filter to prevent condenser fouling should be part of the installation pipework or located elsewhere in the system with isolation of the filter for servicing. Isolating and/or balancing and automatic bleed valves are recommended to facilitate commissioning, maintenance, repair, or relocation of the unit.

WATER PIPING

The water cooled condenser is factory fitted with a water regulating valve. These valves regulate the water quantity from the head pressure of the matching refrigerant circuit. It is recommended that manual shut-off valves be installed at the supply and return line to each indoor unit. This will provide for routine service or emergency isolation of the unit. Gate valves should also be installed to isolate pump(s) and prevent loss of water and Water when service is required on the pump(s). Manually operated vents must be installed on the top of any pipe which can trap air. Manual venting is necessary to rid the system of air which can vapour lock the pipe and prevent proper flow of liquid. The minimum Water temperature to be supplied from the drycooler should be determined as if the fluid temperature drops below the conditioned air dewpoint the Water supply and return lines will need to be insulated. The insulation used should be closed cell material (e.g. Armaflex or equivalent). The cooling water pressure should not exceed 1000 kPa A pressure relief valve is fitted on the refrigerant circuit & this needs to be piped to atmosphere.

System Components

1. Evaporator Coil.
2. Liquid Distributor.
3. Thermostatic Expansion Valve (externally equalised).
4. Liquid Sight Glass (including moisture indicator).
5. Filter Drier
6. Compressor.
7. Compressor Service Valves.
8. High Pressure Switch
9. Low Pressure Switch (auto. reset).
10. Pressure Relief Valve
11. Plate Heat Exchanger
12. Water Regulating Valve
13. Isolating Valves

Note: Item 13 is field fitted by others.

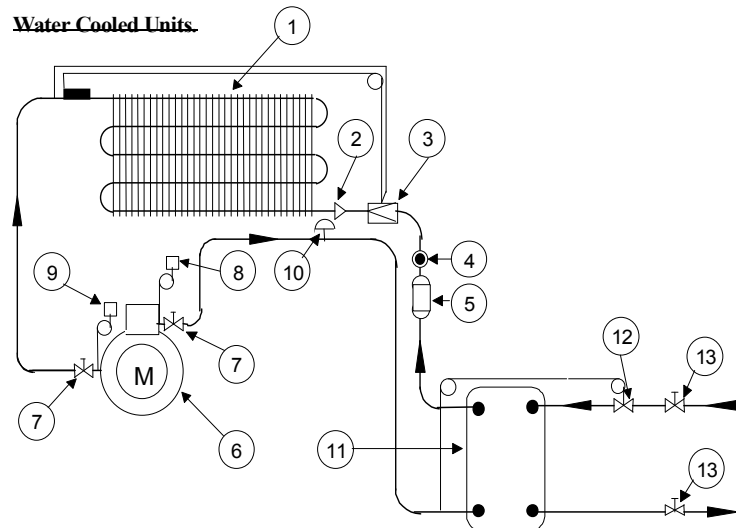

WATER REGULATING VALVE (WRV)

Water condensers are fitted with a water regulating valve. These valves regulate the water flow through the condenser from the head pressure of the matching refrigeration circuit. The water regulating valves are fitted with an adjusting screw on top of the valve. This controls the operation of the head pressure over which the valve operates. The valve can be adjusted with a standard refrigeration service valve wrench or screw driver.

- 1) To lower the head pressure setting, turn the square adjusting screw clockwise until the high pressure gauge indicates the desired setting.
- 2) To raise the head pressure setting, turn the adjusting screw counter clockwise until the desired setting is achieved.

SETTING THE THERMOSTATIC EXPANSION VALVE

The thermostatic expansion valve is factory-set but if for some reason, the superheat needs to be adjusted, uses the following procedure.

- 1) Have the unit running as near as possible to design conditions. The compressor should be running for a period of at least 30 mins. before any adjustment should be undertaken.
- 2) Measure the superheat as follows:
 - a) Measure temperature at the point where the expansion valve sensing bulb is located. A contact thermometer can be used for this purpose.
 - b) Obtain suction pressure at the compressor suction rotolock valve and convert by use of a temp/press chart.
 - c) The superheat value is the difference between the two readings.
- 3) The superheat value must be 7 - 8°C; if not, set the expansion valve as follows:
 - a) Remove the protective cover.
 - b) As the thermostatic exp. valve is a finely balanced regulator it is strongly advised that the stem is adjusted only half a turn at a time.
 - c) Wait for 30 mins.
 - d) Measure the superheat again and repeat the operation, if necessary. To **reduce** the superheat adjust stem **anti-clockwise**. To **increase** the superheat adjust stem **clockwise**

WATER AND DRAIN CONNECTIONS

WATER SUPPLY

Water is fed from the mains supply to the humidifier inlet solenoid valve. The connection to the solenoid valve is a 3/4" male connection. The feed water characteristics should comply with the following values:

Characteristic	Minimum	Maximum
Feed Water Pressure	1 bar	10 bar
Electric Conductivity at 25°C	400 µS/cm	800 µS/cm
Impurity Size	-	0.1 mm
Feed Water Hardness – French Degrees	15	30

In the case of high water pressure a pressure reducing valve calibrated to between 3 - 4 bar should be fitted. Inlet water temperature must not exceed 50°C. It is recommended to install a shut-off valve and a mechanical filter with the wire mesh size less than 50µm. The humidifier pan drain connection is a 22 mm female connection. The humidifier drain can be discharged into the standard drainage system via a rubber or plastic hose suitable for temperatures up to 100°C. The hose should have a minimum internal diameter of 22mm. A trap or vertical loop should be fitted in the tubing to prevent blow back or odours and ensure that the drain has a fall of not less than 1:50.

Note: Do not feed demineralised water into the humidifier.

CONDENSATE DRAIN

Install a drain pipe from the base of the drain pan (typically a 1" female B.S.P. fitting). Insulating this drain pipe is not necessary. It is advised to fit a trap in this drainpipe. On a Duplex/Twin Circuit unit there are knockouts on the side panels to route drain hoses through to a single outlet. Copper pipe should be used for drains on units with humidifiers.

If the system is equipped with a condensate pump, install a check valve on the discharge line of the pump to prevent backfilling the pump reservoir.

GENERAL ENGINEERING DETAILS								
Downflow or Upflow Module								
Module Size		10	15	20	25	30	35	40
All Heat Reject Types								
Coil Data								
Coil Face Area - DX	m ²	0.60	0.60	0.82	0.82	1.10	1.10	1.34
Coil Face Area – C.Water & ECX	m ²	0.60	0.60	0.82	0.82	1.10	1.10	1.34
Rows	-	4	4	4	4	4	4	4
Coil Drain Connection BSPF	inch	¾	¾	¾	¾	¾	¾	¾
Air Side Data								
Air Volume	m ³ /hr	3000	4500	6000	7500	9000	10500	12000
External Static Pressure ESP	Pa	75	75	75	75	75	75	75
Standard FC Centrifugal Fan								
Fan Motor	kW	0.75	1.10	1.50	2.20	2.20	3.00	4.00
No. of Fans	-	1	1	1	1	1	1	1
Optional EC Plug Fan								
Quantity		1	1	1	1	1	1	1
Fan Diameter		450	450	500	500	500	560	630
Fan Motor	kW	1.0	1.0	2.7	2.7	2.7	3.1	2.9
Fan Absorbed Power	kW	0.4	0.8	0.9	1.3	2.0	2.2	2.3
Filter Data								
Downflow Filter Size Code	-	1	1	2	2	3	3	1
Downflow Filter Quantity	No.	2	2	4	4	4	4	4
Upflow Filter Size Code	-	1	1	2	2	3	3	4
Upflow Filter Quantity	No.	1	1	2	2	2	2	2
Humidifier Data								
Inlet Connection BSPM	inch	1	1	1	1	1	1	1
Drain Connection BSPF	inch	1	1	1	1	1	1	1
Water Feed Pressure	bar	1-10	1-10	1-10	1-10	1-10	1-10	1-10
French Degrees Water Hardness	-	15-30	15-30	15-30	15-30	15-30	15-30	15-30
Noise Data								
Freefield SPL	dBA	53	55	54	56	55	57	59
Air Cooled Units								
Discharge Connection Size	mm	16	16	22	22	22	22	28
Liquid Connection Size	mm	12	12	12	16	16	16	16
Condenser Conns. Inlet/Outlet 30 °C	mm	22/18	22/18	22/18	22/20	28/22	28/22	28/22
Condenser Conns. Inlet/Outlet 35 °C	mm	22/18	22/18	28/22	28/22	28/22	28/22	28/22
Condenser Conns. Inlet/Outlet 40 °C	mm	28/22	22/20	28/22	28/22	28/22	35/28	35/28
Condenser Conns. Inlet/Outlet 45 °C	mm	22/20	28/22	28/22	35/28	35/28	42/35	42/35
Scroll Compressor -50Hz	-	ZR48	ZR72	ZR94	ZR108	ZR144	ZR160	ZR190
Scroll Compressor -60Hz	-	ZR40	ZR61	ZR81	ZR94	ZR108	ZR144	ZR160
Water, Glycol & ECX Cooled								
Condenser Water F&R Pipe Size	mm	25	25	32	32	32	32	32
Drycooler Conns. Inlet/Outlet 30 °C	mm	25	25	32	32	40	40	40
Drycooler Conns. Inlet/Outlet 35 °C	mm	25	32	40	40	50	50	50
Drycooler Conns. Inlet/Outlet 40 °C	mm	25	32	40	40	50	50	50
Drycooler Conns. Inlet/Outlet 45 °C	mm	32	40	50	50	65	65	65
Scroll Compressor - 50Hz	-	ZR48	ZR72	ZR94	ZR108	ZR144	ZR160	ZR190
Scroll Compressor - 60Hz	-	ZR40	ZR61	ZR81	ZR94	ZR108	ZR144	ZR160
Chilled Water Cooled								
Chilled Water F&R Pipe Size	mm	28	28	35	35	35	35	35
Control Valve Size	mm	25	25	25	25	32	32	32
Control Valve Kv	-	6.3	6.3	10.0	10.0	16.0	16.0	16.0

Notes:

- Indoor unit Freefield SPL dBA levels are measured at 3m. For Duplex or Twin Circuit Units add 3dBA.
- Data is for one module only. For Duplex or Twin Circuit Units, the data must be multiplied accordingly.
- Downflow Filter Size Code: 1 = 495mm x 695mm, 2 = 495mm x 572mm, 3 = 495mm x 622mm.
- Upflow Filter Size Code: 1 = 775mm x 460mm, 2 = 775mm x 448mm, 3 = 775mm x 498 & 4 = 775mm x 590mm.
- All filters are 100mm thick and have an efficiency rating of G5 in accordance with EU Standard EN779.
- Water feed electrical conductivity for the humidifier should be in the range of 400-800 micro siemens.
- For Drycooler connection inlet/outlet sizes for Duplex or Twin Circuit Units, refer to Drycooler Drawing or factory.

8. For correct installation pipe sizes refer to Refrigerant & Water pipe sizing tables.

ELECTRICAL DETAILS

400V/3PH/50Hz

Air Cooled Models

Model	10	15	20	25	30	35	40
Controls FLA	1.0	1.0	1.0	1.0	1.0	1.0	1.0
Fans FLA	2.1	2.7	3.6	4.9	4.9	6.4	8.3
Reheat FLA	13.9	13.9	13.9	21.7	21.7	21.7	21.7
Humidifier FLA	3.2	3.2	3.2	3.2	8.4	8.4	8.4
Scroll Compressor FLA	6.2	8.3	12.0	12.9	16.3	19.0	24.9
Condenser FLA @ 30°C	2.4	2.4	3.6	3.0	6.0	6.0	6.0
Condenser FLA @ 35°C	2.4	2.4	3.6	3.6	6.0	6.0	6.0
Condenser FLA @ 40°C	2.4	3.0	6.0	6.0	6.0	9.0	9.0
Condenser FLA @ 45°C	3.0	6.0	6.0	9.0	9.0	12.0	12.0
Model	10/10	15/15	20/20	25/25	30/30	35/35	40/40
Controls FLA	1.0	1.0	1.0	1.0	1.0	1.0	1.0
Fans FLA	4.2	5.4	7.2	9.8	9.8	12.8	16.6
Reheat FLA	13.9	13.9	13.9	21.7	21.7	21.7	35.9
Humidifier FLA	3.2	3.2	8.4	8.4	8.4	8.4	8.4
Scroll Compressor FLA	12.4	16.6	24.0	25.8	32.6	38.0	49.8
Condenser FLA @ 30°C	4.8	4.8	7.2	6.0	12.0	12.0	12.0
Condenser FLA @ 35°C	4.8	4.8	7.2	7.2	12.0	12.0	12.0
Condenser FLA @ 40°C	4.8	6.0	12.0	12.0	12.0	18.0	18.0
Condenser FLA @ 45°C	6.0	12.0	12.0	18.0	18.0	24.0	24.0

Water Cooled Models

Model	10	15	20	25	30	35	40
Controls FLA	1.0	1.0	1.0	1.0	1.0	1.0	1.0
Fans FLA	2.1	2.7	3.6	4.9	4.9	6.4	8.3
Reheat FLA	13.9	13.9	13.9	21.7	21.7	21.7	21.7
Humidifier FLA	3.2	3.2	3.2	3.2	8.4	8.4	8.4
Scroll Compressor FLA	6.2	8.3	12.0	12.9	16.3	19.0	24.9
Model	10/10	15/15	20/20	25/25	30/30	35/35	40/40
Controls FLA	1.0	1.0	1.0	1.0	1.0	1.0	1.0
Fans FLA	4.2	5.4	7.2	9.8	9.8	12.8	16.6
Reheat FLA	13.9	13.9	13.9	21.7	21.7	21.7	35.9
Humidifier FLA	3.2	3.2	8.4	8.4	8.4	8.4	8.4
Scroll Compressor FLA	12.4	16.6	24.0	25.8	32.6	38.0	49.8

Notes:

1. FLA = Full Load Amps.
2. Unit maximum FLA is the total of the components, which operate during maximum electrical load conditions. For full function units with humidifier & electric reheat the maximum FLA would be in dehumidification mode i.e. cooling + reheat.
3. In dehumidification in Duplex or Twin Circuit Units, calculate the max FLA based on single module compressor FLA as only one compressor operates in dehumidification mode.
4. For Air Cooled Units, the condenser fan FLA for AGS 401 – 403 is based on all fans being single phase while for AGS 501 – 503 the FLA is based on the first fan being 1 phase (for pressure activated fan speed control) with the remaining fans being 3 phase (pressure switch activated).
5. For Glycol Cooled Units with Drycoolers, please note that Drycooler Fans are all 3 phase on/off. Head pressure control is carried out by a water regulating valve in the indoor unit.

400V/3PH/50Hz

Glycol / ECX Cooled Models

Model	10	15	20	25	30	35	40
Controls FLA	1.0	1.0	1.0	1.0	1.0	1.0	1.0
Fans FLA	2.1	2.7	3.6	4.9	4.9	6.4	8.3
Reheat FLA	13.9	13.9	13.9	21.7	21.7	21.7	21.7
Humidifier FLA	3.2	3.2	3.2	3.2	8.4	8.4	8.4
Scroll Compressor FLA	6.2	8.3	12.0	12.9	16.3	19.0	24.9
Drycooler FLA @ 30°C	1.4	1.4	1.4	2.8	2.8	2.8	2.8
Drycooler FLA @ 35°C	1.4	2.8	2.8	2.8	4.2	4.2	4.2
Drycooler FLA @ 40°C	1.4	2.8	2.8	2.8	4.2	4.2	4.2
Drycooler FLA @ 45°C	2.8	2.8	4.2	4.2	5.6	5.6	5.6
Model	10/10	15/15	20/20	25/25	30/30	35/35	40/40
Controls FLA	1.0	1.0	1.0	1.0	1.0	1.0	1.0
Fans FLA	4.2	5.4	7.2	9.8	9.8	12.8	16.6
Reheat FLA	13.9	13.9	13.9	21.7	21.7	21.7	35.9
Humidifier FLA	3.2	3.2	8.4	8.4	8.4	8.4	8.4
Scroll Compressor FLA	12.4	16.6	24.0	25.8	32.6	38.0	49.8
Drycooler FLA @ 30°C	1.4	2.8	2.8	4.2	4.2	5.6	5.6
Drycooler FLA @ 35°C	2.8	4.2	4.2	5.6	9.9	9.9	12.4
Drycooler FLA @ 40°C	2.8	4.2	4.2	5.6	9.9	9.9	12.4
Drycooler FLA @ 45°C	4.2	5.6	5.6	9.9	12.4	12.4	14.9

Chilled Water Models

Model	10	15	20	25	30	35	40
Controls FLA	1.0	1.0	1.0	1.0	1.0	1.0	1.0
Fans FLA	2.1	2.7	3.6	4.9	4.9	6.4	8.3
Reheat FLA	13.9	13.9	13.9	21.7	21.7	21.7	21.7
Humidifier FLA	3.2	3.2	3.2	3.2	8.4	8.4	8.4
Model	10/10	15/15	20/20	25/25	30/30	35/35	40/40
Controls FLA	1.0	1.0	1.0	1.0	1.0	1.0	1.0
Fans FLA	4.2	5.4	7.2	9.8	9.8	12.8	16.6
Reheat FLA	13.9	13.9	13.9	21.7	21.7	21.7	35.9
Humidifier FLA	3.2	3.2	8.4	8.4	8.4	8.4	8.4

- Notes:**
1. FLA = Full Load Amps.
 2. Unit maximum FLA is the total of the components, which operate during maximum electrical load conditions. For full function units with humidifier & electric reheat the maximum FLA would be in dehumidification mode i.e. cooling + reheat.
 3. In dehumidification in Duplex or Twin Circuit Units, calculate the max FLA based on single module compressor FLA as only one compressor operates in dehumidification mode.
 4. For Air Cooled Units, the condenser fan FLA for AGS 401 – 403 is based on all fans being single phase while for AGS 501 – 503 the FLA is based on the first fan being 1 phase (for pressure activated fan speed control) with the remaining fans being 3 phase (pressure switch activated).
 5. For Glycol Cooled Units with Drycoolers, please note that Drycooler Fans are all 3 phase on/off. Head pressure control is carried out by a water regulating valve in the indoor unit.

220V/3PH/60Hz

Air Cooled Models

Model	10	15	20	25	30	35	40
Controls FLA	1.0	1.0	1.0	1.0	1.0	1.0	1.0
Fans FLA	3.8	4.9	6.6	8.9	8.9	11.6	15.1
Reheat FLA	25.3	25.3	25.3	39.5	39.5	39.5	39.5
Humidifier FLA	5.8	5.8	5.8	5.8	15.3	15.3	15.3
Scroll Compressor FLA	10.0	14.6	20.2	24.0	25.8	32.6	38.0
Condenser FLA @ 30°C	2.8	2.8	4.2	3.9	7.8	7.8	7.8
Condenser FLA @ 35°C	2.8	2.8	4.2	4.2	7.8	7.8	7.8
Condenser FLA @ 40°C	2.8	3.9	7.8	7.8	7.8	11.7	11.7
Condenser FLA @ 45°C	3.9	7.8	7.8	11.7	11.7	15.6	15.6
Model	10/10	15/15	20/20	25/25	30/30	35/35	40/40
Controls FLA	1.0	1.0	1.0	1.0	1.0	1.0	1.0
Fans FLA	7.6	9.8	13.2	17.8	17.8	23.2	30.2
Reheat FLA	25.3	25.3	25.3	39.5	39.5	39.5	65.3
Humidifier FLA	5.8	5.8	15.3	15.3	15.3	15.3	15.3
Scroll Compressor FLA	20.0	29.2	40.4	48.0	51.6	65.2	78.0
Condenser FLA @ 30°C	5.6	5.6	8.4	7.8	15.6	15.6	15.6
Condenser FLA @ 35°C	5.6	5.6	8.4	8.4	15.6	15.6	15.6
Condenser FLA @ 40°C	5.6	7.8	15.6	15.6	15.6	23.4	23.4
Condenser FLA @ 45°C	7.8	15.6	15.6	23.4	23.4	31.2	31.2

Water Cooled Models

Model	10	15	20	25	30	35	40
Controls FLA	1.0	1.0	1.0	1.0	1.0	1.0	1.0
Fans FLA	3.8	4.9	6.6	8.9	8.9	11.6	15.1
Reheat FLA	25.3	25.3	25.3	39.5	39.5	39.5	39.5
Humidifier FLA	5.8	5.8	5.8	5.8	15.3	15.3	15.3
Scroll Compressor FLA	10.0	14.6	20.2	24.0	25.8	32.6	38.0
Model	10/10	15/15	20/20	25/25	30/30	35/35	40/40
Controls FLA	1.0	1.0	1.0	1.0	1.0	1.0	1.0
Fans FLA	7.6	9.8	13.2	17.8	17.8	23.2	30.2
Reheat FLA	25.3	25.3	25.3	39.5	39.5	39.5	65.3
Humidifier FLA	5.8	5.8	15.3	15.3	15.3	15.3	15.3
Scroll Compressor FLA	20.0	29.2	40.4	48.0	51.6	65.2	78.0

- Notes:**
1. FLA = Full Load Amps.
 2. Unit maximum FLA is the total of the components, which operate during maximum electrical load conditions. For full function units with humidifier & electric reheat the maximum FLA would be in dehumidification mode i.e. cooling + reheat.
 3. In dehumidification in Duplex or Twin Circuit Units, calculate the max FLA based on single module compressor FLA as only one compressor operates in dehumidification mode.
 4. For Air Cooled Units, the condenser fan FLA for AGS 401 – 403 is based on all fans being single phase while for AGS 501 – 503 the FLA is based on the first fan being 1 phase (for pressure activated fan speed control) with the remaining fans being 3 phase (pressure switch activated).
 5. For Glycol Cooled Units with Drycoolers, please note that Drycooler Fans are all 3 phase on/off. Head pressure control is carried out by a water regulating valve in the indoor unit.

Glycol / ECX Cooled Models

Model	10	15	20	25	30	35	40
Controls FLA	1.0	1.0	1.0	1.0	1.0	1.0	1.0
Fans FLA	3.8	4.9	6.6	8.9	8.9	11.6	15.1
Reheat FLA	25.3	25.3	25.3	39.5	39.5	39.5	39.5
Humidifier FLA	5.8	5.8	5.8	5.8	15.3	15.3	15.3
Scroll Compressor FLA	10.0	14.6	20.2	24.0	25.8	32.6	38.0
Drycooler FLA @ 30°C	3.9	3.9	3.9	7.8	7.8	7.8	7.8
Drycooler FLA @ 35°C	3.9	7.8	7.8	7.8	11.7	11.7	11.7
Drycooler FLA @ 40°C	3.9	7.8	7.8	7.8	11.7	11.7	11.7
Drycooler FLA @ 45°C	7.8	11.7	11.7	11.7	15.6	15.6	15.6
Model	10/10	15/15	20/20	25/25	30/30	35/35	40/40
Controls FLA	1.0	1.0	1.0	1.0	1.0	1.0	1.0
Fans FLA	7.6	9.8	13.2	17.8	17.8	23.2	30.2
Reheat FLA	25.3	25.3	25.3	39.5	39.5	39.5	65.3
Humidifier FLA	5.8	5.8	15.3	15.3	15.3	15.3	15.3
Scroll Compressor FLA	20.0	29.2	40.4	48.0	51.6	65.2	78.0
Drycooler FLA @ 30°C	3.9	7.8	7.8	11.7	11.7	15.6	15.6
Drycooler FLA @ 35°C	7.8	11.7	11.7	15.6	18.4	18.4	23.0
Drycooler FLA @ 40°C	7.8	11.7	11.7	15.6	18.4	18.4	23.0
Drycooler FLA @ 45°C	11.7	15.6	15.6	18.4	18.4	23.0	27.6

Chilled Water Models

Model	10	15	20	25	30	35	40
Controls FLA	1.0	1.0	1.0	1.0	1.0	1.0	1.0
Fans FLA	3.8	4.9	6.6	8.9	8.9	11.6	15.1
Reheat FLA	25.3	25.3	25.3	39.5	39.5	39.5	39.5
Humidifier FLA	5.8	5.8	5.8	5.8	15.3	15.3	15.3
Model	10/10	15/15	20/20	25/25	30/30	35/35	40/40
Controls FLA	1.0	1.0	1.0	1.0	1.0	1.0	1.0
Fans FLA	7.6	9.8	13.2	17.8	17.8	23.2	30.2
Reheat FLA	25.3	25.3	25.3	39.5	39.5	39.5	65.3
Humidifier FLA	5.8	5.8	15.3	15.3	15.3	15.3	15.3

- Notes:**
1. FLA = Full Load Amps.
 2. Unit maximum FLA is the total of the components, which operate during maximum electrical load conditions. For full function units with humidifier & electric reheat the maximum FLA would be in dehumidification mode i.e. cooling + reheat.
 3. In dehumidification in Duplex or Twin Circuit Units, calculate the max FLA based on single module compressor FLA as only one compressor operates in dehumidification mode.
 4. For Air Cooled Units, the condenser fan FLA for AGS 401 – 403 is based on all fans being single phase while for AGS 501 – 503 the FLA is based on the first fan being 1 phase (for pressure activated fan speed control) with the remaining fans being 3 phase (pressure switch activated).
 5. For Glycol Cooled Units with Drycoolers, please note that Drycooler Fans are all 3 phase on/off. Head pressure control is carried out by a water regulating valve in the indoor unit.

Air Cooled Models

Model	10	15	20	25	30	35	40
Controls FLA	1.0	1.0	1.0	1.0	1.0	1.0	1.0
Fans FLA	2.2	2.9	3.8	5.2	5.2	6.8	8.8
Reheat FLA	13.2	13.2	13.2	20.6	20.6	20.6	20.6
Humidifier FLA	3.4	3.4	3.4	3.4	8.9	8.9	8.9
Scroll Compressor FLA	5.0	7.3	10.1	12.0	12.9	16.3	19.0
Condenser FLA @ 30°C	1.2	1.2	1.8	1.6	3.2	3.2	3.2
Condenser FLA @ 35°C	1.2	1.2	1.8	1.8	3.2	3.2	3.2
Condenser FLA @ 40°C	1.2	1.6	3.2	3.2	3.2	4.8	4.8
Condenser FLA @ 45°C	1.6	3.2	3.2	4.8	4.8	5.6	5.6
Model	10/10	15/15	20/20	25/25	30/30	35/35	40/40
Controls FLA	1.0	1.0	1.0	1.0	1.0	1.0	1.0
Fans FLA	4.4	5.8	7.6	10.4	10.4	13.6	17.6
Reheat FLA	13.2	13.2	13.2	20.6	20.6	20.6	34.2
Humidifier FLA	3.4	3.4	8.9	8.9	8.9	8.9	8.9
Scroll Compressor FLA	10.0	14.6	20.2	24.0	25.8	32.6	38.0
Condenser FLA @ 30°C	2.4	2.4	3.6	3.2	6.4	6.4	6.4
Condenser FLA @ 35°C	2.4	2.4	3.6	3.6	6.4	6.4	6.4
Condenser FLA @ 40°C	2.4	3.2	6.4	6.4	6.4	9.6	9.6
Condenser FLA @ 45°C	3.2	6.4	6.4	9.6	9.6	11.2	11.2

Water Cooled Models

Model	10	15	20	25	30	35	40
Controls FLA	1.0	1.0	1.0	1.0	1.0	1.0	1.0
Fans FLA	2.2	2.9	3.8	5.2	5.2	6.8	8.8
Reheat FLA	13.2	13.2	13.2	20.6	20.6	20.6	20.6
Humidifier FLA	3.4	3.4	3.4	3.4	8.9	8.9	8.9
Scroll Compressor FLA	5.0	7.3	10.1	12.0	12.9	16.3	19.0
Model	10/10	15/15	20/20	25/25	30/30	35/35	40/40
Controls FLA	1.0	1.0	1.0	1.0	1.0	1.0	1.0
Fans FLA	4.4	5.8	7.6	10.4	10.4	13.6	17.6
Reheat FLA	13.2	13.2	13.2	20.6	20.6	20.6	34.2
Humidifier FLA	3.4	3.4	8.9	8.9	8.9	8.9	8.9
Scroll Compressor FLA	10.0	14.6	20.2	24.0	25.8	32.6	38.0

Notes:

1. FLA = Full Load Amps.
2. Unit maximum FLA is the total of the components, which operate during maximum electrical load conditions. For full function units with humidifier & electric reheat the maximum FLA would be in dehumidification mode i.e. cooling + reheat.
3. In dehumidification in Duplex or Twin Circuit Units, calculate the max FLA based on single module compressor FLA as only one compressor operates in dehumidification mode.
4. For Air Cooled Units, the condenser fan FLA for AGS 401 – 403 is based on all fans being single phase while for AGS 501 – 503 the FLA is based on the first fan being 1 phase (for pressure activated fan speed control) with the remaining fans being 3 phase (pressure switch activated).
5. For Glycol Cooled Units with Drycoolers, please note that Drycooler Fans are all 3 phase on/off. Head pressure control is carried out by a water regulating valve in the indoor unit.

380V/3PH/60Hz

Glycol / ECX Cooled Models

Model	10	15	20	25	30	35	40
Controls FLA	1.0	1.0	1.0	1.0	1.0	1.0	1.0
Fans FLA	2.2	2.9	3.8	5.2	5.2	6.8	8.8
Reheat FLA	13.2	13.2	13.2	20.6	20.6	20.6	20.6
Humidifier FLA	3.4	3.4	3.4	3.4	8.9	8.9	8.9
Scroll Compressor FLA	5.0	7.3	10.1	12.0	12.9	16.3	19.0
Drycooler FLA @ 30°C	1.6	1.6	1.6	3.2	3.2	3.2	3.2
Drycooler FLA @ 35°C	1.6	3.2	3.2	3.2	4.8	4.8	4.8
Drycooler FLA @ 40°C	1.6	3.2	3.2	3.2	4.8	4.8	4.8
Drycooler FLA @ 45°C	3.2	3.2	4.8	4.8	6.4	6.4	6.4
Model	10/10	15/15	20/20	25/25	30/30	35/35	40/40
Controls FLA	1.0	1.0	1.0	1.0	1.0	1.0	1.0
Fans FLA	4.4	5.8	7.6	10.4	10.4	13.6	17.6
Reheat FLA	13.2	13.2	13.2	20.6	20.6	20.6	34.2
Humidifier FLA	3.4	3.4	8.9	8.9	8.9	8.9	8.9
Scroll Compressor FLA	10.0	14.6	20.2	24.0	25.8	32.6	38.0
Drycooler FLA @ 30°C	1.6	3.2	3.2	4.8	4.8	6.4	6.4
Drycooler FLA @ 35°C	3.2	4.8	4.8	6.4	13.6	13.6	17.0
Drycooler FLA @ 40°C	3.2	4.8	4.8	6.4	13.6	13.6	17.0
Drycooler FLA @ 45°C	4.8	6.4	6.4	13.6	17.0	17.0	20.4

Chilled Water Models

Model	10	15	20	25	30	35	40
Controls FLA	1.0	1.0	1.0	1.0	1.0	1.0	1.0
Fans FLA	2.2	2.9	3.8	5.2	5.2	6.8	8.8
Reheat FLA	13.2	13.2	13.2	20.6	20.6	20.6	20.6
Humidifier FLA	3.4	3.4	3.4	3.4	8.9	8.9	8.9
Model	10/10	15/15	20/20	25/25	30/30	35/35	40/40
Controls FLA	1.0	1.0	1.0	1.0	1.0	1.0	1.0
Fans FLA	4.4	5.8	7.6	10.4	10.4	13.6	17.6
Reheat FLA	13.2	13.2	13.2	20.6	20.6	20.6	34.2
Humidifier FLA	3.4	3.4	8.9	8.9	8.9	8.9	8.9

- Notes:**
1. FLA = Full Load Amps.
 2. Unit maximum FLA is the total of the components, which operate during maximum electrical load conditions. For full function units with humidifier & electric reheat the maximum FLA would be in dehumidification mode i.e. cooling + reheat.
 3. In dehumidification in Duplex or Twin Circuit Units, calculate the max FLA based on single module compressor FLA as only one compressor operates in dehumidification mode.
 4. For Air Cooled Units, the condenser fan FLA for AGS 401 – 403 is based on all fans being single phase while for AGS 501 – 503 the FLA is based on the first fan being 1 phase (for pressure activated fan speed control) with the remaining fans being 3 phase (pressure switch activated).
 5. For glycol Cooled Units with drycoolers, please note that drycooler fans are all 3 phase on/off. Head pressure control is carried out by a water regulating valve in the indoor unit.

Air Cooled Models

Model	10	15	20	25	30	35	40
Controls FLA	1.0	1.0	1.0	1.0	1.0	1.0	1.0
Fans FLA	1.8	2.3	3.1	4.3	4.3	5.6	7.2
Reheat FLA	16.1	16.1	16.1	25.1	25.1	25.1	25.1
Humidifier FLA	2.8	2.8	2.8	2.8	7.3	7.3	7.3
Scroll Compressor FLA	6.0	8.8	12.1	14.4	15.5	19.6	22.8
Condenser FLA @ 30°C	1.6	1.6	2.4	1.0	2.0	2.0	2.0
Condenser FLA @ 35°C	1.6	1.6	2.4	2.4	2.0	2.0	2.0
Condenser FLA @ 40°C	1.6	1.0	2.0	2.0	2.0	3.0	3.0
Condenser FLA @ 45°C	1.0	2.0	2.0	3.0	3.0	4.0	4.0
Model	10/10	15/15	20/20	25/25	30/30	35/35	40/40
Controls FLA	1.0	1.0	1.0	1.0	1.0	1.0	1.0
Fans FLA	3.6	4.6	6.2	8.6	8.6	11.2	14.4
Reheat FLA	16.1	16.1	16.1	25.1	25.1	25.1	41.3
Humidifier FLA	2.8	2.8	7.3	7.3	7.3	7.3	7.3
Scroll Compressor FLA	12.0	17.6	24.2	28.8	31.0	39.2	45.6
Condenser FLA @ 30°C	3.2	3.2	4.8	2.0	4.0	4.0	4.0
Condenser FLA @ 35°C	3.2	3.2	4.8	4.8	4.0	4.0	4.0
Condenser FLA @ 40°C	3.2	2.0	4.0	4.0	4.0	6.0	6.0
Condenser FLA @ 45°C	2.0	4.0	4.0	6.0	6.0	8.0	8.0

Water Cooled Models

Model	10	15	20	25	30	35	40
Controls FLA	1.0	1.0	1.0	1.0	1.0	1.0	1.0
Fans FLA	1.8	2.3	3.1	4.3	4.3	5.6	7.2
Reheat FLA	16.1	16.1	16.1	25.1	25.1	25.1	25.1
Humidifier FLA	2.8	2.8	2.8	2.8	7.3	7.3	7.3
Scroll Compressor FLA	6.0	8.8	12.1	14.4	15.5	19.6	22.8
Model	10/10	15/15	20/20	25/25	30/30	35/35	40/40
Controls FLA	1.0	1.0	1.0	1.0	1.0	1.0	1.0
Fans FLA	3.6	4.6	6.2	8.6	8.6	11.2	14.4
Reheat FLA	16.1	16.1	16.1	25.1	25.1	25.1	41.3
Humidifier FLA	2.8	2.8	7.3	7.3	7.3	7.3	7.3
Scroll Compressor FLA	12.0	17.6	24.2	28.8	31.0	39.2	45.6

- Notes:**
1. FLA = Full Load Amps.
 2. Unit maximum FLA is the total of the components, which operate during maximum electrical load conditions. For full function units with humidifier & electric reheat the maximum FLA would be in dehumidification mode i.e. cooling + reheat.
 3. In dehumidification in Duplex or Twin Circuit Units, calculate the max FLA based on single module compressor FLA as only one compressor operates in dehumidification mode.
 4. For Air Cooled Units, the condenser fan FLA for AGS 401 – 403 is based on all fans being single phase while for AGS 501 – 503 the FLA is based on the first fan being 1 phase (for pressure activated fan speed control) with the remaining fans being 3 phase (pressure switch activated).
 5. For Glycol Cooled Units with Drycoolers, please note that Drycooler Fans are all 3 phase on/off. Head pressure control is carried out by a water regulating valve in the indoor units.

Glycol / ECX Cooled Models

Model	10	15	20	25	30	35	40
Controls FLA	1.0	1.0	1.0	1.0	1.0	1.0	1.0
Fans FLA	1.8	2.3	3.1	4.3	4.3	5.6	7.2
Reheat FLA	16.1	16.1	16.1	25.1	25.1	25.1	25.1
Humidifier FLA	2.8	2.8	2.8	2.8	7.3	7.3	7.3
Scroll Compressor FLA	6.0	8.8	12.1	14.4	15.5	19.6	22.8
Drycooler FLA @ 30°C	1.0	1.0	1.0	1.0	2.0	2.0	2.0
Drycooler FLA @ 35°C	1.0	2.0	2.0	2.0	3.0	3.0	3.0
Drycooler FLA @ 40°C	1.0	2.0	2.0	2.0	3.0	3.0	3.0
Drycooler FLA @ 45°C	2.0	2.0	3.0	3.0	4.0	4.0	4.0
Model	10/10	15/15	20/20	25/25	30/30	35/35	40/40
Controls FLA	1.0	1.0	1.0	1.0	1.0	1.0	1.0
Fans FLA	3.6	4.6	6.2	8.6	8.6	11.2	14.4
Reheat FLA	16.1	16.1	16.1	25.1	25.1	25.1	41.3
Humidifier FLA	2.8	2.8	7.3	7.3	7.3	7.3	7.3
Scroll Compressor FLA	12.0	17.6	24.2	28.8	31.0	39.2	45.6
Drycooler FLA @ 30°C	1.0	2.0	2.0	3.0	3.0	4.0	4.0
Drycooler FLA @ 35°C	2.0	3.0	3.0	4.0	11.2	11.2	14.0
Drycooler FLA @ 40°C	2.0	3.0	3.0	4.0	11.2	11.2	14.0
Drycooler FLA @ 45°C	3.0	4.0	4.0	11.2	14.0	14.0	16.8

Chilled Water Models

Model	10	15	20	25	30	35	40
Controls FLA	1.0	1.0	1.0	1.0	1.0	1.0	1.0
Fans FLA	1.8	2.3	3.1	4.3	4.3	5.6	7.2
Reheat FLA	16.1	16.1	16.1	25.1	25.1	25.1	25.1
Humidifier FLA	2.8	2.8	2.8	2.8	7.3	7.3	7.3
Model	10/10	15/15	20/20	25/25	30/30	35/35	40/40
Controls FLA	1.0	1.0	1.0	1.0	1.0	1.0	1.0
Fans FLA	3.6	4.6	6.2	8.6	8.6	11.2	14.4
Reheat FLA	16.1	16.1	16.1	25.1	25.1	25.1	41.3
Humidifier FLA	2.8	2.8	7.3	7.3	7.3	7.3	7.3

- Notes:**
1. FLA = Full Load Amps.
 2. Unit maximum FLA is the total of the components, which operate during maximum electrical load conditions. For full function units with humidifier & electric reheat the maximum FLA would be in dehumidification mode i.e. cooling + reheat.
 3. In dehumidification in Duplex or Twin Circuit Units, calculate the max FLA based on single module compressor FLA as only one compressor operates in dehumidification mode.
 4. For Air Cooled Units, the condenser fan FLA for AGS 401 – 403 is based on all fans being single phase while for AGS 501 – 503 the FLA is based on the first fan being 1 phase (for pressure activated fan speed control) with the remaining fans being 3 phase (pressure switch activated).
 5. For Glycol Cooled Units with Drycoolers, please note that Drycooler Fans are all 3 phase on/off. Head pressure control is carried out by a water regulating valve in the indoor unit.

OPERATION

GENERAL

MICROPROCESSOR CONTROLS

All Units shall be fitted as standard with the latest Delta range of DIN rail mounted Microprocessor Controls. The Control System utilises a main Microprocessor Interface Board equipped with a set of terminals necessary to connect the Board to the controlled devices. All software is permanently stored in flash RAM and is therefore protected even in the event of a power failure. Unit software is uploaded to the Microprocessor using a RAM key. On multi unit sites, this quickens unit commissioning. The software can also easily be changed or upgraded on site by qualified service personnel.

Note:

For more detailed information refer to Detailed Controls Manuals.

GENERAL SYSTEM OPERATION

Unit operation is completely automatic. The sequence below explains how the unit operates:

- The air, drawn in by the fan(s), enters the unit through top of the unit or the inlet grille.
- The air is immediately filtered.
- The temperature & relative humidity sensor verifies the condition of the inlet air and relays this to the microprocessor controller.
- The controller compares this information to the set point and proportional band values programmed into its memory. it then commands the air conditioner to treat the air as follows

CUSTOMER CONNECTIONS

Power cables to the load break switch should be sized in compliance with local codes (see electrical data for permissible fuse size). Power cables required are 3 phase and a neutral (2.5mm minimum size neutral) and appropriately sized ground. The ground connection is vital. External device power / control connections to the control section are as follows:

- a) Connections to the dry cooler.
- b) Connection to the remote shutdown feature is via terminals 15 & 16. Normally Closed N/C Unit On, Normally Open N/O Unit Off by Remote. A relay is required for this option.
- c) Connections for the external alarm relay's are via terminals 18, 19 & 20, (250 VAC rated - 10 Amps). Volt Free Contacts.
- d) Externally required A.C. voltage supplies are not to be taken from the unit, interface relays are to be utilised for these applications.

INITIAL START UP

- a) On initial start-up, the crankcase heaters must be energised for 3 hours before starting the compressor. Do not engage the 'On/Off' button on the keypad or run the compressor through the 'Service Access' level during this period. The controller will display the following message:

**SYSTEM BOOT
PLEASE WAIT**

- b) After a 5 second delay the controller will display the following:

13:58	12/02/97	MOI
Temperature:	23.4 deg.C	
Humidity:	37.7 RH%	
UNIT ON		

NOTE: To prevent possible damage to the compressor, power to the unit should be on whenever possible.

- c) The unit is now ready for operation.

AIRFLOW OPERATION

a) When the electrical power has been energised for at least 3 hours, the unit may be energised by pressing the **"On/Off"** key on the keypad. The fan contactor KM1 (& KM2- Duplex/Twin Circuit/Twin Circuit) will energise establishing airflow.

POWER FAILURE, INTERRUPTION OF SYSTEM RESET

- a) Should a 'brownout' (where voltage is low enough to cause the electronics to fail) or electrical power failure occur, the controller will be alerted as the voltage begins to drop. It will then de-energise all contactors. During power failure all data entered through the keypad will be held in a memory back-up which is supported by an EPROM. The EPROM will retain data indefinitely without external power.
- b) If a unit is in the "RUN" mode when a power failure occurs, then, upon power restoration the unit will automatically commence "RUN" operation. The settle timer will count down to zero and at zero the unit will then continue as outlined in the **Airflow, Temperature Control and Humidity Control** sections.

EC FAN OPERATION

GENERAL

The EC plug fan is a backward curved fan with an integrated EC electrically commutated motor which is controlled directly from the microprocessor using a 0-10V output. Options on setup are:

- Strategy 1: Fixed speed
- Strategy 2: Track temperature band
- Strategy 3: Maintain pressure setpoint
- Strategy 4: Control from BMS
- Strategy 5: Maintain airflow setpoint
- Dehumidification control mode

FIXED SPEED

A fixed 0-10V signal is set through the user display to operate the fan at a constant speed.

TRACK TEMPERATURE BAND

The unit is set up to track the heating and cooling bands with set voltage limits. Max voltage / fan air volume is at set point plus control band & min voltage / fan air volume at set point

Max voltage / air volume is typically design air volume and min air volume is typically around 60% for chilled water units. Minimum value needs to insure that there are no hot spots due to lack of airflow and that there is no loss of sensible cooling capacity to latent cooling capacity at the cooling coil.

MAINTAIN PRESSURE SETPOINT

The microprocessor reads the underfloor pressure via a pressure transducer. The fan speed is then controlled to maintain a fixed underfloor pressure at all times. Pressure setpoint and min & max voltages are input through the user display. A reading of the underfloor pressure can also be viewed.

CONTROL FROM BMS

The speed of the fan can be controlled directly from a BMS if one of the optional BMS interface cards are installed in the unit. The BMS writes a value of between 0 & 100.0% to an analog BMS address. The fan then operates to this speed. Min and max voltage can be input through the user display to insure the fan operates within acceptable limits.

MAINTAIN AIRFLOW SETPOINT

The microprocessor calculates the airflow through the unit with the use of a pressure transducer and a special inlet ring across one of the fans designed for measuring airflow. PID control is then utilized to control the speed of the fans to insure a steady supply air volume. Airflow setpoint and min & max voltages are input through the user display. A reading of the total airflow through the unit can also be viewed.

DEHUMIDIFICATION CONTROL MODE

Unit set up to give a reduced fan air volume in dehumidification mode to conserve energy in dehumidification while quickly achieving the dehumidification effect at the cooling coil. This output voltage is again user selectable.

HEATING OPERATION

GENERAL

This can take one of two forms:

- Electrical heating: The electric elements heat the air passing over them. Heating is supplied by 3 elements configured to support 2 stages of heating. Airflow has to be established before the elements are energised. The heaters are protected by a manual reset thermostats. This thermostat is a capillary type stat positioned across the coil near the elements.
- Hot Water Heating (optional): If hot water is available this flows through the hot water coil thus heating the air passing over it. The hot water flow is controlled by an on-off (2 or 3-way) valve.

On a Duplex/Twin Circuit unit the heating operation is carried out in the master module only.

ELECTRIC HEATING

CAUTION: When commissioning the heater stage, be aware that the electric heater elements may at first give off smoke and may cause smoke detectors on site to alarm, e.g. Halon System.

When the supply airflow is established, a drop in return air temperature below the return air setpoint (default 22.0 Deg. C) will cause the controller to call for Heating Stage 1. The contactor KM6 will energise.

If the return air temperature falls (default 1.0 Deg. C) below the return air setpoint, the controller will call for Heating Stage 2. The contactor KM7 will energise.

A rise in return air temperature below the return air temperature setpoint will cancel heating stage 2. Contactor KM7 will de-energise.

As the return air temperature rises still further, Heating Stage 1 will be cancelled above the return air temperature setpoint, contactor KM6 will de-energise.

ELECTRIC HEATER PROTECTION & ALARMS

- a) The electric heaters are protected by one high temperature stats (RS1) which is fitted in the heater termination box.
- b) RS1 is a capillary type temperature stat. This capillary wrapped around the electric heater elements. If the temperature of the heater elements rises above 145 Deg. C the stat contacts will open and electric heating will be terminated.
- c) When the return air temperature drops sufficiently RS1 can be manually reset. Electric heating will continue as normal.

HOT WATER REHEAT

- a) Hot Water Heating occurs when the return air temperature falls below the return air temperature setpoint. The solenoid valve or modulating valve will energise.
- b) As the return air temperature rises above the return air setpoint the controller will cancel the heating process by de-energising the solenoid valve or modulating valve.

Note: Heating can occur when compressor 1 is operating in the dehumidification mode and the return air temperature is below the return air temperature setpoint by the appropriate amount.

COOLING OPERATION

COOLING FOR WATER COOLED UNITS

When cooling is required the compressor contactor is energised. Head pressure is maintained by the water regulating valve. On a Duplex/Twin Circuit unit either compressor can be activated as the first stage but whichever compressor is called on first is also the first to be de-energised as room requirements are met.

DUPLEX/TWIN CIRCUIT CONTROL

On Water Cooled Duplex/Twin Circuit units a single set of controls activates the fans and cooling in both circuits. Cooling is met by both master and slave units. On Water Cooled Duplex/Twin Circuit units either or both compressors may be called on to provide cooling capacity, whichever compressor is called on first will also be first to be de-activated as room temperature falls, wear equalisation is therefore achieved. A loss of airflow on the master unit will prompt the slave unit into an automatic cooling mode.

SINGLE CIRCUIT COOLING

- a) Mechanical cooling can only occur when airflow has been established.
- b) When the return air temperature rises above the return air temperature setpoint (default 22.0 Deg. C) the controller will activate the cooling process. Compressor 1 (KM3) will energise.
- c) When the return air temperature decreases above the return air temperature setpoint the controller will cancel the cooling stage. Contactor (KM3) will de-energise.

DUPLEX/TWIN CIRCUIT COOLING

- a) Mechanical cooling can only occur when airflow has been established
- b) When the return air temperature rises above the return air temperature setpoint (default 22.0 Deg. C) the controller will activate the cooling process. Either compressor (KM3 or KM4) will energise as the refrigeration circuits work on an auto rotating, lead/lag compressor basis. Compressor 1 (KM3) will energise.
- c) If the return air temperature rises further above the return air temperature setpoint the controller will activate the second stage of cooling. The other Compressor 2 (KM3 or KM4) will energise.
- d) If the return air temperature decreases above the return air temperature setpoint the controller will revert to one stage of cooling. The refrigeration circuit which began cooling initially will de-energise.
- e) If the return air temperature decreases further above the return air temperature setpoint the controller will cause the second compressor to de-energise.

COMPRESSOR PROTECTION

All compressors are protected by low and high pressure switches. The high and low pressure stats HP1 and LP1 are monitored from commencement of the cooling process. Should a high or low pressure alarm be detected by the controller, the affected cooling stage will be de-energised. The other cooling stage (Duplex/Twin Circuit) will be energised if not already energised.

DEHUMIDIFICATION

Dehumidification is provided by the cooling mode of the unit. In air, water or glycol cooled units the compressor provides the dehumidification operation. On chilled water units dehumidification is provided by having the modulating valve fully open. On Duplex/Twin Circuit models dehumidification is handled by the master module.

Dehumidification only takes place when airflow is established.

- a) With the airflow established, an increase in return air relative humidity above the return air relative humidity setpoint (default 50.0%) will prompt the controller to call for dehumidification. The winter start timer (KT1) will by-pass the low pressure switch (LP1) for 3 minutes and feed the compressor contactor.
- b) Should the return air relative humidity drop above the return air relative humidity setpoint, the controller will cancel the dehumidification stage.
- c) Heating can only occur when compressor 1 is operating in the dehumidification mode and the return air temperature is below the return air temperature setpoint by the appropriate amount

DEHUMIDIFICATION OVERRIDE

During dehumidification, should the return air temperature drop below temperature setpoints then the controller will override the call for dehumidification until the heaters cause the return air temperature to be within setpoint tolerances and will then re-energise the dehumidification stage if it is required

HUMIDIFICATION

When a call for humidification exists, the microprocessor controller sends a 24V ac signal to the humidifier contactor supplying power to the boiler cylinder electrodes. The electric power dissipated in the boiler is kept constant by measuring the amount of current flow on phase (L3) via a current transformer.

As evaporation proceeds, the controller opens the fill valve allowing water to enter the cylinder via a filter and a capacity regulator to the filling cup, and from there, by gravity, to the boiler. When the water level is so high that it touches the electrodes at the top of the boiler, the fill valve is closed and the excess water is drained through overflow tube. The drain valve opens periodically to drain water and reduce salt concentration in the boiler. It is also used to drain the humidifier completely under alarm conditions.

SYSTEM OPERATION

The humidifier interface PCB maintains the electric current dissipated in the boiler at the programmed set point. The PCB therefore changes the immersion level of the electrodes by adding or draining water from the boiler through the respective valves. The operating current may be programmed on the front display panel between 30% and 100% of the rated value of the equipment. The functions of the equipment are described below:

FILL VALVE - maintains absorbed current between -10% and +10% of set point (percentages refer to rated current) by opening or closing respectively, with the first or second thresholds. The fill valve is automatically closed when:

- The drain valve is opened
- The free surface of the water reaches the level electrodes
- The system is in a state of alarm

DRAIN VALVE - this is opened when:

- The absorbed electrical current reaches set point +30% (it closes as soon as current falls set point +10%)
- The washing cycle (initial or periodic) is activated
- The system is in a state of alarm

TOP LEVEL ELECTRODES - these prevent water overflowing from the boiler. When they are covered with water for approx. three seconds the valve is closed. After the level electrodes have been out of water for approx. 25 seconds, the fill valve opens again. The level electrodes also control topping-up when absorbed current does not reach the programmed threshold because:

- The water conductivity is too low
- The electrodes are partially or totally encrusted

WASHING CYCLE - this prevents excessive salt build-up inside the boiler. It is activated as follows:

- At regular intervals, programmable according to the size of the equipment on the basis of cumulative time of humidification, memorised while the equipment is supplied with power.

ALARM CONDITION

- The red ALARM button on the front display panel lights up, the drain valve opens and electrical supply to the boiler is cut off when:

- Absorbed current exceeds 1.8 times the rated current (generally due to the fill valve overload)
- The valve remains open for more than 10 minutes without the threshold of current set point +10% being reached and without the level electrodes intervening (e.g., due to failure in the water supply, blocked intake filter, defective
- fill valve, power probe current transformer, contactor, blown fuses, encrusted electrodes, etc.)

PGD DISPLAY

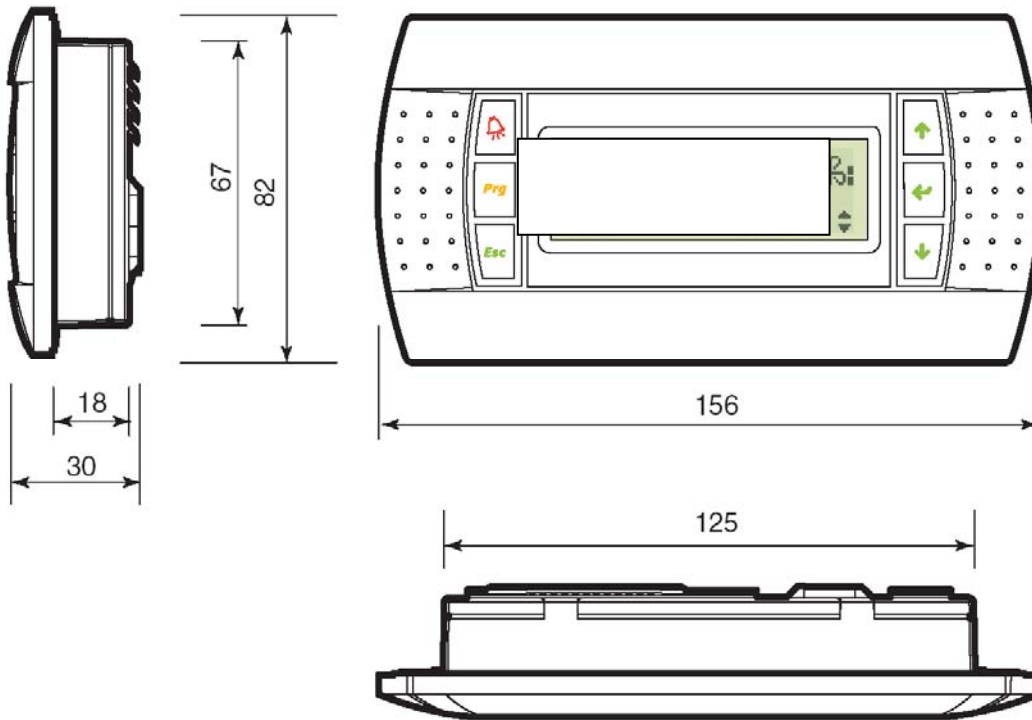

+



Turning the unit On/Off : Pressing the “ESC” & the “Enter / Return” arrow buttons together turns on and off the unit at the display. Pressing the up arrow button followed by the “Enter / Return” arrow button also turns unit on/off. Follow on screen instruction.



Alarm button: By pressing this button you can display the alarm that has occurred & reset it manually. When the red led indicator lights up, at least one alarm condition has occurred. If there are multiple alarms then using the arrow “up” & “down” buttons lets you scroll through them.



Up arrow button: Displays the program windows and allows the user to set the value of the control parameter



Down arrow button: Displays the program windows and allows the user to set the value of the control parameter. In default menu, pressing down arrow button displays unit operating mode.



Enter / Return arrow button: Confirms the set data.



Escape button: By pressing this button, you go back one level from where you are.



Program button: By pressing this button, you get a range of sub-menu's.

ALARMS

The following alarms can be activated in an alarm condition & displayed on the display screen. All alarms can be set as serious or non-serious through the keypad

ALARM LIST

AL 01	Compressor 1 HP / Thermal Overload
AL 02	Compressor 2 HP / Thermal Overload
AL 03	Compressor 1 LP
AL 04	Compressor 2 LP
AL 05	Air Flow Alarm (Serious Alarm)
AL 06	Air Flow Alarm – Slave
AL 07	Alarm Electric Reheat High Temp Trip
AL 08	Condensate Pump / High Water Level
AL 09	Smoke/Fire (Serious Alarm)
AL 10	Alarm Air Filter
AL 11	High Temperature Alarm
AL 12	Low Temperature Alarm
AL 13	High Humidity Alarm
AL 14	Low Humidity Alarm
AL 15	High Entering Water Temperature
AL 16	Low Entering Water Temperature
AL 17	Compressor 1 Run Hours
AL 18	Compressor 2 Run Hours
AL 19	Fan Run Hours
AL 20	Return Air Temperature Probe Fault Or Offline
AL 21	Entering Water Temperature Probe Fault Or Offline
AL 22	External Air Temperature Probe Fault Or Offline
AL 23	Supply Air Temperature Probe Fault Or Offline
AL 24	Return Air Humidity Probe Fault Or Offline
AL 25	Leaving Water Temperature Probe Fault Or Offline
AL 26	High Leaving Water Temperature
AL 27	Low Leaving Water Temperature
AL 28	High Current Into Humidifier
AL 29	Lack Of Water Into Humidifier
AL 30	Lack Of Current Into Humidifier
AL 31	Alarm Clock
AL 32	Spare / Custom
AL 33	Spare / Custom
AL 34	Spare / Custom
AL 35	Water Under Floor
AL 36	Loss of Water Flow Alarm

Default List : Actual Alarms Model Dependant

MAINTENANCE

GENERAL

CHECKLIST

SAFETY NOTE

This equipment is designed for safe operation provided it is installed, maintained and serviced in accordance with the guidelines laid down in this section of the manual. They should therefore be studied in advance by any person wishing to work on the equipment

The equipment contains electrical components at high voltage. The main power isolation switch should therefore be opened before access is gained to the equipment

Care should be taken to avoid hands and clothing becoming entangled in the rotating parts.

Care should be taken when working near the steam outlet pipe. This can remain hot for some time after the unit is shut down.

Any service and maintenance operations requiring access to the inside of the equipment while in operation should be carried out by an appropriately qualified or experienced person who is fully aware of the potential dangers and precautions to be taken.

The following should be incorporated in a planned maintenance schedule to ensure that the equipment is well maintained. In all cases the various sections of the equipment should be examined and any defects logged for replacement/repair. For performance analysis a detailed service/maintenance log book should be kept outlining problems encountered and defects found during routine maintenance. Examples can be found at the end of this section.

COMMON COMPONENTS.

CABINET AND FRAME - EXAMINE

- 1) Examine the cabinet exterior for any obvious defects or damage and repair as necessary.
- 2) Remove the front, side and rear panels and examine the cabinet interior for signs of damage or corrosion. Repair any damage found and restore the surface finish where corrosion has occurred.
- 3) Refit the front, side and rear panels and restore the electrical supply to the unit.
- 4) Record and report any defects found during the inspection.

DRIVE PACKAGE

- 1) Remove the unit front panels and inspect the fan motor for any loose electrical connections and retighten as necessary.
- 2) Inspect the fan impellers and remove any debris.
- 3) Check that the fan impellers are securely mounted on the fan shaft. Rotate the impellers and ensure freedom of movement.
- 4) Inspect the bearings for signs of wear. If any excessive movement is noticed the bearings must be renewed.
- 5) Check the drive belts monthly for signs of wear and proper tension. Pressing on the belts midway between the sheave and pulley should produce approx. 12.5mm of movement. Belts that are too tight can cause excessive bearing wear.

DRIVE BELT RE-TENSIONING

- 1) Correctly tension the belts by adjusting the fan motor slide base as necessary.

Note:

If belts appear cracked or worn, they should be renewed with matched belts (identically sized). On units with twin belt drives both belts should be renewed at the same time. With proper care, belts should provide a long service life.

- 2) After adjusting or renewing the belts, always check that the motor mounts are tight. Loose mounts will produce vibration that may damage the unit.

AIRFLOW SWITCH

- 1) Open the unit front panel and inspect the airflow switch located below the electric panel for any loose electrical connections and retighten as necessary.
- 2) Examine the pressure sensing tube between the switch and the fan casing for defects, damage and loose connections. Renew the tube if necessary.
- 3) Refit the unit front panel and restore the electrical supply to the unit.
- 4) Record and report any defects found during the inspection.

AIR FILTERS

To maintain efficient operation, the air filters should be checked monthly and renewed as required. Because renewal intervals may vary with environmental conditions and filter type, each unit is equipped with a filter clog switch which warns of restricted air flow through the filter compartment by activating the 'Change Filter' alarm.

- 1) On downflow models the filters can be removed from the top of the unit, whereas on upflow units the bottom front panel contains the filters.
- 2) Fit new filters, refit the unit front panel on upflow units and restore the power supply.

STEAM GENERATING HUMIDIFIER

Remove the unit front panels and examine the humidifier for any loose electrical connections. Retighten any loose connections. Examine all pipes and connections for defects, damage and security of attachment. Ensure that the steam generating canister is properly secured to the unit frame. Refit the unit front and side panels and restore the electrical supply to the unit. Record and report any defects found during the inspection.

REFRIGERATION COMPONENTS

COMPRESSOR

- 1) Remove the front panel and examine the compressor for any obvious defects. Correct any defects found.
- 2) Examine the compressor vibration isolation mounts for defects and security. Retighten the mounts if necessary.
- 3) Inspect the refrigerant pipework connections for signs of oil leaks.
- 4) Examine the service valves for defects and signs of oil leaks.
- 5) Remove the compressor terminal cover and examine the electrical connections for damaged insulation. Retighten any loose connections.
- 6) Refit the compressor terminal cover and refit the unit front panel.
- 7) Restore the electrical supply to the unit.
- 8) Record and report any defects found during the inspection.

REFRIGERANT LINES

- 1) Remove the unit front panel.
- 2) As far as possible, examine the refrigerant pipework for defects, damage and signs of oil leaks.
- 3) Examine the pipework for frictional or mechanical damage, particularly where pipes pass through the frame structure.
- 4) Check pipe brackets/clamps to ensure that they are properly secured.
- 5) Ensure that the insulation is sound and properly secured around the pipes.
- 6) Refit the unit front panel.
- 7) Restore the electrical supply to the unit.
- 8) Record and report any defects found during the inspection.

EVAPORATOR COIL

- 1) Remove the unit front panels and inspect the coil for defects, damage and corrosion.
- 2) Check that the coil fins are in good condition. If they are found to be bent, they should be carefully straightened using a proprietary fin comb.
- 3) Inspect the refrigerant pipework connections for signs of oil leaks.
- 4) Refit the unit front panels and restore the electrical supply to the unit.
- 5) Record and report any defects found during the inspection.

LIQUID LINE SIGHT GLASS

- 1) Check the sight glass moisture indicator. If moisture is shown to be present in the system a new filter dryer must be fitted.
- 2) Refit the unit front panels and restore the electrical supply to the unit.
- 3) Record and report any defects found during the inspection.

FILTER-DRYER

- 1) Open the unit front panels and locate the filter-dryer.
- 2) Examine the filter-dryer canister for defects or damage. Correct any defects found.
- 3) Inspect the refrigerant sight glass for dirt particles. If present, renew the filter-dryer.
- 4) Inspect the refrigerant pipework connections for signs of oil leaks.
- 5) Refit the unit front panels and restore the electrical supply to the unit.
- 6) Record and report any defects found during the inspection.

WATER COOLED UNITS

BRAZED PLATE CONDENSER

- 1) Remove the unit front panels.
- 2) As far as possible, examine the refrigerant and coolant pipework for defects, damage and signs of oil leaks.
- 3) Refit the unit front panels and restore the electrical supply to the unit.
- 4) Record and report any defects found during the inspection.

REGULATING VALVES

- 1) Remove the unit front panels.
- 2) Visually inspect the valve(s) for damage and ensure that the connections are not leaking.
- 3) Ensure that the valve(s) are securely mounted in position.
- 4) Ensure that capillary tube(s) are secure and no leaks are present.
- 5) Refit the unit front panels and restore the electrical supply to the unit.
- 6) Record and report any defects found during the inspection.

WATER SOLUTION - CHECK

It is difficult to establish a specific schedule of inhibitor maintenance since the rate of inhibitor depletion depends upon local water conditions. Analysis of water samples at the time of installation and every six months thereafter should help to establish a pattern of depletion. A visual inspection of the solution and filter residue is often helpful in judging whether or not active corrosion is occurring.

The complexity of water-caused problems and their correction makes it important to obtain the advice of a water treatment specialist, and a regularly scheduled maintenance program should be followed. It is important to note that the improper use of water treatment chemicals can result in problems more serious than using no chemicals at all.

ELECTRIC PANEL - INSPECTION AND FUNCTIONAL CHECKS

GENERAL

Open the unit front, inspect the electric panel for any damage or loose electrical connections and re-tighten as necessary.

Note: -The functioning of all control circuits can be tested by actuating each of the main functions, by adjusting the set points.

COOLING FUNCTIONAL TEST

Select a set point for a temperature of 6°C below room temperature.

- a) A call for cooling should be observed.
- b) The compressor contactor should energise, and the equipment should begin to cool.
- c) A high temperature alarm may enunciate. Disregard it.

Return the set point to the room temperature.

REHEAT FUNCTIONAL TEST

Select a temperature set point for 6°C above the room temperature.

- a) A call for heating should be observed.
- b) Both heating contactors should energise, and the heating elements should begin to heat.
- c) Disregard the low temperature alarm.
- d) Return the set point to the desired temperature.

HUMIDIFICATION FUNCTIONAL CHECK

Set the humidification to 10%RH above the room humidity reading.

- a) For a steam generating humidifier, you will immediately hear clicks as it energises. After a short delay, the canister will fill with water. The water will heat and steam will be produced.

Return the humidity setting to the desired room relative humidity setting.

DEHUMIDIFICATION FUNCTIONAL CHECK

Set the humidification setpoint to 10%RH below the room humidity reading. Make sure that the temperature set point is at or above room temperature.

- a) The compressor contactor should energise and the system should begin to cool/dehumidify.

Return the humidity setting to the desired room relative humidity setting.

NOTE: - IN CHILLED WATER SYSTEMS THE VALVE OPENS PROPORTIONALLY.

THE BASIC CONTROL CHECKS ARE NOW COMPLETED.

- 1) Replace the unit front panels and restore the electrical supply to the unit.
- 2) Record and report any defects found during the inspection.

STEAM GENERATING HUMIDIFIER - CLEANING AND RENEWAL

NOTE: REGULAR MAINTENANCE IS LIMITED TO DESCALING OR RENEWING THE BOILER. NECESSARY WHEN SCALE ON THE ACTIVE SURFACES OF THE ELECTRODES PREVENTS PASSAGE OF ELECTRICAL CURRENT.

In the case of serviceable humidifiers the bottle can be dismantled and thoroughly

- 1) Drain the water completely. (See Controls Manual for details on drain procedure).
- 2) Disconnect the power supply to the equipment.
- 3) Unscrew the steam pipe from the boiler.
- 4) Disconnect the wiring to the main electrodes and the level electrodes.
- 5) Unhook the holding spring and unscrew the humidifier bottle by rotating it anti-clockwise on its axis.
- 6) Remove the bottle.

NOTE: - THE BOILER MAY GENERALLY BE USED AGAIN AFTER DESCALING.

- 7) Unscrew the ring nut and extract the bottom filter. Remove any scale and deposits jet of water and clean the grids mechanically or chemically with a commercially available cleaner.

NOTE: - WHEN ELECTRODE WEAR IS SUCH THAT REGENERATION IS INSUFFICIENT, THE MUST BE RENEWED.

- 8) Reassemble the boiler in the reverse sequence after checking and if necessary, renewing the washer between the threaded connection and the discharge outlet.



THIS IS SUFFICIENT cleaned.

under a BOILER

THERMOSTATIC EXPANSION VALVE – CALIBRATION

SUPERHEAT - CALCULATION AND ADJUSTMENT CALCULATION

- 1) Measure the temperature of the suction line at the point where the TEV bulb is clamped.
- 2) Obtain the gauge pressure at the compressor suction valve.
- 3) Convert the sum of the two pressures to the equivalent temperature.
- 4) Subtract this temperature from the actual suction line temperature obtained in Step 1. The difference is the superheat value.

ADJUSTMENT

- 1) Remove the cap at the bottom of the thermostatic expansion valve.

NOTE: MAKE NO MORE THAN A 1/4 TURN OF THE STEM AT A TIME. AS LONG AS 15 MINUTES MAY BE REQUIRED FOR THE NEW BALANCE TO TAKE PLACE.

- 2) Turn the adjusting stem counter-clockwise to lower the superheat.
- 3) Turn the adjusting stem clockwise to increase the superheat.

PLATE HEAT EXCHANGER – CLEANING

Each water or Water cooled module has a brazed plate condenser.

It may be necessary to clean the copper tubing periodically to remove any deposits of lime scale. (Periods between cleaning will vary with local water conditions).

- 1) Stop the unit (using the start/stop switch).
- 2) Open the main power load break switch.
- 3) Shut off the water supply to the condenser.
- 4) Drain all water from the condenser and piping.
- 5) Reconnect the piping, open the water supply, vent the system and check for leaks.
- 6) Restart the system by closing the main power load break switch and continue to check for leaks with the system running. Once it has been established that no leaks are present, the unit panels can be refitted.

WATER REGULATING VALVES - MANUAL FLUSHING

It will be necessary to dismantle the valve to clean the seat if leakage past the valve seat is suspected.

- 1) Shut off the water supply.
- 2) Relieve the tension on the main spring by turning the adjusting screw clockwise as far as it will go. (Provide a means of containing water below the valve.)
- 3) Remove the four screws extending through the main spring housing from the end of the valve opposite the bellows.
- 4) Remove the centre assembly screws, this allows access to all internal parts.
- 5) Clean the seat if possible. If the seat is pitted or damaged, renew the valve rubber disc and valve seat.
- 6) After the valve is reassembled check for leaks.

TESTING FUNCTION OF VALVE

When the refrigeration system has been off for approximately 10 to 15 minutes, the water flow should stop.

Should the water continue to flow, the valve is either improperly adjusted (with too low a head pressure) or the pressure sensing capillary is not properly connected to the condenser hot gas schraeder port.

REGULATING VALVES - ADJUSTMENT

The valve can be adjusted with a standard refrigeration service valve wrench or screw driver.

To lower the head pressure setting, turn the square adjusting screw clockwise until the high pressure gauge indicates the desired setting.

To raise the head pressure setting, turn the adjusting screw counter clockwise until the desired setting is obtained.

REFRIGERANT CONTROL SETTINGS

The pressure switches fitted are of the encapsulated type and are set and tested by the manufacturer prior to despatch.

Switch settings are as indicated in the chart opposite:

	OPENS	CLOSES
LOW PRESSURE SWITCH	2 BAR	3.5 BAR
HIGH PRESSURE SWITCH	25 BAR	MANUAL – RESET AT 19 BAR

FAULT FINDING GUIDE

SYMPTOM	POSSIBLE CAUSE	REMEDY
No Power (Green On/Off control button not lit)	No power to the unit electric panel	Check that the electrical power source is live and the main disconnect switch is closed
	No power to the control circuit	1) Check that the control circuit breaker is closed 2) Check the 24V secondary fuse
THE UNIT DOES NOT OPERATE	The display does not operate the unit	1) Check the display connection. 2) Check the processor connections 3) Refer to the unit electrical schematic and user control manual
ROOM TEMPERATURE TOO HIGH Unit high Temperature Alarm	1) Controls not properly set	Check the room temperature setpoint - Refer to User Control Manual
	2) Lack of airflow	See "LACK OF AIRFLOW" section
	3) The compressor does not work when required by the controller	See "THE COMPRESSOR DOES NOT WORK" section
	4) Insufficient compressor output	1) See "COMPRESSOR HIGH DISCHARGE PRESSURE" section 2) See "COMPRESSOR LOW SUCTION PRESSURE" section
	5) The control system does not operate properly	See "User Control Manual". Check that the display and processor and/or the sensor function properly
	6) Heat load higher than expected	1) Check the room heat load 2) Check the condition and volume of fresh air make-up 3) Check the quantity of infiltration of external air
ROOM TEMPERATURE TOO LOW Unit High Temperature Alarm	1) Controls not properly set	Check the room temperature setpoint - Refer to User Control Manual
	2) The heater does not work properly (if fitted)	1) Check the heating elements 2) Check the electric heater MCB 3) In the case if electric heater alarm, eliminate the cause and re-set the safety thermostat
	5) The control system does not operate properly	See "User Control Manual". Check that the display and processor and/or the sensor function properly
	6) Thermal losses higher than expected	Check the room heat loss calculations, check the quantity of infiltration of external air
ROOM RELATIVE HUMIDITY TOO HIGH Controller high humidity alarm	1) Controls not properly set	Check the room humidity setpoint - Refer to User Control Manual
	2) Latent load higher than expected	Check the room latent load, check the quantity of infiltration of external air
	3) The compressor does not work in the dehumidification mode	see "THE COMPRESSOR DOES NOT WORK" section
	4) The control system is not functioning properly	See "User Control Manual". Check that the display and/or the sensor are functioning properly
ROOM RELATIVE HUMIDITY TOO LOW Controller low humidity alarm	1) Controls not properly set	Check the room humidity setpoint - Refer to User Control Manual
	2) Latent load higher than expected	Check the room latent load, check the quantity of infiltration of external air
	3) The humidifier does not function properly	1) Check the make-up water pressure 2) Check the humidifier and cylinder

SYMPTOM	POSSIBLE CAUSE	REMEDY
LACK OF AIRFLOW Loss of Airflow alarm	1) No power to the fan motor	Check the fan motor MCB and electric supply at the motor box terminals
	2) Clogged filters	Replace the filters
	3) The airflow is obstructed	Check fan inlets, air intake and supply paths are free
	4) The main fan overload has tripped	Check the electrical resistance of the motor windings. After re-set, measure the supply voltage and current drawn.
	5) The pressure drop in the air distribution system (ducts, ceilings, flooring, plenum, grilles, etc.) is too high	Check the design and sizing of the air distribution system
COMPRESSOR HIGH DISCHARGE PRESSURE	1) Presence of air or non condensable gases in the refrigeration circuit	Purge the system and recharge
	2) The airflow of the remote heat exchanger is insufficient or too warm	1) Check the remote heat exchanger fan 2) Check that the remote heat exchanger is not clogged, remove all foreign (leaves, paper, etc.) 3) Check for any short circuiting of cooling air 4) check that the cooling air temperature is not higher than the design value
	3) The condensing pressure control system is not working properly	1) Check the operation of the condenser fan and its overload protection. 2) Check the adjustment and operation of the condenser fan speed controller see (CONDENSING PRESSURE CONTROL) section.
	4) The water flow to the water cooled condenser is insufficient or too hot	1) Check the temperature and pressure of the cooling water 2) Check the adjustment and operation of the pressure operated water regulating valve
	5) Circuit overloaded with refrigerant, condenser partially flooded	Remove some refrigerant from the circuit
	6) Service valve on the high pressure side partially closed	Check that all service valves are open
COMPRESSOR LOW DISCHARGE PRESSURE	1) The condensing pressure control system does not work properly	Check the set point and the operation of the remote condenser fan pressure switch or of the fan speed controller (see CONDENSING PRESSURE CONTROL section)
	2) Cooling water flow rate too high or temperature too low	1) Check the temperature of the cooling water 2) Check the adjustment and operation of the water regulating valve
COMPRESSOR HIGH SUCTION PRESSURE	1) Heat load higher than expected	1) Check the room heat load 2) Check the condition and volume of fresh air make-up 3) Check the quantity of infiltration of external air
	2) High discharge pressure	See COMPRESSOR HIGH DISCHARGE PRESSURE
	3) Circuit overloaded with refrigerant	Remove some refrigerant from the circuit
	4) Return of liquid refrigerant to the compressor	1) Check the superheat of the expansion valve is correct 2) Check that the valve bulb has not lost it's charge and is positioned properly, fixed and insulated

SYMPTOM	POSSIBLE CAUSE	REMEDY
COMPRESSOR LOW SUCTION PRESSURE (and possible coil freezing)	1) Low room temperature	See ROOM TEMPERATURE TOO LOW
	2) Lack of air	See LACK OF AIR FLOW
	3) Refrigerant suction valve not completely open	Open the valve completely
	4) Insufficient liquid refrigerant supply to expansion valve: bubbles in the sight glass	1) Check the refrigerant filter and replace it if blocked up 2) Check the refrigerant charge and rectify any leaks and recharge system
	5) Thermostatic expansion valve maladjusted or defective	1) Check the superheat of the expansion valve is correct 2) Check that the valve bulb has not lost its charge and is positioned properly, fixed and insulated
	6) Low discharge pressure	See COMPRESSOR LOW DISCHARGE PRESSURE
THE COMPRESSOR SUCTION LOW PRESSURE SWITCH CUTS OUT (L.P. alarm)	1) Shortage of refrigerant at the thermostatic expansion valve inlet	Check that there is sufficient refrigerant in the system.
	2) Low pressure switch faulty	Replace the switch
	3) The suction pressure in the circuit is too low	See COMPRESSOR LOW SUCTION PRESSURE
THE COMPRESSOR DOES NOT WORK	1) The MCB has tripped	Reset the MCB and check the cause of the fault
	2) The internal protection of the compressor has tripped	Check the electrical resistance of the compressor winding, after reset measure the supply voltage and current drawn
	3) The compressor contactor is faulty	Check the contacts and the coil of the contactor
THE COMPRESSOR IS NOISY	1) Return of liquid refrigerant to the compressor	Check the operation and the superheat of the thermostatic expansion valve
THE HEATER SAFETY THERMOSTAT CUTS OUT (Heater trip alarm)	1) Lack of airflow	See LACK OF AIR FLOW
	2) Thermostat faulty connection wire	Check the electrical continuity of the safety thermostat connection to the controller
	3) Defective thermostat	Replace the heater safety thermostat

MONTHLY MAINTENANCE INSPECTION CHECK

MODEL NUMBER

SERIAL NUMBER

DATE

INSPECTOR

FILTERS

- Check filter switch (if fitted)
- Inspect filters and replace if necessary

DRIVE PACKAGE

- Blower impellers moving freely and free of debris
- Check belt tension and condition
- Bearings in good condition
- Check airflow switch setting and operation.
- Check pulley and sheave are secure
- Inspect blower anti-vibration mounts

AIR COOLED CONDENSER (IF APPLICABLE)

- Condenser coil clean
- Fans rotating freely
- Refrigerant lines properly secured

STEAM HUMIDIFIER

- Check humidifier bottle for deposits
- Check condition of steam hoses

COMPRESSOR

- Check service valves are open

REFRIGERATION SECTION

- Check refrigerant lines are properly secure
- Check sightglass for indication of moisture
- Check suction pressure
- Check discharge pressure
- Check expansion valve

GENERAL NOTES AND OBSERVATIONS
