

CSRN-XHE2 15.2-44.4

High efficiency "Roof Top" air cooled heat pump



Dear Customer,

We congratulate you on choosing this product

For many years Clivet has been offering systems that provide maximum comfort, together with high reliability, efficiency, quality and safety.

The aim of the company is to offer advanced systems, that assure the best comfort, reduce energy consumption and the installation and maintenance cost for the life cycle of the system.

The purpose of this manual is to provide you with information that is useful from reception of the equipment, through installation, operational usage and finally disposal so that this advanced system offers the best solution.

Yours faithfully,

CLIVET Spa

The data contained in this manual is not binding and may be changed by the manufacturer without prior notice.

Reproduction, even in part, is FORBIDDEN © Copyright - CLIVET S.p.A. - Feltre (BL) - Italia

Index of contents

1	General description	4
2	Reception	6
3	Positioning	8
4	Water connections	10
5	Aeraulic connections	11
6	Electrical connections	12
7	Start-up	16
8	Control	22
9	Maintenance	28
10	Accessories	33
11	Decommissioning	42
12	Residual risks	43
13	Technical information	44
14	Dimensional drawings	47

1 General description

1.1 Manual

The manual provides correct unit installation, use and maintenance.

Pay particular attention to:



Warning, identifies particularly important operations or information.



Prohibited operations that must not be carried out, that compromise the operating of the unit or may cause damage to persons or things.

- It is advisable to read it carefully so you will save time during operations.
- Follow the written indications so you will not cause damages to things and injuries people.

1.2 Preliminaries

Only qualified personnel can operate on the unit, as required by the regulation in force.

1.3 Risk situations



The unit has been designed and created to prevent injuries to people.

During designing it is not possible to plane and operate on all risk situation.

Read carefully "Residual risk" section where all situation which may cause damages to things and injuries to people are reported.

Installation, starting, maintenance and repair required specific knowledge; if they are carried out by inexperienced personnel, they may cause damages to things and injuries people.

1.4 Intended use

Use the unit only:

- civil air-conditioning
- keep to the limits foreseen in the technical schedule and in this manual

The manufacturer accepts no responsibility if the equipment is used for any purpose other than the intended use.

1.5 Installation

Outdoor installation



The positioning, hydraulic system, refrigerating, electrics and the ducting of the air must be determined by the system designer in accordance with local regulations in force.

Follow local safety regulations.

Verify that the electrical line characteristics are in compliance with data quotes on the unit serial number label.

1.6 Maintenance

Plan periodic inspection and maintenance in order to avoid or reduce repairing costs.



Turn the unit off before any operation.

1.7 Modification



All unit modifications will end the warranty coverage and the manufacturer responsibility.

1.8 Breakdown/Malfuction

Disable the unit immediately in case of breakdown or malfunction.

Contact a certified service agent.

Use original spares parts only.

Using the unit in case of breakdown or malfunction:

- voids the warranty
- it may compromise the safety of the unit
- may increase time and repair costs

1.9 User training



The installer has to train the user on:

- Start-up/shutdown
- Set points change
- Standby mode
- Maintenance
- What to do / what not to do in case of breakdown

1.10 Data update

Continual product improvements may imply manual data changes.

Visit manufacturer web site for updated data.

1.11 Indications for the User



Keep this manual with the wiring diagram in an accessible place for the operator.

Note the unit data label so you can provide them to the assistance centre in case of intervention (see "Unit identification" section).

Provide a unit notebook that allows any interventions carried out on the unit to be noted and tracked making it easier to suitably note the various interventions and aids the search for any breakdowns.

In case of breakdown or malfunction:

- Immediately deactivate the unit
- Contact a service centre authorized by the manufacturer



The installer must train the user, particularly on:

- Start-up/shutdown
- Set points change
- Standby mode
- Maintenance
- What to do / what not to do in case of breakdown

1.12 Unit identification

The serial number label is positioned on the unit and allows to identify all the unit features.



The matriculation plate must never be removed.

The matriculation plate shows the indications foreseen by the standards, in particular:

- unit type
- serial number (12 characters)
- year of manufacture
- wiring diagram number
- electrical data
- manufacturer logo and address

1.13 Serial number

It identifies uniquely each unit.

Must be quoted when ordering spare parts.

1.14 Assistance request

Note data from the serial number label and write them in the chart on side, so you will find them easily when needed.

Series
Size
Serial number
Year of manufacture
Electrical wiring diagram

2 Reception



You have to check before accepting the delivery:

- That the unit hasn't been damaged during transport
- That the materials delivered correspond with that indicated on the transport document comparing the data with the identification label positioned on the packaging.

In case of damage or anomaly:

- Write down on the transport document the damage you found and quote this sentence: "Conditional acceptance clear evidence of deficiencies/damages during transport"
- Contact by fax and registered mail with advice of receipt to supplier and the carrier.



Any disputes must be made within 8 days from the date of the delivery. Complaints after this period are invalid.

2.1 Storage

Observe external packaging instructions.

2.2 Handling

1. Verify unit weight and handling equipment lifting capacity.
2. Identify critical points during handling (disconnected routes, flights, steps, doors).
3. Suitably protect the unit to prevent damage.
4. lifting brackets
5. Lifting with balance
6. Lifting with spacer bar
7. Align the barycenter to the lifting point
8. Use all the lifting brackets (see the dimensional section)
9. Gradually bring the lifting belts under tension, making sure they are positioned correctly.
10. Before starting the handling, make sure that the unit is stable.

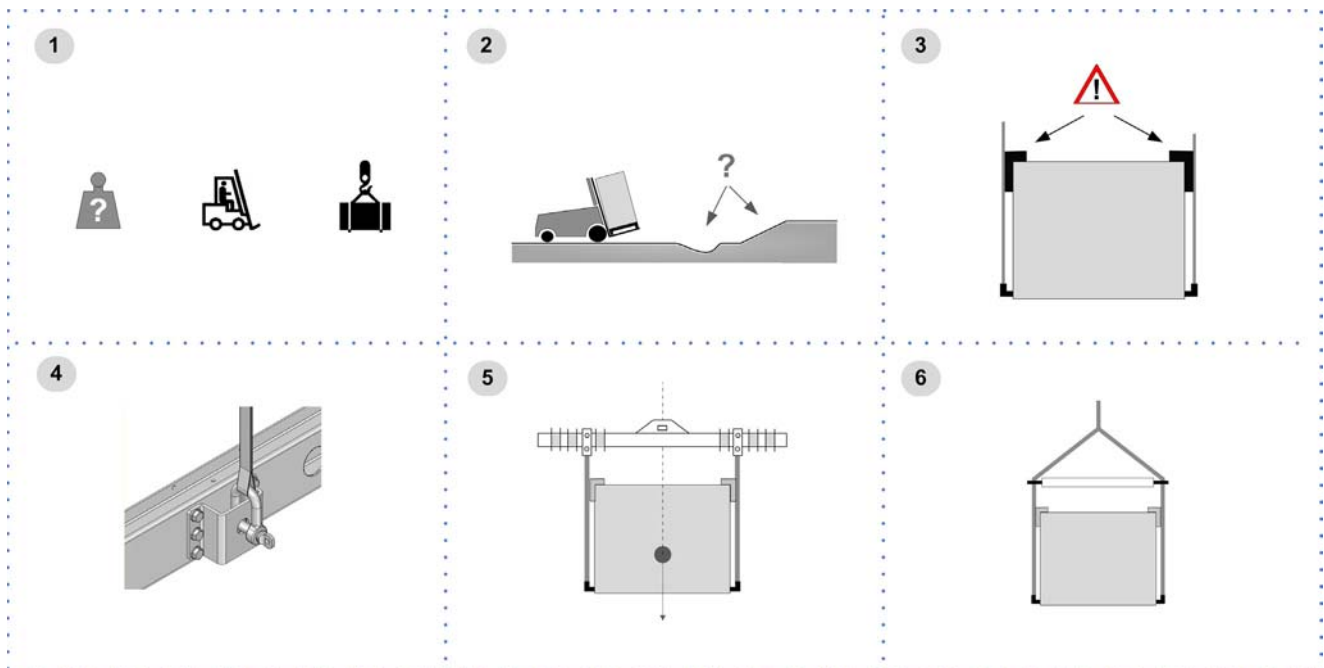

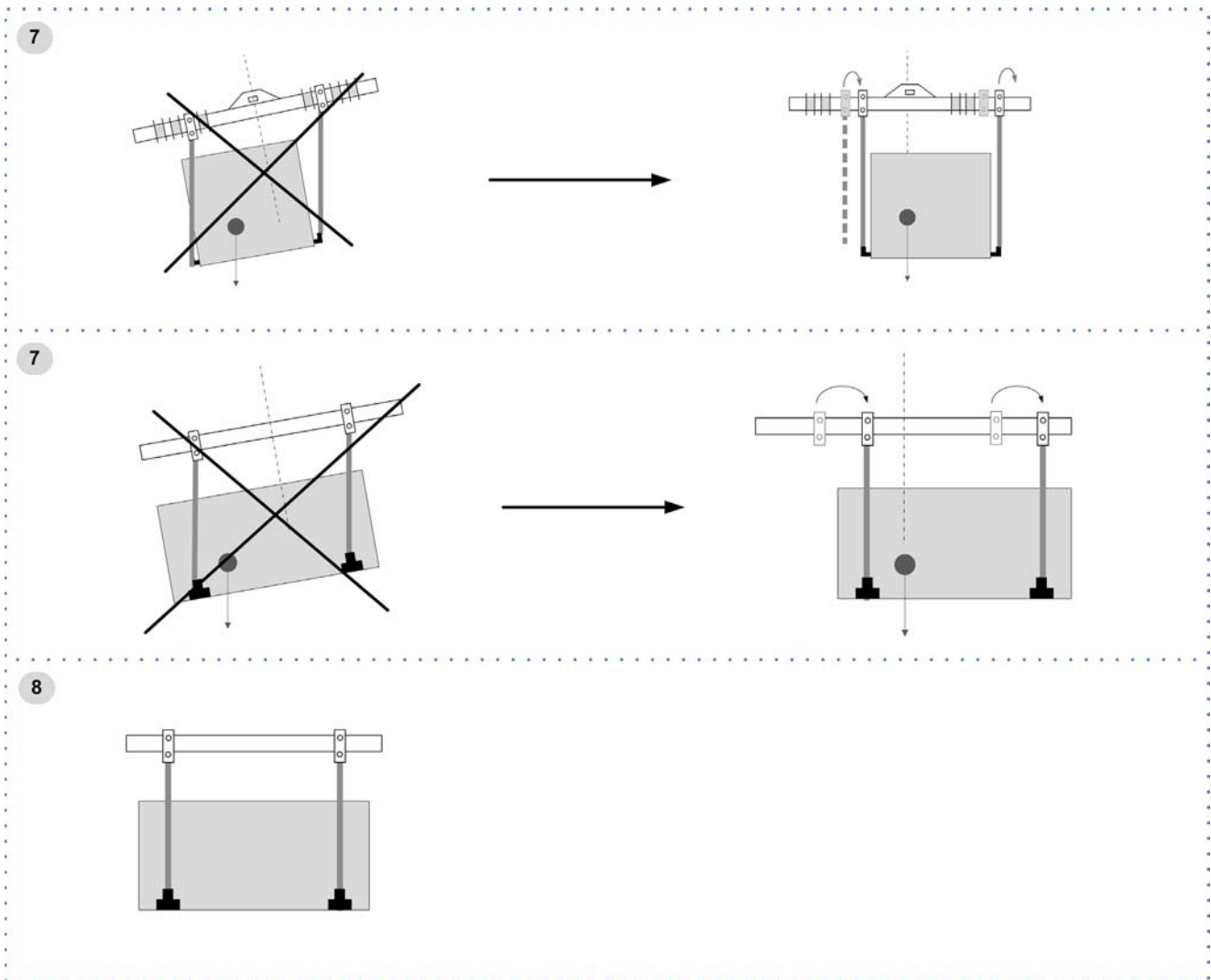

2.3 Packaging removing

Be careful not to damage the unit.

Keep packing material out of children's reach it may be dangerous.

Recycle and dispose of the packaging material in conformity with local regulations.



A Supports for handling: remove after the handling.

B Remove the coil protective mesh before the start-up

3 Positioning

During positioning consider these elements:

- Technical spaces requested by the unit
- Electrical connections
- Water connections
- Spaces for air exhaust and intake

3.1 Functional spaces

Functional spaces are designed to:

- guarantee good unit operation
- carry out maintenance operations
- protect authorized operators and exposed people

Respect all functional spaces indicated in the DIMENSIONS section.

Double all functional spaces if two or more unit are aligned.

3.2 Positioning



Units are designed to be installed:

- EXTERNAL
- in fixed positions

Limit vibration transmission:

- use anti-vibration devices or neoprene strips on the unit support points
- install flexible joints on the hydraulic connections
- install flexible joints on the hydraulic connections

Choose the installation place according to the following criteria:

- Customer approval
- safe accessible position
- technical spaces requested by the unit
- spaces for the air intake/exhaust
- max. distance allowed by the electrical connections
- install the unit raised from the ground
- verify unit weight and bearing point capacity
- verify that all bearing points are aligned and leveled
- condensate water draining
- consider the maximum possible snow level
- avoid flood-prone places

Protect the unit with suitable fence in order to avoid access to unauthorised personnel (children, vandals, etc.)

A correct circulation of the air is mandatory to guarantee the good unit operating.



Avoid therefore:

- obstacles to the airflow
- difficulty of exchange
- leaves or other foreign bodies that can obstruct the air coil
- winds that hinder or favour the airflow
- heat or pollution sources close to the unit (chimneys, extractors etc..)
- stratification (cold air that stagnates at the bottom)
- recirculation (expelled air that is sucked in again)
- incorrect positioning, close to very high walls, attics or in angles that could give rise to stratification or recirculation phenomenons

Ignoring the previous indications could:

- reduce energy efficiency
- alarm lockout due to HIGH PRESSURE (in summer) or LOW PRESSURE (in winter)

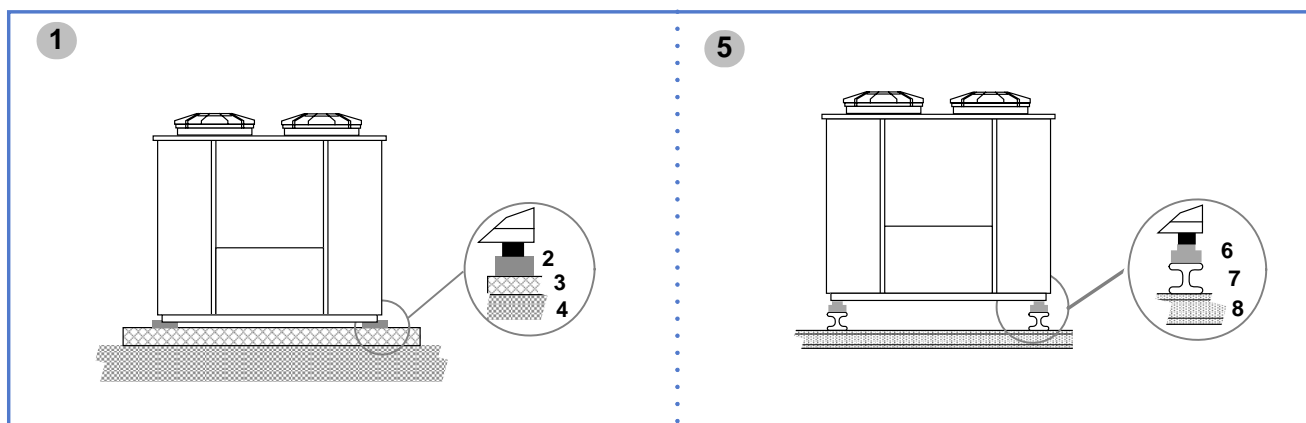

- 1 Positioning on concrete floor
- 2 2 cm thick neoprene strips
- 3 concrete floor
- 4 insulation

- 5 Positioning on steel structure
- 6 antivibration mounts
- 7 steel structure
- 8 steel structure

⊘ Avoid the accumulation of snow and ice in front of the exhaust air outlet

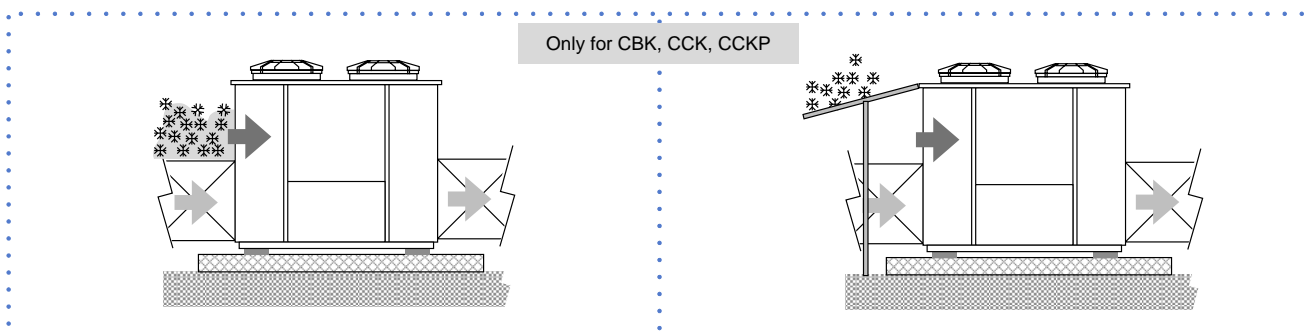

3.3 Safety valve gas side

The installer is responsible for evaluating the opportunity of installing drain tubes, in conformity with the local regulations in force (EN 378).

3.4 Condensate water

When a heat pump is running it produces a considerable amount of water due to the defrosting cycles of the external coil. The condensate must be disposed in order to avoid damages to people and things.

3.5 CCK, CCKP configuration

Fissare tramite le 4 viti M6x20 e rondelle ogni cuffia fornita

Fix with 4 screws M6x20 and washers both headphone supplied

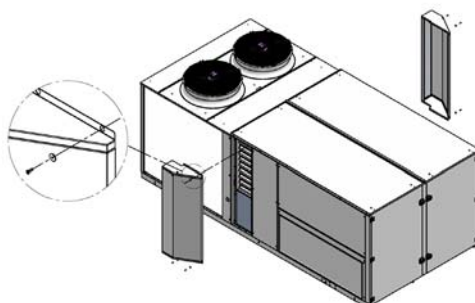

3.6 Gas heating module - Electronic filters

For details see:
10 Accessories p. 33

4 Water connections

4.1 Condensate drain

The condensate must be disposed in order to avoid damages to people and things.

- Unit discharge fitting: the connection must not transmit mechanical stresses and must be performed taking care not to damage the unit discharge fitting.
- Provide a siphon that, eliminating the negative pressure caused by the fan, prevents the air intake from the discharge duct.
- The ducting must have a min. slope of 3% to allow the runoff.
- Anchor the ducting with an adequate number of supports.
- Insulate the duct and the siphon to avoid the condensate drippings.
- Connect the condensate discharge to a sewerage drainage network.



DO NOT use white water or drainage networks to avoid the aspiration of odours in the case of evaporation of water contained in the siphon.



Check at the end of the work, the regular condensate runoff pouring some water in the tray.

For details see:

Dimensional drawings

4.2 Risk of freezing

If the unit or the relative water connections are subject to temperatures close to 0°C:

- mix water with glycol, or
- safeguard the pipes with heating cables placed under the insulation, or
- empty the system in cases of long non-use

4.3 Anti-freeze solution

The use of an anti-freeze solution results in an increase in pressure drop.



Make sure that the glycol type utilized is inhibited (not corrosive) and compatible with the water circuit components.



Do not use different glycol mixture (i.e. ethylene with propylene).

4.4 Humidifier

For details see:

10 Accessories p. 33

5 Aeraulic connections

The dimensioning and correct execution of the aeraulic connections are fundamental to guarantee good unit operation and adequate level of silence in the room.

When designing and manufacturing the ducting, consider LOAD LOSSES, AIR FLOW AND SPEED that must be consistent with the unit features.



Particularly consider that load losses higher than the unit useful prevalence, lead to reduction in flow rate, with consequent unit blocks.

- the weight of the channels must not burden on the connection flanges
- place anti-vibration joints between channels and unit
- connection to the flanges and between the various sections of the channels must guarantee air seal, avoiding dispersions penalising the overall efficiency of the system
- limit the load losses by optimising the path, the type and number of bends and junctions
- use wide bends evaluating the opportunity of equipping them with deflectors (in particular with high air speed or bends with reduced radius)

5.1 Treated air channelling

The internal surface of the channel must be smooth, enable its washing and must not contaminate the air.

Thermally isolate the channels and the flanges to avoid energy losses and forming of condensation.

DIFFUSERS INLETS GRILLES

A correct diffusion of the air in the room is determining for the level of comfort.



When choosing and positioning the grilles, inlets and diffusers, avoid:

- excessive air speed
- forming of stagnant and stratification areas
- cold air delivery in room
- forming of localised currents (also due to uneven distribution of air)
- excessive room temperature variations, vertically and horizontally
- short circuits of the supply air towards the return air



For sound comfort, consider that:

- the air diffusers must be chosen verifying the sound power generated at nominal flow rate conditions
- the cut-off to diffusers must be carried out with flexible elements
- the return grilles must be widely dimensioned

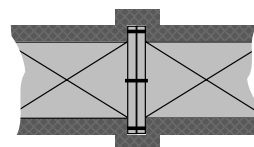
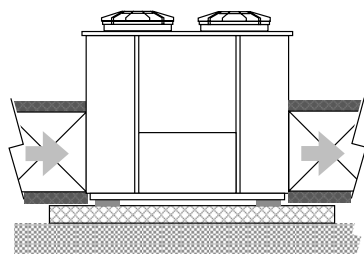

Thermally isolate the channels and the flanges to avoid energy losses and forming of condensation.

6 Electrical connections

The characteristics of the electrical lines must be determined by qualified electrical personnel able to design electrical installations; moreover, the lines must be in conformity with regulations in force.

The protection devices of the unit power line must be able to stop all short circuit current, the value must be determined in accordance with system features.

The power cables and the protection cable section must be defined in accordance with the characteristics of the protections adopted.

All electrical operations should be performed by trained personnel having the necessary qualifications required by the regulations in force and being informed about the risks relevant to these activities.

Operate in compliance with safety regulations in force.

6.1 Electrical data



The serial number label reports the unit specific electrical data, included any electrical accessories.

The electrical data indicated in the technical bulletin and in the manual refer to the standard unit, accessories excluded.

The matriculation plate shows the indications foreseen by the standards, in particular:

- Voltage
- F.L.A.: full load ampere, absorbed current at maximum admitted conditions
- F.L.I.: full load input, full load power input at max. admissible condition
- Electrical wiring diagram Nr.

6.2 Connections

1. Refer to the unit electrical diagram (the number of the diagram is shown on the serial number label).
2. Verify that the electrical supply has characteristics conforming to the data shown on the serial number label.
3. Before starting work, ensure the unit is isolated, unable to be turned on and a safety sign used.
4. Ensure correct earth connection.
5. Ensure cables are suitably protected.
6. Before powering up the unit, make sure that all the protections that were removed during the electrical connection work have been restored.

6.3 Signals / data lines

Do not exceed the maximum power allowed, which varies, according to the type of signal.

Lay the cables far from power cables or cables having a different tension and that are able to emit electromagnetic disturbances.

Do not lay the cable near devices which can generate electromagnetic interferences.

Do not lay the cables parallel to other cables, cable crossings are possible, only if laid at 90°.

Connect the screen to the ground, only if there aren't disturbances.

Guarantee the continuity of the screen during the entire extension of the cable.

Respect impedance, capacity and attenuation indications.

6.4 Power input



Fix the cables: if vacated may be subject to tearing.



The cable must not touch the compressor and the refrigerant piping (they reach high temperatures).

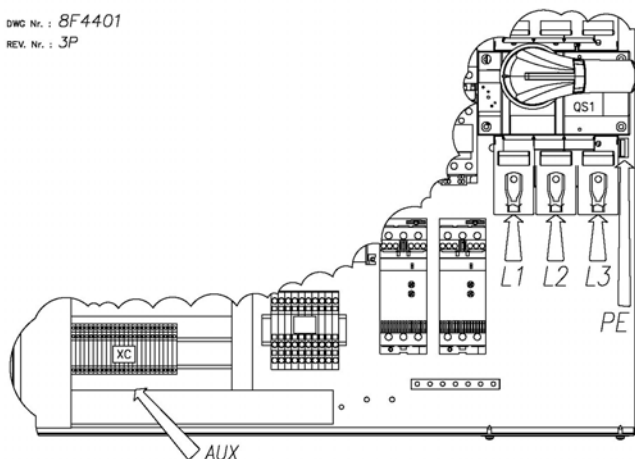

6.5 Connections performed by customer

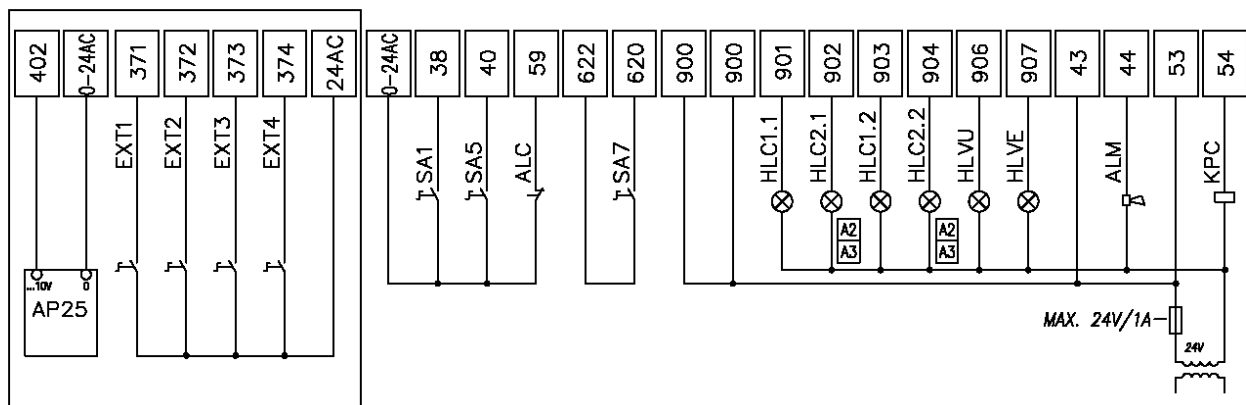

ALC	Free contact from signalling system of fire alarm
ALM	cumulative fault signal
AP25	Modulating extraction module with 0-10V signal
EXT1..4	Ambient extractor potential-free contact
HLC1.1..2.2	Compressor status signal lamp
HLVE	Indicating light of the return and/or supply fan status

HLVU	Indicating light of the supply fan status
KPC	Pump control of the integration coil
SA1	Remote ON/OFF selector
SA5	Settable input
SA7	Enabling selector to the umidifier manual discharge

6.6 SA5 input

SA5: Summer / Winter mode remote change

Summer - winter mode remote change	P008
enabled by SA5*	0
enabled by thermostat	1
enabled by BMS	2
automatic	3
* Fan-only function not available	

function Fan only	P263
disabled	0
enabled by BMS	1
enabled by SA5*	2

*SUMMER - WINTER change mode by SA5 not available

6.7 Wall mounted electronic room control

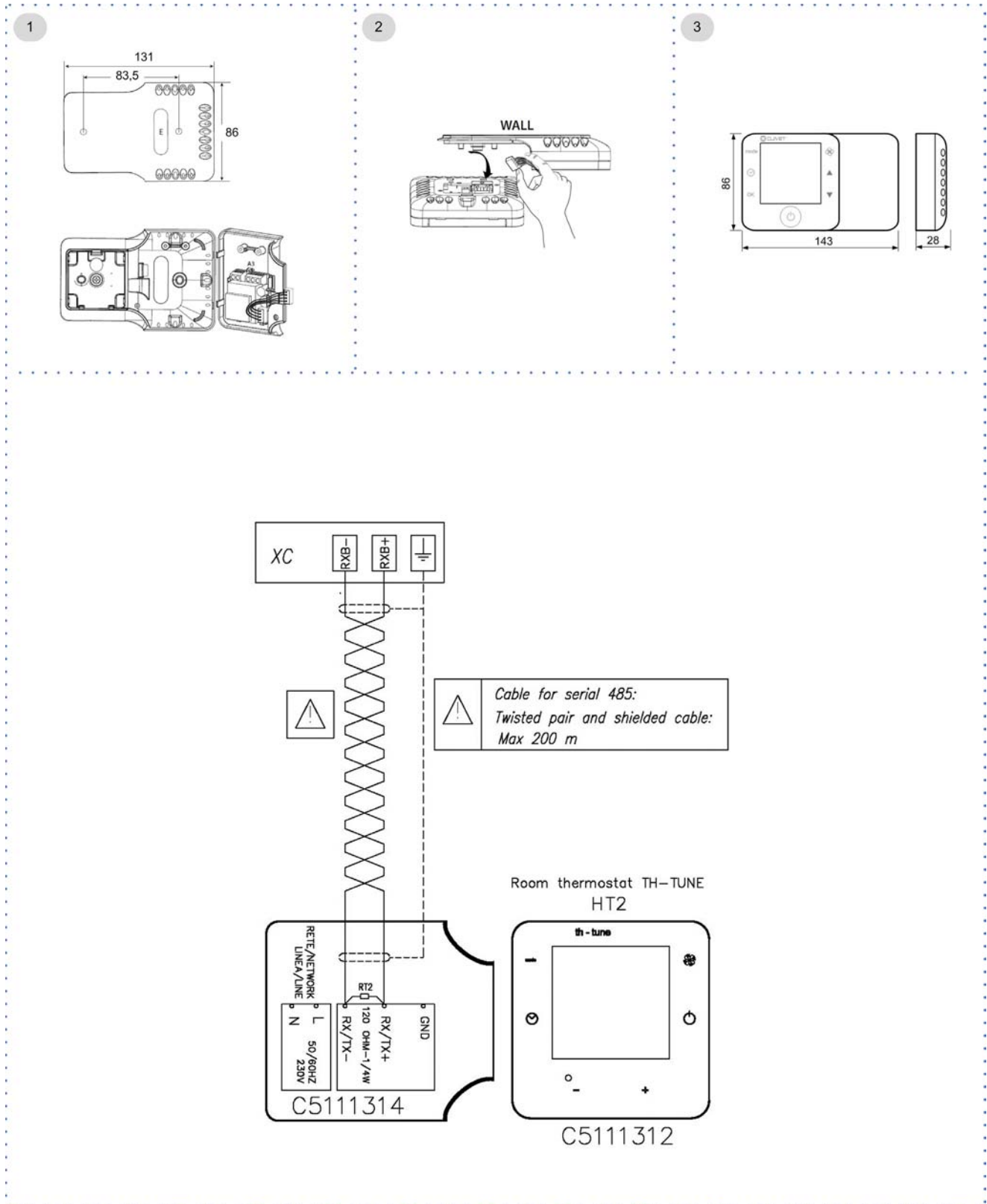

6.8 COMMUNICATION MODULES

Serial communication module for Modbus supervisor

Serial communication module for BACnet supervisor

Serial communication module for LonWorks supervisor

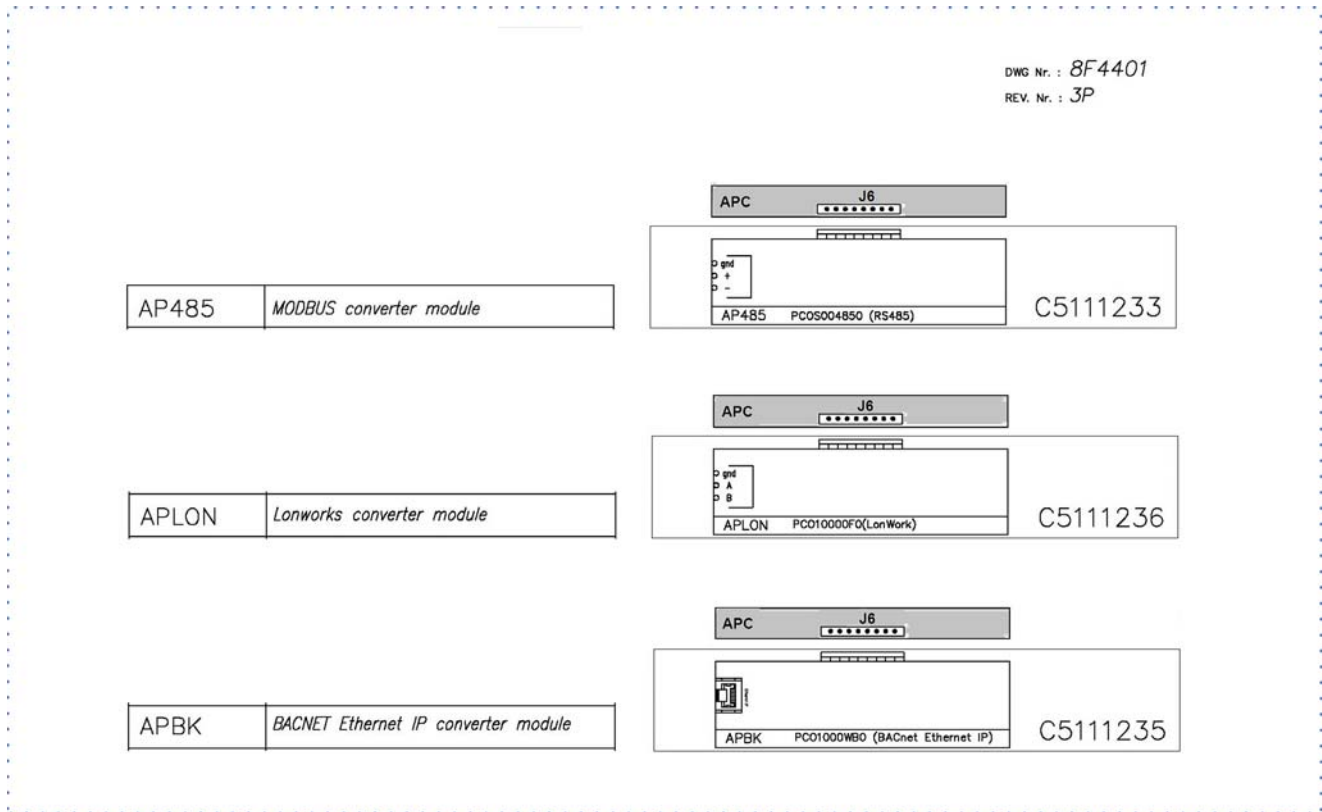

DATA LINE FEATURES

Every RS485 serial line must be set up using the 'In/Out' bus system.

The difference in potential between the earth of the two RS485 devices that the cable shielding needs to be connected to must be lower than 7V

There must be suitable arresters to protect the serial lines from the effects of atmospheric discharges

A 120 ohm resistance must be located on the end of the serial line. Alternatively, when the last serial board is equipped with an internal terminator, it must be enabled using the specific jumper, dip switch or link.

The cable must have insulation features and non-flame propagation in accordance with applicable regulations.

The RS485 serial line must be kept as far away as possible from sources of electromagnetic interference.

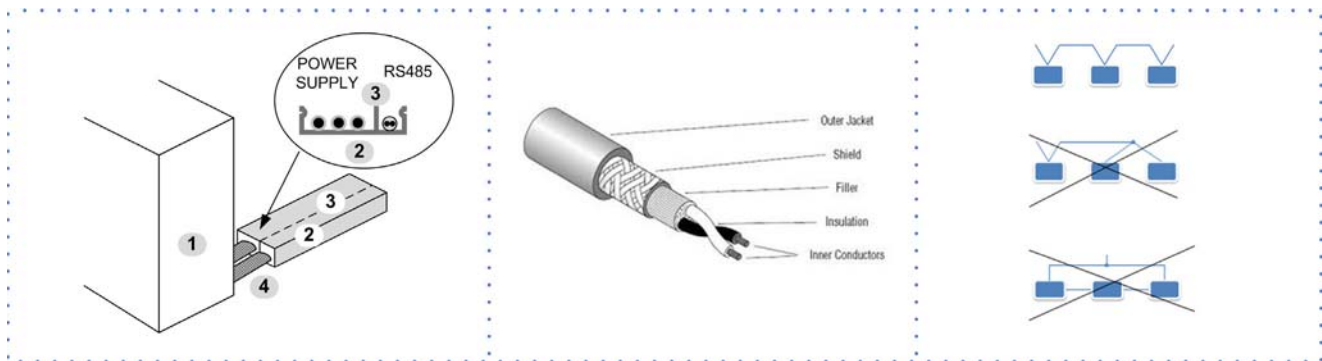

1. Unit
2. Metal conduit

3. Metal septums
4. Metal-lined sheath (sleeve)

7 Start-up

7.1 General description

The indicated operations should be done by qualified technician with specific training on the product.

Upon request, the service centres performing the start-up.

The electrical, water connections and the other system works are by the installer.

Agree upon in advance the start-up data with the service centre.

Before checking, please verify the following:

- the unit should be installed properly and in conformity with this manual
- the electrical power supply line should be isolated at the beginning
- the unit isolator is open, locked and equipped with the suitable warning
- make sure no tension is present



After turning off the power, wait at least 5 minutes before accessing to the electrical panel or any other electrical component.



Before accessing check with a multimeter that there are no residual stresses.

7.2 Preliminary checks

For details refer to the different manual sections.

Unit OFF power supply

1. safety access
2. functional spaces
3. air flow: correct return and supply (no bypass, no stratification)
4. structure integrity
5. fans run freely
6. unit on vibration isolators
7. air filters present and clean
8. completed aeraulic system
9. refrigerant circuit visual check
10. earthing connection
11. power supply features
12. electrical connections provided by the customer

7.3 Start-up sequence

For details refer to the different manual sections.

Unit ON power supply

1. compressor crankcase heaters operating at least since 8 hours
2. off-load voltage measure
3. phase sequence check
4. shut-off valve refrigerant circuit open
5. unit ON
6. load voltage measure and absorptions
7. liquid sight glass check (no bubbles)
8. check all fan operating
9. check air flow on outer coil (no by-pass, no stratification)
10. air flow rate measurement
11. supply, return and outdoor air temperature measurement
12. measure super-heating and sub-cooling
13. check no anomalous vibrations are present
14. climatic curve personalization
15. climatic curve personalization
16. scheduling personalization
17. fire alarm configuration *
18. complete and available unit documentation

* only if present

7.4 Refrigeration circuit

1. Check carefully the refrigerating circuit: the presence of oil stains can mean leakage caused by transportation, movements or other).
2. Verify that the refrigerating circuit is in pressure: Using the unit manometers, if present, or service manometers.
3. Make sure that all the service outlets are closed with proper caps; if caps are not present a leak of refrigerant can be possible.
4. Open the valves of the refrigerant circuit, if there are any.

7.5 Water circuit

1. Before realizing the unit connection make sure that the hydraulic system has been cleaned up and the cleaning water has been drained.
2. Check that the water circuit has been filled and pressurized.
3. Check that the shut-off valves in the circuit are in the "OPEN" position.
4. Check that there isn't air in the circuit, if required, evacuate it using the air bleed valve placed in the system high points.
5. When using antifreeze solutions, make sure the glycol percentage is suitable for the type of use envisaged.



Neglecting the washing will lead to several filter cleaning interventions and at worst cases can cause damages to the exchangers and the other parts.

Weight of glycol (%)	10	20	30	40
Freezing temperature (°C)	-3.9	-8.9	-15.6	-23.4
Safety temperature (°C)	-1	-4	-10	-19

7.6 Electric Circuit



Verify that the unit is connected to the ground plant.

Check the conductors are tightened as: the vibrations caused by handling and transport might cause these to come loose.

Connect the unit by closing the sectioning device, but leave it on OFF.

Check the voltage and line frequency values which must be within the limits: 400/3/50 +/- 10%

Check and adjust the phase balance as necessary: it must be lower than 2%

Example

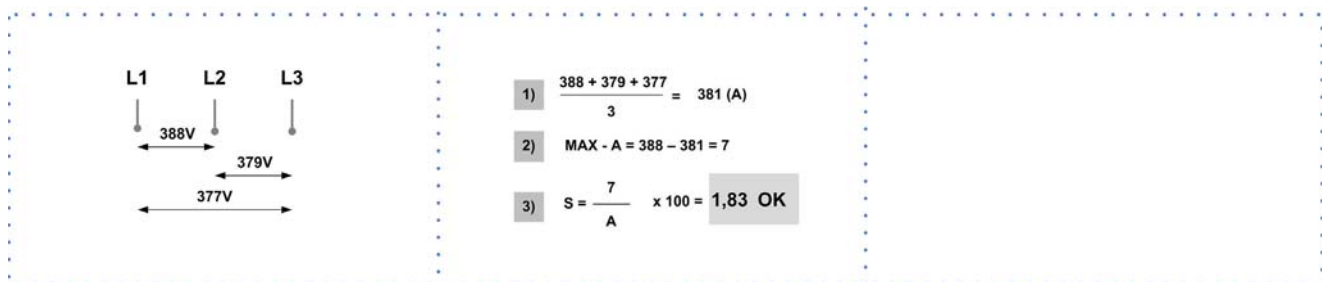

Working outside of these limits can cause irreversible damages and voids the warranty.

7.7 Compressor crankcase heaters

Connect the oil resistances on the compressor crankcase at least 8 hours before the compressor is to be started:

- at the first unit start-up
 - after each prolonged period of inactivity
1. Supply the resistances switching off the unit isolator switch.
 2. To make sure that heaters are working, check the power input.
 3. At start-up the compressor crank-case temperature on the lower side must be higher at least of 10°C than the outside temperature.



Do not start the compressor with the crankcase oil below operating temperature.

7.8 Voltages

Check that the air and water temperatures are within in the operating limits.

Start-up the unit.

With unit operating in stable conditions, check:

- Voltage
- Total absorption of the unit
- Absorption of the single electric loads

7.9 Scroll compressor

The Scroll compressors have only one rotation direction.

In the event it is reversed, the compressor is not immediately damaged, but increases its noise and jeopardises pumping.

After a few minutes, the compressor blocks due to intervention of the thermal protection.

In this case, disconnect power supply and invert 2 phases on the machine power supply.

Avoid the compressor working for a long time with contrary rotation: more than 2-3 of these anomalous start-ups can damage it.

To ensure the rotation direction is correct, measure the condensation and suction pressure.

The pressures must significantly differ: upon start-up, the suction pressure decreases whereas the condensation one, increases.

7.10 Remote controls

Check that the remote controls (ON-OFF etc) are connected and, if necessary, enabled with the respective parameters as indicated in the "electrical connections" section.

Check that probes and optional components are connected and enabled with the respective parameters ("electrical connections" section and following pages).

7.11 Air flow setting

The real unit flow is according to the aeraulic system features.

⚠ Before checking, make sure that the system has been completed in all its parts (shunts, dampers, grilles, diffusers etc.).

⚠ Check the doors and windows of the serviced room are closed.

⚠ Calibration must be carried out with unit all in recirculation.

The unit is in full recirculation during the first 20 minutes from start-up.

Set the flow rate:

par 50 QSetMand (l/sec)

7.12 Air flow management

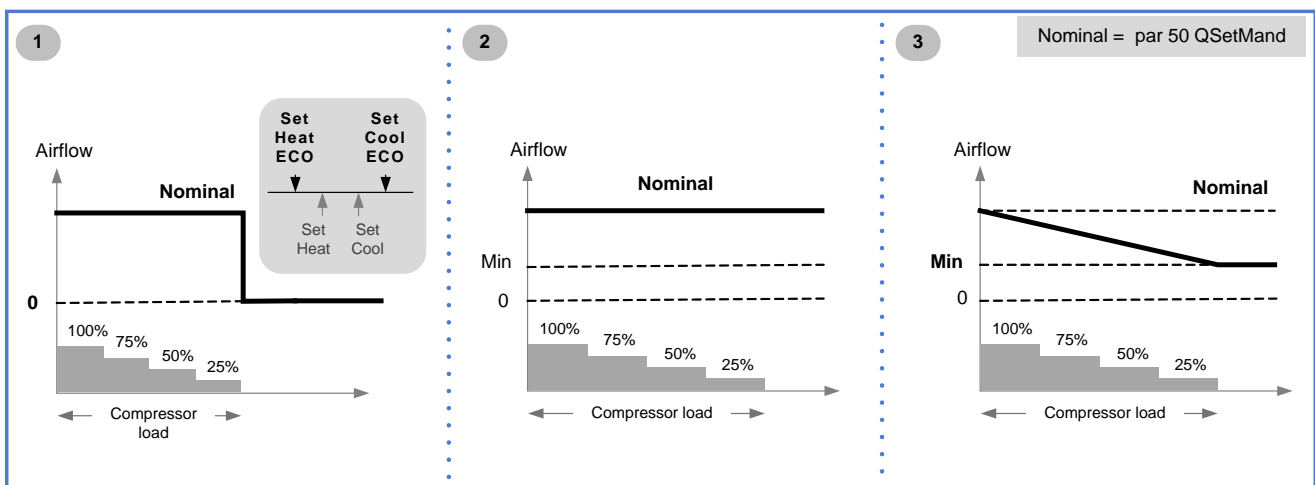

ECO mode

The ECO mode can be activated:

- Manually
- Automatically by the functionality of daily and weekly programming supplied as standard

Standard mode

The air flow supply remains constant in all heat load conditions and operation modes.

Variable airflow

Option

The air flow supply varies depending on the heat load, up to a minimum value compatible with the distribution system and the chosen air diffusion.

The ventilation remains active even when the load is fulfilled (dead zone).

7.13 ECO mode

The air flow supply remains constant at varied heat loads and is shutdown when setpoint is fulfilled.

To further increase the energy savings in this condition, it is also possible to set less demanding operation setpoints for the unit in respect to the standard mode.

This function is indicated for the thermal maintenance of the served area in case it is temporarily not used, which can for example occur at night.

The ECO mode can be activated:

- Manually: P05 Enable EcoMode = 1
- Automatically by means supervision system

Example in cooling mode:

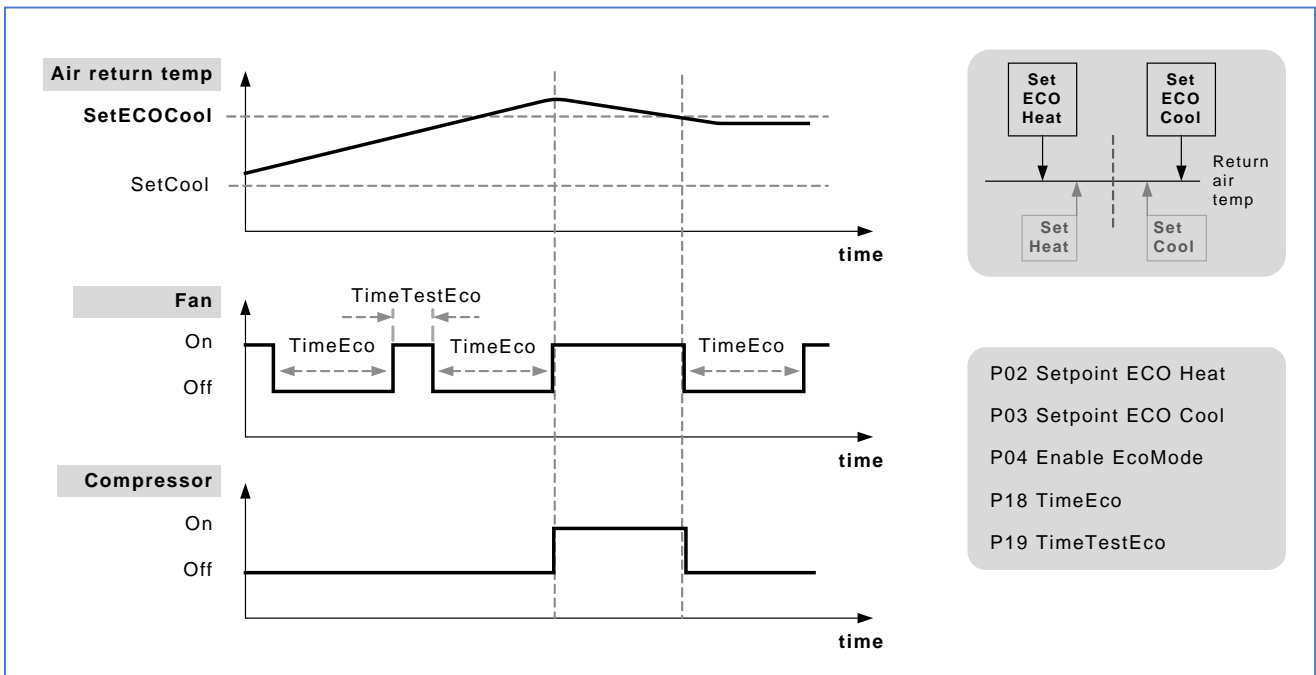

7.14 Set-point automatic compensation

The set changes automatically according to the outside temperature.

Even the operating mode changes automatically according to the outside temperature.

The variation is defined by the climatic curve.

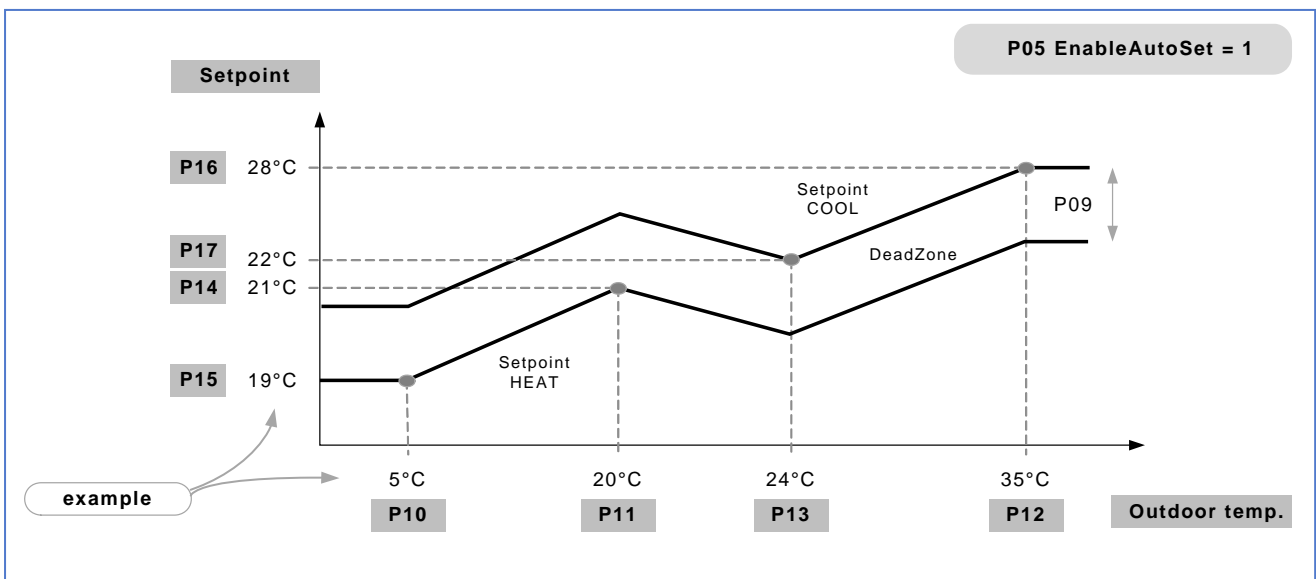

7.15 Room pressure calibration

CCK CCKP configurations

1. check the doors and windows of the serviced room are closed
2. calibration must be carried out with unit all in recirculation
3. on display view the state: S28 Supply differential pressure
4. wait for the pressure value to stabilise and take note of the value
5. to maintain the room in neutral pressure, memorise the detected value in P071 SetPAmb
6. to maintain the room in overpressure, memorise a higher value respect to that detected
7. to maintain the room in depression, memorise a lower value

7.16 Fire alarm: configuration

It is possible to configure the unit behaviour in presence of alarm signal.

Par 151 TypeFireMode

The unit cannot be used as smoke extractor.



Any fire detection devices built-in the unit must be considered as an auxiliary safety system, and, accordingly, must not be a replacement for any fire detection devices in the room.

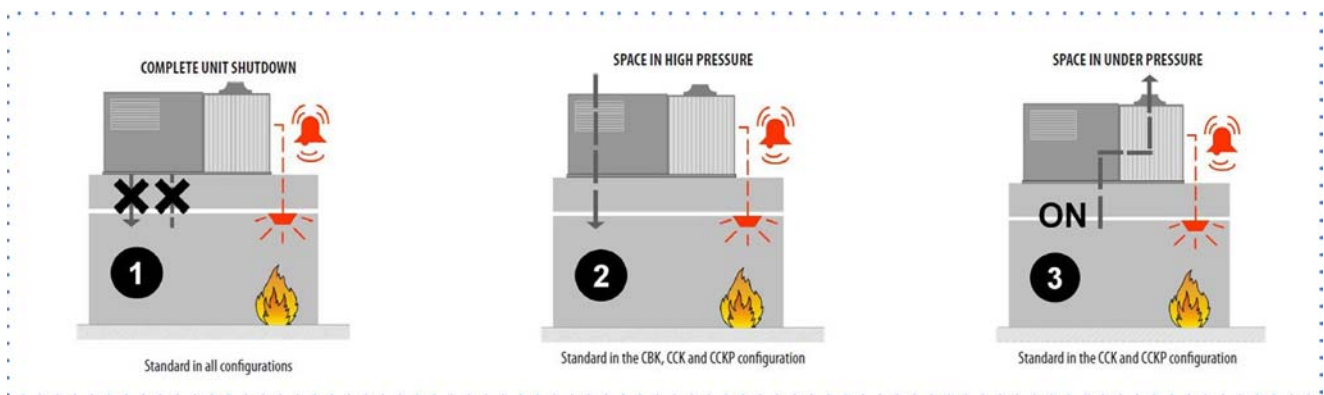

7.17 Textile channels

Option

The operation allows to set the start-up ramp of the supply fan

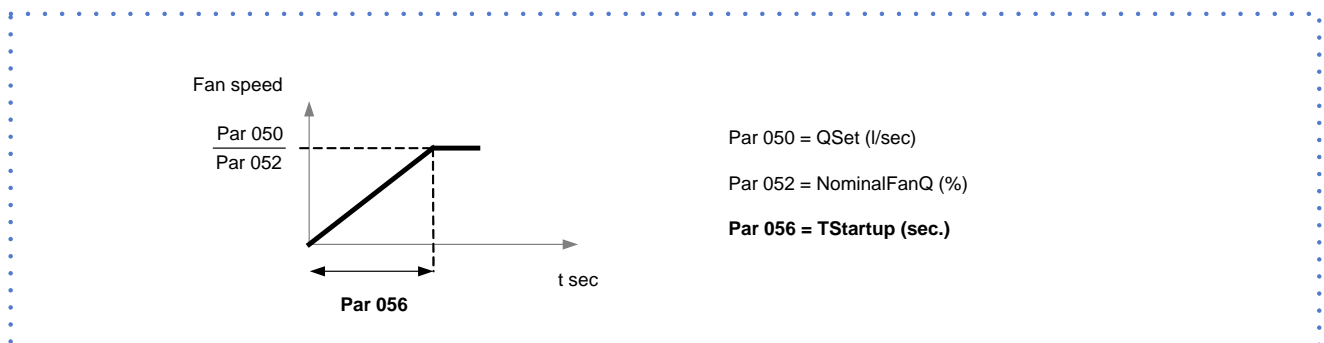

7.18 Application for low outdoor temperature

Option indicated for very cold climates, where the outside temperature can be between -10 and -30°C.

The option includes self-regulating heaters with thermostats that can protect the electrical panel from freezing to make sure it operates correctly.



The accessory is also active with unit OFF; the unit must remain powered.



7.19 Start-up report

Identifying the operating objective conditions is useful to control the unit over time.

With unit at steady state, i.e. in stable and close-to-work conditions, identify the following data:

- total voltages and absorptions with unit at full load
- absorptions of the different electric loads (compressors, fans, pumps etc)
- temperatures and flows of the different fluids (water, air) both in input and in output from the unit
- temperature and pressures on the characteristic points of the refrigerating circuit (compressor discharge, liquid, intake)

The measurements must be kept and made available during maintenance interventions.

7.20 2014/68/UE PED directive

DIRECTIVE 2014/68/UE PED gives instructions for installers, users and maintenance technicians as well.

Refer to local regulations; briefly and as an example, see the following:

Compulsory verification of the first installation:

- only for units assembled on the installer's building site (for ex. Condensing circuit + direct expansion unit)

Certification of setting in service:

- for all the units

Periodical verifications:

- to be executed with the frequency indicated by the Manufacturer (see the "maintenance inspections" paragraph)









8 - CONTROL















SETPOINT

the display visualizes the **ambient temperature**

1. Press once ▲ or ▼ to display the setpoint (it appears on the display ^{set})
2. press ▲▼ to modify the working setpoint
3. Wait that the ambient temperature appears again on the display (disappears ^{set})

KEY FUNCTION	
	ON-OFF Press 5 seconds to access or switch off the unit.
mode	MODE Change the operating mode : summer, winter, automatic
	CLOCK Date and hour control
OK	OK Confirm, display setpoint, display the outside temperature (tE)
 	UP-DOWN Shift in the menu, increase-decrease the value
 + 	5 sec Access to the password menu (Code)
mode + 	5 sec Access to the alarm menu ; only if the  icon is present

DISPLAY MEANING	
	Operating mode : summer
	Operating mode : winter
	Operating mode : automatic
	supply fan speed
	alarm
	Keyboard locked
	Time band activated
	Time band scheduling
	Active compressor
	Defrosting in progress
	External fan
	electric heaters , hot water coil - option

8 - CONTROL

ON / OFF

 Press for 5 seconds





OFF



MODE CHANGE

Press to set the operating mode:



mode  Cooling

 Heating

AUTO Automatic

Operating in:

 Cooling





BUTTON LOCK / UNLOCK

 Press together for 5 seconds

OK





 Symbol appears



ON / OFF SCHEDULING

 Press for deactivate or enable the scheduling.



The deactivated scheduling, the symbol  doesn't appear



DAY MODIFICATION

- Press the **CLOCK** button for 5 sec.
- By the **▲ ▼** buttons, select the **clock** menu
- Confirm with **OK**
- The hour is flashing : set with the **▲ ▼** buttons
- Confirm with **OK**
- Repeat the procedure for the minutes and week's day
- To go back to the main screen, select the **Esc** menu and confirm with **OK**

PARAMETERS

The setting parameters are protected by password to avoid inadvertent changes that can affect the unit operating.

To access to the parameters

1. press **On/Off + Fan** button for 5 sec.
2. enter password : with the **▲ ▼** button set **Code = 2**
3. Confirm with **OK**
4. Select the **PAR** menu and confirm with **OK**
5. Scroll the list **▲ ▼**
6. Select the parameter with **OK**
7. Modify the value **▲ ▼** and confirm with **OK**
8. To esc, scroll the lost, select **ESC** and confirm with **OK**

P02	SetPoint eco heat mode
P03	SetPoint eco cool mode
P04	Enable Setpoint Eco
P05	Enable Setpoint Auto
P06	Set CO2
P200	Enable alarm buzzer : 0 = disabled, 1= enabled

TIME BAND SCHEDULING

It is possible to set 4 types of scheduling:

- 7 days (from monday to sunday)
- 5 days (from monday to friday)
- 2 days (from saturday to sunday)
- Day by day

Day scheduling



At home



Outside



Return to home

Night scheduling



At home



Outside the home



Return to the home

Day by day scheduling



Press for 5 seconds



Select Time bands



Press OK



Select the scheduling:



- Day by day

Press OK



Press OK

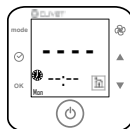

Set the hour



Press OK



Set the minutes



Press OK



Set the temperature



Press OK



Select the next time band

Press OK and repeat from **point 05**

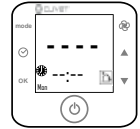

As all the programming is finished, select ESC



Press OK



Press OK to program the next day



Select the next day



Press OK

Repeat from **point 04**



To exit from the scheduling select ESC



Press OK



Select Esc to exit



Press OK



ALARMS

Malfunctions are displayed with the ALARM icon.



Before resetting an alarm, identify and remove the cause that generated it.

Repeated reset may cause irreversible damages as a system malfunction.















The alarm can be signalled by the thermostat also by a buzzer.

To disable the buzzer, modify the P200 parameter.
(0 = disabled)

ALARM RESET

<p>mode The symbol is displayed </p> <p> Press together for 5 seconds</p>	
<p> </p> <p>Scroll the list</p>	
<p> </p> <p>Select the alarm reset menu</p> <p>Press OK</p>	
<p> </p> <p>Select ESC</p> <p>Press OK</p>	

STORED ALARM (installer use only)

<p> </p> <p>Press buttons for 5 sec</p>	
<p> Enter password</p> <p> Confirm with OK</p>	
<p> Select S ALM</p> <p> Confirm with OK</p>	
<p> </p> <p>Scroll alarm list (AL1, AL2...) and display alarm detail</p>	
<p>1° alarm - 1° display</p> <p>AL1 new alarm</p> <p>XX alarm code (STD column pag. 20)</p>	
<p>1° alarm - 2° display</p> <p>dA1 alarm day 1</p> <p>YY day number after alarm</p>	
<p>1° alarm - 3° display</p> <p>HA1 alarm hour 1</p> <p>hhmm</p>	

LIST OF ALARMS		
Stor	CODE	Description
100	AE01	Alarm of faulty return temp. probe
101	AE02	Alarm of faulty supply temp. probe
102	AE03	Alarm of faulty outside temp. probe
103	AE04	Alarm of faulty coil probe temp. probe circuit 1
104	AE05	Alarm of faulty differential pressure probe of the supply fan
105	AE06	Alarm of faulty condensing pressure probe circuit 1
106	AE07	Alarm of faulty evaporating pressure probe circuit 1
107	AE08	Alarm of faulty return temp. probe circuit 1
108	AE09	Alarm of faulty antifreeze probe temp. probe of the additional coil
109	AE10	Alarm of faulty air quality probe
110	AE11	Alarm of faulty ext. RH probe
111	AE12	Alarm of faulty return RH probe
112	AE13	Alarm of faulty diff. Detector of the fresh/ambient air
113	AE14	Alarm of faulty ambient thermostat temp. probe
114	AE15	Alarm of faulty ambient thermostat RH%
200	AE20	pCOE communication alarm
201	AE21	Alarm of the humidifier communication
202	AE22	Alarm of ambient thermostat communication
203	AE23	Alarm of supply fan overload (cond. fan/pump) or compartment opening or supply flow alarm
204	AE26	Circuit 1 overload alarm
206	AE28	Phase monitor alarm
207	AE29	Alarm of faulty coil probe temp. probe circuit 2
208	AE30	Alarm of faulty condensing pressure probe circuit 2
209	AE31	Alarm of faulty evaporating pressure probe circuit 2
210	AE32	Alarm of faulty return temp. probe circuit 2
211	AE33	Circuit 2 overload alarm
115	AE35	Faulty hydronic recovery temperature probe
600	AE36	Alarm of faulty outside temp. from serial probe
601	AE37	Alarm of faulty external RH from serial probe
602	AE38	Alarm external serial probe offline
214	AE39	Electronic filters alarm
213	AE40	Alarm gas burner module
215	AE41	Alarm offline board Pcoe adr 5
603	AE42	Alarm analogic signal ExpFlow

LIST OF ALARMS		
Stor	CODE	Description
300	AF01	HP alarm of the refrigerant circuit circuit 1
301	AF02	LP alarm of the refrigerant circuit circuit 1
302	AF03	HP1 high pressure prealarm circuit 1
303	AF04	LP1 low pressure prealarm circuit 1
304	AF05	HP2 high pressure prealarm circuit 1
305	AF06	LP2 low pressure prealarm circuit 1
306	AF07	HP alarm of the refrigerant circuit circuit 2
307	AF08	LP alarm of the refrigerant circuit circuit 2
308	AF09	HP1 high pressure prealarm circuit 2
309	AF10	LP1 low pressure prealarm circuit 2
310	AF11	HP2 high pressure prealarm circuit 2
311	AF12	LP2 low pressure prealarm circuit 2
400	AA01	Fire alarm
401	AA02	Dirty filter warning
402	AA03	Resistance high temperature alarm
500	AI01	Source water flow-rate alarm circuit 1
501	AI02	Antifreeze alarm of the source exchanger
502	AI03	Antifreeze alarm hot water coil
505	AI04	Source water flow-rate alarm circuit 2
506	AI05	Antifreeze alarm of the source exchanger
503	AI10	Humidifier alarm group 1
504	AI11	Humidifier alarm group 2

STATA

To access to the stata:

1. Press the On/Off + Fan button for 5 sec.
2. Enter the password: with ▲ ▼ buttons, set **Code = 1**
3. Confirm with **OK**
4. The **Sta** menu appears, confirm with **OK**
5. Scroll the list of stata with ▲ ▼ buttons
6. To esc scroll the list, select **ESC** and confirm with **OK**

S01	ManSet	°C
S02	SetUR	%
S03	Request of total Vc capacity	%
S04	Capacity request to compressors	%
S05	Capacity delivered from free cooling/heating	%
S06	Capacity requested to the aux. element	%
S07	N. of active compressors	-
S08	Ext. damper opening	%
S09	Exhaust fan modulation	%
S10	Return air differential pressure	Pa
S11	Additional element modulation (electric resistances / hot water coil)	%
S12	Operative return temperature	°C
S13	Supply temperature	°C
S14	Operative ambient RH%	%
S15	CO2 probe	Ppm
S16	Fresh air temperature	°C
S17	Fresh air RH%	%
S18	Temperature of the coil probe/source exchanger circ.1	°C
S19	Temperature of the aux. element antifreeze probe	°C
S20	Condensing pressure circuit 1	Bar
S21	Evaporating pressure circuit 1	Bar
S22	Condensing fan signal circuit 1	%
S23	Return temperature circuit 1	°C
S24	Current overheating circuit 1	°C
S25	Thermostatic valve opening circuit 1	%

S26	Supply air flow	m3/h*10
S27	Signal of modulating supply fan	%
S28	Supply differential pressure	Pa
S29	Modulating humidifier signal	%
S31	Functionning compressor 1 hours	
S32	Functionning compressor 2 hours	
S33	Compressor 1 starts	
S34	Compressor 2 starts	
S35	Software type	
S36	Software version number	
S37	Software release day	
S38	Software release month	
S39	Software release year	
S40	Temperature of the coil probe/source exchanger circ.2	°C
S41	Condensing pressure circuit 2	Bar
S42	Evaporating pressure circuit 2	Bar
S43	Condensing fan signal circuit 2	%
S44	Return temperature circuit 2	°C
S45	Current overheating circuit 2	°C
S46	Thermostatic valve opening circuit 2	%
S47	Inlet temperature recovery	°C
S48	Supply air flow	l/s
S49	Functionning hours compressor 1 circuit 2	ore
S50	Functionning hours compressor 2 circuit 2	ore
S51	Starts compressor 1 circuit 2	-
S52	Starts compressor 2 circuit 2	-
S53	Inlet signal % ExFlow =5	V
S54	Number extractor on (con 0<P_EnExFlow<5)	-

9 Maintenance

9.1 General description

Maintenance must be done by authorized centres or by qualified personnel.

The maintenance allows to:

- maintain the unit efficiency
- increase the life span of the equipment
- assemble information and data to understand the state of the unit efficiency and avoid possible damages

Before checking, please verify the following:

- the electrical power supply line should be isolated at the beginning
- the unit isolator is open, locked and equipped with the suitable warning
- make sure no tension is present



After turning off the power, wait at least 5 minutes before accessing to the electrical panel or any other electrical component.



Before accessing check with a multimeter that there are no residual stresses.

9.2 Inspections frequency

Perform an inspection every 6 months minimum.

The frequency, however, depends on the use.



In the event of frequent use it is recommended to plan inspections at shorter intervals:

- frequent use (continuous or very intermittent use, near the operating limits, etc)
- critical use (service necessary)

√	intervention frequency (months)	1	6	12
1	presence corrosion			X
2	panel fixing			X
3	fan fixing		X	
4	coil cleaning		X	
5	bowl cleaning + sanitisation		X	
6	outflow test		X	
7	air filters cleaning / inspection	X		
8	check of the fixing and the insulation of the power lead			X
9	check of the earthing cable			X
10	electric panel cleaning			X
11	capacity contactor status			X
12	termina closing, cable insulation integrity			X
13	voltage and phase unbalancing (no load and on-load)		X	
14	absorptions of the single electrical loads		X	
15	test of the compressor crankcase heaters		X	
16	Checking for leaks			*
17	survey of the refrigerant circuit operating parameters		X	
18	safety valve			*
19	protective device test: pressure switches, thermostats, flow switches etc..		X	
20	control system test: setpoint, climatic compensations, capacity stepping, water / air flow-rate variations		X	
21	control device test: alarm signalling, thermometers, probes, pressure gauges etc..		X	

* Refer to the local regulations; and ensure correct adherence. Companies and technicians that effect interventions of installation, maintenance/repairs, leak control and recovery must be CERTIFIED as expected by the local regulations. The leak control must be effected with annual renewal.

9.3 Unit booklet

It's advisable to create a unit booklet to take notes of the unit interventions.

In this way it will be easier to adequately note the various interventions and aid any troubleshooting.

Report on the booklet:

- date
- intervention description
- carried out measures etc.

9.4 Standby mode

If a long period of inactivity is foreseen:

- turn off the power
- avoid the risk of frost (empty the system or add glycol)

Turn off the power to avoid electrical risks or damages by lightning strikes.



With lower temperatures keep heaters turned on in of the electrical panel (option).

It's recommended that the re-start after the stopping period is performed by a qualified technician, especially after seasonal stops or seasonal switching.

When restarting, refer to what is indicated in the "start-up" section.

Schedule technical assistance in advance to avoid hitches and to guarantee that the system can be used when required.

9.5 Electric fans

Check:

- the fans and the relative protection grids are well fixed
- the fan bearings (evident by noise and anomalous vibrations)
- the terminal protection covers are closed and the cable holders are properly positioned

9.6 Outdoor air coil



Contact with the exchanger fins can cause cuts: wear protective gloves to perform the above described operations.

It is extremely important that the battery gives the maximum thermal exchange; therefore, its surface must be cleaned from dust and deposits.

Remove all impurities from the surface.

Using an air pressure gun, clean the aluminum surface of the battery; be careful to direct the air in the opposite direction of the fan air movement.

Hold the gun parallel to the fins to avoid damages.

As an alternative, vacuum cleaner can be used to suck impurities from the air input side.



Verify that the aluminum fins are not bent or damaged, in the event of damages contact the authorized assistance center and get the fins straightened in order to restore the initial condition for an optimal air flow.

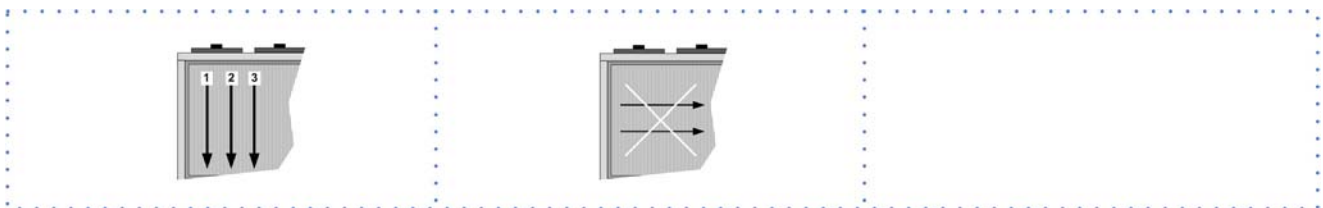

9.7 Outdoor air coil



Contact with the exchanger fins can cause cuts: wear protective gloves to perform the above described operations.

The finned surfaces of the cooling coils and, in particular, the condensate collection bowls constitute places where microorganisms and moulds greatly flourish.

It is very important to foresee periodical cleaning with suitable detergents and, eventually, disinfect with sanitising products.

9.8 Condensation collection basin

Dirt or scale can give rise to clogging.

Also, microorganisms and mould can flourish in the bowl.

It is very important to foresee periodical cleaning with suitable detergents and, eventually, disinfect with sanitising products.

Once cleaning is completed, pour water inside the bowl to check the regular outflow.

9.9 Compressor supply line shut-off valve

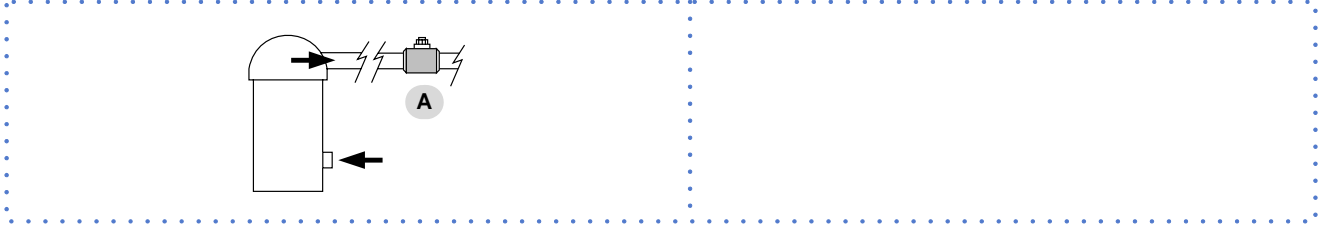

A. Supply line shut-off valve



Do not remove the seal

Remove only if authorized by the manufacturer.

Please contact the maker for informations.

9.10 crankcase heater

Check:

- closure
- Operation

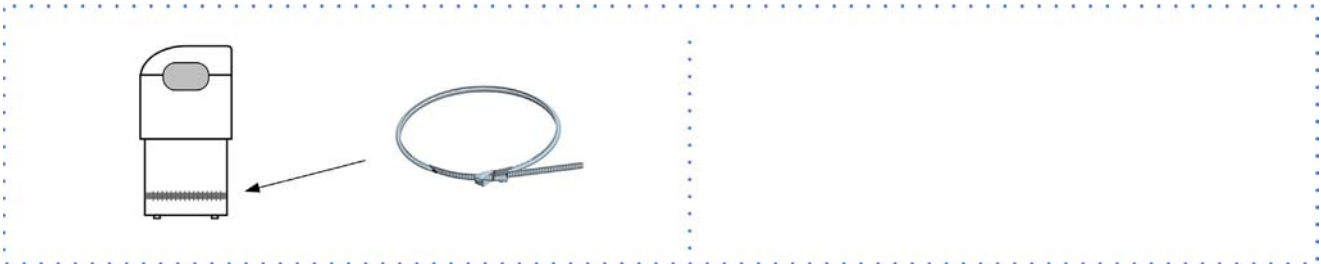

9.11 Copeland scroll compressor

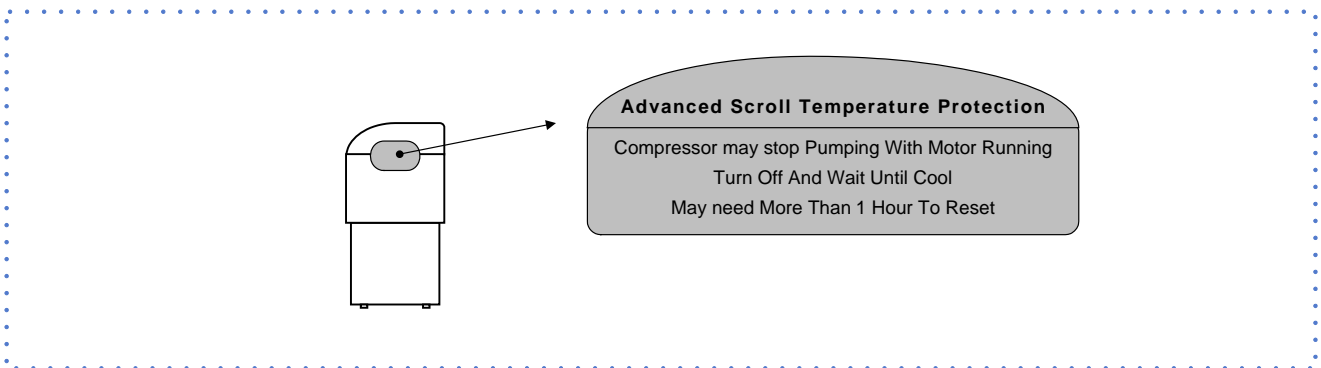

9.12 G4 Folded air filters

It is very important for the air treatment coil to offer maximum thermal exchange: the unit must always work with clean and installed filters. Cleaning and replacement of filters are very important from an hygienic-sanitary point of view.

⚠ Operation with clogged filters leads to a reduction in the air flow rate with malfunctionings and block, up to possible breaks in the unit. The frequency with which the filters must be checked depends on the quality of the air, the unit operation hours, the dustiness and crowding of rooms.

⚠ Frequency can indicatively vary from WEEKLY to MONTHLY.

⚠ It is advised to start with frequent checks, subsequently adjusting frequency to degree of detected dirt.

1. Remove the closing panels
2. Delicately remove the filter avoiding dirtying the area below
3. Wash the filtering jacket in warm water with common detergent
4. Accurately rinse in running water avoiding spilling in the room
5. Dry the filter
6. Insert it back in its seat
7. Remount the closing panels

Old filters, washing wastewater and residues must be disposed of according to the current standards.

9.13 F7 Highly efficient filters

For details see:

10 Accessories p. 33

9.14 Electronic filters

For details see:

10 Accessories p. 33

9.15 Wall mounted electronic room control

In the maintenance operations the keypad can be detached from the fixing support and directly connected to the unit electrical panel.

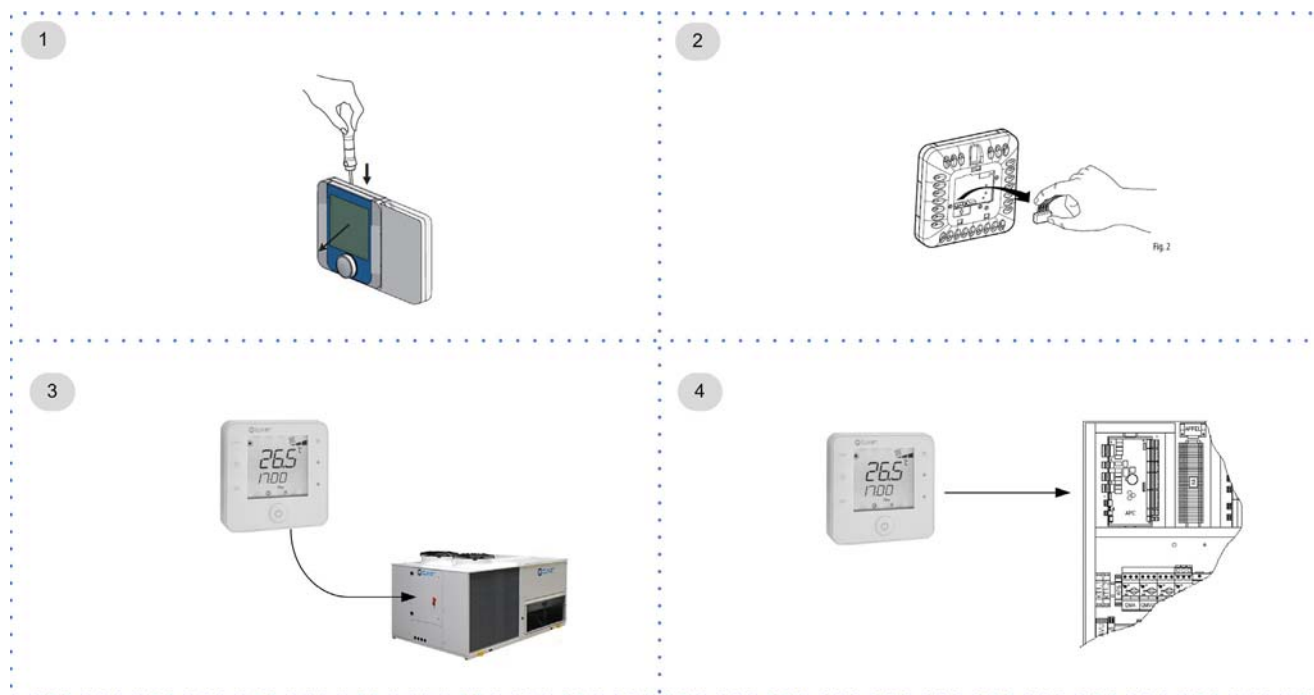

9.16 Immersed electrode humidifier

For details see:
10 Accessories p. 33

9.17 Heater humidifier

For details see:
10 Accessories p. 33

9.18 Electric heaters

Accessory

Check:

- cleaning state
- fastening
- presence of corrosion

10 Accessories

10.1 Configurations

- CAK Configuration with single fan section for full recirculation
- CBK Configuration with single fan section for recirculation and fresh air
- CCK Configuration with double fan section for recirculation, fresh and exhaust air
- CCKP Configuration with double fan section with fresh air and THOR thermodynamic recovery

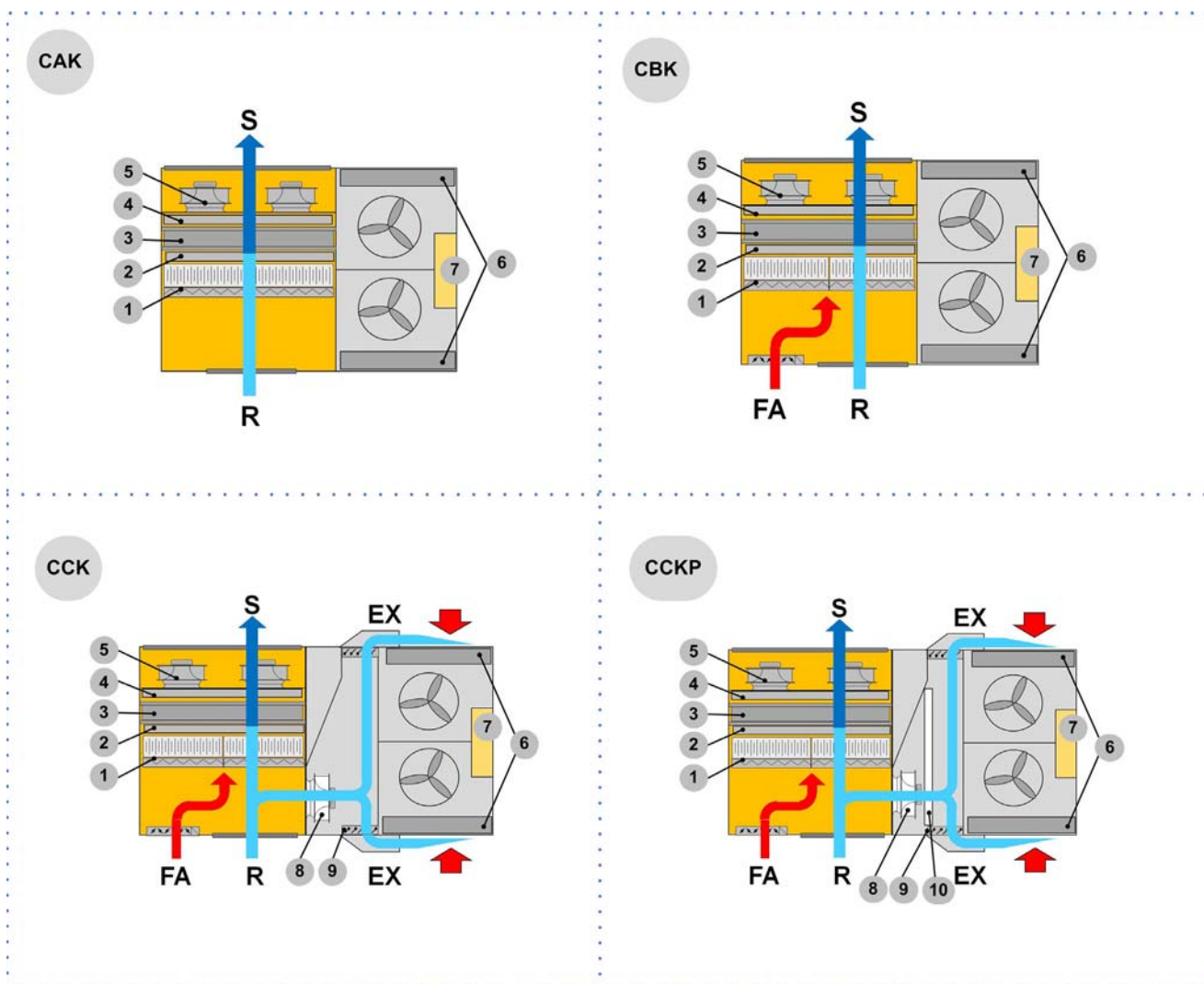

1. G4 efficiency filters + H10 equivalent electronic filters
2. Hot water exchanger or electric heaters
3. Handling exchanger
4. Hot gas reheating exchanger
5. Return + supply fan section

R Return air
S Supply air

6. Source side exchanger
7. Electrical panel
8. Exhaust fan
9. Overpressure damper
10. Thermodynamic recovery exchanger, THOR

FA Fresh air
EX Exhaust air

10.2 Electronic filters

The most common contaminants for which the filter is designed, are: air pollution by PM10, PM 2,5 and PM1

Contaminants that can be filtered:

- dry smokes
- powder (up to 0,3 microns)
- smoke electrostatically charged



Contaminants that can NOT be filtered:

- water vapors also in low concentration
- oil vapors
- large amounts of dust
- metal shavings, iron filing dusts and waste generally
- Gas



Absolutely to avoid:

- metal dusts also fine
- fumes produced by combustion of organic and not materials (wood, coal, gasoline, etc.)

MATERIALS NECESSARY FOR MAINTENANCE

- Plastic or steel tank (750x750x310 mm) with settling bottom
- Acid detergent B01212 (code CLIVET C6460316)
- Protective gloves and goggles
- Graduated jug
- Pump for manual or pneumatic spraying



Do not use aluminum tanks or galvanized

Foresee a stainless steel frame that keeps the filters lifted from the tank base to have a settling bottom for the muds.

The electronic adjustment is integrated in the filter; maintenance can be carried out without removing it.

Remove the pre-filter by lifting it of about 1 cm and remove it as shown in figure.

1. Position the filter to be washed on a support to facilitate work.
2. Prepare a tank with a solution of B01212 detergent and water at 1÷20.
3. Immerse the filter in this solution.
4. Ensure the solution covers the entire filter.
5. A slight chemical reaction is noticed within 2÷3 minutes with the development of foam. Wait 3 or 4 minutes.
6. Rinse the filter with a jet of water or using a low-pressure water jet machine.
7. Leave the electrostatic cells to dry in a hot room or directly in the sun for a few hours. Keep the cells lifted from the ground using two metal or wooden laths.
8. Check the ionisation wires before remounting the filter.

The cleaner can be used to clean about 20 filters.

Can be recovered and placed in plastic containers closed; the air oxidizes the cleaner and reduces its effectiveness.

IONISATION WIRES

The impurities can determine oxidation or scaling on the wires, which can be removed using a cloth soaked in alcohol or an abrasive scourer with very fine grain.

Due to the high voltage powering them, the ionisation wires are subject to wear.

To foresee a yearly replacement OF ALL WIRES avoids unexpected breaks.

In case of break:

1. remove all wire pieces present in the cell and remove the springs stretching the wire
2. hook the spring to the wire eyelet
3. grip the ionisation wire with curved beaks pliers
4. hook the top of the spring with the open eyelet to the wire stretcher rod of the electrostatic cell
5. keeping the ionisation wire stretched, with the other hand hook it to the other wire stretching rod, always by means of the curved beaks pliers

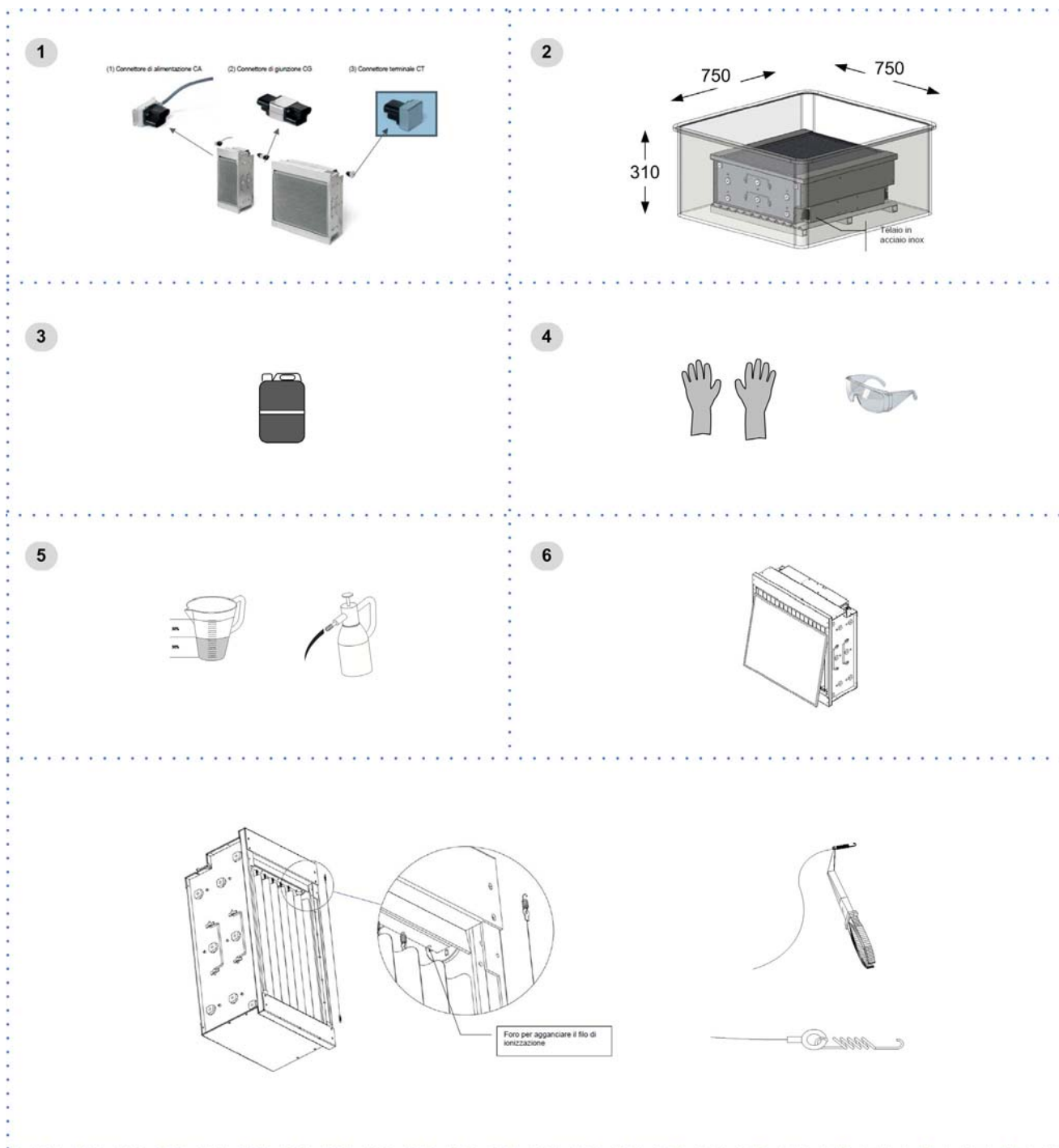

10.3 F7 Highly efficient filters

Accessory

The pocket filters are not renewable, once dirty they must be replaced

1. Open the access panel
2. Delicately remove the filter avoiding dirtying the area below
3. Insert the new filters, with the pockets vertically
4. Close the panel
5. Dispose of the old filters sending them to specialised recycling or collection centres (keep to the standards in force)

10.4 Immersed electrode humidifier

SUPPLY WATER

The humidifier must be supplied with mains water having the following features:

- pressure between 0.1 and 0.8 Mpa (1 – 8 bar)
- temperature between 1 and 40°C

Do not use:

- water treated with softeners: it can corrode the electrodes and form foam with possible faults/malfunctionings
- pit, industrial or potentially polluted (chemically or bacteriologically) water
- disinfectants or anti-corrosive substances mixed with water, as potentially irritating

Supplying the humidifier with water treated with reverse osmosis filtering system gives the following advantages:

- reduces limescale deposits
- reduces energy consumptions
- reduces maintenance costs
- increases humidifier duration

Check that the filter guarantees a water flow rate higher than the flow rate of the installed humidifier.

DRAINAGE WATER

It can reach a temperature of 100°C

It contains the same substances of the supply water but in higher concentration.

As it is not toxic, it can be disposed of with white waters.

Limit values for the supply water with medium-high conductivity in an immersed electrode humidifier			
		min	max
Hydrogen ions	pH	7	8,5
Specific conductivity at 20°C	µS/cm	300	1250
Total dissolved solids	TDS mg/l ⁽¹⁾	⁽¹⁾	⁽¹⁾
Dry residue at 180°C	R ₁₈₀ mg/l ⁽¹⁾	⁽¹⁾	⁽¹⁾
Total hardness	TH mg/l CaCO ₃	100 ⁽²⁾	400
Temporary hardness	mg/l CaCO ₃	60 ⁽³⁾	300
Iron + Manganese	mg/l Fe+Mn	0	0,2
Chlorides	ppm Cl	0	30
Silica	mg/l SiO ₂	0	20
Residual chlorine	mg/l Cl ₂	0	0,2
Calcium sulphate	mg/l CaSO ₄	0	100
Metallic impurities	mg/l	0	0
Solvents, diluents, soaps, lubricants	mg/l	0	0

Limit values for the supply water with medium-low conductivity in an immersed electrode Humidifier			
		min	max
Hydrogen ions	pH	7	8,5
Specific conductivity at 20°C	µS/cm	125	500
Total dissolved solids	TDS mg/l ⁽¹⁾	⁽¹⁾	⁽¹⁾
Dry residue at 180°C	R ₁₈₀ mg/l ⁽¹⁾	⁽¹⁾	⁽¹⁾
Total hardness	TH mg/l CaCO ₃	50 ⁽²⁾	250
Temporary hardness	mg/l CaCO ₃	30 ⁽³⁾	150
Iron + Manganese	mg/l Fe+Mn	0	0,2
Chlorides	ppm Cl	0	20
Silica	mg/l SiO ₂	0	20
Residual chlorine	mg/l Cl ₂	0	0,2
Calcium sulphate	mg/l CaSO ₄	0	60
Metallic impurities	mg/l	0	0
Solvents, diluents, soaps, lubricants	mg/l	0	0

(¹) Values depending on specific conductivity; in general: TDS ≅ 0,93 * σ₂₀; R₁₈₀ ≅ 0,65 * σ₂₀
(²) not lower than 200% of the chloride content in mg/l of Cl
(³) not lower than 300% of the chloride content in mg/l of Cl

Periodical checks

Do not use solvents or detergents to clean the plastic components.

For descaling use a vinegar or acetic acid solution at 20%, subsequently rinsing with water.

15 days	Cylinder: not over 300 hours of work checking operation, general state, no leaks
90 days	Cylinder: not over 1000 hours of work checking operation, general state, no leaks, any replacement
1 year	Cylinder: not over 2500 hours of work (disposable cylinders) Load solenoid valve replacement: disconnect electric power supply, dismantle valve, clean the filter Drain solenoid valve: disconnect electric power supply, remove reel and dismantle valve body and any impurity and rinse The power supply bowl, piping: check they are free and without impurities
5 years	Cylinder: not over 10000 hours of work (inspectional cylinders) replacement

Humidifier cylinder drainage

Cylinder must be drained in these situations:

- cleaning of the cylinder
- emptying of the cylinder to avoid ice forming
- replacement of the cylinder

The manual drainage is carried out by means of selector SA7: see ELECTRIC CONNECTIONS chapter.

Replacement of the cylinder

To remove the cylinder:

- completely drain the water
- interrupt power supply voltage of humidifier by means of the unit isolator
- remove the vapour pipe from the cylinder
- disconnect the electric connections of the electrodes and remove the pins from the high level electrodes
- loosen the ring nut to remove the pipe unions and the filter (when filter is outside the cylinder)
- lift the cylinder to remove it

Before mounting it:

- the filter body does not require replacing, wash it with water and remount it on the new cylinder, using the new gasket provided with the latter
- check the seal gasket between the cylinder and the drain unit
- remount the cylinder repeating the operations in reverse order

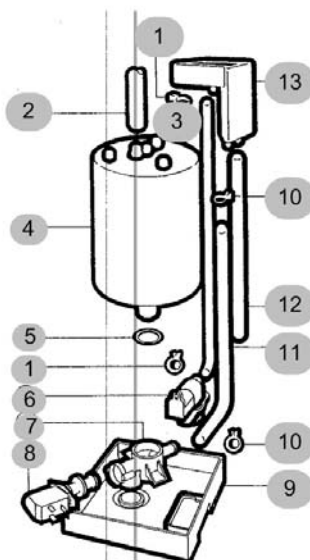

10.5 Modulating condensation gas heating module

System maintenance booklet

- It must be kept in the place of installation of the unit
- It must be filled-in upon commissioning
- It must be updated with the results of the periodical checks, of the routine and extraordinary maintenance interventions.

Gas connection

- Read the gas heating module manual.
- Connection must be carried out by qualified personnel.
- use certified components and comply with the local standards in force
- install on the gas connection: cock, large section filter and anti-vibration joint
- check the supply pressure is correct and stable, in particular where more uses are inserted on the same line.

The heating module includes:

- hot air generator with condensation and integrated modulating adjustment, powered with methane gas
- kit for transformation of power with liquefied petroleum gas (LPG)
- kit of steel chimney for exhaust fumes
- All the control and safety devices

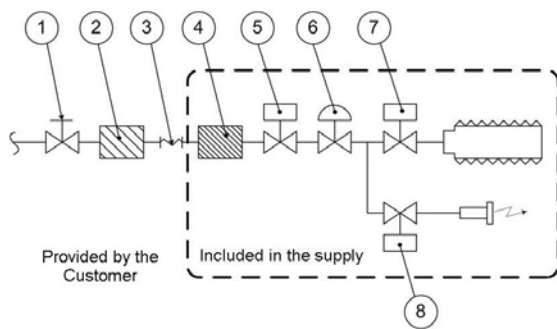

1. GAS COCK
2. GAS FILTER (LARGE SECTION)
3. ANTI-VIBRATION JOINT
4. GAS FILTER (SMALL SECTION)
5. SAFET GAS SOLENOID VLAVE
6. PRESSURE STABILISER
7. MAIN GAS BURNER SOLENOID VALVE
8. PILOT BURNER GAS SOLENOID VALVE

		35kW		44kW		65kW		82kW		100kW		130kW	
NOx class	Val	5											
		min	max	min	max	min	max	min	max	min	max	min	max
Rated thermal input	kW	7.6	34.85	8.50	42.00	12.40	65.00	16.40	82.00	21.00	100.00	12.40	130.00
Efficiency Hi (P.C.I.)	%	106.97	96.30	105.88	96.19	108.06	96.82	108.35	97.60	108.57	97.15	108.06	96.82
Efficiency Hs (P.C.S.)	%	96.37	86.76	95.39	86.66	97.36	87.22	97.62	87.93	97.81	87.52	97.36	87.22
Max condensation produced	l/h	0.9		1.1		2.1		3.3		2.7		4.2	
Carbon monoxide CO (0% di O ₂)	ppm	<5											
Nitrogen oxides - NOx (0% di O ₂)		41 mg / kWh 23 ppm		35 mg / kWh 20 ppm		40 mg / kWh 23 ppm		34 mg / kWh 19 ppm		45 mg / kWh 26 ppm		40 mg / kWh 23 ppm	
Available flue pressure	Pa	90		90		120		120		120		120	
Gas connection diameter	GAS	UNI ISO 7/1-3/4"		UNI ISO 7/1-3/4"		UNI ISO 7/1-3/4"		UNI ISO 7/1-1"		UNI ISO 7/1-1"		UNI ISO 7/1-1"	
Exhaust pipe diameter	mm	80		80		80		80		80		2 X 80	

A	<p>Applicare la guarnizione piana 15x5 adesiva lungo il perimetro delle flange del Modulo Gas in modo di garantire la completa assenza di bypass d'aria</p> <p><i>Apply the flat adhesive gasket 15x5 on the Gas Module flange perimeter to guarantee the absence of air bypass</i></p>
B	<p>Fissare con viti la staffa di sostegno del camino al pannello frontale del MG</p> <p><i>Fix with screws the flue supporting bracket to the GM frontal panel</i></p>
C	<p>Fissare tramite fascette le allunghe alla staffa di sostegno del camino</p> <p><i>Fix the extensions with clamps to the flue supporting bracket</i></p>
D	<p>Fissare i terminali di aspirazione in ambiente e i componenti dei camini (curve, allunghe, terminali) tramite le relative guarnizioni</p> <p><i>Fix the suction terminals in ambient and the fuel components (curves, extensions, terminals) by the corresponding gaskets</i></p>

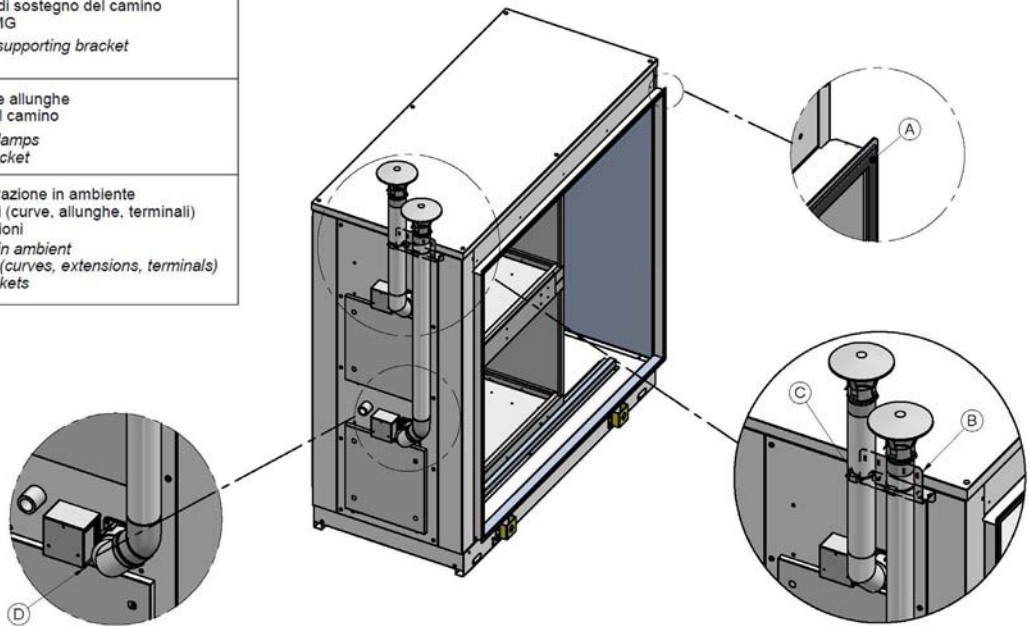

E	<p>Togliere le chiusure delle flange di mandata dell' unità. Avvicinare l'unità al Modulo Gas accoppiando le flange mandata tramite i morsetti in dotazione e serrando le viti in modo di garantire la completa assenza di bypass d'aria</p> <p><i>Remove the unit supply flange closing. Approach the unit to the Gas Module matching the supply flanges by means of the supplied terminals and screwing up to guarantee the absence of air bypass</i></p>
---	-------------------------------------------------------------------------------------------------------------------------------------------------------------------------------------------------------------------------------------------------------------------------------------------------------------------------------------------------------------------------------------------------------------------------------------------------------------

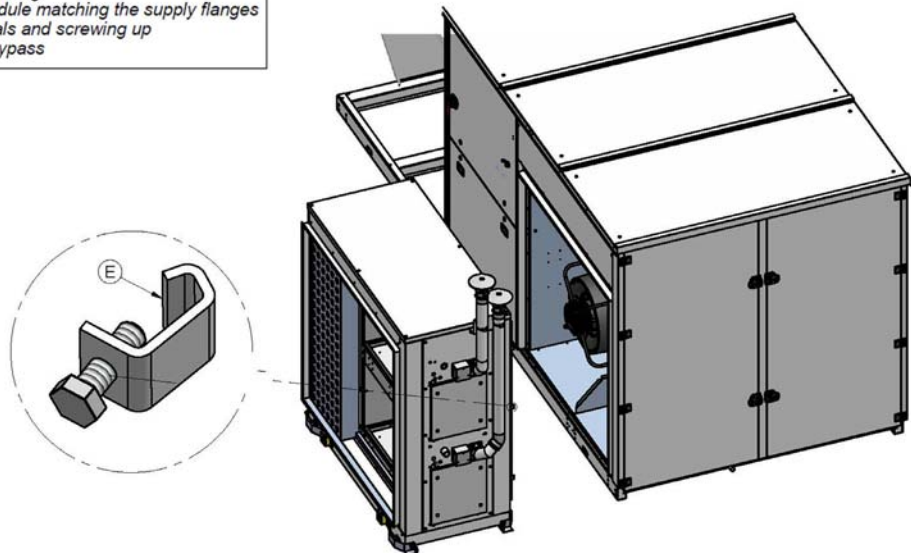

10.6 Gas heating module with 2-stage control

System maintenance booklet

- It must be kept in the place of installation of the unit
- It must be filled-in upon commissioning
- It must be updated with the results of the periodical checks, of the routine and extraordinary maintenance interventions.

Gas connection

- Read the gas heating module manual.
- Connection must be carried out by qualified personnel.
- use certified components and comply with the local standards in force
- install on the gas connection: cock, large section filter and anti-vibration joint
- check the supply pressure is correct and stable, in particular where more uses are inserted on the same line.

The heating module includes:

- hot air generator with condensation and integrated modulating adjustment, power with methane gas
- kit for transformation of power with liquefied petroleum gas (LPG)
- kit of steel chimney for exhaust fumes
- All the control and safety devices

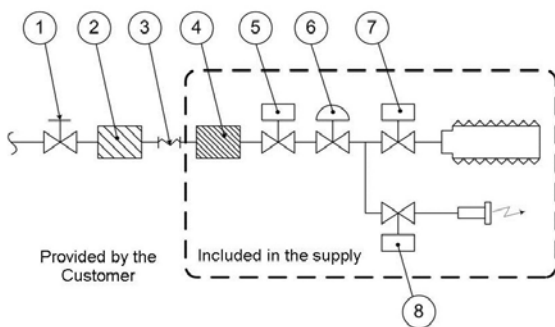

1. GAS COCK
2. GAS FILTER (LARGE SECTION)
3. ANTI-VIBRATION JOINT
4. GAS FILTER (SMALL SECTION)
5. SAFETY GAS SOLENOID VALVE
6. PRESSURE STABILISER
7. MAIN GAS BURNER SOLENOID VALVE
8. PILOT BURNER GAS SOLENOID VALVE

		35kW		44kW		53kW		74kW		100kW		147kW	
NOx class	Val	5											
		min	max	min	max	min	max	min	max	min	max	min	max
Rated thermal input	kW	27,5	34,8	35,5	44,0	42,4	52,2	60,0	73,5	81,8	100,0	60,0	147,0
Efficiency Hi (P.C.I.)	%	93,7	91,8	93,2	91,3	93,4	91,8	93,7	91,8	93,9	92,3	93,7	91,8
Efficiency Hs (P.C.S.)	%	84,3	82,6	83,8	82,2	84,1	82,6	84,3	82,6	84,5	83,1	84,3	82,6
Available flue pressure	Pa	120		120		130		140		140		140	
Gas connection diameter	GAS	UNI ISO 7/1-3/4"		UNI ISO 7/1-3/4"		UNI ISO 7/1-3/4"		UNI ISO 7/1-3/4"		UNI ISO 7/1-1"		UNI ISO 7/1-1"	
Exhaust pipe diameter	mm	80		80		80		80		80		2 X 80	

10.7 Heater humidifier

Start-up

Check the water supply pressure is not higher than 3 bar.

Open the flow rate measuring device/regulator and adjust it on 50% of the value in the table.

Wait 10/15 minutes so the heater soaks and starts.

Adjust the water flow rate by choosing whether to give greater importance to comfort or containment of the water consumption.

With an EXCESSIVE flow rate, it is possible for the water to flow in the channels or overflow from the bowl.

With INSUFFICIENT flow rate there is no humidifier action.

The heater is correctly wet if a veil of water shows on the external surface (with fan still).

Maintenance

The duration in time and absence of faults require constant cleaning which periodicity depends on different factors: concentration of dust in the air, water hardness, type of operation, etc..

When cleaning comply with the following prescriptions:

1. Close the water shut-off shutter
2. Remove the evaporating heater
3. Remove the casing panel corresponding to the humidifier
4. Remove the water distributor
5. Remove the evaporating heater
6. Was evaporating heater: the evaporating heater can be washed with water against lime deposits, but must be replaced if the deposits are of limescale type
7. Clean the spraying pipe, found on the alveolar distributor, with metal brush and steel points for the small holes
8. Check the water connection pipe is in good conditions, without holes or cuts that may cause water to leak
9. Wash inside the tank and the various components
10. Remount the evaporating heaters. ATTENTION: The evaporating heaters have a pre-set position to respect the air and water direction, that must be in counter-current. The incorrect position jeopardises the good operation and can cause flowing of the water downstream
11. Upon dehumidifier re-start, check operation again

11 Decommissioning

11.1 Disconnecting

Only authorised personnel must disconnect the unit.

Avoid leak or spills into the environment.

Before disconnecting the unit, the following must be recovered, if present:

- refrigerant gas
- anti-freeze solutions in the water circuit

Awaiting dismantling and disposal, the unit can also be stored outdoors, if the electrical, cooling and water circuits of the unit have 100% integrity and are isolated, bad weather and rapid change in temperature will not result in any environmental impact.

11.2 Dismantling and disposal

The unit must always be sent to authorised centres for dismantling and disposal.

When dismantling the unit, the fan, the motor and the coil, if operating, may be recovered by the specialist centres for reuse.

All the materials must be recovered or disposed of in compliance with the corresponding national standards in force.

For further information on the decommissioning of the unit, contact the manufacturer.

11.3 Directive EC RAEE

The units covered by the legislation in question are marked with the symbol on the side.

With the aim of protecting the environment, all of our units are produced in compliance with Directive EC on waste electrical and electronic equipment (RAEE).

The potential effects on the environment and on human health due to the presence of hazardous substances are shown in the use and maintenance manual in the section on residual risks.

Information in addition to that indicated below, if required, can be obtained from the manufacturer/distributor/importer, who are responsible for the collection/handling of waste originating from equipment covered by EC-RAEE. This information is also available from the retailer who sold this appliance or from the local authorities who handle waste.

Directive EC-RAEE requires disposal and recycling of electrical and electronic equipment as described therein to be handled through appropriate collection, in suitable centres, separate from collection for the disposal of mixed urban waste.

The user must not dispose of the unit at the end of its life cycle as urban waste, it must instead be handed over to appropriate collection centres as set forth by current standards or as instructed by the distributor.

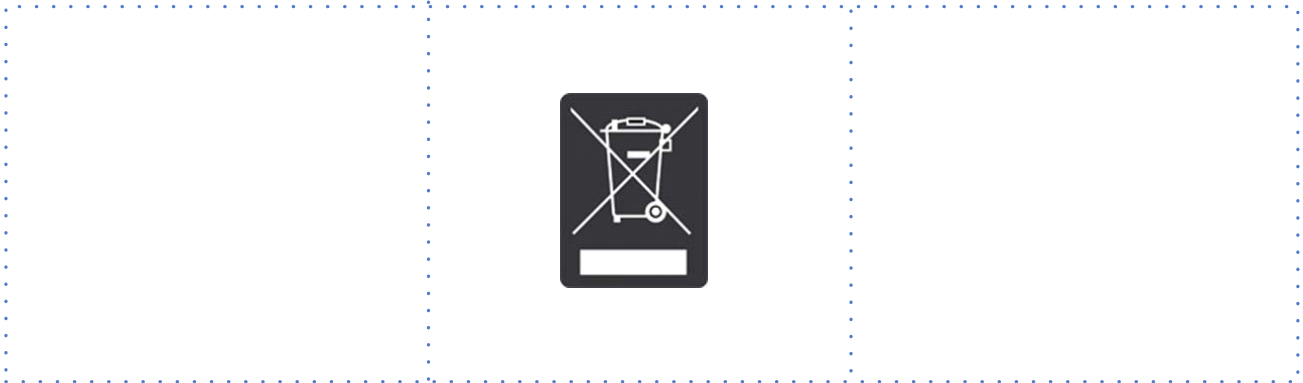

12 Residual risks

General description

In this section the most common situations are indicated, as these cannot be controlled by the manufacturer and could be a source of risk situations for people or things.

Danger zone

This is an area in which only an authorised operator may work.

The danger zone is the area inside the unit which is accessible only with the deliberate removal of protections or parts thereof.

Handling

The handling operations, if implemented without all of the protection necessary and without due caution, may cause the drop or the tipping of the unit with the consequent damage, even serious, to persons, things or the unit itself.

Handle the unit following the instructions provided in the present manual regarding the packaging and in compliance with the local regulations in force. Should the refrigerant leak please refer to the refrigerant "Safety sheet".

Installation

The incorrect installation of the unit could cause water leaks, condensate accumulation, leaking of the refrigerant, electric shock, poor operation or damage to the unit itself.

Check that the installation has been implemented by qualified technical personnel only and that the instructions contained in the present manual and the local regulations in force have been adhered to.

The installation of the unit in a place where even infrequent leaks of inflammable gas and the accumulation of this gas in the area surrounding the area occur could cause explosions or fires.

Carefully check the positioning of the unit.

The installation of the unit in a place unsuited to support its weight and/or guarantee adequate anchorage may result in consequent damage to things, people or the unit itself.

Carefully check the positioning and the anchoring of the unit.

Easy access to the unit by children, unauthorised persons or animals may be the source of accidents, some serious.

Install the unit in areas which are only accessible to authorised person and/or provide protection against intrusion into the danger zone.

General risks

Smell of burning, smoke or other signals of serious anomalies may indicate a situation which could cause damage to people, things or the unit itself.

Electrically isolate the unit (yellow-red isolator).

Contact the authorised service centre to identify and resolve the problem at the source of the anomaly.

Accidental contact with exchange batteries, compressors, air delivery tubes or other components may cause injuries and/or burns.

Always wear suitable clothing including protective gloves to work inside the danger zone.

Maintenance and repair operations carried out by non-qualified personnel may cause damage to persons, things or the unit itself.

Always contact the qualified assistance centre.

Failing to close the unit panels or failure to check the correct tightening of all of the panelling fixing screws may cause damage to persons, things or the unit itself.

Periodically check that all of the panels are correctly closed and fixed.

If there is a fire the temperature of the refrigerant could reach values that increase the pressure to beyond the safety valve with the consequent possible projection of the refrigerant itself or explosion of the circuit parts that remain isolated by the closure of the tap.

Do not remain in the vicinity of the safety valve and never leave the refrigerant system taps closed.

Electric parts

An incomplete attachment line to the electric network or with incorrectly sized cables and/or unsuitable protective devices can cause electric shocks, intoxication, damage to the unit or fires.

Carry out all of the work on the electric system referring to the electric layout and the present manual ensuring the use of a system thereto dedicated.

An incorrect fixing of the electric components cover may lead to the entry of dust, water etc inside and may consequently electric shocks, damage to the unit or fires.

Always fix the unit cover properly.

When the metallic mass of the unit is under voltage and is not correctly connected to the earthing system it may be as source of electric shock and electrocution.

Always pay particular attention to the implementation of the earthing system connections.

Contact with parts under voltage accessible inside the unit after the removal of the guards can cause electric shocks, burns and electrocution.

Open and padlock the general isolator prior to removing the guards and signal work in progress with the appropriate sign.

Contact with parts that could be under voltage due to the start up of the unit may cause electric shocks, burns and electrocution.

When voltage is necessary for the circuit open the isolator on the attachment line of the unit itself, padlock it and display the appropriate warning sign.

Moving parts

Contact with the transmissions or with the fan aspiration can cause injuries. Prior to entering the inside of the unit open the isolator situated on the connection line of the unit itself, padlock and display the appropriate warning sign.

Contact with the fans can cause injury.

Prior to removing the protective grill or the fans, open the isolator on the attachment line of the unit itself, padlock it and display the appropriate warning sign.

Refrigerant

The intervention of the safety valve and the consequent expulsion of the gas refrigerant may cause injuries and intoxication.

Always wear suitable clothing including protective gloves and eyeglasses for operations inside the danger zone.

Should the refrigerant leak please refer to the refrigerant "Safety sheet".

Contact between open flames or heat sources with the refrigerant or the heating of the gas circuit under pressure (e.g. during welding operations) may cause explosions or fires.

Do not place any heat source inside the danger zone.

The maintenance or repair interventions which include welding must be carried out with the system off.

Hydraulic parts

Defects in tubing, the attachments or the removal parts may cause a leak or water projection with the consequent damages to people, things or shortcircuit the unit.

STANDARD AIRFLOW

General technical data

Size				15.2	18.2	20.4	25.4	30.4	33.4	40.4	44.4
Cooling											
Cooling capacity	CAK	1	kW	48,9	59,0	74,0	84,6	91,9	105,2	122,3	130,4
Sensible capacity		1	kW	38,3	45,6	55,8	63,3	70,3	78,1	89,0	93,6
Compressor power input		1	kW	12,6	16,6	20,0	21,7	25,0	28,0	34,8	38,6
EER		1		3,88	3,55	3,70	3,90	3,68	3,76	3,51	3,38
Cooling capacity	CBK	2	kW	51,1	61,2	76,8	88,1	95,6	109,7	127,1	135,0
Sensible capacity		2	kW	39,1	46,8	57,5	64,4	70,5	80,1	90,4	95,6
Compressor power input		2	kW	12,8	16,7	20,3	22,0	25,3	28,3	35,3	39,1
EER		2		3,99	3,66	3,78	4,00	3,78	3,88	3,60	3,45
Cooling capacity	CCK	3	kW	51,9	62,5	77,8	89,3	96,9	111,4	129,5	137,5
Sensible capacity		3	kW	39,4	47,3	58,0	64,9	71,2	80,9	91,4	97,0
Compressor power input		3	kW	12,5	16,2	19,8	21,5	24,7	27,5	34,2	37,8
EER		3		4,15	3,86	3,93	4,15	3,92	4,05	3,79	3,64
Cooling capacity	CCKP	3	kW	55,4	66,4	83,3	95,5	103,7	119,0	137,8	147,6
Sensible capacity		3	kW	42,1	50,5	62,5	69,8	71,9	86,3	97,4	104,4
Compressor power input		3	kW	12,7	16,6	20,1	21,8	25,1	28,0	35,0	38,8
EER		3		4,36	4,00	4,14	4,38	4,13	4,25	3,94	3,80
Heating											
Heating capacity	CAK	1	kW	47,4	60,0	69,9	85,5	93,1	108,4	133,3	141,1
Compressor power input		1	kW	9,7	12,5	16,0	18,3	21,1	24,8	30,5	34,6
COP		1		4,89	4,80	4,37	4,67	4,41	4,37	4,37	4,08
Heating capacity	CBK	2	kW	47,8	60,6	71,0	86,4	94,3	110,0	135,4	143,6
Compressor power input		2	kW	8,9	11,4	14,5	16,7	19,4	22,7	28,0	31,9
COP		2		5,37	5,32	4,90	5,17	4,86	4,85	4,84	4,50
Heating capacity	CCK	3	kW	49,2	62,9	72,7	88,6	96,7	113,2	139,8	148,4
Compressor power input		3	kW	9,1	11,6	14,7	16,9	19,7	23,0	28,5	32,6
COP		3		5,41	5,42	4,95	5,24	4,91	4,92	4,91	4,55
Heating capacity	CCKP	3	kW	51,2	65,4	76,1	92,7	101,2	118,0	145,3	154,0
Compressor power input		3	kW	9,2	11,8	15,0	17,2	20,0	23,4	28,9	32,9
COP		3	kW	5,57	5,54	5,07	5,39	5,06	5,04	5,03	4,68
THOR recovery efficiency		4	%	83	81	84	83	81	85	82	81
Compressor											
Type of compressors		5		Scroll	Scroll	Scroll	Scroll	Scroll	Scroll	Scroll	Scroll
No. of compressors			Nr	2	2	4	4	4	4	4	4
Std Capacity control steps			Nr	2	3	4	4	4	4	4	4
Refrigeration circuits			Nr	1	1	2	2	2	2	2	2
Air Handling Section Fans (Supply)											
Type of supply fan		6		RAD	RAD	RAD	RAD	RAD	RAD	RAD	RAD
No. of supply fans			Nr	1	1	2	2	2	2	2	2
Fan diameter			mm	630	630	560	560	560	630	630	630
Supply airflow			m ³ /h	2500	3194	3750	4167	4722	5139	5833	6389
Supply airflow			l/s	9000	11500	13500	15000	17000	18500	21000	23000
Installed unit power			kW	2.75	2.75	2.90	2.90	2.90	2.75	2.75	2.75
Max. static pressure supply fan		7	Pa	510	390	510	510	510	510	440	380

Performances in cooling: Indoor air temp. 27°C/19°C W.B. Entering external exchanger air temperature 35°C D.B./24°C W.B. EER referred only to compressors
 Performance in Heating: Indoor air temp. 20°C D.B./12°C W.B. entering air to the external exchanger 7°C/6°C W.B.
 COP referred only to compressors

1. Performance refers to operation at full re-circulation
2. Performance with 30% of outdoor air
3. Performance with 30% of outdoor air including the energy recovery on the exhaust air

4. Energy recovery efficiency determined on the exhaust air. Indoor temperature 20°C D.B./12°C W.B., outdoor temperature 7°C D.B./6°C W.B.
5. SCROLL = scroll compressor
6. RAD = radial fan electronically controlled
7. Net outside static pressure to win the outlet and intake onboard pressure drops
8. Configuration with double fan section for recirculation, fresh air, exhaust, thermodynamic recovery (CCK) and configuration with double fan section with fresh air and THOR thermodynamic recovery (CCKP)
9. AX = axial fan

Size				15.2	18.2	20.4	25.4	30.4	33.4	40.4	44.4
High static pressure air handling section fans (OPTIONAL)											
Type of supply fan				RAD	RAD	RAD	RAD	RAD	RAD	RAD	RAD
Number of supply fans			Nr	1	1	2	2	2	2	2	2
Fan diameter			mm	500	500	500	500	500	500	500	500
Supply airflow			l/s	2500	3194	3750	4167	4722	5139	5833	6389
Supply airflow			m ³ /h	9000	11500	13500	15000	17000	18500	21000	23000
Installed unit power			kW	5.5	5.5	5.5	5.5	5.5	5.5	5.5	5.5
Max. static pressure supply fan			Pa	1020	825	1020	1020	1020	1020	1000	830
Fans (Exhaust) (only CCK, CCKP-THOR configuration)											
Type of fans		6		RAD	RAD	RAD	RAD	RAD	RAD	RAD	RAD
No. of fans		8		1	1	2	2	2	2	2	2
Installed unit power		8	kW	2,7	2,7	1,3	1,3	1,3	2,7	2,7	2,7
External Section Fans											
Type of fans		9		AX	AX	AX	AX	AX	AX	AX	AX
No. of fans			Nr	1	1	2	2	2	2	2	2
Fan diameter			mm	800	800	800	800	800	800	800	800
Standard airflow			l/s	5835	5835	11670	11670	11670	11670	11670	11670
Single power input			kW	1.50	1.50	1.50	1.50	1.50	1.50	1.50	1.50
Connections											
Condensate drain			mm	20	20	20	20	20	20	20	20
Power supply											
Standard power supply			V	400/3/50	400/3/50	400/3/50	400/3/50	400/3/50	400/3/50	400/3/50	400/3/50

Performances in cooling: Indoor air temp. 27°C/19°C W.B. Entering external exchanger air temperature 35°C D.B./24°C W.B. EER referred only to compressors
 Performance in Heating: Indoor air temp. 20°C D.B./12°C W.B. entering air to the external exchanger 7°C/6°C W.B. COP referred only to compressors

1. Performance refers to operation at full re-circulation

2. Performance with 30% of outdoor air

3. Performance with 30% of outdoor air including the energy recovery on the exhaust air

4. Energy recovery efficiency determined on the exhaust air. Indoor temperature 20°C D.B./12°C W.B., outdoor temperature 7°C D.B./6°C W.B.

5. SCROLL = scroll compressor

6. RAD = radial fan electronically controlled

7. Net outside static pressure to win the outlet and intake onboard pressure drops

8. Configuration with double fan section for recirculation, fresh air, exhaust, thermodynamic recovery (CCK) and configuration with double fan section with fresh air and THOR thermodynamic recovery (CCKP)

9. AX = axial fan

Sound levels

Size	Sound power level (dB)								Sound power level dB(A)	Sound pressure level dB(A)
	Octave band (Hz)									
	63	125	250	500	1000	2000	4000	8000		
15.2	85	86	84	79	78	72	69	63	83	64
18.2	86	83	85	81	80	75	70	64	84	66
20.4	90	88	89	82	80	78	71	66	86	67
25.4	91	89	89	83	81	78	73	69	87	68
30.4	90	89	89	85	83	80	74	69	88	69
33.4	92	89	90	86	84	82	74	71	89	70
40.4	93	90	91	86	84	82	75	72	90	71
44.4	94	91	92	88	85	82	77	73	91	72

The sound levels are referred to unit operating at full load in nominal conditions. The sound pressure level is referred at a distance of 1 m. from the ducted unit surface operating in free field conditions. External static pressure 50 Pa. (standard UNI EN ISO 9614-2)

Please note that when the unit is installed in conditions different from nominal test conditions (e.g. near walls or obstacles in general), the sound levels may undergo substantial variations.

Operating range (Cooling)

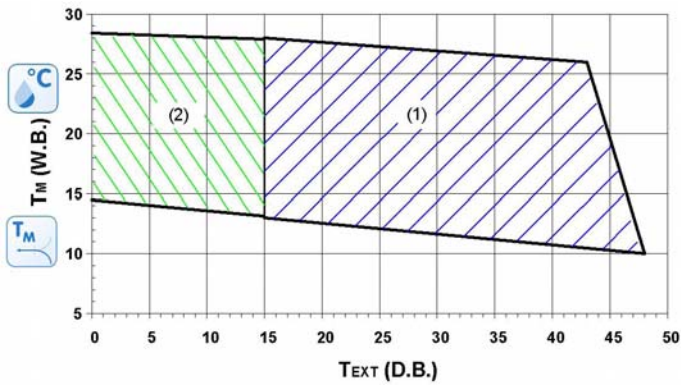

The limits are meant as an indication and they have been calculated by considering:

- general and non specific sizes,
- standard airflow,
- non-critical positioning of the unit and correct operating and maintenance of the unit,
- operating at full load

To verify the operation field of the operating units with percentages of outdoor air, always calculate the T_m mixing temperature at the internal heat exchanger input.

T_m = entering internal exchanger air temperature, temperature measured with wet bulb (W.B.=WET BULB)

T_{EXT} = entering internal exchanger air temperature, temperature measured with dry bulb (D.B.=DRY BULB)

1. Standard operating range
2. Operation range of the unit in FREE-COOLING mode

WET BULB TEMPERATURE - EXAMPLE

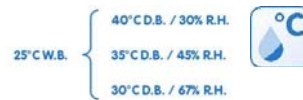

Operating range (Heating)

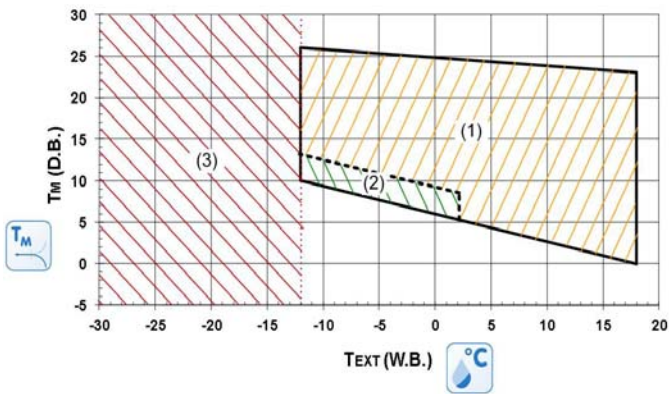

The limits are meant as an indication and they have been calculated by considering:

- general and non specific sizes,
- standard airflow,
- non-critical positioning of the unit and correct operating and maintenance of the unit,
- operating at full load

To verify the operation field of the operating units with percentages of outdoor air, always calculate the T_m mixing temperature at the internal heat exchanger input.

T_m = entering internal exchanger air temperature, temperature measured with dry bulb (D.B.=DRY BULB)

T_{EXT} = entering internal exchanger air temperature, temperature measured with wet bulb (W.B.=WET BULB)

1. Operation range at full load
2. Range in which the unit operation is allowed only for a limited period (max 1 hour)
3. Operation range of the unit equipped with "application for low outdoor temperature" and "hot water coil" or "gas heating module" options. The heat pump circuit is not active.

In extended operating mode, in heat pump operation with an outdoor air temperature of less than 6°C, the unit performs defrosts by reversing the cycle, activating one circuit at a time and maintaining the ventilation active to eliminate the ice that forms on the surfaces of the outside exchanger. In the event of negative temperatures, the water resulting from the defrosts must be drained so as to avoid the accumulation of ice near the base of the unit. Make sure that this does not constitute a danger for people or things. With an outdoor air temperature between -10°C and -30°C install the following options: hot water coil or gas heating module and outdoor air low temperature configuration.

Dimensional drawings

Size 15.2 - 18.2 - CAK and CBK configuration

DAA8F15-1_02
Date: 31/07/2014

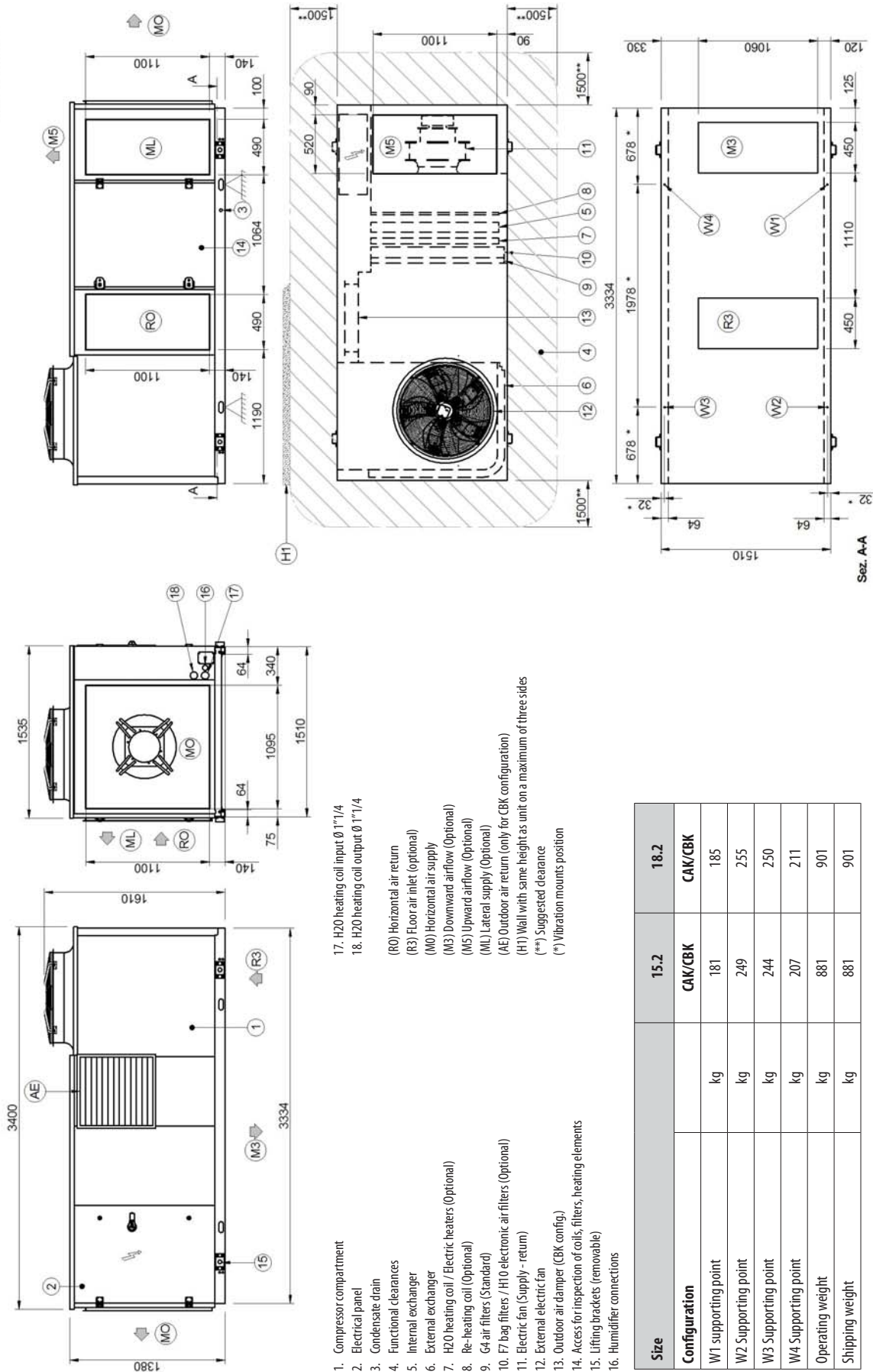

- 17. H2O heating coil input Ø 1"1/4
- 18. H2O heating coil output Ø 1"1/4
- (RO) Horizontal air return
- (R3) Floor air inlet (optional)
- (MO) Horizontal air supply
- (M3) Downward airflow (Optional)
- (MS) Upward airflow (Optional)
- (ML) Lateral supply (Optional)
- (AE) Outdoor air return (only for CBK configuration)
- (HT) Wall with same height as unit on a maximum of three sides
- (**) Suggested clearance
- (*) Vibration mounts position

- 1. Compressor compartment
- 2. Electrical panel
- 3. Condensate drain
- 4. Functional clearances
- 5. Internal exchanger
- 6. External exchanger
- 7. H2O heating coil / Electric heaters (Optional)
- 8. Re-heating coil (Optional)
- 9. G4 air filters (Standard)
- 10. F7 bag filters / H10 electronic air filters (Optional)
- 11. Electric fan (Supply - return)
- 12. External electric fan
- 13. Outdoor air damper (CBK config.)
- 14. Access for inspection of coils, filters, heating elements
- 15. Lifting brackets (removable)
- 16. Humidifier connections

Size	15.2	18.2
Configuration	CAK/CBK	CAK/CBK
W1 supporting point	181	185
W2 Supporting point	249	255
W3 Supporting point	244	250
W4 Supporting point	207	211
Operating weight	881	901
Shipping weight	881	901

The presence of optional accessories may result in a substantial variation of the weights shown in the table.

Size 15.2 - 18.2 Combustion module - CAK and CBK configuration

DAA8F15-1_GC01-GC09_00
Date: 04/12/2014

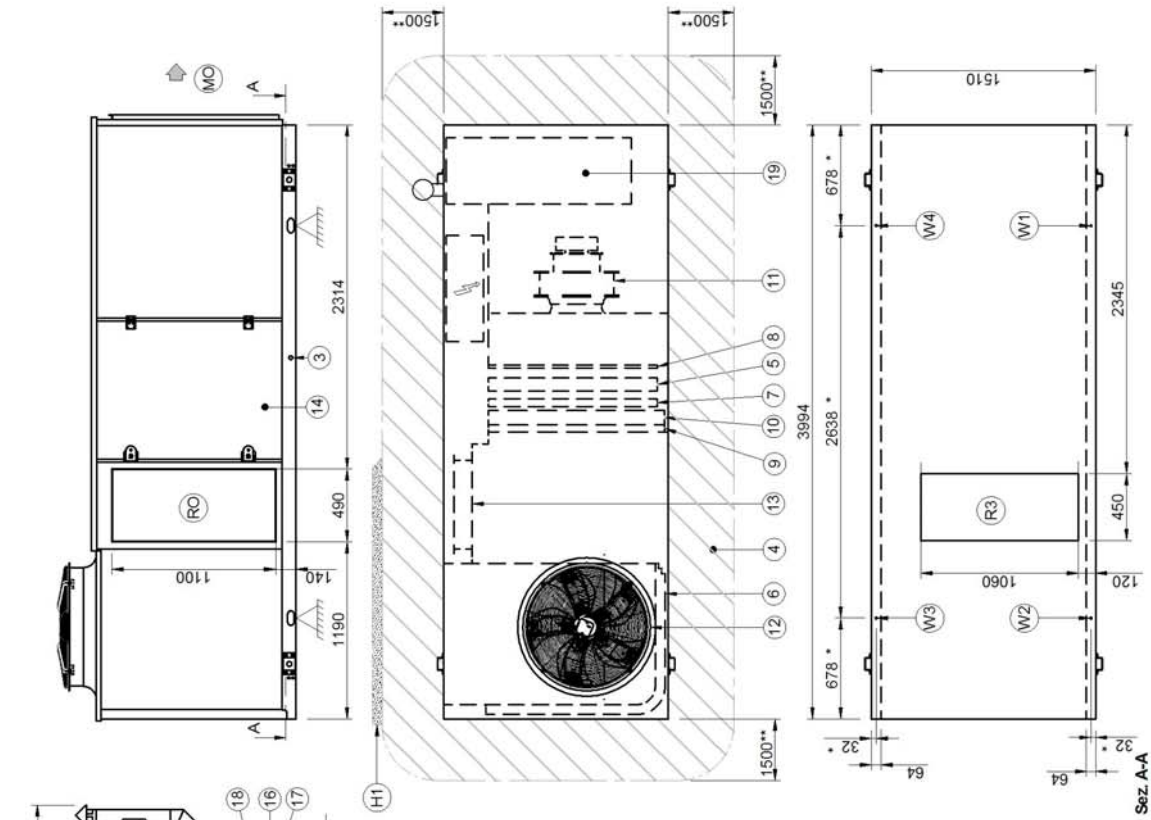

1. Compressor compartment
 2. Electrical panel
 3. Condensate drain
 4. Functional clearances
 5. Internal exchanger
 6. External exchanger
 7. H2O heating coil / Electric heaters (Optional)
 8. Re-heating coil (Optional)
 9. 64 air filters (Standard)
 10. F7 bag filters / H10 electronic air filters (Optional)
 11. Electric fan (Supply - return)
 12. External electric fan
 13. Outdoor air damper (CBK config.)
 14. Access for inspection of coils, filters, heating elements
 15. Lifting brackets (removable)
 16. Humidifier connections
 17. H2O heating coil input Ø 1"1/4
 18. H2O heating coil output Ø 1"1/4
 19. Gas module
- (RO) Horizontal air return
(R3) Floor air inlet (optional)
(MO) Horizontal air supply
(AE) Outdoor air return (only for CBK configuration)
(H1) Wall with same height as unit on a maximum of three sides
(**) Suggested clearance
(*) Vibration mounts position

Size	15.2	18.2
Configuration	CAK/CBK	CAK/CBK
W1 supporting point	kg	235
W2 Supporting point	kg	281
W3 Supporting point	kg	275
W4 Supporting point	kg	261
Operating weight	kg	1052
Shipping weight	kg	1052

The presence of optional accessories may result in a substantial variation of the weights shown in the table.

Size 15.2 - 18.2 - CCK and CCKP configuration

DAA8F15-1_CCK-CCKP_00
Date: 04/12/2014

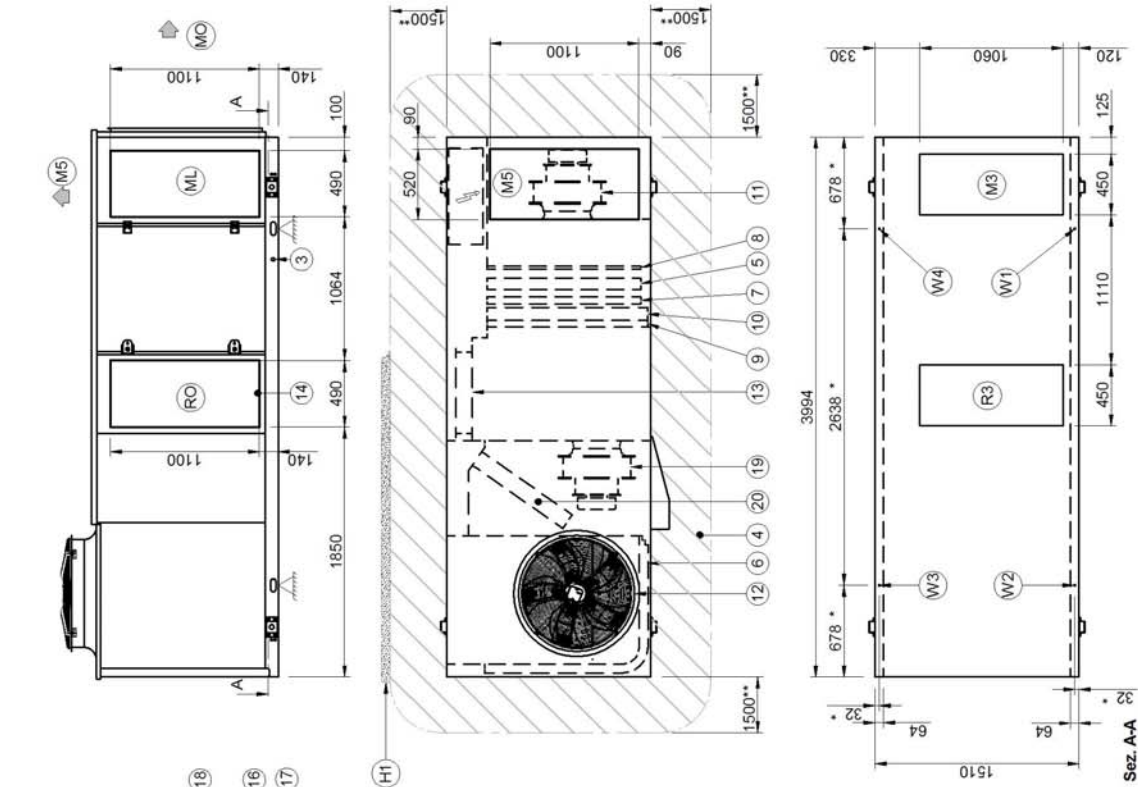

- 17. H2O heating coil input Ø 1"1/4
- 18. H2O heating coil output Ø 1"1/4
- 19. Exhaust electric fan
- 20. Exhaust air recovery coil (CCKP version)
- (RO) Horizontal air return
- (R3) Floor air inlet (Optional)
- (M0) Horizontal air supply
- (M3) Downward airflow (Optional)
- (M5) Upward airflow (Optional)
- (ML) Lateral supply (Optional)
- (AE) Outdoor air return
- (H1) Wall with same height as unit on a maximum of three sides
- (**) Suggested clearance
- (*) Vibration mounts position

- 1. Compressor compartment
- 2. Electrical panel
- 3. Condensate drain
- 4. Functional clearances
- 5. Internal exchanger
- 6. External exchanger
- 7. H2O heating coil / Electric heaters (Optional)
- 8. Re-heating coil (Optional)
- 9. G4 air filters (Standard)
- 10. F7 bag filters / H10 electronic air filters (Optional)
- 11. Electric fan (Supply - return)
- 12. External electric fan
- 13. Outdoor air damper
- 14. Access for inspection of coils, filters, heating elements
- 15. Lifting brackets (removable)
- 16. Humidifier connections

Size	15.2		18.2	
	CCK	CCKP	CCK	CCKP
W1 supporting point	209	277	213	282
W2 Supporting point	286	223	293	228
W3 Supporting point	281	258	287	264
W4 Supporting point	239	287	243	292
Operating weight	1015	1045	1036	1066
Shipping weight	1015	1045	1036	1066

The presence of optional accessories may result in a substantial variation of the weights shown in the table.

Size 15.2 - 18.2 Combustion module - CCK and CCKP configuration

DAA8F15-1_CCK-CCKP_GC01-GC09_00
Date: 04/12/2014

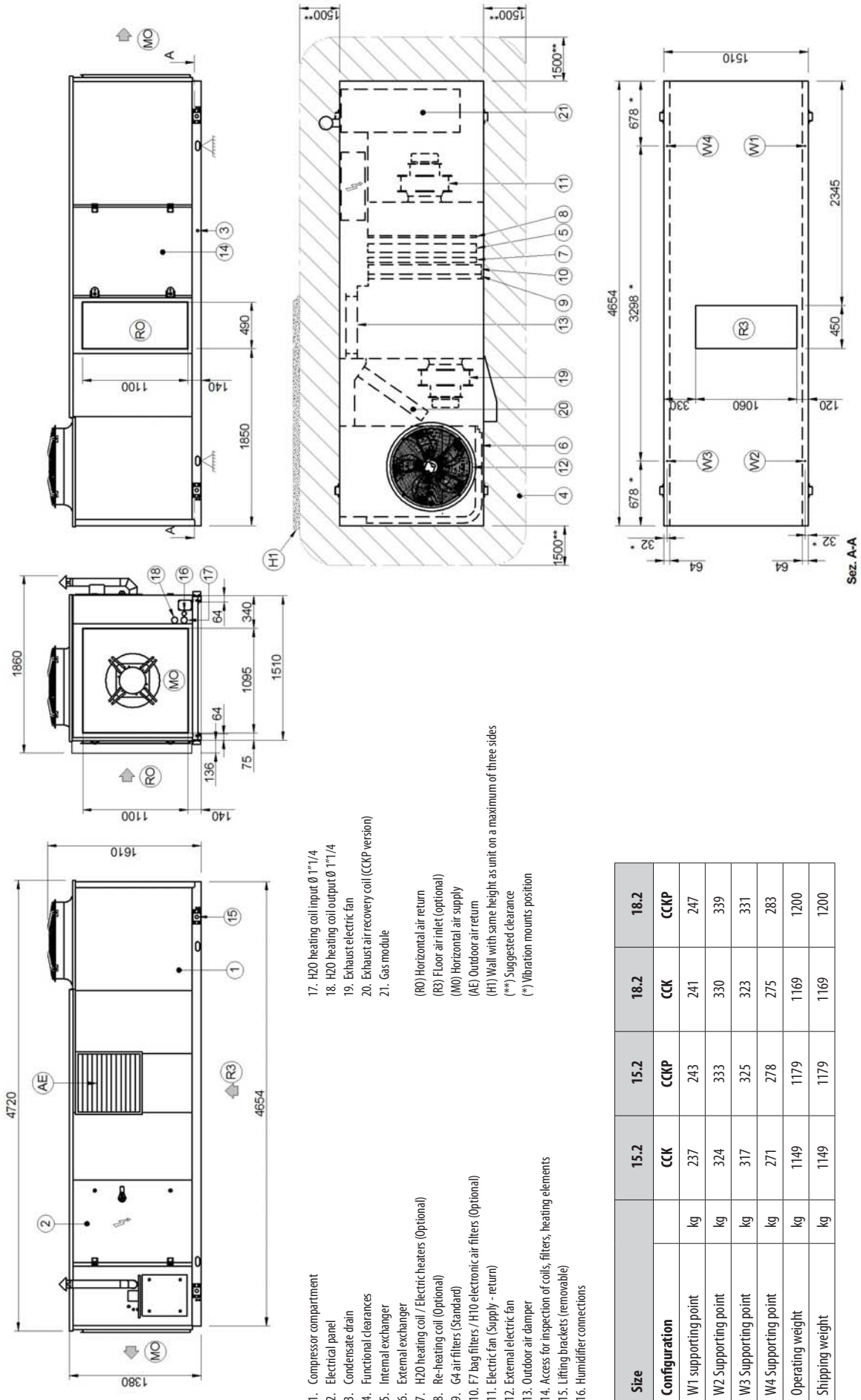

- 1. Compressor compartment
 - 2. Electrical panel
 - 3. Condensate drain
 - 4. Functional clearances
 - 5. Internal exchanger
 - 6. External exchanger
 - 7. H2O heating coil / Electric heaters (Optional)
 - 8. Re-heating coil (Optional)
 - 9. G4 air filters (Standard)
 - 10. F7 bag filters / H10 electronic air filters (Optional)
 - 11. Electric fan (Supply - return)
 - 12. External electric fan
 - 13. Outdoor air damper
 - 14. Access for inspection of coils, filters, heating elements
 - 15. Lifting brackets (removable)
 - 16. Humidifier connections
 - 17. H2O heating coil input $\varnothing 1\frac{1}{4}$
 - 18. H2O heating coil output $\varnothing 1\frac{1}{4}$
 - 19. Exhaust electric fan
 - 20. Exhaust air recovery coil (CCKP version)
 - 21. Gas module
- (RO) Horizontal air return
(R3) Floor air inlet (optional)
(M0) Horizontal air supply
(AE) Outdoor air return
(H1) Wall with same height as unit on a maximum of three sides
(**) Suggested clearance
(*) Vibration mounts position

Size	15.2	15.2	18.2	18.2
Configuration	CCK	CCKP	CCK	CCKP
W1 supporting point	kg 237	kg 243	kg 241	kg 247
W2 Supporting point	kg 324	kg 333	kg 330	kg 339
W3 Supporting point	kg 317	kg 325	kg 323	kg 331
W4 Supporting point	kg 271	kg 278	kg 275	kg 283
Operating weight	kg 1149	kg 1179	kg 1169	kg 1200
Shipping weight	kg 1149	kg 1179	kg 1169	kg 1200

The presence of optional accessories may result in a substantial variation of the weights shown in the table.

Size 20.4-25.4-30.4 - CAK and CBK configuration

DAA8F24-2_02
Date: 31/07/2014

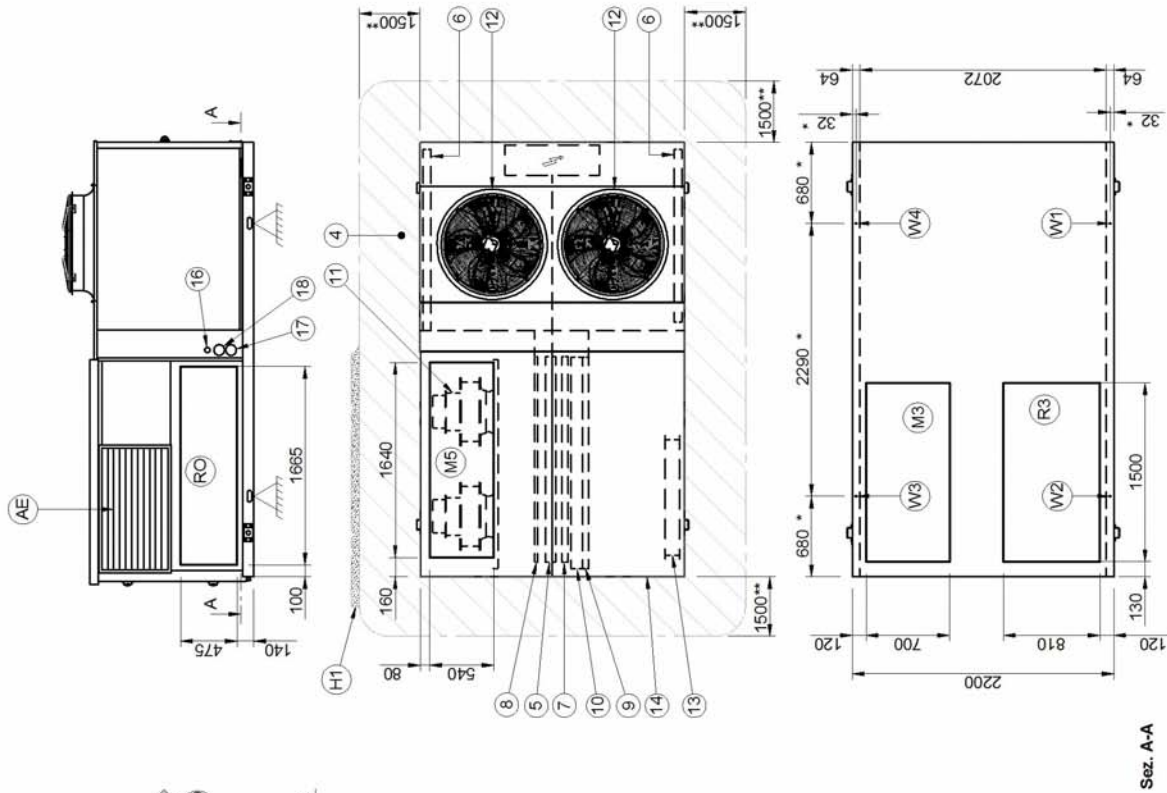

Sez. A-A

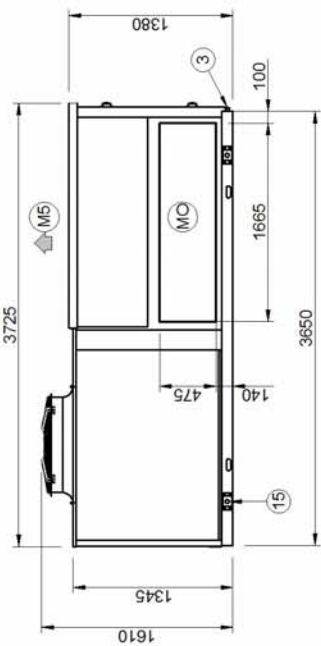

- 17. H2O heating coil input Ø 1"1/4
- 18. H2O heating coil output Ø 1"1/4
- (RO) Horizontal air return
- (R3) Floor air inlet (optional)
- (M0) Horizontal air supply
- (M3) Downward airflow (Optional)
- (M5) Upward airflow (Optional)
- (AE) Outdoor air return (only for CBK configuration)
- (H1) Wall with same height as unit on a maximum of three sides
- (**) Suggested clearance
- (*) Vibration mounts position

- 1. Compressor compartment
- 2. Electrical panel
- 3. Condensate drain
- 4. Functional clearances
- 5. Internal exchanger
- 6. External exchanger
- 7. H2O heating coil / Electric heaters (Optional)
- 8. Re-heating coil (Optional)
- 9. G4 air filters (Standard)
- 10. F7 bag filters / H10 electronic air filters (Optional)
- 11. Electric fan (Supply - return)
- 12. External electric fan
- 13. Outdoor air damper (CBK config.)
- 14. Access for inspection of coils, filters, heating elements
- 15. Lifting brackets (removable)
- 16. Humidifier connections

Size	20.4	25.4	30.4
Configuration	CAK/CBK	CAK/CBK	CAK/CBK
W1 supporting point	kg 391	kg 400	kg 403
W2 Supporting point	kg 294	kg 302	kg 304
W3 Supporting point	kg 336	kg 345	kg 347
W4 Supporting point	kg 405	kg 414	kg 417
Operating weight	kg 1426	kg 1461	kg 1471
Shipping weight	kg 1426	kg 1461	kg 1471

The presence of optional accessories may result in a substantial variation of the weights shown in the table.

Size 20.4-25.4-30.4 Combustion module - CAK and CBK configuration

DAA8F24-2_GC01X-GC11X_00
Date: 04/12/2014

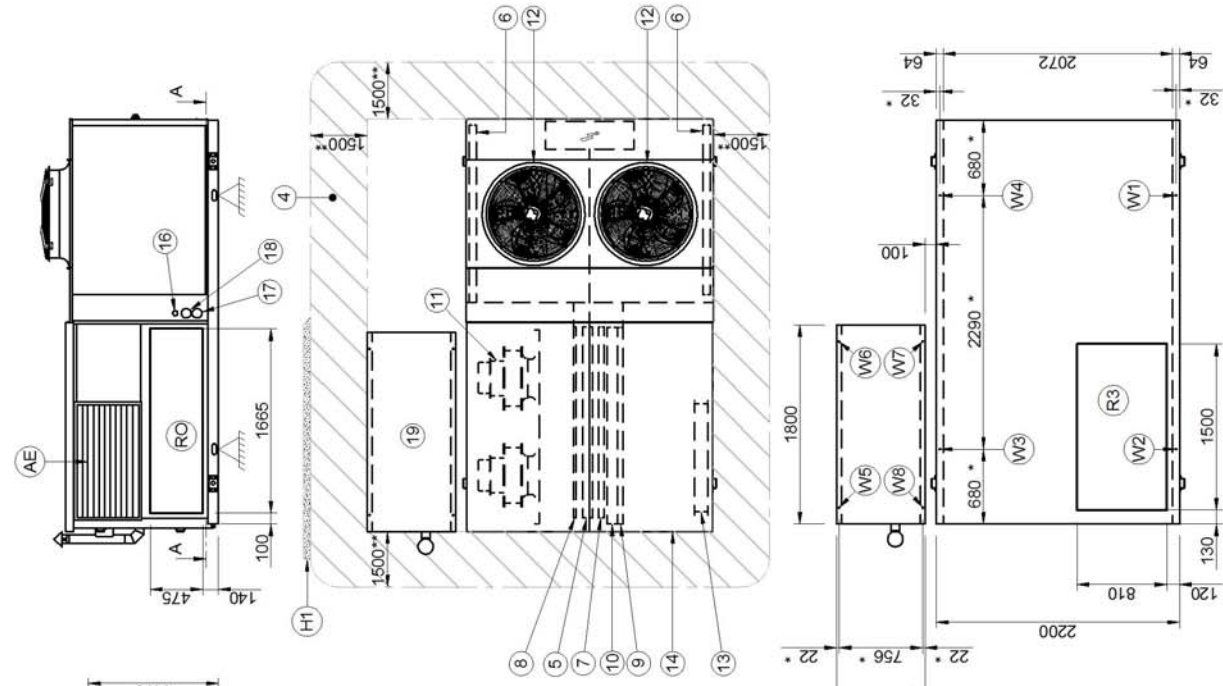

- 1. Compressor compartment
 - 2. Electrical panel
 - 3. Condensate drain
 - 4. Functional clearances
 - 5. Internal exchanger
 - 6. External exchanger
 - 7. H2O heating coil / Electric heaters (Optional)
 - 8. Re-heating coil (Optional)
 - 9. G4 air filters (Standard)
 - 10. F7 bag filters / H10 electronic air filters (Optional)
 - 11. Electric fan (Supply - return)
 - 12. External electric fan
 - 13. Outdoor air damper (CBK config.)
 - 14. Access for inspection of coils, filters, heating elements
 - 15. Lifting brackets (removable)
 - 16. Humidifier connections
 - 17. H2O heating coil input Ø 1"1/4
 - 18. H2O heating coil output Ø 1"1/4
 - 19. Gas module
- (RO) Horizontal air return
 (R3) Floor air inlet (optional)
 (M0) Horizontal air supply
 (AE) Outdoor air return (only for CBK configuration)
 (H1) Wall with same height as unit on a maximum of three sides
 (***) Suggested clearance
 (*) Vibration mounts position

Size	20.4	25.4	30.4
Configuration	CAK/CBK	CAK/CBK	CAK/CBK
W1 supporting point	kg 391	kg 400	kg 403
W2 Supporting point	kg 294	kg 302	kg 304
W3 Supporting point	kg 336	kg 345	kg 347
W4 Supporting point	kg 405	kg 414	kg 417
Operating weight	kg 1426	kg 1461	kg 1471
Shipping weight	kg 1426	kg 1461	kg 1471

GAS MODULE WEIGHT DISTRIBUTION

Size	24.4	25.4	30.4
W5 Supporting point	kg 75	kg 75	kg 75
W6 Supporting point	kg 63	kg 63	kg 63
W7 Supporting point	kg 63	kg 63	kg 63
W8 Supporting point	kg 75	kg 75	kg 75
Operating weight	kg 1702	kg 1737	kg 1747
Shipping weight	kg 1426	kg 1461	kg 1471

The presence of optional accessories may result in a substantial variation of the weights shown in the table.

Size 20.4-25.4-30.4 - CCK and CCKP configuration

DAA8F24-2_CCK-CCKP_00
Date: 05/12/2014

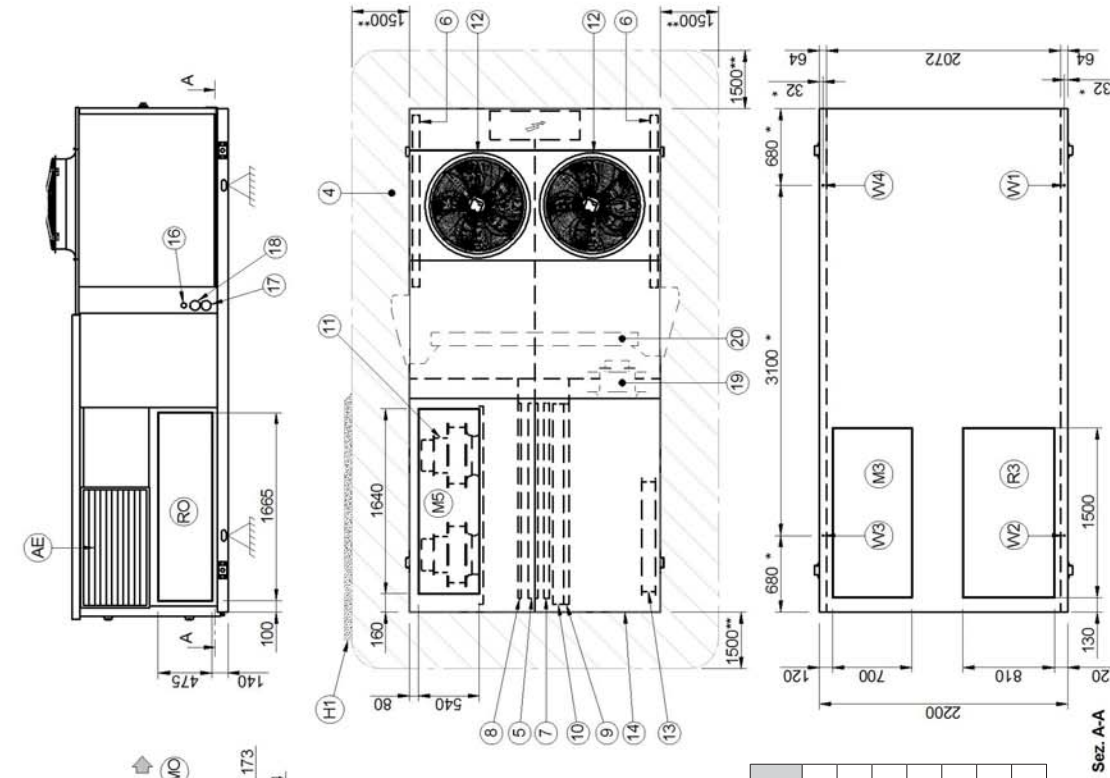

- 1. Compressor compartment
- 2. Electrical panel
- 3. Condensate drain
- 4. Functional clearances
- 5. Internal exchanger
- 6. External exchanger
- 7. H2O heating coil / Electric heaters (Optional)
- 8. Re-heating coil (Optional)
- 9. G4 air filters (Standard)
- 10. F7 bag filters / H10 electronic air filters (Optional)
- 11. Electric fan (Supply - return)
- 12. External electric fan
- 13. Outdoor air damper
- 14. Access for inspection of coils, filters, heating elements
- 15. Lifting brackets (removable)
- 16. Humidifier connections
- 17. H2O heating coil input Ø 1"1/4
- 18. H2O heating coil output Ø 1"1/4
- 19. Exhaust electric fan
- 20. Exhaust air recovery coil (CCKP version)
- (R0) Horizontal air return
- (R3) Floor air inlet (optional)
- (M0) Horizontal air supply
- (M3) Downward airflow (Optional)
- (M5) Upward airflow (Optional)
- (AE) Outdoor air return
- (H1) Wall with same height as unit on a maximum of three sides
- (**) Suggested clearance
- (*) Vibration mounts position

Size	20.4		25.4		30.4	
	CCK	CCKP	CCK	CCKP	CCK	CCKP
W1 supporting point	447	460	456	468	459	472
W2 Supporting point	338	348	346	356	348	358
W3 Supporting point	386	397	395	406	397	408
W4 Supporting point	463	476	472	485	475	488
Operating weight	1634	1681	1669	1715	1679	1726
Shipping weight	1634	1681	1669	1715	1679	1726

The presence of optional accessories may result in a substantial variation of the weights shown in the table.

Size 20.4-25.4-30.4 Combustion module - CCK and CCKP configuration

DAA8F24-2_CCK-CCKP_GC01X-GC11X_00
Date: 09/12/2014

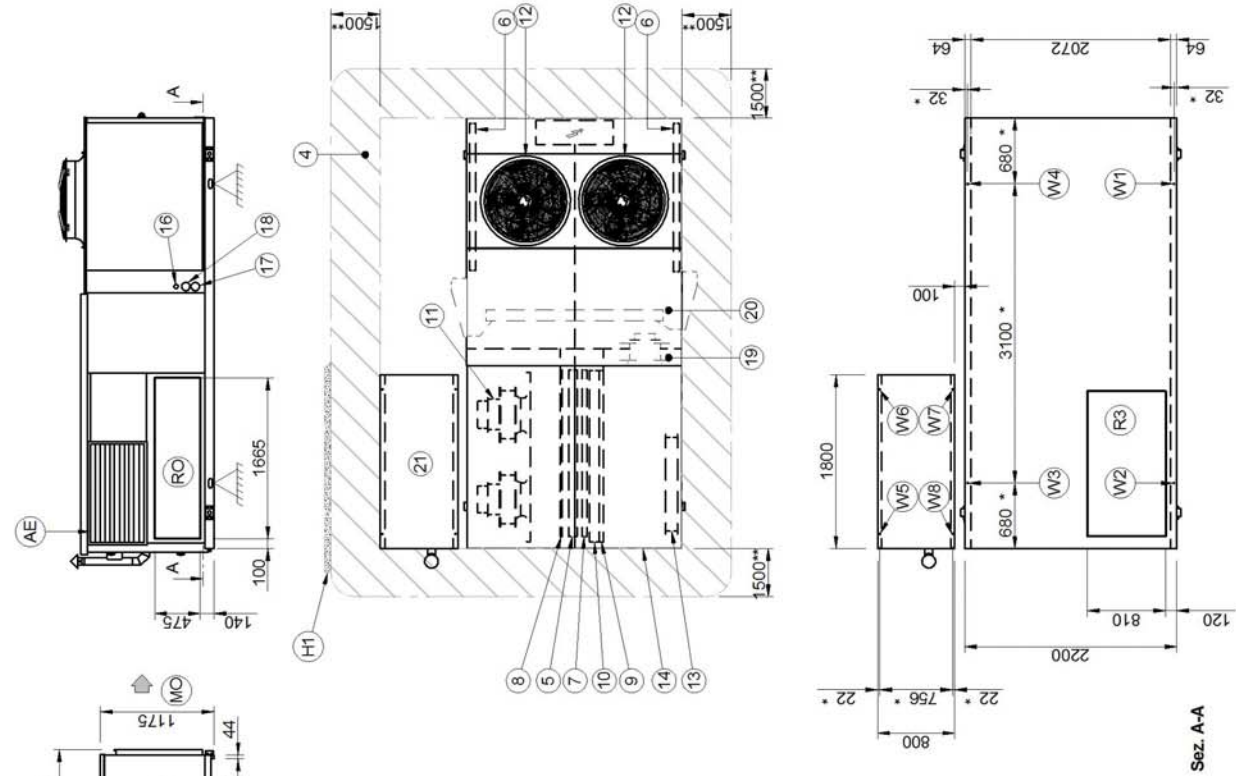

- 1. Compressor compartment
 - 2. Electrical panel
 - 3. Condensate drain
 - 4. Functional clearances
 - 5. Internal exchanger
 - 6. External exchanger
 - 7. H2O heating coil / Electric heaters (Optional)
 - 8. Re-heating coil (Optional)
 - 9. G4 air filters (Standard)
 - 10. F7 bag filters / H10 electronic air filters (Optional)
 - 11. Electric fan (Supply - return)
 - 12. External electric fan
 - 13. Outdoor air damper
 - 14. Access for inspection of coils, filters, heating elements
 - 15. Lifting brackets (removable)
 - 16. Humidifier connections
 - 17. H2O heating coil input Ø 1"1/4
 - 18. H2O heating coil output Ø 1"1/4
 - 19. Exhaust electric fan
 - 20. Exhaust air recovery coil (CCKP version)
 - 21. Gas module
- (RO) Horizontal air return
(R3) Floor air inlet (optional)
(MO) Horizontal air supply
(AE) Outdoor air return
(H1) Wall with same height as unit on a maximum of three sides
(**) Suggested clearance
(*) Vibration mounts position

Size	20.4	25.4	30.4	30.4
Configuration	CCK	CCK	CCK	CCKP
W1 supporting point	447	460	456	468
W2 Supporting point	338	348	346	356
W3 Supporting point	386	397	395	406
W4 Supporting point	463	476	472	485
Operating weight	1634	1681	1669	1715
Shipping weight	1634	1681	1669	1715

GAS MODULE WEIGHT DISTRIBUTION

Size	20.4	25.4	30.4
W5 Supporting point	75	75	75
W6 Supporting point	63	63	63
W7 Supporting point	63	63	63
W8 Supporting point	75	75	75
Operating weight	1910	1945	1955
Shipping weight	1634	1669	1679

The presence of optional accessories may result in a substantial variation of the weights shown in the table.

Grandezze 33.4-40.4-44.4 - Configurazione CAK e CBK

DAA8F35-2_02
Date: 31/07/2014

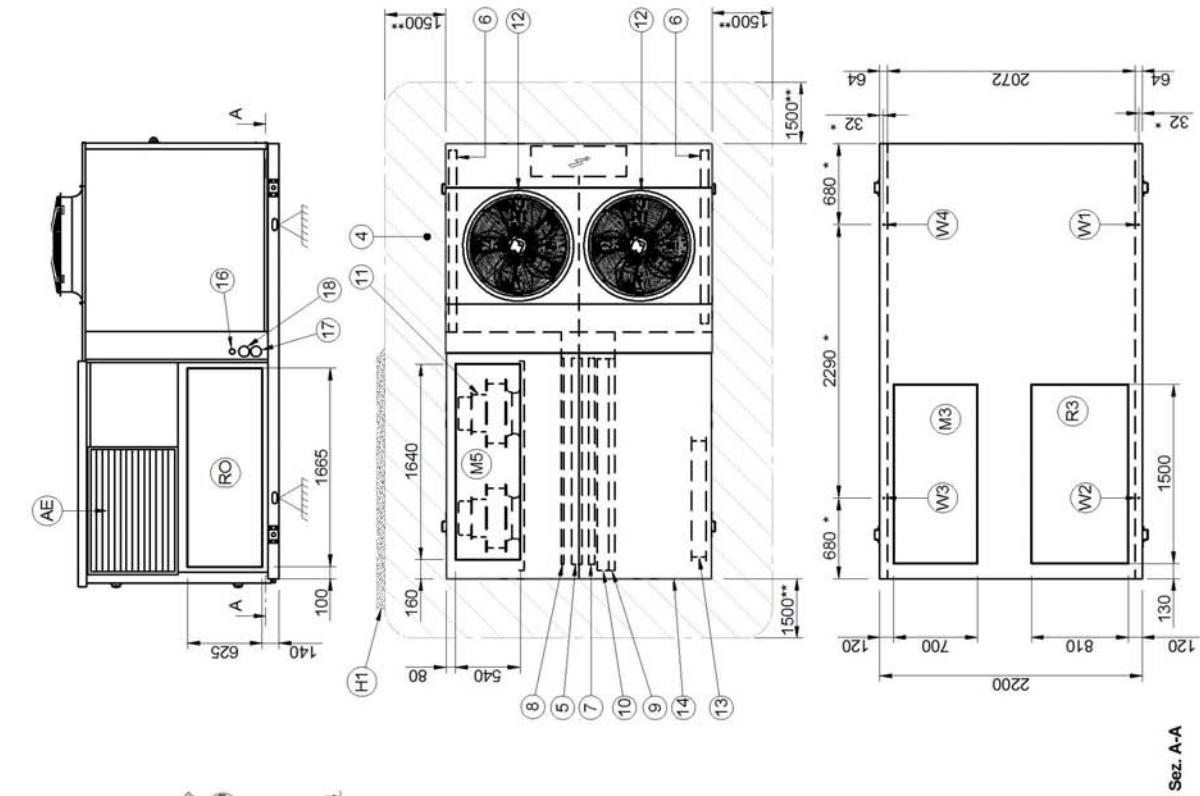

- 17. H2O heating coil input Ø 1"1/4 / Recovery from the food refrigeration Ø 2"
- 18. H2O heating coil output Ø 1"1/4 / Recovery from the food refrigeration Ø 2"
- (RO) Horizontal air return
- (R3) Floor air inlet (optional)
- (M0) Horizontal air supply
- (M3) Downward airflow (Optional)
- (M5) Upward airflow (Optional)
- (AE) Outdoor air return (only for CBK configuration)
- (HI) Wall with same height as unit on a maximum of three sides
- (**) Suggested clearance
- (*) Vibration mounts position

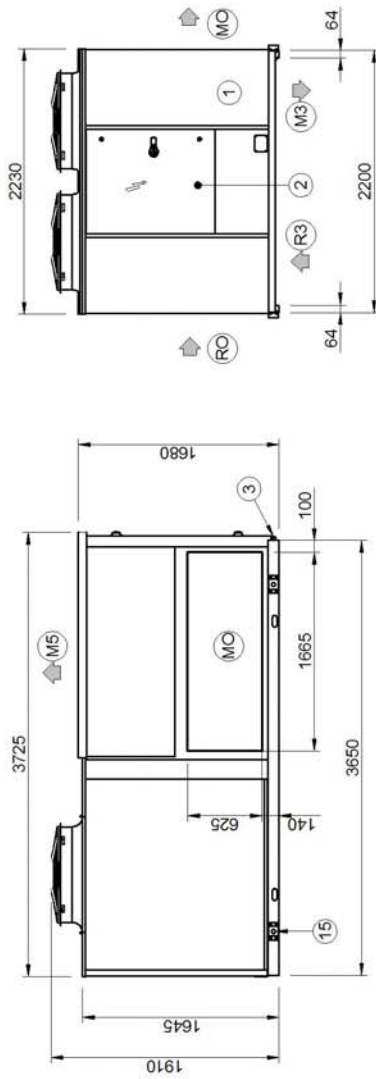

- 1. Compressor compartment
- 2. Electrical panel
- 3. Condensate drain
- 4. Functional clearances
- 5. Internal exchanger
- 6. External exchanger
- 7. H2O heating coil / Electric heaters (Optional)
- 8. Re-heating coil (Optional)
- 9. G4 air filters (Standard)
- 10. F7 bag filters / H10 electronic air filters (Optional)
- 11. Electric fan (Supply - return)
- 12. External electric fan
- 13. Outdoor air damper (CBK config.)
- 14. Access for inspection of coils, filters, heating elements
- 15. Lifting brackets (removable)
- 16. Humidifier connections

Size	33.4	40.4	44.4
Configuration	CAK/CBK	CAK/CBK	CAK/CBK
W1 Supporting point	kg 416	kg 423	kg 424
W2 Supporting point	kg 319	kg 327	kg 329
W3 Supporting point	kg 365	kg 374	kg 375
W4 Supporting point	kg 431	kg 439	kg 440
Operating weight	kg 1531	kg 1563	kg 1568
Shipping weight	kg 1531	kg 1563	kg 1568

The presence of optional accessories may result in a substantial variation of the weights shown in the table.

Size 33.4-40.4-44.4 Combustion module - CCK and CCKP configuration

Double chamber

DAA8F35-2_CCK-CCKP_GC12X_00
Date: 10/12/2014

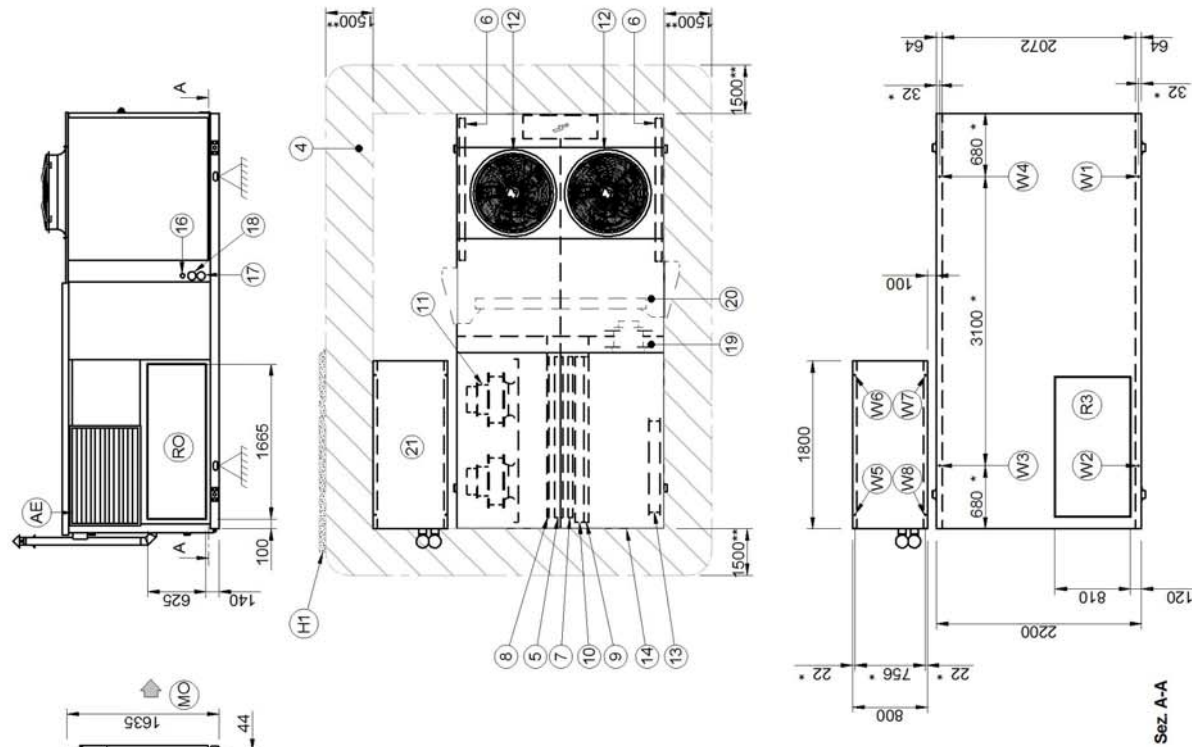

- 16. Humidifier connections
- 17. H2O heating coil input Ø 1"1/4 / Recovery from the food refrigeration Ø 2"
- 18. H2O heating coil output Ø 1"1/4 / Recovery from the food refrigeration Ø 2"
- 19. Exhaust electric fan
- 20. Exhaust air recovery coil (CCKP version)
- 21. Gas module

- (RO) Horizontal air return
- (R3) Floor air inlet (optional)
- (MO) Horizontal air supply
- (AE) Outdoor air return
- (H1) Wall with same height as unit on a maximum of three sides
- (**) Suggested clearance
- (*) Vibration mounts position

Size	33.4	40.4	40.4	44.4	44.4
Configuration	CCK	CCKP	CCK	CCKP	CCKP
W1 supporting point	kg 485	501	492	508	509
W2 Supporting point	kg 373	386	381	394	395
W3 Supporting point	kg 427	441	436	450	451
W4 Supporting point	kg 503	519	511	527	528
Operating weight	kg 1788	1847	1820	1879	1883
Shipping weight	kg 1788	1847	1820	1879	1883

GAS MODULE WEIGHT DISTRIBUTION

Size	33.4	40.4	44.4
W5 Supporting point	kg 90	90	90
W6 Supporting point	kg 78	78	78
W7 Supporting point	kg 78	78	78
W8 Supporting point	kg 90	90	90
Operating weight	kg 2124	2156	2161
Shipping weight	kg 1788	1820	1825

The presence of optional accessories may result in a substantial variation of the weights shown in the table.

Page intentionally left blank



CLIVET SPA

Via Camp Lonc 25, Z.I. Villapaiera - 32032 Feltre (BL) - Italy
Tel. + 39 0439 3131 - Fax + 39 0439 313300 - info@clivet.it

CLIVET UK LTD (Sales)

4 Kingdom Close, Segensworth East - Fareham, Hampshire - PO15 5TJ - United Kingdom
Tel. + 44 (0) 1489 572238 - Fax + 44 (0) 1489 573033 - info@clivet-uk.co.uk

CLIVET AIRCON LTD (Service and Maintenance Division)

Units F5&F6 Railway Triangle Ind Est, Walton Road - Portsmouth, Hampshire - PO6 1TG - United Kingdom
Tel. +44 (0) 2392 381235 - Fax. +44 (0) 2392 381243 - info@clivetaircon.co.uk

CLIVET ESPAÑA COMERCIAL S.L. (Sales)

Calle Gurb, 17 1º 1ª - 08500 Vic, Barcelona - España
Tel: +34 93 8606248 - Fax +34 93 8855392 - info@clivetcomercial.com

CLIVET ESPAÑA S.A.U. (Service and Maintenance Division)

Calle Real de Burgos Nº 12 - 28860 Paracuellos del Jarama, Madrid - España
Tel. +34 91 6658280 - Fax +34 91 6657806 - info@clivet.es

CLIVET GmbH

Hummelsbütteler Steindamm 84, 22851 Norderstedt - Germany
Tel. + 49 (0) 40 32 59 57-0 - Fax + 49 (0) 40 32 59 57-194 - info.de@clivet.com

CLIVET RUSSIA

Elektrozavodskaya st. 24, office 509 - 107023, Moscow, Russia
Tel. + 74956462009 - Fax + 74956462009 - info.ru@clivet.com

CLIVET MIDEAST FZCO

Dubai Silicon Oasis (DSO), High Bay Complex, Ind Unit No. 3, PO BOX 28178, Dubai, UAE
Tel. + 9714 3208499 - Fax + 9714 3208216 - info@clivet.ae

CLIVET AIRCONDITIONING SYSTEMS PRIVATE LIMITED

4BA, Gundecha Onclave - Kherani Road, Saki Naka, Andheri (East) - Mumbai 400 072 - India
Tel. +91 22 6193 7000 - Fax +91 22 6193 7001 - info.in@clivet.com