

# WSA-XEE 182-352

Air-water ductable liquid chiller for indoor installation



Dear Customer,

We congratulate you on choosing this product

For many years Clivet has been offering systems that provide maximum comfort, together with high reliability, efficiency, quality and safety.

The aim of the company is to offer advanced systems, that assure the best comfort, reduce energy consumption and the installation and maintenance cost for the life cycle of the system.

The purpose of this manual is to provide you with information that is useful from reception of the equipment, through installation, operational usage and finally disposal so that this advanced system offers the best solution.

Yours faithfully,

CLIVET Spa

The data contained in this manual is not binding and may be changed by the manufacturer without prior notice.

Reproduction, even in part, is FORBIDDEN © Copyright - CLIVET S.p.A. - Feltre (BL) - Italia

---

# Index of contents

1	General description	4
2	Reception	6
3	Positioning	9
4	Water connections	11
5	Electrical connections	15
6	Start-up	21
7	Control	29
8	Maintenance	40
9	Accessories	43
10	Decommissioning	49
11	Residual risks	50
12	Technical information	51

# 1 General description

## 1.1 Manual

The manual provides correct unit installation, use and maintenance.

Pay particular attention to:



Warning, identifies particularly important operations or information.



Prohibited operations that must not be carried out, that compromise the operating of the unit or may cause damage to persons or things.

- It is advisable to read it carefully so you will save time during operations.
- Follow the written indications so you will not cause damages to things and injuries people.

## 1.2 Preliminaries

Only qualified personnel can operate on the unit, as required by the regulation in force.

## 1.3 Risk situations



The unit has been designed and created to prevent injuries to people.

During designing it is not possible to plane and operate on all risk situation.

Read carefully "Residual risk" section where all situation which may cause damages to things and injuries to people are reported.

Installation, starting, maintenance and repair required specific knowledge; if they are carried out by inexperienced personnel, they may cause damages to things and injuries people.

## 1.4 Intended use

Use the unit only:

- for cooling/heating water or a water and glycol mix for air-conditioning only
- keep to the limits foreseen in the technical schedule and in this manual

The manufacturer accepts no responsibility if the equipment is used for any purpose other than the intended use.

## 1.5 Installation

Indoor installation



The positioning, hydraulic system, refrigerating, electrics and the ducting of the air must be determined by the system designer in accordance with local regulations in force.

Follow local safety regulations.

Verify that the electrical line characteristics are in compliance with data quotes on the unit serial number label.

## 1.6 Maintenance

Plan periodic inspection and maintenance in order to avoid or reduce repairing costs.



Turn the unit off before any operation.

## 1.7 Modification



All unit modifications will end the warranty coverage and the manufacturer responsibility.

## 1.8 Breakdown/Malfuction

Disable the unit immediately in case of breakdown or malfunction.

Contact a certified service agent.

Use original spares parts only.

Using the unit in case of breakdown or malfunction:

- voids the warranty
- it may compromise the safety of the unit
- may increase time and repair costs

## 1.9 User training



The installer has to train the user on:

- Start-up/shutdown
- Set points change
- Standby mode
- Maintenance
- What to do / what not to do in case of breakdown

## 1.10 Data update

Continual product improvements may imply manual data changes.

Visit manufacturer web site for updated data.

## 1.11 Indications for the User



Keep this manual with the wiring diagram in an accessible place for the operator.

Note the unit data label so you can provide them to the assistance centre in case of intervention (see "Unit identification" section).

Provide a unit notebook that allows any interventions carried out on the unit to be noted and tracked making it easier to suitably note the various interventions and aids the search for any breakdowns.

In case of breakdown or malfunction:

- Immediately deactivate the unit
- Contact a service centre authorized by the manufacturer



The installer must train the user, particularly on:

- Start-up/shutdown
- Set points change
- Standby mode
- Maintenance
- What to do / what not to do in case of breakdown

## 1.12 Unit identification

The serial number label is positioned on the unit and allows to identify all the unit features.

The matriculation plate shows the indications foreseen by the standards, in particular:

- unit type
- serial number (12 characters)
- year of manufacture
- wiring diagram number
- electrical data
- type of refrigerant
- refrigerant charge
- manufacturer logo and address



The matriculation plate must never be removed.



It contains fluorinated greenhouse gases

Type of refrigerant: R410A

## 1.13 Serial number

It identifies uniquely each unit.

Must be quoted when ordering spare parts.

## 1.14 Assistance request

Note data from the serial number label and write them in the chart on side, so you will find them easily when needed.

Series
Size
Serial number
Year of manufacture
Electrical wiring diagram

## 2 Reception

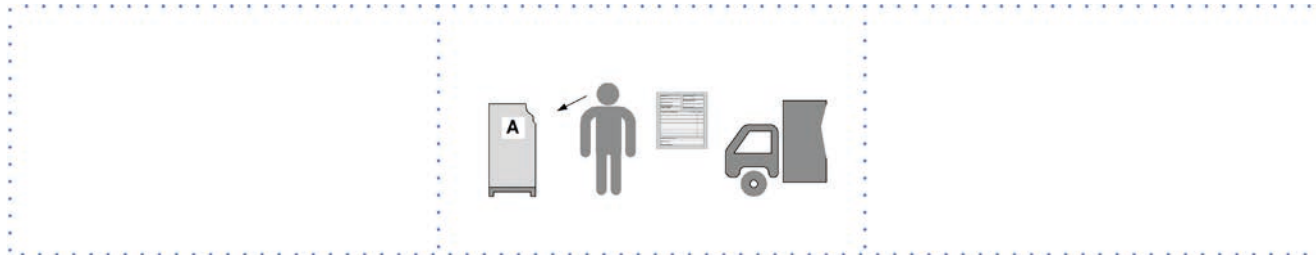

You have to check before accepting the delivery:

- That the unit hasn't been damaged during transport
- That the materials delivered correspond with that indicated on the transport document comparing the data with the identification label positioned on the packaging.

In case of damage or anomaly:

- Write down on the transport document the damage you found and quote this sentence: "Conditional acceptance clear evidence of deficiencies/damages during transport"
- Contact by fax and registered mail with advice of receipt to supplier and the carrier.



Any disputes must be made within 8 days from the date of the delivery. Complaints after this period are invalid.

### 2.1 Storage

Observe external packaging instructions.

### 2.2 Handling

- Verify unit weight and handling equipment lifting capacity.
- Identify critical points during handling (disconnected routes, flights, steps, doors).
- Suitably protect the unit to prevent damage.
- Align the barycenter to the lifting point
- Use all the lifting brackets (see the dimensional section)
- Gradually bring the lifting belts under tension, making sure they are positioned correctly.
- Before starting the handling, make sure that the unit is stable.

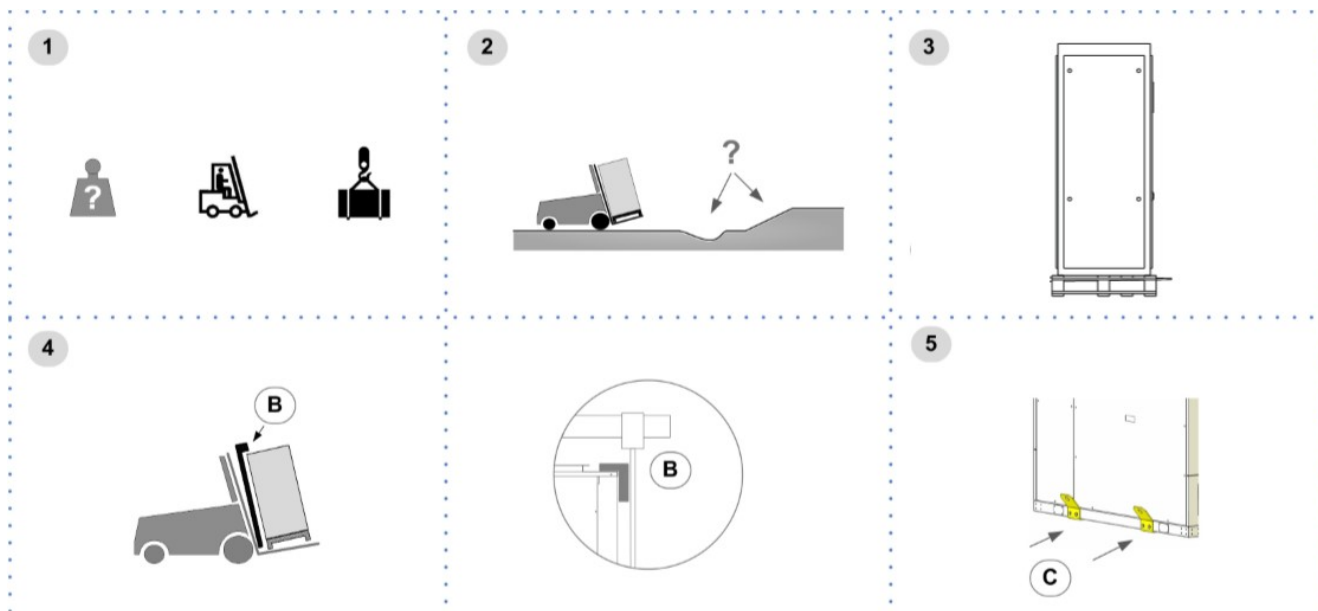

- B Protections
- C Additional lifting brackets (optional)

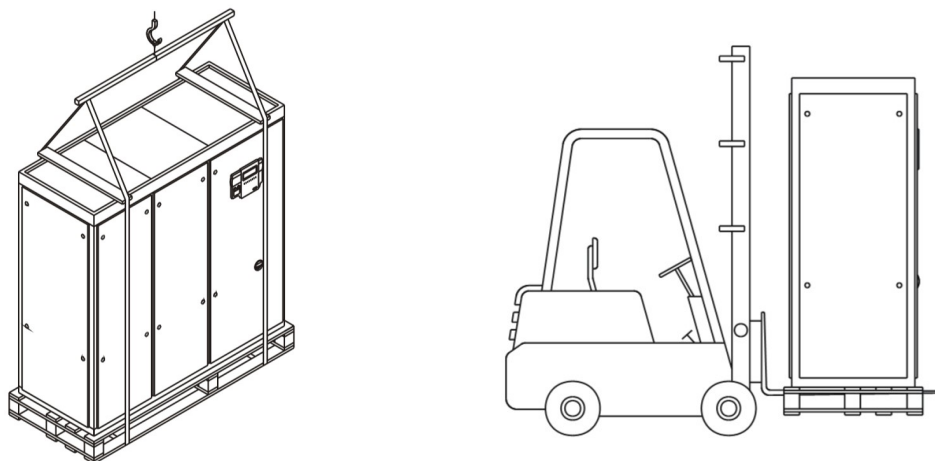

## 2.3 Packaging removing

Be careful not to damage the unit.

Keep packing material out of children's reach it may be dangerous.

Recycle and dispose of the packaging material in conformity with local regulations.

## 2.4 Removable fan section for shipping

Fan section weights

Size	Kg
182-222	125
262-352	180

1

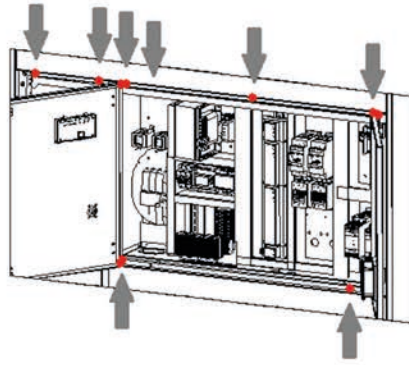
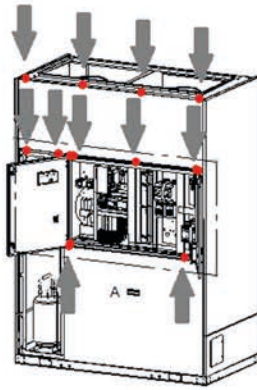

2

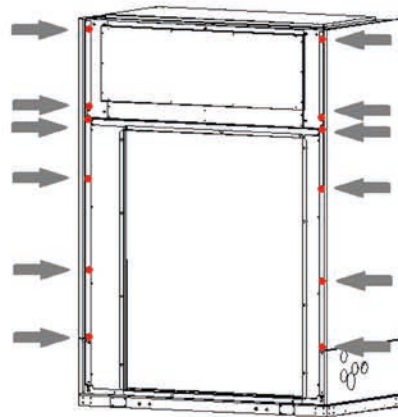
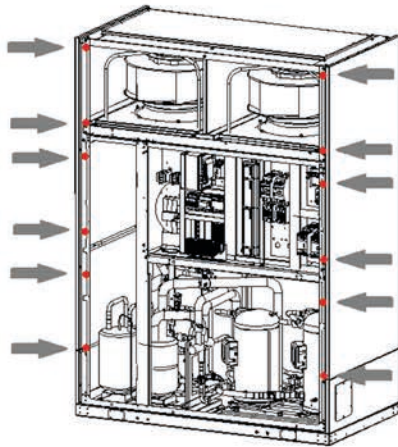

3

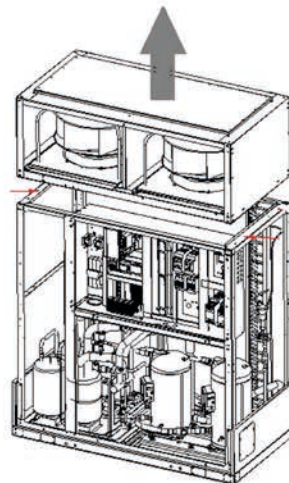
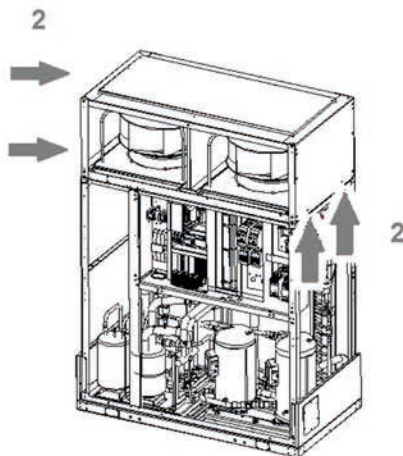



## 3 Positioning

During positioning consider these elements:

- Technical spaces requested by the unit
- Electrical connections
- Water connections
- Spaces for air exhaust and intake

### 3.1 Functional spaces

Functional spaces are designed to:

- guarantee good unit operation
- carry out maintenance operations
- protect authorized operators and exposed people

Respect all functional spaces indicated in the DIMENSIONS section.

Double all functional spaces if two or more unit are aligned.

### 3.2 Positioning



Units are designed to be installed:

- INTERNAL
- in fixed positions

Limit vibration transmission:

- use antivibration devices on unit bearing points
- install flexible joints on the hydraulic connections

Choose the installation place according to the following criteria:

- Customer approval
- safe accessible position
- technical spaces requested by the unit
- spaces for the air intake/exhaust
- max. distance allowed by the electrical connections
- avoid installations in places subject to flooding
- verify unit weight and bearing point capacity
- verify that all bearing points are aligned and leveled
- install the unit raised from the ground

A correct circulation of the air is mandatory to guarantee the good unit operating.



Avoid therefore:

- obstacles to the airflow
- difficulty of exchange
- leaves or other foreign bodies that can obstruct the air coil
- winds that hinder or favour the airflow
- heat or pollution sources close to the unit (chimneys, extractors etc..)
- stratification (cold air that stagnates at the bottom)
- recirculation (expelled air that is sucked in again)

Ignoring the previous indications could:

- reduce energy efficiency
- alarm lockout due to HIGH PRESSURE (in summer) or LOW PRESSURE (in winter)

### 3.3 Safety valve gas side

The installer is responsible for evaluating the opportunity of installing drain tubes, in conformity with the local regulations in force (EN 378).

### 3.4 Fresh air probe

For details see:

3.4 Fresh air probe p. 9

### 3.5 Air channelling

When designing and manufacturing the ducting, consider LOAD LOSSES, AIR FLOW AND SPEED that must be consistent with the unit features. Limit the load losses by optimising the path, the type and number of bends and junctions.



Consider that excessive external static pressure will lead to a reduction in flow rate, with consequent alarm lockout. Ensure ducts are thermally insulated.



The weight of the ducting must not burden the connection flanges.

Place anti-vibration joints between channels and unit.

Connection to the flanges and between the various sections of the channels must guarantee air seal, avoiding dispersions penalising the overall efficiency of the system.

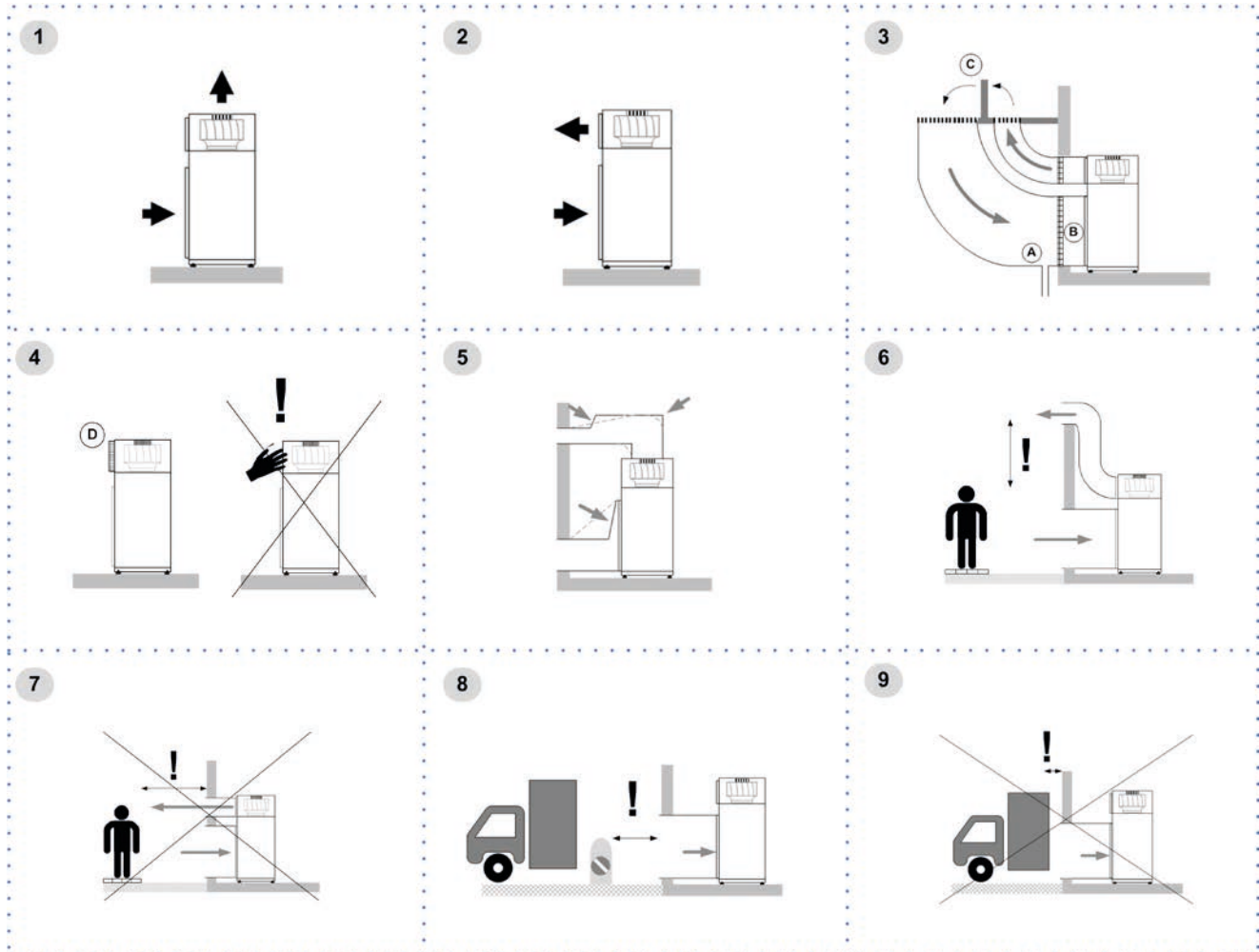

Vertical outlet standard (1)

Rear outlet option (2)

Provide:

- water discharge (3-A)
- grilles to restrict access to small animals (3-B)
- deflectors (3-C) to avoid the by-pass between the two air flows
- safety grille (4-D)

Avoid therefore:

- angle curves and narrowings (5)
- direct air flow on people (6-7), windows, doors, plants, obstacles in general
- obstacles that prevents the air inflow to the coil (8-9)
- installations next to silent rooms

## 4 Water connections

### 4.1 Water quality

Water features

- confirming to local regulations
- total hardness < 14°fr
- within the limits indicated by table

The water quality must be checked by qualified personnel.

Water with inadequate characteristics can cause:

- pressure drop increase
- reduces energy efficiency
- increased corrosion potential

Acceptable water quality values:

PH	7,5 ÷ 9,0	
SO <sub>4</sub> <sup>2-</sup>	< 100	ppm
HCO <sub>3</sub> <sup>-</sup> /SO <sub>4</sub> <sup>2-</sup>	> 1	
Total Hardness	4,5 ÷ 8,5	dH
Cl <sup>-</sup>	< 50	ppm
PO <sub>4</sub> <sup>3-</sup>	< 2,0	ppm
NH <sub>3</sub>	< 0,5	ppm

Free Chlorine	< 0,5	ppm
Fe <sub>3</sub> <sup>+</sup>	< 0,5	ppm
Mn <sup>++</sup>	< 0,05	ppm
CO <sub>2</sub>	< 50	ppm
H <sub>2</sub> S	< 50	ppb
Temperature	< 65	°C
Oxygen content	< 0,1	ppm

Provide a water treatment system if values fall outside the limits.



The warranty does not cover damages caused by limestone formations, deposits and impurities from the water supply and / or failure from failed system clearing to clean system.

### 4.2 Risk of freezing

If the unit or the relative water connections are subject to temperatures close to 0°C:

- mix water with glycol, or
- safeguard the pipes with heating cables placed under the insulation, or
- empty the system in cases of long non-use

### 4.3 Anti-freeze solution

The use of an anti-freeze solution results in an increase in pressure drop.



Make sure that the glycol type utilized is inhibited (not corrosive) and compatible with the water circuit components.



Do not use different glycol mixture (i.e. ethylene with propylene).

### 4.4 Water flow-rate

The project water-flow must be:

- inside the exchanger operating limits (see the TECHNICAL INFORMATION section)
- guarantee, also with variable system conditions (for example in systems where some circuits are bypassed in particular situations).

### 4.5 Minimum system water content

Minimum system water volumes are described within 'General technical data' section and they have to be satisfied to avoid continuous compressor switching on and off.

## 4.6 Recommended connection



The installer must define:

- component type
- position in system

Examples:

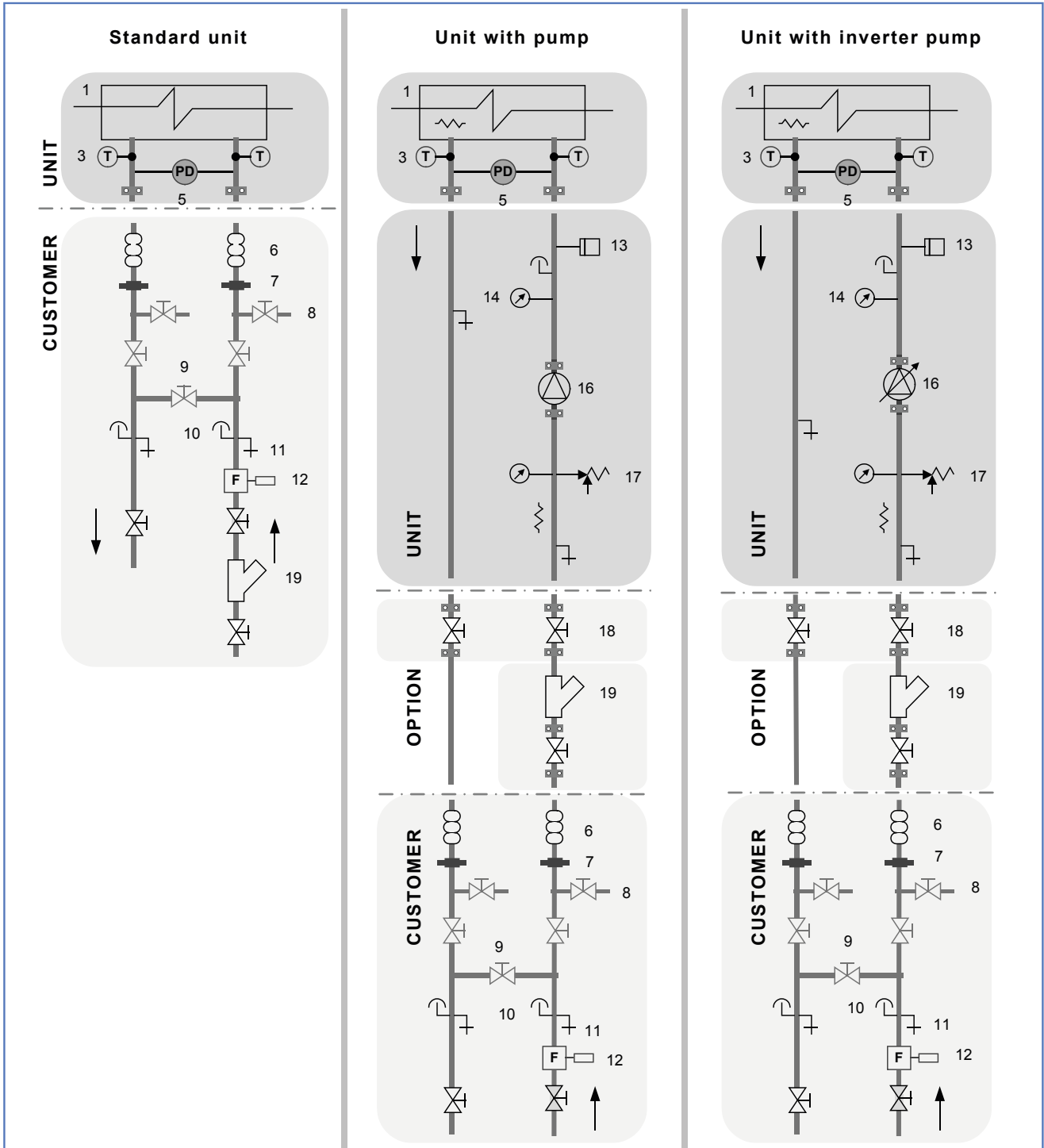

- |    |                                    |    |                                    |
|----|------------------------------------|----|------------------------------------|
| 1  | exchanger                          | 11 | drain                              |
| 3  | water temperature probe            | 12 | Flow Switch                        |
| 5  | differential pressure switch       | 13 | System load safety pressure switch |
| 6  | antivibration joints               | 14 | pressure gauge                     |
| 7  | pipng support                      | 15 | non-return valve                   |
| 8  | exchanger chemical cleaning bypass | 16 | Pump                               |
| 9  | Cleaning system bypass             | 17 | safety valve                       |
| 10 | vent                               | 18 | shut-off valve                     |
|    |                                    | 19 | filter                             |

## 4.7 Hydraulic connections

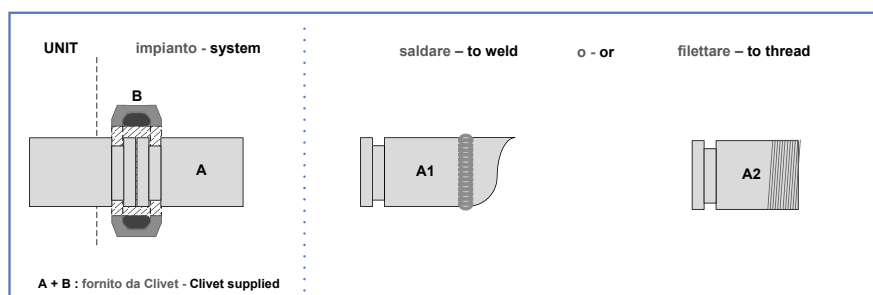

- ⊘ Do not weld the system pipe with the Victaulic connection joint attached. The rubber gasket might be irreparably damaged.

## 4.8 Water filter

- ⚠ Use filter with mesh pitch of 1,6 mm
- ⚠ It must be installed immediately in the water input of the unit, in a position that is easily accessible for cleaning.
- ⊘ The filter never should be removed, this operation invalidates the guaranty.

## 4.9 Flow Switch

The flow switch must be present to ensure shutdown of the unit if water is not circulating. It has to be installed in a duct rectilinear part, not in proximity of curves that cause turbulences.

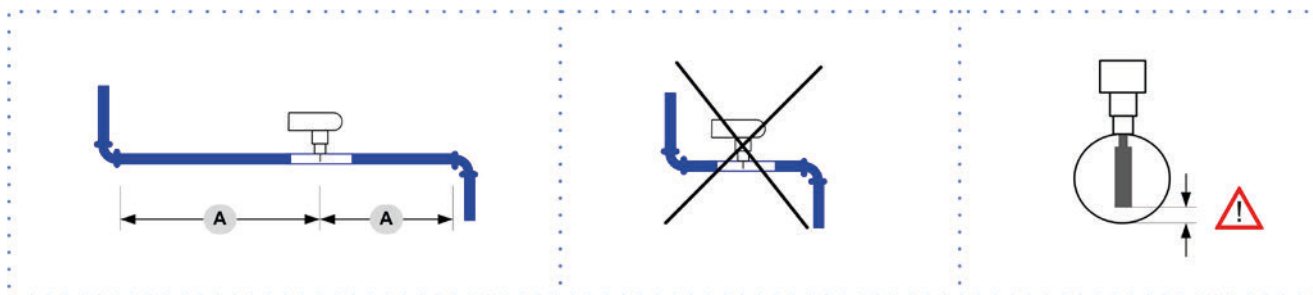

A. minimum distance

## 4.10 Operation sequence

Close all vent valves in the high points of the unit hydraulic circuit  
Close all drain valves in the low points of the unit hydraulic circuit:

- Heat exchangers
  - Pumps
  - collectors
  - storage tank
  - free-cooling coil
1. Carefully wash the system with clean water: fill and drain the system several times.
  2. Apply additives to prevent corrosion, fouling, formation of mud and algae.
  3. Fill the plant
  4. Execute leakage test.
  5. Isolate the pipes to avoid heat dispersions and formation of condensate.
  6. Leave various point of service free (wells, vent-holes etc).

- ⚠ Neglecting the washing will lead to several filter cleaning interventions and at worst cases can cause damages to the exchangers and the other parts.

### 4.11 Partial energy recovery

**Option**

A configuration which enables the production of hot water free-of-charge while operating in the cooling mode, thanks to the partial recovery of condensation heat that would otherwise be rejected to the external heat source.

The maximum capacity available from the partial recovery is equal to the 15% of the rejected heating capacity (cooling capacity + compressor power input)

- ⚠ The recovery exchanger must be always maintained full of water
- The lack of water amplifies the noise generated by the operation

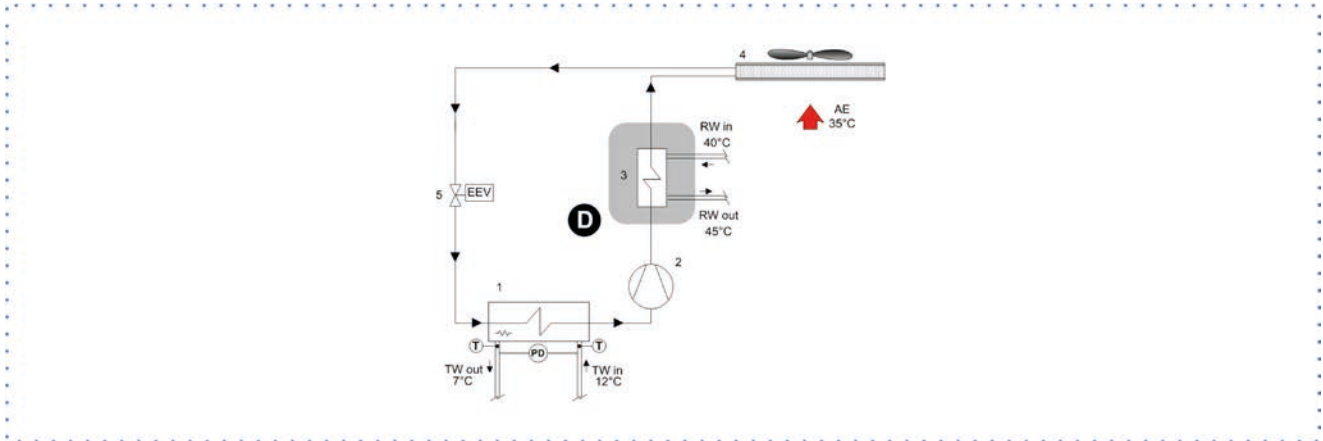

When the temperature of the water to be heated is particularly low, it is wise to insert a flow-rate control valve into the system water circuit, in order to maintain the temperature at the recovery output at above 35°C and thus avoid the condensation of the refrigerant into the partial energy recovery device.

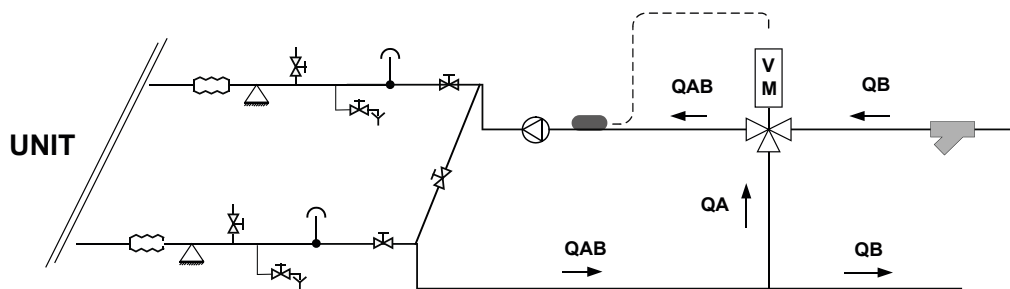

## 5 Electrical connections

The characteristics of the electrical lines must be determined by qualified electrical personnel able to design electrical installations; moreover, the lines must be in conformity with regulations in force.

The protection devices of the unit power line must be able to stop all short circuit current, the value must be determined in accordance with system features.

The power cables and the protection cable section must be defined in accordance with the characteristics of the protections adopted.

All electrical operations should be performed by trained personnel having the necessary qualifications required by the regulations in force and being informed about the risks relevant to these activities.

Operate in compliance with safety regulations in force.

### 5.1 Electrical data



The serial number label reports the unit specific electrical data, included any electrical accessories.

The electrical data indicated in the technical bulletin and in the manual refer to the standard unit, accessories excluded.

The matriculation plate shows the indications foreseen by the standards, in particular:

- Voltage
- F.L.A.: full load ampere, absorbed current at maximum admitted conditions
- F.L.I.: full load input, full load power input at max. admissible condition
- Electrical wiring diagram Nr.

### 5.2 Connections

1. Refer to the unit electrical diagram (the number of the diagram is shown on the serial number label).
2. Verify that the electrical supply has characteristics conforming to the data shown on the serial number label.
3. Before starting work, ensure the unit is isolated, unable to be turned on and a safety sign used.
4. Ensure correct earth connection.
5. Ensure cables are suitably protected.
6. Before powering up the unit, make sure that all the protections that were removed during the electrical connection work have been restored.

### 5.3 Signals / data lines

Do not exceed the maximum power allowed, which varies, according to the type of signal.

Lay the cables far from power cables or cables having a different tension and that are able to emit electromagnetic disturbances.

Do not lay the cable near devices which can generate electromagnetic interferences.

Do not lay the cables parallel to other cables, cable crossings are possible, only if laid at 90°.

Connect the screen to the ground, only if there aren't disturbances.

Guarantee the continuity of the screen during the entire extension of the cable.

Respect inductance, capacity and attenuation indications.

### 5.4 Power input



Fix the cables: if vacated may be subject to tearing.



The cable must not touch the compressor and the refrigerant piping (they reach high temperatures).

QS1: main isolator switch

XC: Customer connections

### 5.5 Remote ON-OFF



Do not perform short On Off cycles



Do not use the remote On Off with thermoregulation function.



## 5.6 Connections performer by customer

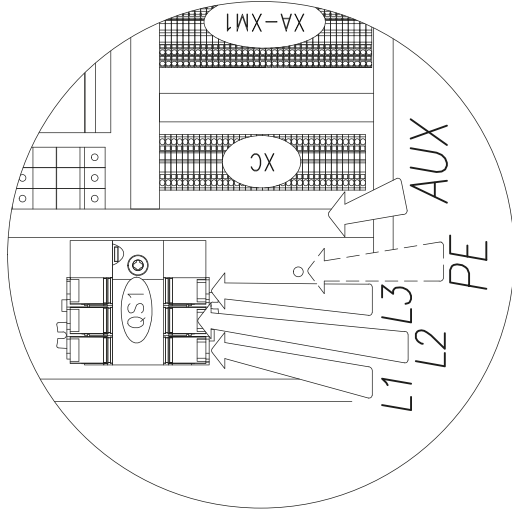

<b>HLC1-HLC2</b>	lampada di segnalazione stato compressore compressor status signal lamp lampe de signalisation état compresseur lámpara de señalización estado compresor
<b>HLE</b>	lampada di segnalazione stato CALDO indicating light of the HEAT status lampe di signalisation état CHAUD lámpara indicador estado CALIENTE
<b>ALM</b>	segnalazione bianca cumulativa cumulative alarm signal signalisation alarme señalización alarma acumulativa
<b>SA1</b>	selettore on/off remoto remote on/off selector Fernwahlschalter Ein/Aus selector on/off remoto
<b>SA1.1</b>	selettore abilitazione seconda set-point second set-point enabling switch Wahlschalter zweite konsigne selector habilitación segundo set-point
<b>SA5</b>	selettore remoto "estate/ inverno" remote water summer selector selettore d'été/hiver fernwahlschalter Winter/Sommer remoto verano/invierno
<b>SQ1</b>	flussstabilisator flow stabilizer contrôleur de débit Strommengenwähler flujostab
<b>QMP</b>	interuttore automatico a protezione pompa ricircolo automatic pump protection switch interrupteur automatique de protection pompe recirculation interruptor automático de protección bomba recirculación
<b>KMP</b>	contattore pompa di circolazione evaporatore evaporator pump contactor Schütz Kaltwasserpumpe contactor bomba de circulación evaporador
<b>APV</b>	uscita analogica 0...10V da elettronica per gestione evolo/ventilazione Free Cooling 0...10V analogical output from electronics for water/FREE-COOLING ventilation management Sortie analogique 0...10V de électronique pour gestion soupape/ventilation FREE-COOLING Salida analógica 0...10V de electrónica para gestión válvula/ventilación FREE-COOLING
<b>AP18</b>	demand limit demand limit demand limit demand limit
<b>AP19</b>	Water reset Water reset Water reset Water reset

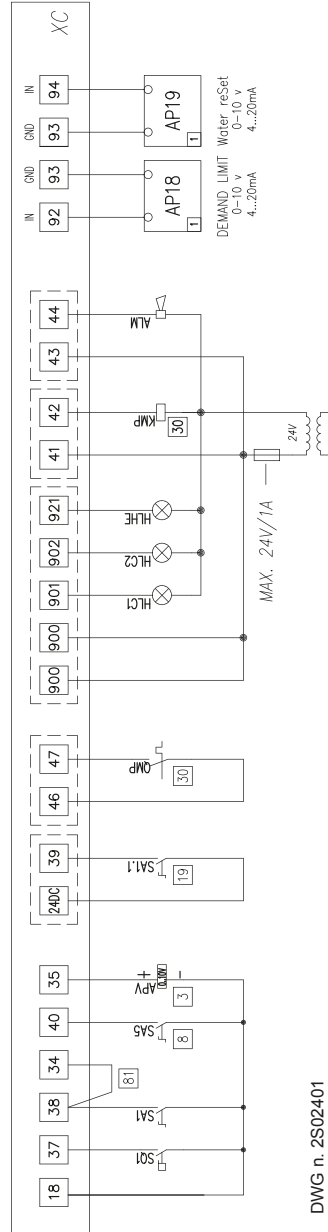

DWG n. 2S02401



## 5.7 Computer connection

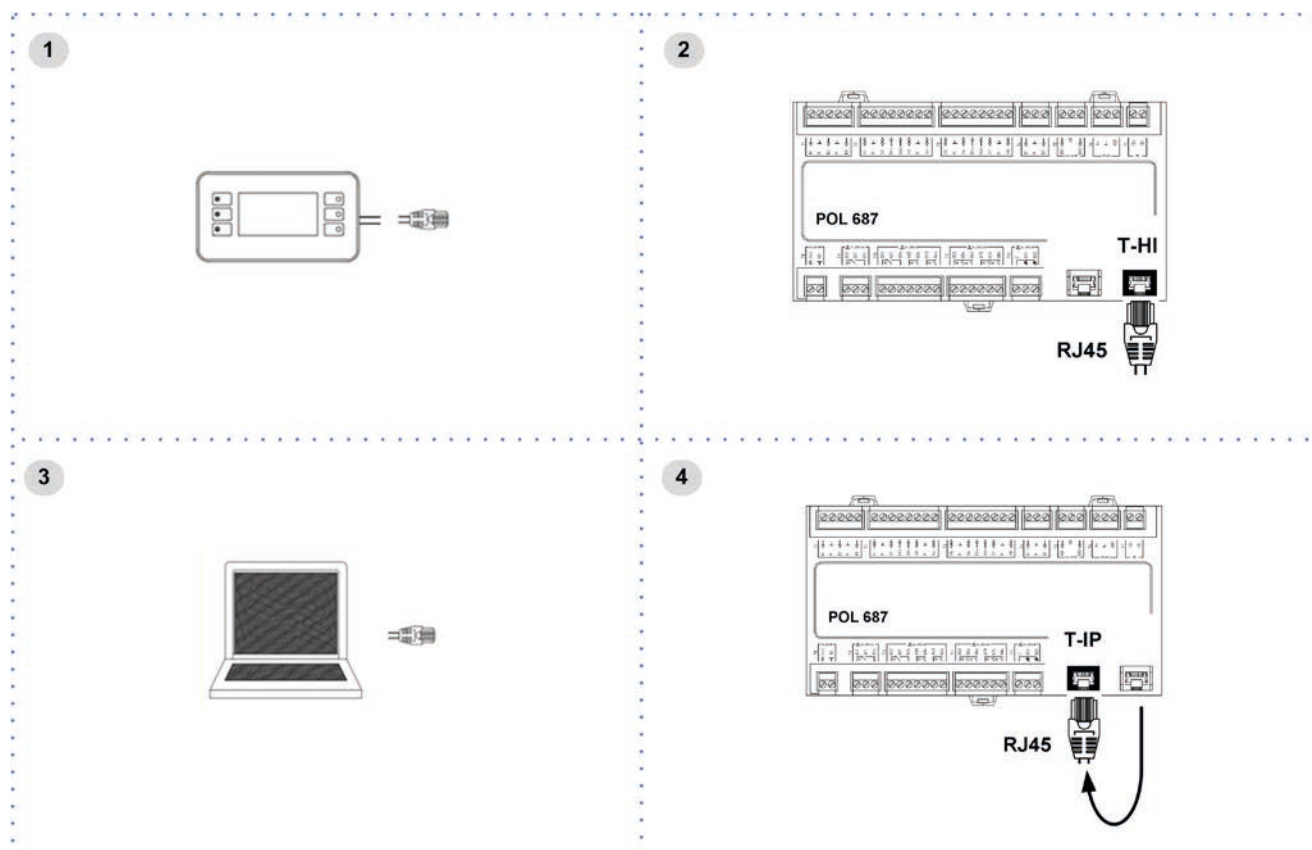

1. Service keypad
2. RJ45: standard connection
3. P.C.-not supplied
4. P.C. connection, shift RJ45 from T-HI to T-IP

### Configure P.C.

1. connect P.C. and main module with LAN cable
2. check in the taskbar that the connection is active
3. open Control Panel and select Network and sharing center
4. select Modify board setting
5. select Local area connection (LAN)
6. select Internet protocol version 4 (TCP) IPV4 and enter Property
7. set the IP address 192.168.1.100
8. set Subnet mask as 255.255.255.0
9. confirm (OK)
10. enter Start (Windows button)
11. write the command cmd and enter/do it
12. write and run the command Ping 192.168.1.42
13. the message, connection is OK, will appear when successful
14. enter the browser (Chrome, Firefox ecc)
15. write and run the command http://192.168.1.42
16. Userid = WEB
17. Password = SBTAdmin!

## 5.8 Remote control

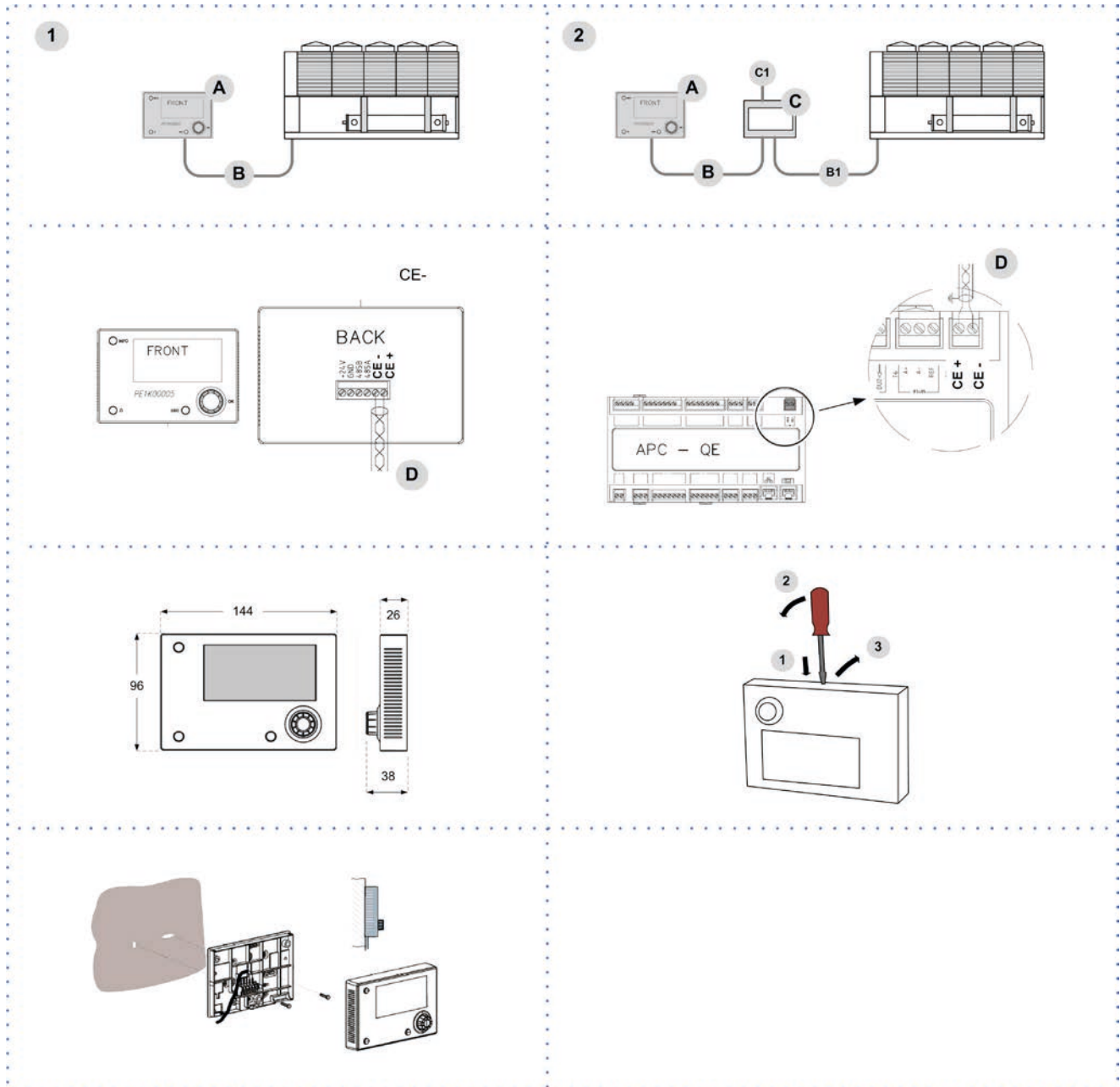

- 1 Distance up to 350 mt
- 2 Distance up to 700 mt

- A User interface
- B = B1 KNX bus, max 350 mt  
twisted pair with shield,  $\varnothing 0,8$  mm  
EIB/KNX cable marking recommende
- C PSX - Mains power supply unit  
pwer supply unit N125/11 5WG1 125-1AB11
- C1 AC 120...230V, 50...60Hz
- D KNX bus, max 350 mt

## 5.9 PSX - Mains power supply unit

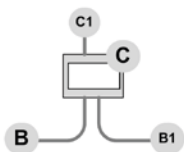

power supply unit N125/11 5WG1 125-1AB11

## 5.10 Modbus - RS485

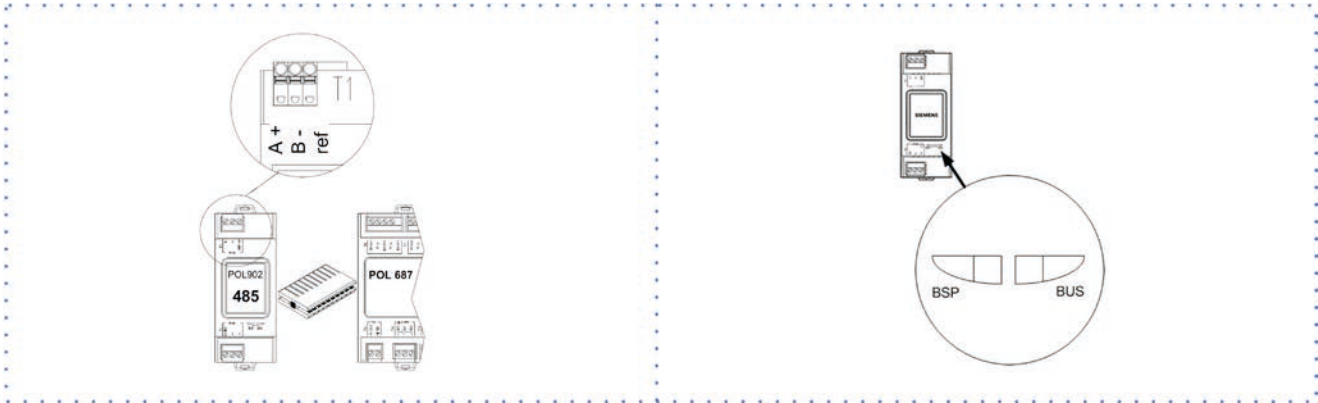

LED BSP	communication with AP1 module	LED BUS	communication with Modbus
green	communication ok	green	communication ok
yellow	software ok but communication with AP1 down	yellow	startup / channel not communicating
red	flashing: software error fixed: hardware error	red	communication down

Path

Main menu → Unit Parameters → Modbus

Parameters	Short description	Description
P0445:	T1 bus termination	Termination resistor activation on T1 POL902 [0] port = Passive [1] = Active
P0446:	T2 bus termination	Termination resistor activation on T2 POL902 [0] port = Passive [1] = Active



- Unit
- Metal conduit
- Metal septums
- Metal-lined sheath (sleeve)

### Modbus / LonWorks / Cable requirements

Couple of conductors twisted and shielded

Section of conductor 0,22mm<sup>2</sup>...0,35mm<sup>2</sup>

Rated power between conductors <math>\leq 50 \text{ pF/m}</math>

Nominal impedance 120  $\Omega$

Recommended cable BELDEN 3106A

- Every RS485 serial line must be set up using the 'In/Out' bus system.
- Other types of networks are not allowed, such as Star or Ring networks.
- The difference in potential between the earth of the two RS485 devices that the cable shielding needs to be connected to must be lower than 7 V
- There must be suitable arresters to protect the serial lines from the effects of atmospheric discharges
- A 120 ohm resistance must be located on the end of the serial line. Alternatively, when the last serial board is equipped with an internal terminator, it must be enabled using the specific jumper, dip switch or link.
- The cable must have insulation features and non-flame propagation in accordance with applicable regulations.
- The RS485 serial line must be kept as far away as possible from sources of electromagnetic interference.

## 5.11 LonWorks

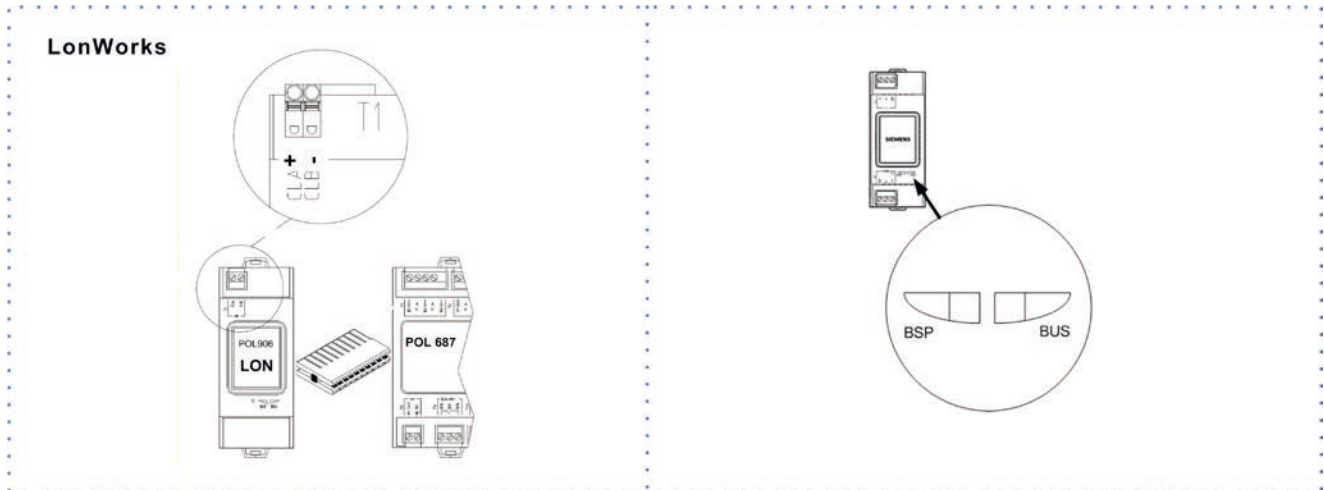

LED BSP	communication with AP1 module
green	communication ok
yellow	software ok but communication with AP1 down
red	flashing: software error fixed: hardware error

LED BUS	communication with LonWorks
green	ready for communication
yellow	startup
red	flashing: communicating not possible communication down

### LONWORK CABLE TYPES

Echelon allows three cable types for channel type TP/FT-10, including the

Category 5 network cable used commonly in building automation and control (TIA 568A Cat-5).

### CAT-5 SPECIFICATIONS

Unshielded cable, twisted pair with at least 18 beats per meter:

Cross-sectional area Min.  $\phi$  0.5mm, AWG24, 0.22mm<sup>2</sup>

Impedance 100  $\Omega$  +/- 15 % @  $f > 1$  MHz

Operating capacity between two wires of a pair < 46 nF/km

Capacity pair to ground, asymmetric. < 3.3 nF/km

DC loop resistance < 168  $\Omega$

## 5.12 BACnet IP

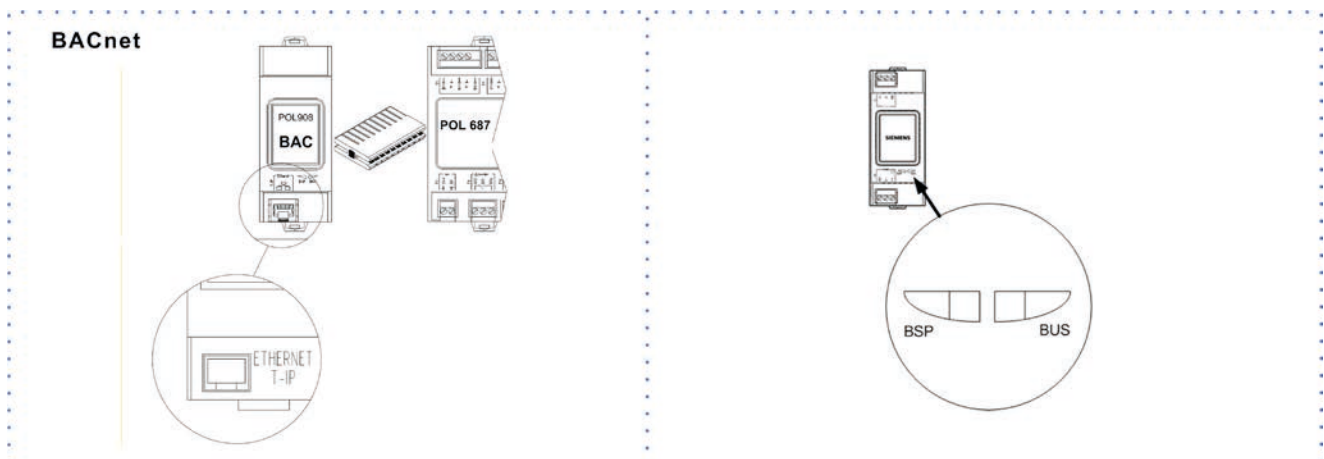

LED BSP	communication with AP1 module
green	communication ok
yellow	software ok but communication with AP1 down
red	flashing: software error fixed: hardware error

LED BUS	communication with BACnet
green	ready for communication
yellow	startup
red	BACnet server down restart after 3 sec

## 6 Start-up

### 6.1 General description

The indicated operations should be done by qualified technician with specific training on the product.

Upon request, the service centres performing the start-up.

The electrical, water connections and the other system works are by the installer.

Agree upon in advance the start-up data with the service centre.

Before checking, please verify the following:

- the unit should be installed properly and in conformity with this manual
- the electrical power supply line should be isolated at the beginning
- the unit isolator is open, locked and equipped with the suitable warning
- make sure no tension is present



After turning off the power, wait at least 5 minutes before accessing to the electrical panel or any other electrical component.



Before accessing check with a multimeter that there are no residual stresses.

### 6.2 Preliminary checks

For details refer to the different manual sections.

#### Unit OFF power supply

1. safety access
2. functional spaces
3. air flow: correct return and supply (no bypass, no stratification)
4. structure integrity
5. fans run freely
6. unit on vibration isolators
7. unit input water filter + shut-off valves for cleaning
8. vibration isolators on water connections
9. expansion tank (indicative volume = 5% system content)
10. Close all drain valves in the low points of the unit hydraulic circuit:
11. cleaned system
12. loaded system + possible glycol solution + corrosion inhibitor
13. system under pressure
14. vented system
15. fresh air probe
16. refrigerant circuit visual check
17. earthing connection
18. power supply features
19. electrical connections provided by the customer

### 6.3 Start-up sequence

For details refer to the different manual sections.

#### Unit ON power supply

1. compressor crankcase heaters operating at least since 8 hours
2. off-load voltage measure
3. phase sequence check
4. pump manual start-up and flow check
5. shut-off valve refrigerant circuit open
6. unit ON
7. load voltage measure and absorptions
8. liquid sight glass check (no bubbles)
9. check all fan operating
10. measure return and supply water temperature
11. measure super-heating and sub-cooling
12. check no anomalous vibrations are present
13. climatic curve personalization
14. climatic curve personalization
15. scheduling personalization
16. complete and available unit documentation

## 6.4 Refrigeration circuit

1. Check carefully the refrigerating circuit: the presence of oil stains can mean leakage caused by transportation, movements or other).
2. Verify that the refrigerating circuit is in pressure: Using the unit manometers, if present, or service manometers.
3. Make sure that all the service outlets are closed with proper caps; if caps are not present a leak of refrigerant can be possible.
4. Open the valves of the refrigerant circuit, if there are any.
5. Do not remove the seals on the compressor valves

## 6.5 Water circuit

1. Before realizing the unit connection make sure that the hydraulic system has been cleaned up and the cleaning water has been drained.
2. Check that the water circuit has been filled and pressurized.
3. Check that the shut-off valves in the circuit are in the "OPEN" position.
4. Check that there isn't air in the circuit, if required, evacuate it using the air bleed valve placed in the system high points.
5. When using antifreeze solutions, make sure the glycol percentage is suitable for the type of use envisaged.



Neglecting the washing will lead to several filter cleaning interventions and at worst cases can cause damages to the exchangers and the other parts.

Weight of glycol (%)	10	20	30	40
Freezing temperature (°C)	-3.9	-8.9	-15.6	-23.4
Safety temperature (°C)	-1	-4	-10	-19

## 6.6 Electric Circuit



Verify that the unit is connected to the ground plant.

Check the conductors are tightened as: the vibrations caused by handling and transport might cause these to come loose.

Connect the unit by closing the sectioning device, but leave it on OFF.

Check the voltage and line frequency values which must be within the limits: 400/3/50 +/- 10%

Check and adjust the phase balance as necessary: it must be lower than 2%

Example

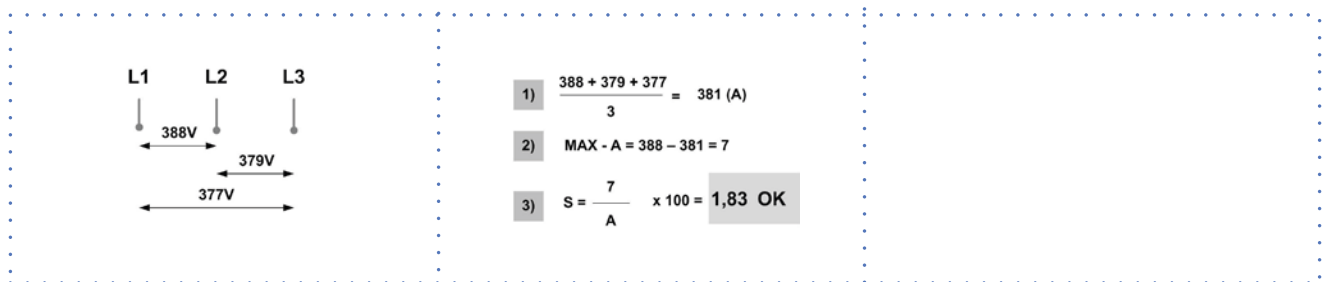

Working outside of these limits can cause irreversible damages and voids the warranty.

## 6.7 Compressor crankcase heaters

Connect the oil resistances on the compressor crankcase at least 8 hours before the compressor is to be starter:

- at the first unit start-up
  - after each prolonged period of inactivity
1. Supply the resistances switching off the unit isolator switch.
  2. To make sure that heaters are working, check the power input.
  3. At start-up the compressor crank-case temperature on the lower side must be higher at least of 10°C than the outside temperature.



Do not start the compressor with the crankcase oil below operating temperature.

## 6.8 Voltages

Check that the air and water temperatures are within in the operating limits.

Start-up the unit.

With unit operating in stable conditions, check:

- Voltage
- Total absorption of the unit
- Absorption of the single electric loads

## 6.9 Remote controls

Check that the remote controls (ON-OFF etc) are connected and, if necessary, enabled with the respective parameters as indicated in the “electrical connections” section.

Check that probes and optional components are connected and enabled with the respective parameters (“electrical connections” section and following pages).

## 6.10 Demand limit

⚠ Menu accessible only after having entered the password.

⚠ Access reserved only to specifically trained personnel.

⚠ The parameter modification can cause irreversible damages.

It is possible to limit the absorbed electric power with an external signal 0-10 Vcc or 4-20mA.

The higher the signal is, the lower the number of compressors available to meet the thermal need.

Only if P0050:En DemandLimit ≠ 0

Path: Main Menu / Unit parameters / Demand limit

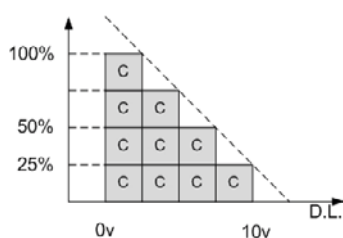

Step	Display	Action	Menu/Variable	Keys		Notes
1		Press 3 sec.		✓		
2	Password	Set	Password	▲	✓	
3		Press		i		
4	Main menu	Select	Unit parameters	▼	✓	
5	Unit parameters	Select	Set Point	▼	✓	
6	Set Point	Select	Demand limit	▼	✓	
7		Set	Demand limit	▲	▼	
8		Confirm		✓		
9		Press 3 sec.		⏏		
10		Select	Local connections	✓		

Path: Main Menu / Unit parameters / Demand limit

Parameters	Short description	Description
P0009:	set demand limit	Parameter setting of the value % of demand limit
P0062	TypeDL	Inlet signal type: 0=0-10V; 1=4-20mA

## 6.11 Climatic TExt

- Menu accessible only after having entered the password.
  - Access reserved only to specifically trained personnel.
  - The parameter modification can cause irreversible damages.
- The setpoint defined by the temperature curve is shown at status S0010: ActualSptTExt  
 Only if P0053: En Climatica ≠ 0  
 Path: Main Menu / Unit parameters / Climatica TExt  
 Example

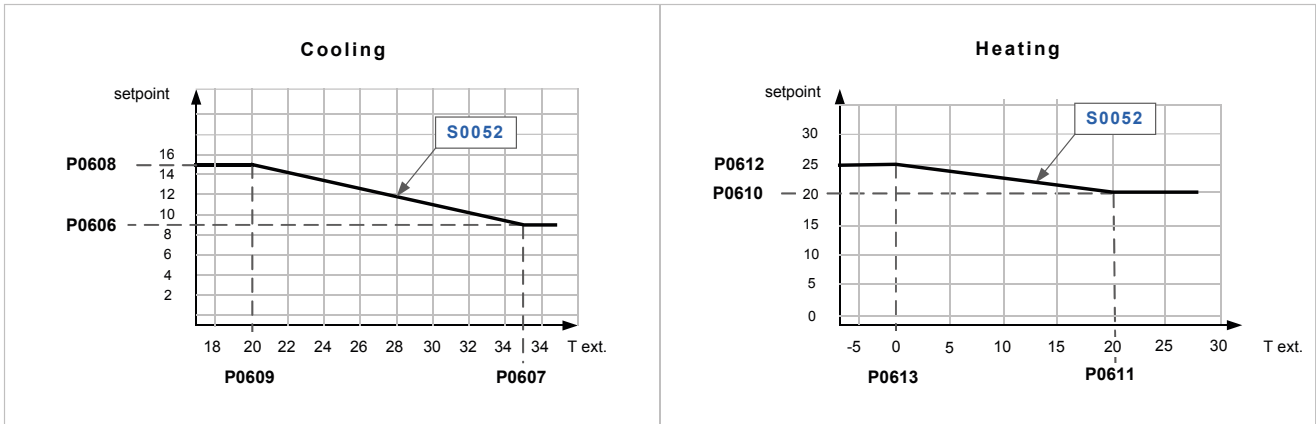

Step	Display	Action	Menu/Variable	Keys		Notes
1		Press 3 sec.				
2	Password	Set	Password			
3		Press				
4	Main menu	Select	Unit parameters			
5	Unit parameters	Select	Climatic TExt			
6	Climatic TExt (pwd)	Select	Parameter			
7		Set				
8		Confirm				
9		Press 3 sec.				
10		Select	Local connections			

Path: Main Menu / Unit parameters / Climatica TExt

Parameters	Short description	Description
P0265:	CSptLow	setpoint temperature value when the air temperature value is AirAtSptLowC
P0266:	AirAtSptLowC	external air temperature value where the calculated setpoint takes on the value given by SptLowC
P0267:	CSptHigh	setpoint temperature value when the air temperature value is AirAtSptHigC
P0268:	AirAtSptHigC	external air temperature value where the calculated setpoint takes on the value given by SptHigC



## 6.12 Water reset

- ⚠ Menu accessible only after having entered the password.
- ⚠ Access reserved only to specifically trained personnel.
- ⚠ The parameter modification can cause irreversible damages.  
It is possible to limit the absorbed electric power with an external signal 0-10 Vcc or 4-20mA.  
The water reset correction affects the setpoint defined by the Climate curve TExt (actual setpoint).  
The setpoint is shown at status S0011: ActualSptWR  
Only if P0051: En WaterReset ≠ 0  
Path: Main Menu / Unit parameters / Water reset

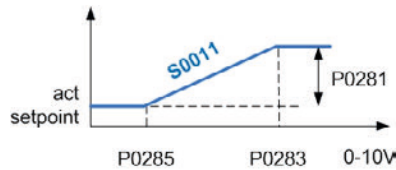

Step	Display	Action	Menu/Variable	Keys		Notes
1		Press 3 sec.		✓		
2	Password	Set	Password	▼	✓	
3		Press		i		
4	Main menu	Select	Unit parameters	▼	✓	
5	Unit parameters	Select	Water reset	▼	✓	
6	Water reset	Select	Parameter	▼	✓	
7		Set		▼	▲	
8		Confirm		✓		
9		Press 3 sec.		⏏		
10		Select	Local connections	✓		

Path: Main Menu / Unit parameters / Water reset

Parameters	Short description	Description
P0063	TypeWR	Inlet signal type: 0=0-10V; 1=4-20mA
P0281:	MaxCWRC	Maximum correction to be applied to the setpoint
P0283:	SWRMaxC	Value of the WR control signal corresponding to the correction of the set COOL equal to the parameter P0281
P0285	SWRMinC	Value of the WR control signal corresponding to the correction of the set COOL equal to 0

### 6.13 ECOSHARE function for the automatic management of a group of units

- Max 7 units
- Maximum length of the bus line: 1000 m.
- Maximum distance between 2 units: 700 m.
- Type of cable: shielded twisted pair cable Ø 0,8 mm. use an EIB/KNX cable
- Possible connections: Tree, star, in/out bus, mixed
- It is not possible to use a ring connection
- No end-of-line resistor or terminator required
- There must be suitable arresters to protect the serial lines from the effects of atmospheric discharges
- The data line must be kept separate from the power conductors or powered at different voltage values and away from possible sources of electrical interference

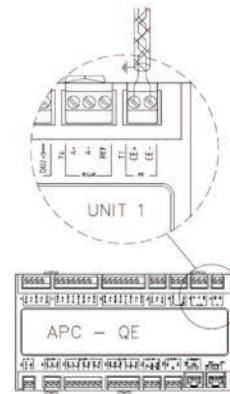
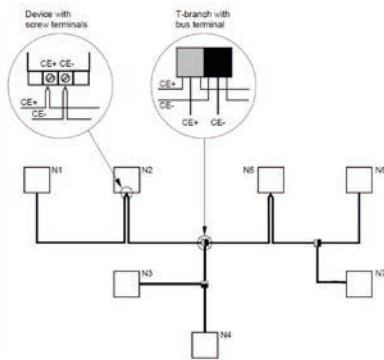

Tree topology (with stub lines)

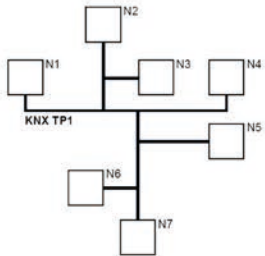

Line topology (with loops)

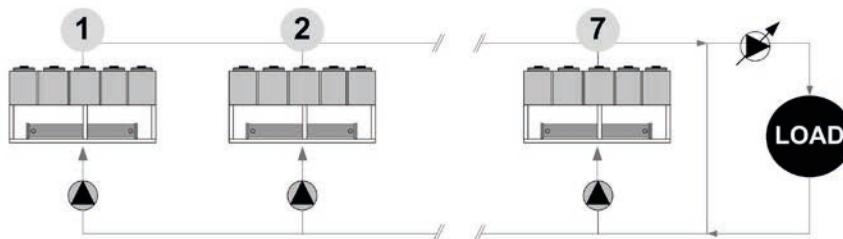
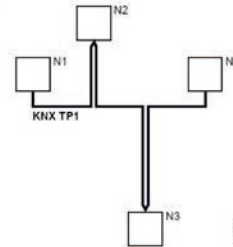

If there are more units connected in a local network set the mode of operation.

### MODE A

Every unit manages its own compressors according to the setpoint.

Every unit optimizes its refrigeration circuits.

Pumps always active, even with compressor stoped.

P0343 = 0

P0344 > 0 °C

setpoint1 > setpoint2 > setpoint3

or

setpoint1 < setpoint2 < setpoint3

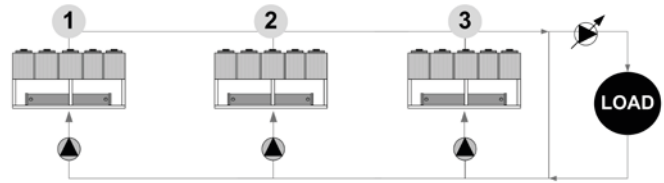

### MODE B

The master manages the single cooling.

The master optimizes individual refrigerant circuits.

Pumps always active, even with compressor stoped.

P0343 = 1

P0344 = 0 °C

setpoint1 = setpoint2 = setpoint3

plus: optimal H2O temperature control

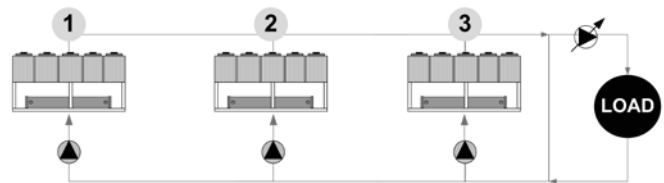

### MODE C

The master manages the single cooling.

The master optimizes individual refrigerant circuits.

Active pumps only with active compressors.

P0343 = 2

P0344 = 0 °C

setpoint1 = setpoint2 = setpoint3

plus: minimum pumps consumption need balanced system (t1 = t2 = t3)

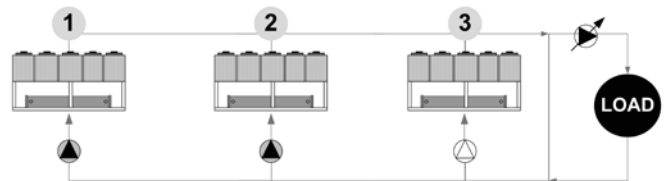

Path: Main Menu / Unit parameters / Master Slave

Parameters	Short description	Description
P0340:	Address unit	ProcessBus address unit
P0341:	Unit network	Number of network-connected units including the master
P0342:	Standby unit	Number of units kept in standby
P0343:	TypeRegMS	Operation mode: 0=mode A; 1=mode B; 2=mode C
P0344:	Offset Trm MS	Temperature Offset the master sum or subtract, depending on the way you set, in order of priority, to the set point of the slave

## 6.14 Evaporator water flow-rate

Check that the difference between the temperature of exchanger return and supply water corresponds to power according to this formula:

unit cooling power (kW) x 860 = Dt (°C) x flow rate (L/h)

The cooling power is shown in the table of the GENERAL TECHNICAL DATA included in this manual, referred to specific conditions, or in the tables on COOLING PERFORMANCE in the TECHNICAL BULLETIN referred to various conditions of use.

Check for water side exchanger pressure drops:

determine the water flow rate

measure the difference in pressure between exchanger input and output and compare it with the graph on WATER SIDE EXCHANGER PRESSURE DROPS

The measurement of pressure will be easier if pressure gauges are installed as indicated in the DIAGRAM OF SUGGESTED WATER CONNECTIONS.

## 6.15 Operating at reduced load

The units are equipped with partialization steps and they can, therefore, operate with reduced loads.

However a constant and long operation with reduced load with frequent stop and start-up of the compressor/s can cause serious damages for the lack of oil return.

The above-described operating conditions must be considered outside the operating limits.

In the event of compressor breakdown, due to operating in the above-mentioned conditions, the guarantee will not be valid and Clivet spa declines any responsibility.

Check periodically the average operating times and the frequency of the compressors starts: approximately the minimum thermal load should be such as to need the operating of a compressor for at least ten minutes.

If the average times are close to this limit, take the proper corrective actions.

## 6.16 Scroll compressor

The Scroll compressors have only one rotation direction.

In the event it is reversed, the compressor is not immediately damaged, but increases its noise and jeopardises pumping.

After a few minutes, the compressor blocks due to intervention of the thermal protection.

In this case, disconnect power supply and invert 2 phases on the machine power supply.

Avoid the compressor working for a long time with contrary rotation: more than 2-3 of these anomalous start-ups can damage it.

To ensure the rotation direction is correct, measure the condensation and suction pressure.

The pressures must significantly differ: upon start-up, the suction pressure decreases whereas the condensation one, increases.

## 6.17 Start-up report

Identifying the operating objective conditions is useful to control the unit over time.

With unit at steady state, i.e. in stable and close-to-work conditions, identify the following data:

- total voltages and absorptions with unit at full load
- absorptions of the different electric loads (compressors, fans, pumps etc)
- temperatures and flows of the different fluids (water, air) both in input and in output from the unit
- temperature and pressures on the characteristic points of the refrigerating circuit (compressor discharge, liquid, intake)

The measurements must be kept and made available during maintenance interventions.

## 6.18 2014/68/UE PED directive

DIRECTIVE 2014/68/UE PED gives instructions for installers, users and maintenance technicians as well.

Refer to local regulations; briefly and as an example, see the following:

Compulsory verification of the first installation:

- only for units assembled on the installer's building site (for ex. Condensing circuit + direct expansion unit)

Certification of setting in service:

- for all the units

Periodical verifications:

- to be executed with the frequency indicated by the Manufacturer (see the "maintenance inspections" paragraph)

## 7 Control

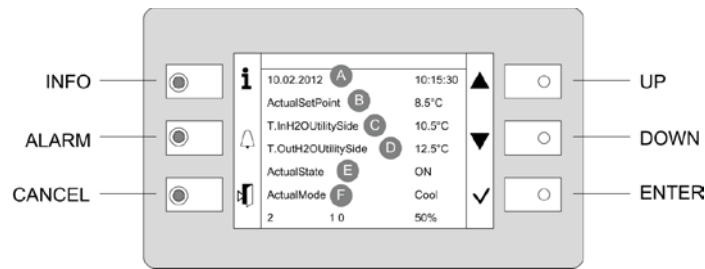

### 7.1 Led

INFO	Not used
ALARM	Blink / fixed = alarm present
CANCEL	not used currently

### 7.2 Display

Ref.	Variable	Description
A		Date - Time
B	<b>ActualSetPoint</b>	Temperature setting
C	<b>T.InH2OutilitySide</b>	Water inlet temperature utility side
D	<b>T.OutH2OutilitySide</b>	Water outlet temperature utility side
E	<b>ActualState</b>	On / off / eco / pmp On
F	<b>ActualMode</b>	Cool: water cooling Heat: Heating (not used)
	2	Installed compressors
	1 - 0	Compressors ON example: circuit 1 = 1 compr. On circuit 2 = 0 compr. On
	50%	Heating capacity

### 7.3 Keys

Symbol	Name	Description
	Info	Main menu
	Alarm	Alarm display
	Cancel	Exit Previous level Keyboard settings
	Up	Increases value
	Down	Decreases value
	Enter	Confirm Password

## 7.4 Change unit state

Step	Display	Action	Menu/Variable	Keys		Notes
1		Press				
2	Main menu	Select	Cmd Local state			
3		Set	OFF - ECO - ON - Pump On			*
4		Confirm				
6		Exit				

\* Local state

ECO: recurrent pump ON-OFF; compressors keep water system at setpoint ECO

Pmp ON: pump ON, compressor OFF

## 7.5 Change the mode

Step	Display	Action	Menu/Variable	Keys		Notes
1		Press				
2	Main menu	Select	Cmd Local mode			
3		Set	Cool: water cooling Heat: water heating (option)			
4		Confirm				
5		Exit				

## 7.6 Modify setpoint

Step	Display	Action	Menu/Variable	Keys		Notes
1		Press				
2	Main menu	Select	Unit parameters			
3	Unit parameters	Confirm	Set Point			
4		Select	Set Point			
5		Set	Set Point			
6		Confirm				
7		Exit				

Parameters	Short description	Description	
P0001	SetPoint Cool	Setpoint Cool	
P0002	SetPoint Heat	Setpoint Heat	Not used
P0003	2°SetPoint Cool	2° Setpoint Cool	Enable by remote switch
P0004	2°SetPoint Heat	2° Setpoint Heat	not used currently
P0005	SetPoint ECOCool	Economic summer SetPoint	
P0006	SetPoint ECOHeat	Economic winter SetPoint	Not used
P0007	SetPointRec	Recovery Set Point	

## 7.7 Scheduler

It is possible to set 6 events (Off, Eco, On, Recirculating) for each week day.

Step	Display	Action	Menu/Variable	Keys		Notes
1		Press				
2	Main menu	Select	Scheduler			
3	Scheduler	Select	Day			
4		Select	Time			
5		Set	Event time			
6		Confirm				
7		Select	Value			
8		Set	On/Eco..			
9		Confirm				
10		Exit				

### Enable Scheduler

Step	Display	Action	Menu/Variable	Keys		Notes
1		Press 3 sec.				
2	Password	Set	Password			
3		Press				*
4	Main menu	Select	Unit Parameters			
5		Select	Option config			
6		Set	P0061=1			
7		Press 3 sec.				
		Select	Local connections			

\* Unit Parameters menu is displayed

## 7.8 Keyboard settings

Step	Display	Action	Menu/Variable	Keys		Notes
1		Press 3 sec.				
2		Press				
3	HMI Settings	Select				
4		Press				
5		Press				
6		Select	Local connections			

## 7.9 Alarms



Before resetting an alarm identify and remove its cause.

Repeated resets can cause irreversible damage.

Example:

+ eE001: Monitore fase: Fault = active alarm

- EE003: Guasto P1 Util: Ok = resetted alarm

Display of alarm: step 1-3

Reset allarm: step 4-10

Step	Display	Action	Menu/Variable	Keys		Notes
1		Press				
2	Alarm list detail	Press				
3	Alarm list	Select	Alarm			
4	Alarm list detail	Press 3 sec.				
5	Password	Set	Enter password			
6	Alarm list detail	Press				
7	Alarm list	Select	Alarm			
8		Select	Reset Executed			
9		Press 3 sec.				
10	Password management	Select	Log off			

The alarm code identifies the concerned circuit:

Example:

ee 1 01:TimeOutModCirc = circuit 1

ee 2 01:TimeOutModCirc = circuit 2

The number of refrigerant circuits depends on series and size of the unit.

### t.i. input type:

DI = digital input

AI = analogic input

### Module:

687 = main module

985 = circuit module

94U = thermostatic driver module

### Input:

Connector number:

T1, T2, T3.....

PIN code:

X1, X2, Q13, DO1.....

### t.a. alarm type:

A automatic reset

M manual reset

A/M automatic reset, (after N alarm interventions becomes manual reset)

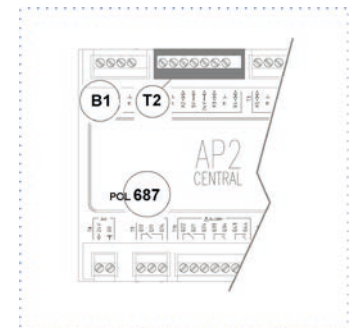









code	detailed description	t.i.	module	input	t.a.
eE001	Phase monitor	DI	687 central	T13 DL1	A/M
EE003	Pump 1 overload	DI	687 central	T13 DL2	M
EE004	Pump 2 overload	DI	687 central	T4 D1	M
EE005	Pump 3 overload	DI	687 central	T13 DL2	M
ee010	Master Offline - Master Slave network enabled				A
ee011	Unit 2 in alarm - Master Slave network enabled				A
ee012	Unit 2 OffLine - Master Slave network enabled				A
ee013	Unit 3 in alarm - Master Slave network enabled				A
ee014	Unit 3 OffLine - Master Slave network enabled				A
ee015	Unit 4 in alarm - Master Slave network enabled				A
ee016	Unit 4 OffLine - Master Slave network enabled				A
ee017	Unit 5 in alarm - Master Slave network enabled				A
ee018	Unit 5 OffLine - Master Slave network enabled				A
ee019	Unit 6 in alarm - Master Slave network enabled				A
ee020	Unit 6 OffLine - Master Slave network enabled				A
ee021	Unit 7 in alarm - Master Slave network enabled				A
ee022	Unit 7 OffLine - Master Slave network enabled				A
EE023	Pump 1 thermal protection	DI	965 hydronic	T1 X4	M
EE024	Pump 2 thermal protection	DI	965 hydronic	T1 X5	M
EE025	Pump 3 thermal protection	DI	965 hydronic	T1 X6	A
EE026	Inverter thermal protection	DI	965 hydronic	T5 DL1	A
ee027	Water inlet temperature probe faulty	AI	687 central	T1 B1	A
ee028	Water outlet temperature probe faulty	AI	687 central	T1 B2	A
ee029	External air temperature probe faulty	AI	687 central	T1 B3	A
ee030	Signal logoff or short circuit	AI	687 central	T2 X1	A
ee031	Signal logoff or short circuit	AI	687 central	T2 X2	A
ee032:	External Humidity probe faulty	AI	687 central	T2 X3	A
ee033:	Cabinet temperature probe faulty	AI	687 central	T2 X4	A
ee034:	Hydronic module on the ProcessBus is disconnected			peripheral bus	A
ee035:	Cool opening valve: error limit	DI	945 4P	X2	A
ee036:	Heat opening valve: error limit	DI	945 4P	X4	A
ee037:	Cool closing valve: error limit	DI	945 4P	X1	A
ee038:	Heat closing valve: error limit	DI	945 4P	X3	A
ee039:	Communication timeout 4P module	Logico	945 4P	peripheral bus	A
ee040:	FCI module water temperature probe fault	AI	955 FCI	X1	A
ee041:	Communication timeout FCI module	Logico	955 FCI	peripheral bus	A
EE044:	FCI module P1 thermal protection	DI	955 FCI	X5	M
EE045:	FCI module P2 thermal protection	DI	955 FCI	X6	M
EE046:	FCI module P3 thermal protection	DI	955 FCI	X7	M
ee050:	User side exchanger, differential pressure probe fault		965 hydronic	X3	A
ee054:	Recovery pump thermal protection	DI	955 FCI	X6	A
ee101:	Circuit 1 module on the ProcessBus is disconnected			peripheral bus	A
ee102:	Driver 1 module on the ProcessBus is disconnected			peripheral bus	A
ee103:	Recovery 1 module on the ProcessBus is disconnected			peripheral bus	A
ee104:	Driver 1 blocked		94U driver		A
EE106:	Compressor 1 thermal protection	DI	985 circuit 1	T4 D1	M
EE107:	Compressor 2 thermal protection	DI	985 circuit 1	T4 D2	M
EE108:	Compressor 3 thermal protection	DI	985 circuit 1	T4 D3	M
EE118:	Source side protection	DI	985 circuit 1	T9 DL2	M
ee122:	Faulty probe - discharge temperature compressor 1	AI	985 circuit 1	T1 B1	A
ee123:	Faulty probe - discharge temperature compressor 2	AI	985 circuit 1	T1 B2	A
ee124:	Faulty probe - discharge temperature compressor 3	AI	985 circuit 1	T2 X2	A
ee125:	Faulty probe - source 1 temperature	AI	985 circuit 1	T1 B3	A

code	detailed description	t.i.	module	input	t.a.
ee126:	Faulty probe - source 2 temperature	AI	985 circuit 1	T2 X1	A
ee127:	Faulty probe - Suction temperature	AI	94U driver	T2 X2	A
ee128:	Faulty probe - discharge pressure	AI	985 circuit 1	T2 X3	A
ee129:	Faulty probe - suction pressure	AI	94U driver	T1 X1	A
ee130:	Faulty probe - Recovery gas temperature	AI	965 recovery	T1 X1	A
ee131:	Faulty probe - Recovery pressure	AI	965 recovery	T2 X7	A
ee132:	Faulty probe - Water recovery inlet	AI	965 recovery	T1 X2	A
ee133:	Faulty probe - Water recovery outlet	AI	965 recovery	T1 X3	A
ee135:	Bios wrong version		985 circuit 1		A
ff105:	Low overheating Thermostatic C1				A
ff109:	Low pressure from analogic input	DI	985 circuit 1	T3 X7	A/M
ff110:	Pre-alarm - low pressure COOL mode				A
ff111:	Pre-alarm - low pressure HEAT mode				A
ff112:	Low pressure from analogic input	AI	94U driver	T1 X1	A/M
ff113:	High pressure from digital input	DI	985 circuit 1	T3 X8	A/M
ff114:	Pre-alarm - high pressure				A
ff115:	High pressure from analogic input	AI	985 circuit 1	T2 X3	A/M
ff116:	Pre-alarm max. compression ratio (high pressure / low pressure)				A
ff117:	Min. compression ratio (high pressure / low pressure)				A/M
FF119:	Alarm max. compression ratio (high pressure / low pressure)				M
FF134	Empty circuit	AI	94U driver	T1 X1	M
ff136:	Defrost: low gas temperature	Logico	985	X2	M
ff137:	Oil pressure	DI	985	DL1	A/M
ff138:	Low condensing pressure	Logico	985	X3	A
ff139:	Maximum saturated condensation temperature	Logico			A/M
ff140:	Minimum saturated condensation temperature	Logico			A/M
ff141:	Maximum saturated evaporation temperatur	Logico			A/M
ff142:	Minimum saturated evaporation temperatur	Logico			A/M
ff143:	Maximum compression ratio	Logico			A/M
FF144:	Minimum compression ratio	Logico			M
ff145:	Maximum engine torque	Logico			A/M
ii002:	Low water pressure	DI	687 central	T5 DU1	A/M
ii006:	Flow switch utility side	DI	687 central	T3 X8	A/M
II007:	Freeze alarm utility side				M
ii008:	Utility side pumps On for antifreeze alarm				A
II009:	COOL: outlet temperature higher than inlet temperature HEAT: inlet temperature higher than outlet temperature				A
ii120:	Flow switch source side	DI	985 circuit 1	T2 X4	A/M
II121:	Freeze alarm source side				A
II042:	FCI module, system pressure	DI	955 FCI	X3	M
II043:	FCI module, antifreeze alarm	Logico	955 FCI	X1	M
ii047:	FCI module, water flow alarm	DI	955 FCI	X4	A
ii052:	Recosery module, flow alarm	DI	965 REC	X6	A
ii053:	Recovery module, system pressure	DI	965 REC	X6	A

## 7.10 Display the status

Step	Display	Action	Menu/Variable	Keys		Notes
1		Press				
2	Main menu	Select	Machine State			
3		Select	General, circuit, ecc..			
4		Exit				

## 7.11 General stata and central module

code	description	detailed description
AI-687	T.IN H2OUtil_B1	Inlet water temperature utility side
AI-687	T.OUT H2OUtil_B2	Outlet water temperature user side
AI-687	Ext.Air temp_B3	Outdoor air temperature
AI-687	S.DemandLimit_X1	Signal of the demand limit function controls
AI-687	S.WaterReset_X2	Signal of the water reset function controls
AI-687	RHExt_X3	Outside relative humidity
AI-687	El.CabinetTemp_X4	Electrical panel temperature
AO-687	%FREE-COOLING_X5	Percentage value of the status of the external control signal of the ventilation/FREE-COOLING valve
DI-687	Sel.SetPoint_DU2	Status of the second digital input setpoint 0=1°set 1=2°Set
DI-687	SystemPressure_DU1	Status of the system water pressure sensor 0=OK 1=Fault
DI-687	FlowUser_X8	Status of the differential pressure switch/utilisation flow 0=OK 1=Fault
DI-687	ON-OFFRem_X7	Status of the unit status digital input 0=OFF 1=On
DI-687	Heat/CoolRem_X6	Status of the unit mode digital input 0=Heat 1=Cool
DI-687	PhaseMonitor_DL1	Status of the phase monitor input 0=OK 1=Fault
DI-687	OvIP1Util_D2	Status of thermal protection contact of utilisation pump 1 0=OK 1=Fault
DI-687	OvIP2Util_D1	Status of thermal protection contact of utilisation pump 2 0=OK 1=Fault
DI-687	OvIP3Util_DL2	Status of thermal protection contact of utilisation pump 3 0=OK 1=Fault
DO-687	El.CabinetFAN_DO1	Status of the ventilation control of the electrical panel: 0=Off 1=On
DO-687	El.CabinetHEAT_DO2	Status of the heating control of the electrical panel: 0=Off 1=On
DO-687	UnitMode_Q1	Status of the digital output related to the operating mode (N.O. Open=Cool N.O. Closed=Heat): 0=Cool 1=Heat
DO-687	Cumul.Alarm_Q2	Unit cumulative alarm status (N.O.Open=All OFF N.O. Closed=All ON): 0=Off 1=On
DO-687	CmdP1User_Q3	Command pump 1 utility side: 0=Off 1=On
DO-687	CmdP2User_Q4	Command pump 2 utility side: 0=Off 1=On
DO-687	CmdP3User_Q5	Command pump 3 utility side: 0=Off 1=On
DO-687	OpenYV_FC_Q7	Opening control of the FREE-COOLING valve FC Closed = ON: 0=Off 1=On
DO-687	CloseYV_FC_Q8	Closure control of the FREE-COOLING valve FC Closed = OFF: 0=Off 1=On
DO-687	AntifreezeHeater_Q6	Status of the control of the antifreeze heaters: 0=Off 1=On
S0001	StartsP1User	Number of startup totalized from Pump 1
S0002	StartsP2User	Number of startup totalized from Pump 2
S0003	StartsP3User	Number of startup totalized from Pump 3
S0004	Pump1 running hours	Utilisation pump 1 hours
S0005	Pump2 running hours	Utilisation pump 2 hours
S0006	Pump3 running hours	Utilisation pump 3 hours
S0007	Antifreeze heat.	Antifreeze heater status 0=Off 1=On
S0008	Pump in antifreeze	Status of the utilisation pump for antifreeze protection 0=Off 1=On
S0009	Recovery	Recovery status: 0=Off 1=On
S0010	ActualSptTExt	Setpoint value calculated by the Text climate curve
S0011	ActualSptWR	Setpoint value calculated by the WaterReset function
S0012	StatusFREE-COOLING	FREE-COOLING status 0=Off 1=On
S0013	GenWarning	0=Off 1=On
S0014	GenBlock	0=Off 1=On
S0015	NCompOnUnit	Number of compressors currently active on the machine

## 7.12 Circuit 1 status

code	description	detailed description
AI-94U	SuctionTemp_X2	Suction temperature
AI-94U	SuctionPressureX1	Low pressure transducer
AI-985	DischargeTC1_B1	Compressor 1 discharge temperature
AI-985	DischargeTC2_B2	Compressor 2 discharge temperature
AI-985	DischargeTC3_X2	Compressor 3 discharge temperature
AI-985	SourceTemp1_B3	Source 1 temperature (for machines with air-based sources and reversible on gas = Probe 1 on source battery. For machines with water-based source = Source input probe)
AI-985	SourceTemp2_X1	Source 2 temperature (for machines with air-based sources and reversible on gas = Probe 2 on source battery. For machines with water-based source = Source outlet probe)
AI-985	DischargePressure_X3	High pressure transducer
AO-985	%Cmd Cmp_X5	Percentage value of the status of the control signal of the modulating compressor
AO-985	%Cmd Source_X6	% value source modulating signal control
DI-985	Source WaterFlow_X4	Status of the source flow contact (Only active on machines with water-based source): 0=Fault 1=OK
DI-985	LP Pressure switch_X7	Status of the LP-pressure switch contact: 0=Fault 1=OK
DI-985	Ovl Inverter_DL1	Status of the inverter compressor heater contact: 0=Fault 1=OK
DI-985	HP Pressure switch_X8	Status of the HP-pressure switch contact: 0=Fault 1=OK
DI-985	Ovl Source_DL2	Status of the contact of the thermal protection of the source motors: 0=Fault 1=OK
DI-985	Ovl Cmp1_D1	Status of the contact of the thermal protection of compressor 1: 0=Fault 1=OK
DI-985	Ovl Cmp2_D2	Status of the contact of the thermal protection of compressor 2: 0=Fault 1=OK
DI-985	Ovl Cmp3_D3	Status of the contact of the thermal protection of compressor 3: 0=Fault 1=OK
DI-985	Diff.PressureOilScrew_D2	Status of the oil differential pressure switch contact (Active if compressor = Screw): 0=Fault 1=OK
DI-985	EnCircScrew_D3	Status of the circuit enabling input contact (Active if compressor = Screw): 0=Fault 1=OK
DO-985	Cmd Cmp1_Q2	Status of the compressor 1 control: 0=Off 1=On
DO-985	Cmd Cmp2_Q3	Status of the compressor 2 control: 0=Off 1=On
DO-985	Cmd Cmp3_Q4	Status of the compressor 3 control: 0=Off 1=On
DO-985	Cmd Source_Q1	Status of the source motor control: 0=Off 1=On
DO-985	Cmd Inj.Cmp1_Q5	Status of the compressor 1 liquid injection valve control: 0=Off 1=On
DO-985	Cmd Inj.Cmp2_Q7	Status of the compressor 2 liquid injection valve control: 0=Off 1=On
DO-985	Cmd Inj.Cmp3_Q8	Status of the compressor 3 liquid injection valve control: 0=Off 1=On
DO-985	Cmd YV4 reversing-Valve_Q6	Status of the cycle inversion valve control: 0=Off 1=On
DO-985	Cmd Digital_DO2	Status of the button valve control for compressors PWM: 0=Off 1=On
DO-985	Cmd KMLine_Q2	Status of the line counter control for the power supply Cmp (Active if compressor = Screw): 0=Off 1=On
DO-985	Cmd KMPW1_Q3	Status of the control of the motor's 1st winding (with PartWiding start-up) / Status of the star contactor control (with delta start-up)(Active if compressor = Screw): 0=Off 1=On
DO-985	Cmd KMPW2_Q4	Status of the control of the motor's 2nd winding (with PartWiding start-up) / Status of the control of the triangle contactor (with delta start-up)(Active if compressor = Screw): 0=Off 1=On
DO-985	Cmd YV25%_Q7	Status of the start e stop valve YV25%(Active if compressor = Screw): 0=Off 1=On
DO-985	Cmd YV75%_Q8	Status of the valve control of the YV75%(CR3_Bitzer) (14_Refcomp) (Active if compressor = Screw): 0=Off 1=On
DO-985	Cmd YVUP_DO1	Status of the power increase valve control (CR4_Bitzer) (16_RefComp) (Active if compressor = Screw): 0=Off 1=On
DO-985	Cmd YVDW_DO2	Status of the power decrease valve control (CR2_Bitzer) (15_RefComp) (Active if compressor = Screw): 0=Off 1=On
S1100	CMP1 starts	Number of startup totalized from Compressor 1
S1101	CMP2 starts	Number of startup totalized from Compressor 2
S1102	CMP3 starts	Number of startup totalized from Compressor 3
S1103	StartsScrew	Number of startup totalized from Compressor
S1104	Source starts	Number of startup totalized from source Fan or pump
S1105	Hours Comp.1	Compressor 1 hours
S1106	Hours Comp.2	Compressor 2 hours
S1107	Hours Comp.3	Compressor 3 hours
S1108	HoursScrew	Screw compressor hours
S1109	HoursSource	Screw compressor hours
S1110	Total steps	Total number of active steps on the circuit
S1111	Comp.1 status	Compressor 1: 0=free 1=on 2=timing 3=Disabled
S1112	Comp.2 status	Compressor 2: 0=free 1=on 2=timing 3=Disabled

code	description	detailed description
S1113	Comp.3 status	Compressor 3: 0=free 1=on 2=timing 3=Disabled
S1114	Current cap.	Capacity currently used up on the circuit
S1115	Requested cap.	Capacity required on the circuit
S1116	Pressure ratio	Compression ratio status (1+HP/1+LP)
S1117	FANPreAlarm	Status of the current maximum ventilation pre-alarm 0=Off 1=On
S1118	Defrost delay	Current value of the countdown towards the cycle inversion due to defrosting. (defrosting starts when the value reaches zero)
S1119	Defrosting status	Indicates the defrosting status 0=DfrOff (Cycle inversion phase for defrosting phase NOT active) 1=DfrON (Cycle inversion phase for defrosting phase ACTIVE)
S1120	HWErr	Hardware error of the POL94U module that does not preclude the possibility of moving the valve or closing it. Possible causes: anomalous voltage values in the valve motor 0=Off 1=On
S1121	BlckingHWErr	Hardware error of the POL94U module that prevents the electronic valve from moving. Possible causes: UPS not available, wrong POL94U Bios, HW POL94U Error, Disconnected EEV Motor, calibration error associated with configuration parameters. 0=Off 1=On
S1122	FailSafeSta	Active block status: 0=Off 1=On
S1123	UPSNotAval	UPS failure: 0=Off 1=On
S1124	CircWarning	Status associated with circuit block alarm
S1125	CircBlock	Lock alarm circuit
S1126	ThTDischarge	Theoretical discharge temperature

### 7.13 Thermostatic C1 status

code	description	detailed description
S1200	SHSpOp	Operating overheating setpoint net with SH and MET adjustments
S1201	AICalSuctSprHtP	Actual Overheating SetPoint
S1202	ECVState	0 = Idle 1 = ECValarm 2 = FailSafe 3 = Referencing 4 = Positioning 5 = Positioned 6 = ECVWaiting 7 = FastClosing
S1203	EEV:SH_Limiter	Maximum valve opening determined by the minimum SH control function
S1204	EEV:LET_Limiter	Status of the minimum LET intake temperature control
S1205	EEVMode	0=Idle (motor off) 1=Init (valve initialised when completely closed) 2=Manual (valve controlled in manual mode) 3=Control (the valve conducts adjustments to control SH)
S1206	Prepos	Thermostatic requested positioning %
S1207	ECVSetPos	% Opening valve if EEVMod = Manual
S1208	ECVMode	0 = Idle 1 = Init 2 = Position 3 = FastClose
S1209	SHPIDOut	% value of the PID output to adjust the valve
S1210	EEVStatus	0 - Closed (Ready) 1 - StartUpPositioning 2 - StartUpPositioned 3 - SuperHeat 4 - Prepositioning 5 - MET 6 - LET 7 - Closing 8 - PumpDown 9 - DangAlarm 10 - PumpDownStartUp 11 - ECValarm 12 - MinSHLmtr 13 - WaitValveClose 255 - Warning
S1211	SetPosSteps	Control of the number of steps the valve must reach to adjust overheating
S1212	SetPos%	Opening % control of the valve to adjust overheating
S1213	Pol94xCommOK	Connection status of the POL94U module on processbus: 0=NotOK 1=OK
S1214	ActPos%	% value of the actual position valve EEV
S1215	ActPosSteps	Current number of steps of the EEV valve
S1216	ECVMode	0 = Idle 1 = Init 2 = Position 3 = FastClose
S1217	ECVState	0 = Idle 1 = ECValarm 2 = FailSafe 3 = Referencing 4 = Positioning 5 = Positioned 6 = ECVWaiting 7 = FastClosing

### 7.14 Recovery circuit 1 status

code	description	detailed description
AI-965	P.OutRec_X7	Pressure value recovery circuit
AI-965	T.InH2ORec_X2	Recovery inlet water temperature
AI-965	T.OutH2ORec_X3	Recovery outlet water temperature
AI-965	T.OutGasRec_X1	Recovery gas outlet temperature (liquid)
AO-965	%CmdPmpRec_X8	% 0-10vcc signal value recovery variable pump
DI-965	EnableRec_X4	Enabling recovery input: 0=Fault 1=OK
DI-965	Ovl PmpRec_X5	Recovery thermal protection pump 0=Fault 1=OK
DI-965	FlowRec_X6	Flow recovery 0=Fault 1=OK
DI-965	SystemPress.Recovery_DL1	State of the water pressure switch contact of the system 0=Fault 1=OK

code	description	detailed description
DO-965	YV1Rec_DO1	Command valve YV1 0=Off 1=On
DO-965	YV2Rec_DO2	Command valve YV2 0=Off 1=On
DO-965	YV3Rec_Q1	Command valve YV3 0=Off 1=On
DO-965	YV4Rec_Q2	Command valve YV4 0=Off 1=On
DO-965	YV5Rec_Q3	Command valve YV5 0=Off 1=On
DO-965	PmpRec_Q4	Recovery pump command 0=Off 1=On

## 7.15 Master slave status

code	description	detailed description
S0600	SetPoint Unit1	Value accessible from the display of the unit machine network master. Working setpoint master unit (Address 1 on periferalbus)
S0601	SetPoint Unit2	Value accessible from the display of the unit machine network master. Working setpoint unit 2 (Address 2 on periferalbus)
S0602	SetPoint Unit3	Value accessible from the display of the unit machine network master. Working setpoint unit 3 (Address 3 on periferalbus)
S0603	SetPoint Unit4	Value accessible from the display of the unit machine network master. Working setpoint unit 4 (Address 4 on periferalbus)
S0604	SetPoint Unit5	Value accessible from the display of the unit machine network master. Working setpoint unit 5 (Address 5 on periferalbus)
S0605	SetPoint Unit6	Value accessible from the display of the unit machine network master. Working setpoint unit 6 (Address 6 on periferalbus)
S0606	SetPoint Unit7	Value accessible from the display of the unit machine network master. Working setpoint unit 7 (Address 7 on periferalbus)
S0607	statusUnit1	Value accessible from the display of the unit machine network master. Status master unit 7 0=Off 1=Eco 2=On 3=PmpOn
S0608	StatusUnit2	Value accessible from the display of the unit machine network master. Status unit 2 0=Off 1=Eco 2=On 3=PmpOn
S0609	StatusUnit3	Value accessible from the display of the unit machine network master. Status unit 3 0=Off 1=Eco 2=On 3=PmpOn
S0610	StatusUnit4	Value accessible from the display of the unit machine network master. Status unit 4 0=Off 1=Eco 2=On 3=PmpOn
S0611	StatusUnit5	Value accessible from the display of the unit machine network master. Status unit 5 0=Off 1=Eco 2=On 3=PmpOn
S0612	StatusUnit6	Value accessible from the display of the unit machine network master. Status unit 6 0=Off 1=Eco 2=On 3=PmpOn
S0613	StatusUnit7	Value accessible from the display of the unit machine network master. Status unit 7 0=Off 1=Eco 2=On 3=PmpOn

## 7.16 Hydronic module status

code	description	detailed description
AO-965	%CmdInverter_X7	% value inverter command signal
DI-965	OvIP1.Hid_X4	Pump 1 overload: 1=OK 1=Fault
DI-965	OvIP2.Hid_X5	Pump 2 overload: 0=OK 1=Fault
DI-965	OvIP3.Hid_X6	Pump 3 overload: 0=OK 1=Fault
DI-965	OvInv.Hid_DL1	Inverter overload: 0=OK 1=Fault
DO-965	CmdP1.Hid_DO1	Pump 1 command: 0=Off 1=On
DO-965	CmdP1Inv.Hid_Q2	Pump 1 inverter command: 0=Off 1=On
DO-965	CmdP2.Hid_DO2	Pump 2 command: 0=Off 1=On
DO-965	CmdP2Inv.Hid_Q3	Pump 2 inverter command: 0=Off 1=On
DO-965	CmdP3.Hid_Q1	Pump 3 command: 0=Off 1=On
DO-965	ComdP3Inv.Hid_Q4	Pump 3 inverter command: 0=Off 1=On
DO-965	CmdInverter:X8	Hydronic inverter command: 0=Off 1=On
S0500	StartsP1Hidro	Hydronic module pump 1 starts
S0501	StartsP2Hidro	Hydronic module pump 2 starts
S0502	StartsP3Hidro	Hydronic module pump 3 starts
S0503	HoursP1.Hid	Hydronic module pump 1 hours
S0504	HoursP32.Hid	Hydronic module pump 2 hours

code	description	detailed description
S0505	HoursP3.Hid	Hydronic module pump 3 hours
S0506	HoursInverter.Hid	Hydronic module inverter hours

## 7.17 Energy meter status

code	description	detailed description
S0720	U12	L1 - L2 voltage
S0721	U23	L2 - L3 voltage
S0722	U31	L3 - L1 voltage
S0723	Freq	Frequency
S0724	IL1	L1 current
S0725	IL2	L2 current
S0726	IL3	L3 current
S0727	Ptotale	Current active power
S0728	Cosfi	Total power factor
S0729	Energy	Active energy totalized
S0730	THD-U12	Sum of harmonic components of voltage between L1 e L2
S0731	THD-U23	Sum of harmonic components of voltage between L2 e L3
S0732	THD-U31	Sum of harmonic components of voltage between L3 e L1

## 8 Maintenance

### 8.1 General description

Maintenance must be done by authorized centres or by qualified personnel.

The maintenance allows to:

- maintain the unit efficiency
- increase the life span of the equipment
- assemble information and data to understand the state of the unit efficiency and avoid possible damages

Before checking, please verify the following:

- the electrical power supply line should be isolated at the beginning
- the unit isolator is open, locked and equipped with the suitable warning
- make sure no tension is present

 After turning off the power, wait at least 5 minutes before accessing to the electrical panel or any other electrical component.

 Before accessing check with a multimeter that there are no residual stresses.

### 8.2 Inspections frequency

Perform an inspection every 6 months minimum.

The frequency, however, depends on the use.

 In the event of frequent use it is recommended to plan inspections at shorter intervals:

- frequent use (continuous or very intermittent use, near the operating limits, etc)
- critical use (service necessary)

√	intervention frequency (months)	1	6	12
1	presence corrosion			X
2	panel fixing			X
3	fan fixing		X	
4	coil cleaning		X	
5	water filter cleaning		X	
6	check the exchanger efficiency			X
7	circulating pumps		X	
8	check of the fixing and the insulation of the power lead			X
9	check of the earthing cable			X
10	electric panel cleaning			X
11	capacity contactor status			X
12	termina closing, cable insulation integrity			X
13	voltage and phase unbalancing (no load and on-load)		X	
14	absorptions of the single electrical loads		X	
15	test of the compressor crankcase heaters		X	
16	leak control*			X
17	survey of the refrigerant circuit operating parameters		X	
18	protective device test: pressure switches, thermostats, flow switches etc..		X	
19	Safety valves: refer to the local regulations			
20	control system test: setpoint, climatic compensations, capacity stepping, water / air flow-rate variations		X	
21	control device test: alarm signalling, thermometers, probes, pressure gauges etc..		X	

\* European regulation 303/2008

Refer to the local regulations; and ensure correct adherence. Companies and technicians that effect interventions of installation, maintenance/repairs, leak control and recovery must be CERTIFIED as expected by the local regulations. The leak control must be effected with annual renewal.

### 8.3 Unit booklet

It's advisable to create a unit booklet to take notes of the unit interventions.

In this way it will be easier to adequately note the various interventions and aid any troubleshooting.

Report on the booklet:

- date
- type of intervention effected
- intervention description
- carried out measures etc.



## 8.4 Standby mode

If a long period of inactivity is foreseen:

- turn off the power
- avoid the risk of frost (empty the system or add glycol)

Turn off the power to avoid electrical risks or damages by lightning strikes.



With lower temperatures keep heaters turned on in of the electrical panel (option).

It's recommended that the re-start after the stopping period is performed by a qualified technician, especially after seasonal stops or seasonal switching.

When restarting, refer to what is indicated in the "start-up" section.

Schedule technical assistance in advance to avoid hitches and to guarantee that the system can be used when required.

## 8.5 Water side exchanger

It is very important for the exchanger to be able to provide the maximum thermal exchange, therefore it is essential for the inner surfaces to be clean of dirt and incrustations.

Periodically check the difference between the temperature of the supply water and the condensation temperature: if the difference is greater than 8°C–10°C it is advisable to clean the exchanger.

The clearing must be effected:

- with circulation opposite to the usual one
- with a speed at least 1,5 times higher than the nominal one
- with an appropriate product moderately acid (95% water + 5% phosphoric acid)
- after the cleaning rinse with water to inhibit the action of any residual product

## 8.6 Water filter

Check that no impurities prevent the correct passage of water.

## 8.7 Circulating pumps

Check:

- no leaks
- bearing status (anomalies are highlighted by abnormal noise and vibration)
- the terminal protection covers are closed and the cable holders are properly positioned

## 8.8 Flow Switch

- controls the operations
- remove incrustations from the palette

## 8.9 Electric fans

Check:

- the fans and the relative protection grids are well fixed
- the fan bearings (evident by noise and anomalous vibrations)
- the terminal protection covers are closed and the cable holders are properly positioned

## 8.10 Air coil



Contact with the exchanger fins can cause cuts: wear protective gloves to perform the above described operations.

It is extremely important that the battery gives the maximum thermal exchange; therefore, its surface must be cleaned from dust and deposits. Remove all impurities from the surface.

Using an air pressure gun, clean the aluminum surface of the battery; be careful to direct the air in the opposite direction of the fan air movement.

Hold the gun parallel to the fins to avoid damages.

As an alternative, vacuum cleaner can be used to suck impurities from the air input side.



Verify that the aluminum fins are not bent or damaged, in the event of damages contact the authorized assistance center and get the fins straightened in order to restore the initial condition for an optimal air flow.



### 8.11 Compressor supply line shut-off valve



A. Supply line shut-off valve



Do not remove the seal  
Remove only if authorized by the manufacturer.  
Please contact the maker for informations.

### 8.12 crankcase heater

Check:

- closure
- Operation

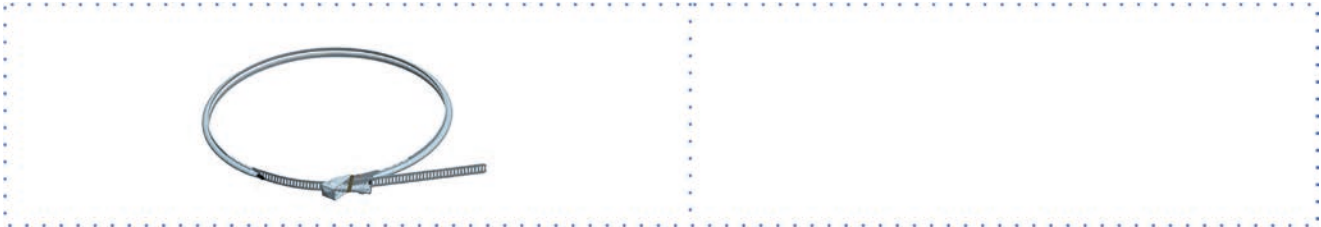

### 8.13 System discharge

1. evacuate the system
2. evacuate the exchanger, use all the present taps
3. use compressed air to blow the exchanger
4. dry completely the exchanger by an hot air jet; for greater safety fill the exchanger with glycoled solution
5. protect the exchanger from the air
6. remove the drain plugs to the pumps



Any anti-freeze liquid contained in the system should not be discharged freely as it is a pollutant.  
It must be collected and reused.  
Before starting a washing the plant.

Example

- emptying pump

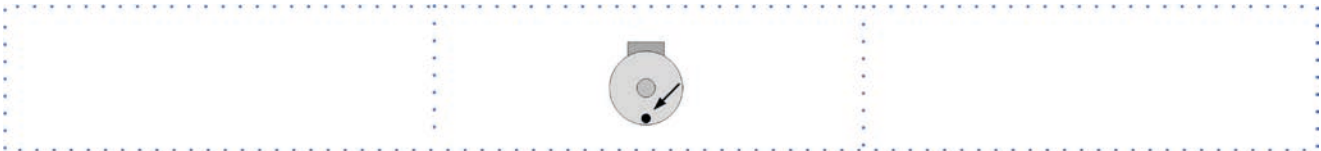

It's recommended that the re-start after the stopping period is performed by a qualified technician, especially after seasonal stops or seasonal switching.

When restarting, refer to what is indicated in the "start-up" section.

Schedule technical assistance in advance to avoid hitches and to guarantee that the system can be used when required.

## 9 Accessories

### 9.1 Antivibration



	W1	W2	W3	W4
PE2S00001	BBS100 60 sh	BBS100 60 sh	BBS100 60 sh	BBS100 60 sh
PE2S00002	BBS100 45 sh	BBS100 45 sh	BBS100 45 sh	BBS100 45 sh
PE2S00003	BBS100 45 sh	BBS100 60 sh	BBS100 45 sh	BBS100 60 sh
PE2S00004	BBS100 45 sh	BBS100 60 sh	BBS100 60 sh	BBS100 60 sh

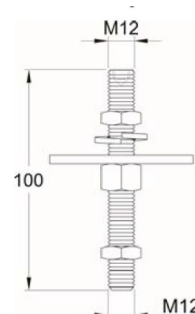
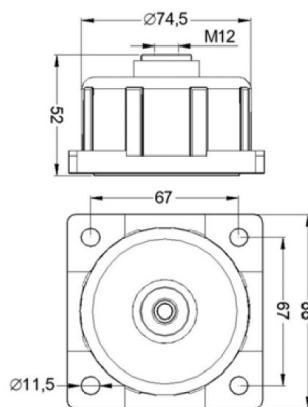
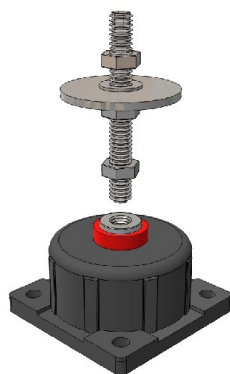
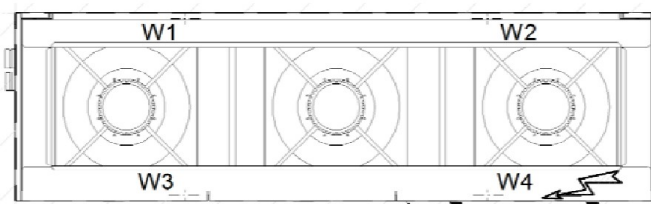
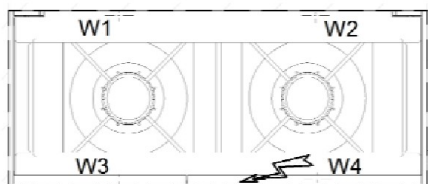

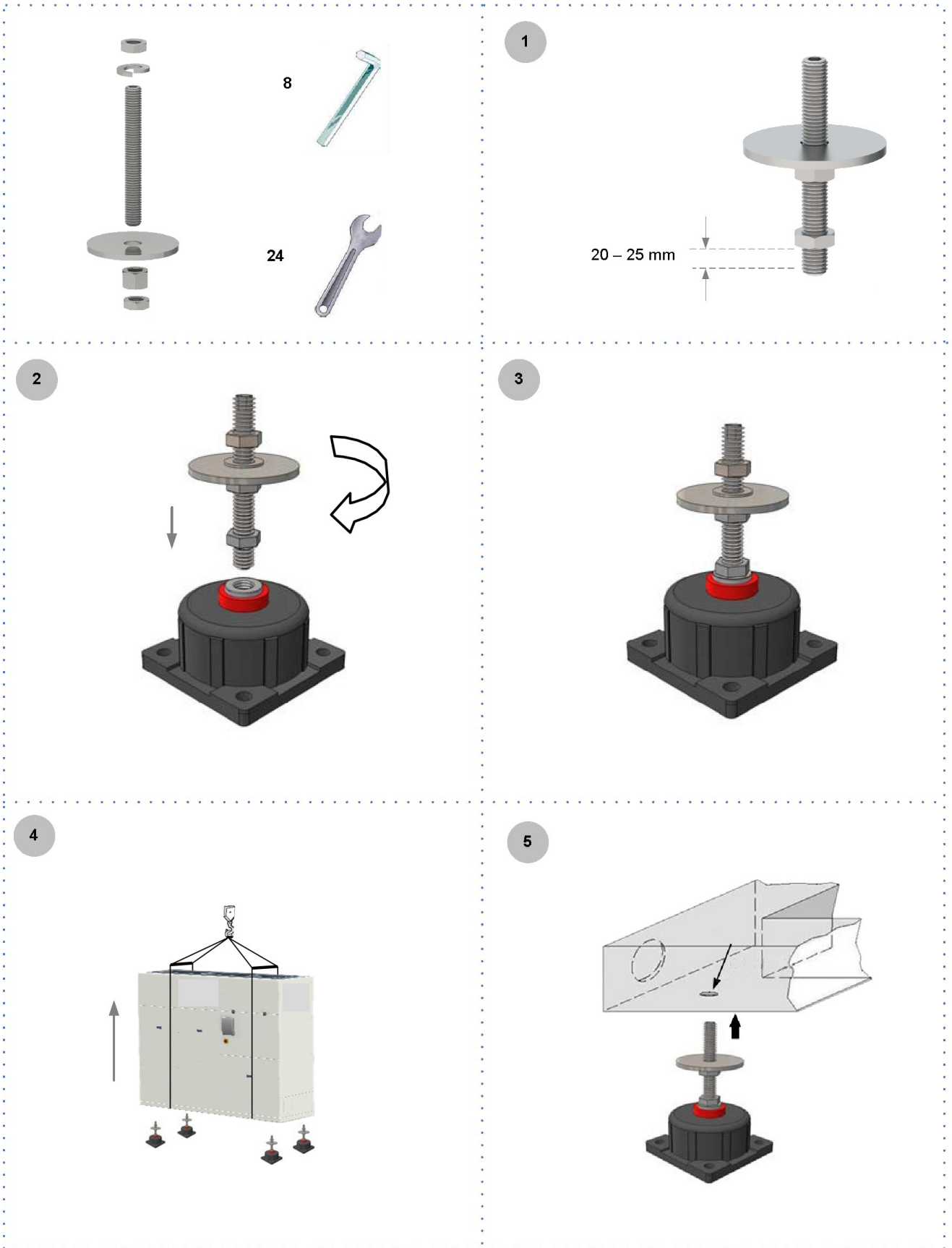

6

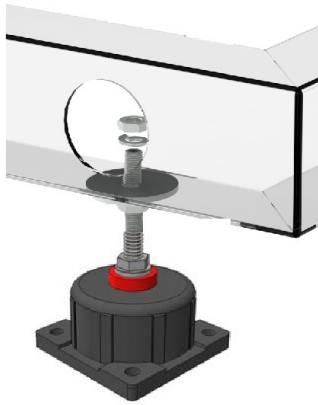

7

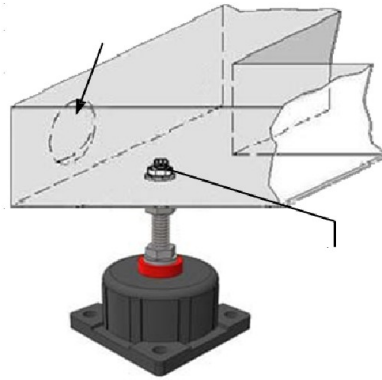

8

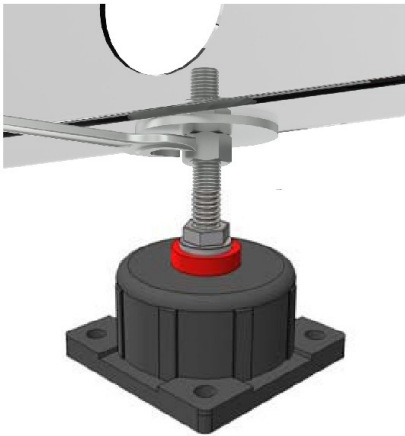

9

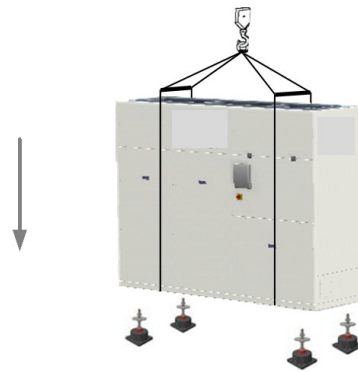

10



## 9.2 Fresh air probe

The external probe allows to automatically change the unit set point according to the external enthalpy (temperature + humidity).  
It is then possible to optimize the unit energy efficiency.

### **Positioning**

The sensor has not to be influenced by factors that can false the reading (for ex. direct solar irradiation, exhaust air by fan or other sources, contact with the unit structure or other sources of heat, accumulations of snow/ice), it has therefore to be placed in a protected place (possibly to the north), for example in an attic, under a terrace and if it is on a free wall, provide a small roofing.

## 10 Decommissioning

### 10.1 Disconnecting

Only authorised personnel must disconnect the unit.

Avoid leak or spills into the environment.

Before disconnecting the unit, the following must be recovered, if present:

- refrigerant gas
- anti-freeze solutions in the water circuit

Awaiting dismantling and disposal, the unit can also be stored outdoors, if the electrical, cooling and water circuits of the unit have 100% integrity and are isolated, bad weather and rapid change in temperature will not result in any environmental impact.

### 10.2 Dismantling and disposal

The unit must always be sent to authorised centres for dismantling and disposal.

When dismantling the unit, the fan, the motor and the coil, if operating, may be recovered by the specialist centres for reuse.

All the materials must be recovered or disposed of in compliance with the corresponding national standards in force.

For further information on the decommissioning of the unit, contact the manufacturer.

### 10.3 Directive EC RAEE

The units covered by the legislation in question are marked with the symbol on the side.

With the aim of protecting the environment, all of our units are produced in compliance with Directive EC on waste electrical and electronic equipment (RAEE).

The potential effects on the environment and on human health due to the presence of hazardous substances are shown in the use and maintenance manual in the section on residual risks.

Information in addition to that indicated below, if required, can be obtained from the manufacturer/distributor/importer, who are responsible for the collection/handling of waste originating from equipment covered by EC-RAEE. This information is also available from the retailer who sold this appliance or from the local authorities who handle waste.

Directive EC-RAEE requires disposal and recycling of electrical and electronic equipment as described therein to be handled through appropriate collection, in suitable centres, separate from collection for the disposal of mixed urban waste.

The user must not dispose of the unit at the end of its life cycle as urban waste, it must instead be handed over to appropriate collection centres as set forth by current standards or as instructed by the distributor.



## 11 Residual risks

### General description

In this section the most common situations are indicated, as these cannot be controlled by the manufacturer and could be a source of risk situations for people or things.

#### Danger zone

This is an area in which only an authorised operator may work. The danger zone is the area inside the unit which is accessible only with the deliberate removal of protections or parts thereof.

#### Handling

The handling operations, if implemented without all of the protection necessary and without due caution, may cause the drop or the tipping of the unit with the consequent damage, even serious, to persons, things or the unit itself.

Handle the unit following the instructions provided in the present manual regarding the packaging and in compliance with the local regulations in force.

Should the refrigerant leak please refer to the refrigerant "Safety sheet".

#### Installation

The incorrect installation of the unit could cause water leaks, condensate accumulation, leaking of the refrigerant, electric shock, poor operation or damage to the unit itself.

Check that the installation has been implemented by qualified technical personnel only and that the instructions contained in the present manual and the local regulations in force have been adhered to.

The installation of the unit in a place where even infrequent leaks of inflammable gas and the accumulation of this gas in the area surrounding the area occur could cause explosions or fires.

Carefully check the positioning of the unit.

The installation of the unit in a place unsuited to support its weight and/or guarantee adequate anchorage may result in consequent damage to things, people or the unit itself.

Carefully check the positioning and the anchoring of the unit.

Easy access to the unit by children, unauthorised persons or animals may be the source of accidents, some serious.

Install the unit in areas which are only accessible to authorised person and/or provide protection against intrusion into the danger zone.

#### General risks

Smell of burning, smoke or other signals of serious anomalies may indicate a situation which could cause damage to people, things or the unit itself.

Electrically isolate the unit (yellow-red isolator).

Contact the authorised service centre to identify and resolve the problem at the source of the anomaly.

Accidental contact with exchange batteries, compressors, air delivery tubes or other components may cause injuries and/or burns.

Always wear suitable clothing including protective gloves to work inside the danger zone.

Maintenance and repair operations carried out by non-qualified personnel may cause damage to persons, things or the unit itself. Always contact the qualified assistance centre.

Failing to close the unit panels or failure to check the correct tightening of all of the panelling fixing screws may cause damage to persons, things or the unit itself.

Periodically check that all of the panels are correctly closed and fixed.

If there is a fire the temperature of the refrigerant could reach values that increase the pressure to beyond the safety valve with the consequent possible projection of the refrigerant itself or explosion of the circuit parts that remain isolated by the closure of the tap.

Do not remain in the vicinity of the safety valve and never leave the refrigerating system taps closed.

#### Electric parts

An incomplete attachment line to the electric network or with incorrectly sized cables and/or unsuitable protective devices can cause electric shocks, intoxication, damage to the unit or fires.

Carry out all of the work on the electric system referring to the electric layout and the present manual ensuring the use of a system thereto dedicated.

An incorrect fixing of the electric components cover may lead to the entry of dust, water etc inside and may consequently electric shocks, damage to the unit or fires.

Always fix the unit cover properly.

When the metallic mass of the unit is under voltage and is not correctly connected to the earthing system it may be as source of electric shock and electrocution.

Always pay particular attention to the implementation of the earthing system connections.

Contact with parts under voltage accessible inside the unit after the removal of the guards can cause electric shocks, burns and electrocution.

Open and padlock the general isolator prior to removing the guards and signal work in progress with the appropriate sign.

Contact with parts that could be under voltage due to the start up of the unit may cause electric shocks, burns and electrocution.

When voltage is necessary for the circuit open the isolator on the attachment line of the unit itself, padlock it and display the appropriate warning sign.

#### Moving parts

Contact with the transmissions or with the fan aspiration can cause injuries.

Prior to entering the inside of the unit open the isolator situated on the connection line of the unit itself, padlock and display the appropriate warning sign.

Contact with the fans can cause injury.

Prior to removing the protective grill or the fans, open the isolator on the attachment line of the unit itself, padlock it and display the appropriate warning sign.

#### Refrigerant

The intervention of the safety valve and the consequent expulsion of the gas refrigerant may cause injuries and intoxication.

Always wear suitable clothing including protective gloves and eyeglasses for operations inside the danger zone.

Should the refrigerant leak please refer to the refrigerant "Safety sheet".

Contact between open flames or heat sources with the refrigerant or the heating of the gas circuit under pressure (e.g. during welding operations) may cause explosions or fires.

Do not place any heat source inside the danger zone.

The maintenance or repair interventions which include welding must be carried out with the system off.

#### Hydraulic parts

Defects in tubing, the attachments or the removal parts may cause a leak or water projection with the consequent damages to people, things or shortcircuit the unit.



# Standard unit

## General technical data

Size			182	222	262	302	352
<b>Cooling</b>							
Cooling capacity	1	kW	49.7	58.7	68.0	78.9	90.1
Compressor power input	1	kW	16.0	19.8	23.2	26.1	30.2
Partial recovery heating capacity	2	kW	16.4	19.6	22.8	26.2	30.1
Cooling capacity (EN14511:2013)	3	kW	49.3	58.3	67.5	78.6	89.8
Total power input (EN14511:2013)	3	kW	17.6	21.4	24.7	27.9	32.1
EER (EN 14511:2013)	3		2.81	2.72	2.74	2.81	2.79
SEER	9		3,81	3,80	3,82	3,81	3,80
<b>Compressor</b>							
Type of compressors	4		Scroll	Scroll	Scroll	Scroll	Scroll
No. of compressors		Nr	2	2	2	2	2
Rated power (C1)		HP	20	22	27	30	35
Std Capacity control steps		Nr	3	3	3	2	3
Oil charge (C1)		l	5.90	6.00	6.60	6.80	8.10
Refrigerant charge (C1)		kg	14	14	14	17	23
Refrigeration circuits		Nr	1	1	1	1	1
<b>Internal exchanger</b>							
Type of internal exchanger	5		PHE	PHE	PHE	PHE	PHE
Water flow-rate (User Side)	3	l/s	2,36	2,79	3,23	3,75	4,29
Internal exchanger pressure drops	3	kPa	45,5	47,0	49,6	24,1	25,6
Water content		l	4.00	4.70	5.40	6.40	7.00
<b>External Section Fans</b>							
Type of fans	6		RAD	RAD	RAD	RAD	RAD
Number of fans		Nr	2	2	3	3	3
Fan diameter		mm	500	500	500	500	500
Type of motor	7		EC	EC	EC	EC	EC
Standard airflow		l/s	5000	5000	6667	7500	7500
Installed unit power		kW	2.70	2.70	2.70	2.70	2.70
Max external static pressure		Pa	450	450	570	450	420
<b>Connections</b>							
Water fittings			1 1/2"	1 1/2"	1 1/2"	2"	2"
<b>Power supply</b>							
Standard power supply		V	400/3~/50	400/3~/50	400/3~/50	400/3~/50	400/3~/50
<b>Sound levels</b>							
Sound power in the duct	8	dB(A)	80	81	79	82	84

The Product is compliant with the Erp (Energy Related Products) European Directive. It includes the Commission delegated Regulation (EU) No 2016/2281, also known as Ecodesign Lot21. Contains fluorinated greenhouse gases' (GWP 2087,5)

1. Data refer to the following conditions: internal water exchanger = 12/7 °C; outdoor air temperature 35°C
2. Exchanger water temperature - Partial recovery = 40/45°C
3. Data calculated in compliance with Standard EN 14511:2011 referred to the following conditions : Internal exchanger water temperature = 12/7 °C, Input air temperature to the external exchanger = 35°C Static pressure of the ducted external section = 120 Pa
4. SCROLL = scroll compressor
5. PHE = plate exchanger
6. RAD = ventilatore radiale
7. EC Electronic switching motor
8. Sound power measured in accordance with UNI EN ISO 9614 and Eurovent 8/1 standards for ducted unit with available pressure equal to 120 Pa.
9. Data calculated according to the EN 14825:2016 Regulation

## Sound levels

Size	Sound power level (dB)								Sound power level	Sound pressure level
	Octave band (Hz)									
	63	125	250	500	1000	2000	4000	8000	dB(A)	dB(A)
182	73	77	80	78	73	69	65	54	62	79
222	73	77	80	78	73	70	65	54	62	79
262	71	76	79	77	73	70	65	56	61	79
302	73	78	80	78	74	70	65	55	63	80
352	77	82	85	82	78	76	70	58	66	84

Sound levels refer to units at full load.

The sound pressure is measured at 1 m from the external surface of the ducted unit operating in an open field. (standard UNI EN ISO 9614-2)

Data referred to the following conditions:

- Internal exchanger water temperature = 12/7°C
- outdoor air temperature 35°C
- Static available pressure 120 Pa

Please note that when the unit is installed in conditions different from nominal test conditions (e.g. near walls or obstacles in general), the sound levels may undergo substantial variations.

## Admissible water flow rates

Min. (Qmin) and max. (Qmax) water flow-rates admissibles for the correct unit operation

Size	182	222	262	302	352
Qmin [l/s]	1.3	1.5	1.7	2.9	3.2
Qmax [l/s]	3.6	4.2	4.7	8.1	9.0

## Exchanger operating range

TYPE OF TEST	Internal exchanger	
	DPr	DPw
	[kPa]	[kPa]
CLIVET C	4500	1000
PED (CE)	4500	1000

DPr = Max. operating pressure refrigerant gas side

DPw = Max. operating pressure water side (utility)

## Overload and control device calibrations

Setting instruments		apre	chiude	valore
High pressure safety pressure switch	[kPa]	4050	3300	-
Low pressure safety switch	[kPa]	450	600	-
low pressure switch (Brine)	[kPa]	200	350	-
antifreeze protection	[°C]	3	5.5	-
high pressure safety valve	[kPa]	-	-	4500
low pressure safety valve	[kPa]	-	-	3000
Max no. of compressor starts per hour	[n°]	-	-	10
high compressor discharge temperature safety thermostat	[°C]	-	-	120

# Operating range

Size			182	222	262	302	352
<b>External exchanger</b>							
Max entering air temperature	1	°C	45	45	45	45	45
Max entering air temperature	2	°C	48	48	48	48	48
Min. entering air temperature	3	°C	-10	-10	-10	-10	-10
Min. entering air temperature	4	°C	-7.0	-7.0	-7.0	-7.0	-7.0
<b>Internal exchanger</b>							
Max inlet water temperature		°C	27	27	27	27	24
Min. leaving water temperature	5	°C	5.0	5.0	5.0	5.0	5.0
Min. leaving water temperature	6	°C	-7.0	-7.0	-7.0	-7.0	-7.0

Data referred to the following conditions:  
 Internal exchanger water temperature = 12/7°C  
 Entering eExternal exchanger air temperature = 35°C

1. unit at full load

- 2. Unit with automatic staging of the compressor capacity.
- 3. unit at full load
- 4. Part-load unit
- 5. Standard unit and external exchanger entering air 35 °C (no 'Low water temperature (Brine)' configuration).
- 6. Unit in 'Low water temperature (Brine)' configuration. Fluid processed with 40% ethylene glycol

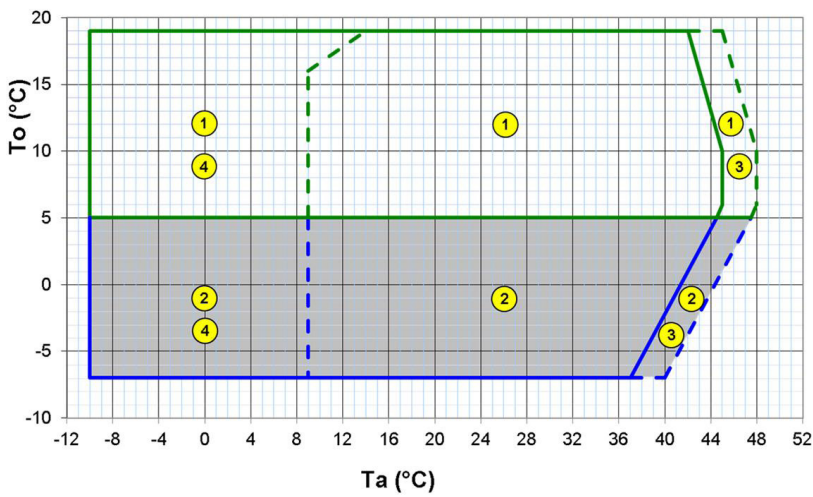

### Graph referred to size 352

The detail of each size is shown in tabular data.

Ta (°C) = entering external exchanger air temperature (dry bulb).  
 To (°C) = leaving internal exchanger water temperature

- 1. Standard unit; (no "Liquid low temperature" configuration)
- 2. Operation field extension for unit in 'Low water temperature (Brine)' configuration (40% ethylene glycol).
- 3. Unit with automatic staging of the compressor capacity.
- 4. Unit at full-load with air flow automatic modulation

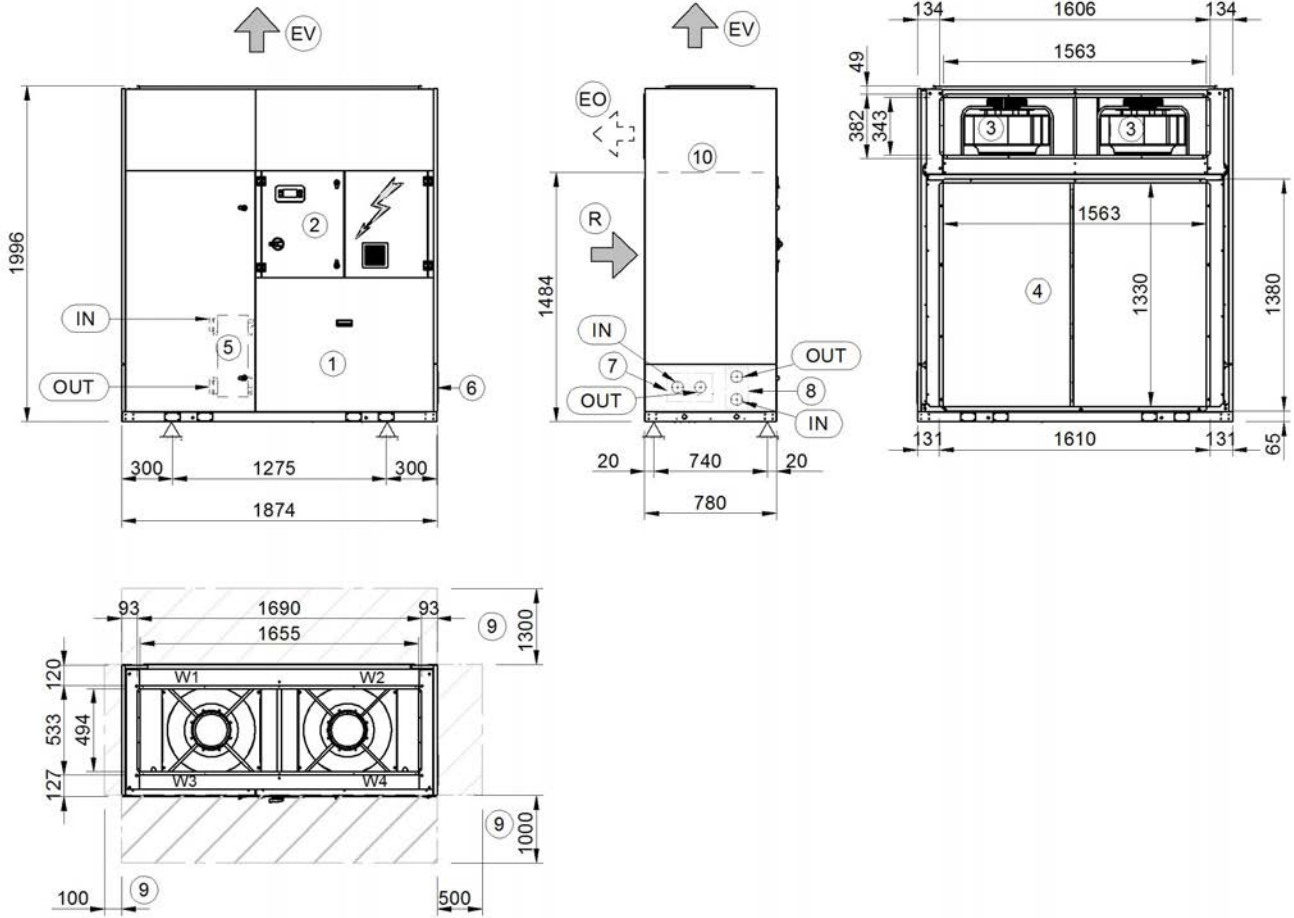

- (1) Compressor compartment
- (2) General electrical panel
- (3) Exhaust radial electric fans
- (4) External exchanger
- (5) Internal exchanger
- (6) Electric line input
- (7) Hydraulic fittings flush with unit (optional)
- (8) Partial recovery water fittings (optional)
- (9) Functional clearances
- (10) Separation line
- (R) Outdoor air return
- (EV) Vertical air exhaust (standard)
- (EO) Horizontal air exhaust (optional)

Size			182	222
A - Length		mm	1874	1874
B - Width		mm	780	780
C - Height		mm	1996	1996
W1 Supporting Point		kg	98	98
W2 Supporting Point		kg	169	171
W3 Supporting Point		kg	117	118
W4 Supporting Point		kg	188	191
Shipping weight		kg	565	572
Operating weight		kg	572	578

La presenza di accessori opzionali può comportare una variazione significativa dei pesi indicati in tabella.

## Sizes 262-302-352

DAB2S262\_402\_0 REV00  
DATA 23/06/2016

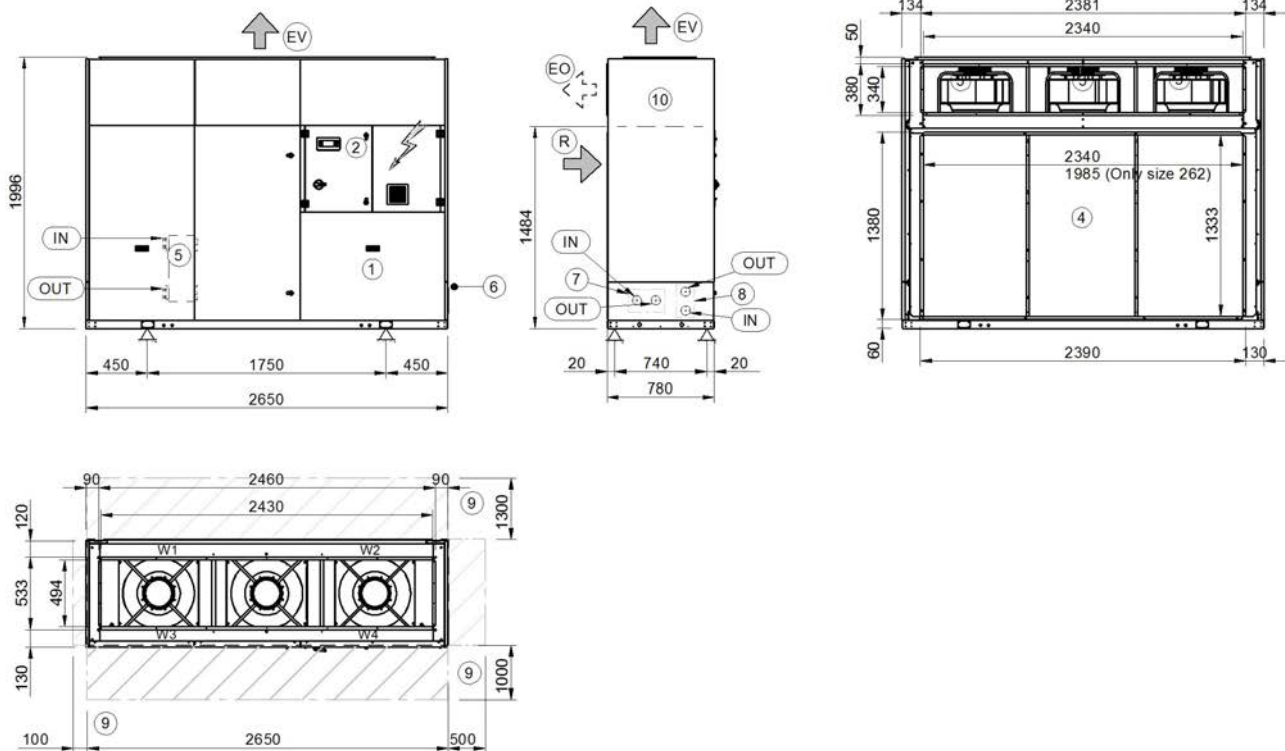

- |   |  |
|---|--|
| (1) Compressor compartment                        | (9) Functional clearances              |
| (2) General electrical panel                      | (10) Separation line                   |
| (3) Exhaust radial electric fans                  | (R) Outdoor air return                 |
| (4) External exchanger                            | (EV) Vertical air exhaust (standard)   |
| (5) Internal exchanger                            | (EO) Horizontal air exhaust (optional) |
| (6) Electric line input                           |  |
| (7) Hydraulic fittings flush with unit (optional) |  |
| (8) Partial recovery water fittings (optional)    |  |

Size			262	302	352
A - Length		mm	2650	2650	2650
B - Width		mm	780	780	780
C - Height		mm	1996	1996	1996
W1 Supporting Point		kg	128	138	150
W2 Supporting Point		kg	192	202	242
W3 Supporting Point		kg	146	154	164
W4 Supporting Point		kg	210	217	255
Shipping weight		kg	667	704	804
Operating weight		kg	676	711	810

La presenza di accessori opzionali può comportare una variazione significativa dei pesi indicati in tabella.

Page intentionally left blank



**CLIVET**®

---

**CLIVET SPA**

Via Camp Lonc 25, Z.I. Villapaiera - 32032 Feltre (BL) - Italy  
Tel. + 39 0439 3131 - Fax + 39 0439 313300 - info@clivet.it

**CLIVET GROUP UK Limited**

4 Kingdom Close, Segensworth East - Fareham, Hampshire - PO15 5TJ - United Kingdom  
Tel. + 44 (0) 1489 572238 - Fax + 44 (0) 1489 573033 - enquiries@clivetgroup.co.uk

**CLIVET GROUP UK Limited (Operations)**

Units F5&F6 Railway Triangle Ind Est, Walton Road - Portsmouth, Hampshire - PO6 1TG - United Kingdom  
Tel. +44 (0) 2392 381235 - Fax. +44 (0) 2392 381243 - service@clivetgroup.co.uk

**CLIVET ESPAÑA S.A.U.**

C/ Bac de Roda, 36 - 08019 Barcelona - España  
Tel: +34 93 8606248 - Fax +34 93 8855392 - info@clivet.es

Av.Manoteras Nº 38, Oficina C303 - 28050 Madrid - España  
Tel. +34 91 6658280 - Fax +34 91 6657806 - info@clivet.es

**CLIVET GmbH**

Hummelsbütteler Steindamm 84, 22851 Norderstedt - Germany  
Tel. + 49 (0) 40 32 59 57-0 - Fax + 49 (0) 40 32 59 57-194 - info.de@clivet.com

**CLIVET RUSSIA**

Elektrozavodskaya st. 24, office 509 - 107023, Moscow, Russia  
Tel. + 74956462009 - Fax + 74956462009 - info.ru@clivet.com

**CLIVET MIDEAST FZCO**

Dubai Silicon Oasis (DSO), High Bay Complex, Office N. 20, PO BOX 342009, Dubai, UAE  
Tel. + 9714 3208499 - Fax + 9714 3208216 - info@clivet.ae

**CLIVET AIRCONDITIONING SYSTEMS PRIVATE LIMITED**

4BA, Gundecha Onclave, Kherani Road - Sakinaka, Andheri (East) - Mumbai 400 072 - India  
Tel. +91 22 6193 7000 - Fax +91 22 6193 7001 - info.in@clivet.com

---

[www.clivet.com](http://www.clivet.com)  
[www.clivetlive.com](http://www.clivetlive.com)

A Group Company of

