

# WSHN-XEE2 10.2 - 120.2

Water cooled heat pump for indoors installation



Dear Customer,

We congratulate you on choosing this product

For many years Clivet has been offering systems that provide maximum comfort, together with high reliability, efficiency, quality and safety.

The aim of the company is to offer advanced systems, that assure the best comfort, reduce energy consumption and the installation and maintenance cost for the life cycle of the system.

The purpose of this manual is to provide you with information that is useful from reception of the equipment, through installation, operational usage and finally disposal so that this advanced system offers the best solution.

Yours faithfully,

CLIVET Spa

The data contained in this manual is not binding and may be changed by the manufacturer without prior notice.

Reproduction, even in part, is FORBIDDEN © Copyright - CLIVET S.p.A. - Feltre (BL) - Italia

---

# Index of contents

1	General description	4
2	Reception	6
3	Positioning	9
4	Water connections	10
5	Electrical connections	13
6	Start-up	19
7	Control	27
8	Maintenance	37
9	Accessories	41
10	Decommissioning	47
11	Residual risks	48
12	Technical information	49
13	Dimensional drawings	56

# 1 General description

## 1.1 Manual

The manual provides correct unit installation, use and maintenance.

Pay particular attention to:



Warning, identifies particularly important operations or information.



Prohibited operations that must not be carried out, that compromise the operating of the unit or may cause damage to persons or things.

- It is advisable to read it carefully so you will save time during operations.
- Follow the written indications so you will not cause damages to things and injuries people.

## 1.2 Preliminaries

Only qualified personnel can operate on the unit, as required by the regulation in force.

## 1.3 Risk situations



The unit has been designed and created to prevent injuries to people.

During designing it is not possible to plan and operate on all risk situation.

Read carefully "Residual risk" section where all situation which may cause damages to things and injuries to people are reported.

Installation, starting, maintenance and repair required specific knowledge; if they are carried out by inexperienced personnel, they may cause damages to things and injuries people.

## 1.4 Intended use

Use the unit only:

- for cooling/heating water or a water and glycol mix
- keep to the limits foreseen in the technical schedule and in this manual

The manufacturer accepts no responsibility if the equipment is used for any purpose other than the intended use.

## 1.5 Installation

Outdoor installation



The positioning, hydraulic system, refrigerating, electrics and the ducting of the air must be determined by the system designer in accordance with local regulations in force.

Follow local safety regulations.

Verify that the electrical line characteristics are in compliance with data quotes on the unit serial number label.

## 1.6 Maintenance

Plan periodic inspection and maintenance in order to avoid or reduce repairing costs.



Turn the unit off before any operation.

## 1.7 Modification



All unit modifications will end the warranty coverage and the manufacturer responsibility.

## 1.8 Breakdown/Malfunction

Disable the unit immediately in case of breakdown or malfunction.

Contact a certified service agent.

Use original spares parts only.

Using the unit in case of breakdown or malfunction:

- voids the warranty
- it may compromise the safety of the unit
- may increase time and repair costs

## 1.9 User training



The installer has to train the user on:

- Start-up/shutdown
- Set points change
- Standby mode
- Maintenance
- What to do / what not to do in case of breakdown

## 1.10 Data update

Continual product improvements may imply manual data changes.

Visit manufacturer web site for updated data.

## 1.11 Indications for the User



Keep this manual with the wiring diagram in an accessible place for the operator.

Note the unit data label so you can provide them to the assistance centre in case of intervention (see “Unit identification” section).

Provide a unit notebook that allows any interventions carried out on the unit to be noted and tracked making it easier to suitably note the various interventions and aids the search for any breakdowns.

In case of breakdown or malfunction:

- Immediately deactivate the unit
- Contact a service centre authorized by the manufacturer



The installer must train the user, particularly on:

- Start-up/shutdown
- Set points change
- Standby mode
- Maintenance
- What to do / what not to do in case of breakdown

## 1.12 Unit identification

The serial number label is positioned on the unit and allows to identify all the unit features.

The matriculation plate shows the indications foreseen by the standards, in particular:

- unit type
- serial number (12 characters)
- year of manufacture
- wiring diagram number
- electrical data
- type of refrigerant
- refrigerant charge
- manufacturer logo and address



The matriculation plate must never be removed.



It contains fluorinated greenhouse gases

Type of refrigerant: R410A

## 1.13 Serial number

It identifies uniquely each unit.

Must be quoted when ordering spare parts.

## 1.14 Assistance request

Note data from the serial number label and write them in the chart on side, so you will find them easily when needed.

Series
Size
Serial number
Year of manufacture
Electrical wiring diagram

## 2 Reception

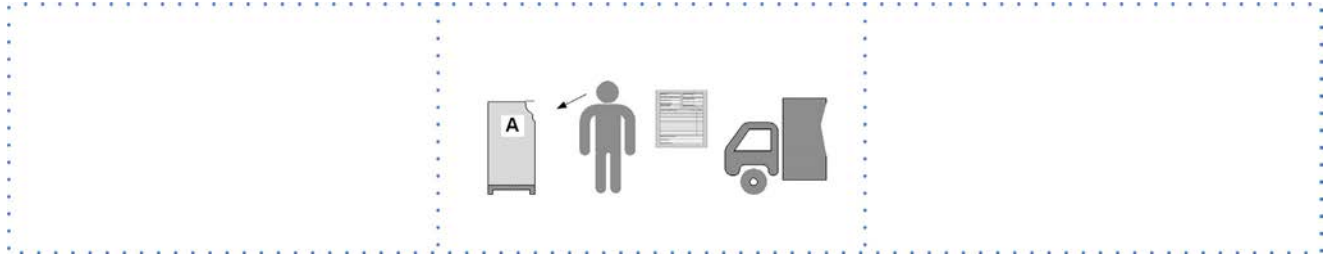

You have to check before accepting the delivery:

- That the unit hasn't been damaged during transport
- That the materials delivered correspond with that indicated on the transport document comparing the data with the identification label positioned on the packaging.

In case of damage or anomaly:

- Write down on the transport document the damage you found and quote this sentence: "Conditional acceptance clear evidence of deficiencies/damages during transport"
- Contact by fax and registered mail with advice of receipt to supplier and the carrier.



Any disputes must be made within 8 days from the date of the delivery. Complaints after this period are invalid.

### 2.1 Storage

Observe external packaging instructions.

### 2.2 Handling

1. Verify unit weight and handling equipment lifting capacity.
2. Identify critical points during handling (disconnected routes, flights, steps, doors).
3. Suitably protect the unit to prevent damage.
4. Lifting with balance
5. Lifting with spacer bar
6. Align the barycenter to the lifting point
7. Gradually bring the lifting belts under tension, making sure they are positioned correctly.
8. Before starting the handling, make sure that the unit is stable.

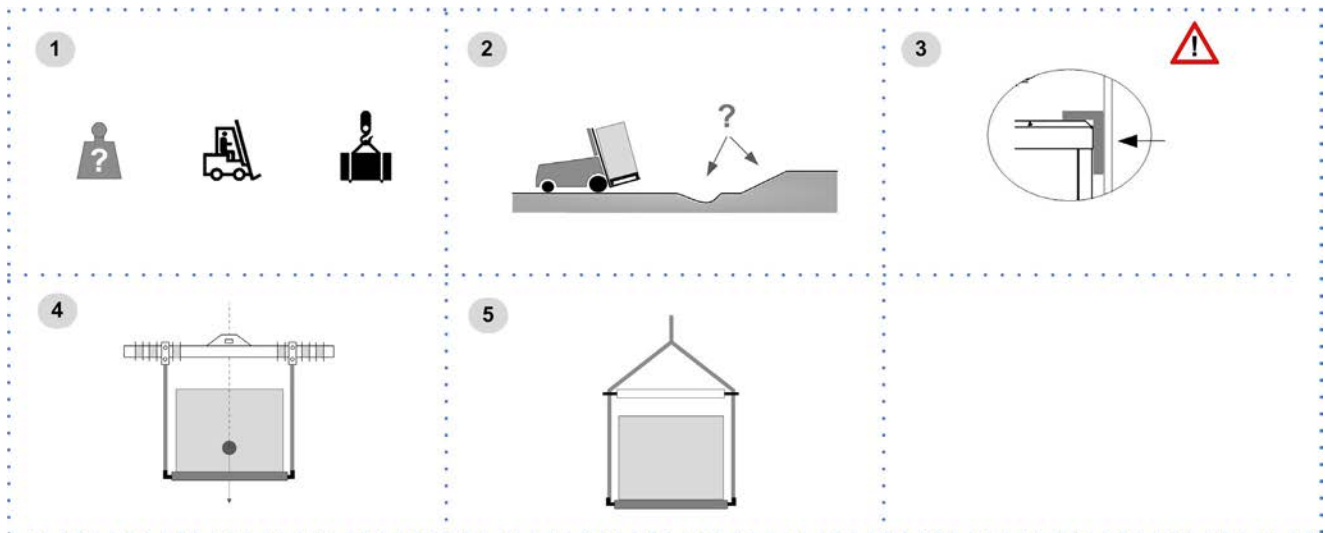

## 2.3 Instructions for disassembly

Only with options: MOB/MAG

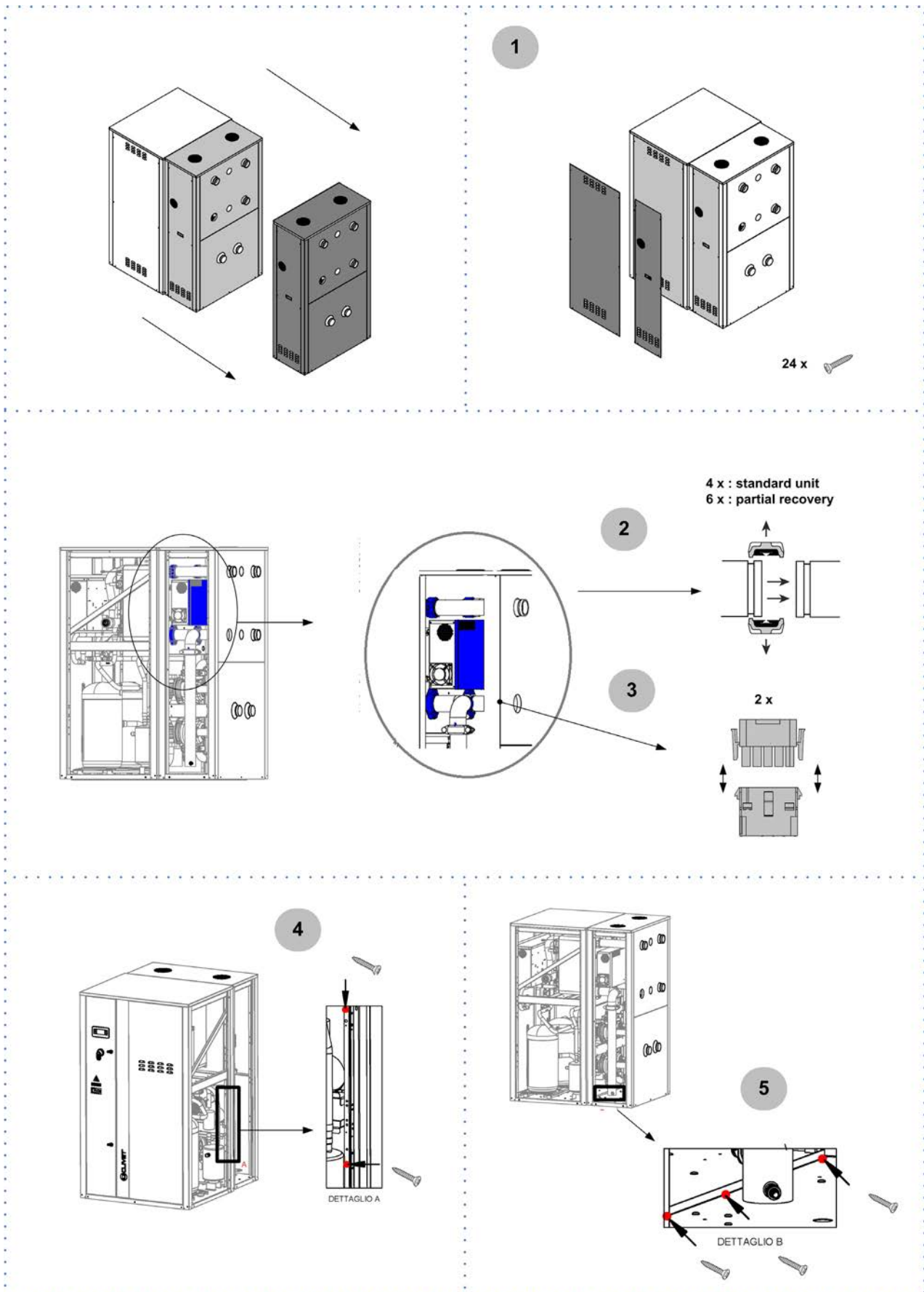

Isolating switch

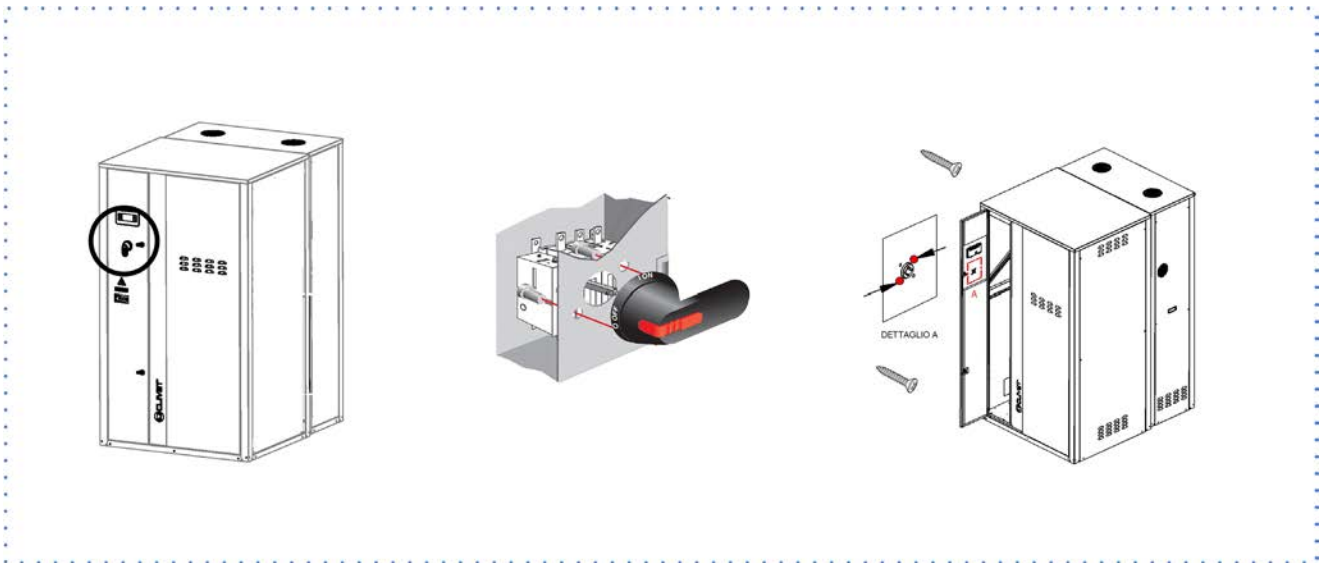

## 2.4 Packaging removing

Be careful not to damage the unit.

Cut-off valves installed at inlet and outlet (both on the water technique circuit as well as that of the hot domestic water) allow maintenance operations without having to empty the system.

Recycle and dispose of the packaging material in conformity with local regulations.

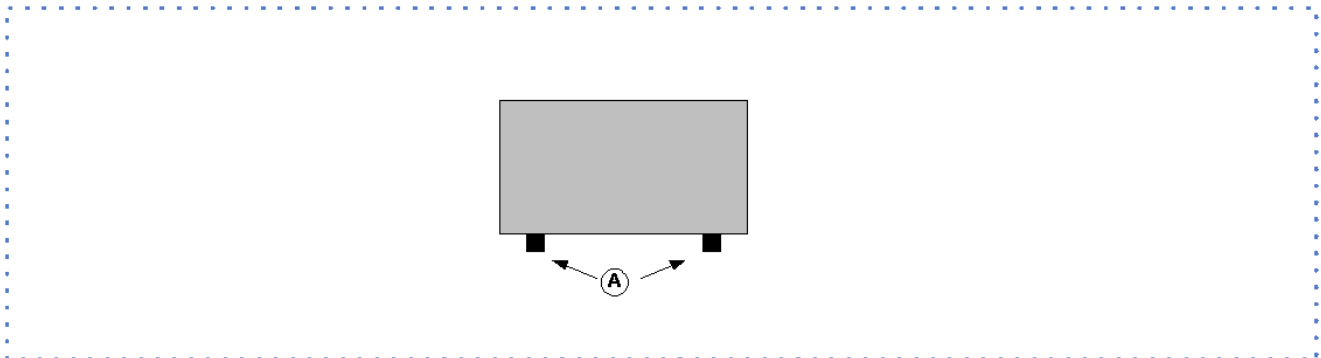

A Supports for handling: remove after the handling.



## 3 Positioning

During positioning consider these elements:

- Technical spaces requested by the unit
- Electrical connections
- Water connections
- Spaces for air exhaust and intake

### 3.1 Functional spaces

Functional spaces are designed to:

- guarantee good unit operation
- carry out maintenance operations
- protect authorized operators and exposed people

Respect all functional spaces indicated in the DIMENSIONS section.

Double all functional spaces if two or more unit are aligned.

### 3.2 Positioning



Units are designed to be installed:

- INTERNAL
- in fixed positions

Limit vibration transmission:

- use antivibration devices on unit bearing points
- install flexible joints on the hydraulic connections

Choose the installation place according to the following criteria:

- Customer approval
- safe accessible position
- technical spaces requested by the unit
- max. distance allowed by the electrical connections
- Avoid installations in places subject to flooding
- verify unit weight and bearing point capacity
- verify that all bearing points are aligned and leveled

### 3.3 Safety valve gas side

The installer is responsible for evaluating the opportunity of installing drain tubes, in conformity with the local regulations in force (EN 378).

## 4 Water connections

### 4.1 Water quality

Water features

- conforming to local regulations
- total hardness < 14°fr
- within the limits indicated by table

The water quality must be checked by qualified personnel.

Water with inadequate characteristics can cause:

- pressure drop increase
- reduces energy efficiency
- increased corrosion potential

Acceptable water quality values:

PH	7,5 ÷ 9,0	
SO <sub>4</sub> <sup>2-</sup>	< 100	ppm
HCO <sub>3</sub> <sup>-</sup> /SO <sub>4</sub> <sup>2-</sup>	> 1	
Total Hardness	4,5 ÷ 8,5	dH
Cl <sup>-</sup>	< 50	ppm
PO <sub>4</sub> <sup>3-</sup>	< 2,0	ppm
NH <sub>3</sub>	< 0,5	ppm

Free Chlorine	< 0,5	ppm
Fe <sub>3</sub> <sup>+</sup>	< 0,5	ppm
Mn <sup>++</sup>	< 0,05	ppm
CO <sub>2</sub>	< 50	ppm
H <sub>2</sub> S	< 50	ppb
Temperature	< 65	°C
Oxygen content	< 0,1	ppm

Provide a water treatment system if values fall outside the limits.



The warranty does not cover damages caused by limestone formations, deposits and impurities from the water supply and / or failure from failed system clearing to clean system.

### 4.2 Risk of freezing

If the unit or the relative water connections are subject to temperatures close to 0°C:

- mix water with glycol, or
- safeguard the pipes with heating cables placed under the insulation, or
- empty the system in cases of long non-use

### 4.3 Anti-freeze solution

The use of an anti-freeze solution results in an increase in pressure drop.



Make sure that the glycol type utilized is inhibited (not corrosive) and compatible with the water circuit components.



Do not use different glycol mixture (i.e. ethylene with propylene).

### 4.4 Water flow rate

The project water-flow rate must be:

- inside the exchanger operating limits (see the TECHNICAL INFORMATION section)
- guaranteed, also with variable system conditions (for example in systems where some circuits are bypassed in particular situations).

### 4.5 Hydraulic connections

- take away the supplied connection union by acting on the connection joint
- weld the union to the installation pipe
- perform the connection between the installation pipe and the evaporator, using the joint



Do not weld the system pipe with the Victaulic connection joint attached.



The rubber gasket might be irreparably damaged.

## 4.6 Recommended connection

- ⚠ The installer must define
- component type
  - position in system

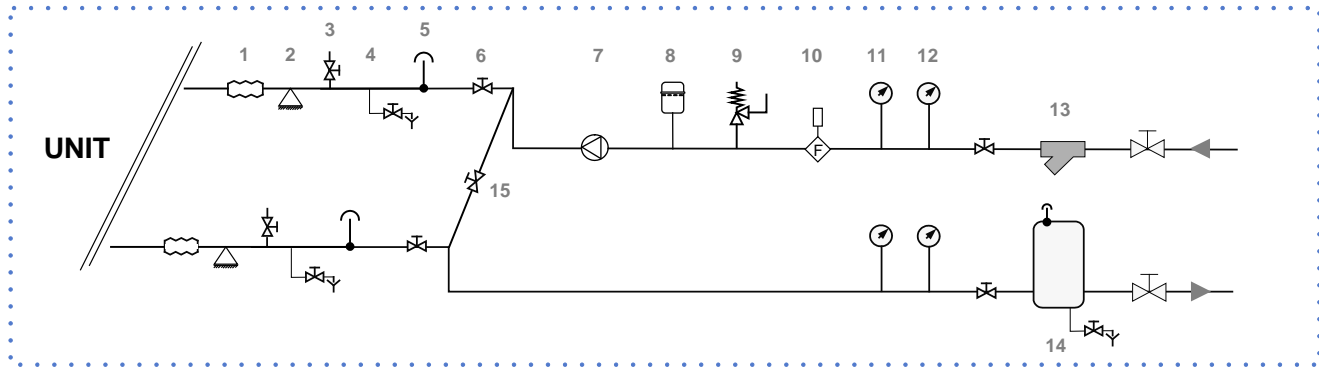

- |   |                                    |    |                        |
|---|------------------------------------|----|------------------------|
| 1 | antivibration joints               | 9  | safety valve           |
| 2 | piping support                     | 10 | Flow Switch            |
| 3 | exchanger chemical cleaning bypass | 11 | pressure gauge         |
| 4 | drain valve                        | 12 | thermometer            |
| 5 | vent                               | 13 | filter                 |
| 6 | shut-off valve                     | 14 | Internal storage tank  |
| 7 | Pump / circulating pump            | 15 | Cleaning system bypass |
| 8 | expansion vessel                   |    |                        |

## 4.7 Water filter

Use filter with mesh pitch:

Size	Mesh pitch
10.2 - 22.2	0,5 mm
27.2 - 90.2	1,5 mm
100.2 - 120.2	1,6 mm

- ⚠ It must be installed immediately in the water input of the unit, in a position that is easily accessible for cleaning.
- ⊘ The filter never should be removed, this operation invalidates the warranty.

## 4.8 Flow Switch

- ⚠ The flow switch must be present to ensure shutdown of the unit if water is not circulating. It has to be installed in a duct rectilinear part, not in proximity of curves that cause turbulences.

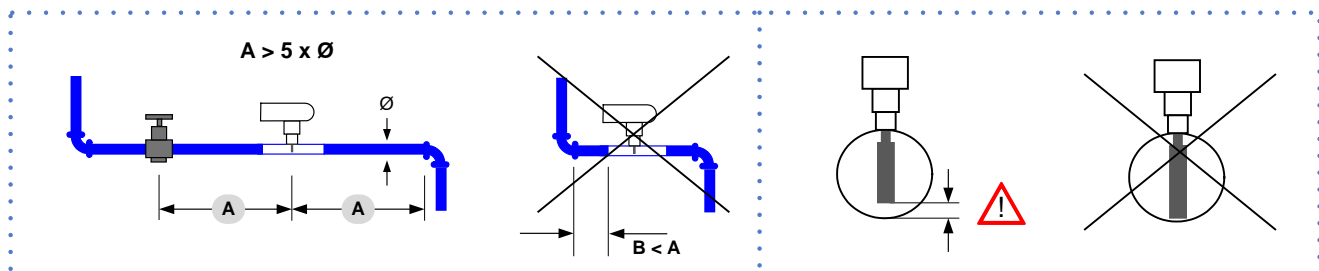

A. minimum distance

## 4.9 Operation sequence

Close all vent valves in the high points of the unit hydraulic circuit

Close all drain valves in the low points of the unit hydraulic circuit:

- Heat exchangers
  - Pumps
  - collectors
  - storage tank
  - free-cooling coil
1. Carefully wash the system with clean water: fill and drain the system several times.
  2. Apply additives to prevent corrosion, fouling, formation of mud and algae.
  3. Fill the plant
  4. Execute leakage test.
  5. Isolate the pipes to avoid heat dispersions and formation of condensate.
  6. Leave various point of service free (wells, vent-holes etc).



Neglecting the washing will lead to several filter cleaning interventions and at worst cases can cause damages to the exchangers and the other parts.

## 4.10 hydronic assembly

For details see:

9 Accessories p. 41

## 4.11 VALVE FOR DOMESTIC HOT WATER

For details see:

9 Accessories p. 41

## 4.12 NATURAL COOLING function

For details see:

9.6 NATURAL COOLING function p. 46

## 5 Electrical connections

The characteristics of the electrical lines must be determined by qualified electrical personnel able to design electrical installations; moreover, the lines must be in conformity with regulations in force.

The protection devices of the unit power line must be able to stop all short circuit current, the value must be determined in accordance with system features.

The power cables and the protection cable section must be defined in accordance with the characteristics of the protections adopted.

All electrical operations should be performed by trained personnel having the necessary qualifications required by the regulations in force and being informed about the risks relevant to these activities.

Operate in compliance with safety regulations in force.

### 5.1 Electrical data



The serial number label reports the unit specific electrical data, included any electrical accessories.

The electrical data indicated in the technical bulletin and in the manual refer to the standard unit, accessories excluded.

The matriculation plate shows the indications foreseen by the standards, in particular:

- Voltage
- F.L.A.: full load ampere, absorbed current at maximum admitted conditions
- F.L.I.: full load input, full load power input at max. admissible condition
- Electrical wiring diagram Nr.

### 5.2 Connections

1. Refer to the unit electrical diagram (the number of the diagram is shown on the serial number label).
2. Verify that the electrical supply has characteristics conforming to the data shown on the serial number label.
3. Before starting work, ensure the unit is isolated, unable to be turned on and a safety sign used.
4. Ensure correct earth connection.
5. Ensure cables are suitably protected.
6. Before powering up the unit, make sure that all the protections that were removed during the electrical connection work have been restored.

### 5.3 Signals / data lines

Do not exceed the maximum power allowed, which varies, according to the type of signal.

Lay the cables far from power cables or cables having a different tension and that are able to emit electromagnetic disturbances.

Do not lay the cable near devices which can generate electromagnetic interferences.

Do not lay the cables parallel to other cables, cable crossings are possible, only if laid at 90°.

Connect the screen to the ground, only if there aren't disturbances.

Guarantee the continuity of the screen during the entire extension of the cable.

Respect impedance, capacity and attenuation indications.

### 5.4 Power input



Fix the cables: if vacated may be subject to tearing.



The cable must not touch the compressor and the refrigerant piping (they reach high temperatures).

## 5.5 Connections performed by customer

	English	Deutsch	Español	Italiano	Français
DEMAND LIMIT	demand limit	demand limit	demand limit	demand limit	demand limit
WATER RESET	water reset	water reset	water reset	water reset	water reset
BTair-Ext	outside air temperature probe	Außenlufttemperaturfühler	sonda de temperatura aire externo	sonda di temperatura aria esterna	sonde de température air extérieur
YVNC	natural-cooling 3-way valve	3-Wegeventil Natural-Cooling	válvula de 3 vías natural-cooling	valvola 3 vie natural-cooling	soupape 3-voies natural-cooling
YVNCM	natural-cooling 3-way valve	3-Wegeventil Natural-Cooling	válvula de 3 vías natural-cooling	valvola 3 vie natural-cooling	soupape 3-voies natural-cooling
SA5	remote winter/summer selector	Fernwahlschalter Winter/Sommer	selector remoto "verano/invierno"	selettore remoto estate/inverno	sélecteur déporté "été/hiver"
SA1	remote on/off selector	Fernwahlschalter Ein/Aus	selector on/off remoto	selettore on/off remoto	sélecteur ON/OFF déporté
SQS	Source side exchanger flow switch	Stromungswächter des Nennleistungszweiges	Fujistato combiador lado fuente	flussstato scambiatore lato sorgente	Contrôleur de débit de l'échangeur côté source
SQU	utility side exchanger flow switch	Stromungswächter Nennleistung	fujistato intercambiador lato equipo	flussstato scambiatore lato utilizzo	contrôleur de débit échangeur côté utilisateur
SQR	Flow switch for heat recovery exchanger	Stromungswächter Rückgewinnung	fujistato por intercambiador a recuperación de calor	Flussstato per scambiatore recupero di calore	Contrôleur de débit pour échangeur récupération de chaleur
CU	use call	Verbrauchsanruf	llamada en utilización	Chiamata utilizzo	appel utilisation
CR	remote heat recovery enabling selector	Fernwahlschalter Rückgewinnung	selector remoto de habilitación para la recuperación	selettore remoto di abilitazione al recupero	sélecteur déporté de validation récupération
SA-ACS	sanitary water cycle selector	Wahlschalter der Brauchwasser	selector solicitud agua sanitaria	selettore richiesta acqua sanitaria	sélecteur demande eau sanitaire
SA1.1	second set-point enabling switch	Wahlschalter 2.Sollwert	selector habilitación segundo set-point	selettore abilitazione secondo set-point	sélecteur validation deuxième consigne
ACS	valve ACS	Idm ACS	Valvula de ACS	valvola ACS	Valve ACS
ALM	Cumulative alarm block	Signallampe Verdichtierzustand	señalización bloqueo acumulativo	segnalazione blocco cumulativo	signalisation alarme

collegamenti a cura del cliente  
connections performed by customer  
raccordements à la charge du client  
Kundenseitige Anschlüsse  
conexiones a cargo del cliente

dwg.n. WD8U02400

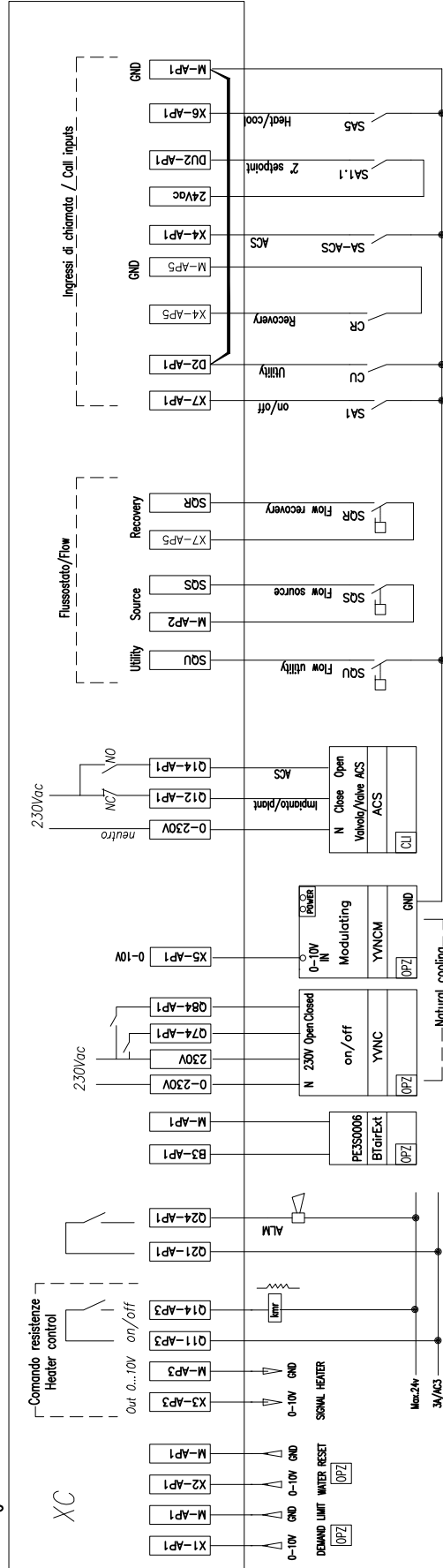

## 5.6 Computer connection

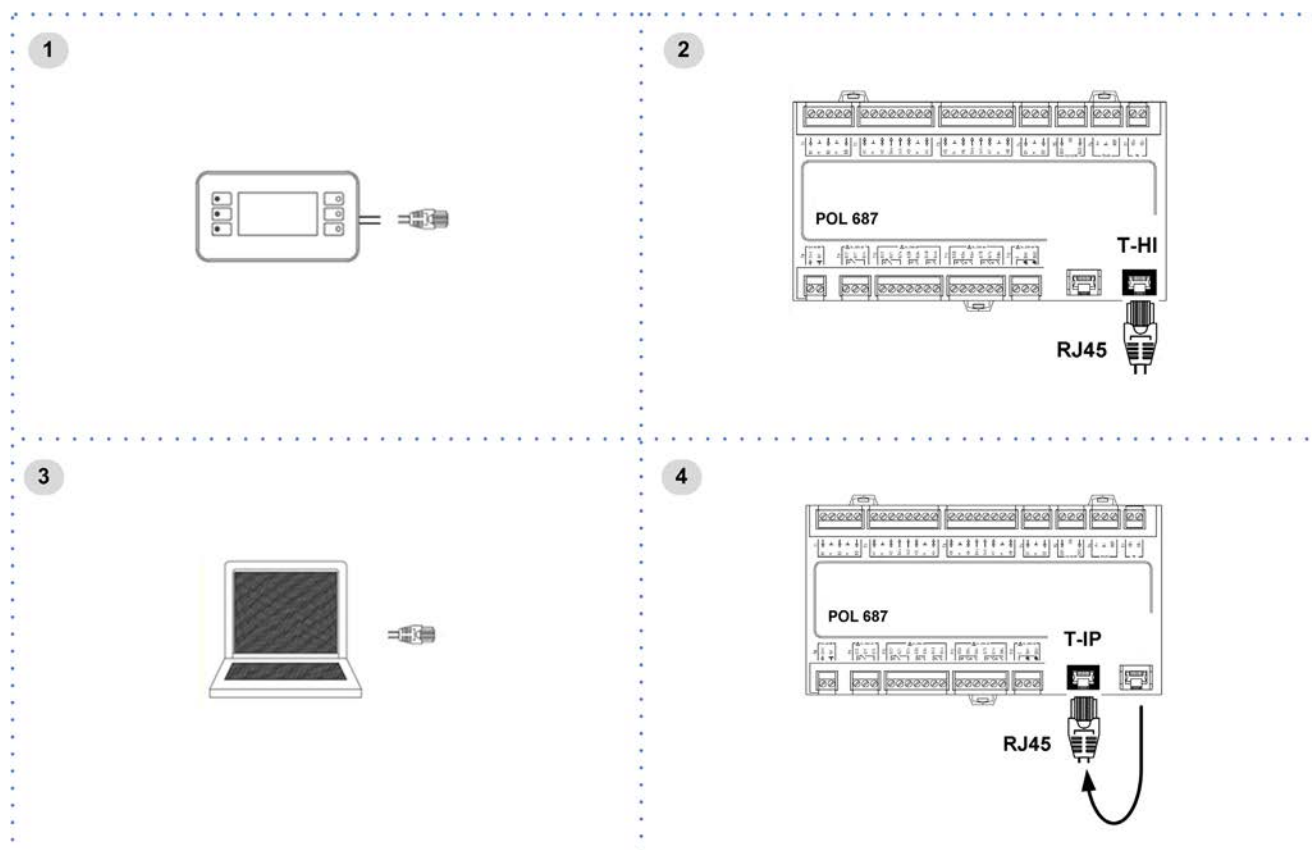

1. Service keypad
2. RJ45: standard connection
3. P.C.-not supplied
4. P.C. connection, shift RJ45 from T-HI to T-IP

### Configu e P.C.

1. connect P.C. and main module with LAN cable
2. check in the taskbar that the connection is active
3. open Control Panel and select Network and sharing center
4. select Modify board setting
5. select Local area connection (LAN)
6. select Internet protocol version 4 (TPC) IPV4 and enter Property
7. set the IP address 192.168.1.100
8. set Subnet mask as 255.255.255.0
9. confi m (OK)
10. enter Start (Windows button)
11. write the command cmd and enter/do it
12. write and run the command Ping 192.168.1.42
13. the message, connection is OK, will appear when successful
14. enter the browser (Chrome, Firefox ecc)
15. write and run the command http://192.168.1.42
16. Userid = WEB
17. Password = SBTAdmin!

## 5.7 Remote control

Option

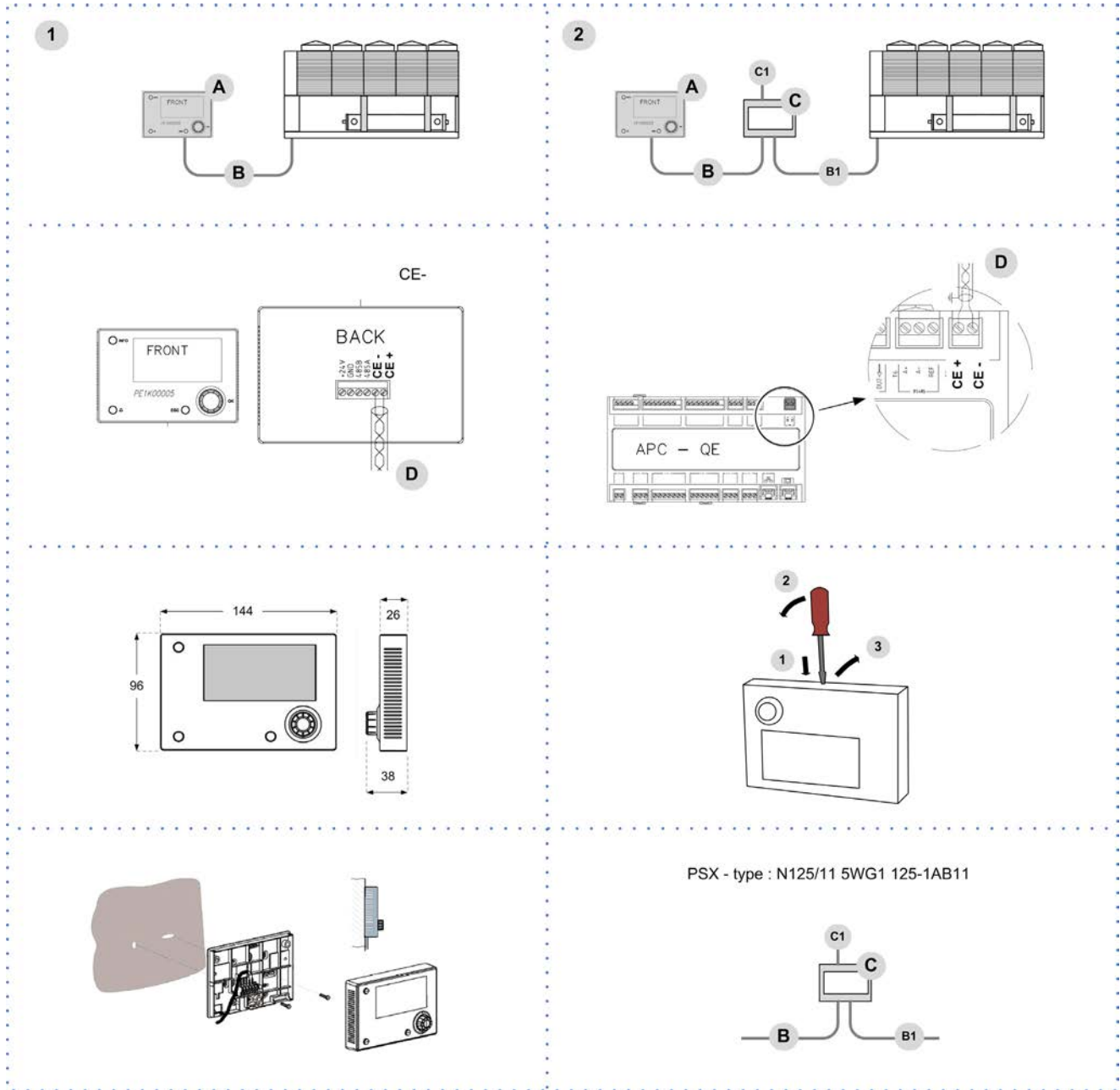

- 1 Distance up to 350 mt
- 2 Distance up to 700 mt

- A User interface
- B = B1 KNX bus, max 350 mt  
twisted pair with shield,  $\varnothing$  0,8 mm  
EIB/KNX cable marking recommende
- C PSX - Mains power supply unit  
pwer supply unit N125/11 5WG1 125-1AB11
- C1 AC 120...230V, 50...60Hz
- D KNX bus, max 350 mt



## 5.8 Modbus - RS485

Option

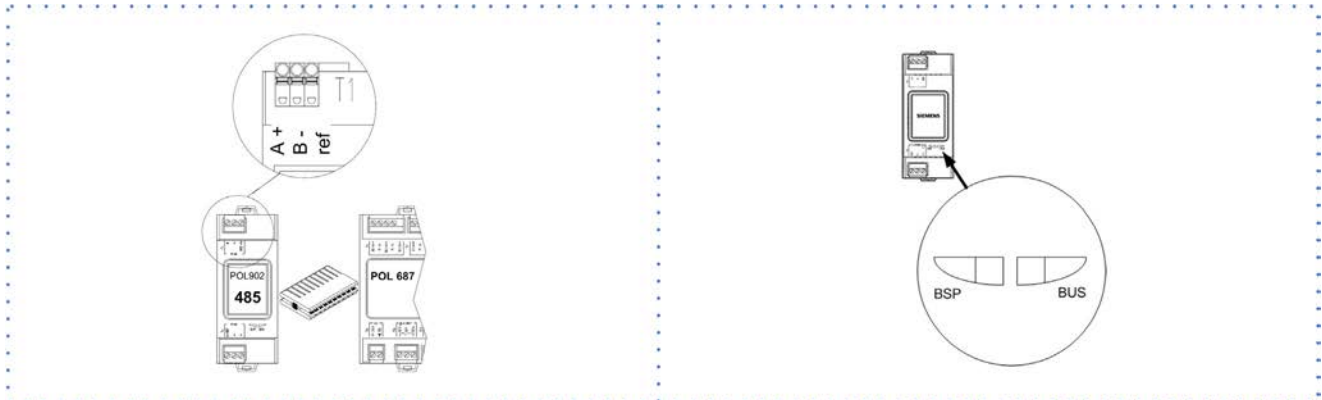

LED BSP  
green communication with AP1 module  
yellow communication ok  
red software ok but communication with AP1 down  
flashing: software error  
flashing: hardware error

LED BUS  
green communication ok  
yellow startup / channel not communicating  
red communication down

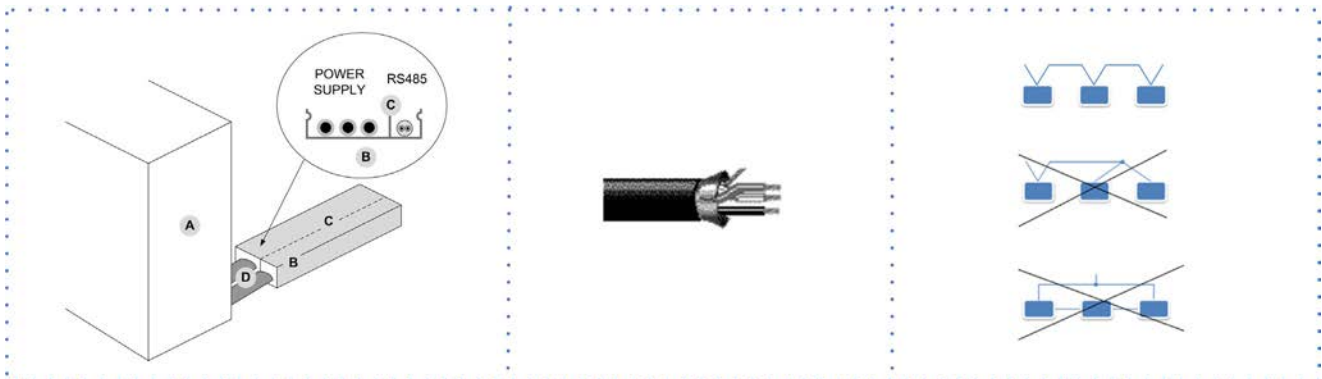

- A. Unit
- B. Metal conduit
- C. Metal septums
- D. Metal-lined sheath (sleeve)

### Modbus / LonWorks / Cable requirements

Couple of conductors twisted and shielded

Section of conductor 0,22mm<sup>2</sup>...0,35mm<sup>2</sup>

Rated power between conductors <math>\leq 50 \text{ pF/m}</math>

Nominal impedance 120  $\Omega$

Recommended cable BELDEN 3106A

- Every RS485 serial line must be set up using the 'In/Out' bus system.
- Other types of networks are not allowed, such as Star or Ring networks.
- The difference in potential between the earth of the two RS485 devices that the cable shielding needs to be connected to must be lower than 7 V
- There must be suitable arresters to protect the serial lines from the effects of atmospheric discharges
- A 120 ohm resistance must be located on the end of the serial line. Alternatively, when the last serial board is equipped with an internal terminator, it must be enabled using the specific jumper, dip switch or link.
- The cable must have insulation features and non-flame propagation in accordance with applicable regulations.
- The RS485 serial line must be kept as far away as possible from sources of electromagnetic interference.

## 5.9 LonWorks

Option

**LonWorks**

**LONWORK CABLE TYPE**  
 Echelon allows three cable types for channel type TP/FT-10, including the Category 5 network cable used commonly in building automation and control (TIA 568A Cat-5).

**CAT-5 SPECIFICATIONS**  
 Unshielded cable, twisted pair with at least 18 beats per meter:

- Cross-sectional area Min.  $\varnothing$  0.5mm, AWG24, 0.22mm<sup>2</sup>
- Impedance 100 +/- 15% @ f > 1 MHz
- Operating capacity between two wires of a pair < 46 nF/km
- Capacity pair to ground, asymmetric. < 3.3 nF/km
- DC loop resistance < 168  $\Omega$

LED BSP      communication with AP1 module  
 green        communication ok  
 yellow      software ok but communication with AP1  
                  down  
 red          flashing: software error  
                  fi ed: hardware error

LED BUS     communication with LonWorks  
 green        ready for communication  
 yellow      startup  
 red          flashing: communicating not possible  
                  communication down

## 5.10 BACnet IP

Option

**BACnet**

Ethernet 10/100 Mbit (IEEE 802.3U)  
 Cable connection RJ45 jack, 8 pins

LED BSP     communication with AP1 module  
 green        communication ok  
 yellow      software ok but communication with AP1  
                  down  
 red          flashing: software error  
                  fi ed: hardware error

LED BUS     communication with BACnet  
 green        ready for communication  
 yellow      startup  
 red          BACnet server down  
                  restart after 3 sec

## 6 Start-up

### 6.1 General description

The indicated operations should be done by qualified technician with specific training on the product.

The electrical, water connections and the other system works are by the installer.

Upon request, the service centres performing the start-up.

Agree upon in advance the start-up data with the service centre.

For details refer to the different manual sections.

Before checking, please verify the following:

- the unit should be installed properly and in conformity with this manual
- the electrical power supply line should be isolated at the beginning
- the unit isolator is open, locked and equipped with the suitable warning
- make sure no tension is present



After turning off the power, wait at least 5 minutes before accessing to the electrical panel or any other electrical component.



Before accessing check with a multimeter that there are no residual stresses.

### 6.2 Preliminary checks

#### Unit OFF power supply

1. safety access
2. functional spaces
3. structure integrity
4. unit on vibration isolators
5. unit input water filter + shut-off valves for cleaning
6. vibration isolators on water connections
7. expansion tank (indicative volume = 5% system content)
8. minimum system water content
9. cleaned system
10. loaded system + possible glycol solution + corrosion inhibitor
11. system under pressure
12. vented system
13. refrigerant circuit visual check
14. earthing connection
15. power supply features
16. electrical connections provided by the customer

### 6.3 Start-up sequence

Unit ON power supply

1. compressor crankcase heaters operating at least since 8 hours
2. off-load voltage measure
3. phase sequence check
4. pump manual start-up and flow check
5. shut-off valve refrigerant circuit open
6. unit ON
7. load voltage measure and absorptions
8. liquid sight glass check (no bubbles)
9. measure return and supply water temperature
10. measure super-heating and sub-cooling
11. check no anomalous vibrations are present
12. climatic curve personalization
13. climatic curve personalization
14. scheduling personalization
15. complete and available unit documentation

## 6.4 Refrigeration circuit

1. Check carefully the refrigerating circuit: the presence of oil stains can mean leakage caused by transportation, movements or other).
2. Verify that the refrigerating circuit is in pressure: Using the unit manometers, if present, or service manometers.
3. Make sure that all the service outlets are closed with proper caps; if caps are not present a leak of refrigerant can be possible.
4. Open the valves of the refrigerant circuit, if there are any.

## 6.5 Water circuit

1. Before realizing the unit connection make sure that the hydraulic system has been cleaned up and the cleaning water has been drained.
2. Check that the water circuit has been filled and pressurized.
3. Check that the shut-off valves in the circuit are in the "OPEN" position.
4. Check that there isn't air in the circuit, if required, evacuate it using the air bleed valve placed in the system high points.
5. When using antifreeze solutions, make sure the glycol percentage is suitable for the type of use envisaged.



Neglecting the washing will lead to several filter cleaning interventions and at worst cases can cause damages to the exchangers and the other parts.

Weight of glycol (%)	10	20	30	40
Freezing temperature (°C)	-3.9	-8.9	-15.6	-23.4
Safety temperature (°C)	+1	-4	-10	-19

## 6.6 Electric Circuit



Verify that the unit is connected to the ground plant.

Check the conductors are tightened as: the vibrations caused by handling and transport might cause these to come loose.

Connect the unit by closing the sectioning device, but leave it on OFF.

Check the voltage and line frequency values which must be within the limits: 400/3/50 +/- 10%

Check and adjust the phase balance as necessary: it must be lower than 2%

Example

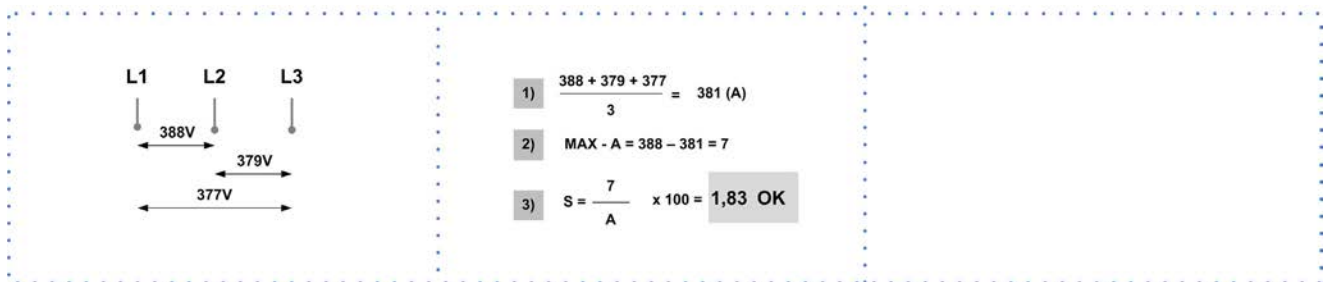

Working outside of these limits can cause irreversible damages and voids the warranty.

## 6.7 Compressor crankcase heaters

Connect the oil resistances on the compressor crankcase at least 8 hours before the compressor is to be started:

- at the first unit start-up
  - after each prolonged period of inactivity
1. Supply the resistances switching off the unit isolator switch.
  2. To make sure that heaters are working, check the power input.
  3. At start-up the compressor crank-case temperature on the lower side must be higher at least of 10°C than the outside temperature.



Do not start the compressor with the crankcase oil below operating temperature.

## 6.8 Remote controls

Check that the remote controls (ON-OFF etc) are connected and, if necessary, enabled with the respective parameters as indicated in the "electrical connections" section.

Check that probes and optional components are connected and enabled with the respective parameters ("electrical connections" section and following pages).

## 6.9 Voltages

Check that the air and water temperatures are within in the operating limits.

Start-up the unit.

With unit operating in stable conditions, check:

- Voltage
- Total absorption of the unit
- Absorption of the single electric loads

## 6.10 Demand limit

⚠ Menu accessible only after having entered the password.

⚠ Access reserved only to specifically trained personnel.

⚠ The parameter modification can cause irreversible damages.

It is possible to limit the absorbed electric power with an external signal 0-10 Vcc.

The higher the signal is, the lower the number of compressors available to meet the thermal need.

If only P0002: EnDemandLimit  $\neq$  0

Path: Main Menu / Unit parameters / Demand limit

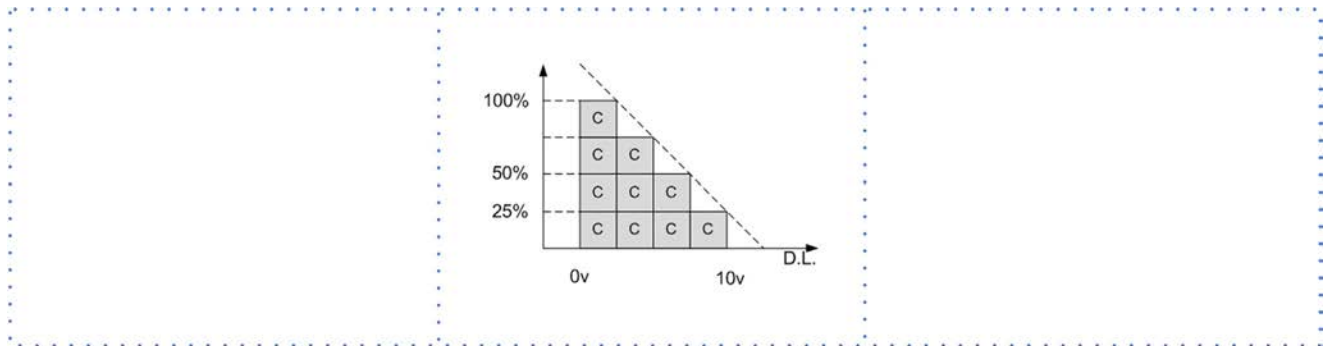

Step	Display	Action	Menu/Variable	Keys		Notes
1		Press 3 sec.		✓		
2	Password	Set	Password	▲	✓	
3		Press		i		
4	Main menu	Select	Unit parameters	▼	✓	
5	Unit parameters	Select	Set Point	▼	✓	
6	Set Point	Select	Demand limit	▼	✓	
7		Set	Demand limit	▲	▼	
8		Confir		✓		
9		Press 3 sec.		⏏		
10		Select	Local connections	✓		

Path: Main Menu / Unit parameters / Demand limit

Parameters	Short description	Description
P0200	setpointdemandlimit	Parameter setting of the value % of demand limit

## 6.11 Climatic Text

Function allows the automatic regulation of the preset set-point depending of the outside temperature air measured by the unit probe.

The setpoint defined by the temperature curve is shown at status S0052: ActualUtSetp

Only if P0036: EnCompExt ≠ 0

Path: Main Menu / Unit parameters / TExt Correction confi

- Menu accessible only after having entered the password.
  - Access reserved only to specifically trained personnel.
  - The parameter modification can cause irreversible damages.
- Example

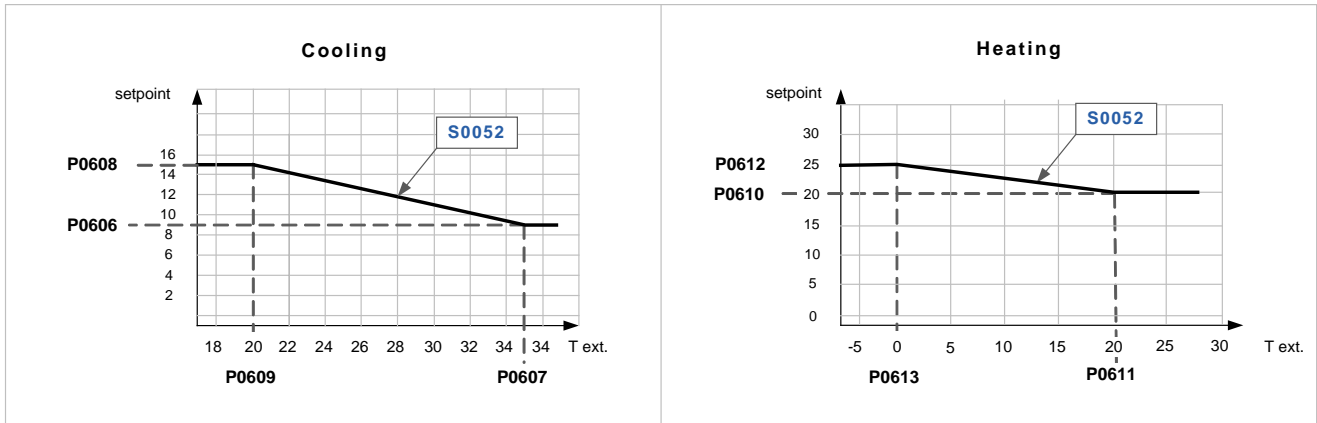

Step	Display	Action	Menu/Variable	Keys		Notes
1		Press 3 sec.				
2	Password	Set	Password			
3		Press				
4	Main menu	Select	Unit parameters			
5	Unit parameters	Select	Climatic TExt			
6	Climatic TExt (pwd)	Select	Parameter			
7		Set				
8		Confir				
9		Press 3 sec.				
10		Select	Local connections			

Path: Main Menu / Unit parameters / TExt Correction confi

Parameters	Short description	Description
P0606	CSptLow	setpoint temperature value when the air temperature value is AirAtSptLowC
P0607	AirAtSetPointLowC	external air temperature value where the calculated setpoint takes on the value given by CSptLow
P0608	CSptHigh	setpoint temperature value when the air temperature value is AirAtSptHigC
P0609	AirAtSetPointHighC	external air temperature value where the calculated setpoint takes on the value given by CSptHigh
P0610	HSptLow	setpoint temperature value when the air temperature value is AirAtSptLowH
P0611	AirAtSptLowH	external air temperature value where the calculated setpoint takes on the value given by HSptLow
P0612	HSptHigh	setpoint temperature value when the air temperature value is AirAtSptHighH
P0613	AirAtSptHighH	external air temperature value where the calculated setpoint takes on the value given by HSptHigh

## 6.12 Water reset

- ⚠ Menu accessible only after having entered the password.
- ⚠ Access reserved only to specifically trained personnel.
- ⚠ The parameter modification can cause irreversible damages.  
The water reset correction affects the setpoint defined by the Climate curve TExt (actual setpoint).  
The setpoint is shown at status S0052: ActualUtSetp  
Only if P0003: En WaterReset ≠ 0  
Path: Main menu / Unit parameters / Water reset confi

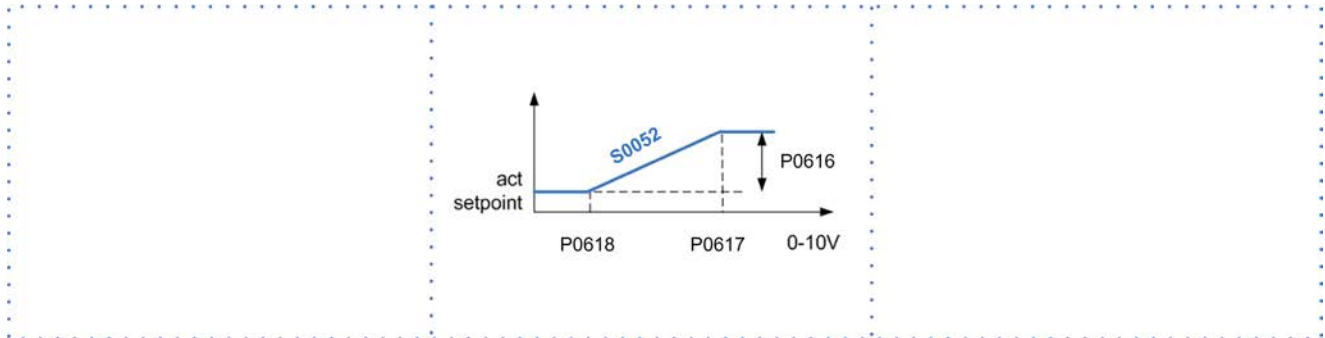

Step	Display	Action	Menu/Variable	Keys		Notes
1		Press 3 sec.		✓		
2	Password	Set	Password	▼	✓	
3		Press		i		
4	Main menu	Select	Unit parameters	▼	✓	
5	Unit parameters	Select	Water reset	▼	✓	
6	Water reset	Select	Parameter	▼	✓	
7		Set		▼	▲	
8		Confir		✓		
9		Press 3 sec.		⏏		
10		Select	Local connections	✓		

Path: Main Menu / Unit parameters / Water reset

Parameters	Short description	Description
P0616	MaxCWRC	Maximum correction to be applied to the setpoint Cooling
P0617	SWRMaxC	Value of the WR control signal corresponding to the correction of the set Cool equal to P0616
P0618	SWRMinC	Value of the WR control signal corresponding to the correction of the set COOL equal to 0
P0615	MaxCWRH	Maximum correction to be applied to the setpoint Heating
P0619	SWRMaxH	Value of the WR control signal corresponding to the correction of the set Heating equal to P0615
P0620	SWRMinH	Value of the WR control signal corresponding to the correction of the set Heating equal to 0

P0616 / P0618: Cooling  
P0615, P0619, P0620: Heating

## 6.13 ECOSHARE function for the automatic management of a group of units

- Max 7 units
- Maximum length of the bus line: 700 m.
- Maximum distance between 2 units: 300 m
- Type of cable: shielded twisted pair cable  $\varnothing$  0,8 mm. use an EIB/KNX cable
- Possible connections: Tree, star, in/out bus, mixed
- It is not possible to use a ring connection
- No end-of-line resistor or terminator required
- There must be suitable arresters to protect the serial lines from the effects of atmospheric discharges
- The data line must be kept separate from the power conductors or powered at different voltage values and away from possible sources of electrical interference

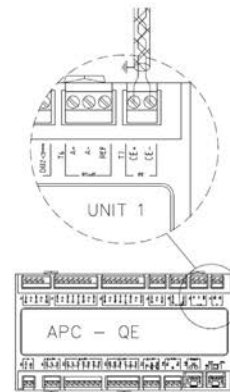
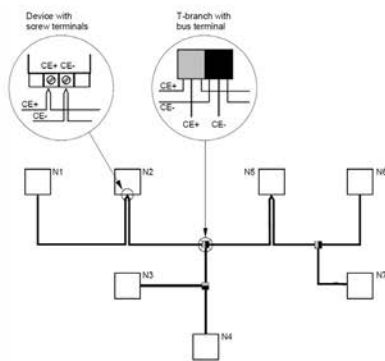

Tree topology (with stub lines)

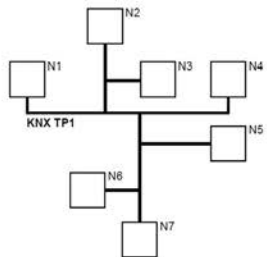

Line topology (with loops)

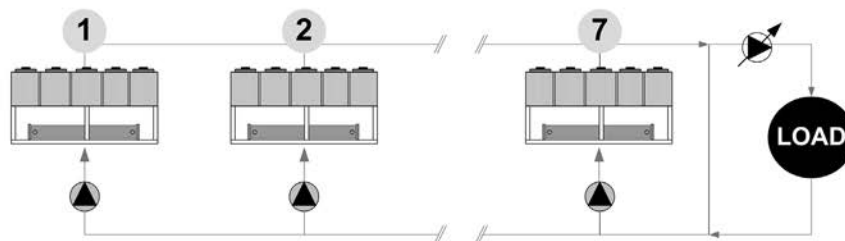
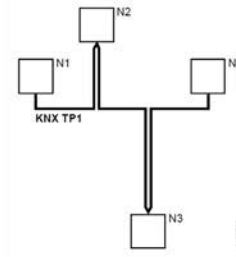



If there are more units connected in a local network set the mode of operation.

**MODE A**

Every unit manages its own compressors according to the setpoint.

Every unit optimizes its refrigeration circuits.

Pumps always active, even with compressor stoped.

P0658 = 0

P0657 > 0 °C

setpoint1 > setpoint2 > setpoint3

or

setpoint1 < setpoint2 < setpoint3

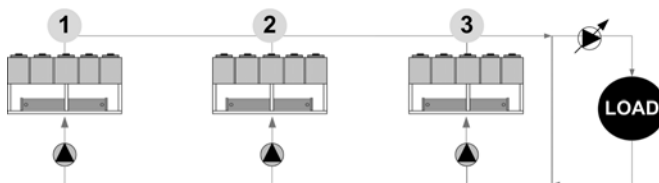

**MODE B**

The master manages the single cooling.

The master optimizes individual refrigerant circuits.

Pumps always active, even with compressor stoped.

P0658 = 1

P0657 = 0 °C

setpoint1 = setpoint2 = setpoint3

plus: optimal H2O temperature control

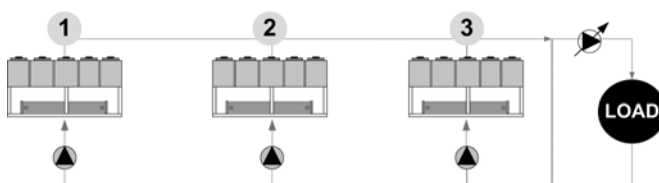

**MODE C**

The master manages the single cooling.

The master optimizes individual refrigerant circuits.

Active pumps only with active compressors.

P0658 = 2

P0657 = 0 °C

setpoint1 = setpoint2 = setpoint3

plus: minimum pumps consumption need balanced system (t1 = t2 = t3)

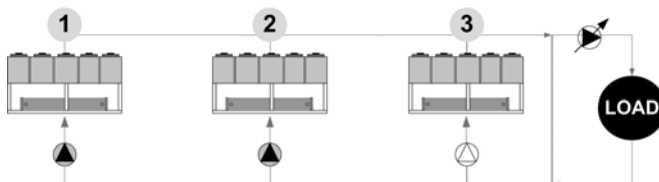

Path: Main Menu / Unit parameters / Master Slave

Parameters	Short description	Description
P0655	LNInstalledUnits	Number of network-connected units including the master
P0656	LNStandByUnits	Number of units kept in standby
P0657	LNOffset	Temperature Offset the master sum or subtract, depending on the way you set, in order of priority, to the set point of the slave
P0658	TypeRegMS	Operation mode: 0=mode A; 1=mode B; 2=mode C
P0659	LNAddress	ProcessBus address unit

## 6.14 Evaporator water flow rate

Check that the difference between the temperature of exchanger return and supply water corresponds to power according to this formula:  

$$\text{unit cooling power (kW)} \times 860 = \Delta t (\text{°C}) \times \text{flow rate (L/h)}$$

The cooling power is shown in the table of the GENERAL TECHNICAL DATA included in this manual, referred to specific conditions, or in the tables on COOLING PERFORMANCE in the TECHNICAL BULLETIN referred to various conditions of use.

Check for water side exchanger pressure drops:

determine the water flow rate

measure the difference in pressure between exchanger input and output and compare it with the graph on WATER SIDE EXCHANGER PRESSURE DROPS

The measurement of pressure will be easier if pressure gauges are installed as indicated in the DIAGRAM OF SUGGESTED WATER CONNECTIONS.

## 6.15 Scroll compressor

The Scroll compressors have only one rotation direction.

In the event it is reversed, the compressor is not immediately damaged, but increases its noise and jeopardises pumping.

After a few minutes, the compressor blocks due to intervention of the thermal protection.

In this case, disconnect power supply and invert 2 phases on the machine power supply.

Avoid the compressor working for a long time with contrary rotation: more than 2-3 of these anomalous start-ups can damage it.

To ensure the rotation direction is correct, measure the condensation and suction pressure.

The pressures must significantly differ: upon start-up, the suction pressure decreases whereas the condensation one, increases.

## 6.16 Operating at reduced load

The units are equipped with partialization steps and they can, therefore, operate with reduced loads.

However a constant and long operation with reduced load with frequent stop and start-up of the compressor/s can cause serious damages for the lack of oil return.

The above-described operating conditions must be considered outside the operating limits.

In the event of compressor breakdown, due to operating in the above-mentioned conditions, the guarantee will not be valid and Clivet spa declines any responsibility.

Check periodically the average operating times and the frequency of the compressors starts: approximately the minimum thermal load should be such as to need the operating of a compressor for at least ten minutes.

If the average times are close to this limit, take the proper corrective actions.

## 6.17 Start-up report

Identifying the operating objective conditions is useful to control the unit over time.

With unit at steady state, i.e. in stable and close-to-work conditions, identify the following data:

- total voltages and absorptions with unit at full load
- absorptions of the different electric loads (compressors, fans, pumps etc)
- temperatures and flows of the different fluids (water, air) both in input and in output from the unit
- temperature and pressures on the characteristic points of the refrigerating circuit (compressor discharge, liquid, intake)

The measurements must be kept and made available during maintenance interventions.

## 6.18 2014/68/UE PED directive

DIRECTIVE 2014/68/UE PED gives instructions for installers, users and maintenance technicians as well.

Refer to local regulations; briefly and as an example, see the following:

Compulsory verification of the first installation:

- only for units assembled on the installer's building site (for ex. Condensing circuit + direct expansion unit)

Certification of setting in service:

- for all the units

Periodical verifications:

- to be executed with the frequency indicated by the Manufacturer (see the "maintenance inspections" paragraph)

## 7 Control

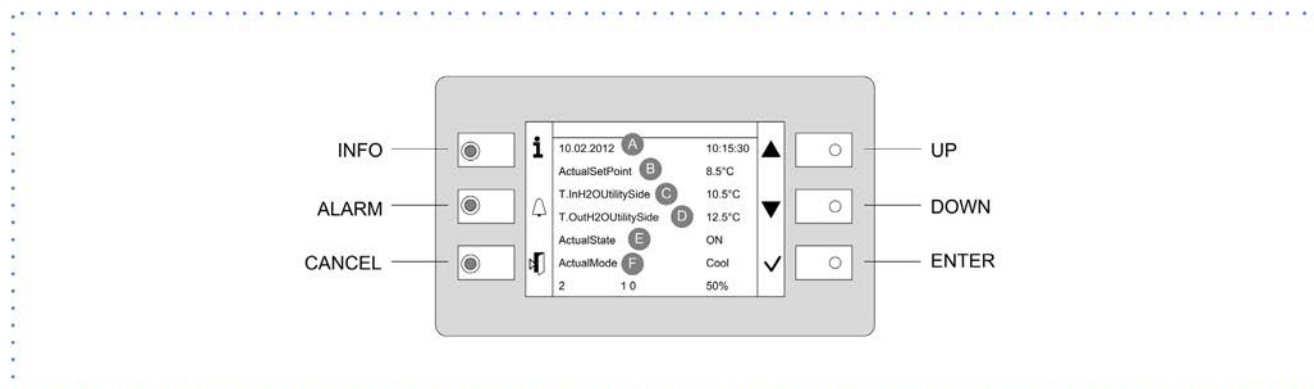

### 7.1 Led

INFO	Not used
ALARM	Blink / fi ed = alarm present
CANCEL	not used currently

Heat: Heating (not used)

### 7.2 Display

Ref.	Variable	Description
A		Date - Time
B	<b>ActualSetPoint</b>	Temperature setting
C	<b>T.InH2OUtilitySide</b>	Water inlet temperature utility side
D	<b>T.OutH2OUtilitySide</b>	Water outlet temperature utility side
E	<b>ActualState</b>	On / off / e o / pmp On
F	<b>ActualMode</b>	Cool: water cooling Heat: HEATING
	2	Installed compressors
	1 - 0	Compressors ON example: circuit 1 = 1 compr. On circuit 2 = 0 compr. On
	50%	Heating capacity

### 7.3 Keys

Symbol	Name	Description
	Info	Main menu
	Alarm	Alarm display
	Cancel	Exit Previous level Keyboard settings
	Up	Increases value
	Down	Decreases value
	Enter	Confir Password

## 7.4 Change unit state

Step	Display	Action	Menu/Variable	Keys		Notes
1		Press				
2	Main menu	Select	Cmd Local state			
3		Set	OFF - ECO - ON - Pump On			*
4		Confir				
6		Exit				

\* Local state

ECO: recurrent pump ON-OFF; compressors keep water system at setpoint ECO

Pmp ON: pump ON, compressor OFF

## 7.5 Change the mode

Step	Display	Action	Menu/Variable	Keys		Notes
1		Press				
2	Main menu	Select	Cmd Local mode			
3		Set	Cool: water cooling Heat: HEATING			
4		Confir				
5		Exit				

















## 7.6 Modify setpoint

Step	Display	Action	Menu/Variable	Keys		Notes
1		Press				
2	Main menu	Select	Unit parameters			
3	Unit parameters	Confir	Set Point			
4		Select	Set Point			
5		Set	Set Point			
6		Confir				
7		Exit				













Parameters	Short description	Description	
P0583	SetPointCooling	Setpoint Cool	
P0584	2SetPointCooling	2° Setpoint Cool	Enable by remote switch
P0855	SetPointECOcooling	Economic summer SetPoint	
P0577	SetPointHeating	Setpoint Heat	
P0578	2SetPointHeating	2° Setpoint Heat	
P0579	SetPointECOHeating	Economic winter SetPoint	
P0640	SetPointRecover	Recovery Set Point	
P0580	ACSSetPoint	domestic hot water set point	

## 7.7 Scheduler

It is possible to set 6 events (Off, Eco, On, Recirculating) for each week day.







Step	Display	Action	Menu/Variable	Keys		Notes
1		Press				
2	Main menu	Select	Scheduler			
3	Scheduler	Select	Day			
4		Select	Time			
5		Set	Event time			
6		Confir				
7		Select	Value			
8		Set	On/Eco..			
9		Confir				
10		Exit				

### Enable Scheduler

Step	Display	Action	Menu/Variable	Keys		Notes
1		Press 3 sec.				
2	Password	Set	Password			
3		Press				*
4	Main menu	Select	Unit Parameters			
5		Select	Option confi			
6		Set	P0052=1			
7		Press 3 sec.				
		Select	Local connections			

\* Unit Parameters menu is displayed

## 7.8 Display the status

Step	Display	Action	Menu/Variable	Keys		Notes
1		Press				
2	Main menu	Select	Machine State			
3		Select	General, circuit, ecc..			
4		Exit				

Nr.	GENERAL STATA
50	Current Mode
51	Current Status
52	Current Setpoint User-side
53	Steps Qty
54	Steps On
55	Current Setpoint Recovery
56	Alarms
57	Warning
58	Recovery Request
59	User-side Request
60	Domestic Hot Water Status
801	Recovery Pump 1 Hours
802	Recovery Pump 2 Hours
803	Recovery Pump 3 Hours
-	Bitmap Alarms 1
-	Bitmap Alarms 2
-	Bitmap Alarms 3
-	Bitmap Alarms 4

Nr.	USER-SIDE STATA
80	User-side Pump 1 Command
81	User-side Pump 2 Command
82	User-side Pump 3 Command
83	User-side Inverter Command
84	User-side Inverter Signal
85	User-side Inverter Reset
86	Pump On for Anti-freeze
87	Anti-freeze Heaters User side
88	User-side Flow Request
89	LimitFlow Heating
90	LimitFlow Recovery
91	LimitFlow Cooling
92	User-side Pump 1 Hours
93	User-side Pump 2 Hours
94	User-side Pump 3 Hours

Nr.	SOURCE STATA
70	Source Pump 1 Command
71	Source Pump 2 Command
72	Source Pump 2 Command
73	Source Inverter Command
74	Source Inverter Signal
75	Source Inverter Reset
1601	Source Pump 1.1 Hours
1602	Source Pump 2.1 Hours
1603	Source Pump 3.1 Hours
2601	Source Pump 1.2 Hours
2602	Source Pump 2.2 Hours
2603	Source Pump 3.2 Hours

Nr	CIRCUIT 1 STATA
1001	Current Schema 1.1
1002	SubCooling
1003	Current capacity %
1004	Pressure ratio
1005	Envelope Zone 1.1
1006	Envelope Zone 2.1
1007	Envelope Zone 3.1
1008	Offset Envelope 1.1
1009	Superheat Set PID 3.1
1100	Defrost Command 1.1
1101	Superheat Set PID 1.1
1102	Superheat Set PID 2.1
1103	Number Compressors On
1104	Compressor 1.1 Starts
1105	Compressor 2.1 Starts
1106	Compressor 3.1 Starts
1107	Compressor 1.1 Hours
1108	Compressor 2.1 Hours
1109	Compressor 3.1 Hours
-	EEV PID 1 controller status
-	EEV PID 2 controller status
-	EEV PID 3 controller status
-	Source EEV 1
-	Source EEV 2
-	User-side EEV
-	Bitmap Alarms 1.1
-	Bitmap Alarms 2.1
-	Bitmap Alarms 3.1
-	Bitmap Alarms 4.1

Nr.	DIGITAL INPUT
100	2nd Setpoint User-side
101	Recovery System Load
102	User-side System Load
103	Domestic Hot Water Request
104	Recovery Request
105	User-side Request
106	F.C. O. YV Cool
107	F.C. O. YV Heat
108	F.C. C. YV Cool
109	F.C. C. YV Heat
110	Free-cooling Flow
111	Recovery Flow
112	Source Flow
113	User-side Flow
114	Remote Heat/Cool
115	Remote On/Off
116	Phase Monitor
117	Free-cooling Pressure
118	Recovery Inverter Protection
119	Source Inverter Protection
120	User-side Inverter Protection
121	Free-cooling Pump 1 Protection
122	Recovery Pump 1 Protection
123	Source Pump 1 Protection
124	User-side Pump 1 Protection
125	Free-cooling Pump 2 Protection
126	Recovery Pump 2 Protection
127	User-side Pump 2 Protection
128	Free-cooling Pump 3 Protection
129	Recovery Pump 3 Protection
130	Source Pump 3 Protection
131	User-side Pump 3 Protection
132	Leak Detector
138	Source Pump 2 protection
139	Source System Load
1180	High Pressure 1.1
1181	Compressor 1.1 Protection
1182	Compressor 2.1 Protection
1184	Source Fan 1.1 Protection
2180	High Pressure 1.2
2181	Compressor 1.2 Protection
2183	Compressor 2.2 Protection
2184	Source Fan 1.2 Protection









Nr.	ANALOGIC INPUT
201	Demand Limit
202	User-side Differential Pressure switch
203	Free-cooling Water Temperature
204	External Air Temperature
205	Recovery In Temperature
206	Recovery Out Temperature
207	Cabinet Temperature
208	Water Reset
830	User-side In Temperature
831	User-side Out Temperature
885	Source In Temperature
886	Source Out Temperature
1201	Suction Pressure 1.1
1202	Suction Pressure 2.1
1203	Discharge Pressure 1.1
1204	Suction Temperature 1.1
1205	Suction Temp 2.1
1206	Suction Temperature 3.1
1207	Source In Temperature 1.1
1208	Recovery Liquid Temperature 1.1
1209	Source Out Temperature 1.1
1210	Discharge Temperature 1.1
1211	Discharge Temperature 2.1
2201	Suction Pressure 1.2
2202	Suction Pressure 2.2
2203	Discharge Pressure 1.2
2204	Suction Temperature 1.2
2205	Suction Temperature 2.2
2206	Suction Temperature 3.2
2207	Source In Temperature 1.2
2208	Recovery Liquid Temperature 1.2
2209	Source Out Temperature 1.2
2210	Discharge Temperature 1.2
2211	Discharge Temperature 2.2

Nr.	OUTPUT ANALOGICI
301	User-side YV Bypass
302	Grouped Alarms
303	Free-cooling Pump 1
304	Recovery Pump 1
305	Free-cooling Pump 2
306	Recovery Pump 2
307	Free-cooling Pump 3
308	Recovery Pump 3
309	Anti-freeze Heaters
310	Free-cooling Heaters
311	Cabinet Heating
312	Cabinet Fan
313	Domestic Hot Water Valve
314	Free-cooling Valve Open
315	Free-cooling Valve Close
318	YV 1 Cooling
319	YV 2 Heating
320	YV 3 Cooling
321	YV 4 Heating
1301	Aries / Defrost Injection 1.1
1302	Source Pump 1.1 Command
1303	Compressor 1.1 Command
1304	Compressor 2.1 Command
1305	Liquid Injection 1.1
1306	Liquid Injection 2.1
1307	RecValve Battery 1.1
1308	RecValve Chiller 1.1
1309	RecValve Recovery 1.1
1310	Reversing Cycle Valve 1.1
2301	Aries / Defrost Injection 1.2
2302	Source Pump 2.1 Command
2303	Compressor 1.2 Command
2304	Compressor 2.2 Command
2305	Liquid Injection 1.2
2306	Liquid Injection 2.2
2307	RecValve Battery 1.2
2308	RecValve Chiller 1.2
2309	RecValve Recovery 1.2
2310	Reversing Cycle Valve 1.2

Nr.	ANALOGIC OUTPUT
401	Free-cooling Valve
402	Recovery Pump Signal
1401	Source Fan 1.1
2401	Source Fan 1.2

















## 7.9 Keyboard settings

Step	Display	Action	Menu/Variable	Keys		Notes
1		Press 3 sec.				
2		Press				
3	HMI Settings	Select				
4		Press				
5		Press				
6		Select	Local connections			

## 7.10 Alarms

-  Before resetting an alarm identify and remove its cause.  
Repeated resets can cause irreversible damage.  
Example:  
+ eE0001: Phase monitor: Fault = active alarm  
- EE0003: Pum 1 faulty: Ok = resetted alarm  
Display of alarm: step 1-3  
Reset allarm: step 4-10

Step	Display	Action	Menu/Variable	Keys		Notes
1		Press				
2	Alarm list detail	Press				
3	Alarm list	Select	Alarm			
4	Alarm list detail	Press 3 sec.				
5	Password	Set	Enter password			
6	Alarm list detail	Press				
7	Alarm list	Select	Alarm			
8		Select	Reset Executed			
9		Press 3 sec.				
10	Password management	Select	Log off			

For details see:  
General list of alarms

## 7.11 General list of alarms

Num	Description
eE0001	Phase monitor fault
EE0003	User side pump 1 overload protection
EE0004	User side pump 2 overload protection
EE0005	User side pump 3 overload protection
eE0008	User side inverter overload protection
ee0010	Master unit offline
ee0011	2 <sup>nd</sup> slave unit fault
ee0012	2 <sup>nd</sup> slave unit offline
ee0013	3 <sup>rd</sup> slave unit fault
ee0014	3 <sup>rd</sup> slave unit offline
ee0015	4 <sup>th</sup> slave unit fault
ee0016	4 <sup>th</sup> slave unit offline
ee0017	5 <sup>th</sup> slave unit fault
ee0018	5 <sup>th</sup> slave unit offline
ee0019	6 <sup>th</sup> slave unit fault
ee0020	6 <sup>th</sup> slave unit offline
ee0021	7 <sup>th</sup> slave unit fault
ee0022	7 <sup>th</sup> slave unit offline
ee0027	User side in water temperature probe fault
ee0028	User side out water temperature probe fault
ee0029	External air temperature probe fault
ee0030	Demand limit fault
ee0031	Water reset fault
ee0032	Relative humidity probe fault
ee0033	Electrical panel temperature probe fault
ee0035	YV Cool opening fault
ee0036	YV Heat opening fault
ee0037	YV Cool closing fault
ee0038	YV Heat closing fault
ee0040	Freecooling water temperature probe fault
EE0044	Freecooling pump 1 overload protection
EE0045	Freecooling pump 2 overload protection
EE0046	Freecooling pump 3 overload protection
ee0047	Switching pump on user side for flow alarm
ee0050	User side differential pressure sensore fault
EE0054	Recovery side pump 1 overload protection

Num	Description
EE0055	Recovery side pump 2 overload protection
EE0056	Recovery side pump 3 overload protection
eE0057	Recovery side inverter overload protection
ee0100	1 <sup>st</sup> POL98U module disconnected
ee0101	2 <sup>nd</sup> POL98U module disconnected
ee0102	POL96U module disconnected
ee0103	POL945 module disconnected
ee0104	POL965 module disconnected
ee0105	1 <sup>st</sup> POL94U module disconnected
ee0106	2 <sup>nd</sup> POL94U module disconnected
ee0107	POL985 module disconnected
ee1001	Gas temperature probe 3 fault
ee1002	Gas temperature probe 5 fault
ee1003	Pressure sensor fault, low pressure heating
ee1004	EEV 1 blocked
ee1005	EEV2 blocked
EE1006	Compressor 1 overload protection
EE1007	Compressor 2 overload protection
EE1008	Compressor 3 overload protection
EE1009	Source side inverter overload protection
ee1010	Switching pump on source side for flow alarm
EE1013	Source side pump 1 overload protection
EE1014	Source side pump 2 overload protection
EE1015	Source side pump 3 overload protection
EE1018	Source side ventilation overload protection
ee1022	Compressor 1 discharge temperature probe fault
ee1023	Compressor 2 discharge temperature probe fault
ee1024	Compressor 3 discharge temperature probe fault
ee1025	Source 1 temperature probe fault
ee1026	Source 2 temperature probe fault
ee1027	Suction temperature probe fault
ee1028	High pressure probe fault
ee1029	Low pressure probe fault
ee1030	Recovery exchanger gas temperature probe fault

Num	Description
ee1031	Recovery exchanger gas pressure probe fault
ee1032	Recovery in temperature probe fault
ee1033	Recovery out temperature probe fault
ee1037	Inverter 1 in alarm
ee1038	Inverter 1 Modbus communication error
ee1039	Inverter 1 communication timeout
ee1040	Inverter 2 in alarm
ee1041	Inverter 2 Modbus communication error
ee1042	Inverter 2 communication timeout
ee1043	Inverter 3 in alarm
ee1044	Inverter 3 Modbus communication error
ee1045	Inverter 3 communication timeout
EE1047	Compressor 1 envelope alarm
EE1048	Compressor 2 envelope alarm
EE1049	Compressor 3 envelope alarm
ee1055	Inverter 1 in alarm
ee1056	Inverter 1 Modbus communication error
ee1057	Inverter 1 communication timeout
ee1058	Inverter 2 in alarm
ee1059	Inverter 2 Modbus communication error
ee1060	Inverter 2 communication timeout
ee1061	Inverter 3 in alarm
ee1062	Inverter 3 Modbus communication error
ee1063	Inverter 3 communication timeout
ee1070	User side ECV connection problem
ee1071	Source side ECV 1 connection problem
ee1072	Source side ECV 2 connection problem
ee2001	Gas temperature probe 4 fault
ee2002	Gas temperature probe 6 fault
ee2003	Pressure sensor fault, low pressure heating
ee2004	EEV1 blocked
ee2005	EEV2 blocked
EE2006	Compressor 1 overload protection
EE2007	Compressor 2 overload protection
EE2008	Compressor 3 overload protection
EE2009	Source side inverter overload protection

Num	Description
ee2010	Switching pump on source side for flow alarm
EE2013	Source side pump 1 overload protection
EE2014	Source side pump 2 overload protection
EE2015	Source side pump 3 overload protection
EE2018	Source side ventilation overload protection
ee2022	Compressor 1 discharge temperature probe fault
ee2023	Compressor 2 discharge temperature probe fault
ee2024	Compressor 3 discharge temperature probe fault
ee2025	Source 1 temperature probe fault
ee2026	Source 2 temperature probe fault
ee2027	Suction gas temperature probe fault
ee2028	High pressure probe fault
ee2029	Low pressure probe fault
ee2030	Recovery exchanger gas temperature probe fault
ee2031	Recovery exchanger gas pressure probe fault
ee2032	Recovery in temperature probe fault
ee2033	Recovery out temperature probe fault
ee2037	Inverter 1 in alarm
ee2038	Inverter 1 Modbus communication error
ee2039	Inverter 1 communication timeout
ee2040	Inverter 2 in alarm
ee2041	Inverter 2 Modbus communication error
ee2042	Inverter 2 communication timeout
ee2043	Inverter 3 in alarm
ee2044	Inverter 3 Modbus communication error
ee2045	Inverter 3 communication timeout
EE2047	Compressor 1 envelope alarm
EE2048	Compressor 2 envelope alarm
EE2049	Compressor 3 envelope alarm
ee2055	Inverter 1 in alarm
ee2056	Inverter 1 Modbus communication error
ee2057	Inverter 1 communication timeout
ee2058	Inverter 2 in alarm
ee2059	Inverter 2 Modbus communication error

Num	Description
ee2060	Inverter 2 communication timeout
ee2061	Inverter 3 in alarm
ee2062	Inverter 3 Modbus communication error
ee2063	Inverter 3 communication timeout
ee2070	User side ECV connection problem
ee2071	Source side ECV 1 connection problem
ee2072	Source side ECV 2 connection problem
f1005	Value of refrigerant superheat too low EEV1 (user side)
ff1006	Value of refrigerant superheat too low EEV1 (source)
fF1009	Low Pressure Alarm (DI)
ff1010	Low Pressure Pre Alarm in Cooling Mode
ff1011	Low Pressure Pre Alarm in Heating Mode
fF1012	Low Pressure in Heating Mode (AI)
fF1013	High Pressure Alarm (DI)
ff1014	High Pressure Pre Alarm
fF1015	High Pressure Alarm (AI)
ff1016	Maximum Pressure Ratio Pre Alarm
fF1017	Minimum Pressure Ratio Pre Alarm
fF1018	Low Pressure Alarm in Cooling Mode
FF1019	Maximum Pressure Ratio
FF1034	Vaaccum Alarm
FF1046	Low pressure limit
ff1047	Defrost Forced
ff1048	Low water temperature for defrost operation
ff1049	Defrost Maximum Time
ff2005	Min Superheat value (user side)
ff2006	Min Superheat value (source)
fF2009	Low pressure Alarm (DI)
ff2010	Low pressure Pre Alarm CoolingMode
ff2011	Low pressure Pre Alarm HeatingMode
fF2012	Low pressure Pre Alarm Heating Mode (AI)
fF2013	High pressure Alarm (DI)
ff2014	High pressure Pre Alarm
fF2015	High pressure Alarm (AI)
ff2016	Maximum pressure Ratio Pre Alarm

Num	Description
ff2017	Minimum pressure Ratio Pre Alarm
ff2018	Low Pressure Alarm Cooling Mode
FF2019	Maximum Pressure Ratio
FF2034	Vaaccum Alarm
FF2046	Low pressure limit
ff2047	Defrost Forced
ff2048	Low water temperature for defrost
ff2049	Defrost Time
ii0002	User side low water pressure
ii0006	User side low flow rate
ii0007	User side Water Frost Protection
ii0008	Pump activation Water Frost Protection
ii0009	Water outlet temperature, discordant with the current operation mode, user side
ii0042	Freecooling low water pressure
ii0043	Freecooling water frost protection
ii0047	Freecooling water low flow rate
ii0052	Recovery water low flow rate
ii0053	Recovery low water pressure
ii1017	Source low water pressure
ii1020	Source side low water flow
ii1021	Source side water frost protection
ii2017	Source low water pressure
ii2020	Source side low water flow
ii2021	Source side water frost protection

## 8 Maintenance

### 8.1 General description

Maintenance must be done by authorized centres or by qualified personnel.

The maintenance allows to:

- maintain the unit efficiency
- increase the life span of the equipment
- assemble information and data to understand the state of the unit efficiency and avoid possible damages

Before checking, please verify the following:

- the electrical power supply line should be isolated at the beginning
- the unit isolator is open, locked and equipped with the suitable warning
- make sure no tension is present



After turning off the power, wait at least 5 minutes before accessing to the electrical panel or any other electrical component.



Before accessing check with a multimeter that there are no residual stresses.

### 8.2 Inspections frequency

Perform an inspection every 6 months minimum.

The frequency, however, depends on the use.



In the event of frequent use it is recommended to plan inspections at shorter intervals:

- frequent use (continuous or very intermittent use, near the operating limits, etc)
- critical use (service necessary)

√	intervention frequency (months)	1	6	12
1	presence corrosion			X
2	panel fixing			X
3	water filter cleaning		X	
4	water: quality, ph, weight of glycol (%)		X	
5	check the exchanger efficiency			X
6	circulating pumps		X	
7	check of the fixing and the insulation of the power lead			X
8	check of the earthing cable			X
9	electric panel cleaning			X
10	capacity contactor status			X
11	terminal closing, cable insulation integrity			X
12	voltage and phase unbalancing (no load and on-load)		X	
13	absorptions of the single electrical loads		X	
14	test of the compressor crankcase heaters		X	
15	Checking for leaks			*
16	survey of the refrigerant circuit operating parameters		X	
17	safety valve			*
18	protective device test: pressure switches, thermostats, flow switches etc..		X	
19	control system test: setpoint, climatic compensations, capacity stepping, water / air flow-rate variations		X	
20	control device test: alarm signalling, thermometers, probes, pressure gauges etc..		X	

\* Refer to the local regulations; and ensure correct adherence. Companies and technicians that effect interventions of installation, maintenance/repairs, leak control and recovery must be CERTIFIED as expected by the local regulations. The leak control must be effected with annual renewal.

### 8.3 Unit booklet

It's advisable to create a unit booklet to take notes of the unit interventions.

In this way it will be easier to adequately note the various interventions and aid any troubleshooting.

Report on the booklet:

- date
- intervention description
- carried out measures etc.

### 8.4 Standby mode

If a long period of inactivity is foreseen:

- turn off the power
- avoid the risk of frost (empty the system or add glycol)

Turn off the power to avoid electrical risks or damages by lightning strikes.



With lower temperatures keep heaters turned on in of the electrical panel (option).

It's recommended that the re-start after the stopping period is performed by a qualified technician, especially after seasonal stops or seasonal switching.

When restarting, refer to what is indicated in the "start-up" section.

Schedule technical assistance in advance to avoid hitches and to guarantee that the system can be used when required.

### 8.5 Water side exchanger

It is very important for the exchanger to be able to provide the maximum thermal exchange, therefore it is essential for the inner surfaces to be clean of dirt and incrustations.

Periodically check the difference between the temperature of the supply water and the condensation temperature: if the difference is greater than 8°C–10°C it is advisable to clean the exchanger.

The clearing must be effected:

- with circulation opposite to the usual one
- with a speed at least 1,5 times higher than the nominal one
- with an appropriate product moderately acid (95% water + 5% phosphoric acid)
- after the cleaning rinse with water to inhibit the action of any residual product

### 8.6 Circulating pumps

Check:

- no leaks
- bearing status (anomalies are highlighted by abnormal noise and vibration)
- the terminal protection covers are closed and the cable holders are properly positioned

### 8.7 Insulations

Check the condition of the insulations: if necessary apply glue and and renew the seals.

### 8.8 Water filter

Check that no impurities prevent the correct passage of water.

### 8.9 Flow Switch

- controls the operations
- remove incrustations from the palette

## 8.10 Compressor supply line shut-off valve



A. Supply line shut-off valve



Do not remove the seal  
Remove only if authorized by the manufacturer.  
Please contact the maker for informations.

## 8.11 crankcase heater

Check:

- closure
- Operation

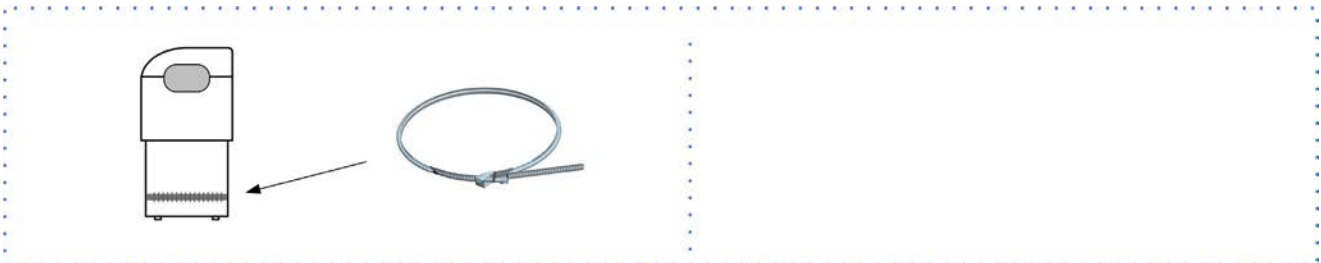

## 8.12 Copeland scroll compressor

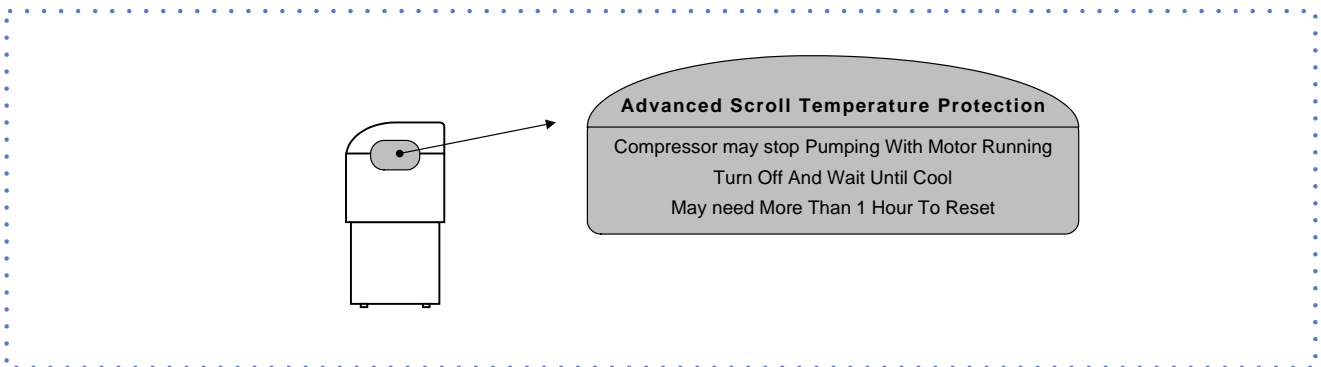

## 8.13 System discharge

1. evacuate the system
2. evacuate the exchanger, use all the present taps
3. use compressed air to blow the exchanger
4. dry completely the exchanger by an hot air jet; for greater safety fill the exchanger with glycoled solution
5. protect the exchanger from the air
6. remove the drain plugs to the pumps



Any anti-freeze liquid contained in the system should not be discharged freely as it is a pollutant.

It must be collected and reused.

Before starting a washing the plant.

Example

- emptying pump

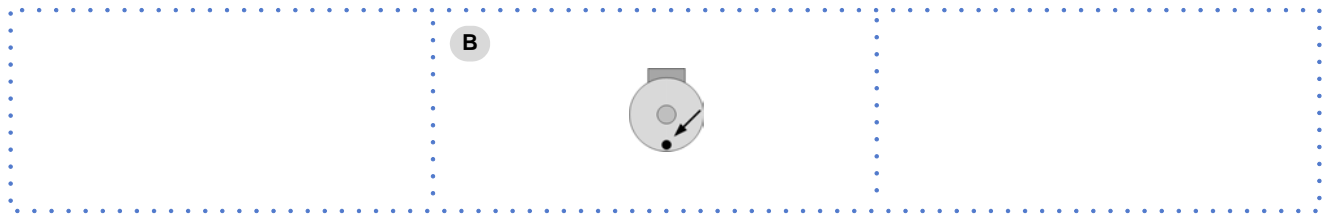

It's recommended that the re-start after the stopping period is performed by a qualified technician, especially after seasonal stops or seasonal switching.

When restarting, refer to what is indicated in the "start-up" section.

Schedule technical assistance in advance to avoid hitches and to guarantee that the system can be used when required.



## 9 Accessories

### 9.1 User side hydronic unit configurations

- 1 standard unit
- 2 VARYFLOW + (cooling side 2 inverter pumps)
- 3 Cooling side hydronic assembly with 1 ON/OFF pump
- 4 Cooling side hydronic assembly with 2 ON/OFF pumps

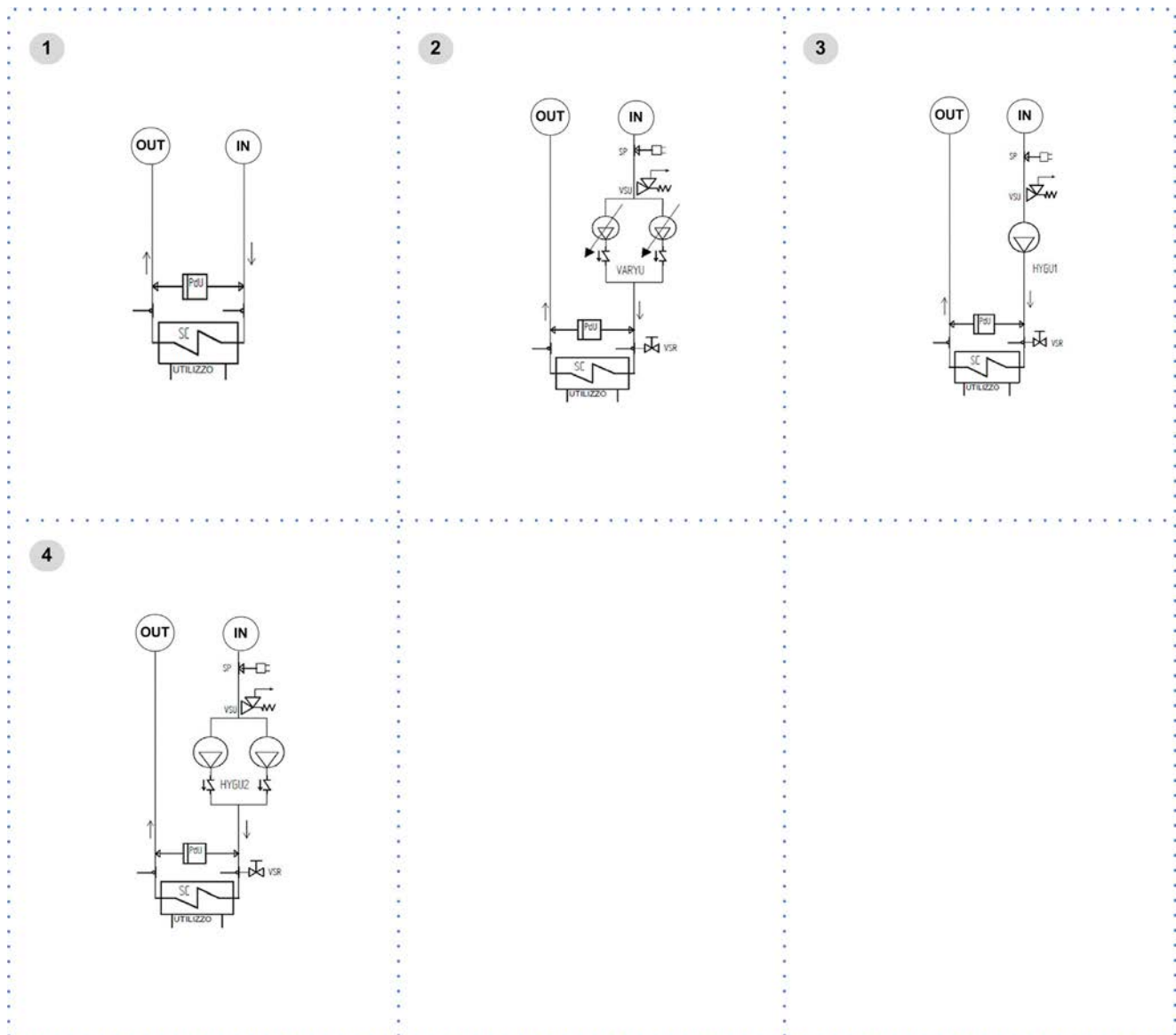

IN user side inlet  
 SP pressure switch of the charged system  
 PDU User side differential pressure switch  
 SC plate exchanger

OUT user side outlet  
 VSU safety valve  
 VSR Drain valve

## 9.2 Source side hydronic assembly configurations

- |   |  |   |   |
|---|--|---|---|
| 1 | standard unit                                    | 4 | Source side hydronic assembly with 2 ON/OFF pumps |
| 2 | VARYFLOW + (heating side 2 inverter pumps)       | 5 | Source side 3-way modulating valve                |
| 3 | Source side hydronic assembly with 1 ON/OFF pump | 6 | Source side 2-way modulating valve                |

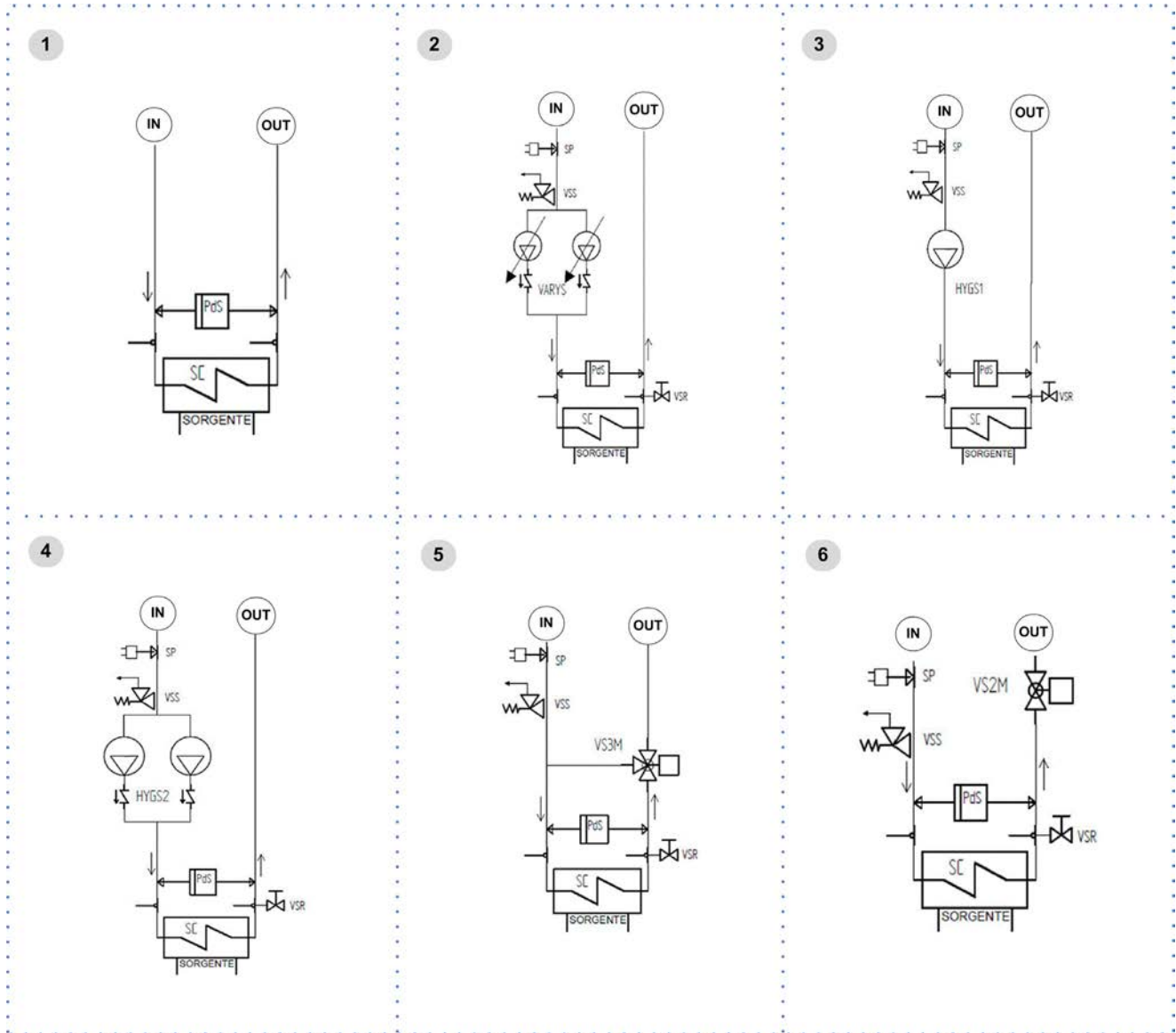

- |     |  |     |               |
|-----|--|-----|---------------|
| IN  | Source inlet                             | OUT | source outlet |
| SP  | pressure switch of the charged system    | VSS | safety valve  |
| PDS | Source side differential pressure switch | VSR | Drain valve   |
| SC  | plate exchanger                          |     |               |

### 9.3 Source side 3-way modulating valve

UNIT : source side

SYSTEM : source side

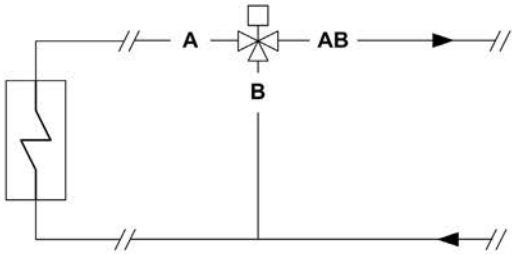

#### Parameters settings

Par.	Description	Value
21	Enable source signal	1
513	Flow control: with valve = 1	1
505	Min source signal (%)	50
506	Max source signal (%)	100

#### Size 10.2 – 40.2

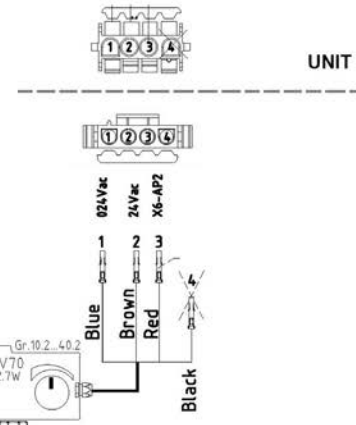
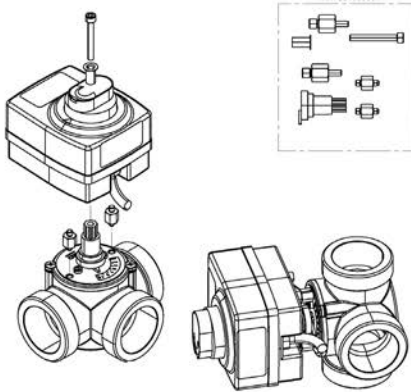

#### Size 43.2 – 120.2

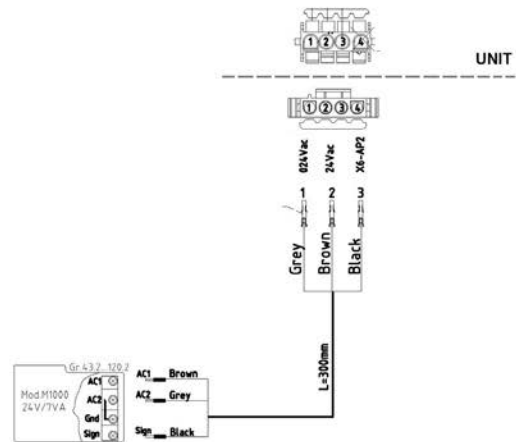
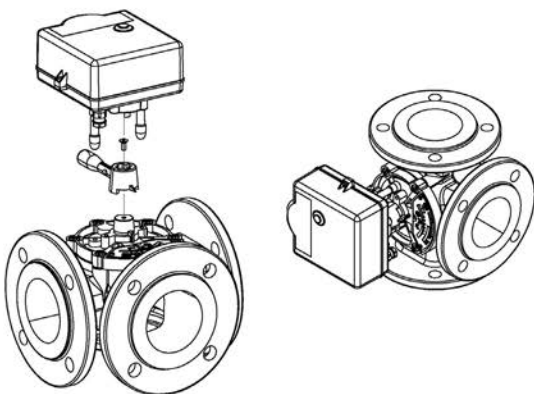

## 9.4 Source side 2-way modulating valve

UNIT : source side

SYSTEM : source side

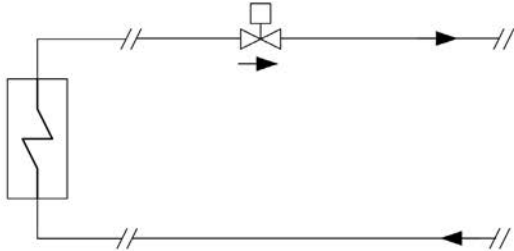

### Parameters settings

Par.	Description	Value
21	Enable source signal	1
513	Flow control: with valve = 1	1
505	Min source signal (%)	50
506	Max source signal (%)	100

### Size 10.2 – 40.2

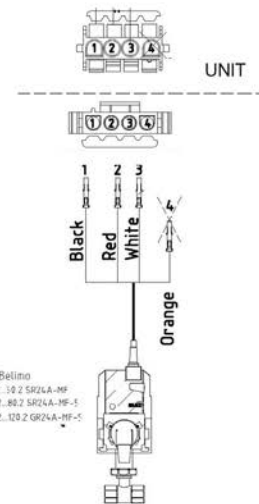
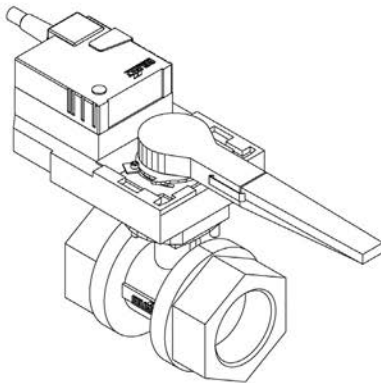

### Size 43.2 – 120.2

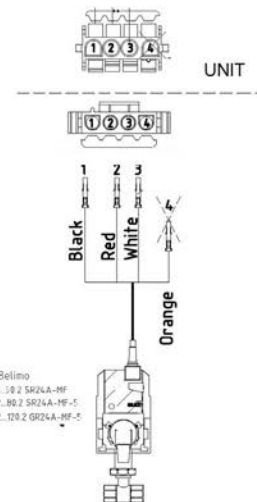
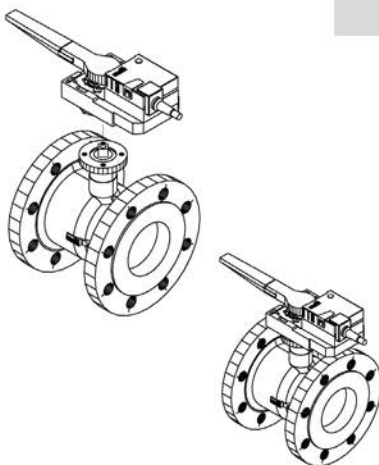

## 9.5 VALVE FOR DOMESTIC HOT WATER

UNIT : user side

SYSTEM : user side

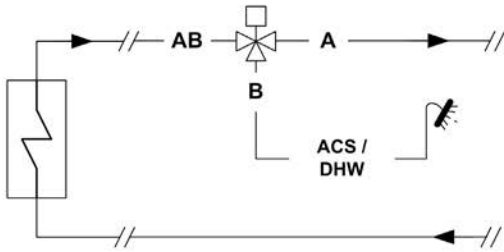

### Parameters settings

Par.	Description	Value
23	Enable domestic hot water!	1
580	Setpoint	

### Size 10.2 – 40.2

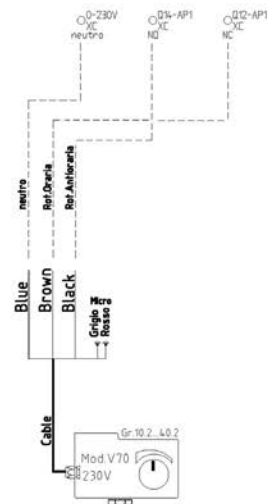
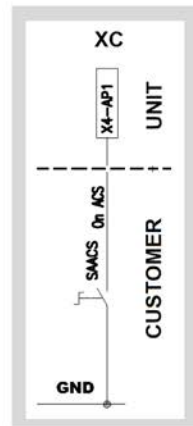
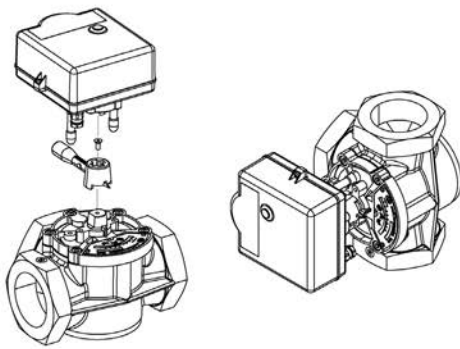

### Size 43.2 – 120.2

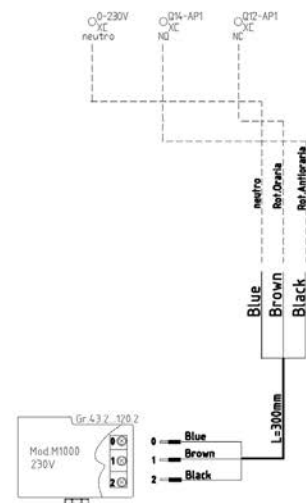
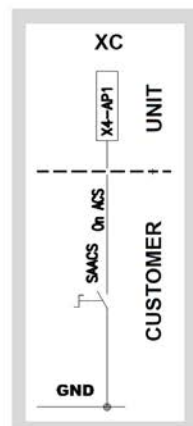
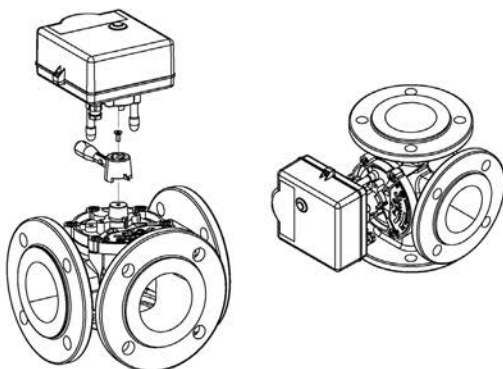

## 9.6 NATURAL COOLING function

Enabling the Natural Cooling functions, the unit is able to independently manage a system for cold production using source water in the event the temperature conditions of the fluid are favorable.

In this case, the source is managed as if it were the first unit available capacity step and can be used to cover the 100% of the cooling load or also, in integration to the compressors, to cover a part of the cold demand by resetting or reducing the compressor power input.

The Natural Cooling installation should include the following additional components (not supplied by Clivet):

1) Natural Cooling water/water exchanger (SCNC in the main scheme): this exchanger shall be suitably dimensioned according to the fluid temperature, user and source side, and according to the pressure drop of the remaining part of the installation and to the unit available static pressure if pumps are not built-in.

2) Two 3-way on/off or equivalent valves (VNCS and VNCU in the main scheme): one on the source circuit and one on the user circuit. Also these have to be suitably dimensioned according to the expected flow rates.

For the correct operation of the Natural Cooling function, the set point control must be set on supply (parameter 436 Tiporeg).

In the installation set up phase it will be necessary to remotely probe on the source input water upstream of the switching valve source side (VNCS).

The unit can be selected with or without hydronic assemblies user and source side: the system must be able to absorb/manage the flow rate/head variations due to the heater change after the Natural Cooling exchanger insertion and exclusion.

The unit control provides an on/off signal to enable the Natural Cooling by switching the valves.

The Natural Cooling is enabled if the two following conditions are satisfied

1) the entering water temperature, source side, must be lower than the cooling set point plus a delta defined by parameter 365 DeltaNC (the value can be positive or negative)  $[T_{ws\_in} < (Set\_cooling + \Delta NC)]$

2) the entering water temperature, user side, must be higher than the entering water temperature, source side, plus a delta defined by parameter 366 IsteresiStopNC (the value can be only positive)  $[T_{ws\_in} < (T_{wu\_in} + IsteresiStopNC)]$

If one of these two conditions is not satisfied the Natural Cooling is disabled.

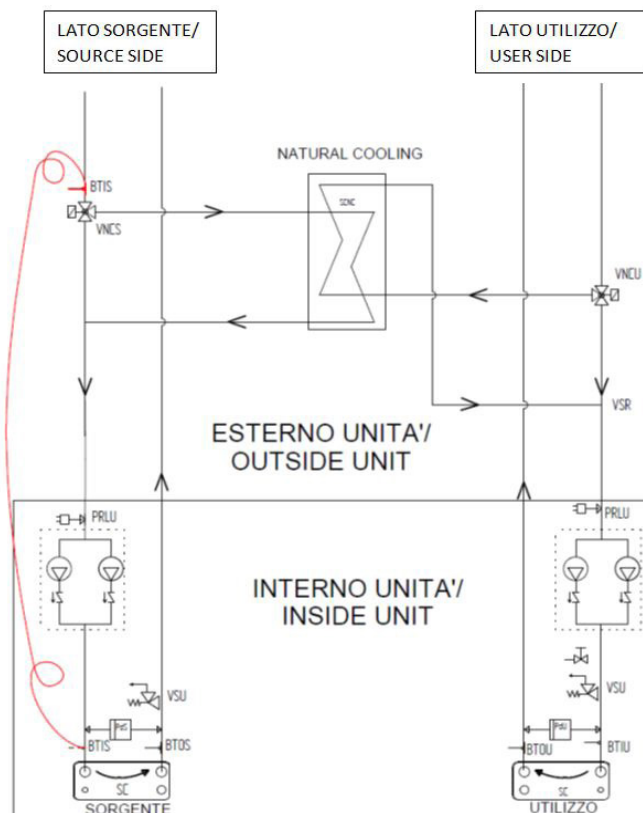

PDU Differential pressure switch, user side  
 PDS Differential pressure switch, source side  
 PRLU Installation load pressure switch adjusted at 0.5 bar  
 SC Plate heat exchanger  
 VSU Safety valve adjusted at 6 bar (only if pumps or valves are present)  
 VSR Exhaust valve  
 BTIS Entering temperature probe, source side (to remotely)

BTOS Leaving temperature probe, source side  
 BTIU Entering temperature probe, user side  
 BTOU Leaving temperature probe, user side  
 VNCS Natural Cooling valve, source side (provided by the Customer)  
 VNCU Natural Cooling valve, user side (provided by the Customer)  
 SCNC Natural Cooling exchanger (provided by the Customer)



## 10 Decommissioning

### 10.1 Disconnecting

Only authorised personnel must disconnect the unit.

Avoid leak or spills into the environment.

Before disconnecting the unit, the following must be recovered, if present:

- refrigerant gas
- anti-freeze solutions in the water circuit

Awaiting dismantling and disposal, the unit can also be stored outdoors, if the electrical, cooling and water circuits of the unit have 100% integrity and are isolated, bad weather and rapid change in temperature will not result in any environmental impact.

### 10.2 Dismantling and disposal

The unit must always be sent to authorised centres for dismantling and disposal.

When dismantling the unit, the fan, the motor and the coil, if operating, may be recovered by the specialist centres for reuse.

All the materials must be recovered or disposed of in compliance with the corresponding national standards in force.

For further information on the decommissioning of the unit, contact the manufacturer.

### 10.3 Directive EC RAEE

The units covered by the legislation in question are marked with the symbol on the side.

With the aim of protecting the environment, all of our units are produced in compliance with Directive EC on waste electrical and electronic equipment (RAEE).

The potential effects on the environment and on human health due to the presence of hazardous substances are shown in the use and maintenance manual in the section on residual risks.

Information in addition to that indicated below, if required, can be obtained from the manufacturer/distributor/importer, who are responsible for the collection/handling of waste originating from equipment covered by EC-RAEE. This information is also available from the retailer who sold this appliance or from the local authorities who handle waste.

Directive EC-RAEE requires disposal and recycling of electrical and electronic equipment as described therein to be handled through appropriate collection, in suitable centres, separate from collection for the disposal of mixed urban waste.

The user must not dispose of the unit at the end of its life cycle as urban waste, it must instead be handed over to appropriate collection centres as set forth by current standards or as instructed by the distributor.



## 11 Residual risks

### General description

In this section the most common situations are indicated, as these cannot be controlled by the manufacturer and could be a source of risk situations for people or things.

#### Danger zone

This is an area in which only an authorised operator may work.

The danger zone is the area inside the unit which is accessible only with the deliberate removal of protections or parts thereof.

#### Handling

The handling operations, if implemented without all of the protection necessary and without due caution, may cause the drop or the tipping of the unit with the consequent damage, even serious, to persons, things or the unit itself.

Handle the unit following the instructions provided in the present manual regarding the packaging and in compliance with the local regulations in force. Should the refrigerant leak please refer to the refrigerant "Safety sheet".

#### Installation

The incorrect installation of the unit could cause water leaks, condensate accumulation, leaking of the refrigerant, electric shock, poor operation or damage to the unit itself.

Check that the installation has been implemented by qualified technical personnel only and that the instructions contained in the present manual and the local regulations in force have been adhered to.

The installation of the unit in a place where even infrequent leaks of inflammable gas and the accumulation of this gas in the area surrounding the area occur could cause explosions or fires.

Carefully check the positioning of the unit.

The installation of the unit in a place unsuited to support its weight and/or guarantee adequate anchorage may result in consequent damage to things, people or the unit itself.

Carefully check the positioning and the anchoring of the unit.

Easy access to the unit by children, unauthorised persons or animals may be the source of accidents, some serious.

Install the unit in areas which are only accessible to authorised person and/or provide protection against intrusion into the danger zone.

#### General risks

Smell of burning, smoke or other signals of serious anomalies may indicate a situation which could cause damage to people, things or the unit itself.

Electrically isolate the unit (yellow-red isolator).

Contact the authorised service centre to identify and resolve the problem at the source of the anomaly.

Accidental contact with exchange batteries, compressors, air delivery tubes or other components may cause injuries and/or burns.

Always wear suitable clothing including protective gloves to work inside the danger zone.

Maintenance and repair operations carried out by non-qualified personnel may cause damage to persons, things or the unit itself.

Always contact the qualified assistance centre.

Failing to close the unit panels or failure to check the correct tightening of all of the panelling fixings screws may cause damage to persons, things or the unit itself.

Periodically check that all of the panels are correctly closed and fixed.

If there is a fire the temperature of the refrigerant could reach values that increase the pressure to beyond the safety valve with the consequent possible projection of the refrigerant itself or explosion of the circuit parts that remain isolated by the closure of the tap.

Do not remain in the vicinity of the safety valve and never leave the refrigeration system taps closed.

### Electric parts

An incomplete attachment line to the electric network or with incorrectly sized cables and/or unsuitable protective devices can cause electric shocks, intoxication, damage to the unit or fires.

Carry out all of the work on the electric system referring to the electric layout and the present manual ensuring the use of a system thereto dedicated.

An incorrect fixing of the electric components cover may lead to the entry of dust, water etc inside and may consequently electric shocks, damage to the unit or fires.

Always fix the unit over properly.

When the metallic mass of the unit is under voltage and is not correctly connected to the earthing system it may be as source of electric shock and electrocution.

Always pay particular attention to the implementation of the earthing system connections.

Contact with parts under voltage accessible inside the unit after the removal of the guards can cause electric shocks, burns and electrocution.

Open and padlock the general isolator prior to removing the guards and signal work in progress with the appropriate sign.

Contact with parts that could be under voltage due to the start up of the unit may cause electric shocks, burns and electrocution.

When voltage is necessary for the circuit open the isolator on the attachment line of the unit itself, padlock it and display the appropriate warning sign.

#### Moving parts

Contact with the transmissions or with the fan aspiration can cause injuries.

Prior to entering the inside of the unit open the isolator situated on the connection line of the unit itself, padlock and display the appropriate warning sign.

Contact with the fans can cause injury.

Prior to removing the protective grill or the fans, open the isolator on the attachment line of the unit itself, padlock it and display the appropriate warning sign.

#### Refrigerant

The intervention of the safety valve and the consequent expulsion of the gas refrigerant may cause injuries and intoxication.

Always wear suitable clothing including protective gloves and eyeglasses for operations inside the danger zone.

Should the refrigerant leak please refer to the refrigerant "Safety sheet".

Contact between open flames or heat sources with the refrigerant or the heating of the gas circuit under pressure (e.g. during welding operations) may cause explosions or fires.

Do not place any heat source inside the danger zone.

The maintenance or repair interventions which include welding must be carried out with the system off.

#### Hydraulic parts

Defects in tubing, the attachments or the removal parts may cause a leak or water projection with the consequent damages to people, things or shortcircuit the unit.



# General technical data

## Groundwater version

Size		10.2	12.2	14.2	16.2	19.2	22.2	27.2	30.2	35.2	40.2	43.2	45.2	50.2	55.2	60.2	70.2	80.2	90.2	100.2	120.2	
<b>Radiant panels</b>																						
<b>Heating</b>																						
Heating capacity (EN14511:2013)	1	35,0	41,1	49,1	58,0	68,8	81,4	94,8	107	120	141	152	162	183	200	223	258	286	321	351	421	
Total power input (EN14511:2013)	2	6,58	7,77	9,47	11,1	13,1	16,2	17,7	20,6	23,6	27,0	29,9	32,8	34,7	38,5	43,7	49,1	55,7	63,1	68,9	82,7	
COP (EN 14511:2013)	3	5,32	5,29	5,18	5,23	5,27	5,02	5,36	5,19	5,10	5,21	5,10	4,93	5,28	5,21	5,11	5,25	5,13	5,10	5,10	5,10	
ErP Space Heating Energy Class - AVERAGE Climate - W35	12	A++	A++	A++	A++	A++	-	-	-	-	-	-	-	-	-	-	-	-	-	-	-	
<b>Cooling</b>																						
Cooling capacity (EN14511:2013)	6	kW	40,3	47,1	56,1	66,6	79,1	92,6	108	121	135	162	179	189	212	229	155	295	325	360	393	468
Total power input (EN14511:2013)	2	kW	6,59	8,15	10,1	11,7	13,7	16,7	18,5	21,4	25,2	28,5	32,3	34,2	37,2	40,9	46,7	53,6	61,6	66,2	72,9	86,9
EER (EN 14511:2013)	7		6,12	5,78	5,58	5,68	5,76	5,55	5,84	5,66	5,35	5,70	5,52	5,52	5,69	5,60	5,46	5,51	5,27	5,43	5,39	5,38
<b>Terminal units</b>																						
<b>Heating</b>																						
Heating capacity (EN14511:2013)	4		34,4	40,4	48,0	56,8	67,0	79,5	93,8	107	119	139	151	163	178	195	218	252	280	314	343	408
Total power input (EN14511:2013)	2		8,18	9,65	11,6	13,4	15,7	19,1	21,4	24,7	28,3	32,3	36,0	38,4	41,3	45,7	51,9	58,0	65,5	75,3	82,5	100
COP (EN 14511:2013)	3		4,20	4,19	4,15	4,25	4,27	4,15	4,38	4,32	4,21	4,30	4,18	4,24	4,32	4,27	4,20	4,34	4,27	4,17	4,16	4,07
<b>Cooling</b>																						
Cooling capacity (EN14511:2013)	8		29,2	34,4	40,7	48,4	57,7	67,6	82,0	91,8	102	120	131	138	155	168	187	217	240	265	292	347
Total power input (EN14511:2013)	2		6,40	7,50	9,10	10,6	12,5	15,4	17,5	20,5	23,6	26,8	29,9	31,7	34,2	37,7	42,6	48,2	54,5	61,4	67,8	81,7
EER (EN 14511:2013)	7		4,57	4,58	4,47	4,56	4,62	4,38	4,68	4,49	4,32	4,47	4,38	4,37	4,52	4,46	4,38	4,50	4,40	4,31	4,31	4,25
ESEER	9		5,99	5,77	5,39	5,27	5,44	5,25	5,87	5,66	5,71	5,69	5,49	5,74	5,65	5,50	5,41	5,54	5,24	5,28	5,34	5,28
<b>Radiators</b>																						
<b>Heating</b>																						
Heating capacity (EN14511:2013)	5		31,7	37,6	44,6	52,4	61,6	73,2	88,3	99,4	112	132	145	154	166	181	202	233	259	291	314	375
Total power input (EN14511:2013)	2		10,3	12,2	14,4	16,5	19,4	23,0	26,3	29,8	34,7	39,4	44,3	47,0	50,7	55,8	63,3	70,2	78,6	92,5	103	127
COP (EN 14511:2013)	3		3,08	3,09	3,10	3,17	3,18	3,18	3,35	3,33	3,24	3,35	3,26	3,27	3,27	3,24	3,19	3,32	3,29	3,15	3,05	2,96
ErP Space Heating Energy Class - AVERAGE Climate - W55	12		A++	A++	A++	A++	A++	-	-	-	-	-	-	-	-	-	-	-	-	-	-	-
<b>Compressor</b>																						
Type of compressors			Scroll	Scroll	Scroll	Scroll	Scroll	Scroll	Scroll	Scroll	Scroll	Scroll	Scroll	Scroll	Scroll	Scroll	Scroll	Scroll	Scroll	Scroll	Scroll	Scroll
No. of compressors		No	2	2	2	2	2	2	2	2	2	2	2	2	2	2	2	2	2	2	2	2
Std Capacity control steps		No	3	3	2	3	3	3	3	2	3	3	3	3	3	3	2	3	2	3	3	2
Oil charge		l	3,00	3,00	3,00	6,00	6,00	6,00	7,00	7,00	8,00	10,0	12,0	11,0	11,0	13,0	13,0	13,0	13,0	13,0	13,0	13,0
Refrigerant charge		kg	4,7	5,2	6,0	8,2	9,1	11	12	14	17	20	22	23	24	26	29	33	34	37	38	41
Refrigeration circuits		No	1	1	1	1	1	1	1	1	1	1	1	1	1	1	1	1	1	1	1	1
<b>Internal exchanger</b>																						
Type of internal exchanger	10		PHE	PHE	PHE	PHE	PHE	PHE	PHE	PHE	PHE	PHE	PHE	PHE	PHE	PHE	PHE	PHE	PHE	PHE	PHE	PHE
No. of internal exchangers		No	1	1	1	1	1	1	1	1	1	1	1	1	1	1	1	1	1	1	1	1
Water fl w-rate (User Side)	8	l/s	1,40	1,70	2,00	2,30	2,80	3,30	3,90	4,40	4,90	5,70	6,30	6,60	7,40	8,10	9,00	10,4	11,5	12,7	14,4	16,7
<b>External exchanger</b>																						
Type of external exchanger	10		PHE	PHE	PHE	PHE	PHE	PHE	PHE	PHE	PHE	PHE	PHE	PHE	PHE	PHE	PHE	PHE	PHE	PHE	PHE	PHE
No. of external exchangers		No	1	1	1	1	1	1	1	1	1	1	1	1	1	1	1	1	1	1	1	1
Water fl w rate (Source Side)	8	l/s	1,70	2,00	2,40	2,80	3,30	4,00	4,70	5,40	6,00	7,00	7,70	8,10	9,00	9,80	10,9	12,6	14,0	15,6	17,6	20,5
<b>Connections</b>																						
Water fittings ( standard units)			1 1/4	1 1/4	1 1/4	1 1/4	1 1/4	1 1/4	2 1/2	2 1/2	2 1/2	2 1/2	2 1/2	2 1/2	2 1/2	2 1/2	2 1/2	2 1/2	2 1/2	2 1/2	3'	3'
Water fittings ( arge units)			2'	2'	2'	2'	2'	2'	3'	3'	3'	3'	3'	3'	3'	3'	3'	3'	3'	3'	4'	4'
<b>Water circuit</b>																						
Maximum water side pressure	11	MPa	1.0	1.0	1.0	1.0	1.0	1.0	1.0	1.0	1.0	1.0	1.0	1.0	1.0	1.0	1.0	1.0	1.0	1.0	1.0	1.0
Min. installation water contents	13	l	236	227	357	380	364	334	578	795	757	758	960	716	938	1239	1622	1600	2082	1379	1924	3023
<b>Power supply</b>																						
Standard power supply		V	400/3/50	400/3/50	400/3/50	400/3/50	400/3/50	400/3/50	400/3/50	400/3/50	400/3/50	400/3/50	400/3/50	400/3/50	400/3/50	400/3/50	400/3/50	400/3/50	400/3/50	400/3/50	400/3/50	400/3/50

The Product is compliant with the ErP (Energy Related Products) European Directive. It includes the Commission delegated Regulation (EU) No 811/2013 (rated heat output ≤ 70 kW at specified reference conditions) and the Commission delegated Regulation (EU) No 813/2013 (rated heat output ≤ 400 kW at specified reference conditions)

- Data referred to the following conditions: Internal exchanger water 30/35 °C. External exchanger water 10/7 °C. Performance data calculated with reference to EN14511:2013
- The total power draw is calculated by adding the compressor's power draw + the draw required to overcome the internal service and source side pressure drops + the control circuit power draw
- COP (EN 14511:2013) heating performance coefficient. Ratio between delivered heating capacity and power input in compliance with EN 14511:2013
- Data referred to the following conditions: Internal exchanger water 40/45 °C. External exchanger water 10/7 °C. Performance data calculated with reference to EN14511:2013
- Data referred to the following conditions: Internal exchanger water 50/55 °C. External exchanger water 10/7 °C. Performance data calculated with reference to EN14511:2013

- Data referred to the following conditions: Internal exchanger water 23/18 °C. External exchanger water 30/35 °C. Performance data calculated with reference to EN14511:2013
- EER (EN 14511:2013) cooling performance coefficient. Ratio between delivered cooling capacity and power input in compliance with EN 14511:2013
- Data referred to the following conditions: Internal exchanger water 12/7 °C. External exchanger water 30/35 °C. Performance data calculated with reference to EN14511:2013
- ESEER calculated per EUROVENT, for installations with terminal units with water produced at 7 °C and constant source side fl w
- PHE = plate exchanger
- Conditions for the circuit on the utility side and the circuit on the source side. In configurations with hydronic units, the maximum pressure on the water side is 600 kPa.
- Seasonal Space Heating Energy Efficiency Class according to Commission delegated Regulation (EU) No 811/2013. W = Water outlet temperature (°C)
- The minimum system water content calculated value does not consider the internal exchanger water content. With applications or low medium requested loads, the minimum installation water volume is obtained doubling the indicated value

# General technical data

## Geothermic version

Size		10.2	12.2	14.2	16.2	19.2	22.2	27.2	30.2	35.2	40.2	43.2	45.2	50.2	55.2	60.2	70.2	80.2	90.2	100.2	120.2
<b>Radiant panels</b>																					
<b>Heating</b>																					
Heating capacity (EN14511:2013)	1	27,8	32,6	37,9	45,3	54,3	63,4	75,3	85,1	95,7	111	121	129	141	156	173	196	218	247	266	312
Total power input (EN14511:2013)	2	6,47	7,55	8,83	10,5	12,4	14,8	16,8	19,4	22,2	25,6	28,2	30,0	32,5	35,9	40,3	45,3	50,7	59,2	64,3	78,4
COP (EN 14511:2013)	3	4,30	4,32	4,30	4,31	4,37	4,30	4,49	4,39	4,31	4,33	4,30	4,31	4,34	4,33	4,30	4,34	4,31	4,17	4,14	3,98
<b>Cooling</b>																					
Cooling capacity (EN14511:2013)	6	37,8	43,7	50,8	61,3	76,4	87,9	106	119	135	156	172	183	202	221	247	281	310	357	399	467
Total power input (EN14511:2013)	2	7,31	9,08	11,2	12,8	14,3	17,5	18,3	21,1	25,1	28,6	32,1	33,4	37,3	40,7	46,2	53,4	61,4	68,4	75,8	91,0
EER (EN 14511:2013)	7	5,17	4,82	4,55	4,78	5,34	5,02	5,79	5,63	5,40	5,45	5,37	5,49	5,42	5,42	5,33	5,26	5,04	5,22	5,26	5,12
<b>Terminal units</b>																					
<b>Heating</b>																					
Heating capacity (EN14511:2013)	4	27,4	32,2	37,5	44,7	53,1	62,3	73,5	83,0	93,4	108	119	127	138	153	170	194	214	244	263	309
Total power input (EN14511:2013)	2	8,30	9,60	11,0	13,1	15,4	18,3	20,6	23,4	27,1	31,0	34,4	36,6	39,6	43,9	49,7	55,2	61,6	72,6	78,6	96,4
COP (EN 14511:2013)	3	3,29	3,36	3,40	3,41	3,46	3,40	3,57	3,54	3,45	3,50	3,44	3,47	3,49	3,48	3,42	3,51	3,48	3,36	3,34	3,21
<b>Cooling</b>																					
Cooling capacity (EN14511:2013)	8 kW	28,5	33,2	38,2	45,8	57,0	65,6	80,8	90,9	103	119	130	142	153	167	187	213	237	264	296	343
Total power input (EN14511:2013)	2 kW	7,00	8,30	10,1	11,6	13,0	16,1	17,5	20,3	23,5	26,9	29,8	31,4	34,5	37,6	42,6	48,5	55,0	62,8	69,4	84,2
EER (EN 14511:2013)	7	4,06	3,98	3,78	3,96	4,39	4,09	4,63	4,48	4,36	4,41	4,37	4,52	4,44	4,45	4,39	4,39	4,33	4,22	4,27	4,08
<b>Radiators</b>																					
<b>Heating</b>																					
Heating capacity (EN14511:2013)	5 kW	25,7	30,5	35,3	42,0	49,6	58,7	68,3	77,9	87,7	101	111	120	130	144	162	183	202	228	245	288
Total power input (EN14511:2013)	2 kW	10,5	12,2	14,0	16,5	19,2	22,5	25,8	29,1	33,7	38,2	42,7	45,4	49,3	54,3	61,7	67,9	75,1	90,5	98,0	122
COP (EN 14511:2013)	3	2,44	2,51	2,52	2,55	2,58	2,61	2,64	2,68	2,60	2,65	2,61	2,65	2,65	2,65	2,63	2,70	2,70	2,51	2,50	2,36
<b>Compressor</b>																					
Type of compressors		Scroll	Scroll	Scroll	Scroll	Scroll	Scroll	Scroll	Scroll	Scroll	Scroll	Scroll	Scroll	Scroll	Scroll	Scroll	Scroll	Scroll	Scroll	Scroll	Scroll
No. of compressors	No	2	2	2	2	2	2	2	2	2	2	2	2	2	2	2	2	2	2	2	2
Std Capacity control steps	No	3	3	2	3	3	3	3	2	3	3	3	3	3	3	2	3	2	3	3	2
Oil charge	l	3,00	3,00	3,00	6,00	6,00	6,00	7,00	7,00	8,00	10,0	12,0	11,0	11,0	13,0	13,0	13,0	13,0	13,0	13,0	13,0
Refrigerant charge	kg	4,7	5,2	6,0	8,2	9,1	11	12	14	17	20	22	23	24	26	29	33	34	37	38	41
Refrigeration circuits	No	1	1	1	1	1	1	1	1	1	1	1	1	1	1	1	1	1	1	1	1
<b>Internal exchanger</b>																					
Type of internal exchanger	9	PHE	PHE	PHE	PHE	PHE	PHE	PHE	PHE	PHE	PHE	PHE	PHE	PHE	PHE	PHE	PHE	PHE	PHE	PHE	PHE
No. of internal exchangers	No	1	1	1	1	1	1	1	1	1	1	1	1	1	1	1	1	1	1	1	1
Water fl w-rate (User Side)	8 l/s	1,40	1,60	1,80	2,20	2,70	3,20	3,90	4,40	5,10	5,70	6,30	6,80	7,50	8,30	9,00	10,2	11,4	12,6	14,2	16,5
<b>External exchanger</b>																					
Type of external exchanger	9	PHE	PHE	PHE	PHE	PHE	PHE	PHE	PHE	PHE	PHE	PHE	PHE	PHE	PHE	PHE	PHE	PHE	PHE	PHE	PHE
No. of external exchanger	No	1	1	1	1	1	1	1	1	1	1	1	1	1	1	1	1	1	1	1	1
Water fl w rate (Source Side)	8 l/s	1,80	2,10	2,50	2,90	3,60	4,10	5,0	5,7	6,4	7,4	8,2	8,9	9,6	10,5	11,7	13,4	14,9	16,6	18,7	21,8
<b>Connections</b>																					
Water fittings ( tandard units)		1'1/4	1'1/4	1'1/4	1'1/4	1'1/4	1'1/4	2'1/2	2'1/2	2'1/2	2'1/2	2'1/2	2'1/2	2'1/2	2'1/2	2'1/2	2'1/2	2'1/2	2'1/2	3'	3'
Water fittings ( arge units)		2'	2'	2'	2'	2'	2'	3'	3'	3'	3'	3'	3'	3'	3'	3'	3'	3'	3'	4'	4'
<b>Power supply</b>																					
Standard power supply	V	400/3/50	400/3/50	400/3/50	400/3/50	400/3/50	400/3/50	400/3/50	400/3/50	400/3/50	400/3/50	400/3/50	400/3/50	400/3/50	400/3/50	400/3/50	400/3/50	400/3/50	400/3/50	400/3/50	400/3/50

- Data referred to the following conditions: Internal exchanger water 30/35 °C. External exchanger water 0/-3 °C. Operation with 30% source side mixture of water and propylene glycol. Performance data calculated with reference to EN14511:2013
- The total power draw is calculated by adding the compressor's power draw + the draw required to overcome the internal service and source side pressure drops + the control circuit power draw
- COP (EN 14511:2013) heating performance coefficient. Ratio between delivered heating capacity and power input in compliance with EN 14511:2013
- Data referred to the following conditions: Internal exchanger water 40/45 °C. External exchanger water 0/-3 °C. Operation with 30% source side mixture of water and propylene glycol. Performance data calculated with reference to EN14511:2013
- Data referred to the following conditions: Internal exchanger water 50/55 °C. External exchanger water 0/-3 °C. Operation with 30% source side mixture of water and propylene glycol. Performance data calculated with reference to EN14511:2013
- Data referred to the following conditions: Internal exchanger water 23/18 °C. External exchanger water 30/35 °C. Operation with 30% source side mixture of water and propylene glycol. Performance data calculated with reference to EN14511:2013
- EER (EN 14511:2013) cooling performance coefficient. Ratio between delivered cooling capacity and power input in compliance with EN 14511:2013
- Data referred to the following conditions: Internal exchanger water 12/7 °C. External exchanger water 30/35 °C. Operation with 30% source side mixture of water and propylene glycol. Performance data calculated with reference to EN14511:2013
- PHE = plate exchanger

## Sound levels

Size	Sound power level (dB)								Sound power level	Sound pressure level
	Octave band (Hz)									
	63	125	250	500	1000	2000	4000	8000	dB(A)	dB(A)
10.2	78	70	62	52	52	43	41	40	60	44
12.2	78	69	62	56	52	44	43	38	60	44
14.2	78	67	61	57	54	46	44	39	60	45
16.2	78	71	66	63	53	49	46	41	64	49
19.2	78	73	67	63	55	51	47	42	65	49
22.2	78	73	65	62	55	52	47	42	64	49
27.2	78	73	66	62	56	54	49	44	64	49
30.2	78	74	63	60	56	54	48	44	64	49
35.2	81	83	80	67	61	61	52	45	74	58
40.2	81	79	80	67	65	63	55	50	74	58
43.2	81	83	83	69	66	65	56	49	77	60
45.2	81	78	80	69	66	62	55	48	74	58
50.2	81	83	83	70	67	64	56	47	77	60
55.2	81	80	83	70	68	65	57	50	77	60
60.2	81	80	83	71	69	65	57	50	77	61
70.2	82	80	85	73	72	68	60	51	79	63
80.2	82	80	85	73	74	70	61	52	80	63
90.2	83	81	86	74	75	71	62	53	81	64
100.2	83	81	86	74	75	71	62	53	81	64
120.2	84	82	87	75	76	72	63	54	82	65

Sound levels refer to units with full load under nominal test conditions.

The sound pressure level refers to a distance of 1 meter from the outer surface of the unit operating in open field .

Noise levels are determined using the tensiometric method (UNI EN ISO 9614-2)

Data referred to the following conditions:

Entering / leaving exchanger water temperature user side 12/7°C

Entering / leaving exchanger water temperature source side 30/35°C

## Admissible water flow rates

Min. (Qmin) and max. (Qmax) water flow rates admissible for the correct unit operation.

SIZE			10.2	12.2	14.2	16.2	19.2	22.2	27.2	30.2	35.2	40.2	43.2	45.2	50.2	55.2	60.2	70.2	80.2	90.2	100.2	120.2
User side	Qmin	[l/s]	0,8	0,8	0,8	1,0	1,1	1,1	1,8	1,8	1,8	2,4	2,4	2,4	2,9	2,9	2,9	3,8	3,8	5,3	9,5	10,5
	Qmax	[l/s]	4,2	4,2	4,3	4,8	4,9	5,1	8,8	8,8	9,3	11,4	11,9	12,2	14,4	15	15,4	18,3	19,0	23,5	28,0	29,0
Source side	Qmin	[l/s]	0,8	0,8	0,8	1,0	1,1	1,1	2,2	2,2	2,2	2,9	2,9	2,9	3,6	3,6	3,6	4,3	4,3	5,3	9,5	10,5
	Qmax	[l/s]	4,2	4,2	4,3	4,8	4,9	5,1	11	11,5	11,5	14,4	14,7	15	17,7	18,0	18,5	21,3	21,7	23,0	28,0	30,0

## Overload and control device calibrations

		Intervention	Reset	Value
High pressure switch (gas side)	kPa	4050	3300	-
Low pressure switch (gas side)	kPa	450	600	-
Low pressure switch (gas side) (GEO)	bar	200	350	-
Antifreeze protection	°C	4	6,0	-
high pressure safety valve (gas side)	kPa	-	-	4500
Low pressure safety valve (gas side)	kPa	-	-	3000
Max no. of compressor starts per hour (gas side)	No	-	-	10
Differential pressure switch (water side)	[kPa]	3	5	-
Max. pressure without hydronic assembly (water side)	[kPa]	-	-	1000
Max. pressure with hydronic assembly (water side)	[kPa]	-	-	600
Safety valve calibration (water side) (1)	[kPa]	-	-	600

(1) Available only with hydronic assembly option

# Operating Range (Cooling)

Size 10.2 - 12.2 - 14.2

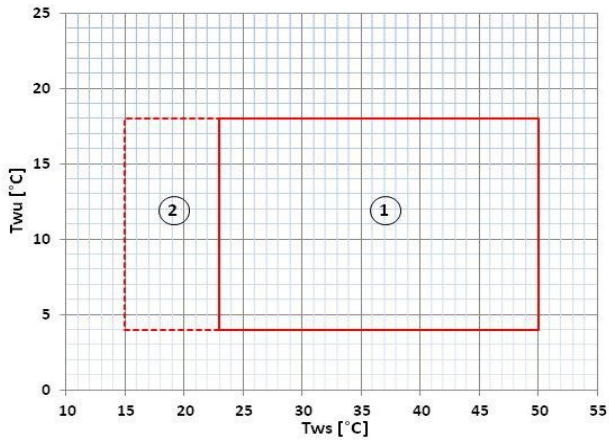

Size 16.2

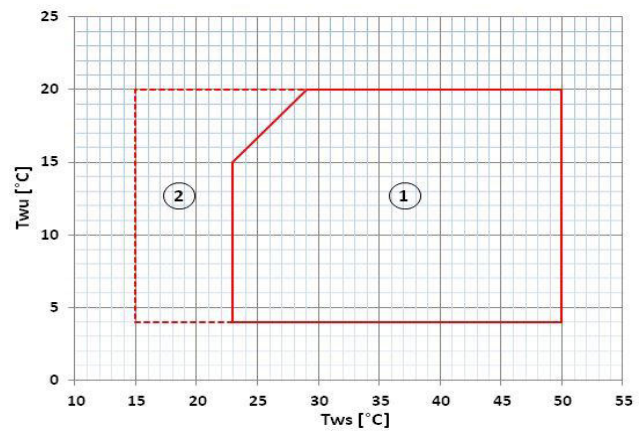

Size 19.2-22.2-27.2-30.2-35.2-40.2-45.2

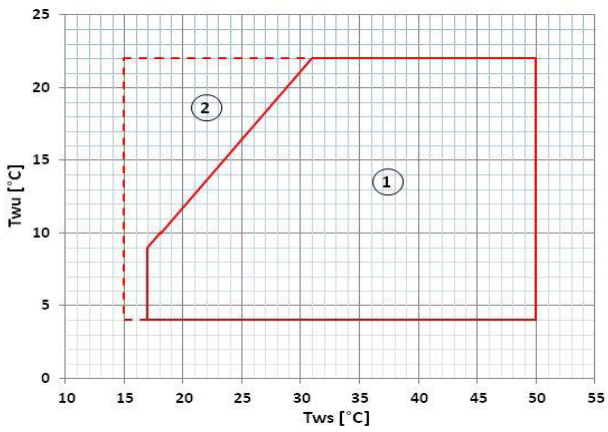

Sizes 43.2-50.2-55.2-60.2-70.2-80.2-90.2-100.2-120.2

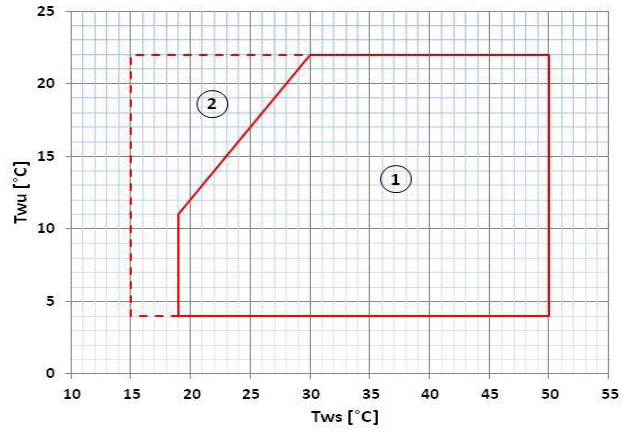

Twu [°C] = Leaving water temperature user side  
 Tws [°C] = Leaving water temperature source side  
 The limits refer to  $\Delta T=5^{\circ}\text{C}$  on both the user and source sides

1. Normal operating range
2. Operating range with modulating valve or inverter pump on source side in regulation mode (optional configurations)

# Operating Range (Heating) - Groundwater

Size 10.2 - 12.2 - 14.2

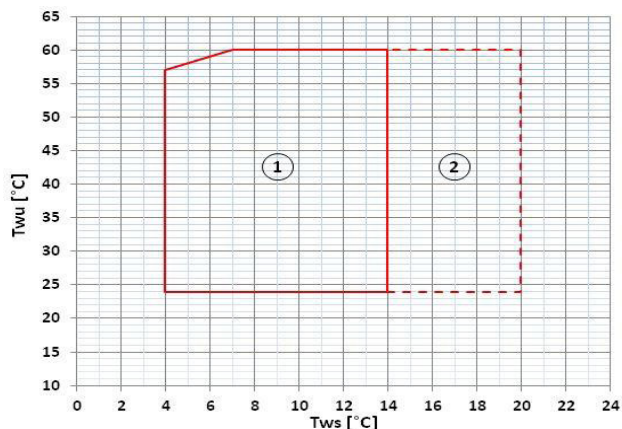

Size 16.2

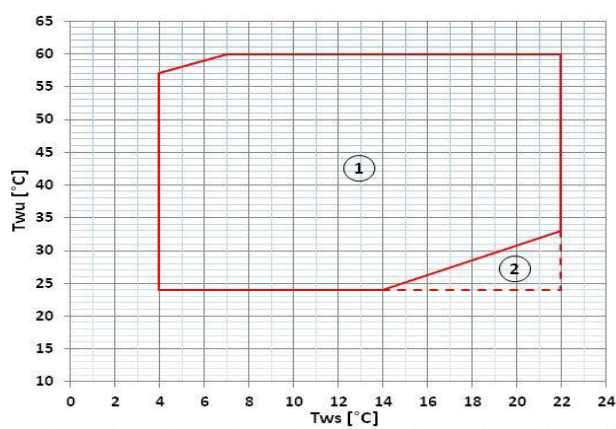

Size 19.2-22.2-27.2-30.2-35.2-40.2-45.2

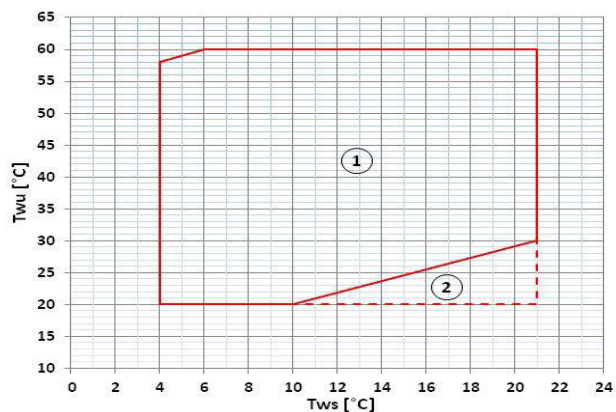

Sizes 43.2-50.2-55.2-60.2-70.2-80.2-90.2-100.2-120.2

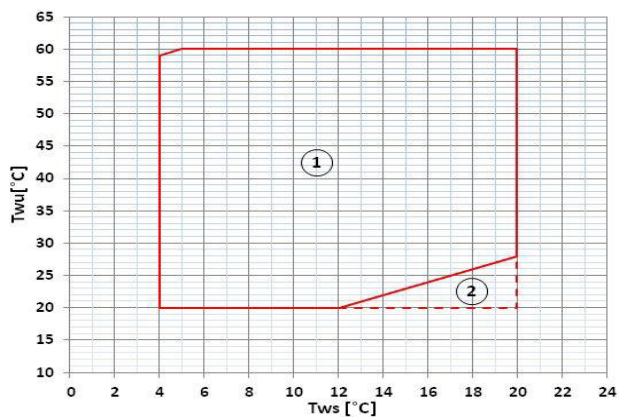

$T_{wu}$  [°C] = Leaving water temperature user side  
 $T_{ws}$  [°C] = Leaving water temperature source side  
 The limits refer to  $\Delta T=5$  °C on both the user and source sides

1. Normal operating range
2. Operating range with modulating valve or inverter pump on source side in regulation mode (optional configurations)



# Operating Range (Heating) - Geothermal

Size 10.2 - 12.2 - 14.2

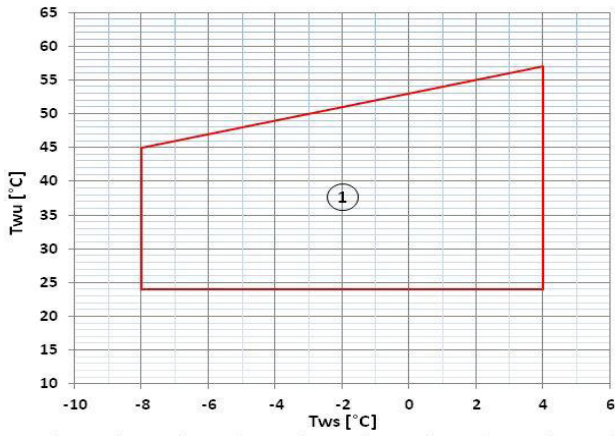

Size 16.2

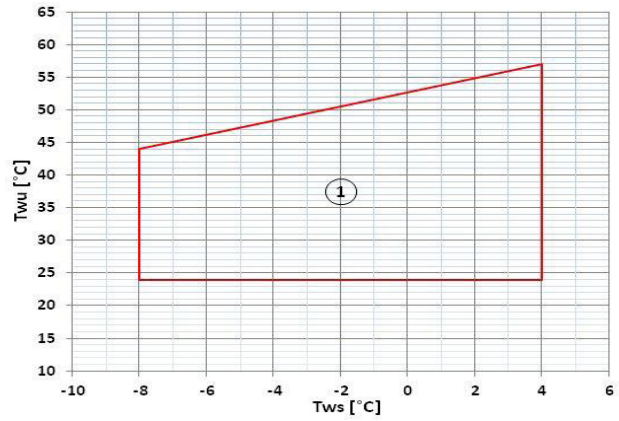

Size 19.2-22.2-27.2-30.2-35.2-40.2-45.2

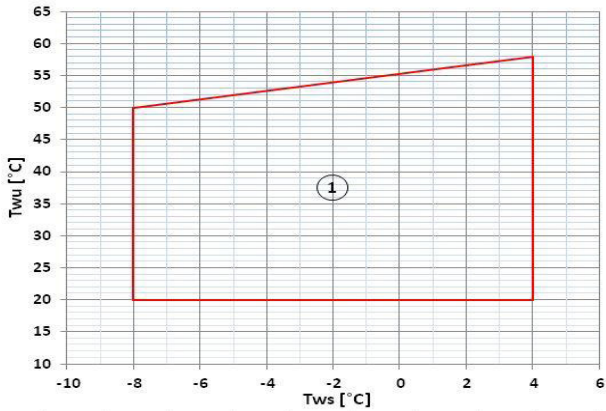

Sizes 43.2-50.2-55.2-60.2-70.2-80.2-90.2-100.2-120.2

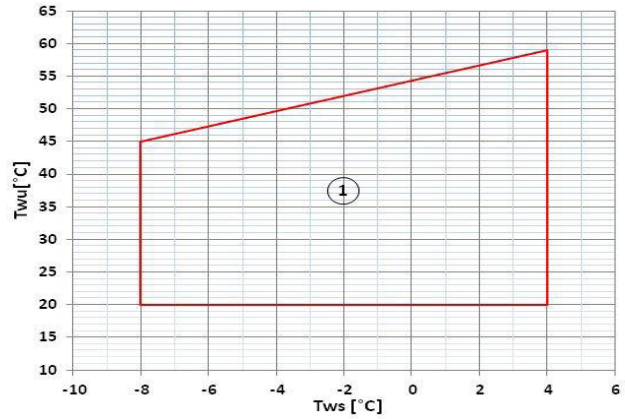

Twu [°C] = Leaving water temperature user side  
 TwS [°C] = Leaving water temperature source side  
 The limits refer to  $\Delta T = 5^\circ\text{C}$  on both the user and source sides

1. Operating range where it is obligatory the use of water and glycol mixture depending on the outlet water temperature from the heat exchanger source side

# Dimensional - Standard version without hydronic unit

## Size 10.2 - 22.2

DAA8U10\_2\_22 2 STD REV01

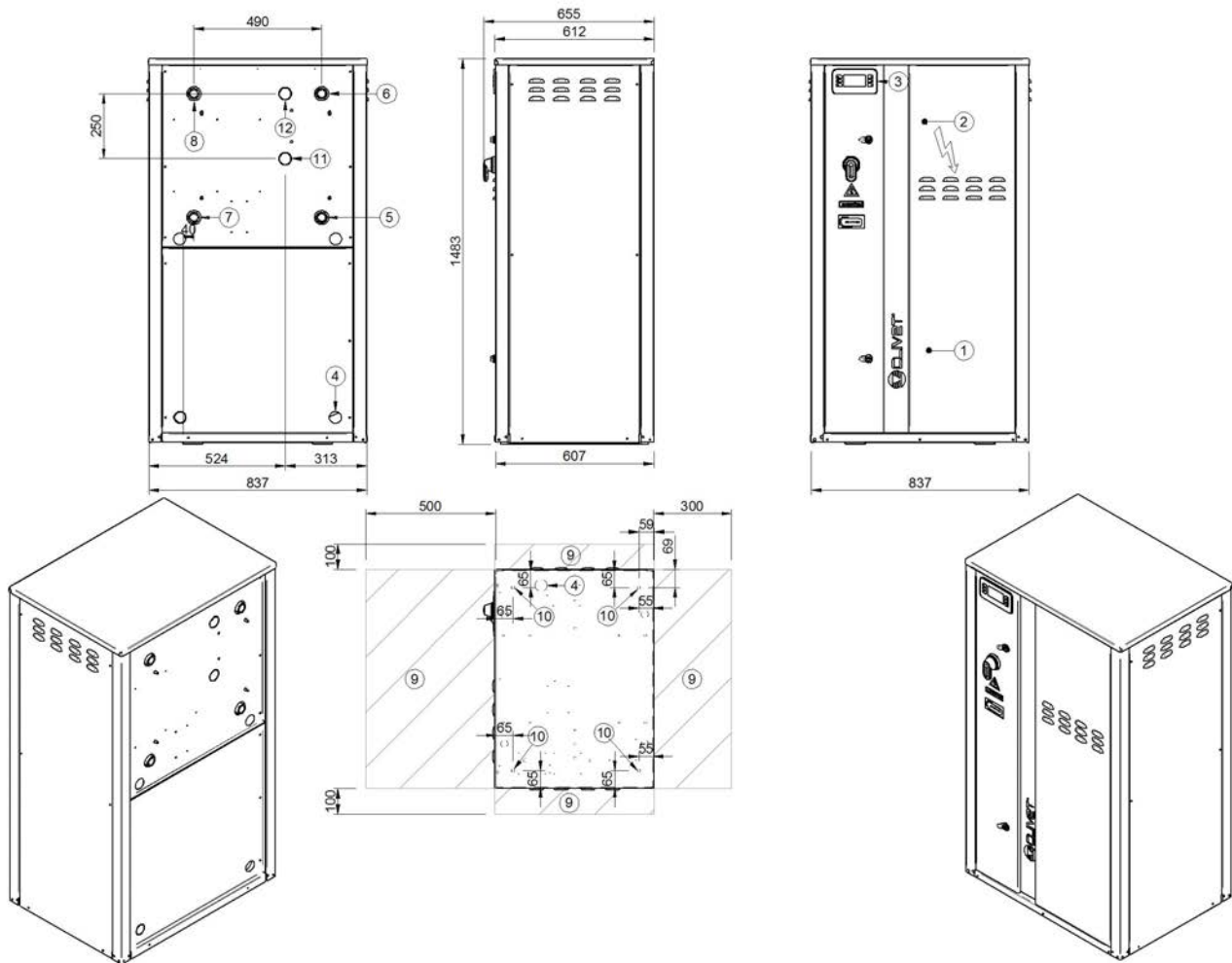

- 1) Compressor compartment
- 2) Electrical panel
- 3) Unit control keypad
- 4) Power input
- 5) Source side water return (1" 1/4 GAS)
- 6) Source side water supply (1" 1/4 GAS)
- 7) User side water return (1" 1/4 GAS)
- 8) User side water supply (1" 1/4 GAS)
- 9) Functional spaces
- 10) Vibration damper mounts Ø 12,5
- 11) Partial recovery water return (1" 1/4 Victaulic) (optional)
- 12) Partial recovery water supply (1" 1/4 Victaulic) (optional)

Size		10.2	12.2	14.2	16.2	19.2	22.2
Length	mm	837	837	837	837	837	837
Height	mm	1483	1483	1483	1483	1483	1483
Depth	mm	607	607	607	607	607	607
Operating weight	kg	223	223	229	290	309	322
Shipping weight	kg	214	214	220	273	288	306

The presence of optional accessories may result in a substantial variation of the weights shown in the table.



# Dimensional - Geothermic version without hydronic unit

Size 10.2 - 22.2

DAA8U10 2\_22 2 STD\_GEO REV01

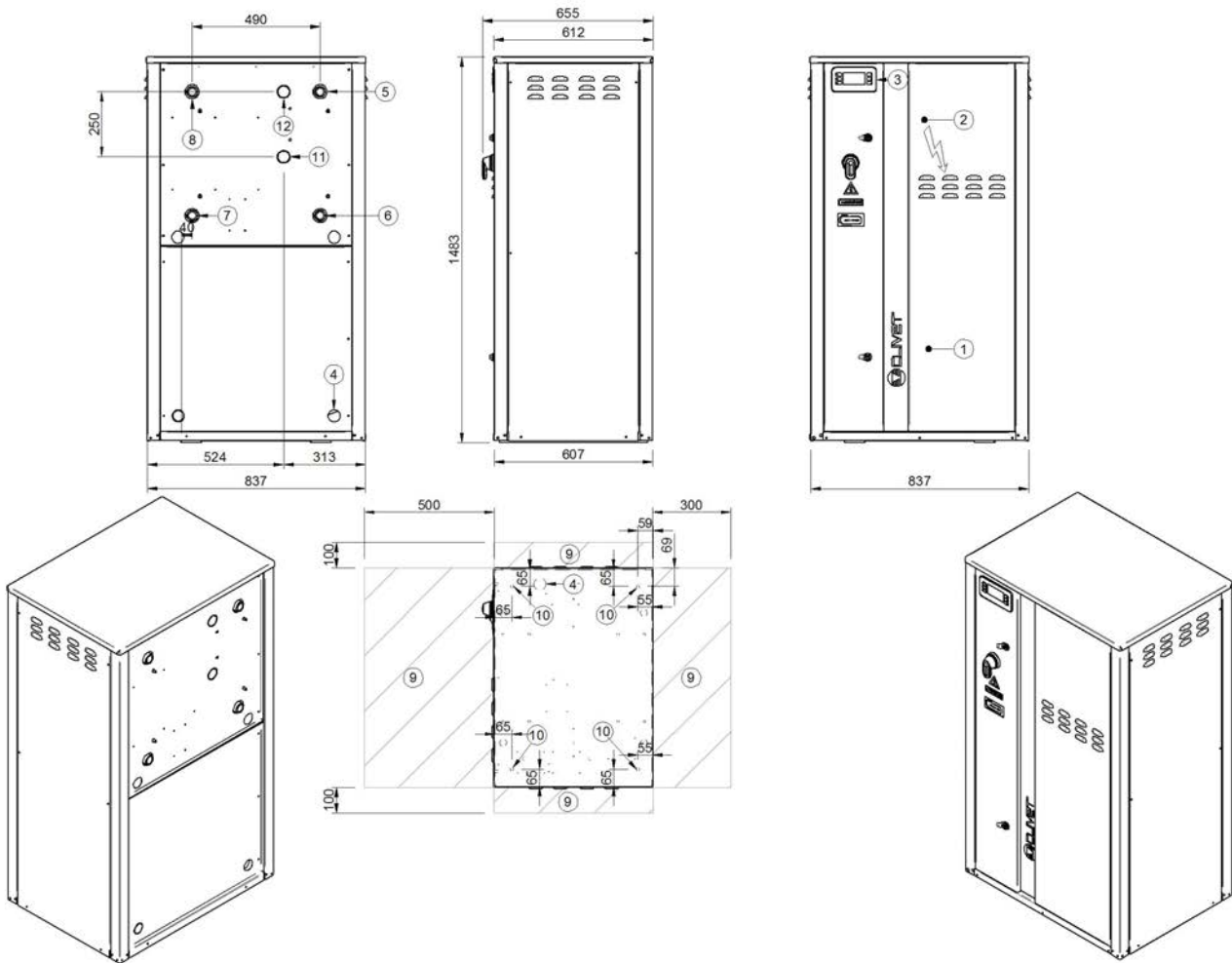

- 1) Compressor compartment
- 2) Electrical panel
- 3) Unit control keypad
- 4) Power input
- 5) Source side water return (1" 1/4 GAS)
- 6) Source side water supply (1" 1/4 GAS)
- 7) User side water return (1" 1/4 GAS)
- 8) User side water supply (1" 1/4 GAS)
- 9) Functional spaces
- 10) Vibration damper mounts Ø 12,5
- 11) Partial recovery water return (1" 1/4 GAS) (optional)
- 12) Partial recovery water supply (1" 1/4 GAS) (optional)

Size		10.2	12.2	14.2	16.2	19.2	22.2
Length	mm	837	837	837	837	837	837
Height	mm	1483	1483	1483	1483	1483	1483
Depth	mm	607	607	607	607	607	607
Operating weight	kg	223	223	229	290	309	322
Shipping weight	kg	214	214	220	273	288	306

The presence of optional accessories may result in a substantial variation of the weights shown in the table.

## Dimensional - Version with hydronic unit option and oversized enclosure (MOBMAG)

Sizes 10.2 - 22.2

DAA8U10\_2\_22 2 MAG REV01

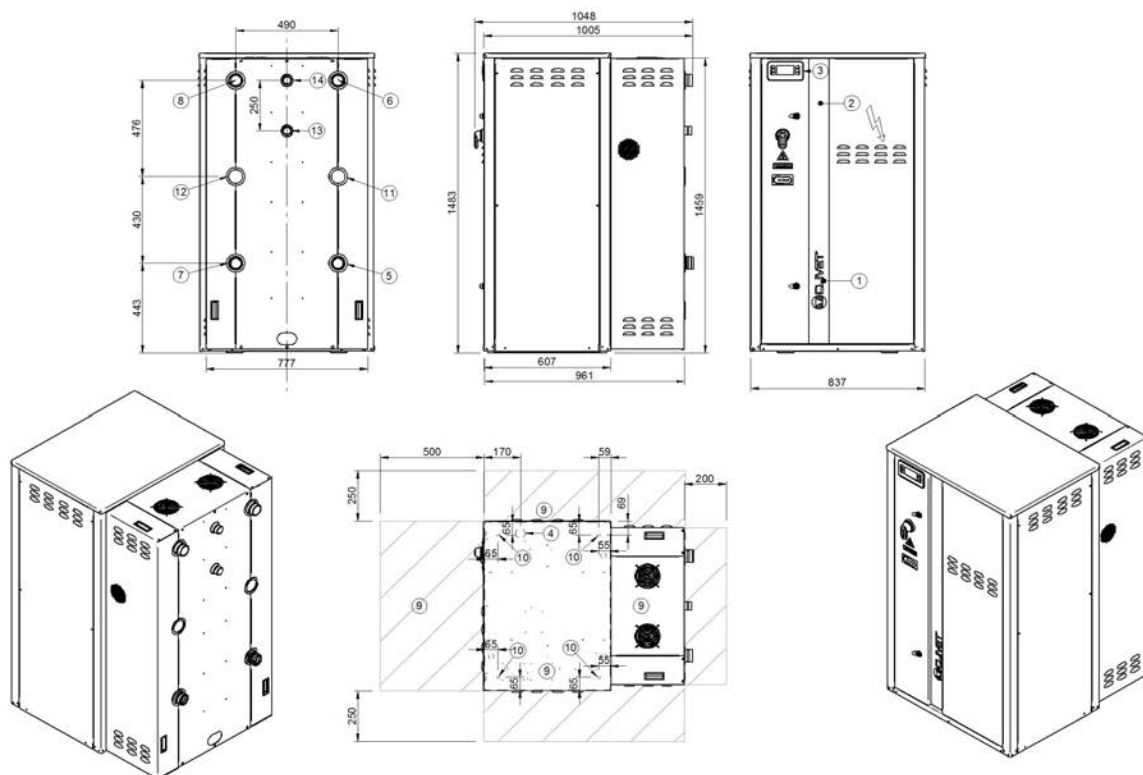

- 1) Compressor compartment
- 2) Electrical panel
- 3) Unit control keypad
- 4) Power input
- 5) Source side water return (2" Victaulic)
- 6) Source side water supply (2" Victaulic)
- 7) User side water return (2" Victaulic)
- 8) User side water supply (2" Victaulic)
- 9) Functional spaces
- 10) Vibration damper mounts  $\varnothing$  12,5
- 11) Source side water return without pumps (2" Victaulic)
- 12) User side water return without pumps (2" Victaulic)
- 13) Partial recovery water supply (1" 1/4 Victaulic) (optional)
- 14) Partial recovery water return (1" 1/4 Victaulic) (optional)

Size	10.2	12.2	14.2	16.2	19.2	22.2
Length	mm 837	837	837	837	837	837
Height	mm 1483	1483	1483	1483	1483	1483
Depth	mm 961	961	961	961	961	961
Operating weight	kg 296	296	305	366	386	399
Shipping weight	kg 276	276	285	338	353	371

The weights refer to the unit equipped with the following options: user side hydronic unit VARYFLOW+ (VARYC), source side hydronic unit VARYFLOW+ (VARYH), oversized enclosure (MOBMAG). The presence of optional accessories may result in a substantial variation of the weights shown in the table.

# Dimensional - Geothermic version with hydronic unit option and oversize enclosure (MOBMAG)

Sizes 10.2 - 22.2

DAA8U10 2\_22 2 MAG GEO REV01

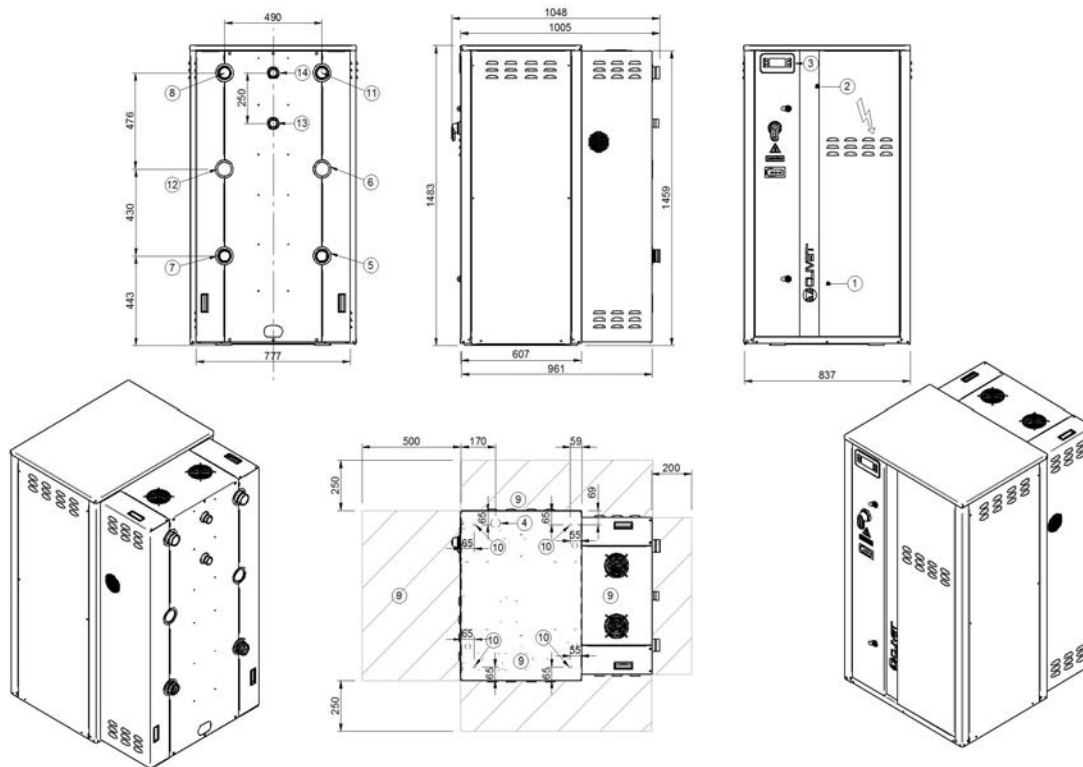

- 1) Compressor compartment
- 2) Electrical panel
- 3) Unit control keypad
- 4) Power input
- 5) Source side water return (2" Victaulic)
- 6) Source side water supply (2" Victaulic)
- 7) User side water return (2" Victaulic)
- 8) User side water supply (2" Victaulic)
- 9) Functional spaces
- 10) Vibration damper mounts  $\varnothing$  12,5
- 11) Source side water return without pumps (2" Victaulic)
- 12) User side water return without pumps (2" Victaulic)
- 13) Partial recovery water supply (1" 1/4 Victaulic) (optional)
- 14) Partial recovery water return (1" 1/4 Victaulic) (optional)

Size		10.2	12.2	14.2	16.2	19.2	22.2
Length	mm	837	837	837	837	837	837
Height	mm	1483	1483	1483	1483	1483	1483
Depth	mm	961	961	961	961	961	961
Operating weight	kg	296	296	305	366	386	399
Shipping weight	kg	276	276	285	338	353	371

The weights refer to the unit equipped with the following options: user side hydronic unit VARYFLOW+ (VARYC), source side hydronic unit VARYFLOW+ (VARYH), oversize enclosure (MOBMAG). The presence of optional accessories may result in a substantial variation of the weights shown in the table.

# Dimensional - Standard version without hydronic unit

Sizes 27.2 - 60.2

DAA8U27 2\_60 2 STD REV01

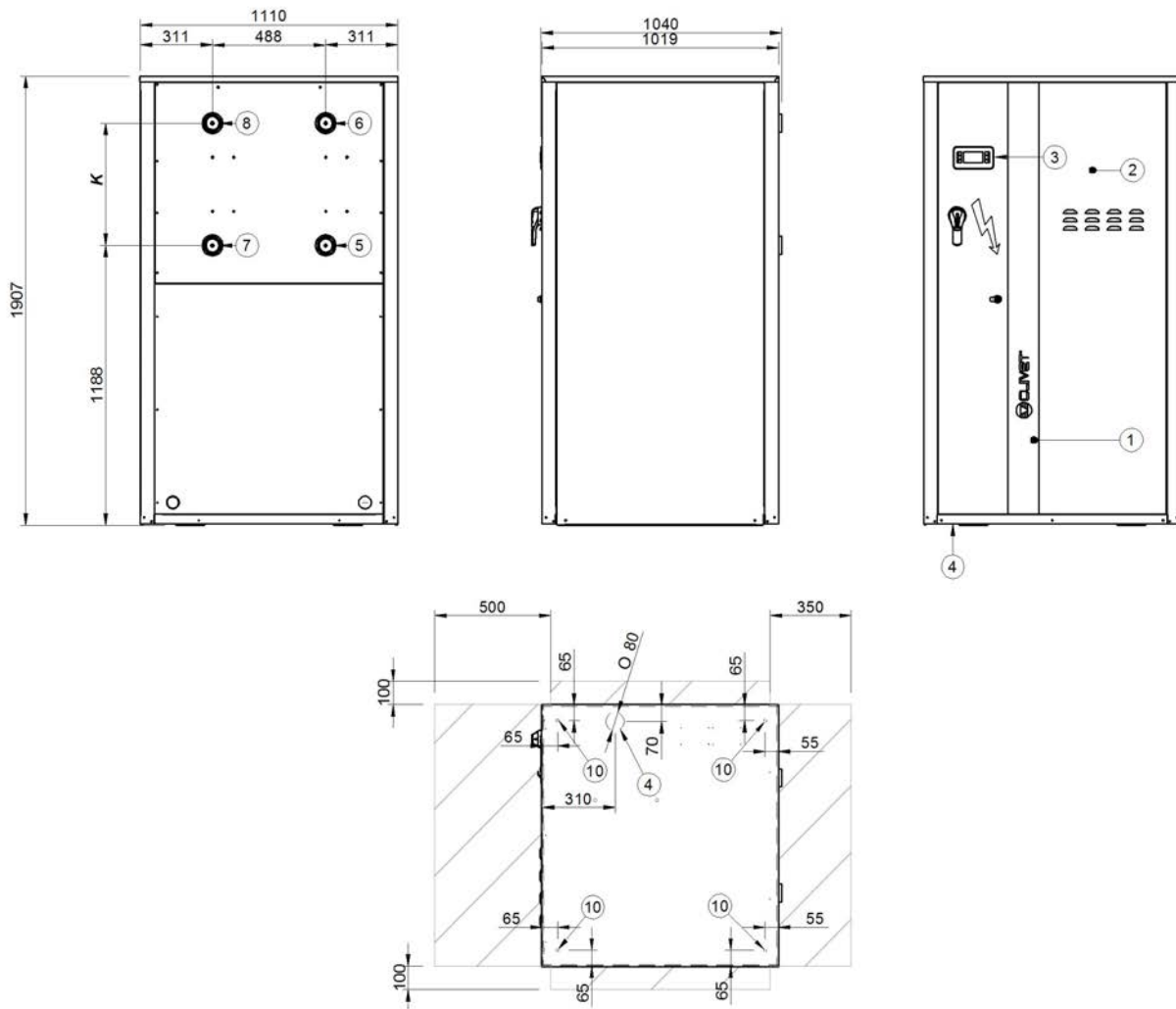

- 1) Compressor compartment
- 2) Electrical panel
- 3) Unit control keypad
- 4) Power input
- 5) Source side water return (2" 1/2 victaulic)
- 6) Source side water supply (2" 1/2 victaulic)
- 7) User side water return (2" 1/2 victaulic)
- 8) User side water supply (2" 1/2 victaulic)
- 9) Functional spaces
- 10) Vibration damper mounts Ø 12,5
- 11) Partial recovery water return (2" 1/2 victaulic) (optional)
- 12) Partial recovery water supply (2" 1/2 victaulic) (optional)

Size		27.2	30.2	35.2	40.2	43.2	45.2	50.2	55.2	60.2
Length	mm	1110	1110	1110	1110	1110	1110	1110	1110	1110
Height	mm	1910	1910	1910	1910	1910	1910	1910	1910	1910
Depth	mm	885	885	885	885	885	885	885	885	885
Operating weight	kg	441	444	519	580	646	581	698	728	743
Shipping weight	kg	436	439	514	568	634	569	677	707	727

The presence of optional accessories may result in a substantial variation of the weights shown in the table.

# Dimensional - Geothermic version without hydronic unit

Sizes 27.2 - 50.2

DAA8U27 2\_50 2 STD\_GEO REV00

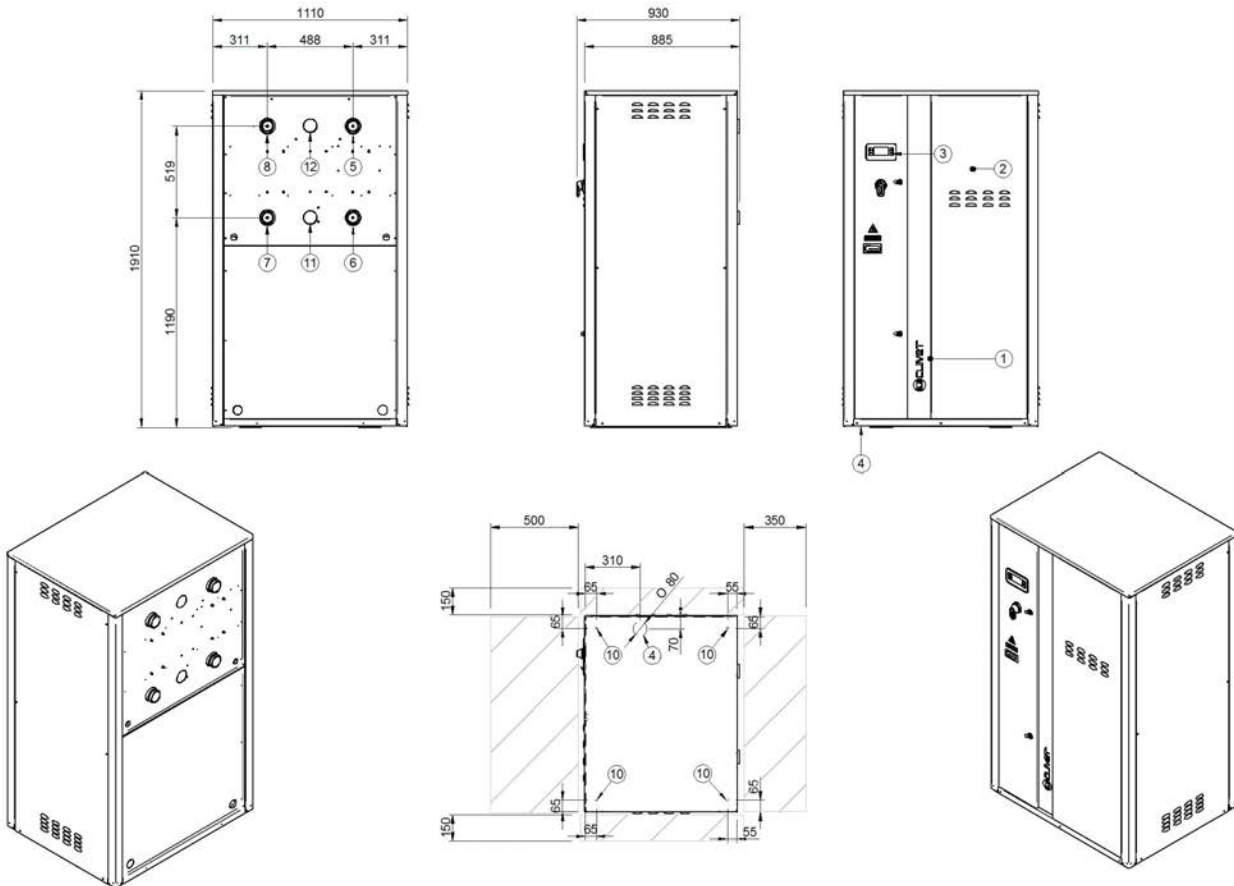

- 1) Compressor compartment
- 2) Electrical panel
- 3) Unit control keypad
- 4) Power input
- 5) Source side water return (2" 1/2 victaulic)
- 6) Source side water supply (2" 1/2 victaulic)
- 7) User side water return (2" 1/2 victaulic)
- 8) User side water supply (2" 1/2 victaulic)
- 9) Functional spaces
- 10) Vibration damper mounts Ø 12,5
- 11) Partial recovery water return (2" 1/2 victaulic) (optional)
- 12) Partial recovery water supply (2" 1/2 victaulic) (optional)

Size		27.2	30.2	35.2	40.2	43.2	45.2	50.2
Length	mm	1110	1110	1110	1110	1110	1110	1110
Height	mm	1910	1910	1910	1910	1910	1910	1910
Depth	mm	885	885	885	885	885	885	885
Operating weight	kg	460	463	538	602	668	616	715
Shipping weight	kg	451	454	529	585	651	596	690

The presence of optional accessories may result in a substantial variation of the weights shown in the table.

# Dimensional - Version with hydronic unit option and oversize enclosure (MOBMAG)

Sizes 27.2 - 60.2

DAA8U27\_2\_60 2 MAG REV01

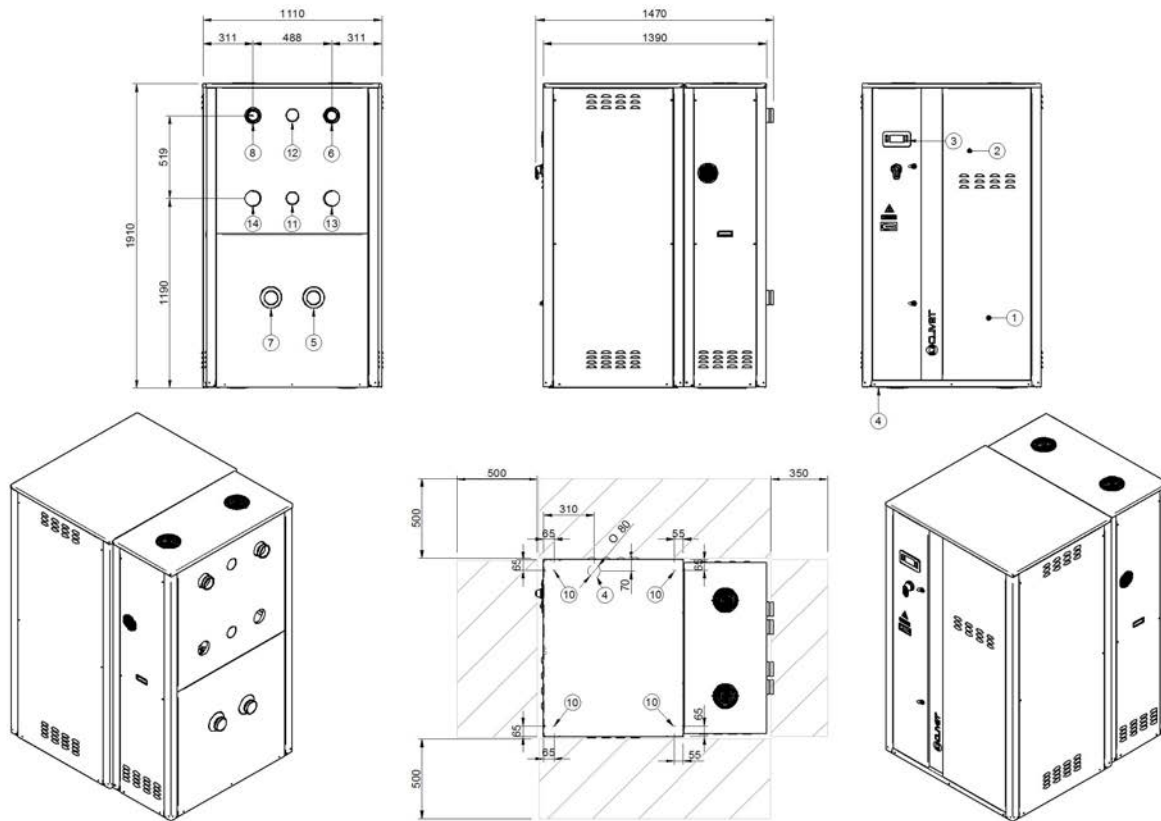

- 1) Compressor compartment
- 2) Electrical panel
- 3) Unit control keypad
- 4) Power input
- 5) Source side water return (3" Victaulic)
- 6) Source side water supply (3" Victaulic)
- 7) User side water return (3" Victaulic)
- 8) User side water supply (3" Victaulic)
- 9) Functional spaces
- 10) Vibration damper mounts  $\varnothing$  12,5
- 11) Partial recovery water return (2" Victaulic) (optional)
- 12) Partial recovery water supply (2" Victaulic) (optional)
- 13) Source side water return without pumps (3" Victaulic)
- 14) User side water return without pumps (3" Victaulic)

Size		27.2	30.2	35.2	40.2	43.2	45.2	50.2	55.2	60.2
Length	mm	1110	1110	1110	1110	1110	1110	1110	1110	1110
Height	mm	1910	1910	1910	1910	1910	1910	1910	1910	1910
Depth	mm	1390	1390	1390	1390	1390	1390	1390	1390	1390
Operating weight	kg	587	590	665	734	817	752	868	906	921
Shipping weight	kg	552	555	630	692	759	694	802	840	860

The weights refer to the unit equipped with the following options: user side hydronic unit VARYFLOW+ (VARYC), source side hydronic unit VARYFLOW+ (VARYH), oversize enclosure (MOBMAG). The presence of optional accessories may result in a substantial variation of the weights shown in the table.

# Dimensional - Geothermic version with hydronic unit option and oversize enclosure (MOBMAG)

Sizes 27.2 - 50.2

DAA8U27\_2\_50 2 MAG\_GEO REV01

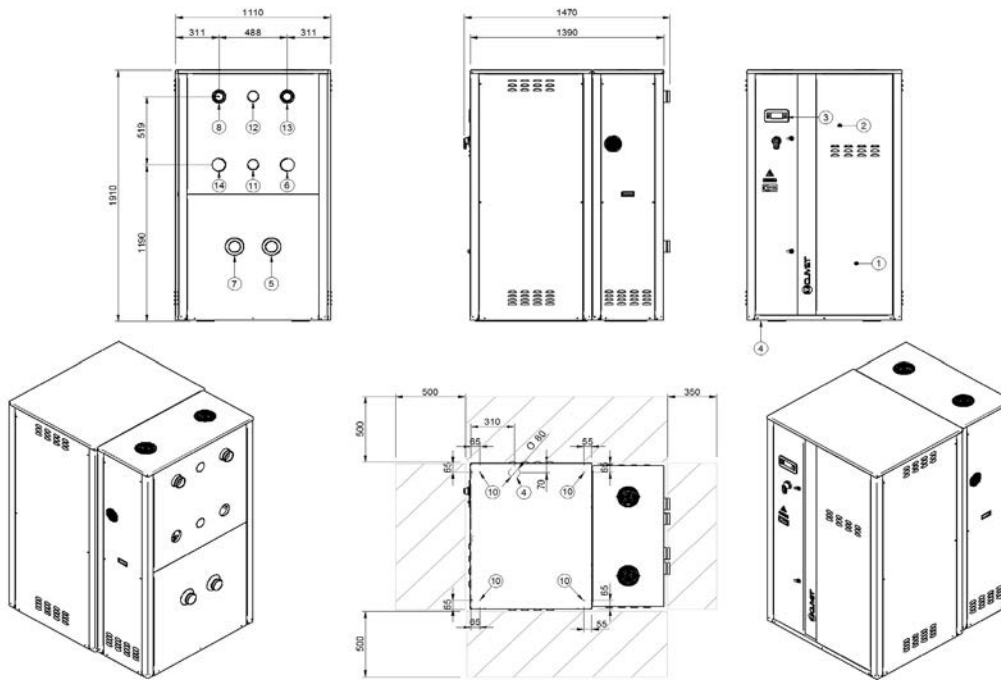

- 1) Compressor compartment
- 2) Electrical panel
- 3) Unit control keypad
- 4) Power input
- 5) Source side water return (3" Victaulic)
- 6) Source side water supply (3" Victaulic)
- 7) User side water return (3" Victaulic)
- 8) User side water supply (3" Victaulic)
- 9) Functional spaces
- 10) Vibration damper mounts  $\varnothing$  12,5
- 11) Partial recovery water return (2" Victaulic) (optional)
- 12) Partial recovery water supply (2" Victaulic) (optional)
- 13) Source side water return without pumps (3" Victaulic)
- 14) User side water return without pumps (3" Victaulic)

Size		27.2	30.2	35.2	40.2	43.2	45.2	50.2
Length	mm	1110	1110	1110	1110	1110	1110	1110
Height	mm	1910	1910	1910	1910	1910	1910	1910
Depth	mm	1390	1390	1390	1390	1390	1390	1390
Operating weight	kg	606	609	684	756	838	787	885
Shipping weight	kg	567	570	645	709	776	721	815

The weights refer to the unit equipped with the following options: user side hydronic unit VARYFLOW+ (VARYC), source side hydronic unit VARYFLOW+ (VARYH), oversize enclosure (MOBMAG). The presence of optional accessories may result in a substantial variation of the weights shown in the table.

# Dimensional - Standard version without hydronic unit

Sizes 70.2 - 90.2

DAA8U70 2\_90 2 STD REV00

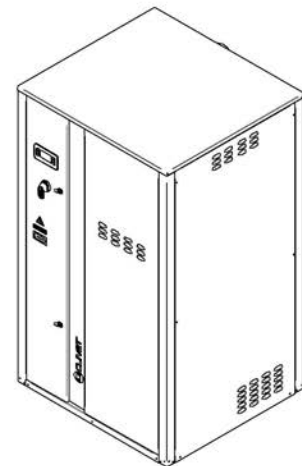
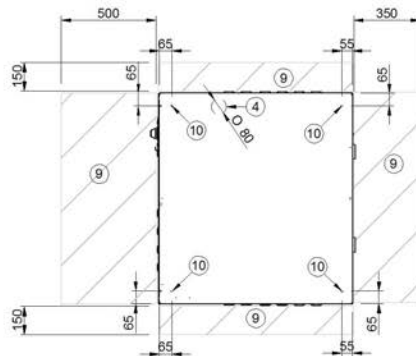
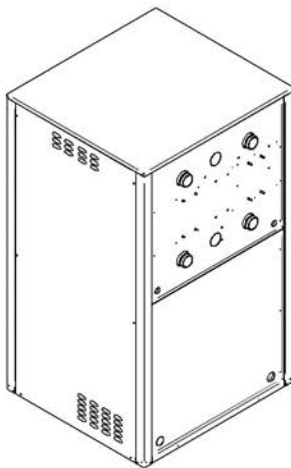
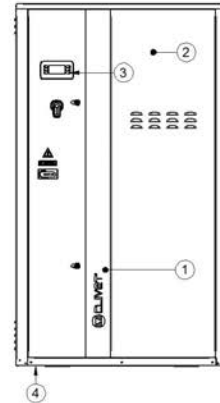
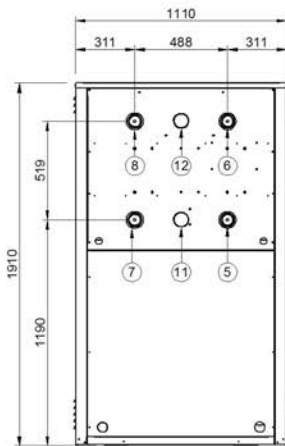

- 1) Compressor compartment
- 2) Electrical panel
- 3) Unit control keypad
- 4) Power input
- 5) Source side water return (2" 1/2 Victaulic)
- 6) Source side water supply (2" 1/2 Victaulic)
- 7) User side water return (2" 1/2 Victaulic)
- 8) User side water supply (2" 1/2 Victaulic)
- 9) Functional spaces
- 10) Vibration damper mounts Ø 12,5
- 11) Partial recovery water return (2" 1/2 Victaulic) (optional)
- 12) Partial recovery water supply (2" 1/2 Victaulic) (optional)

Size		70.2	80.2	90.2
Length	mm	1110	1110	1110
Height	mm	1910	1910	1910
Depth	mm	1035	1035	1035
Operating weight	kg	808	820	917
Shipping weight	kg	780	792	885

The presence of optional accessories may result in a substantial variation of the weights shown in the table.



# Dimensional - Geothermic version without hydronic unit

## Size 55.2 - 90.2

DAA8U55\_2\_90\_2 STD\_GEO REV00

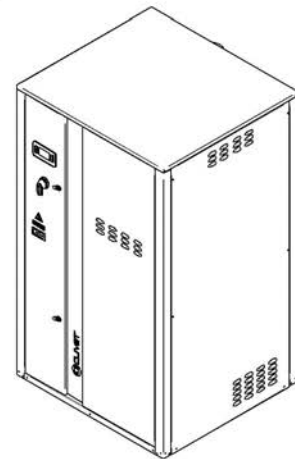
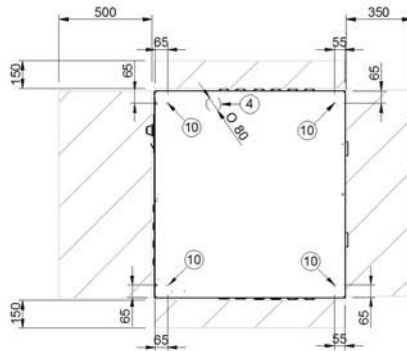
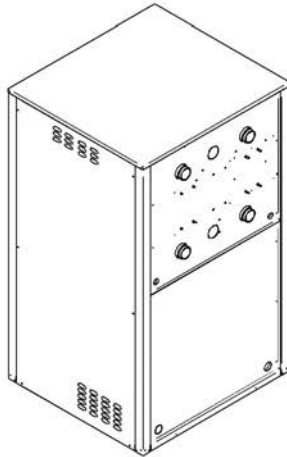
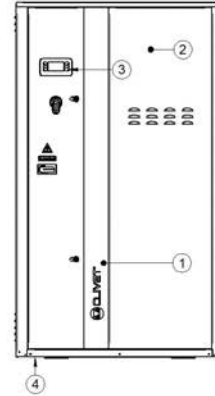
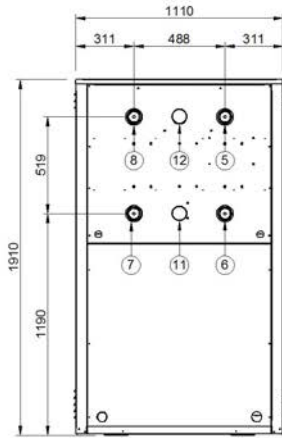

- 1) Compressor compartment
- 2) Electrical panel
- 3) Unit control keypad
- 4) Power input
- 5) Source side water return (2" 1/2 Victaulic)
- 6) Source side water supply (2" 1/2 Victaulic)
- 7) User side water return (2" 1/2 Victaulic)
- 8) User side water supply (2" 1/2 Victaulic)
- 9) Functional spaces
- 10) Vibration damper mounts  $\varnothing 12,5$
- 11) Partial recovery water return (2" 1/2 Victaulic) (optional)
- 12) Partial recovery water supply (2" 1/2 Victaulic) (optional)

Size		55.2	60.2	70.2	80.2	90.2
Length	mm	1110	1110	1110	1110	1110
Height	mm	1910	1910	1910	1910	1910
Depth	mm	1035	1035	1035	1035	1035
Operating weight	kg	768	783	840	852	940
Shipping weight	kg	738	758	805	817	903

The presence of optional accessories may result in a substantial variation of the weights shown in the table.

# Dimensional - Version with hydronic unit option and oversize enclosure (MOBMAG)

Size 70.2 - 90.2

DAA8U70\_2\_90 2 MAG REV00

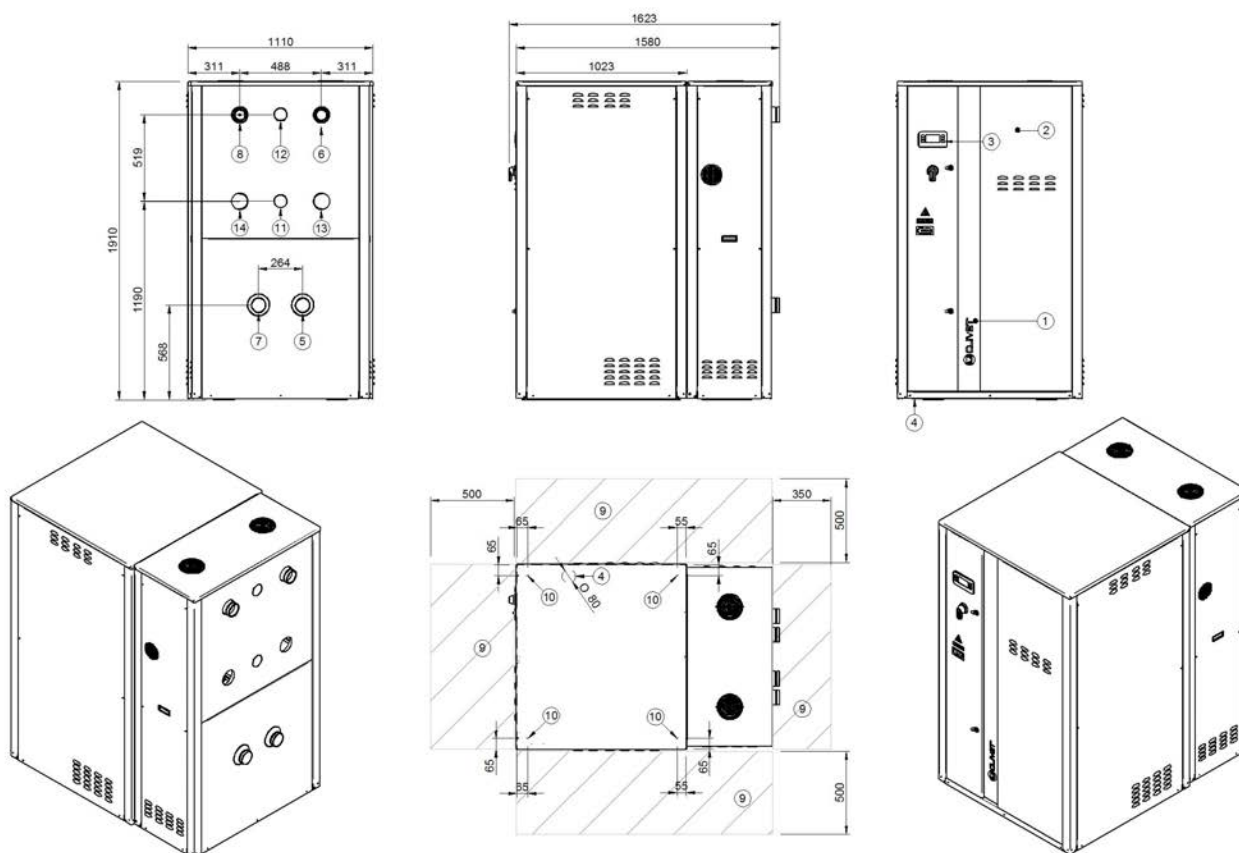

- 1) Compressor compartment
- 2) Electrical panel
- 3) Unit control keypad
- 4) Power input
- 5) Source side water return (3" Victaulic)
- 6) Source side water supply (3" Victaulic)
- 7) User side water return (3" Victaulic)
- 8) User side water supply (3" Victaulic)
- 9) Functional spaces
- 10) Vibration damper mounts  $\varnothing$  12,5
- 11) Partial recovery water return (2" Victaulic) (optional)
- 12) Partial recovery water supply (2" Victaulic) (optional)
- 13) Source side water return without pumps (3" Victaulic)
- 14) User side water return without pumps (3" Victaulic)

Size		70.2	80.2	90.2
Length	mm	1110	1110	1110
Height	mm	1910	1910	1910
Depth	mm	1580	1580	1580
Operating weight	kg	992	1004	1130
Shipping weight	kg	919	931	1027

The weights refer to the unit equipped with the following options: user side hydronic unit VARYFLOW+ (VARYC), source side hydronic unit VARYFLOW+ (VARYH), oversize enclosure (MOBMAG). The presence of optional accessories may result in a substantial variation of the weights shown in the table.

# Dimensional - Geothermic version with hydronic unit option and oversize enclosure (MOBMAG)

Size 55.2 - 90.2

DAA8U55 2\_90 2 MAG\_GEO REV00

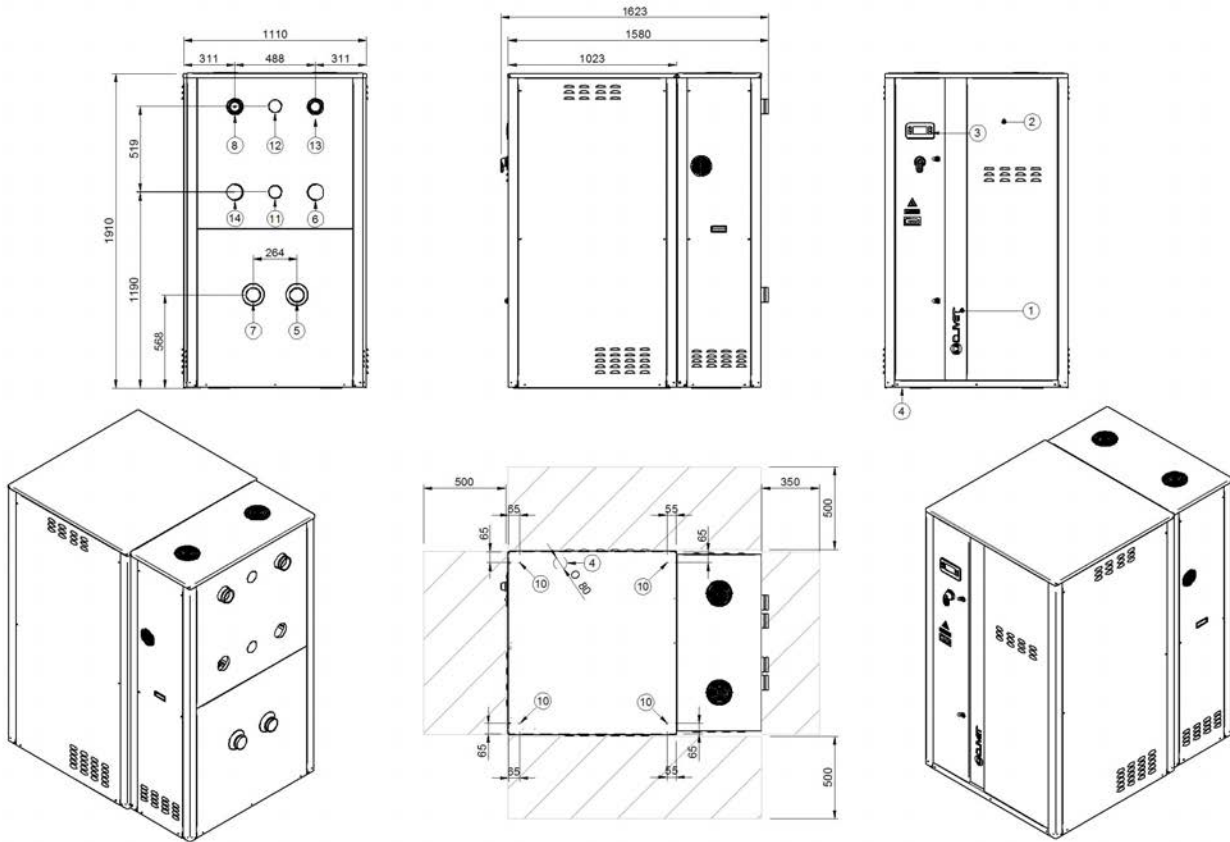

- 1) Compressor compartment
- 2) Electrical panel
- 3) Unit control keypad
- 4) Power input
- 5) Source side water return (3" Victaulic)
- 6) Source side water supply (3" Victaulic)
- 7) User side water return (3" Victaulic)
- 8) User side water supply (3" Victaulic)
- 9) Functional spaces
- 10) Vibration damper mounts Ø 12,5
- 11) Partial recovery water return (2" victaulic) (optional)
- 12) Partial recovery water supply (2" victaulic) (optional)
- 13) Source side water return without pumps (3" Victaulic)
- 14) User side water return without pumps (3" Victaulic)

Size		55.2	60.2	70.2	80.2	90.2
Length	mm	1110	1110	1110	1110	1110
Height	mm	1910	1910	1910	1910	1910
Depth	mm	1580	1580	1580	1580	1580
Operating weight	kg	946	961	1024	1036	1152
Shipping weight	kg	871	891	944	956	1045

The weights refer to the unit equipped with the following options: user side hydronic unit VARYFLOW+ (VARYC), source side hydronic unit VARYFLOW+ (VARYH), oversize enclosure (MOBMAG)

The presence of optional accessories may result in a substantial variation of the weights shown in the table

# Dimensional - Standard version without hydronic unit

## Size 100.2 - 120.2

DAA8U100 2\_120 2 STD REV00

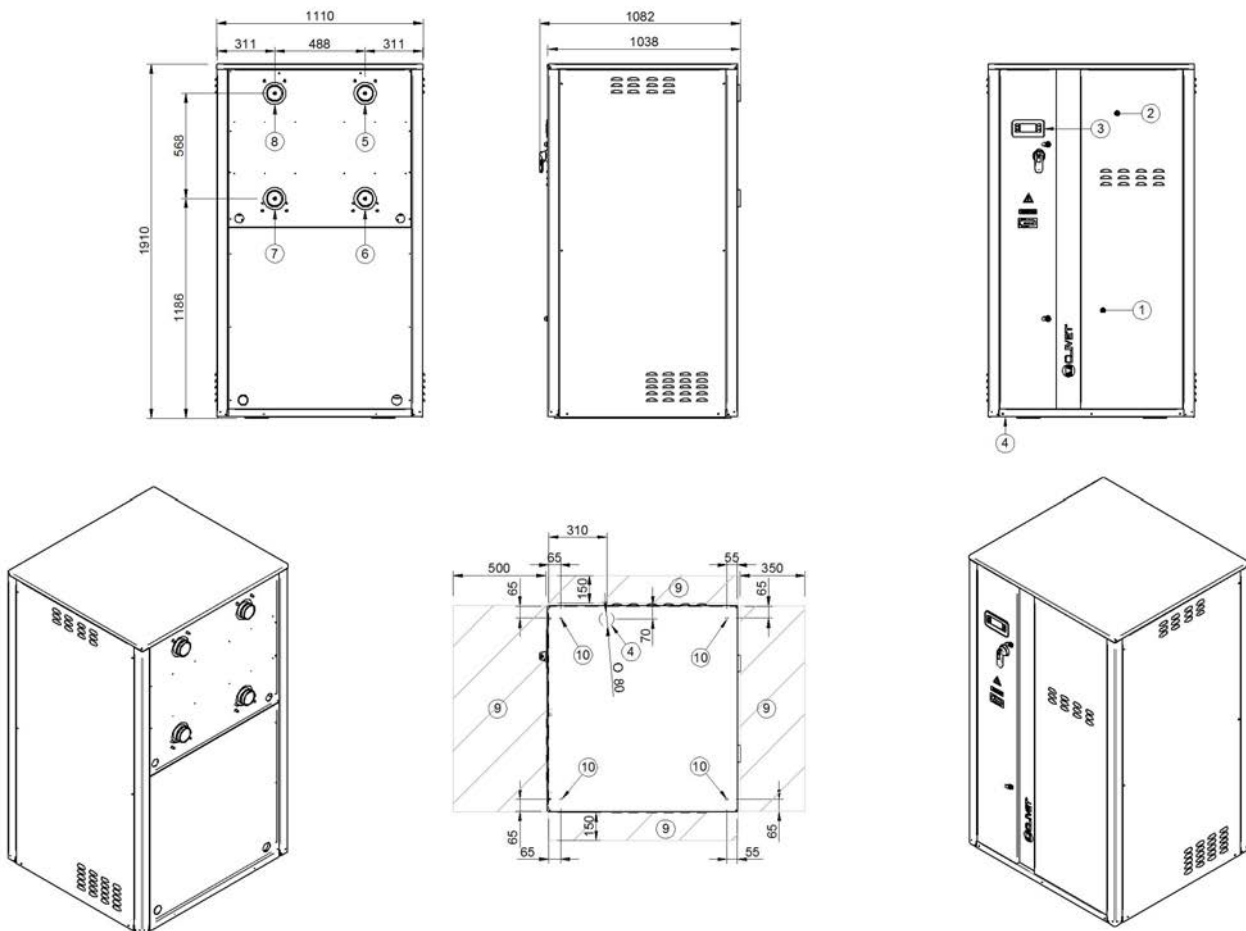

- 1) Compressor compartment
- 2) Electrical panel
- 3) Unit control keypad
- 4) Power input
- 5) Source side water return (3" Victaulic)
- 6) Source side water supply (3" Victaulic)
- 7) User side water return (3" Victaulic)
- 8) User side water supply (3" Victaulic)
- 9) Functional spaces
- 10) Vibration damper mounts  $\varnothing$  12,5

Size		100.2	120.2
Length	mm	1110	1110
Height	mm	1910	1910
Depth	mm	1038	1038
Operating weight	kg	1119	1265
Shipping weight	kg	1040	1176

The presence of optional accessories may result in a substantial variation of the weights shown in the table

# Dimensional - Geothermic version without hydronic unit

## Size 100.2 - 120.2

DAA8U100 2\_120 2 STD\_GEO REV00

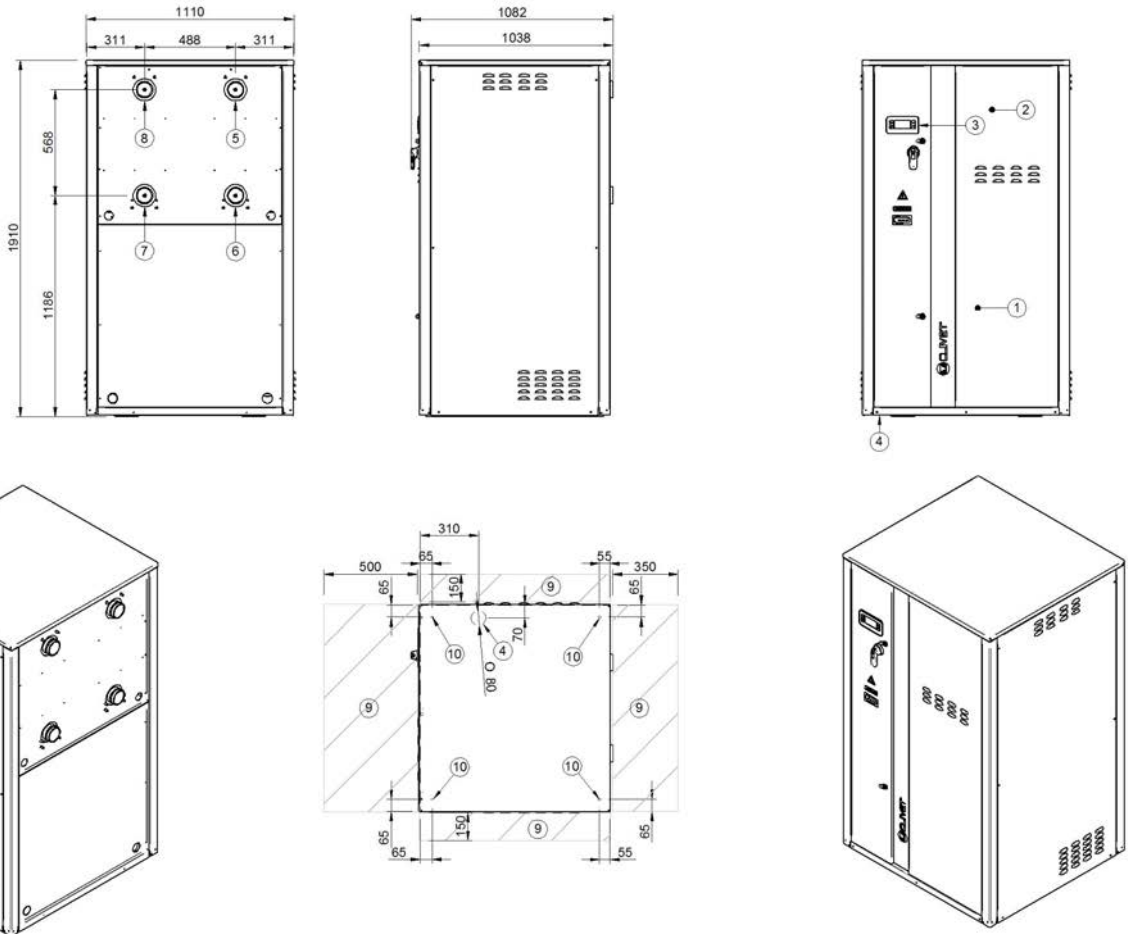

- 1) Compressor compartment
- 2) Electrical panel
- 3) Unit control keypad
- 4) Power input
- 5) Source side water return (3" Victaulic)
- 6) Source side water supply (3" Victaulic)
- 7) User side water return (3" Victaulic)
- 8) User side water supply (3" Victaulic)
- 9) Functional spaces
- 10) Vibration damper mounts Ø 12,5

Size	100.2	120.2
Length	mm 1110	1110
Height	mm 1910	1910
Depth	mm 1038	1038
Operating weight	kg 1119	1265
Shipping weight	kg 1040	1176

The presence of optional accessories may result in a substantial variation of the weights shown in the table

# Dimensional - Version with hydronic unit option and oversize enclosure (MOBMAG)

Size 100.2 - 120.2

DAA8U100\_2\_120\_2 MAG REV00  
DATA/DATE 07/03/2019

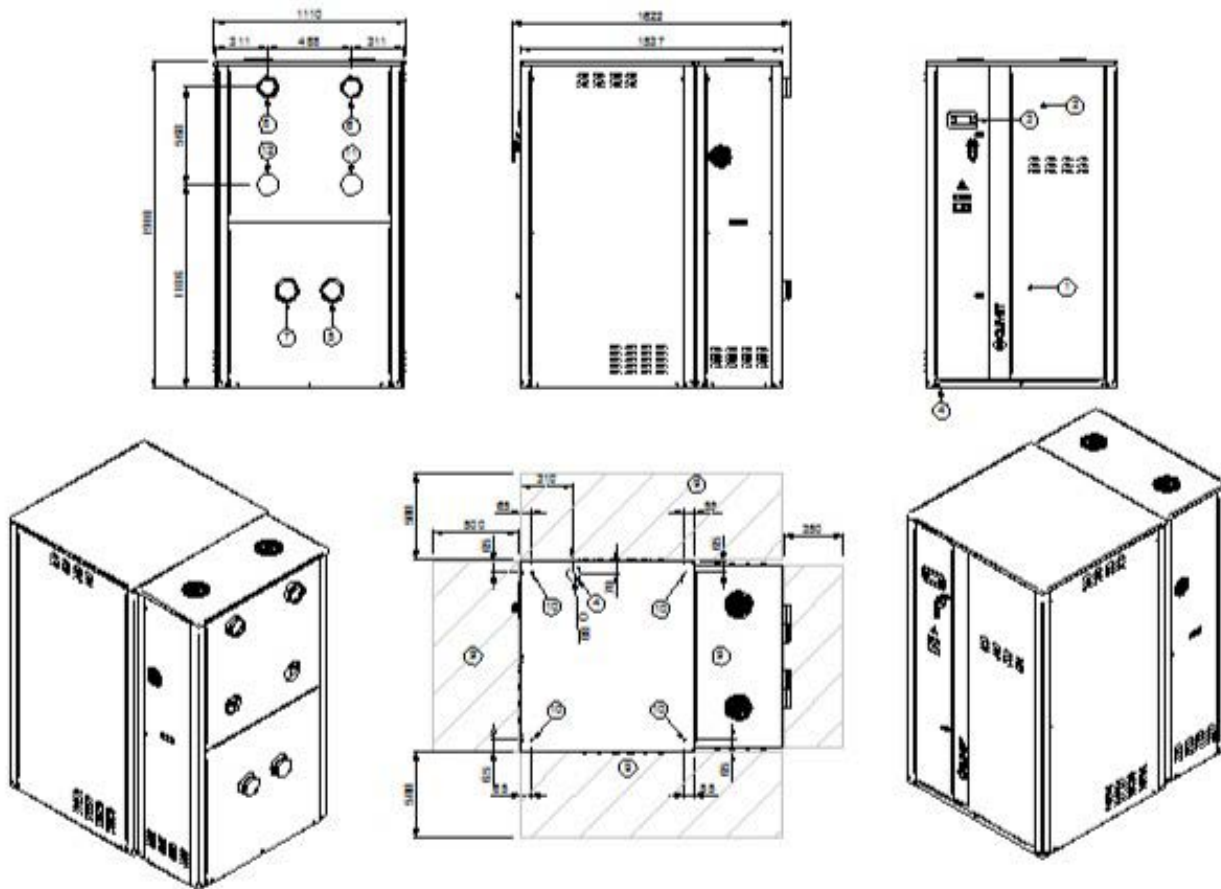

- 1) Compressor compartment
- 2) Electrical panel
- 3) Unit control keypad
- 4) Power input
- 5) Source side water return (4" Victaulic)
- 6) Source side water supply (4" Victaulic)
- 7) User side water return (4" Victaulic)
- 8) User side water supply (4" Victaulic)
- 9) Functional spaces
- 10) Vibration damper mounts Ø 12,5
- 11) Source side water return without pumps (4" Victaulic)
- 12) User side water return without pumps (4" Victaulic)

Size		100.2	120.2
Length	mm	1110	1110
Height	mm	1910	1910
Depth	mm	1537	1537
Operating weight	kg	1335	1482
Shipping weight	kg	1186	1322

The weights refer to the unit equipped with the following options: user side hydronic unit VARYFLOW+ (VARYC), source side hydronic unit VARYFLOW+ (VARYH), oversize enclosure (MOBMAG)

The presence of optional accessories may result in a substantial variation of the weights shown in the table

# Dimensional - Geothermic version with hydronic unit option and oversize enclosure (MOBMAG)

Size 100.2 - 120.2

DAA8U100 2\_120 2 MAG\_GEO REV00  
DATA/DATE 07/03/2019

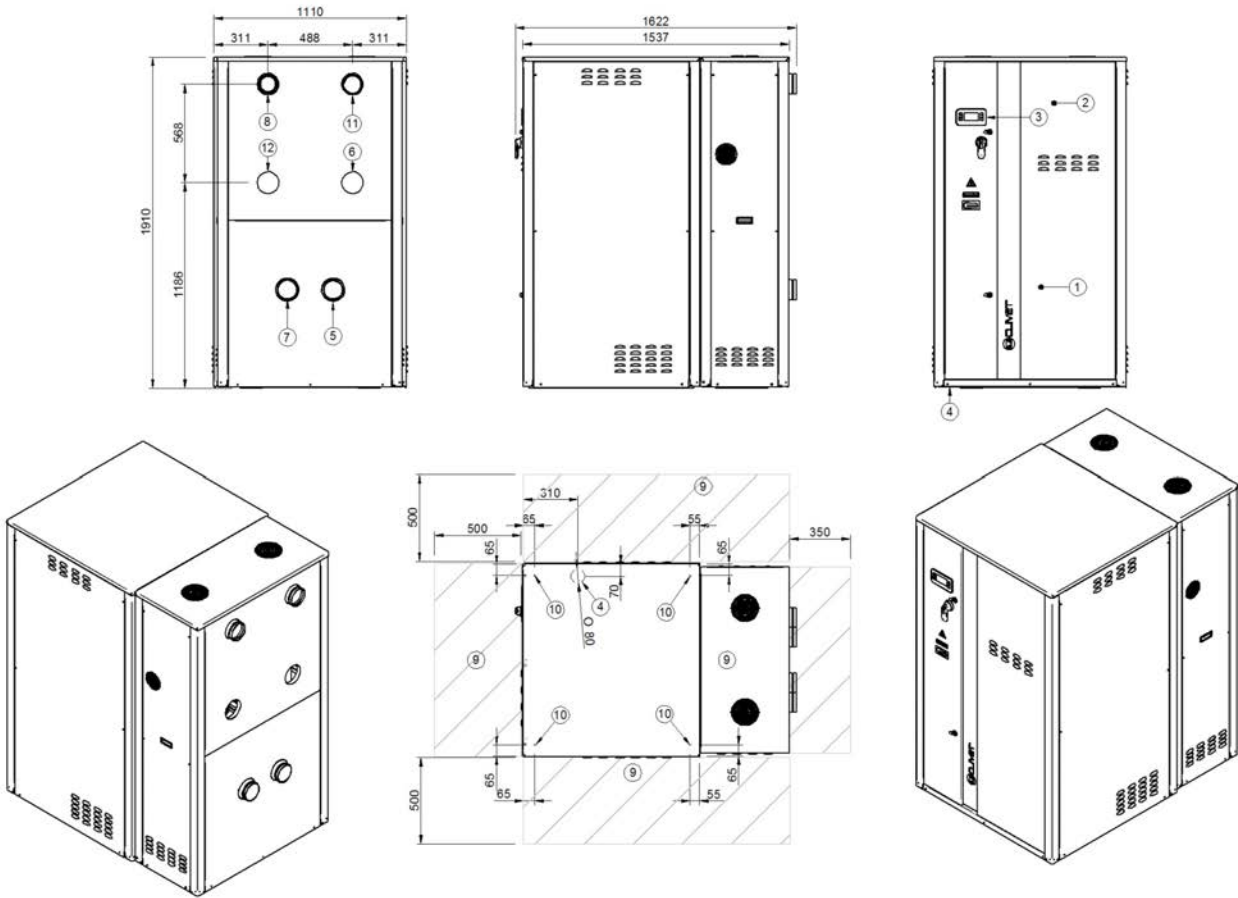

- 1) Compressor compartment
- 2) Electrical panel
- 3) Unit control keypad
- 4) Power input
- 5) Source side water return (4" Victaulic)
- 6) Source side water supply (4" Victaulic)
- 7) User side water return (4" Victaulic)
- 8) User side water supply (4" Victaulic)
- 9) Functional spaces
- 10) Vibration damper mounts Ø 12,5
- 11) Source side water return without pumps (4" Victaulic)
- 12) User side water return without pumps (4" Victaulic)

Size		100.2	120.2
Length	mm	1110	1110
Height	mm	1910	1910
Depth	mm	1537	1537
Operating weight	kg	1335	1482
Shipping weight	kg	1186	1322

The weights refer to the unit equipped with the following options: user side hydronic unit VARYFLOW+ (VARYC), source side hydronic unit VARYFLOW+ (VARYH), oversize enclosure (MOBMAG)

The presence of optional accessories may result in a substantial variation of the weights shown in the table



**CLIVET**®

---

**CLIVET SPA**

Via Camp Lonc 25, Z.I. Villapaiera - 32032 Feltre (BL) - Italy  
Tel. + 39 0439 3131 - Fax + 39 0439 313300 - info@clivet.it

**CLIVET UK LTD (Sales)**

4 Kingdom Close, Segensworth East - Fareham, Hampshire - PO15 5TJ - United Kingdom  
Tel. + 44 (0) 1489 572238 - Fax + 44 (0) 1489 573033 - info@clivet-uk.co.uk

**CLIVET AIRCON LTD (Service and Maintenance Division)**

Units F5&F6 Railway Triangle Ind Est, Walton Road - Portsmouth, Hampshire - PO6 1TG - United Kingdom  
Tel. +44 (0) 2392 381235 - Fax. +44 (0) 2392 381243 - info@clivetaircon.co.uk

**CLIVET ESPAÑA S.A.U.**

C/ Bac de Roda, 36 - 08019 Barcelona - España  
Tel: +34 93 8606248 - Fax +34 93 8855392 - info@clivet.es

Av.Manoteras Nº 38, Oficina C303 - 28050 adrid - España  
Tel. +34 91 6658280 - Fax +34 91 6657806 - info@clivet.es

**CLIVET GmbH (Hydronic and Applied Division)**

Hummelsbütteler Steindamm 84, 22851 Norderstedt - Germany  
Tel. + 49 (0) 40 32 59 57-0 - Fax + 49 (0) 40 32 59 57-194 - info.de@clivet.com

**CLIVET GmbH (VRF, Residential and Lightcom Division)**

Eisenstrasse 9c, 65428 Rüsselsheim/Frankfurt - Germany  
Tel. + 49 (0) 6142 83594-0 - Fax + 49 (0) 6142 83594-20 - vrf.de@clivet.com

**CLIVET RUSSIA**

Elektrozavodskaya st. 24, office 509 - 107023, Moscow, Russia  
Tel. + 74956462009 - Fax + 74956462009 - info.ru@clivet.com

**CLIVET MIDEAST FZCO**

Dubai Silicon Oasis (DSO), High Bay Complex, Office N. 20, PO BOX 342009, Dubai, UAE  
Tel. + 9714 3208499 - Fax + 9714 3208216 - info@clivet.ae

**CLIVET AIRCONDITIONING SYSTEMS PRIVATE LIMITED**

4BA, Gundecha Onclave, Kherani Road - Sakinaka, Andheri (East) - Mumbai 400 072 - India  
Tel. +91 22 6193 7000 - Fax +91 22 6193 7001 - info.in@clivet.com

---

[www.clivet.com](http://www.clivet.com)  
[www.clivetlive.com](http://www.clivetlive.com)