

ELFORoom² 003.0-017.0

Cased or uncased water terminal unit for vertical and horizontal installation

HOMOGENOUS TEMPERATURES AT ALL TIMES

Eliminates air temperature stratifications thanks to the continuous modulation of the fan speed

REDUCED CONSUMPTION

The exclusive DC motor allows to considerably reduce consumption

100% SILENT OPERATION

The fan's continuous operation allows the appliance to always operate by automatically preferring low ventilation speeds in favour of silence

PURIFIES THE AIR WHILE CONDITIONING

The continuous fan operating allows the unit to operate always privileging automatically the lower fan speeds in favour of the silence

SATISFIES ALL INSTALLATIONS

Available in both the vertical and horizontal uncased and built-in version



Heating capacity (W45/A20) from 0.9 to 4.1 kW
Cooling capacity (W7/A27) from 0.8 to 4.1 kW



Change living home

Table of contents

ELFOSystem Gaia Edition	4
A single smart system	5
ELFOSystem components	6
ELFORoom ²	8
Control functions.....	10
ELFOControl ² : the centralized Clivet control	12
Unit technical features	13
Unit configuration.....	15
General technical data.....	16
Electrical date	16
Sound levels	17
Operating range	18
Water side pressure drops.....	19
Performances in cooling	21
Performance in Heating	22
Static heating performance.....	23
Cooling capacity corrective coefficient as a function of the water flow rate	24
Heating capacity corrective coefficient as a function of the water flow rate	25
Correction factors of cooling efficiency as a function of the air flow rate	26
Correction factors of heating efficiency as a function of the air flow rate	27
Variation of air flow rate as a function of available pressure for two-pipe systems.....	28
Variation of air flow rate as a function of available pressure for four-pipe systems.....	29
Description of electronic equipments.....	30
Canfiguration options.....	31
Performance in heating with 4-pipes coil	33
Accessories separately supplied	34
Dimensional drawings.....	40
4 pipes version dimensional drawings.....	41
Pattern for installation	42
Clearance access recommended	44
Description per specification of supply	45

ELFOsystem Gaia Edition

ELFORoom² is part of ElfoSystem and GAIA is the heart of ELFOsystem that Clivet has designed for residential installations.



A system that looks toward the future

- It does not use fossil fuels
- It uses renewable energy from 75 up to 100%
- Substantially contributes toward reaching the European targets of 20-20-20 by 2020 (reduction of CO2 emissions, primary energy and use of renewable energy)



Qualifying proposal

- Specialized solution with high value added
- Single annual cycle system for total comfort
- Increases the building's energy efficiency by at least 2 classes

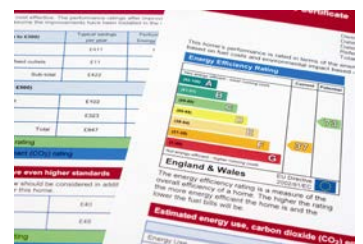

A single smart system

A single smart system with all the elements that generate year-round comfort:

- Heating
- Cooling
- Domestic hot water
- Air renewal and purification
- Humidity control



Easy to install System

- Industrialized solution that permits a quick and high quality installation
- Excludes installation and adjustment errors
- Wirings and connections are clear and preconfigured



Economically convenient

- Thanks to the high energy efficiency levels it increases the value of the property. The investment pays back for itself in 3-4 years on average
- 60% reduction of the space in the heating room
- Complies with the minimum requirements for existing financial incentives.



ELFOSystem components

Production GAIA

High efficiency heat pump for the heat/cool and domestic hot water production

- Packaged unit for the comfort by using renewable energy
- Integrated system to recover solar energy from thermal manifolds
- Integrated domestic hot water production
- System with the best seasonal efficiency on the market
- Water production up to 60°C, operating with outdoor air temperature down to -22°C
- Air and water version

Pre-assembled control unit

Compared with a traditional combustion system, GAIA offers three key benefits:

- It does not require a gas feed, flues and explosion security systems
- Encloses all of the system elements
- In a single unit it includes heating, cooling and solar thermal store

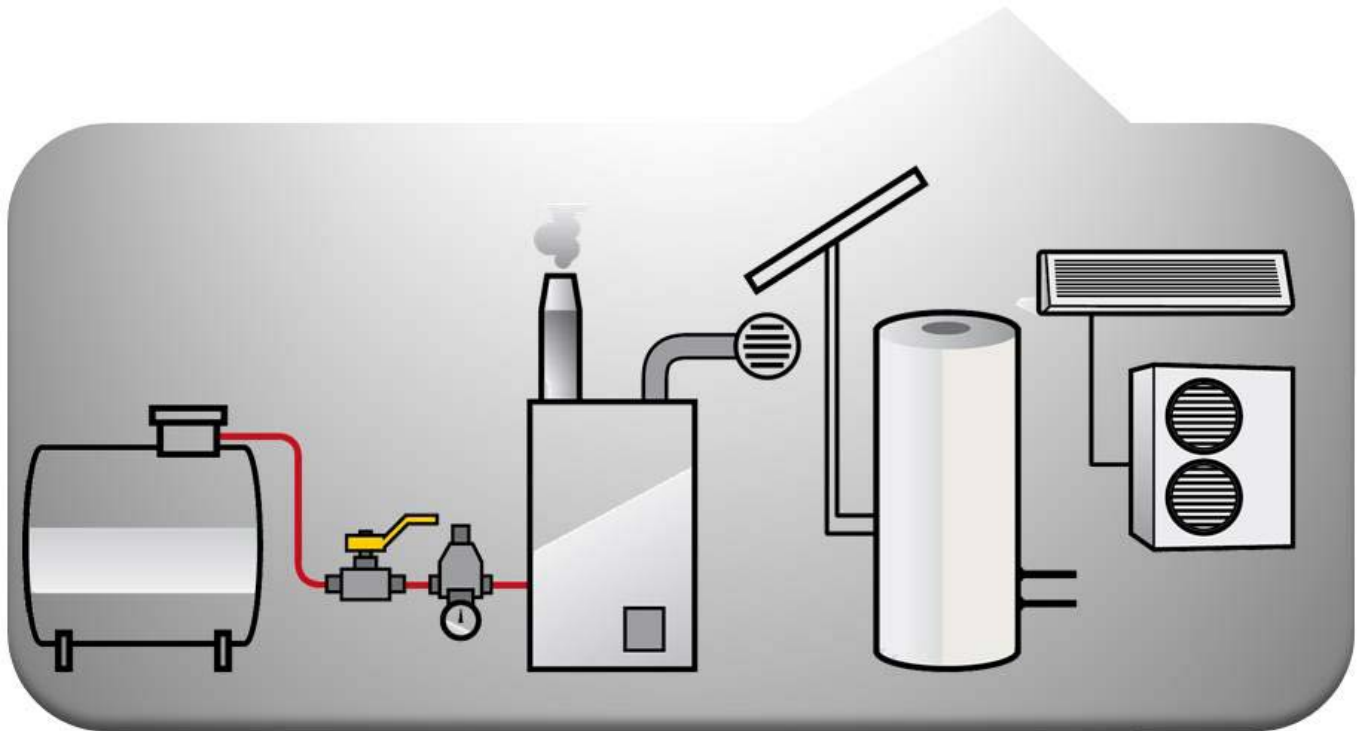

Installation times are DRASTICALLY REDUCED, all to the benefit of a QUALITY, SAFE RESULT.

Air renewal ELFOFresh²

Energy-recovery based room ventilation and purification

- Active thermodynamic summer and winter recovery
- Fulfill up to 80% of the building thermal load
- Electronic filtration: PM10, bacteria, pollen
- Summer humidification, ideal to be combined with radiant cooling
- FREE-COOLING

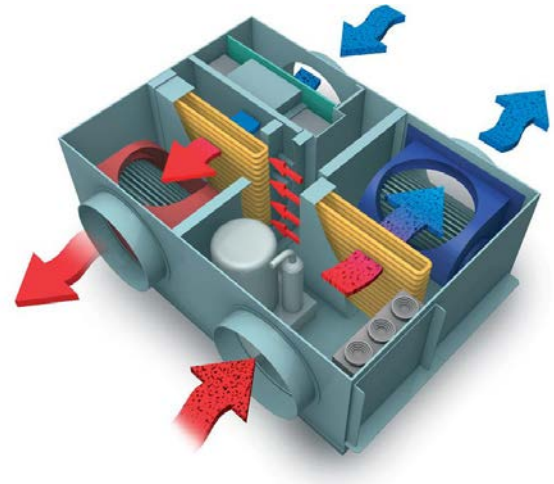

ELFOControl² control

Advanced control system to manage the operation of the entire system

- High seasonal efficiency thanks to the control over the entire system
- Optimization of units efficiency and operation
- Improved comfort (temperature, humidity, quality of the air, domestic hot water)
- Simply to use and complete system management

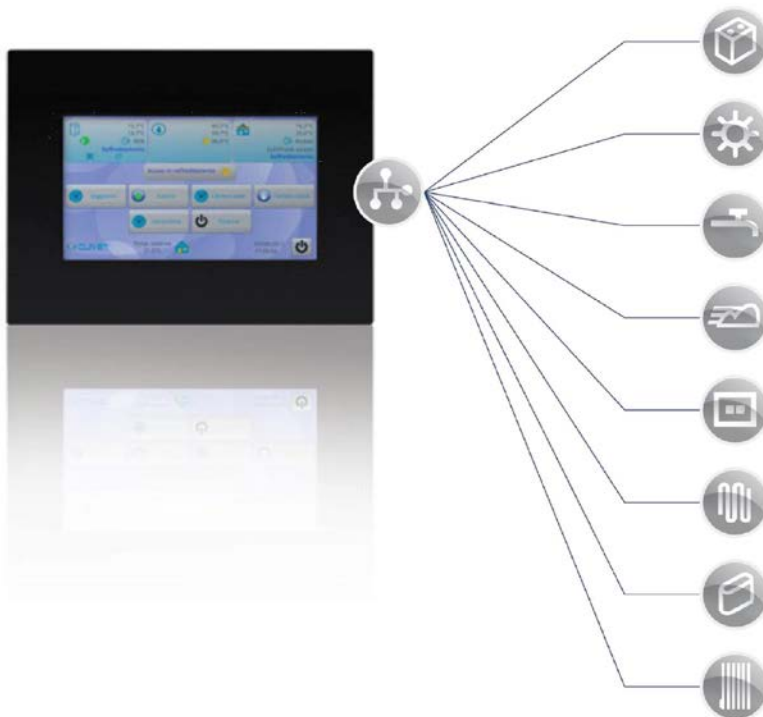

It optimises heating and cooling with GAIA

It uses the contribution of thermal solar sources to produce DHW

It guarantees the availability of domestic hot water

It freshens and purifies air with ELFOFresh²

Interacts with the thermostats of the various rooms to control the temperature and humidity

It manages the radiant panels

It manages the room terminals

It manages radiators and heating furniture

Distribution ELFODistribution

Heat diffusion systems with "room by room" temperature adjustment

- Temperature and humidity thermostats room by room
- Dedicated water terminals

compact design and small size

continuous speed variation

evenly distributed temperature

reduced consumption

- Management of radiant systems and radiators



ELFORoom²

The room terminal which generates the highest comfort

ELFORoom² is the clever combination of design and technology that allows to achieve high comfort standards that are better than any other emission system. It is the ideal solution for renovation works: ELFORoom² can be installed to replace the radiator and thanks to the low operating temperatures it allows for consistent savings on running costs and a better quality of the air thanks to the continuous filtering action. As well as heating up, ELFORoom² allows to cool down and dehumidify rooms in summer with a simple solution: insulation for the system's pipes and an adequate condensation drain. It is a valid alternative in new homes: thanks to the low thermal loads required in every room, ELFORoom² allows more advantageous initial installation costs compared with a radiant system, along with the fact that the ambient temperature is reached quickly thanks to the lower thermal inertia.

One single terminal for all seasons

With a single terminal it is possible to heat up in winter, while in summer it allows to cool down and dehumidify rooms. I can have all-year-round comfort with just one terminal. It reaches the desired temperature more quickly and does not take long to heat up rooms.



Homogenous temperature



ELFORoom²'s even temperature: the continuous operation of the fan and its gradual speed change ensure the air is constantly moved. This allows to obtain a perfectly even temperature, thereby preventing stratification. The comfort is further increased thanks to the low air speed, which cannot be perceived by people in the room, thereby allowing to achieve high comfort levels.

Silence

ELFORoom² is fitted with a tangential fan operated by a special motor whose continuous operation allows to always operate a very low speeds, making it extremely silent. It employs high ventilation speed only to reach the comfort temperature in the room more quickly. ELFORoom²'s advanced control system allows to constantly adjust the fan's speed to the required thermal demand.



Air purification

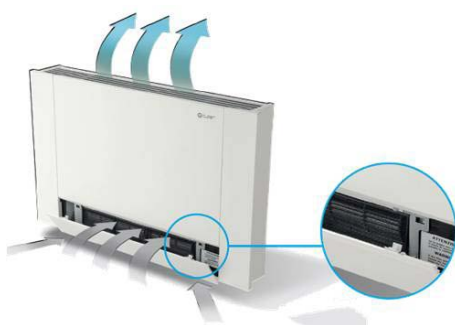

ELFORoom² combines a complete and flexible temperature control with a focus on the quality of the air. The fact that the air is constantly moved allows to continuously purify it and remove the dust contained in it. The system to access the filter has been specifically designed to ensure cleaning operations can be carried out easily and quickly directly by the end user.

Reduced consumptions

The exclusive electric DC motor of ELFORoom²'s fan ensures reduced consumption as the ventilation can be modulated. The high efficiency levels of its innovative technological solution noticeably limits the energy required to operate it correctly, thereby reducing the power used and running costs compared with traditional fan-coils. Compared with a traditional fan-coil, it is possible to achieve savings of about 40% in terms of electricity and 60% in terms of absolute power.

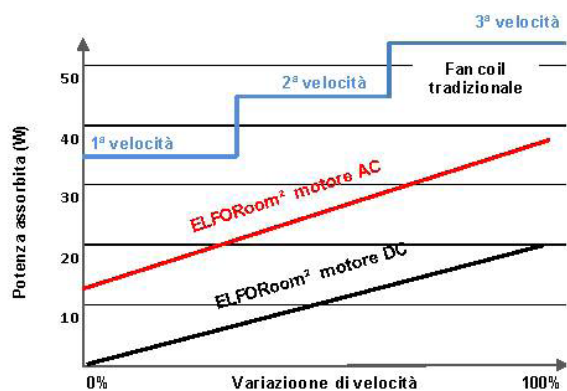

It adapts elegantly to any type of room



The simple design and reduced size make ELFORoom2 the room terminal suited to any kind of interiors.

The solid structure, entirely made up of metal components, makes it indestructible and comparable to a radiator.

Reduced thickness

A thickness of only 13 cm makes it extremely suitable for residential settings when compared to traditional fan coils which usually have a thickness of 22 cm.

Easy to clean

Flat surfaces and materials allow to easily and quickly clean the external casing. The air filter can be easily cleaned by anyone, as the front intake grille can be opened with a simple touch of a finger.

Satisfies all installations

ELFORoom² is a room terminal that can be installed in any architectural setting as it comes with both a vertical uncased and built-in wall version and a horizontal uncased and built-in ceiling version.

A full range of accessories – such as the feet used for floor installation, the supply and intake plenums, the formwork for built-in installation and many other accessories – make ELFORoom² a complete system to meet a number of installation solutions.



Vertical cased installation



Vertical uncased installation



Uncased horizontal installation



Built-in horizontal

Control functions

Vertical cased ELFORoom² with built-in thermostat

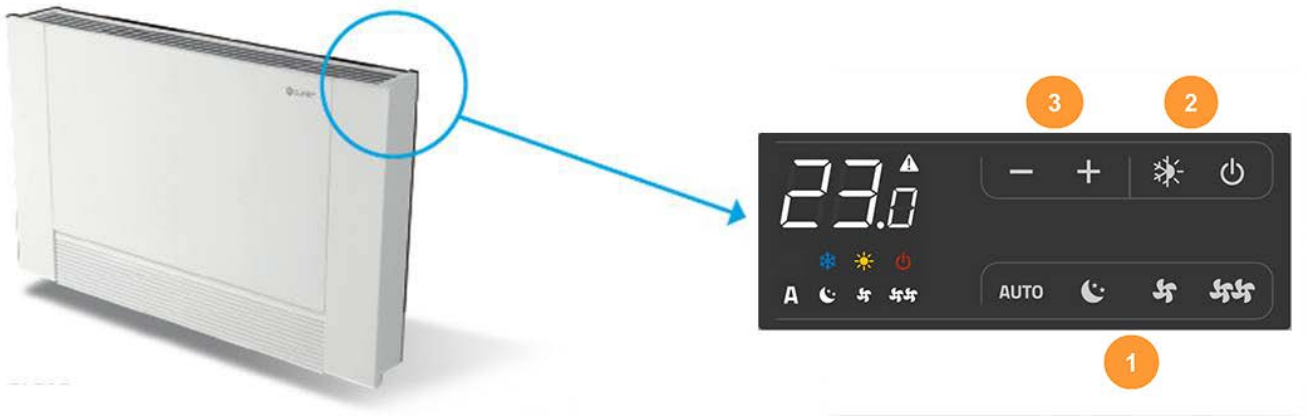

The control board and the independent keypad on the unit, installed in uncased vertical versions, make the terminal fully autonomous thanks to the following functions.

The on-board thermostat is already designed to be connected to ELFOControl².

1

Auto

The AUTO function automatically adjusts the ventilation speed in relation to the thermal demand. The unit is programmed by the manufacturer with the AUTO mode enabled;

Night mode:

The night mode limits the fan to the minimum speed and the set-point is reduced by 1°C and a further degree after 2 hours from the switching on;

Maximum speed:

This control forces the fan to operate at minimum speed;

Minimum speed:

This control forces the fan to operate at top speed. If the water temperature is above 20°C in summer and below 30°C in winter, the fan is not activated and the summer/winter symbol will flash on the thermostat. If the reference temperatures are not reached within 10 minutes from when the terminal is turned on, the terminal is automatically set to stand-by. The unit is restarted automatically after 45 minutes from the block or manually by switching from the summer to the winter mode or vice versa;

2

ON/OFF button

By holding it down for 5 seconds the unit is switched off and on, pressing it down with just one click, it moves the selection of various options from left to right;

Key to select the summer-winter mode:

The function is set to manually by the manufacturer. By pressing and holding the key for 10 seconds until the summer/winter symbol simultaneously turns on, it is possible to set the summer-winter mode. Carry out the procedure in reverse order to go back to the manual adjustment until the symbol turns off.

3

Temperature control keys:

The setpoint can be selected within a range from 16°C to 28°C and with keys 2

Vertical-horizontal cased ELFORoom² without built-in thermostat

The following units are supplied with a lateral electronic board that allows to control the fan and any other accessories and can be connected to the following thermostats: wall-mounted HID-T2, HID-T3 or HID-Ti2. Their features are described in the following pages of this document.

The HID wall thermostat can control from 1 to 9 ELFORoom² units in a Master-Slave configuration (mini networks). Although the units are controlled by the wall thermostat, they have a keyboard on the unit with an on/off control and a warning LED.

The on-board thermostat is already designed to be connected to ELFOControl².



Ambient control

Electronic ambient control for wall or built-in installation with temperature-only sensor or temperature and humidity sensor

ELFOControl²: the centralized Clivet control

Example of possible installations

ELFOControl² is the innovative control developed by Clivet to manage comfort in residential environments. It optimises the operation of all the ELFOSystem elements connected to it (ELFOEnergy heat pump, ELFOFresh², heat distribution systems) to achieve maximum comfort and energy savings. ELFORoom² is designed for the RS485 serial connection and be connected to ELFOControl².



Unit technical features

Structure

Load-bearing structure made of highly resistant electro-zinc coated sheet parts

Panelling

External panelling of the unit in painted sheet metal, matt RAL 9003 finish with plastic (UL V0 flame-retardant) components. Where necessary, the panels can be removed to be able to fully access internal components

Air exchanger

Thermal exchange coil featuring copper pipes and aluminium finned coils with a highly efficient device that generates turbulence. Eurokonus 3/4 threaded fittings that ensure tightness without the addition of other elements (hemp, gaskets, Teflon, liquid sealants, etc.) thanks to an O-ring gasket placed directly on the female fitting. The gasket can ensure tightness as it fits perfectly with a special countersink on the male fitting.

The coil is fitted with a sensor to detect the temperature of the water, which allows to activate the ventilation only if the water is less than 20°C in cooling mode and above 30°C in heating mode

Fan

Tangential fan made of synthetic material with staggered blades (high-level of silence) assembled on vibration-proof EPDM supports.

Supply air grille reversible

Made with painted grey aluminium with oven-dried epoxy powder. The supply grille can be rotated to divert the air flow towards the room or towards the wall

Intake grille

Made with white electro-galvanised painted sheet metal with oven-dried epoxy powder (RAL9003) with a quick-release device to clean the filter and safety microswitch.

Electrical motor

Brushless DC motor with variable speed mounted on EPDM antivibration supports

Filtration

NAN net filter made with honeycomb multilayered polypropylene fabric (weight efficiency A, gravimetric determination 48%).

Tray

Removable shock-proof PVC tray for periodical cleaning

Electrical panel

The electrical panel, consisting of a microprocessor control, is located inside the unit and can be accessed via a panel which can be easily removed.

Uncased ELFORoom² with on-board thermostat makes it completely independent the terminal since it allows selecting, using 8 touch buttons and a backlit LCD, fan speeds, the ON/OFF, the adjusting of the desired temperature and the selection of cool or heat mode.

ELFORoom², uncased and built-in for installation with a wall thermostat (HID), has a electronic board with an LED to report alarms.

Here below are the wall thermostats (HID) that can be connected to the terminals:

- HID-T2 - wall room thermostat with temperature probe
- HID-Ti2 - built-in wall room thermostat with temperature probe
- HID-T3 - wall room thermostat with temperature and humidity probe

All standard ELFORoom² configurations have:

- due outputs to control a cooling and heating generator
- Remote ON-OFF
- serial board for the network connection to be integrated with ELFOControl² or an HID wall thermostat that manages up to 9 units.

Connections

The standard unit is fitted with connections on the left-hand side. The water connections to the coil are 3/4" EUROKONUS connections and there are 3/4" flat adapters. The size of the condensation drain is 14 mm. If the coil is rotated for the connections on the right-hand side, it is necessary to use the motor connection kit for units with connections on the right-hand side.

Accessories

Standard accessories supplied separately and available in stock:

- KCMDX - Motor connection cables for units with connections on the right-hand side.
- KV3VBX - 3-way valve kit with electrothermal head and balancing for the 2-pipe version
- KV3B4X - 3-way valve kit with electrothermal head and balancing for a 4-pipe system
- KPDX - Feet Kit
- BACKV - Rear painted panel for cased unit
- FXPPX - Floor fixing brackets kit
- PMSTX - Upper telescopic supply plenum kit
- KASPX - Intake plenum kit
- PR90MX - 90° supply plenum kit
- GMX - Supply grille
- GRA1X - Air outflow grille
- CSFIX - Formwork for built-in installation
- PCIX - Built-in closing panel
- HID-T2X - HID-T2 electronic room control
- HIDTI2X - HID-TI2 flush-mounted electronic room control
- HID-T3X - Electronic room control device HID-T3
- HID-E1X - Remote control with 3 position switch + on/off for wall installation
- HID-E2X - Remote control with E/I+3V+ on/off for wall installation
- HID-E3X - Plurifunctional remote control for wall installation

Unit configuration

Required for the full supply with the variants reported below

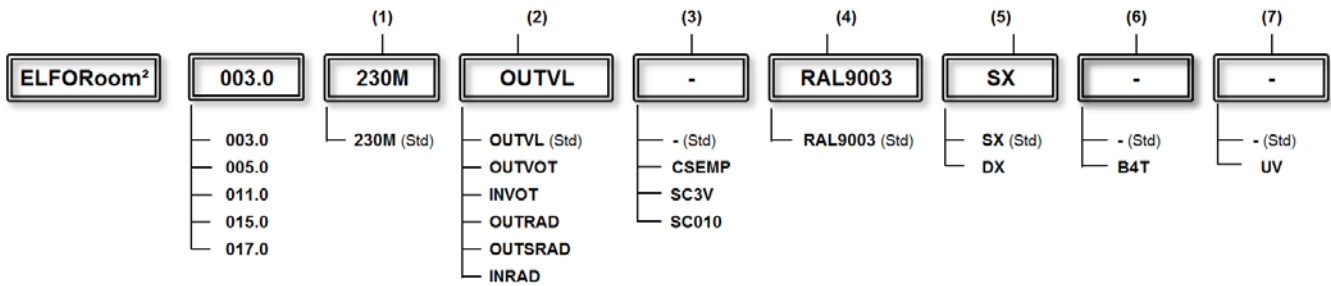

(1) Supply voltage

230M Supply voltage 230/1/50 (standard)

(2) Configurations

- OUTVL Vertical cased with LCD display, continuous modulation DC motor, RS485 interface and built-in thermostat (standard)
 - OUTVOT Vertical - Horizontal cased with continuous modulation DC motor, RS485 interface without built-in thermostat
 - INVOT Vertical - Horizontal uncased with continuous modulation DC motor, RS485 interface without built-in thermostat
 - OUTRAD Vertical cased with continuous modulation DC motor, RS485 interface with built-in thermostat and ventilated radiant plate
 - OUTSRAD Vertical cased with continuous modulation DC motor, RS485 interface, without built-in thermostat and with ventilated radiant plate
 - INRAD Vertical uncased with continuous modulation DC motor, RS485 interface, without built-in thermostat and with ventilated radiant plate
- Note: with the INRAD configuration you must also select the CSFIX (formwork) and PCIX (built-in closing panel) option.

(3) Aesthetic finishing

RAL 9003 Aesthetic finishing: RAL 9003 painting opaque (standard)

(4) Water connections

- SX Water fittings to the left (standard)
- DX Water fittings to the right

(5) Hot water coil

- Not required (Standard)
- BAT Additional coil for 4-pipe syst.

(6) Special accessories

- Not required (Standard)
- UV UV germicidal lamp kit with support

(7) Electronics version

- Standard electronic version
- CSEMP Simplified electronic control with 4 speeds DC motor, built-in thermostat without RS485 interface
- SC3V DC motor modulation electronic board for matching to 3 speeds thermostats
- SC010 DC motor modulation electronic board for matching to 0-10V thermostats

General technical data

Size			003.0	005.0	011.0	015.0	017.0
Cooling							
Cooling capacity	1	kW	0.89	1.91	2.83	3.69	4.19
Sensible capacity	1	kW	0.65	1.29	1.94	2.50	2.78
Total power input	1	kW	0.012	0.02	0.022	0.03	0.033
Heating							
Heating capacity	2	kW	0.93	1.97	2.71	3.45	4.11
Internal exchanger							
Water content		l	0.47	0.80	1.13	1.46	1.80
Water flow-rate	1	l/s	0.040	0.084	0.126	0.16	0.182
Pressure drop	1	kPa	7.2	8.4	22.5	18.6	24.9
Air Handling Section Fans (Supply)							
Type of supply fan	3		TGZ	TGZ	TGZ	TGZ	TGZ
Supply airflow	4	l/s	45	89	128	160	180
CONNECTIONS							
Water fittings			Eurokonus M 3/4	Eurokonus M 3/4	Eurokonus M 3/4	Eurokonus M 3/4	Eurokonus M 3/4
Condensate drain			14	14	14	14	14
Power supply							
Standard power supply	5	V	230/1/50	230/1/50	230/1/50	230/1/50	230/1/50

1. Ambient air at 27°C/19.5 W.B., inlet water 7°C and outlet at 12°C
2. ambient air at 20°C D.B., inlet water at 45°C and outlet at 40°C
3. TGZ=tangential

4. Air flow at max speed measured with clean filters
5. power supply 230/1/50 Hz +/-10%

Electrical date

Supply voltage 230/1/50

Size			003.0	005.0	011.0	015.0	017.0
F.L.A. - Full load current at max admissible conditions							
F.L.A. - Total		A	0.11	0.16	0.18	0.26	0.28
F.L.I. - Full load power input at max admissible conditions							
F.L.I. - Total		kW	0.012	0.02	0.022	0.03	0.033

power supply 230/1/50 Hz +/-10%

Sound levels

Low speed (L)

Size	Sound power level (dB)								Sound power level	Sound pressure level
	Octave band (Hz)									
	63	125	250	500	1000	2000	4000	8000		
003.0	49	49	34	33	27	22	22	23	36	23
005.0	45	45	39	39	22	27	23	23	40	26
011.0	46	46	39	41	35	28	23	23	41	27
015.0	35	35	38	35	34	22	19	22	37	23
017.0	45	45	39	38	33	25	20	23	39	27

Medium speed (M)

Size	Sound power level (dB)								Sound power level	Sound pressure level
	Octave band (Hz)									
	63	125	250	500	1000	2000	4000	8000		
003.0	50	50	45	43	41	35	28	24	45	32
005.0	45	45	45	45	42	36	29	24	46	32
011.0	49	49	44	46	43	37	30	24	47	33
015.0	38	38	43	43	40	34	27	25	44	30
017.0	47	47	46	46	44	38	31	25	48	37

High speed (H)

Size	Sound power level (dB)								Sound power level	Sound pressure level
	Octave band (Hz)									
	63	125	250	500	1000	2000	4000	8000		
003.0	51	51	47	49	48	43	37	27	52	39
005.0	45	45	48	50	51	45	38	28	53	40
011.0	51	51	48	49	50	45	38	28	53	39
015.0	47	47	49	48	51	44	37	28	53	39
017.0	52	52	50	49	52	45	39	29	54	43

The values have been detected in a closed ambient with a volume of 100 m³ and a reverberation time of 0.5 seconds.

The noise levels refer to units at full load under nominal test conditions.

The medium spressure level are referred to unit operating at 1 m from the external unit surface, with fairing, fitted to a wall.

Installing the unit at the different conditions from the nominal ones (e.g. near walls or obstacles generally)The sound levels may undergo significant variations.

Operating range

Operating Range (Cooling)

Size			003.0	005.0	011.0	015.0	017.0
Internal exchanger							
Max inlet water temperature		°C	80	80	80	80	80
Min. water inlet temperature		°C	30	30	30	30	30
Min. entering air temperature (D.B.)		°C	5	5	5	5	5
Maximum water side pressure		bar	10	10	10	10	10

Operating Range (Heating)

Size			003.0	005.0	011.0	015.0	017.0
Internal exchanger							
Max inlet water temperature		°C	20	20	20	20	20
Min. water inlet temperature		°C	4	4	4	4	4
Max entering air temperature (WB)		°C	32	32	32	32	32
Min inlet air temperature (W.B.)		°C	5	5	5	5	5
Maximum water side pressure		bar	10	10	10	10	10

Water side pressure drops

Cooling)

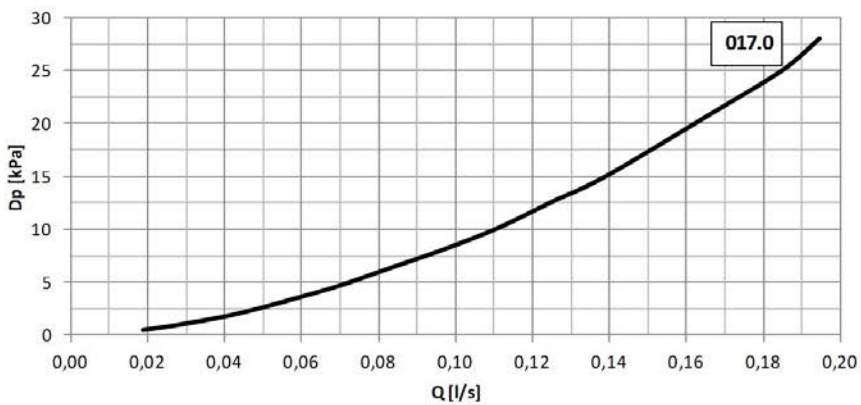
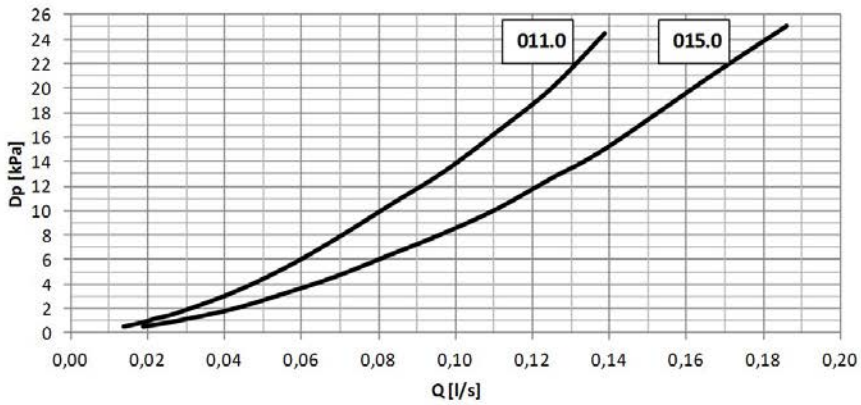
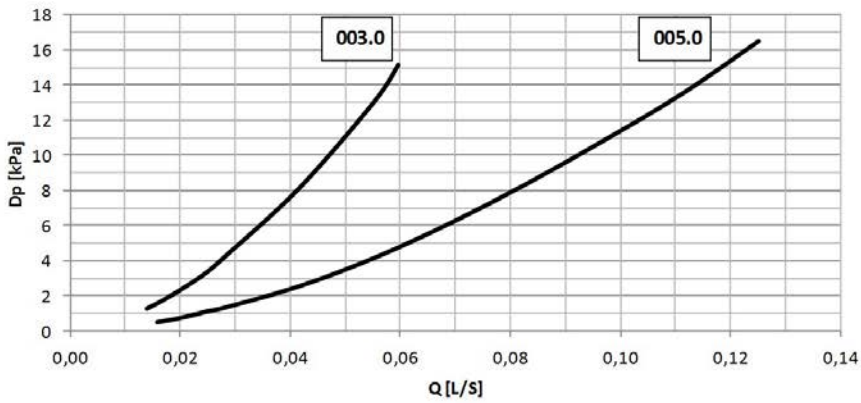

DP = pressure drop [kPa]

Q = water flow rate[l/s]

Heating

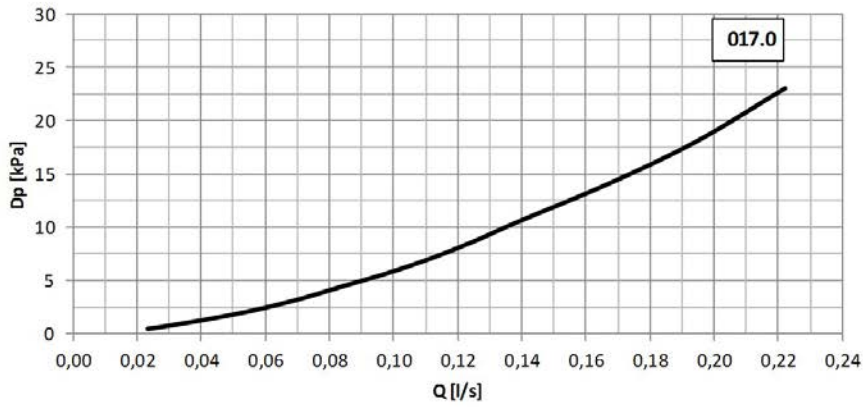
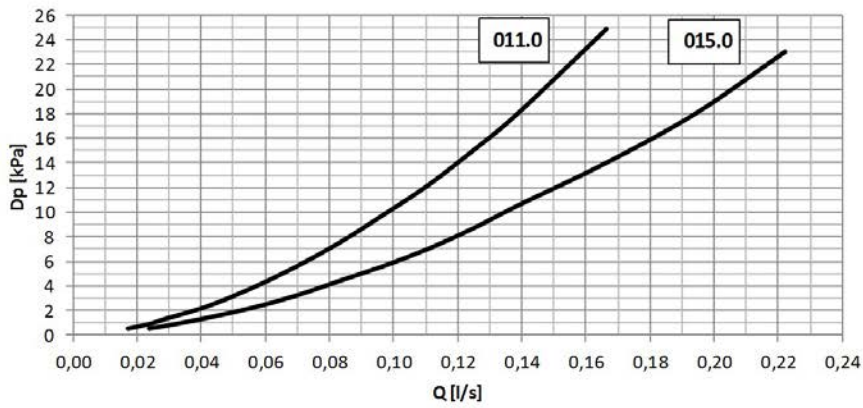
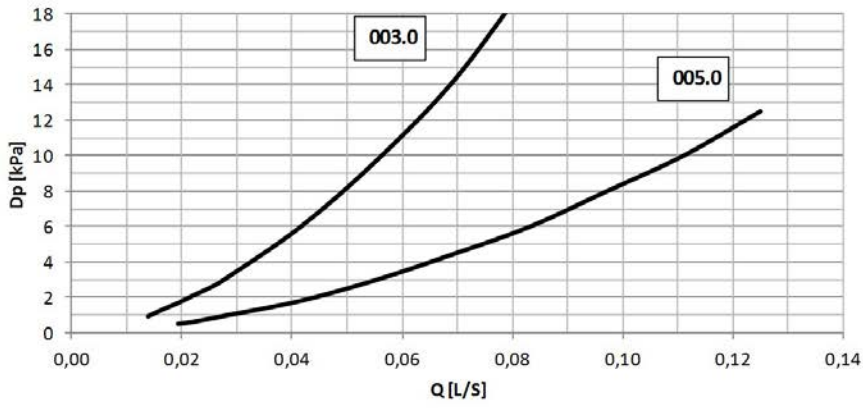

DP = pressure drop [kPa]

Q = water flow rate[l/s]

Performances in cooling

Size	Ta (°C) DB/WB	Exchanger water inlet / outlet temperature (°C)									
		5/10		7/12		10/15		13/18		15/20	
		kWf	kWs	kWf	kWs	kWf	kWs	kWf	kWs	kWf	kWs
003.0	22 / 15,4	0,38	0,44	0,23	0,37	0,17	0,17	0,16	0,16	0,11	0,11
	24 / 17	0,68	0,57	0,49	0,48	0,32	0,32	0,29	0,29	0,17	0,17
	26 / 18,6	0,99	0,69	0,74	0,59	0,47	0,47	0,42	0,42	0,23	0,23
	27 / 19,5	1,11	0,74	0,89	0,65	0,58	0,53	0,51	0,48	0,26	0,26
	28 / 20,3	1,24	0,79	1,02	0,70	0,70	0,57	0,62	0,52	0,32	0,32
	30 / 21,9	1,49	0,88	1,29	0,80	0,94	0,66	0,85	0,62	0,46	0,46
005.0	22 / 15,4	1,30	1,06	0,91	0,89	0,71	0,81	0,61	0,69	0,21	0,21
	24 / 17	1,68	1,22	1,31	1,05	0,93	0,90	0,83	0,81	0,43	0,43
	26 / 18,6	2,06	1,37	1,71	1,22	1,14	0,99	1,04	0,92	0,66	0,66
	27 / 19,5	2,25	1,45	1,91	1,29	1,33	1,05	1,21	0,99	0,75	0,75
	28 / 20,3	2,46	1,52	2,11	1,37	1,54	1,13	1,40	1,06	0,83	0,81
	30 / 21,9	2,87	1,67	2,52	1,52	1,97	1,29	1,78	1,22	1,01	0,94
011.0	22 / 15,4	1,84	1,56	1,22	1,28	0,99	1,14	0,81	0,93	0,10	0,10
	24 / 17	2,45	1,81	1,86	1,55	1,31	1,31	1,15	1,15	0,51	0,51
	26 / 18,6	3,07	2,07	2,51	1,82	1,63	1,49	1,49	1,37	0,91	0,91
	27 / 19,5	3,38	2,19	2,83	1,94	1,89	1,55	1,73	1,46	1,09	1,09
	28 / 20,3	3,70	2,30	3,15	2,06	2,24	1,68	2,04	1,59	1,22	1,20
	30 / 21,9	4,33	2,54	3,80	2,30	2,94	1,94	2,65	1,84	1,50	1,44
015.0	22 / 15,4	2,31	1,94	1,40	1,54	1,24	1,36	1,07	1,17	0,43	0,43
	24 / 17	3,15	2,29	2,33	1,92	1,55	1,55	1,37	1,37	0,65	0,65
	26 / 18,6	3,98	2,64	3,25	2,31	1,87	1,74	1,67	1,57	0,88	0,88
	27 / 19,5	4,40	2,81	3,69	2,50	2,41	1,94	2,18	1,80	1,25	1,25
	28 / 20,3	4,83	2,97	4,13	2,66	2,90	2,12	2,61	1,98	1,45	1,42
	30 / 21,9	5,70	3,29	5,02	2,98	3,87	2,49	3,47	2,35	1,86	1,78
017.0	22 / 15,4	2,75	2,22	1,88	1,83	1,26	1,56	1,05	1,29	0,24	0,24
	24 / 17	3,63	2,59	2,81	2,21	1,80	1,78	1,59	1,58	0,76	0,76
	26 / 18,6	4,51	2,96	3,73	2,60	2,35	2,01	2,14	1,86	1,29	1,29
	27 / 19,5	4,96	3,13	4,19	2,78	2,88	2,21	2,60	2,07	1,51	1,51
	28 / 20,3	5,42	3,31	4,67	2,96	3,38	2,40	3,04	2,26	1,70	1,67
	30 / 21,9	6,35	3,66	5,61	3,31	4,39	2,78	3,93	2,62	2,09	1,98

Ta = air intake temperature

DB = dry bulb

WB = wet bulb

kWf = Cooling capacity in kW

kWs = sensible cooling capacity (kW)

Water temperature differential = 5°C

Performance values refer to the maximum air flow rate

Performance in Heating

Size	Exchanger water inlet / outlet temperature (°C)					
	Twi (°C)	35/30	40/35	45/40	50/45	60/55
		kWt	kWt	kWt	kWt	kWt
003.0	10	0,94	1,16	1,38	1,59	2,02
	15	0,72	0,94	1,15	1,37	1,79
	18	0,58	0,81	1,02	1,23	1,66
	20	0,49	0,72	0,93	1,14	1,57
	22	0,39	627,00	0,85	1,06	1,48
	25	0,18	0,49	0,72	0,93	1,35
005.0	10	2,00	2,45	2,91	3,36	4,26
	15	1,53	1,99	2,44	2,89	3,78
	18	1,24	1,71	2,16	2,60	3,49
	20	1,05	1,54	1,97	2,42	3,30
	22	0,84	1,34	1,79	2,23	3,11
	25	0,39	1,05	1,52	1,96	2,84
011.0	10	2,75	3,37	3,99	4,60	5,84
	15	2,11	2,73	3,35	3,96	5,18
	18	1,74	2,35	2,96	3,57	4,79
	20	1,48	2,10	2,71	3,32	4,53
	22	1,21	1,86	2,46	3,07	4,27
	25	0,79	1,48	2,09	2,69	3,89
015.0	10	3,50	4,29	5,07	5,85	7,41
	15	2,69	3,48	4,26	5,03	6,57
	18	2,21	3,00	3,77	4,54	6,07
	20	1,88	2,68	3,45	4,22	5,75
	22	1,54	2,36	3,14	3,90	5,42
	25	0,97	1,88	2,67	3,43	4,94
017.0	10	4,18	5,11	6,04	6,97	8,83
	15	3,20	4,15	5,07	5,99	7,83
	18	2,62	3,57	4,49	5,41	7,23
	20	2,22	3,19	4,11	5,02	6,84
	22	1,81	2,81	3,74	4,64	6,45
	25	1,59	2,23	3,17	4,08	5,88

Data based on the rated water flow rate

Ta = air intake temperature

kWt = Provided heating capacity (kW)

Water temperature differential = 5°C

Performance values refer to the maximum air flow rate

Static heating performance

Size	HEATING	
	Twi (°C)	Pt
		kW
003.0	35	0,13
	40	0,22
	45	0,27
	50	0,32
	60	0,43
	70	0,55
	80	0,66
005.0	35	0,21
	40	0,25
	45	0,32
	50	0,38
	60	0,5
	70	0,67
	80	0,8
011.0	35	0,25
	40	0,31
	45	0,38
	50	0,46
	60	0,61
	70	0,79
	80	0,94
015.0	35	0,28
	40	0,37
	45	0,46
	50	0,55
	60	0,730
	70	0,920
	80	1,1
017.0	35	0,330
	40	0,440
	45	0,550
	50	0,660
	60	0,880
	70	1,080
	80	1,300

Data based on the rated water flow rate

Twi = inlet water temperature (°C)

Ta = ambient air temperature 20°C

Pt = delivered heating capacity(kW)

Note:

Static heating performances occur when water passes through the terminal and the main ventilation is off.

Cooling capacity corrective coefficient as a function of the water flow rate

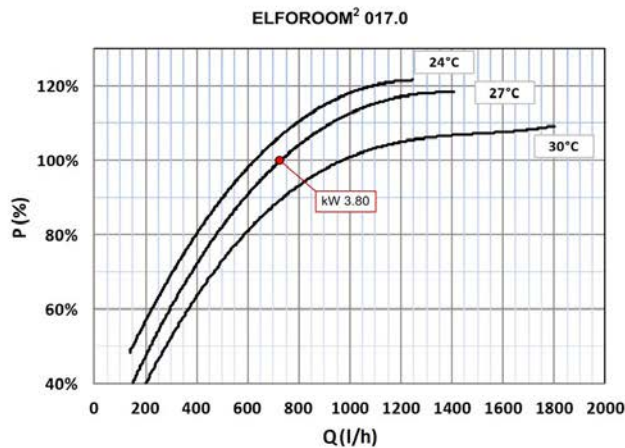
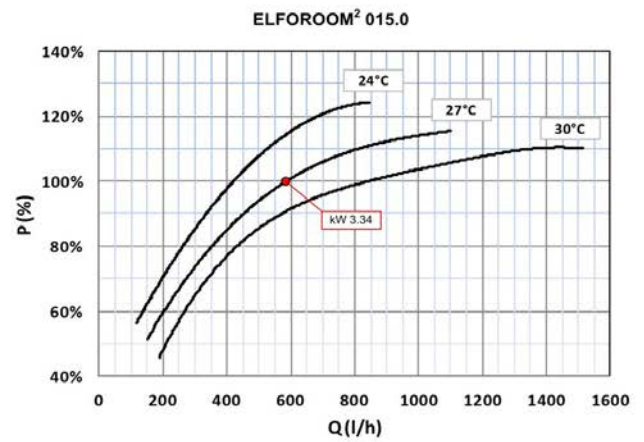
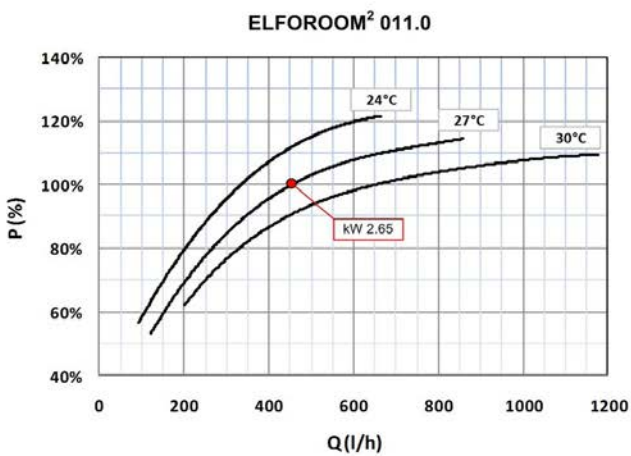
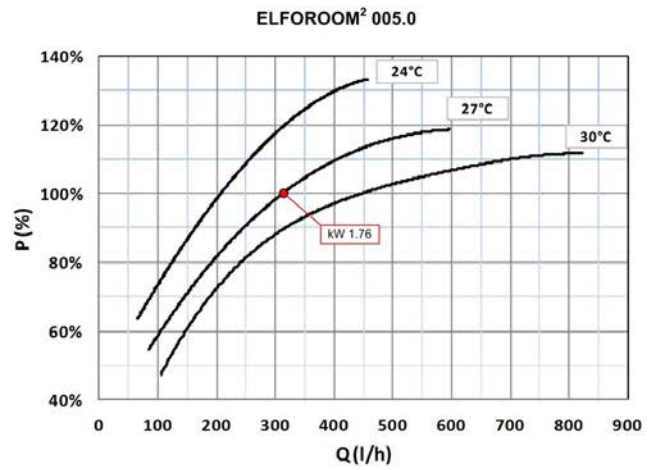
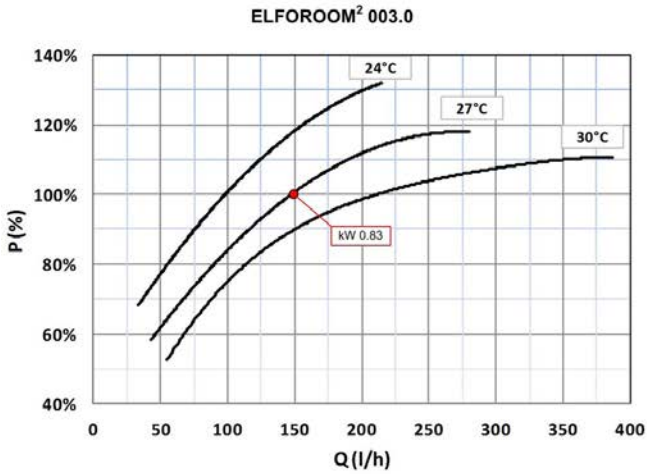

Data referred to the following conditions:

Max fan speed

kW = delivered capacity(kW)

(P)performance percentages compared with the unit's rated capacity

(Q)Water flow rate(l/h)

Ambient air at 27°C D.B./19.5°C W.B.

Water inlet 7° and outlet 12°C

Heating capacity corrective coefficient as a function of the water flow rate

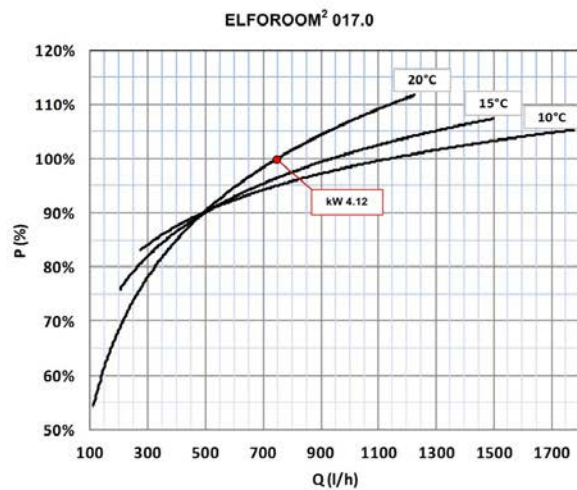
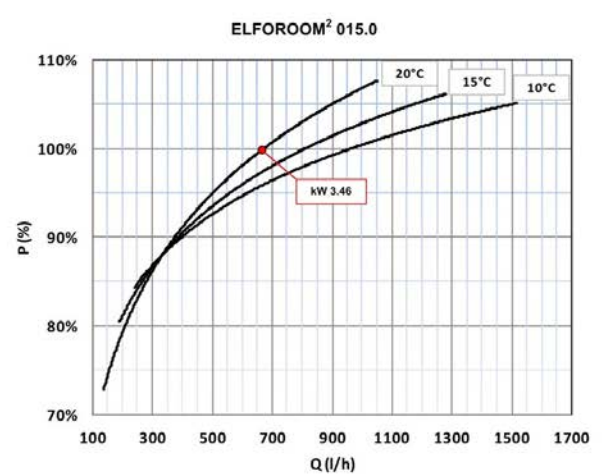
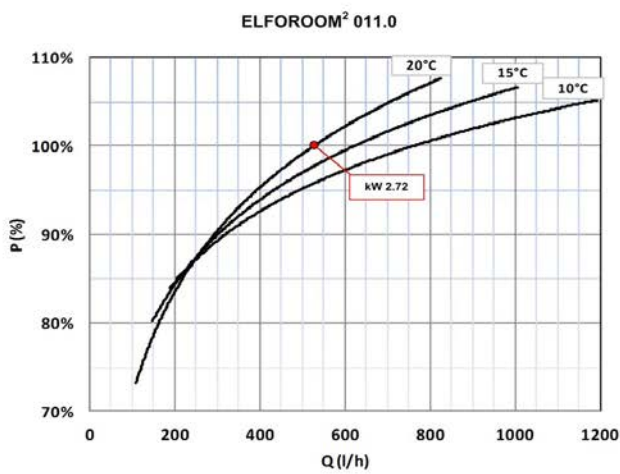
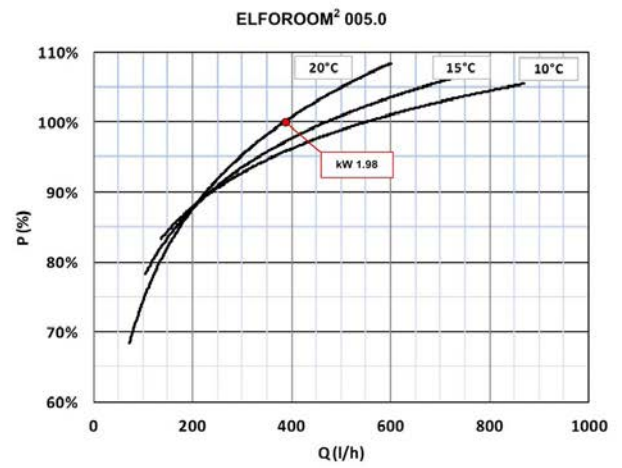
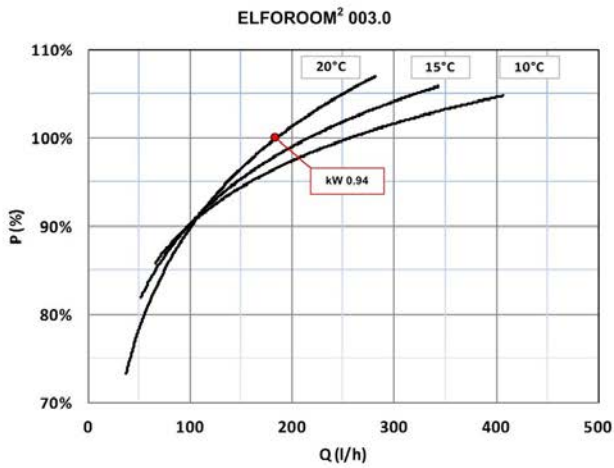

Data referred to the following conditions:

Max fan speed

kW = delivered capacity(kW)

(P)performance percentages compared with the unit's rated capacity

(Q)Water flow rate(l/h)

Ambient air at 20°C D.B. Inlet water at 45°C

Correction factors of cooling efficiency as a function of the air flow rate

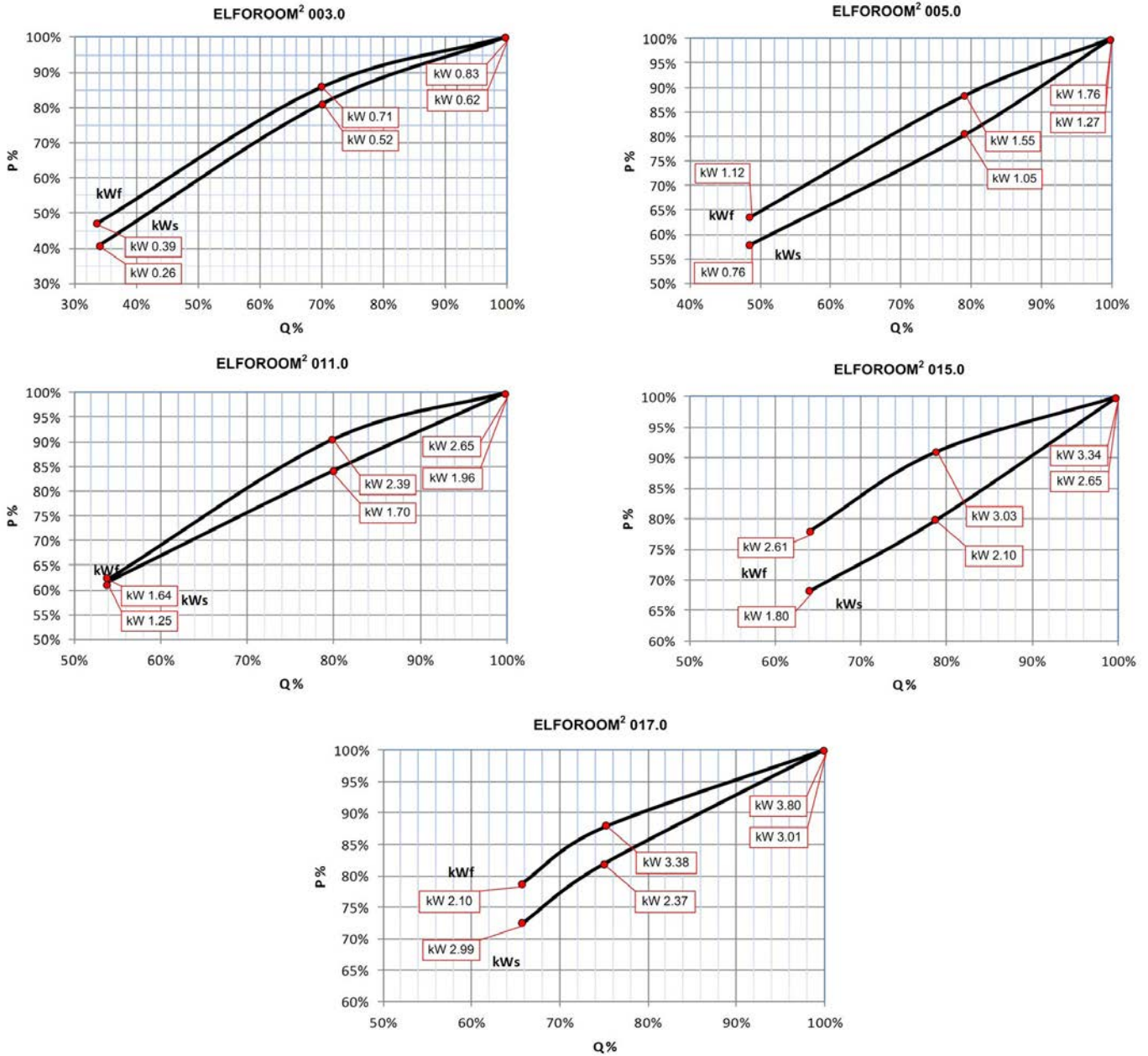

Data referred to the following conditions:

kWf = Cooling capacity in kW

kWs = sensible cooling capacity (kW)

Performance levels reported in the chart refer to water at 7-12°C

(P) performance percentages compared with the unit's rated capacity

(Q) Air flow rate

Absorbed power		003.0	005.0	011.0	015.0	017.0
Maximum speed:	kW	0,012	0,018	0,02	0,027	0,03
Medium speed	kW	0,0081	0,0114	0,0125	0,0164	0,018
Minimum speed:	kW	0,0042	0,0048	0,0051	0,0058	0,006

Correction factors of heating efficiency as a function of the air flow rate

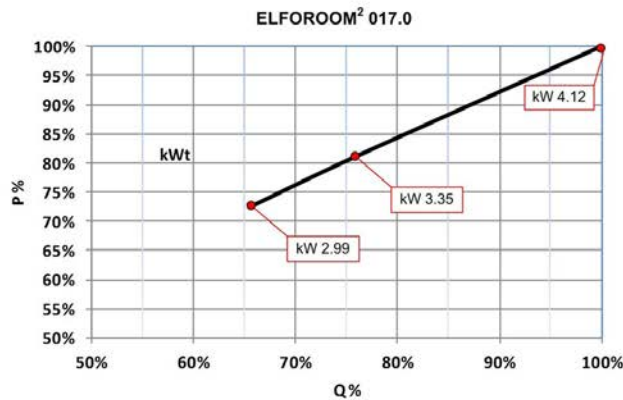
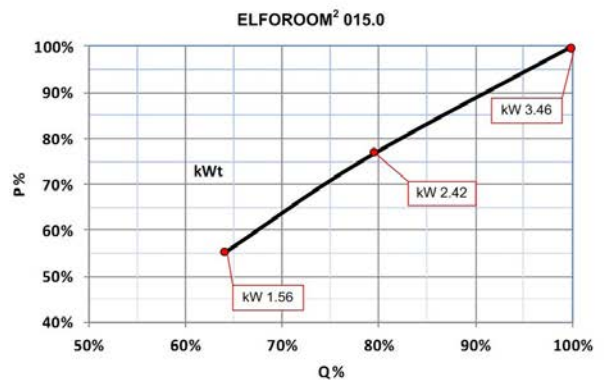
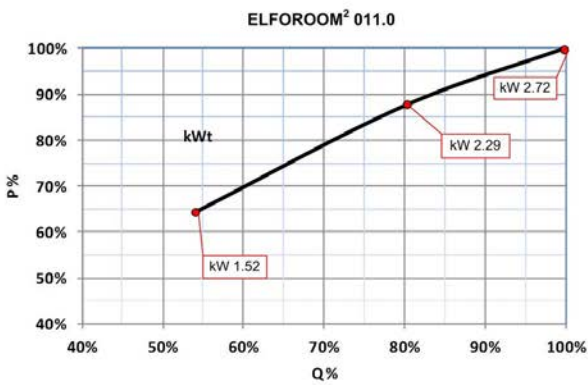
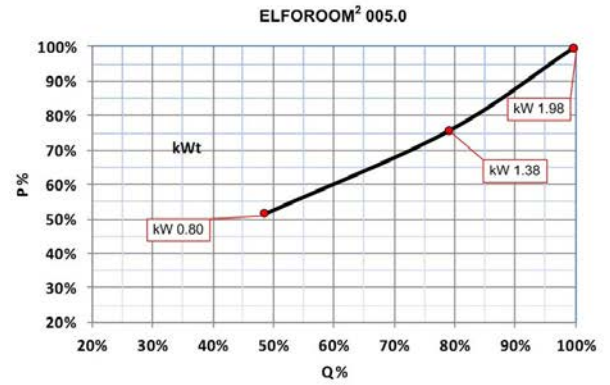
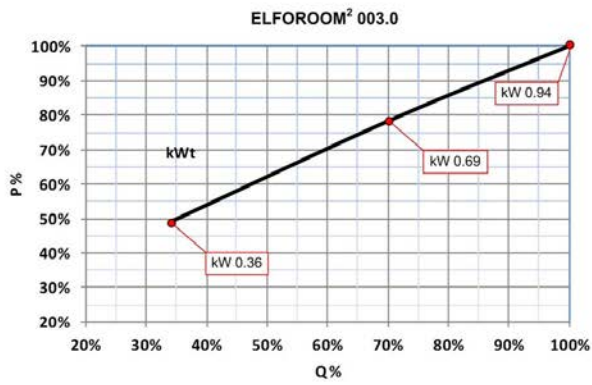

Data referred to the following conditions:

kWt = Provided heating capacity (kW)

Performance levels reported in the chart refer to water at 45-40°C

(P) performance percentages compared with the unit's rated capacity

(Q) Air flow rate

Variation of air flow rate as a function of available pressure for two-pipe systems

MAX SPEED		MED SPEED			MIN SPEED		
SIZE 003.0		SIZE 003.0			SIZE 003.0		
m3/h	Pa	m3/h	% max	Pa	m3/h	% max	Pa
0	20	0		20	0		20
57	15	30	53%	15	0		15
101	10	60	59%	10	21	21%	10
128	5	88	69%	5	36	28%	5
162	0	113	70%	0	55	34%	0
SIZE 005.0		SIZE 005.0			SIZE 005.0		
m3/h	Pa	m3/h	% max	Pa	m3/h	% max	Pa
94	20	0		20	0		20
141	15	90	64%	15	0		15
214	10	162	76%	10	78	36%	10
278	5	215	77%	5	128	46%	5
320	0	252	79%	0	155	48%	0
SIZE 011.0		SIZE 011.0			SIZE 011.0		
m3/h	Pa	m3/h	% max	Pa	m3/h	% max	Pa
166	20	74	45%	20	43	26%	20
254	15	178	70%	15	114	45%	15
330	10	266	81%	10	191	58%	10
417	5	322	77%	5	231	55%	5
461	0	367	80%	0	248	54%	0
SIZE 015.0		SIZE 015.0			SIZE 015.0		
m3/h	Pa	m3/h	% max	Pa	m3/h	% max	Pa
163	20	93	57%	20	0		20
315	15	232	74%	15	102	32%	16
420	10	339	81%	10	239	57%	10
506	5	415	82%	5	320	63%	5
576	0	453	79%	0	370	64%	0
SIZE 017.0		SIZE 017.0			SIZE 017.0		
m3/h	Pa	m3/h	% max	Pa	m3/h	% max	Pa
189	20	112	59%	20	0		20
395	15	258	65%	15	196	50%	15
506	10	385	76%	10	318	63%	10
593	5	450	76%	5	387	65%	5
648	0	494	76%	0	426	66%	0

Variation of air flow rate as a function of available pressure for four-pipe systems

MAX SPEED		MED SPEED			MIN SPEED		
SIZE 003.0		SIZE 003.0			SIZE 003.0		
m3/h	Pa	m3/h	% max	Pa	m3/h	% max	Pa
0	20	0		20	0		20
52	15	27	51%	15	0		15
92	10	53	58%	10	19	21%	10
116	5	78	67%	5	33	28%	5
147	0	101	68%	0	51	34%	0
SIZE 005.0		SIZE 005.0			SIZE 005.0		
m3/h	Pa	m3/h	% max	Pa	m3/h	% max	Pa
85	20	0		20	0		20
127	15	82	64%	15	0		15
193	10	148	76%	10	69	36%	10
251	5	196	78%	5	114	45%	5
289	0	230	79%	0	138	48%	0
SIZE 011.0		SIZE 011.0			SIZE 011.0		
m3/h	Pa	m3/h	% max	Pa	m3/h	% max	Pa
148	20	65	44%	20	37	25%	20
227	15	157	69%	15	99	44%	15
294	10	234	80%	10	166	56%	10
372	5	284	76%	5	201	54%	5
411	0	323	79%	0	215	52%	0
SIZE 015.0		SIZE 015.0			SIZE 015.0		
m3/h	Pa	m3/h	% max	Pa	m3/h	% max	Pa
150	20	84	56%	20	0		20
289	15	209	72%	15	93	32%	15
386	10	305	79%	10	217	56%	10
465	5	374	80%	5	290	62%	5
529	0	408	77%	0	336	63%	0
SIZE 017.0		SIZE 017.0			SIZE 017.0		
m3/h	Pa	m3/h	% max	Pa	m3/h	% max	Pa
176	20	105	60%	20	0		20
367	15	241	66%	15	186	51%	15
470	10	360	77%	10	302	64%	10
551	5	421	76%	5	367	67%	5
602	0	462	77%	0	404	67%	0

Description of electronic equipments

Electronic configuration with on-board thermostat (standard in OUTVL configuration)

The electronic configuration with on-board thermostat makes the terminal fully independent and allows to carry out the functions below:



- Switching the unit on and off
- control of the minimum, maximum automatic and reduced ventilation speed for night-time operation
- set summer and winter mode
- solenoid valves control in heating mode 230/1/50 and in cooling mode for 2-pipe and 4-pipe systems
- ambient temperature detected through a probe on the air return
- water temperature detected with a probe on the inlet water pipe (additional probe for 4-pipe systems)
- control of the minimum inlet water temperature in heating mode and maximum inlet water temperature in cooling mode
- fan switched off if the intake grille with the microswitch is removed
- remote control via a digital on-off device
- starting control for the chiller or the heat pump (1A potential-free contact to be used if Elfocontrol² is not present)
- boiler starting control (1A potential-free contact to be used if Elfocontrol² is not present)

The electronics includes the RS485 Modbus serial port for the connection to Elfocontrol² or supervisors with a Modbus

The control has an LCD display and a back-lit keypad with 8 touch keys.

In AUTO mode the fan constantly switches between maximum and minimum speed based on a proportional and integrative logic in relation to the difference between the ambient temperature and the set temperature.

In night-time mode the fan speed is set to the minimum speed and the setpoint is reduced by 1°C after 1 hour and 2°C after 2 hours.

With a DIP switch it is possible to set night-time mode operation with the heating mode on without ventilation for natural convection.

When the ventilated radiant plate option is chosen, the heating mode is set in night-time operation by default, with no main ventilation and only the microfans in operation.

Electronics arranged for connection to remote thermostat (standard in OUTVOT, INVOT, OUTSRAD and INRAD configurations)

The electronic configuration designed to be connected to the remote thermostat is required for horizontal and built-in versions.

It retains the same functions of the version with the on-board thermostat and must be connected to HID-T2, HID-T3 and HID-Ti2 terminals.

HID-T2X - HID-T2 temperature-only electronic room control, wall installation

HID-Ti2X - HID-Ti2 temperature-only electronic room control, built-in installation

HID-T3X- HID-T3 electronic temperature and humidity room control, wall installation

Although the units are controlled by the wall thermostat, they have a electronic board with an LED to report the unit is in operation or if there is an alarm.

Electronics include the RS485 Modbus serial port for the connection to Elfocontrol² or supervisors with Modbus and allow to create mini networks (a single HID thermostat that controls up to 9 units)



HID-T2, HID-T3 wall thermostat



HID-Ti2 wall thermostat

Configuration options

CSEMP - Simplified electronic control with 4 speeds DC motor, built-in thermostat without RS485 interface

The simplified on-board electronic control for systems with 2 pipes means the room terminal is fully independent, allows to select the speeds, switch the terminal on an off and also has a 230V output to control a solenoid valve.

It includes a thermostat that can be adjusted from 5°C to 30°C, a summer/winter selector and does not have a RS485 Modbus serial board. This is why it cannot be integrated in ELFOControl² systems or mini networks with an HID thermostat



This board can be combined with the ventilated radiant plate option, but not with the auxiliary coil option for systems with 4 pipes.

SC3V - DC motor modulation electronic board for matching to 3 speeds thermostats

The electronic board, without an interface on the unit, allows for the connection to the electromechanical 3-speed thermostats – HID-E1, HID-E2 and HID-E3.

The board features the following functions:

- 4 digital inputs to select the fan speed (max, medium, min and night-time)
- summer-winter switching input
- minimum temperature probe input
- solenoid valve enabling input
- Valve control
- grille microswitch (turns off the fan if the grille is opened)



This board can be combined with HID-E1, HID-E2 and HID-E3 electromechanical thermostats and the ventilated radiant plate option.

The board does not have a RS485 Modbus serial board. This is why it cannot be integrated in Elfocontrol² systems or in mini networks with an HID thermostat.

An opaque panel identical to the one mounted on top of the valve compartment will be mounted on the unit.

SC010 - DC motor modulation electronic board for matching to 0-10V thermostats

The electronic board, without an interface on the unit, allows for the connection to the 0-10V thermostats

The board features the following functions:

- 0/10V fan control input
- solenoid valve enabling input
- Valve control
- grille microswitch (turns off the fan if the grille is opened)

This board can be combined with 0-10V thermostats and the ventilated radiant plate option.

The board does not have a RS485 Modbus serial board. This is why it cannot be integrated in Elfocontrol² systems or in mini networks with an HID thermostat.

An opaque panel identical to the one mounted on top of the valve compartment will be mounted on the unit.

UV - UV germicidal lamp kit

The germicidal UV lamp KIT is particularly suitable for hospitals or medical surgeries that require thorough cleaning and sterilization of the air, along with the filtering action usually conducted by the honeycomb filters installed on all the units.

The KIT features a support to install the light, which comes with a power-supply unit already wired for the electrical connection and can be applied on the whole ELFORoom² range.



OUTRAD - Vertical cased with continuous modulation DC motor, RS485 interface with built-in thermostat and ventilated radiant plate

OUTSRAD - Vertical cased with continuous modulation DC motor, RS485 interface, without built-in thermostat and with ventilated radiant plate

INRAD - Vertical uncased with continuous modulation DC motor, RS485 interface, without built-in thermostat and with ventilated radiant plate

The range of ELFORoom² terminals is extended with a new version that improves the comfort perceived in heating mode.

ELFORoom² with a radiant effect can quickly heat up in winter and cool down and dehumidify in summer by maintaining ideal thermal comfort levels.

Namely, during the heating stage it combines the convective and ventilating effect with the radiant effect of the front panel, thereby increasing comfort levels for people in the room.

Thanks to this exclusive operating principle, once the terminal has reached the comfort temperature, it maintains the ideal temperature without the support of the main fan and therefore operates in complete silence.

The fan is gradually switched off with a modulating control in relation to when the ambient temperature gets closer the desired one set on the control.

This exclusive solution is based on a simple and yet extremely efficient concept that prevents operating complications and poor reliability of integrated systems with special valves and radiators.

The size and design of the appliances are identical to the standard series and therefore utterly elegant and compact.

The operating principle is based on the activation, in winter mode, of microfans with very low energy consumption levels and completely silent that allow to send warm air coming from the heat exchanger towards the internal part of the appliance's front panel, thereby heating it up effectively.

The axial microfans, whose number varies according to the unit, start to operate only when the water temperature rises above 35°C.

This function can be activated individually, for instance during night-time operation, when the necessary output is lower and maximum silence is required. This way the comfort temperature is maintained thanks to an operation without significant movements of the air in complete silence.

In the summer mode, the air flow generated by the microfans is interrupted to prevent any dew from forming on the front of the terminal.

The option is compatible with all the electronics versions available, but not with the auxiliary coil option for 4-pipe systems.

In the INRAD vertical built-in configuration, the CSFIX formwork and the PCIX closing panel must be supplied, too.

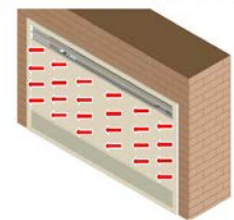
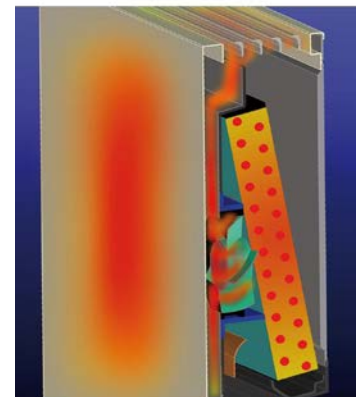
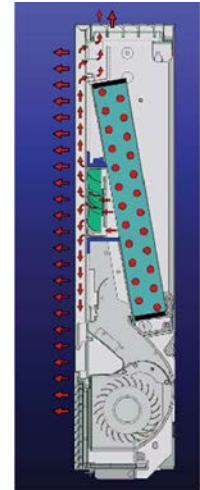

B4T - Auxiliary coil for systems with 4 pipes

Elfforom2 is available with auxiliary coil for 4-pipe system.

The room terminal can be ordered STD with connections to the left or set with connections to the right.

As for the 2-pipes units, if needed it is possible to rotate the coils directly in the yard.

To rotate from left to right provide with the kit KCMDX.



Caution: the unit so set (B4T) is larger than the units with 2-pipe system, see dimensional drawings.



This option is not compatible with the ventilated radiant plate

Performance in heating with 4-pipes coil

Size	Exchanger water inlet / outlet temperature (°C)					
	Ta (°C)	35/30	40/35	45/40	50/45	60/55
		kWt	kWt	kWt	kWt	kWt
003.0	10	0,43	0,54	0,74	0,91	1,08
	15	0,32	0,42	0,57	0,76	0,92
	18	0,25	0,36	0,46	0,66	0,83
	20	0,21	0,32	0,41	0,6	0,77
	22	0,17	0,27	0,38	0,53	0,71
	25	0,11	0,21	0,32	0,41	0,61
005.0	10	0,98	1,27	1,55	1,83	2,11
	15	0,7	1	1,28	1,56	1,83
	18	0,5	0,83	1,12	1,39	1,67
	20	0,37	0,72	1,01	1,29	1,56
	22	0,3	0,6	0,9	1,18	1,45
	25	0,2	0,37	0,73	1,02	1,29
011.0	10	1,21	1,66	2,07	2,46	2,85
	15	0,7	1,26	1,68	2,08	2,47
	18	0,56	0,99	1,45	1,85	2,24
	20	0,46	0,7	1,29	1,7	2,09
	22	0,37	0,61	1,13	1,55	1,94
	25	0,25	0,47	0,86	1,32	1,71
015.0	10	1,61	2,09	2,56	3,02	3,48
	15	1,11	1,64	2,11	2,57	3,03
	18	0,69	1,35	1,84	2,3	2,76
	20	0,58	1,16	1,66	2,12	2,58
	22	0,47	0,95	1,47	1,94	2,4
	25	0,31	0,58	1,19	1,67	2,13
017.0	10	2,13	2,74	3,32	3,87	4,98
	15	1,49	2,16	2,76	3,32	4,42
	18	0,84	1,80	2,41	2,99	4,08
	20	0,71	1,55	2,18	2,76	3,86
	22	0,59	1,28	1,95	2,54	3,64
	25	0,40	0,71	1,59	2,19	3,31

Ta = air intake temperature

kWt = Provided heating capacity (kW)

Water temperature differential = 5°C

Accessories separately supplied

KCMDX - Motor connection cables for units with connections on the right-hand side.

It is necessary to use the motor connection cables when the exchange coil is turned, on site, from the standard left-hand side to the right-hand side.

When the coil is turned, the electrical panel must be positioned on the opposite side. Therefore the KCMDX accessory is required to connect the motor whose position does not change.



KV3VBX - 3-way valve kit with electrothermal head and balancing for the 2-pipe version

The KIT consists of a valve with a 230/1/50 thermoelectric head and a reducing valve. The former allows to automatically exclude the terminal from the system via the on-board control, the reducing valve is used to balance the system's pressure drops.

- A. THERMO-ELECTRIC HEAD
- B. 3-WAY VALVE
- C. CONNECTION CABLES TO THE CONTROL BOARD
- D. FLEXIBLE PIPE
- E. REDUCING VALVE
- F. BRASS OUTLET FITTING

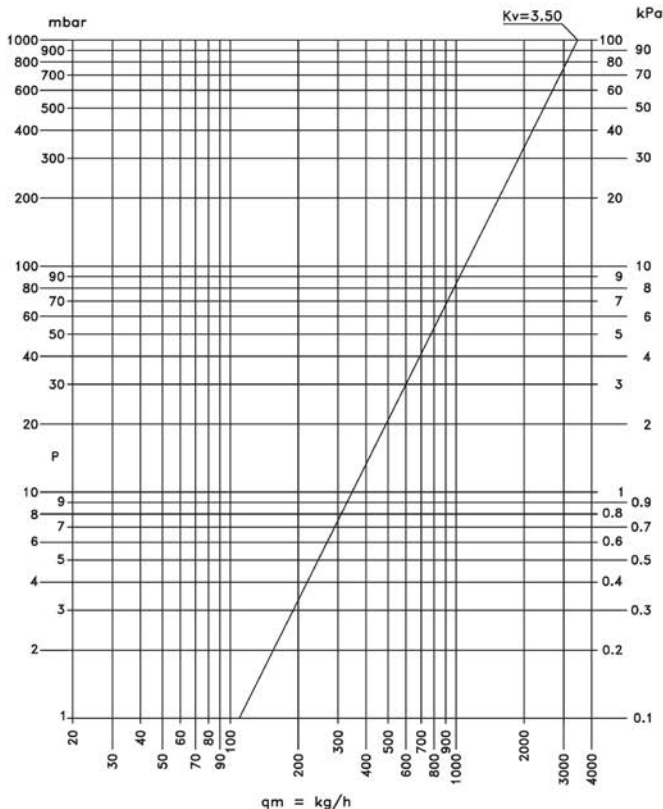

Diagram showing the shut-off valve's pressure drops with a fully open electrothermal head

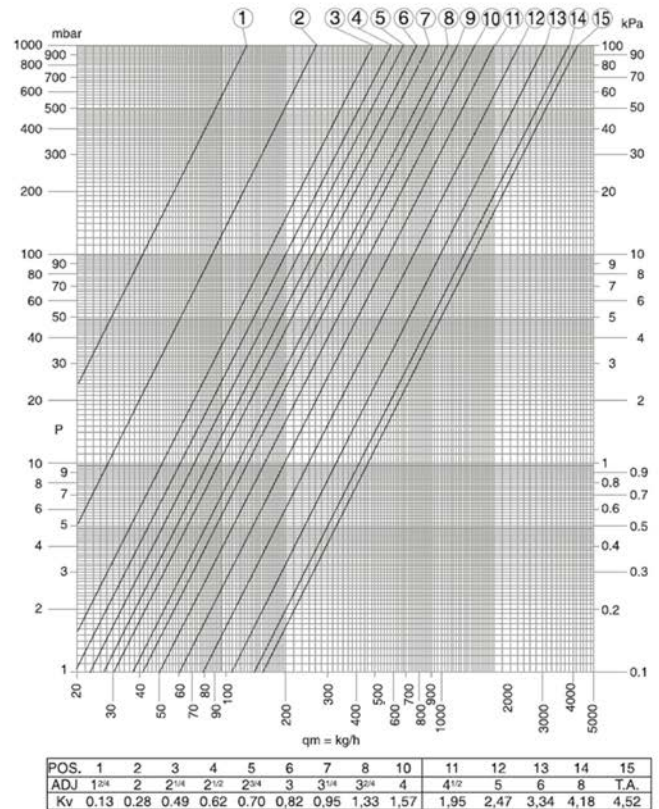
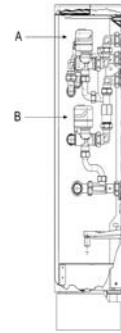

Diagram showing the reducing valve's pressure drops in relation to the adjustment (ADJ.) = No. of rotations

KV3B4X - 3-way valve kit with electrothermal head and balancing for a 4-pipe system

The 3-way valves allow to automatically exclude the system's terminal via the on-board control, the reducing valves are used to balance the system's pressure drops, while the bypass allows to ensure the systems are balanced even when the valves are closed.

- A. VALVE IN HEATING MODE
- B. VALVE IN COOLING MODE



KPDX - Feet Kit

The kit consists of two feet and 4 screw cylinder that is screwed into the underside of the terminal frame. This accessory allows you to place the cabinet on the ground in all wall installations and is available in white color RAL 9003.

- A. RAL 9003 RH FOOT EXT. COV. ASSEMBLY
- B. RAL 9003 LH FOOT EXT. COV. ASSEMBLY
- C. ROUND BAR FOR ALUMINIUM FOOT

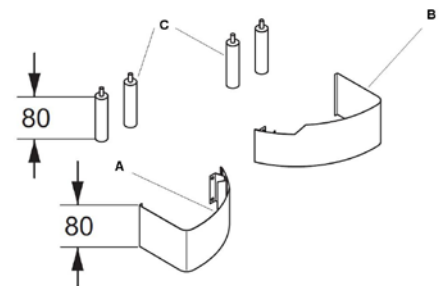

BACKVX - Rear painted panel for cased unit

The accessory painted rear panel is available in RAL 9003 white and is used to cover the rear of the unit when it is positioned in front of a shop window or in any case when the rear surface is exposed.

- A. REAR CLOSING PANEL
- B. JOINTS TO SECURE THE PANEL AND FIXING HOLES

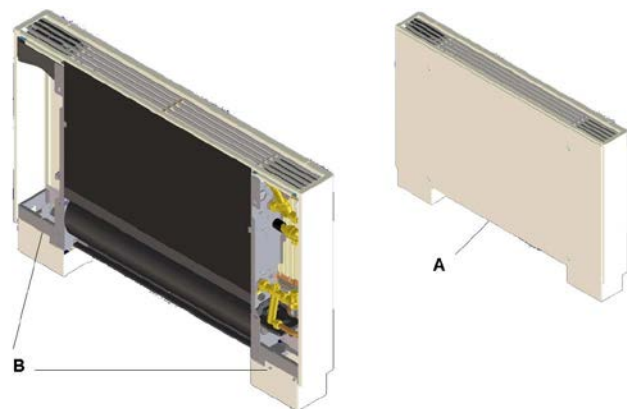

FXPPX - Floor fixing brackets kit

The KIT is used to secure the unit to the floor in the event of installations in which it is exposed in a shop window or in any case in all applications where it cannot be secured to a wall.

It is designed to be connected to the rear closing panel KIT, as it allows to conceal hydraulic pipes and the required electrical connections

- A. FLOOR FIXING SUPPORTS (RAL 9003)

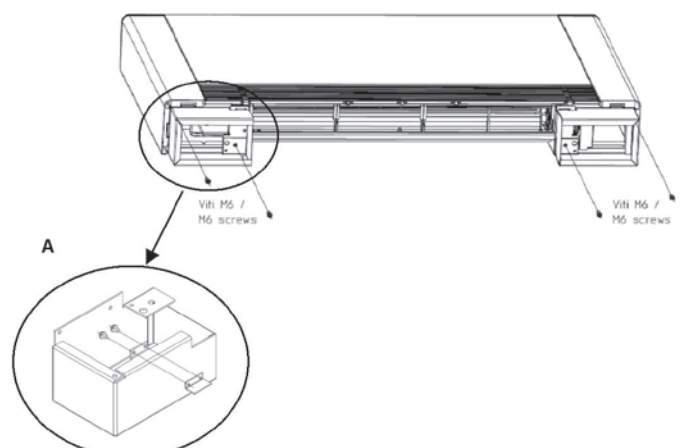

PMSTX - Upper telescopic supply plenum kit

The supply plenum KIT is used in cased versions to duct the air from the unit and to be connected with the supply grille Kit.

It is made up of a galvanized steel structure that is fixed to the supporting structure of the cabinet using screws and allows you to extend the plenum maximum up to 600 mm from the outlet of the cabinet because the tangential fan has an available pressure to overcome pressure drops of 600 mm for each duct.

Size		003.0	005.0	011.0	015.0	017.0
x	mm	305	505	705	905	1105
y	mm	335	535	735	935	1135

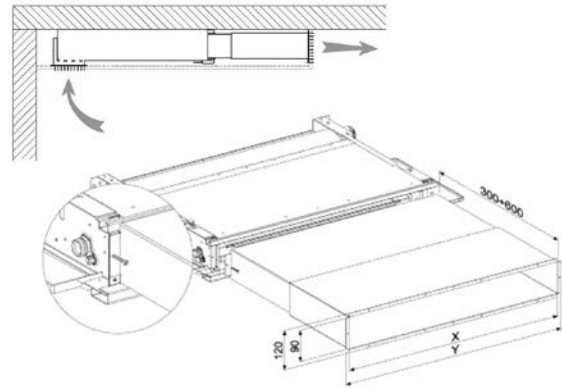

KASPX - Intake plenum kit

The intake KIT is used in built-in versions and allows to channel the air taken from the room.

It consists of an angular galvanised sheet metal profile that is secured to the unit with screws near the tangential fan and is already designed to be connected to the intake grids KIT.

The KIT allows to collect the air from the front of the unit by protruding by 15 mm in relation to the unit's outline.

Size		003.0	005.0	011.0	015.0	017.0
x	mm	305	505	705	905	1105
y	mm	335	535	735	935	1135

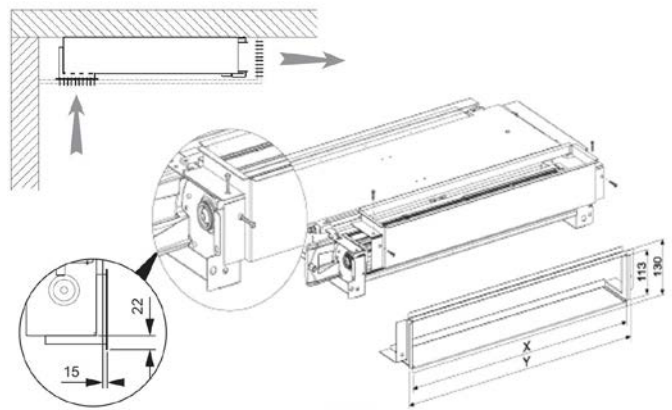

PR90MX - 90° supply plenum kit

The 90° supply plenum KIT is used in built-in versions to channel the air from the unit to the supply grille in false ceiling installations.

It is secured to the unit with screws on the designated holes on the profile of the unit's supply outlet and is already designed for the connection to the supply grilles KIT.

The accessory takes up 15 mm in relation to the outline of the unit.

Size		003.0	005.0	011.0	015.0	017.0
x	mm	305	505	705	905	1105
y	mm	335	535	735	935	1135

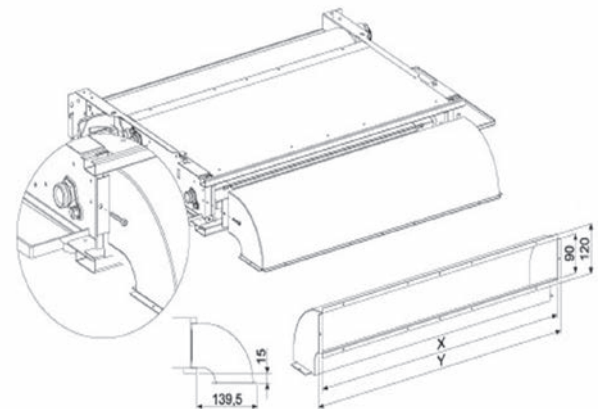

GMX - Supply grille

The supply grille KIT with double wing profile for wall installation and used in versions with a built-in unit.

The accessory is available in aluminium to ensure full integration for wall installation and adjustable fins to provide a better distribution of the air in the room. They are fitted with all the holes for the connection to the various telescopic supply plenum KITS (PMSTX) and 90°C plenum kits (PR90MX)

Size		003.0	005.0	011.0	015.0	017.0
Length (L)	mm	304	504	704	904	1104

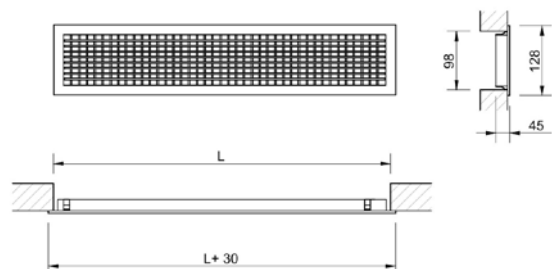

GRA1X - Air outflow grille

Intake grille KIT with wing profile for wall installation, used in versions with a built-in unit.

The accessory is available in aluminium to ensure full integration for wall installation and has all the holes for the connection to the intake plenum KIT (KASPX)

Size		003.0	005.0	011.0	015.0	017.0
Length (L)	mm	304	504	704	904	1104

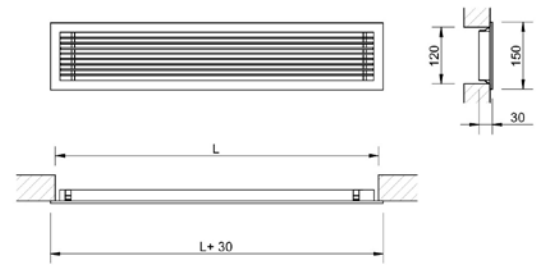

CSFIX - Formwork for built-in installation

The formwork KIT is used for built-in wall installations and allows to perform holes on the units on site.

The upper part of the formwork is insulated to prevent any condense from forming and the entire panel is already pre-cut and holes have been made to make it easier to position and pass the water pipes and power supply cables.

Size		003.0	005.0	011.0	015.0	017.0
Length (L)	mm	715	915	1115	1315	1515

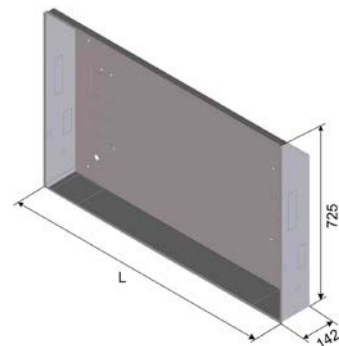

Drill a hole with minimum height of 730mm, depth of 142mm and L length (see tables) in the wall

Size		003.0	005.0	011.0	015.0	017.0
Length (L)	mm	740	940	1140	1340	1540

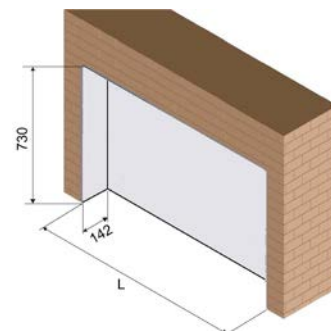

PCIX - Built-in closing panel

The built-in closing panel is used to complete the installation of the "Formwork kit" (CSFIX).

It has intake and supply grilles to distribute the ambient air and is made with RAL 9003 white painted galvanised sheet metal.

The air filters are located in the internal unit and can be inspected by opening the intake grille of the front covering panel.

Size		003.0	005.0	011.0	015.0	017.0
Height	mm	754	754	754	754	754
Length (L)	mm	772	972	1172	1372	1572
Depth	mm	29	29	29	29	29

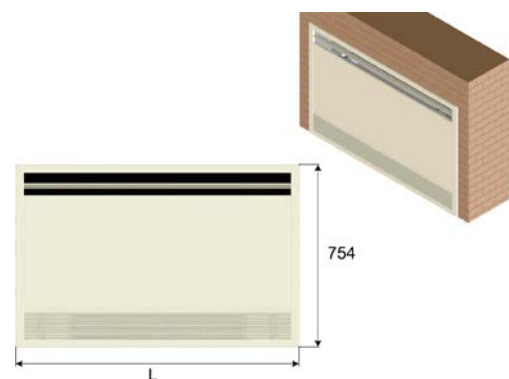

Note:

If you choose the RAD ventilated radiant plate option for INVOT built-in units, you must choose both the CSFIX formwork and the PCIX closing panel

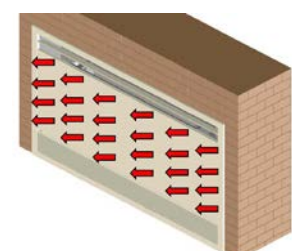

HID-T2X - HID-T2 temperature-only electronic room control, wall installation

The room thermostat allows to carry out the functions below:

- setting the desired temperature: temperature control range from 16°C to 28°C
- selection of the 3 speeds (MIN - MED - MAX) either manually or automatically
- ON/OFF
- manual/automatic Summer/Winter change
- select operation in economy mode
- set the unit's operating parameters
- report alarms with a specific code according to the kind of error

Dimensions: 127x86x27mm.

The thermostat is connected to the unit via a shielded twisted-pair cable at a maximum distance of 15m.



HID-T2, HID-T3 wall thermostat

HID-Ti2X - HID-TI2 temperature-only electronic room control, built-in installation

The room thermostat allows to carry out the functions below:

- setting the desired temperature: temperature control range from 16°C to 28°C
- manual or automatic speed selection (MIN-MAX)
- ON/OFF
- manual/automatic Summer/Winter change
- select operation in economy mode
- setting the unit's operating parameters
- report alarms with a specific code according to the kind of error

It is supplied with two interchangeable coloured masks, white and anthracite black.

The supplied fixing hangs allow mounting the thermostat to the plastic boxes (not supplied) normally used in the houses.

The thermostat is connected to the unit via a shielded twisted-pair cable at a maximum distance of 15m.

Dimensions: 65x45x54mm.



HID-T3X- HID-T3 electronic temperature and humidity room control, wall installation

The room thermostat allows to carry out the functions below:

- setting the desired temperature: temperature control range from 16°C to 28°C
- manual or automatic speed selection (MIN-MAX)
- ON/OFF
- manual/automatic Summer/Winter change
- select operation in economy mode
- set the unit's operating parameters
- humidity probe management
- humidity display
- report alarms with a specific code according to the kind of error

The thermostat is fitted with a humidity probe to detect the relative humidity in the room, which is useful for the connection to Elfosystem

Dimensions: 127x86x27mm.

The thermostat is connected to the unit through a shielded twisted pair cable at a maximum distance of 15m.



HID-T2, HID-T3 wall thermostat

HID-E1X - 3-speed selector + on/off selector for wall installation

Electromechanical room thermostat HID-E1 for wall installation

It allows:

- selection of the 3 speeds (MIN - MED - MAX)
- manual Summer / Winter change

The TM hot water min. temperature Clickson can be connected.

Dimensions: 184x82x27 mm

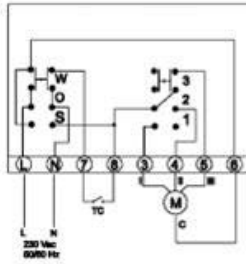

HID-E2X - Simplified ambient control E/I + 3V+ On/Off selector for wall installation

HID-E2 electro mechanical room thermostat for wall installation

It allows:

- setting the desired temperature (10-30°C)
- selection of the 3 speeds (MIN - MED - MAX)
- ON/OFF
- manual Summer / Winter change
- continuous or thermostat-based ventilation

It can be connected to the remote air probe

The TM hot water min. temperature Clickson can be connected.

Dimensions: 184x82x27 mm

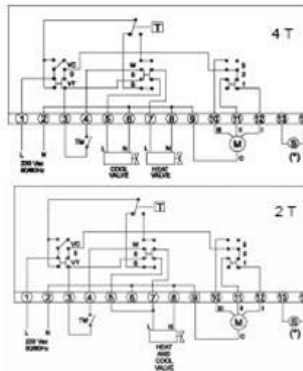

HID-E3X - Plurifunctional remote control for wall installation

HID-E3 electro mechanical room thermostat for wall installation

It allows:

- automatic fan speed adjustment (MIN - MED - MAX)
- silent operation (minimum fan speed)
- ON/OFF
- ambient temperature adjustment via the control knob: the knob's central position corresponds to the comfort condition (20°C in heating mode, 24°C in cooling mode). The temperature can be changed by +/- 5°C in relation to the comfort condition by turning the knob
- automatic selection of the Summer/Winter season: the heating or cooling mode is selected automatically by detecting the water temperature supplied to the fan-coil (water temperature below 17°C=operation in cooling mode, water temperature above 21°C=operation in heating mode)
- Hot Start function: in heating mode the fan does not start until the thermal coil is not hot enough
- destratification cycle
- dirty filter warning
- minimum water temperature probe (supplied separately)

Dimensions: 184x82x27 mm

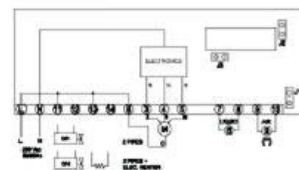

Dimensional drawings

Cased version

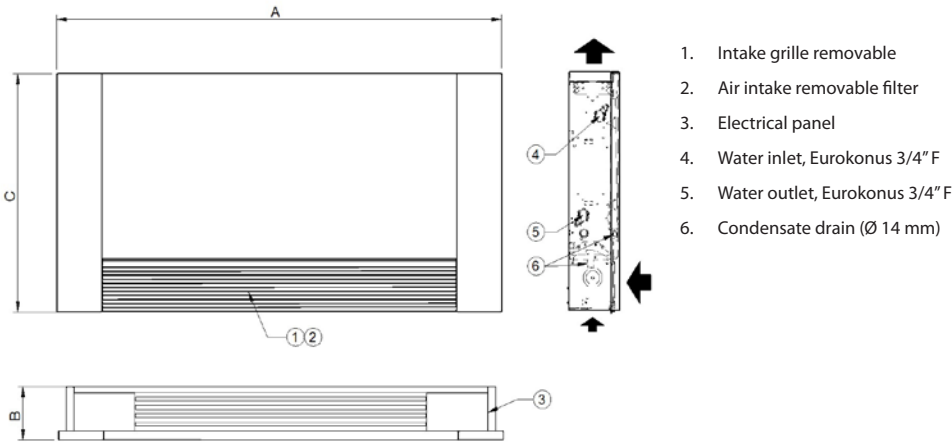

- 1. Intake grille removable
- 2. Air intake removable filter
- 3. Electrical panel
- 4. Water inlet, Eurokonus 3/4" F
- 5. Water outlet, Eurokonus 3/4" F
- 6. Condensate drain (Ø 14 mm)

ELFORoom ² - 2 uncased pipes		003.0	005.0	011.0	015.0	017.0
A	mm	737	937	1137	1337	1537
B	mm	130	130	130	130	130
C	mm	579	579	579	579	579
Operating weight	kg	17	20	23	26	29
Shipping weight	kg	18	21	24	27	30

Uncased version

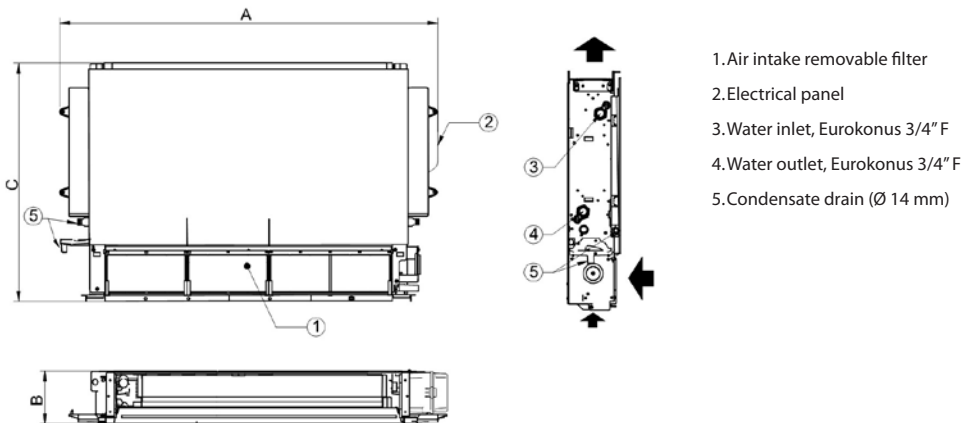

- 1. Air intake removable filter
- 2. Electrical panel
- 3. Water inlet, Eurokonus 3/4" F
- 4. Water outlet, Eurokonus 3/4" F
- 5. Condensate drain (Ø 14 mm)

ELFORoom ² - 2 cased pipes		003.0	005.0	011.0	015.0	017.0
A	mm	527	727	927	1227	1327
B	mm	130	130	130	130	130
C	mm	586	586	586	586	586
Operating weight	kg	9	12	15	18	21
Shipping weight	kg	10	13	16	19	22

4 pipes version dimensional drawings

Cased version

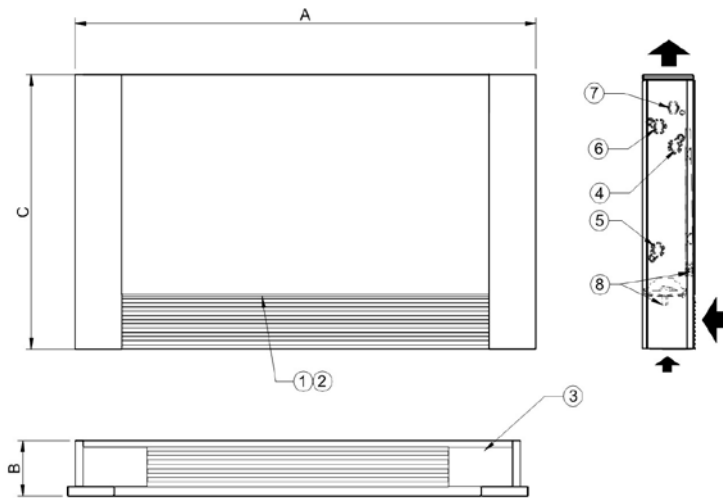

- 1. Intake grille removable
- 2. Air intake removable filter
- 3. Electrical panel
- 4. Water inlet, Eurokonus 3/4" F
- 5. Water outlet, Eurokonus 3/4" F
- 6. Additional coil water inlet 3/4" F (4 pipe-installation)
- 7. Additional coil water outlet 3/4" F (4 pipe- installation)
- 8. Condensate drain (Ø 14 mm)

ELFORoom ² -4 uncased pipes		003.0	005.0	011.0	015.0	017.0
A	mm	737	937	1137	1337	1537
B	mm	130	130	130	130	130
C	mm	639	639	639	639	639
Operating weight	kg	18	21	25	28	32
Shipping weight	kg	19	22	26	29	33

Uncased version

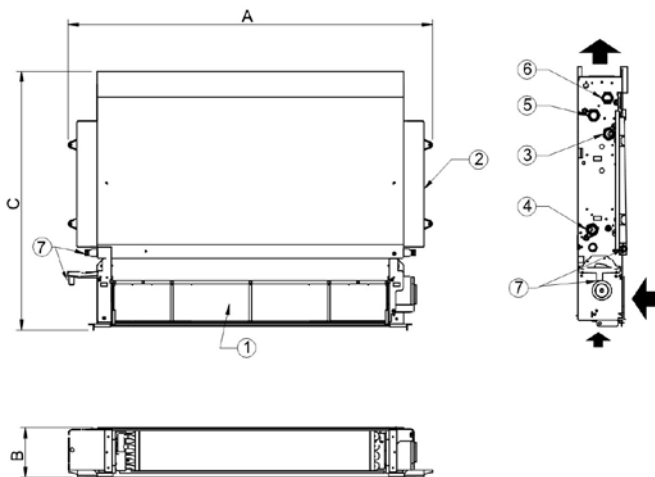

- 1. Air intake removable filter
- 2. Electrical panel
- 3. Water inlet, Eurokonus 3/4" F
- 4. Water outlet, Eurokonus 3/4" F
- 5. Additional coil water inlet 3/4" F (4 pipe-installation)
- 6. Additional coil water outlet 3/4" F (4 pipe- installation)
- 7. Condensate drain (Ø 14 mm)

ELFORoom ² -4 cased pipes		003.0	005.0	011.0	015.0	017.0
A	mm	527	727	927	1127	1327
B	mm	130	130	130	130	130
C	mm	650	650	650	650	650
Operating weight	kg	10	13	17	20	24
Shipping weight	kg	11	14	18	21	25

Pattern for installation

ELFORoom²- 2 pipes

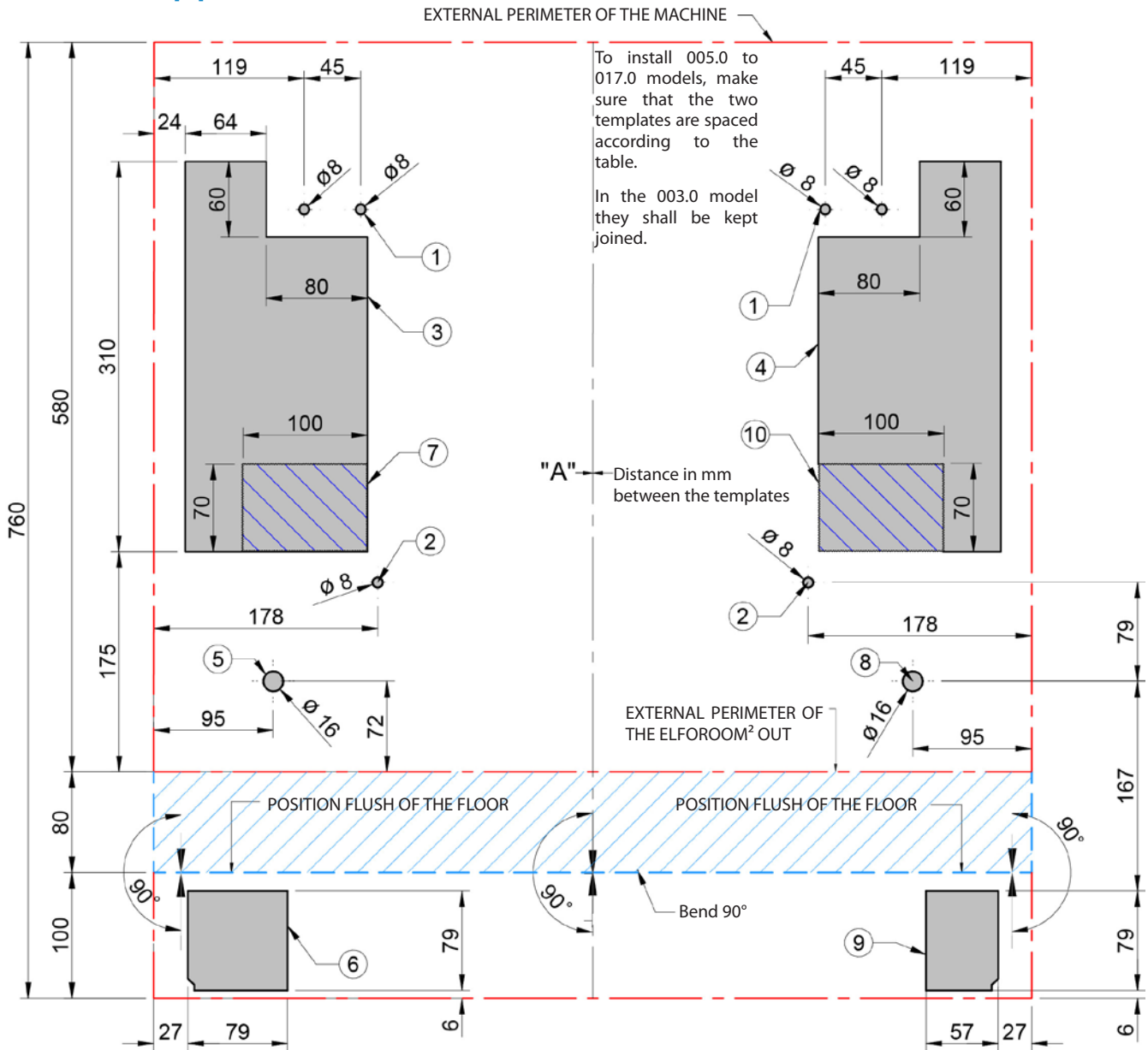

Key	
1	holes for dowels
2	hole for dowel horizontal position
3	hydraulic wall connections zone with flexible pipers (standard on left)
4	hydraulic wall connections zone with flexible pipers (on right)
5	condensate drainfor installation on left
6	area for pipe passage from the floor (on the left)
7	electrical box for hydraulic connectors (on the right)
8	condensate drainfor installation on right
9	area for pipe passage from the floor (on the right)
10	electrical box for hydraulic connectors (on the right)

Unit	SIZE	A (mm)	
ElfoRoom ²	003.0	-	To install 005.0 to 017.0 models, make sure that the two templates are spaced according to the table. In the 003.0 model they shall be kept joined.
ElfoRoom ²	005.0	200	
ElfoRoom ²	011.0	400	
ElfoRoom ²	015.0	600	
ElfoRoom ²	017.0	800	

ELFORoom²- 4 pipes

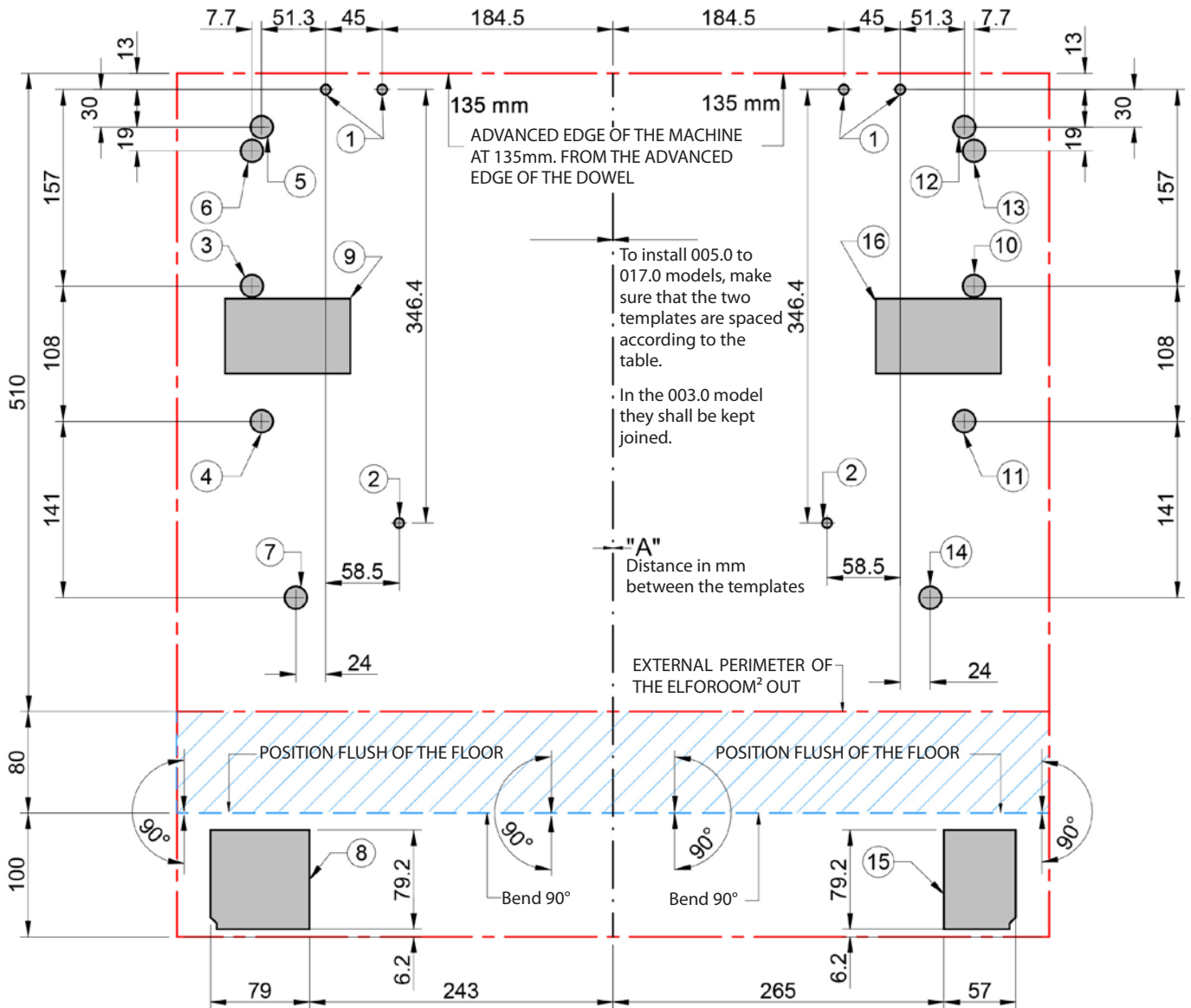

Key			
1	holes for dowels Ø 8 mm	9	electrical box for hydraulic connectors (on the right)
2	hole for dowel horizontal position Ø8mm	10	inlet position for installation on right with 3-way valve(with 90° elbow)
3	inlet position for installation on left with 3-way valve(with 90° elbow-standard coil)	11	outlet position for installation on right with 3-way valve(with 90° elbow)
4	outlet position for installation on left with 3-way valve(with 90° elbow-standard coil)	12	inlet position for installation on right with 3-way valve(with 90° elbow-additional coil)
5	inlet position for installation on left with 3-way valve(with 90° elbow-additional coil)	13	outlet position for installation on right with 3-way valve(with 90° elbow-additional coil)
6	outlet position for installation on left with 3-way valve(with 90° elbow-additional coil)	14	condensate drainfor installation on right
7	condensate drainfor installation on left	15	area for pipe passage from the floor
8	area for pipe passage from the floor	16	electrical box for hydraulic connectors (on the left)

Unit	SIZE	A (mm)
ElfoRoom ²	003.0	-
ElfoRoom ²	005.0	200
ElfoRoom ²	011.0	400
ElfoRoom ²	015.0	600
ElfoRoom ²	017.0	800

To install 005.0 to 017.0 models, make sure that the two templates are spaced according to the table.
In the 003.0 model they shall be kept joined.

Clearance access recommended

Uncased version

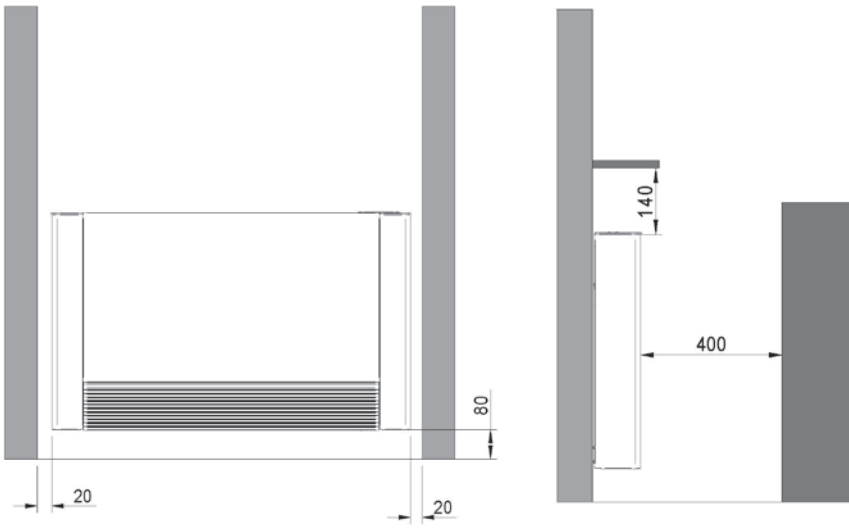

Cased version

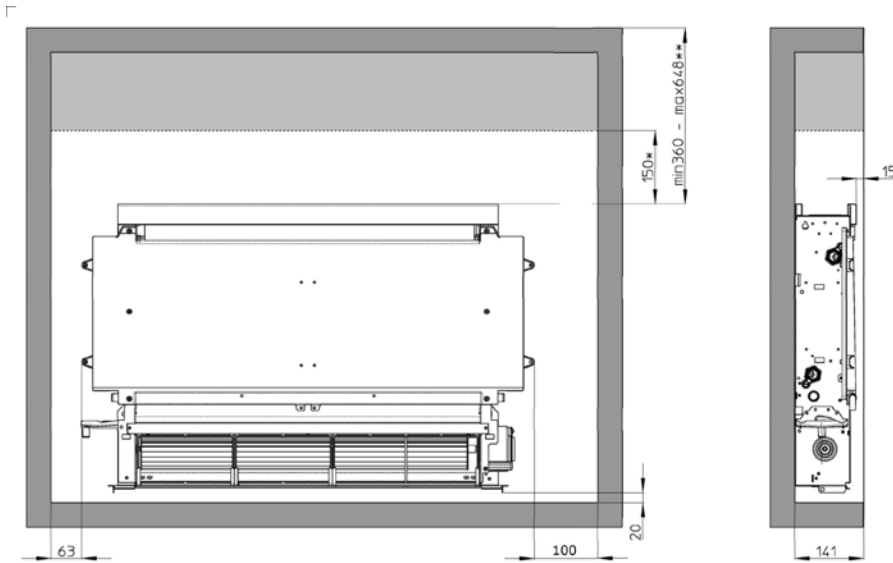

MINIMUM DISTANCES TO FOLLOW FOR CORRECT OPERATION AND ROUTINE MAINTENANCE.

*= DIMENSIONS TO FOLLOW TO ASSEMBLE THE 90° INSULATED SUPPLY PLENUM KIT, CODE PR90MX

*= DIMENSIONS TO FOLLOW TO ASSEMBLE THE TELESCOPIC UPPER SUPPLY PLENUM KIT, CODE PMSTX

Description per specification of supply

Specification description of Elforoom² vertical autonomous uncased

Supply and installation of fan-coil with a autonomous built in control system. It consists of a high efficiency copper and aluminium exchange coil with a finned heating element fitted with a spindle; supporting load-bearing structure made with electrogalvanised sheet steel; a PVC shock-proof condensate tray and rear panel made with sound-absorbing material. Tangential fan unit made with synthetic material and fitted with staggered fins (top silence levels) with continuous modulating DC brushless motor mounted on EPDM antivibration supports; drop-down painted aluminium return grille made with removable filter made with tight-knit synthetic mesh; shooting grid opens door in painted aluminium with removable air filter polypropylene mesh with weighted efficiency to 48% gravimetric method, complete casing in steel sheet painted with epoxy RAL 9003; upper grille with adjustable fins and set-up control panel of with ambient thermostat (summer/winter) and LED to report the set-up functions. 3/4" LH and RH Eurokonus hydraulic connections.

Specification description of Elforoom² vertical-horizontal uncased for remote installation

Supply and installation of an uncased fan-coil with a control system for the connection to the wall thermostat. It consists of a high efficiency copper and aluminium exchange coil with a finned heating element fitted with a spindle; supporting load-bearing structure made with electrogalvanised sheet steel; a PVC shock-proof condensate tray and rear panel made with sound-absorbing material. Tangential fan unit made with synthetic material and fitted with staggered fins (top silence levels) with continuous modulating DC brushless motor mounted on EPDM antivibration supports; drop-down painted aluminium return grille made with removable filter made with tight-knit synthetic mesh; full casing made with oven-painted sheet steel with RAL 9003 epoxy powder; upper grille with adjustable fins and control panel with ON/OFF key and LED to report dirty filters and if there is an alarm. 3/4" LH and RH Eurokonus hydraulic connections. Supply and installation of an uncased fan-coil with a control system for the connection to the wall thermostat. It consists of a high efficiency copper and aluminium exchange coil with a finned heating element fitted with a spindle; supporting load-bearing structure made with electrogalvanised sheet steel; a PVC shock-proof condensate tray and rear panel made with sound-absorbing material. Tangential fan unit made with synthetic material and fitted with staggered fins (top silence levels) with continuous modulating DC brushless motor mounted on EPDM antivibration supports; drop-down painted aluminium return grille made with removable filter made with tight-knit synthetic mesh; full casing made with oven-painted sheet steel with RAL 9003 epoxy powder; upper grille with adjustable fins and control panel with ON/OFF key and LED to report dirty filters and if there is an alarm. 3/4" LH and RH Eurokonus hydraulic connections.

Specification description of Elforoom² vertical-horizontal cased for remote installation

Supply and installation of a built-in fan-coil with a control system for the connection to the wall thermostat. It consists of a high efficiency copper and aluminium exchange coil with a finned heating element fitted with a spindle; supporting load-bearing structure made with electrogalvanised sheet steel; a PVC shock-proof condensate tray and rear panel made with sound-absorbing material. Tangential fan unit made with synthetic material and fitted with staggered fins (maximum silence) with continuous modulating DC brushless motor mounted on EPDM antivibration supports and removable filter made with tight-knit synthetic mesh. 3/4" LH and RH Eurokonus hydraulic connections. Supply and installation of a built-in fan-coil with a control system for the connection to the wall thermostat. It consists of a high efficiency copper and aluminium exchange coil with a finned heating element fitted with a spindle; supporting load-bearing structure made with electrogalvanised sheet steel; a PVC shock-proof condensate tray and rear panel made with sound-absorbing material. Tangential fan unit made with synthetic material and fitted with staggered fins (maximum silence) with continuous modulating DC brushless motor mounted on EPDM antivibration supports and removable filter made with tight-knit synthetic mesh. 3/4" LH and RH Eurokonus hydraulic connections.

Specification description of Elforoom² vertical autonomous uncased with ventilated radiant plate

Supply and installation of fan-coil with a autonomous built in control system. It consists of a high efficiency copper and aluminium exchange coil with a finned heating element fitted with a spindle; supporting load-bearing structure made with electrogalvanised sheet steel; a PVC shock-proof condensate tray and rear panel made with sound-absorbing material. Tangential fan unit made with synthetic material and fitted with staggered fins (top silence levels) with continuous modulating DC brushless motor mounted on EPDM antivibration supports; drop-down painted aluminium return grille made with removable filter made with tight-knit synthetic mesh; shooting grid opens door in painted aluminium with removable air filter polypropylene mesh with weighted efficiency to 48% gravimetric method, complete casing in steel sheet painted with epoxy RAL 9003; upper grille with adjustable fins and set-up control panel of with ambient thermostat (summer/winter) and LED to report the set-up functions. Ventilated radiant plate made up low-consumption micro-fans that send hot air, coming from the heat exchanger, towards the inside of the front panel. 3/4" LH and RH Eurokonus hydraulic connections.

Specification description of Elforoom² vertical cased for remote installation with ventilated radiant plate

Supply and installation of a built-in fan-coil with a control system for the connection to the wall thermostat. It consists of a high efficiency copper and aluminium exchange coil with a finned heating element fitted with a spindle; supporting load-bearing structure made with electrogalvanised sheet steel; a PVC shock-proof condensate tray and rear panel made with sound-absorbing material. Tangential fan unit made with synthetic material and fitted with staggered fins (maximum silence) with continuous modulating DC brushless motor mounted on EPDM antivibration supports and removable filter made with tight-knit synthetic mesh. Ventilated radiant plate made with low-consumption microfans that send hot air coming from the heat exchanger towards the inside of the built-in structure's closing panel. This configuration must be combined with the formwork for in-built installation and the in-built closing panel. 3/4" LH and RH Eurokonus hydraulic connections.

page intentionally left blank

page intentionally left blank

**CLIVET SPA**

Via Camp Lonc 25, Z.I. Villapaiera - 32032 Feltre (BL) - Italy
Tel. + 39 0439 3131 - Fax + 39 0439 313300 - info@clivet.it

CLIVET UK LTD (Sales)

4 Kingdom Close, Segensworth East - Fareham, Hampshire - PO15 5TJ - United Kingdom
Tel. + 44 (0) 1489 572238 - Fax + 44 (0) 1489 573033 - info@clivet-uk.co.uk

CLIVET AIRCON LTD (Service and Maintenance Division)

Units F5&F6 Railway Triangle Ind Est, Walton Road - Portsmouth, Hampshire - PO6 1TG - United Kingdom
Tel. +44 (0) 2392 381235 - Fax. +44 (0) 2392 381243 - info@clivetaircon.co.uk

CLIVET ESPAÑA COMERCIAL S.L. (Sales)

Calle Gurb, 17 1º 1ª - 08500 Vic, Barcelona - España
Tel: +34 93 8606248 - Fax +34 93 8855392 - info@clivetcomercial.com

CLIVET ESPAÑA S.A.U. (Service and Maintenance Division)

Calle Real de Burgos Nº 12 - 28860 Paracuellos del Jarama, Madrid - España
Tel. +34 91 6658280 - Fax +34 91 6657806 - info@clivet.es

CLIVET GmbH

Hummelsbütteler Steindamm 84, 22851 Norderstedt - Germany
Tel. + 49 (0) 40 32 59 57-0 - Fax + 49 (0) 40 32 59 57-194 - info.de@clivet.com

CLIVET RUSSIA

Elektrozavodskaya st. 24, office 509 - 107023, Moscow, Russia
Tel. + 74956462009 - Fax + 74956462009 - info.ru@clivet.com

CLIVET MIDEAST FZCO

Dubai Silicon Oasis (DSO), High Bay Complex, Ind Unit No. 3, PO BOX 28178, Dubai, UAE
Tel. + 9714 3208499 - Fax + 9714 3208216 - info@clivet.ae

CLIVET AIRCONDITIONING SYSTEMS PRIVATE LIMITED

4BA, Gundecha Onclave - Kherani Road, Saki Naka, Andheri (East) - Mumbai 400 072 - India
Tel. +91 22 6193 7000 - Fax +91 22 6193 7001 - info.in@clivet.com