

# ELFOSpace

New generation cased and uncased water terminal unit for vertical and horizontal indoor installation in the commercial sector

## ELFOSpace 003.0 - 051.0



- ▶ **12 SIZES**  
with an endless range of accessories to meet every requirement of system applications
- ▶ **HIGH ENERGY EFFICIENCY**  
in the configuration with fan deck with DC motor
- ▶ **VERY LOW SOUND LEVELS**  
thanks to the double air inlet centrifugal fans directly coupled to the electric motor'
- ▶ **SIMPLE AND INTUITIVE CONTROLS**  
satisfying the most varied of requirements
- ▶ **AVAILABLE FOR 2 AND 4 PIPE SYSTEM**



Nominal cooling capacity from 1,50 to 10,7 kW  
Nominal heating capacity from 3,74 to 23,2 kW



## Terminal unit Clivet

The hydronic terminal units are very diffused for their versatility and reliability. The Clivet range includes many versions that simplify the application in different types of installation and building.

	Commercial			
	ELFOSpace	ELFODuct MP ELFODuct HP	ELFOSpace BOX3	ELFOSpace WALL3
Capacities (A27/W7)	1,5 ÷ 11 kW	6 ÷ 25 kW	3 ÷ 11 kW	2 ÷ 4,5 kW
 Vertical cased				
 Horizontal cased				
 Vertical uncased				
 Horizontal uncased				
 2 pipes	✓	✓	✓	✓
 4 pipes	✓	✓	✓	
 DC Motor	✓	✓	✓	✓
 High head		✓		
 RS485 Connection	✓	✓	✓	✓

# Standard unit technical specifications

## Structure

Built-in thick sheet, galvanized and pre-coated with a polyvinyl chloride film, resistant to rust, corrosion, chemicals, thinners, aliphatics, alcohols. Coating film thickness about 10 times higher than the one of a standard epoxy-powder painting (much more resistant to abrasion). Thermal and sound inner insulation (class M1). Fastening holes for wall or ceiling mounting.

## Cabinet

For in-view units, the cabinet is white (similar to RAL9010), with a refined, modern and elegant design, with rounded harmonious forms that fit in well with any setting. Air supply grille in grey ABS similar to (RAL 7035), with fixed fins, adjustable to two positions (the flow of air can be inverted by turning the grille 180°), equipped with opening side doors to access the internal control panel (the control panel is an accessory)

## Internal exchanger

Highly efficient heat exchange coil (turbulence fins with high Reynolds number) in copper pipe and aluminum fins locked by mechanical expansion. Coil fittings with anti-twisting system, manual air bleeding valves, manual water draining valves. Standard connections on the left side (defined by standing in front of the unit, with the air blowing on your face) and on request connections on the right side, anyway the unit can be easily reversed even on construction site.

N°1 coil (3 rows) for 2 pipe system and n°2 coils (3+1 rows) for 4 pipe system.

The coils are tested for a 30 bar pressure and are suitable for operating up to a 15 bar pressure with installed valve kit.

## Fan

Ventilating unit composed of 1, 2 or 3 centrifugal fans with double intake and plastic impellers (with forward curved blades) directly coupled with the motor. Assembly on elastic supports and shock-absorbers. Statically and dynamically balanced fan. Impellers with large diameter and low rpm. Centrifugal fan, positioned at the air side exchanger.

Motor equipped with thermal relay (clickson), working condenser always on, IP42, class B, wires protected by double insulation.

- From size 003.0 to 031.0 = Provided with single-speed motor + autotransformer with 6 outputs in order to have 6 equal-distance speed. Factory standard pre-connected speed are n° 2-3-5 (with 1=max and 6=min).
- Sizes 041.0 and 051.0 = Potentiate units with motor with 5 or 6 speed obtained directly on the motor. Factory pre-wired electrical standard 2-3-4 intermediate speeds (with 1=max and 5=min).

Fan section easy to remove (fixed by just 4 screws).

## Filtration

Easily removable air filter, composed of a metal frame incorporating the filtering plate. It can be regenerated by water-washing, blowing, vacuuming. In resin-coated and interwoven polyester acrylic cloth, with high efficiency. Suitable for dusts and pollens (filtering degree G3, class M1).

## Drain pan

Drain pan provided with condensation drain Ø20 and thermal insulation (class M1).

Only for vertical versions: condensation drain funnel with Ø20mm pipe, realized in plastic material (standard supplied in the same side of the water connections) terminating externally to the unit side, for an easy and fast connection to the condensation drain pipe.

## Electrical panel

In all series the electrical panel is composed of a simple terminal board for connection to the motor type "Mamut" IP20 (min. 7 poles: 1 Ground + 3 speed + 1 Common + 2 for Bridge) installed outside the unit (standard on opposite to water connection side).

# ELFOSpace INV configuration code - Vertical uncased unit

	(1)	(2)	(3)	(4)	(5)	(6)	(7)	(8)	(9)	(10)	(11)	(12)	(13)	(14)	(15)
ELFOSpace	INV	003.0	230M	CC2	SX	VENS	MS	R3	TR	-	-	-	-	-	-
		003.0	230M	CC2 (Std)	SX (Std)	VENS (Std)	MS (Std)	R3 (Std)	TR (Std)	- (Std)	- (Std)	- (Std)	- (Std)	- (Std)	- (Std)
		005.0		CC4	DX	VEC	MR	RF	TRM	CTSP1	CPVM	RE	CDP	2V2	3V2
		007.0							TRP					2V4	3V4
		009.0							TRMP					10V2	10V4
		011.0							HIDF1						
		015.0							HIDF2						
		017.0							HIDF4						
		021.0							HIDF5						
		025.0							HIDF6						
		031.0							HIDF7						
		041.0							HIDF8						
		051.0													

## (1) Voltage

- 230M-Supply voltage 230/1/50

## (2) Coil configuration

- CC2 - Coil configuration for 2 pipe system (standard)
- CC4 - Coil configuration for 4 pipe system

## (3) Water fittings

- SX - Water fittings to the left (standard)
- DX - Water fittings to the right

## (4) Fans

- VENS - Standard AC fans (standard)
- VEC - High efficiency EC fan (available with options: TR, TRM, TRP, TRMP, CTSP1 + CPVM)

## (5) Air supply

- MS - Standard outlet (standard)
- MR - 90° air outlet

## (6) Air inlet

- R3 - Floor air inlet (standard)
- RF - Front air inlet

## (7) Controls keyboard

- TR - Terminal block for motor connection (standard)
- TRM - Terminal block with minimum water temperature clickson
- TRP - Terminal block with closing cover IP40.
- TRMP - Terminal block with closing cover IP40 and minimum water temperature clickson
- HIDF1 Control on the unit: off + 3 speed switch
- HIDF2 - Built-in control: BULB thermostat (3 speed + off + E/I + Temp.selection)
- HIDF4 - Control on the unit: BULB thermostat (3 speed + off + E/I + Temp.select.) + min. temperature thermostat
- HIDF5 - Control on the unit: BULB thermostat + on/off heaters
- HIDF6 - Control mounted on unit's side: multi-function electronic room thermostat
- HIDF7 - Built-in control: electronic thermostat with display
- HIDF8 - Control built-in installed: electronic thermostat with display for 3-speed or 0-10V fan and on/off or 0-10V valve

## (8) Electronic version

- (-) - Not required (standard)
- CTSP1 - CLIVET TALK TERMINAL SPACE electronics with RS485 Modbus serial port

## (9) Additional cards

- (-) - Not required (standard)
- CPVM - Control additional card of 0-10V valve and EC fan (available only with options: CTSP1)

## (10) Electric heaters

- (-) - Not required (standard)
- RE - Electric heaters

## (11) Condensate drain pump

- (-) - Not required (standard)
- CDP - Condensate pump

## (12) 2-way valves

- (-) - Not required (standard)
- 2V2 - ON/OFF 2-way valve kit for 2 pipe system
- 2V4 - ON/OFF 2-way valve kit for 4 pipe system

## (13) 3-way valves

- (-) - Not required (standard)
- 3V2 - Three-way valve kit for 2 pipe type "on/off" system
- 3V4 - Three-way valve kit for 4 pipe type "on/off" system
- 10V2 - 0-10V 3-way valve kit for 2 pipe system
- 10V4 - 0-10V 3 way valve kit for 4 pipe system

## (14) Water balancing kit

- (-) - Not required (standard)
- KBI2 - 2 tube water balancing kit = ball valve+water balancing kit
- KBI4 - 4 tube water balancing kit = 2 ball valves+2 water balancing kit

## (15) Auxiliary condensate collection tray

- (-) - Not required (standard)
- BRV - Auxiliary condensate collection pan (vertical installation)

## ELFOSpace INV versions - Vertical uncased unit

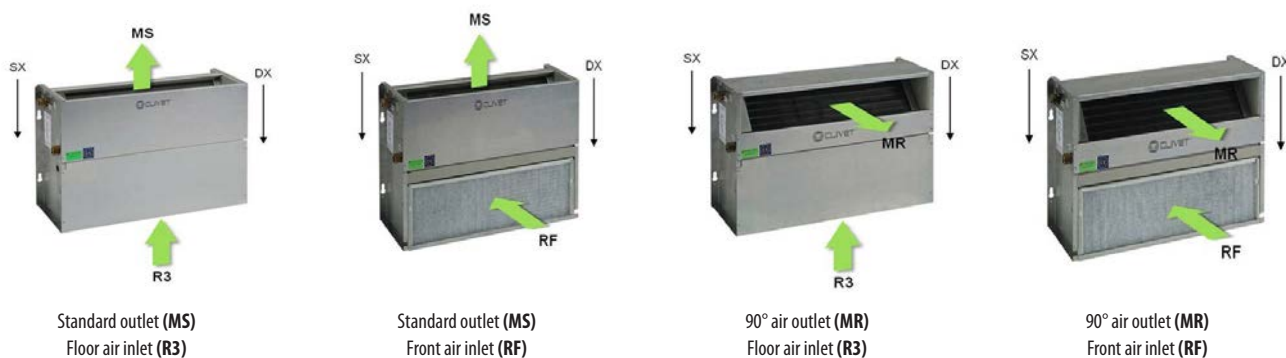

All ELFOSpace INV units are ductable (ESP up to 75Pa). For the rear intake with oblique downward filter extraction version (RPF0), to be able to duct the unit it's necessary to remove the filter and place it "upstream" of the unit, inside the duct.



References for position of fittings: right and left defined by standing in front of the unit (with the air blowing on your face).

# ELFOSpace INH configuration code - Horizontal uncased unit

ELFOSpace	INH	003.0	(1) 230M	(2) CC2	(3) SX	(4) VENS	(5) MS	(6) RPFO	(7) TR	(8) -	(9) -	(10) -	(11) -	(12) -	(13) -	(14) -	(15) -
		003.0 005.0 007.0 009.0 011.0 015.0 017.0 021.0 025.0 031.0 041.0 051.0	230M	CC2 (Std) CC4	SX (Std) DX	VENS (Std) VEC	MS (Std)	RPFO (Std) RPFB RPFA R3	TR (Std) TRM TRP TRMP	- (Std) CTSP1	- (Std) CPVM	- (Std) RE	- (Std) CDP	- (Std) 2V2 2V4	- (Std) 3V2 3V4 10V2 10V4	- (Std) KB12 KB14	- (Std) BROP

**(1) Voltage**

- 230M-Supply voltage 230/1/50

**(2) Coil configuration**

- CC2 - Coil configuration for 2 pipe system (standard)
- CC4 - Coil configuration for 4 pipe system

**(3) Water fittings**

- SX - Water fittings to the left (standard)
- DX - Water fittings to the right

**(4) Fans**

- VENS - Standard AC fans (standard)
- VEC - High efficiency EC fan (available with options: TR, TRM, TRP, TRMP, CTSP1 + CPVM)

**(5) Air supply**

- MS - Standard outlet (standard)

**(6) Air inlet**

- RPFO - Rear intake with oblique downward filter extraction (standard)
- RPFB - Rear intake with vertical downward filter extraction
- RPFA - Rear intake with vertical upward filter extraction
- R3 - Floor air inlet

**(7) Controls keyboard**

- TR - Terminal block for motor connection (standard)
- TRM - Terminal block with minimum water temperature clickson
- TRP - Terminal block with closing cover IP40.
- TRMP - Terminal block with closing cover IP40 and minimum water temperature clickson

**(8) Electronic version**

- (-) - Not required (standard)
- CTSP1 - CLIVET TALK TERMINAL SPACE electronics with RS485 Modbus serial port

**(9) Additional cards**

- (-) - Not required (standard)
- CPVM - Control additional card of 0-10V valve and EC fan (available only with options: CTSP1)

**(10) Electric heaters**

- (-) - Not required (standard)
- RE - Electric heaters

**(11) Condensate drain pump**

- (-) - Not required (standard)
- CDP - Condensate drain pump

**(12) 2-way valves**

- (-) - Not required (standard)
- 2V2 - ON/OFF 2-way valve kit for 2 pipe system
- 2V4 - ON/OFF 2 way valve kit for 4 pipe system

**(13) 3-way valves**

- (-) - Not required (standard)
- 3V2 - Three-way valve kit for 2 pipe type "on/off" system
- 3V4 - Three-way valve kit for 4 pipe type "on/off" system
- 10V2 - 0-10V 3-way valve kit for 2 pipe system
- 10V4 - 0-10V 3 way valve kit for 4 pipe system

**(14) Water balancing kit**

- (-) - Not required (standard)
- KB12 - 2 pipe water balancing kit = ball valve+water balancing kit
- KB14 - 4 pipe water balancing kit = 2 ball valves+2 water balancing kit

**(15) Auxiliary condensate collection tray**

- (-) - Not required (standard)
- BROP - Auxiliary drain pan (horizontal installation)

## ELFOSpace INH versions - Horizontal uncased unit

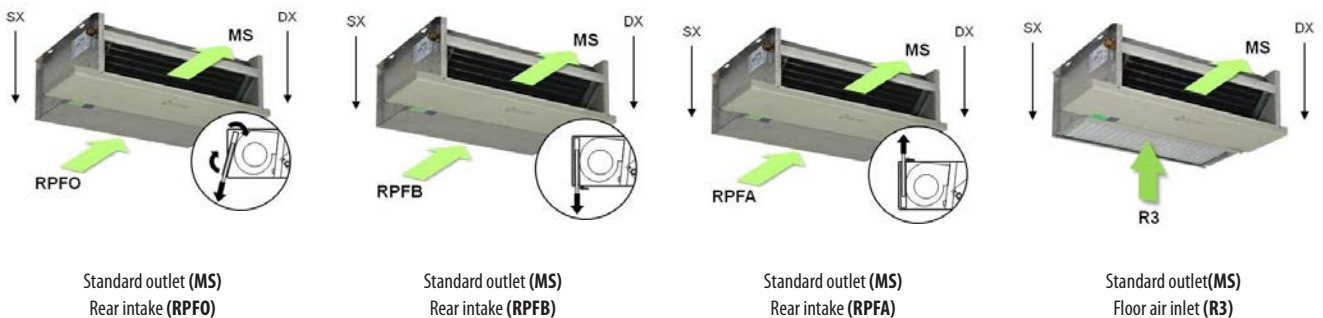

All ELFOSpace INH units are ductable (ESP up to 75Pa). For the rear intake with oblique downward filter extraction version (RPFO), to be able to duct the unit it's necessary to remove the filter and place it "upstream" of the unit, inside the duct.



References for position of fittings: right and left defined by standing in front of the unit (with the air blowing on your face).

# ELFOSpace OUTV configuration code - Vertical cased unit

(1)	(2)	(3)	(4)	(5)	(6)	(7)	(8)	(9)	(10)	(11)	(12)	(13)	(14)	(15)			
ELFOSpace	OUTV	003.0	230M	CC2	SX	VENS	MS	R3	TR	-	-	-	-	-			
		003.0 005.0 007.0 009.0 011.0 015.0 017.0 021.0 025.0 031.0 041.0 051.0	230M 230M	CC2 (Std) CC4	SX (Std) DX	VENS (Std) VEC	MS (Std)	R3 (Std) RF	TR (Std) TRM TRP TRMP HIDF1 HIDF2 HIDF4 HIDF5 HIDF6 HIDF7 HIDF8	- (Std) CTSP1	- (Std) CPVM	- (Std) RE	- (Std) CDP	- (Std) 2V2 2V4	- (Std) 3V2 3V4 10V2 10V4	- (Std) KBI2 KBI4	- (Std) BRV

## (1) Voltage

- 230M-Supply voltage 230/1/50

## (2) Coil configuration

- CC2 - Coil configuration for 2 pipe system
- CC4 - Coil configuration for 4 pipe system

## (3) Water fittings

- SX - Water fittings to the left (standard)
- DX - Water fittings to the right

## (4) Fans

- VENS - Standard AC fans (standard)
- VEC - High efficiency EC fan (available with options: TR, TRM, TRP, TRMP, CTSP1 + CPVM)

## (5) Air supply

- MS - Standard outlet (standard)

## (6) Air inlet

- R3 - Floor air inlet (standard)
- RF - Front air inlet

## (7) Controls keyboard

- TR - Terminal block for motor connection (standard)
- TRM - Terminal block with minimum water temperature clickson
- TRP - Terminal block with closing cover IP40.
- TRMP - Terminal block with closing cover IP40 and minimum water temperature clickson
- HIDF1 - Control on the unit: off + 3 speed switch
- HIDF2 - Control on the unit: BULB thermostat (3 speed + off + E/I + Temp.selection)
- HIDF4 - Control on the unit: BULB thermostat (3 speed + off + E/I + Temp.selection) + min. temperature thermostat
- HIDF5 - Control on the unit: BULB thermostat + on/off heaters
- HIDF6 - Control mounted on unit's side: multi-function electronic room thermostat
- HIDF7 - Built-in control: electronic thermostat with display
- HIDF8 - Control built-in installed: electronic thermostat with display for 3-speed or 0-10V fan and on/off or 0-10V valve

## (8) Electronic version

- (-) - Not required (standard)
- CTSP1 - CLIVET TALK TERMINAL SPACE electronics with RS485 Modbus serial port

## (9) Additional cards

- (-) - Not required (standard)
- CPVM - Control additional card of 0-10V valve and EC fan (available only with options: CTSP1)

## (10) Electric heaters

- (-) - Not required (standard)
- RE - Electric heaters

## (11) Condensate drain pump

- (-) - Not required (standard)
- CDP - Condensate drain pump

## (12) 2-way valves

- (-) - Not required (standard)
- 2V2 - ON/OFF 2-way valve kit for 2 pipe system
- 2V4 - ON/OFF 2 way on/off valve kit for 4 pipe system

## (13) 3-way valves

- (-) - Not required (standard)
- 3V2 - Three-way valve kit for 2 pipe type "on/off" system
- 3V4 - Three-way valve kit for 4 pipe type "on/off" system
- 10V2 - 0-10V 3-way valve kit for 2 pipe system
- 10V4 - 0-10V 3 way valve kit for 4 pipe system

## (14) Water balancing kit

- (-) - Not required (standard)
- KBI2 - 2 pipe water balancing kit = ball valve+water balancing kit
- KBI4 - 4 pipe water balancing kit = 2 ball valves+2 water balancing kit

## (15) Auxiliary condensate collection tray

- (-) - Not required (standard)
- BRV - Auxiliary condensate collection pan (vertical installation)

## ELFOSpace OUTV versions - Vertical cased unit

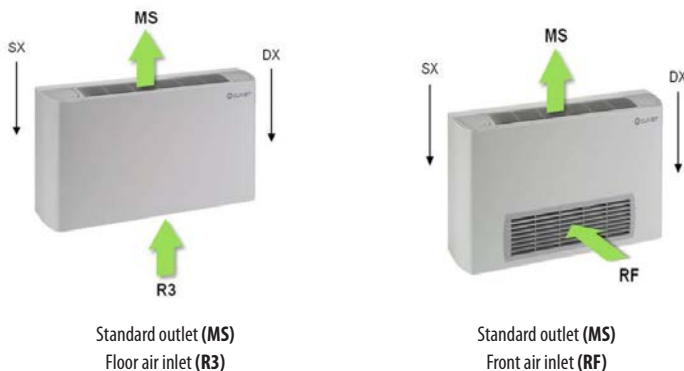

References for position of fittings: right and left defined by standing in front of the unit (with the air blowing on your face).

# ELFOSpace OUTH configuration code - Horizontal cased unit

ELFOSpace	OUTH	(1)	(2)	(3)	(4)	(5)	(6)	(7)	(8)	(9)	(10)	(11)	(12)	(13)	(14)	(15)
003.0	230M	CC2 (Std)	SX (Std)	VENS (Std)	MS (Std)	RP (Std)	TR (Std)	- (Std)	- (Std)	- (Std)	- (Std)	- (Std)	- (Std)	- (Std)	- (Std)	- (Std)
005.0	230M	CC4	DX	VEC	MS (Std)	R3	TRM	CTSP1	CPVM	RE	CDP	2V2	3V2	KBI2	-	-
007.0							TRP					2V4	3V4	KBI4		
009.0							TRMP						10V2			BROP
011.0													10V4			
015.0																
017.0																
021.0																
025.0																
031.0																
041.0																
051.0																

### (1) Voltage

- 230M-Supply voltage 230/1/50

### (2) Coil configuration

- CC2 - Coil configuration for 2 pipe system (standard)
- CC4 - Coil configuration for 4 pipe system

### (3) Water fittings

- SX - Water fittings to the left (standard)
- DX - Water fittings to the right

### (4) Fans

- VENS - Standard AC fans (standard)
- VEC - High efficiency EC fan (available with options: TR, TRM, TRP, TRMP, CTSP1 + CPVM)

### (5) Air supply

- MS - Standard outlet (standard)

### (6) Air inlet

- RP - Rear intake (standard)
- R3 - Floor air inlet

### (7) Controls keyboard

- TR - Terminal block for connection motor (standard)
- TRM - Terminal block with minimum water temperature clickson
- TRP - Terminal block with closing cover IP40.
- TRMP - Terminal block with closing cover IP40 and minimum water temperature clickson

### (8) Electronic version

- (-) - Not required (standard)
- CTSP1 - CLIVET TALK TERMINAL SPACE electronics with RS485 Modbus serial port

### (9) Additional cards

- (-) - Not required (standard)
- CPVM - Control additional card of 0-10V valve and EC fan (available only with options: CTSP1)

### (10) Electric heaters

- (-) - Not required (standard)
- RE - Electric heaters

### (11) Condensate drain pump

- (-) - Not required (standard)
- CDP - Condensate pump

### (12) 2-way valves

- (-) - Not required (standard)
- 2V2 - ON/OFF 2-way valve kit for 2 pipe system
- 2V4 - ON/OFF 2 way valve kit for 4 pipe system

### (13) 3-way valves

- (-) - Not required (standard)
- 3V2 - Three-way valve kit for 2-pipe type "on/off" system
- 3V4 - Three-way valve kit for 4 pipe type "on/off" system
- 10V2 - 0-10V 3-way valve kit for 2 pipe system
- 10V4 - 0-10V 3 way valve kit for 4 pipe system

### (14) Water balancing kit

- (-) - Not required (standard)
- KBI2 - 2 pipe water balancing kit = ball valve+water balancing kit
- KBI4 - 4 pipe water balancing kit = 2 ball valves+2 water balancing kit

### (15) Auxiliary condensate collection tray

- (-) - Not required (standard)
- BROP - Auxiliary drain pan (horizontal installation)

## ELFOSpace OUTH versions - Horizontal cased unit

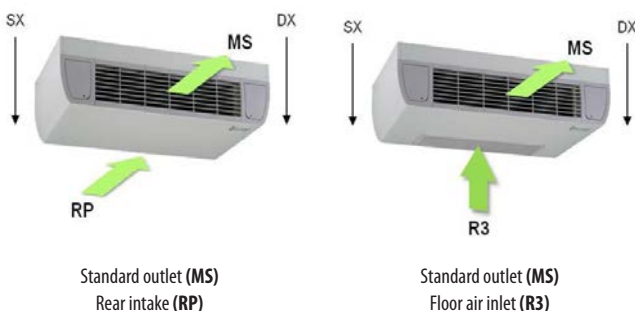

References for position of fittings: right and left defined by standing in front of the unit (with the air blowing on your face).



## Accessories separately supplied

- HIDE2X - Remote control with E/I + 3V + on/off for wall installation
- HIDE3X - Plurifunctional remote control for wall installation
- HIDE4X - Plurifunctional room control for 0-10V valves
- HIDE2X - HID-T2 electronic room control
- HIDE3X - HID-T3 electronic room control
- HIDE4X - HID-TI8X electronic room control for 3-speed or 0-10V fan and on/off or 0-10V valve
- DCPX - Control device for more units with a single room control.
- PTABX - Remote probe for room air temperature for electromechanical thermostats.
- CDPX - Condensate drain pump
- 2V2X - ON/OFF 2 way valve kit for 2 pipe system
- 2V4X - ON/OFF 2 way valve kit for 4 pipe system
- 3V2X - Three-way valve kit for 2 pipe type "on/off" system
- 3V4X - Three-way valve kit for 4 pipe type "on/off" system
- 10V2X - 0-10V 3-way valve kit for 2 pipe system
- 10V4X - 0-10V 3-way valve kit for 4 pipe system
- KBI2X - 2 pipe water balancing kit = ball valve+water balancing kit
- KBI4X - 4 pipe water balancing kit = 2 ball valves+2 water balancing kit
- KR90X - 90° pipe-fitting kit
- BRVX - Auxiliary condensate collection pan (vertical installation)
- BROPX - Auxiliary drain pan (horizontal installation)
- SERX - Manual outside air damper for vertical and horizontal installation
- SERMX - Outdoor air motorized on/off damper
- PRTX - 0-100 mm telescopic extension
- PRMX - Air discharge plenum
- PRAX - Air intake straight plenum
- PRCTX - Terminal plenum with circular connections
- PRCMX - Air outlet plenum with circular fittings + internal thermal and acoustic insulation
- PRCAX - Air intake plenum with circular fittings and air filter
- PR90MX - 90° air outlet plenum
- PR90AX - 90° air intake plenum
- AGRMX - Air outlet grille in aluminium without filter
- AGRAX - Air intake grille with air filter
- GRMX - Air outlet grille without air filter
- GRAX - Return grille with filter
- DAOJX - Air supply duct with flexible connection
- GAAX - Air intake duct with flexible connection
- TMX - Hot water min. temperature thermostat
- PI90X - Support feet for built-in vertical units h=90mm
- PI155X - Support plinth for concealed vertical units h=155mm
- PV90X - Support plinth with cover for in-view vertical units h=90mm
- PV155X - Support plinth with cover for in-view vertical units h=155mm
- PVG155X - Support feet with cover h=155mm and return grille
- FTZX - Galvanized steel plate falseframe
- PNAX - Pre-painted panel with supply and return grilles
- PPVX - Rear cover panel for OUTV without support feet
- PPV90X - Rear cover panel for OUTV with support feet h=90mm
- PPV155X - Rear cover panel for OUTV with support feet h=155mm

# Summary of accessories / configurations

		ELFOSpace		OUT		NOTE
		Type of installation		V	H	
CONFIGURATIONS VARIATIONS						
CC2	Coil configuration for 2 pipe system	STD	STD	STD	STD	
CC4	Coil configuration for 4 pipe system	C	C	C	C	
ELECTRIC CIRCUIT VARIATIONS						
TR	Terminal block for motor connection	C	C	C	C	
TRM	Terminal block with minimum water temperature clickson	C	C	C	C	
TRP	Terminal block with closing cover IP40	C	C	C	C	
TRMP	Terminal block with closing cover IP40 and minimum water temperature clickson	C	C	C	C	
CTSP1	CLIVET TALK TERMINAL SPACE electronics with RS485 Modbus serial port	C	C	C	C	
CPVM	Control additional card of 0-10V valve and EC fan (available only with options: CTSP1)	C	C	C	C	
HIDF1	Control on the unit: off + 3 speed switch	C	-	C	-	
HIDF2	Built-in control: BULB thermostat (3 speed + off + E/I + Temp.selection)	C	-	C	-	
HIDF4	Control on the unit: BULB thermostat (3 speed + off + E/I + Temp.select.) + min. temperature thermostat	C	-	C	-	
HIDF5	Control on the unit: BULB thermostat + on/off heaters	C	-	C	-	
HIDF6	Control mounted on unit's side: multi-function electronic room thermostat	C	-	C	-	
HIDF7	Built-in control: electronic thermostat with display	C	-	C	-	
HIDF8	Control built-in installed: electronic thermostat with display for 3-speed or 0-10V fan and on/off or 0-10V valve	C	-	C	-	
HIDE2X	Remote control with E/I + 3V + on/off for wall installation	A	A	A	A	
HIDE3X	Plurifunctional remote control for wall installation	A	A	A	A	
HIDE4X	Plurifunctional room control for 0-10V valves	A	A	A	A	
HIDT2X	HID-T2 electronic room control	A	A	A	A	
HIDT3X	HID-T3 electronic room control	A	A	A	A	
HIDT8X	HID-T18X electronic room control for 3-speed or 0-10V fan and on/off or 0-10V valve	A	A	A	A	
DCPX	Control device for more units with a single room control	A	A	A	A	
PTABX	Remote probe for room air temperature for electromechanical thermostats	A	A	A	A	
RE	Electric heaters	C	C	C	C	
WATER CIRCUIT VARIATIONS						
SX	Water fittings to the left	STD	STD	STD	STD	
DX	Water fittings to the right	C	C	C	C	
CDP	Condensate drain pump	CA	CA	CA	CA	
2V2	ON/OFF 2 way valve kit for 2 pipe system	CA	CA	CA	CA	
2V4	ON/OFF 2 way valve kit for 4 pipe system	CA	CA	CA	CA	
3V2	Three-way valve kit for 2 pipe type "on/off" system	CA	CA	CA	CA	
3V4	Three-way valve kit for 4 pipe type "on/off" system	CA	CA	CA	CA	
10V2	0-10V 3-way valve kit for 2 pipe system	CA	CA	CA	CA	
10V4	0-10V 3-way valve kit for 4 pipe system	CA	CA	CA	CA	
KBI2	2 pipe water balancing kit = ball valve+water balancing kit	CA	CA	CA	CA	
KBI4	4 pipe water balancing kit = 2 ball valves+2 water balancing kit	CA	CA	CA	CA	
KR90X	90° pipe-fitting kit	A	A	A	A	
BRV	Auxiliary condensate collection pan (vertical installation)	CA	-	CA	-	
BR0P	Auxiliary condensate collection pan (horizontal installation)	-	CA	-	CA	
TMX	Hot water min. temperature thermostat	A	A	A	A	
AIR SIDE FEATURES VARIATIONS						
MS	Standard outlet	STD	STD	STD	STD	
MR	90° air outlet	C	-	-	-	
R3	Floor air inlet	STD	C	STD	C	
RP	Rear intake	-	-	-	STD	
RPFO	Rear intake with oblique downward filter extraction	-	STD	-	-	
RPFB	Rear intake with vertical downward filter extraction	-	C	-	-	
RPFA	Rear intake with vertical upward filter extraction	-	C	-	-	
RF	Front air inlet	C	-	C	-	
VEVS	Standard AC fan	STD	STD	STD	STD	
VEC	High efficiency EC fan (available with options: TR, TRM, TRP, TRMP, CTSP1 + CPVM)	C	C	C	C	
SERX	Manual outside air damper for vertical and horizontal installation	A	A	A	A	Not available for size 041.0 and 051.0
SERMX	Outdoor air motorized on/off damper	A	A	A	A	
PRTX	0-100 mm telescopic extension	A	A	-	-	
PRMX	Air discharge plenum	A	A	-	-	
PRAX	Air intake straight plenum	A	A	-	-	
PRCTX	Terminal plenum with circular connections	A	A	-	-	
PRCMX	Air outlet plenum with circular fittings + internal thermal and acoustic insulation	A	A	-	-	
PRCAX	Air intake plenum with circular fittings and air filter	A	A	-	-	
PR90MX	90° air outlet plenum	A	A	-	-	
PR90AX	90° air intake plenum	A	A	-	-	
AGRMX	Air outlet grille in aluminium without filter	A	A	-	-	
AGRAX	Air intake grille with air filter	A	A	-	-	
GRMX	Air outlet grille without air filter	A	A	-	-	
GRAX	Return grille with filter	A	A	-	-	
DAOJX	Air supply duct with flexible connection	A	A	-	-	
GAAX	Air intake duct with flexible joint	A	A	-	-	
INSTALLATION VARIATIONS						
PI90X	Support feet for built-in vertical units h=90mm	A	-	-	-	
PI155X	Support plinth for concealed vertical units h=155mm	A	-	-	-	
PV90X	Support plinth with cover for in-view vertical units h=90mm	-	-	A	-	
PV155X	Support plinth with cover for in-view vertical units h=155mm	-	-	A	-	
PVG155X	Support feet with cover h=155mm and return grille	-	-	A	-	
FTZX	Galvanized steel plate falseframe	A	A	-	-	
PNAX	Pre-painted panel with supply and return grilles	A	A	-	-	
PPVX	Rear cover panel for OUTV without support feet	-	-	A	A	
PPV90X	Rear cover panel for OUTV with support feet h=90mm	-	-	A	A	
PPV155X	Rear cover panel for OUTV with support feet h=155mm	-	-	A	A	

STD = STANDARD CONFIGURATION

C = ONLY CONFIGURATION (unit supplied with installed component)

CA = CONFIGURATION OR ACCESSORY (unit supplied with installed component or separated)

A = ONLY ACCESSORY (separately supplied)

## General technical data - 2 pipe system (CC2)

### VENS - Standard AC fan

Size			003.0	005.0	007.0	009.0	011.0	015.0	017.0	021.0	025.0	031.0	041.0	051.0
<b>Cooling</b>														
Cooling capacity	(1)	[kW]	1,5	2,0	2,53	3,02	3,75	4,25	5,52	6,42	7,53	9,02	9,6	10,71
Sensible capacity	(1)	[kW]	1,29	1,62	2,07	2,31	2,87	3,23	4,33	4,80	5,67	6,62	7,64	8,36
Total power input	(1)	[kW]	0,055	0,055	0,085	0,085	0,075	0,075	0,145	0,145	0,175	0,175	0,285	0,285
<b>Heating</b>														
Heating capacity	(2)	[kW]	3,74	4,91	5,98	6,71	8,16	9,44	12,0	13,3	15,5	18,1	21,1	23,2
<b>Internal exchanger</b>														
Number of rows		[Nr]	3	3	3	3	3	3	3	3	3	3	3	3
Water volume		[l]	0,69	0,7	0,99	1,01	1,3	1,31	1,6	1,62	1,91	1,92	2,21	2,23
Water flow-rate	(1)	[l/s]	0,07	0,1	0,12	0,14	0,18	0,2	0,26	0,31	0,36	0,43	0,46	0,51
Water pressure drops	(1)	[kPa]	13,1	16,3	18,5	20,8	22,6	24,1	24,5	27,1	28,8	29,2	31	33,4
Water pressure drops	(2)	[kPa]	15,9	19,2	20,1	20	20,9	23,2	22,6	22,7	23,8	22,9	29,2	30,6
<b>Air handling section fans (supply)</b>														
Type of fans	(3)		CFG	CFG	CFG	CFG	CFG	CFG	CFG	CFG	CFG	CFG	CFG	CFG
Number of fans		[Nr]	1	1	1	1	2	2	2	2	2	2	3	3
Air flow	(4)	[l/s]	103	111	139	153	186	200	278	292	356	364	531	539
Air flow	(4)	[m³/h]	370	400	500	550	670	720	1000	1050	1280	1310	1910	1940
Max external static pressure		[Pa]	86	86	86	86	98	98	103	103	113	113	119	119
<b>Connections</b>														
Water fittings		["]	1/2" F	1/2" F	1/2" F	1/2" F	1/2" F	1/2" F	1/2" F	1/2" F	1/2" F	1/2" F	1/2" F	1/2" F
Condensate drain	(5)	[mm]	20	20	20	20	20	20	20	20	20	20	20	20
<b>Noise levels</b>														
Sound pressure level (1m)	(6)	[dB(A)]	44	44	50	51	43	43	49	51	54	55	57	57
Sound power Level	(6)	[dB(A)]	55	55	61	62	54	54	60	62	65	66	68	68
<b>Power supply</b>														
Power supply STD		[V]	230/1/50	230/1/50	230/1/50	230/1/50	230/1/50	230/1/50	230/1/50	230/1/50	230/1/50	230/1/50	230/1/50	230/1/50

The Product is compliant with the Erp (Energy Related Products) European Directive. It includes the Commission delegated Regulation (EU) No 2016/2281, also known as Ecodesign Lot21.  
 \*Contains fluorinated greenhouse gases\*(GWP 2087,5)

(1) Indoor air at 27°C D.B/19 C.W.B  
 Water temperature in / out 7°C / 12°C  
 Air flow at maximum speed (ESP = 0Pa)  
 (2) Indoor air temperature at 20°C  
 Water inlet 70°C and outlet 60°C  
 Air flow at maximum speed (ESP = 0Pa)

(3) CFG = AC centrifugal fan  
 (4) Air flow at maximum speed - (ESP = 0Pa)  
 (5) Intended as an external diameter  
 (6) The sound pressure level is measured 1 m from the external surface of the wall mounted in view unit, for the built-in it is possible a sound pressure reduction of 2 dB or higher. The determination of the sound pressure levels has been made with respect to the UNI-EN-ISO 3744 certification.

## Electrical data - 2 pipe system (CC2)

### VENS - Standard AC fan

Voltage 230/1/50 ± 10%

Size			003.0	005.0	007.0	009.0	011.0	015.0	017.0	021.0	025.0	031.0	041.0	051.0
<b>F.L.A. Full load current at max admissible conditions</b>														
F.L.A. Total		[A]	0,25	0,25	0,40	0,40	0,35	0,35	0,65	0,65	0,77	0,77	1,30	1,30
<b>F.L.I. - Full load power input at max admissible conditions</b>														
F.L.I. Total		[kW]	0,055	0,055	0,085	0,085	0,075	0,075	0,145	0,145	0,175	0,175	0,285	0,285

(1) Indoor air at 27°C D.B/19 C.W.B  
 Water temperature in / out 7°C / 12°C  
 Air flow at maximum speed (ESP = 0Pa)  
 (2) Indoor air temperature at 20°C  
 Water inlet 70°C and outlet 60°C  
 Air flow at maximum speed (ESP = 0Pa)

# General technical data - 4 pipe system (CC4)

## VENS - Standard AC fan

Size			003.0	005.0	007.0	009.0	011.0	015.0	017.0	021.0	025.0	031.0	041.0	051.0
<b>Cooling</b>														
Cooling capacity	(1)	[kW]	1,45	1,94	2,47	2,92	3,65	4,11	5,39	6,23	7,35	8,81	9,42	10,51
Sensible capacity	(1)	[kW]	1,24	1,57	2,02	2,22	2,78	3,11	4,21	4,64	5,52	6,44	7,47	8,18
Total power input	(1)	[kW]	0,055	0,055	0,085	0,085	0,075	0,075	0,145	0,145	0,175	0,175	0,285	0,285
<b>Heating</b>														
Heating capacity	(2)	[kW]	1,88	1,98	3,18	3,35	4,38	4,55	6,29	6,46	7,99	8,11	11,09	11,2
<b>Internal exchanger</b>														
Number of rows		[Nr]	3+1	3+1	3+1	3+1	3+1	3+1	3+1	3+1	3+1	3+1	3+1	3+1
Water volume main coil		[l]	0,69	0,7	0,99	1,01	1,3	1,31	1,6	1,62	1,91	1,92	2,21	2,23
Water volume additional coil		[l]	0,23	0,23	0,33	0,33	0,43	0,43	0,54	0,54	0,64	0,64	0,74	0,74
Water flow-rate	(1)	[l/s]	0,07	0,09	0,12	0,14	0,17	0,2	0,26	0,3	0,35	0,42	0,45	0,5
Water pressure drops	(1)	[kPa]	12,3	15,4	17,6	19,5	21,4	22,5	23,4	25,5	27,4	27,9	29,8	32,1
Water pressure drops	(2)	[kPa]	7,3	8,1	11,7	13	21,3	23	41,1	43,4	37,8	38,9	48,4	49,4
<b>Air handling section fans (supply)</b>														
Type of fans	(3)		CFG	CFG	CFG	CFG	CFG	CFG	CFG	CFG	CFG	CFG	CFG	CFG
Number of fans		[Nr]	1	1	1	1	2	2	2	2	2	2	3	3
Air flow	(4)	[l/s]	97	106	133	144	178	189	267	278	342	350	514	522
Air flow	(4)	[m³/h]	350	380	480	520	640	680	960	1000	1230	1260	1850	1880
Max external static pressure		[Pa]	86	86	86	86	98	98	104	104	113	113	119	119
<b>Connections</b>														
Water fittings main coil		["]	1/2" F	1/2" F	1/2" F	1/2" F	1/2" F	1/2" F	1/2" F	1/2" F	1/2" F	1/2" F	1/2" F	1/2" F
Water fittings additional coil		["]	1/2" F	1/2" F	1/2" F	1/2" F	1/2" F	1/2" F	1/2" F	1/2" F	1/2" F	1/2" F	1/2" F	1/2" F
Condensate drain	(5)	[mm]	20	20	20	20	20	20	20	20	20	20	20	20
<b>Noise levels</b>														
Sound pressure level (1m)	(6)	[dB(A)]	44	44	50	51	43	43	49	51	54	55	57	57
Sound Power Level	(6)	[dB(A)]	55	55	61	62	54	54	60	62	65	66	68	68
<b>Power supply</b>														
Power supply STD		[V]	230/1/50	230/1/50	230/1/50	230/1/50	230/1/50	230/1/50	230/1/50	230/1/50	230/1/50	230/1/50	230/1/50	230/1/50

The Product is compliant with the Erp (Energy Related Products) European Directive. It includes the Commission delegated Regulation (EU) No 2016/2281, also known as Ecodesign Lot21.

\*Contains fluorinated greenhouse gases (GWP 2087,5)

(1) Indoor air at 27°C D.B./19 C.W.B  
 Water temperature in / out 7°C / 12°C  
 Air flow at maximum speed (ESP = 0Pa)  
 (2) Indoor air temperature at 20°C  
 Water inlet 70°C and outlet 60°C  
 Air flow at maximum speed (ESP = 0Pa)

(3) CFG = AC centrifugal fan  
 (4) Air flow at maximum speed - (ESP = 0Pa)  
 (5) Intended as an external diameter  
 (6) The sound pressure level is measured 1 m from the external surface of the wall mounted in view unit, for the built-in it is possible a sound pressure reduction of 2 dB or higher. The determination of the sound pressure levels has been made with respect to the UNI-EN-ISO 3744 certification.

# Electrical data - 4 pipe (CC4)

## VENS - Standard AC fan

Voltage 230/1/50 ± 10%

Size			003.0	005.0	007.0	009.0	011.0	015.0	017.0	021.0	025.0	031.0	041.0	051.0
<b>F.L.A. Full load current at max admissible conditions</b>														
F.L.A. Total	[A]		0,25	0,25	0,4	0,4	0,35	0,35	0,65	0,65	0,77	0,77	1,3	1,3
<b>F.L.I. - Full load power input at max admissible conditions</b>														
F.L.I. Total	[kW]		0,055	0,055	0,085	0,085	0,075	0,075	0,145	0,145	0,175	0,175	0,285	0,285

(1) Indoor air at 27°C D.B./19 C.W.B  
 Water temperature in / out 7°C / 12°C  
 Air flow at maximum speed (ESP = 0Pa)  
 (2) Indoor air temperature at 20°C  
 Water inlet 70°C and outlet 60°C  
 Air flow at maximum speed (ESP = 0Pa)

# Operating range

## 2 pipe system (CC2) and 4 pipe system (CC4)

Size		003.0	005.0	007.0	009.0	011.0	015.0	017.0	021.0	025.0	031.0	041.0	051.0
<b>Heating</b>													
Max water inlet temperature	[°C]	80	80	80	80	80	80	80	80	80	80	80	80
Max water outlet temperature	[°C]	2	2	2	2	2	2	2	2	2	2	2	2
Max. air inlet temperature (D.B.)	[°C]	40	40	40	40	40	40	40	40	40	40	40	40
Max. air outlet temperature (D.B.)	[°C]	2	2	2	2	2	2	2	2	2	2	2	2
<b>Cooling</b>													
Max. air inlet temperature (WB)	[°C]	40	40	40	40	40	40	40	40	40	40	40	40
Min air inlet temperature (W.B.)	[°C]	2	2	2	2	2	2	2	2	2	2	2	2
Max water side pressure	[bar]	30	30	30	30	30	30	30	30	30	30	30	30



Max water side pressure = Coil max pressure. In presence of accessories (for example 2-3 way valves) the max water side pressure is 15 bar.

## Exchanger pressure drops

### 2 pipe system

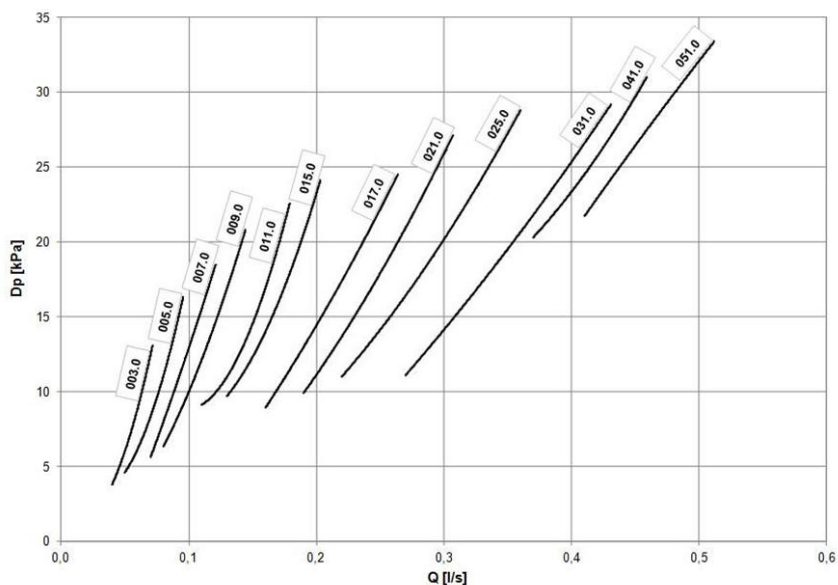

Q = Water flow rate (l/s)  
DP = Pressure drops [kPa]

### 4 pipe system

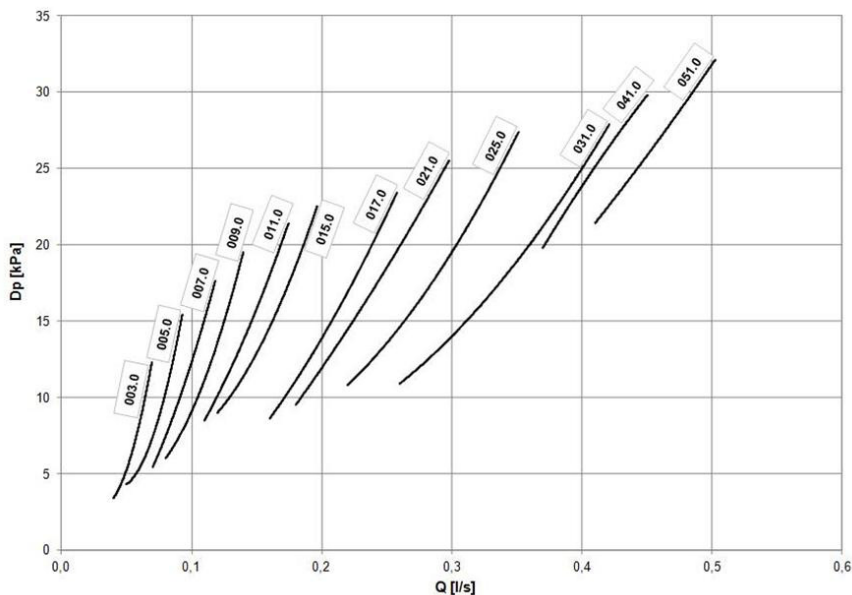

Q = Water flow rate (l/s)  
DP = Pressure drops [kPa]

# Sound levels

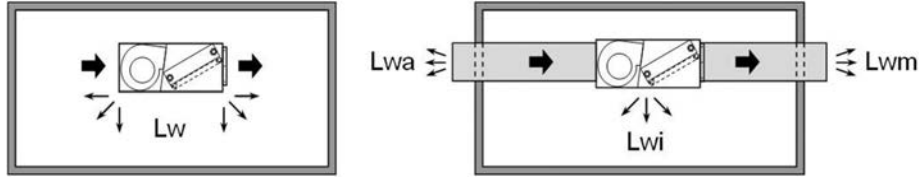

- Lw** Total sound power emitted by the unit
- Lwi** Radiated sound power, emitted by the lateral surfaces of the unit
- Lwm** Sound power emitted by the air supply side of the unit
- Lwa** Sound power emitted by the air intake side of the unit

## Size 003.0 (CC2-CC4)

Static pressure	Sound power	Fan speed	Sound power level (dB)							Sound pressure level	Sound power level
			Octave band (Hz)								
			125	250	500	1000	2000	4000	8000		
0 Pa	Lw	Min	42,2	43,0	41,4	33,3	27,3	23,5	17,7	30	41
		Mid	46,6	48,2	47,5	41,0	37,3	29,3	18,3	37	48
		Max	52,7	54,2	53,6	48,6	45,7	40,7	30,4	44	55
	Lwi	Min	24,3	22,4	15,8	5,0	n.m.	n.m.	n.m.	6	17
		Mid	28,8	27,7	21,9	12,8	n.m.	n.m.	n.m.	12	23
		Max	34,9	33,7	28,1	20,3	11,3	n.m.	n.m.	18	29
	Lwm	Min	39,3	39,8	35,5	29,2	25,1	20,7	14,6	26	37
		Mid	43,7	45,1	41,6	36,9	35,1	26,5	15,2	32	43
		Max	49,8	51,1	47,8	44,5	43,6	37,9	27,3	40	51
	Lwa	Min	38,9	40,0	40,0	31,2	23,2	20,2	14,7	28	39
		Mid	43,3	45,2	46,1	38,9	33,2	26,0	15,3	35	46
		Max	49,4	51,2	52,3	46,5	41,7	37,5	27,4	41	52
25 Pa	Lw	Min	43,1	43,9	42,3	34,2	28,2	24,4	18,6	31	42
		Mid	47,5	49,1	48,4	41,9	38,2	30,2	19,2	38	49
		Max	53,6	55,1	54,5	49,5	46,6	41,6	31,3	45	56
	Lwi	Min	25,2	23,3	16,7	5,9	n.m.	n.m.	n.m.	7	18
		Mid	29,7	28,6	22,8	13,7	n.m.	n.m.	n.m.	13	24
		Max	35,8	34,6	29,0	21,2	12,2	n.m.	n.m.	19	30
	Lwm	Min	40,2	40,7	36,4	30,1	26,0	21,6	15,5	27	38
		Mid	44,6	46,0	42,5	37,8	36,0	27,4	16,1	33	44
		Max	50,7	52,0	48,7	45,4	44,5	38,8	28,2	41	52
	Lwa	Min	39,8	40,9	40,9	32,1	24,1	21,1	15,6	29	40
		Mid	44,2	46,1	47,0	39,8	34,1	26,9	16,2	35	46
		Max	50,3	52,1	53,2	47,4	42,6	38,4	28,3	42	53
50 Pa	Lw	Min	44,0	44,8	43,2	35,1	29,1	25,3	19,5	32	43
		Mid	48,4	50,0	49,3	42,8	39,1	31,1	20,1	38	49
		Max	54,5	56,0	55,4	50,4	47,5	42,5	32,2	45	56
	Lwi	Min	26,1	24,2	17,6	6,8	n.m.	n.m.	n.m.	8	19
		Mid	30,6	29,5	23,7	14,6	n.m.	n.m.	n.m.	14	25
		Max	36,7	35,5	29,9	22,1	13,1	n.m.	n.m.	20	31
	Lwm	Min	41,1	41,6	37,3	31,0	26,9	22,5	16,4	27	38
		Mid	45,5	46,9	43,4	38,7	36,9	28,3	17,0	34	45
		Max	51,6	52,9	49,6	46,3	45,4	39,7	29,1	41	52
	Lwa	Min	40,7	41,8	41,8	33,0	25,0	22,0	16,5	30	41
		Mid	45,1	47,0	47,9	40,7	35,0	27,8	17,1	36	47
		Max	51,2	53,0	54,1	48,3	43,5	39,3	29,2	43	54
75 Pa	Lw	Min	44,9	45,7	44,1	36,0	30,0	26,2	20,4	33	44
		Med	49,3	50,9	50,2	43,7	40,0	32,0	21,0	39	50
		Max	55,4	56,9	56,3	51,3	48,4	43,4	33,1	46	57
	Lwi	Min	27,0	25,1	18,5	7,7	n.m.	n.m.	n.m.	9	20
		Mid	31,5	30,4	24,6	15,5	n.m.	n.m.	n.m.	15	26
		Max	37,6	36,4	30,8	23,0	14,0	n.m.	n.m.	21	32
	Lwm	Min	42,0	42,5	38,2	31,9	27,8	23,4	17,3	28	39
		Mid	46,4	47,8	44,3	39,6	37,8	29,2	17,9	35	46
		Max	52,5	53,8	50,5	47,2	46,3	40,6	30,1	42	53
	Lwa	Min	41,6	42,7	42,7	33,9	25,9	22,9	17,4	31	42
		Mid	46,0	47,9	48,8	41,6	35,9	28,7	18,0	37	48
		Max	52,1	53,9	55,0	49,2	44,4	40,2	30,2	44	55

The sound pressure level is measured 1 metre from the external surface of the wall mounted in view unit. For the built-in unit it is possible a sound pressure reduction of 2 dB or higher. The determination of the sound pressure levels has been made with respect to the UNI-EN-ISO 3744 certification.  
n.m. = not measurable

## Sound levels

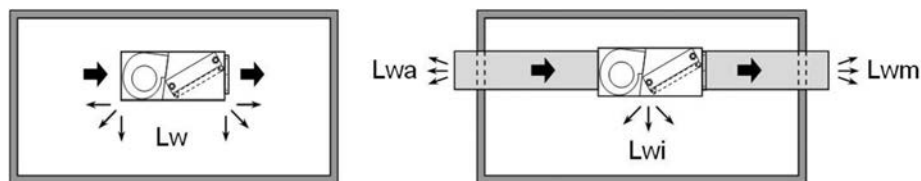

- Lw** Total sound power emitted by the unit
- Lwi** Radiated sound power, emitted by the lateral surfaces of the unit
- Lwm** Sound power emitted by the air supply side of the unit
- Lwa** Sound power emitted by the air intake side of the unit

### Size 005.0 (CC2-CC4)

Static pressure	Sound power	Fan speed	Sound power level (dB)							Sound pressure level dB(A)	Sound power level dB(A)
			Octave band (Hz)								
			125	250	500	1000	2000	4000	8000		
0 Pa	Lw	Min	42,6	42,7	42,1	34,0	28,0	24,2	18,4	31	42
		Mid	47,3	48,2	48,2	41,7	38,0	30,0	19,0	37	48
		Max	53,4	54,1	54,3	49,3	46,4	41,4	31,1	44	55
	Lwi	Min	24,8	22,2	16,5	5,7	n.m.	n.m.	n.m.	7	18
		Mid	29,5	27,7	22,6	13,5	n.m.	n.m.	n.m.	12	23
		Max	35,6	33,6	28,8	21,0	12,0	n.m.	n.m.	19	30
	Lwm	Min	39,7	39,6	36,2	29,9	25,8	21,4	15,3	26	37
		Mid	44,4	45,1	42,3	37,6	35,8	27,2	15,9	33	44
		Max	50,5	51,0	48,5	45,2	44,3	38,6	28,0	40	51
	Lwa	Min	39,3	39,8	40,7	31,9	23,9	20,9	15,4	29	40
		Mid	44,0	45,2	46,8	39,6	33,9	26,7	16,0	35	46
		Max	50,1	51,1	53,0	47,2	42,4	38,2	28,1	42	53
25 Pa	Lw	Min	42,6	42,7	42,1	34,0	28,0	24,2	20,2	31	42
		Mid	48,2	49,1	49,1	42,6	38,9	30,9	19,9	38	49
		Max	54,3	55,0	55,2	50,2	47,3	42,3	32,0	45	56
	Lwi	Min	24,8	22,2	16,5	5,7	n.m.	n.m.	n.m.	7	18
		Mid	30,4	28,6	23,5	14,4	n.m.	n.m.	n.m.	13	24
		Max	36,5	34,5	29,7	21,9	12,9	n.m.	n.m.	20	31
	Lwm	Min	39,7	39,6	36,2	29,9	25,8	21,4	17,1	26	37
		Mid	45,3	46,0	43,2	38,5	36,7	28,1	16,8	34	45
		Max	51,4	51,9	49,4	46,1	45,2	39,5	28,9	41	52
	Lwa	Min	39,3	39,8	40,7	31,9	23,9	20,9	17,2	29	40
		Mid	44,9	46,1	47,7	40,5	34,8	27,6	16,9	36	47
		Max	51,0	52,0	53,9	48,1	43,3	39,1	29,0	43	54
50 Pa	Lw	Min	44,4	44,5	43,9	35,8	29,8	26,0	20,2	32	43
		Mid	49,1	50,0	50,0	43,5	39,8	31,8	20,8	39	50
		Max	55,2	55,9	56,1	51,1	48,2	43,2	32,9	46	57
	Lwi	Min	26,6	24,0	18,3	7,5	n.m.	n.m.	n.m.	8	19
		Mid	31,3	29,5	24,4	15,3	5,3	n.m.	n.m.	14	25
		Max	37,4	35,4	30,6	22,8	13,8	n.m.	n.m.	20	31
	Lwm	Min	41,5	41,4	38,0	31,7	27,6	23,2	17,1	28	39
		Mid	46,2	46,9	44,1	39,4	37,6	29,0	17,7	35	46
		Max	52,3	52,8	50,3	47,0	46,1	40,4	29,9	42	53
	Lwa	Min	41,1	41,6	42,5	33,7	25,7	22,7	17,2	30	41
		Mid	45,8	47,0	48,6	41,4	35,7	28,5	17,8	37	48
		Max	51,9	52,9	54,8	49,0	44,2	40,0	30,0	44	55
75 Pa	Lw	Min	45,3	45,4	44,8	36,7	30,7	26,9	21,1	33	44
		Med	50,0	50,9	50,9	44,4	40,7	32,7	21,7	40	51
		Max	56,1	56,8	57,0	52,0	49,1	44,1	33,8	47	58
	Lwi	Min	27,5	24,9	19,2	8,4	n.m.	n.m.	n.m.	9	20
		Mid	32,2	30,4	25,3	16,2	6,2	n.m.	n.m.	15	26
		Max	38,3	36,3	31,5	23,7	14,7	n.m.	n.m.	21	32
	Lwm	Min	42,4	42,3	38,9	32,6	28,5	24,1	18,0	29	40
		Mid	47,1	47,8	45,0	40,3	38,5	29,9	18,6	36	47
		Max	53,2	53,7	51,2	47,9	47,0	41,3	30,8	43	54
	Lwa	Min	42,0	42,5	43,4	34,6	26,6	23,6	18,1	31	42
		Mid	46,7	47,9	49,5	42,3	36,6	29,4	18,7	38	49
		Max	52,8	53,8	55,7	49,9	45,1	40,9	30,9	45	56

The sound pressure level is measured 1 metre from the external surface of the wall mounted in view unit. For the built-in unit it is possible a sound pressure reduction of 2 dB or higher. The determination of the sound pressure levels has been made with respect to the UNI-EN-ISO 3744 certification.  
n.m.= not measurable

# Sound levels

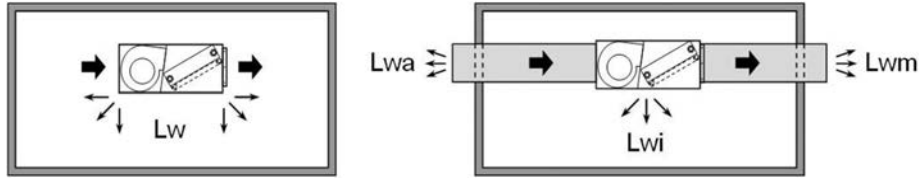

- Lw** Total sound power emitted by the unit
- Lwi** Radiated sound power, emitted by the lateral surfaces of the unit
- Lwm** Sound power emitted by the air supply side of the unit
- Lwa** Sound power emitted by the air intake side of the unit

## Size 007.0 (CC2-CC4)

Static pressure	Sound power	Fan speed	Sound power level (dB)							Sound pressure level	Sound power level
			Octave band (Hz)								
			125	250	500	1000	2000	4000	8000		
0 Pa	Lw	Min	49,3	46,4	47,3	41,2	36,6	28,6	21,8	36	47
		Mid	54,3	56,1	53,5	48,2	46,2	39,9	31,1	44	55
		Max	60,2	62,0	58,6	54,1	52,3	47,9	43,4	50	61
	Lwi	Min	31,5	25,9	21,8	13,0	n.m.	n.m.	n.m.	12	23
		Mid	36,5	35,6	28,0	19,9	11,7	n.m.	n.m.	19	30
		Max	42,4	41,5	33,1	25,8	17,8	8,0	n.m.	25	36
	Lwm	Min	46,4	43,3	41,5	37,1	34,4	25,8	18,7	32	43
		Mid	51,4	53,0	47,6	44,1	44,0	37,1	28,1	40	51
		Max	57,3	58,9	52,8	50,0	50,1	45,1	40,4	46	57
	Lwa	Min	46,0	43,4	46,0	39,1	32,5	25,4	18,8	34	45
		Mid	51,0	53,1	52,2	46,0	42,1	36,7	28,2	42	53
		Max	56,9	59,0	57,3	51,9	48,2	44,7	40,5	47	58
25 Pa	Lw	Min	50,2	47,3	48,2	42,1	37,5	29,5	22,7	37	48
		Mid	55,2	57,0	54,4	49,1	47,1	40,8	32,0	45	56
		Max	61,1	62,9	59,5	55,0	53,2	48,8	44,3	51	62
	Lwi	Min	32,4	26,8	22,7	13,9	n.m.	n.m.	n.m.	13	24
		Mid	37,4	36,5	28,9	20,8	12,6	n.m.	n.m.	20	31
		Max	43,3	42,4	34,0	26,7	18,7	8,9	n.m.	26	37
	Lwm	Min	47,3	44,2	42,4	38,0	35,3	26,7	19,6	33	44
		Mid	52,3	53,9	48,5	45,0	44,9	38,0	29,0	41	52
		Max	58,2	59,8	53,7	50,9	51,0	46,0	41,3	47	58
	Lwa	Min	46,9	44,3	46,9	40,0	33,4	26,3	19,7	35	46
		Mid	51,9	54,0	53,1	46,9	43,0	37,6	29,1	42	53
		Max	57,8	59,9	58,2	52,8	49,1	45,6	41,4	48	59
50 Pa	Lw	Min	51,1	48,2	49,1	43,0	38,4	30,4	23,6	38	49
		Mid	56,1	57,9	55,3	50,0	48,0	41,7	32,9	46	57
		Max	62,0	63,8	60,4	55,9	54,1	49,7	45,2	51	62
	Lwi	Min	33,3	27,7	23,6	14,8	n.m.	n.m.	n.m.	13	24
		Mid	38,3	37,4	29,8	21,7	13,5	n.m.	n.m.	21	32
		Max	44,2	43,3	34,9	27,6	19,6	9,8	n.m.	27	38
	Lwm	Min	48,2	45,1	43,3	38,9	36,2	27,6	20,5	34	45
		Mid	53,2	54,8	49,4	45,9	45,8	38,9	29,9	42	53
		Max	59,1	60,7	54,6	51,8	51,9	46,9	42,2	48	59
	Lwa	Min	47,8	45,2	47,8	40,9	34,3	27,2	20,6	36	47
		Mid	52,8	54,9	54,0	47,8	43,9	38,5	30,0	43	54
		Max	58,7	60,8	59,1	53,7	50,0	46,5	42,3	49	60
75 Pa	Lw	Min	52,0	49,1	50,0	43,9	39,3	31,3	24,5	39	50
		Med	57,0	58,8	56,2	50,9	48,9	42,6	33,8	47	58
		Max	62,9	64,7	61,3	56,8	55,0	50,6	46,1	52	63
	Lwi	Min	34,2	28,6	24,5	15,7	n.m.	n.m.	n.m.	14	25
		Mid	39,2	38,3	30,7	22,6	14,4	n.m.	n.m.	22	33
		Max	45,1	44,2	35,8	28,5	20,5	10,7	n.m.	27	38
	Lwm	Min	49,1	46,0	44,2	39,8	37,1	28,5	21,4	35	46
		Mid	54,1	55,7	50,3	46,8	46,7	39,8	30,8	43	54
		Max	60,0	61,6	55,5	52,7	52,8	47,8	43,1	49	60
	Lwa	Min	48,7	46,1	48,7	41,8	35,2	28,1	21,5	37	48
		Mid	53,7	55,8	54,9	48,7	44,8	39,4	30,9	44	55
		Max	59,6	61,7	60,0	54,6	50,9	47,4	43,2	50	61

The sound pressure level is measured 1 metre from the external surface of the wall mounted in view unit. For the built-in unit it is possible a sound pressure reduction of 2 dB or higher. The determination of the sound pressure levels has been made with respect to the UNI-EN-ISO 3744 certification.  
 n.m. = not measurable



## Sound levels

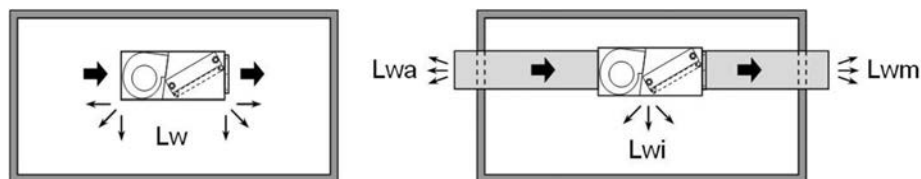

- Lw** Total sound power emitted by the unit
- Lwi** Radiated sound power, emitted by the lateral surfaces of the unit
- Lwm** Sound power emitted by the air supply side of the unit
- Lwa** Sound power emitted by the air intake side of the unit

### Size 009.0 (CC2-CC4)

Static pressure	Sound power	Fan speed	Sound power level (dB)							Sound pressure level	Sound power level
			Octave band (Hz)								
			125	250	500	1000	2000	4000	8000		
0 Pa	Lw	Min	47,6	50,1	48,0	41,9	37,3	29,3	22,5	37	48
		Mid	55,0	56,8	54,2	48,9	46,9	40,6	31,8	45	56
		Max	61,6	63,4	59,7	54,8	53,0	48,6	44,1	51	62
	Lwi	Min	29,8	29,6	22,5	13,7	n.m.	n.m.	n.m.	13	24
		Mid	37,2	36,3	28,7	20,6	12,4	n.m.	n.m.	20	31
		Max	43,8	42,9	34,1	26,5	18,5	8,7	n.m.	26	37
	Lwm	Min	44,7	47,0	42,2	37,8	35,1	26,5	19,4	33	44
		Mid	52,1	53,7	48,3	44,8	44,7	37,8	28,8	41	52
		Max	58,7	60,3	53,8	50,7	50,8	45,8	41,1	47	58
	Lwa	Min	44,3	47,1	46,7	39,8	33,2	26,1	19,5	35	46
		Mid	51,7	53,8	52,9	46,7	42,8	37,4	28,9	42	53
		Max	58,3	60,4	58,3	52,6	48,9	45,4	41,2	48	59
25 Pa	Lw	Min	48,5	51,0	48,9	42,8	38,2	30,2	23,4	38	49
		Mid	55,9	57,7	55,1	49,8	47,8	41,5	32,7	45	56
		Max	62,5	64,3	60,6	55,7	53,9	49,5	45,0	52	63
	Lwi	Min	30,7	30,5	23,4	14,6	n.m.	n.m.	n.m.	14	25
		Mid	38,1	37,2	29,6	21,5	13,3	n.m.	n.m.	21	32
		Max	44,7	43,8	35,0	27,4	19,4	9,6	n.m.	27	38
	Lwm	Min	45,6	47,9	43,1	38,7	36,0	27,4	20,3	34	45
		Mid	53,0	54,6	49,2	45,7	45,6	38,7	29,7	42	53
		Max	59,6	61,2	54,7	51,6	51,7	46,7	42,0	48	59
	Lwa	Min	45,2	48,0	47,6	40,7	34,1	27,0	20,4	36	47
		Mid	52,6	54,7	53,8	47,6	43,7	38,3	29,8	43	54
		Max	59,2	61,3	59,2	53,5	49,8	46,3	42,1	49	60
50 Pa	Lw	Min	49,4	51,9	49,8	43,7	39,1	31,1	24,3	39	50
		Mid	56,8	58,6	56,0	50,7	48,7	42,4	33,6	46	57
		Max	63,4	65,2	61,5	56,6	54,8	50,4	45,9	52	63
	Lwi	Min	31,6	31,4	24,3	15,5	n.m.	n.m.	n.m.	15	26
		Mid	39,0	38,1	30,5	22,4	14,2	n.m.	n.m.	22	33
		Max	45,6	44,7	35,9	28,3	20,3	10,5	n.m.	28	39
	Lwm	Min	46,5	48,8	44,0	39,6	36,9	28,3	21,2	35	46
		Mid	53,9	55,5	50,1	46,6	46,5	39,6	30,6	42	53
		Max	60,5	62,1	55,6	52,5	52,6	47,6	42,9	49	60
	Lwa	Min	46,1	48,9	48,5	41,6	35,0	27,9	21,3	37	48
		Mid	53,5	55,6	54,7	48,5	44,6	39,2	30,7	44	55
		Max	60,1	62,2	60,1	54,4	50,7	47,2	43,0	50	61
75 Pa	Lw	Min	50,3	52,8	50,7	44,6	40,0	32,0	25,2	40	51
		Med	57,7	59,5	56,9	51,6	49,6	43,3	34,5	47	58
		Max	64,3	66,1	62,4	57,5	55,7	51,3	46,8	53	64
	Lwi	Min	32,5	32,3	25,2	16,4	5,5	n.m.	n.m.	16	27
		Mid	39,9	39,0	31,4	23,3	15,1	n.m.	n.m.	23	34
		Max	46,5	45,6	36,8	29,2	21,2	11,4	n.m.	29	40
	Lwm	Min	47,4	49,7	44,9	40,5	37,8	29,2	22,2	36	47
		Mid	54,8	56,4	51,0	47,5	47,4	40,5	31,5	43	54
		Max	61,4	63,0	56,5	53,4	53,5	48,5	43,8	50	61
	Lwa	Min	47,0	49,8	49,4	42,5	35,9	28,8	22,3	38	49
		Mid	54,4	56,5	55,6	49,4	45,5	40,1	31,6	45	56
		Max	61,0	63,1	61,0	55,3	51,6	48,1	43,9	51	62

The sound pressure level is measured 1 metre from the external surface of the wall mounted in view unit. For the built-in unit it is possible a sound pressure reduction of 2 dB or higher. The determination of the sound pressure levels has been made with respect to the UNI-EN-ISO 3744 certification.  
n.m. = not measurable

# Sound levels

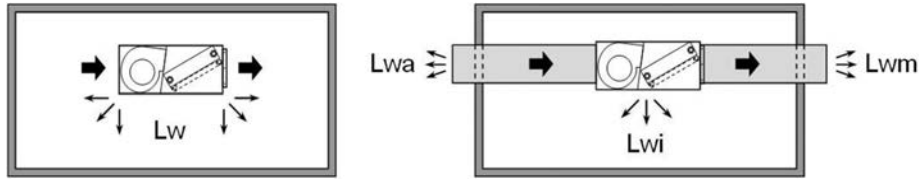

- Lw** Total sound power emitted by the unit
- Lwi** Radiated sound power, emitted by the lateral surfaces of the unit
- Lwm** Sound power emitted by the air supply side of the unit
- Lwa** Sound power emitted by the air intake side of the unit

## Size 011.0 (CC2-CC4)

Static pressure	Sound power	Fan speed	Sound power level (dB)							Sound pressure level	Sound power level
			Octave band (Hz)								
			125	250	500	1000	2000	4000	8000		
0 Pa	Lw	Min	42,5	44,5	43,9	34,6	31,4	26,7	21,2	32	43
		Mid	49,0	50,7	50,3	44,0	40,3	33,1	23,9	39	50
		Max	51,6	53,9	53,1	47,2	44,3	37,7	29,0	43	54
	Lwi	Min	24,7	23,3	18,4	6,3	n.m.	n.m.	n.m.	8	19
		Mid	31,1	30,2	24,8	15,7	5,9	n.m.	n.m.	15	26
		Max	33,8	33,4	27,6	18,9	9,8	n.m.	n.m.	18	29
	Lwm	Min	39,5	40,6	38,0	30,3	29,1	23,8	18,0	28	39
		Mid	45,9	47,5	44,4	39,7	38,0	30,2	20,8	35	46
		Max	48,6	50,7	47,1	43,0	42,0	34,8	25,8	38	49
	Lwa	Min	39,3	40,9	42,7	32,5	27,5	23,6	18,2	30	41
		Mid	45,8	47,8	49,0	41,9	36,4	29,9	21,0	37	48
		Max	48,4	51,0	51,8	45,1	40,4	34,5	26,1	41	52
25 Pa	Lw	Min	43,5	44,8	45,0	35,6	32,4	27,8	22,2	33	44
		Mid	50,0	51,7	51,3	45,0	41,3	34,1	25,0	40	51
		Max	52,6	54,9	54,1	48,2	45,3	38,7	30,0	44	55
	Lwi	Min	25,7	24,3	19,4	7,3	n.m.	n.m.	n.m.	9	20
		Mid	32,2	31,2	25,8	16,7	6,9	n.m.	n.m.	16	27
		Max	34,8	34,4	28,6	20,0	10,9	n.m.	n.m.	19	30
	Lwm	Min	40,5	41,6	39,0	31,4	30,1	24,9	19,0	29	40
		Mid	47,0	48,5	45,4	40,7	39,0	31,2	21,8	36	47
		Max	49,6	51,7	48,2	44,0	43,0	35,8	26,9	39	50
	Lwa	Min	40,4	42,0	43,7	33,6	28,5	24,6	19,3	31	42
		Mid	46,8	48,9	50,1	42,9	37,4	31,0	22,1	38	49
		Max	49,5	52,1	52,8	46,2	41,4	35,6	27,1	42	53
50 Pa	Lw	Min	44,6	45,9	46,0	36,6	33,4	28,8	23,2	34	45
		Mid	51,0	52,8	52,4	46,0	42,3	35,1	26,0	42	53
		Max	53,7	56,0	55,1	49,3	46,3	39,7	31,0	45	56
	Lwi	Min	26,7	25,3	20,5	8,4	n.m.	n.m.	n.m.	10	21
		Mid	33,2	32,2	26,8	17,7	7,9	n.m.	n.m.	17	28
		Max	35,8	35,5	29,6	21,0	11,9	n.m.	n.m.	20	31
	Lwm	Min	41,6	42,6	40,0	32,4	31,1	25,9	20,0	30	41
		Mid	48,0	49,5	46,4	41,8	40,1	32,2	22,8	37	48
		Max	50,7	52,7	49,2	45,0	44,0	36,8	27,9	40	51
	Lwa	Min	41,4	43,0	44,7	34,6	29,5	25,7	20,3	32	43
		Mid	47,8	49,9	51,1	44,0	38,5	32,0	23,1	40	51
		Max	50,5	53,1	53,8	47,2	42,5	36,6	28,2	43	54
75 Pa	Lw	Min	45,6	46,9	47,0	37,7	34,4	29,8	24,2	35	46
		Med	52,0	53,8	53,4	47,0	43,4	36,1	27,0	43	54
		Max	54,7	57,0	56,2	50,3	47,4	40,7	32,1	46	57
	Lwi	Min	27,8	26,4	21,5	9,4	n.m.	n.m.	n.m.	11	22
		Mid	34,2	33,3	27,9	18,8	8,9	n.m.	n.m.	18	29
		Max	36,9	36,5	30,6	22,0	12,9	n.m.	n.m.	21	32
	Lwm	Min	42,6	43,7	41,1	33,4	32,2	26,9	21,1	31	42
		Mid	49,0	50,5	47,4	42,8	41,1	33,2	23,9	38	49
		Max	51,7	53,8	50,2	46,0	45,1	37,8	28,9	41	52
	Lwa	Min	42,4	44,0	45,7	35,6	30,6	26,7	21,3	33	44
		Mid	48,9	50,9	52,1	45,0	39,5	33,0	24,1	41	52
		Max	51,5	54,1	54,9	48,2	43,5	37,6	29,2	44	55

The sound pressure level is measured 1 metre from the external surface of the wall mounted in view unit. For the built-in unit it is possible a sound pressure reduction of 2 dB or higher. The determination of the sound pressure levels has been made with respect to the UNI-EN-ISO 3744 certification.

n.m. = not measurable

## Sound levels

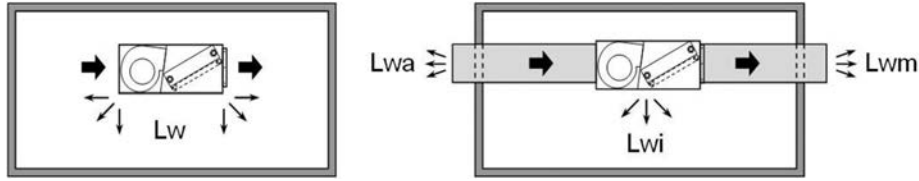

- Lw** Total sound power emitted by the unit
- Lwi** Radiated sound power, emitted by the lateral surfaces of the unit
- Lwm** Sound power emitted by the air supply side of the unit
- Lwa** Sound power emitted by the air intake side of the unit

### Size 015.0 (CC2-CC4)

Static pressure	Sound power	Fan speed	Sound power level (dB)							Sound pressure level	Sound power level
			Octave band (Hz)								
			125	250	500	1000	2000	4000	8000	dB(A)	dB(A)
0 Pa	Lw	Min	43,2	45,2	44,6	35,3	32,1	27,4	21,9	33	44
		Med	50,8	51,8	51,0	44,7	41,0	33,8	24,6	40	51
		Max	53,9	54,2	53,8	47,9	45,0	38,4	29,7	43	54
	Lwi	Min	25,4	24,7	19,1	7,0	n.m.	n.m.	n.m.	9	20
		Med	33,0	31,2	25,5	16,4	6,6	n.m.	n.m.	16	27
		Max	36,1	33,7	28,3	19,6	10,5	n.m.	n.m.	18	29
	Lwm	Min	40,2	41,9	38,7	31,0	29,8	24,5	18,7	28	39
		Med	47,8	48,5	45,1	40,4	38,7	30,9	21,5	36	47
		Max	50,9	51,0	47,8	43,7	42,7	35,5	26,5	39	50
	Lwa	Min	40,0	42,3	43,4	33,2	28,2	24,3	18,9	31	42
		Med	47,6	48,9	49,7	42,6	37,1	30,6	21,7	38	49
		Max	50,8	51,4	52,5	45,8	41,1	35,2	26,8	41	52
25 Pa	Lw	Min	44,2	46,2	45,7	36,3	33,1	28,5	22,9	34	45
		Med	51,8	52,8	52,0	45,7	42,0	34,8	25,7	41	52
		Max	54,9	55,3	54,8	48,9	46,0	39,4	30,7	44	55
	Lwi	Min	26,4	25,7	20,1	8,00	n.m.	n.m.	n.m.	10	21
		Med	34,0	32,3	26,5	17,4	7,6	n.m.	n.m.	17	28
		Max	37,1	34,7	29,3	20,7	11,6	n.m.	n.m.	19	30
	Lwm	Min	41,2	43,0	39,7	32,1	30,8	25,6	19,7	30	41
		Med	48,8	49,6	46,1	41,4	39,7	31,9	22,5	37	48
		Max	51,9	52,0	48,9	44,7	43,7	36,5	27,6	40	51
	Lwa	Min	41,1	43,3	44,4	34,3	29,2	25,4	20,0	32	43
		Med	48,6	49,9	50,8	43,6	38,1	31,7	22,8	39	50
		Max	51,8	52,4	53,5	46,9	42,1	36,3	27,8	42	53
50 Pa	Lw	Min	45,3	47,2	46,7	37,3	34,1	29,5	23,9	35	46
		Med	52,8	53,8	53,1	46,7	43,0	35,8	26,7	42	53
		Max	56,0	56,3	55,8	50,0	47,0	40,4	31,7	45	56
	Lwi	Min	27,4	26,7	21,2	9,1	n.m.	n.m.	n.m.	11	22
		Med	35,0	33,3	27,5	18,4	8,6	n.m.	n.m.	18	29
		Max	38,2	35,8	30,3	21,7	12,6	n.m.	n.m.	20	31
	Lwm	Min	42,3	44,0	40,7	33,1	31,8	26,6	20,7	31	42
		Med	49,8	50,6	47,1	42,5	40,8	32,9	23,5	38	49
		Max	53,0	53,1	49,9	45,7	44,7	37,5	28,6	41	52
	Lwa	Min	42,1	44,4	45,4	35,3	30,2	26,4	21,0	33	44
		Med	49,7	50,9	51,8	44,7	39,2	32,7	23,8	40	51
		Max	52,8	53,4	54,5	47,9	43,2	37,3	28,9	43	54
75 Pa	Lw	Min	46,3	48,3	47,7	38,4	35,1	30,5	24,9	36	47
		Med	53,9	54,8	54,1	47,7	44,1	36,8	27,7	43	54
		Max	57,0	57,3	56,9	51,0	48,1	41,4	32,8	46	57
	Lwi	Min	28,5	27,7	22,2	10,1	n.m.	n.m.	n.m.	12	23
		Med	36,0	34,3	28,6	19,5	9,6	n.m.	n.m.	19	30
		Max	39,2	36,8	31,3	22,7	13,6	n.m.	n.m.	21	32
	Lwm	Min	43,3	45,0	41,8	34,1	32,9	27,6	21,8	32	43
		Med	50,9	51,6	48,1	43,5	41,8	33,9	24,6	39	50
		Max	54,0	54,1	50,9	46,7	45,8	38,5	29,6	42	53
	Lwa	Min	43,1	45,4	46,4	36,3	31,3	27,4	22,0	34	45
		Med	50,7	52,0	52,8	45,7	40,2	33,7	24,8	41	52
		Max	53,8	54,4	55,6	48,9	44,2	38,3	29,9	44	55

The sound pressure level is measured 1 metre from the external surface of the wall mounted in view unit. For the built-in unit it is possible a sound pressure reduction of 2 dB or higher. The determination of the sound pressure levels has been made with respect to the UNI-EN-ISO 3744 certification.  
n.m. = not measurable

# Sound levels

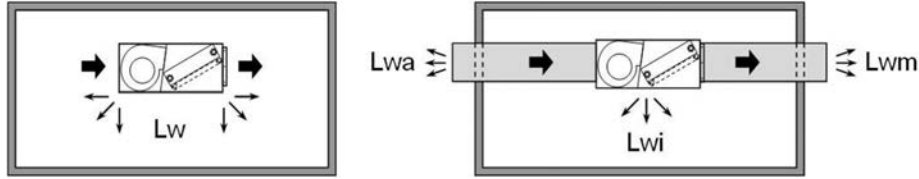

- Lw** Total sound power emitted by the unit
- Lwi** Radiated sound power, emitted by the lateral surfaces of the unit
- Lwm** Sound power emitted by the air supply side of the unit
- Lwa** Sound power emitted by the air intake side of the unit

## Size 017.0 (CC2-CC4)

Static pressure	Sound power	Fan speed	Sound power level (dB)							Sound pressure level	Sound power level
			Octave band (Hz)								
			125	250	500	1000	2000	4000	8000		
0 Pa	Lw	Min	46,8	51,5	50,6	44,3	41,5	32,8	21,2	40	51
		Mid	52,6	56,8	56,5	51,9	49,8	44,8	35,3	47	58
		Max	56,5	60,0	58,3	54,1	53,3	48,5	41,2	49	60
	Lwi	Min	28,9	31,0	25,0	16,1	7,1	n.m.	n.m.	15	26
		Mid	34,7	36,3	31,0	23,6	15,4	n.m.	n.m.	21	32
		Max	38,7	39,5	32,8	25,9	18,8	8,5	n.m.	23	34
	Lwm	Min	43,8	48,3	44,6	40,1	39,2	29,9	18,0	36	47
		Mid	49,6	53,6	50,5	47,6	47,5	41,9	32,2	43	54
		Max	53,5	56,7	52,4	49,9	51,0	45,6	38,1	46	57
	Lwa	Min	43,6	48,7	49,3	42,3	37,6	29,7	18,3	38	49
		Mid	49,4	54,0	55,2	49,8	45,9	41,6	32,4	45	56
		Max	53,3	57,1	57,0	52,1	49,4	45,4	38,4	47	58
30 Pa	Lw	Min	47,8	52,6	51,6	45,4	42,5	33,8	22,2	41	52
		Mid	53,6	57,9	57,5	52,9	50,8	45,8	36,3	48	59
		Max	57,5	61,0	59,4	55,2	54,3	49,5	42,3	50	61
	Lwi	Min	30,0	32,0	26,1	17,1	8,1	n.m.	n.m.	16	27
		Mid	35,8	37,3	32,0	24,6	16,4	5,8	n.m.	22	33
		Max	39,7	40,5	33,8	26,9	19,9	9,6	n.m.	25	36
	Lwm	Min	44,8	49,3	45,6	41,1	40,2	30,9	19,0	37	48
		Mid	50,6	54,6	51,6	48,7	48,5	42,9	33,2	44	55
		Max	54,5	57,8	53,4	50,9	52,0	46,6	39,1	47	58
	Lwa	Min	44,6	49,7	50,3	43,3	38,7	30,7	19,3	39	50
		Mid	50,4	55,0	56,2	50,9	47,0	42,7	33,5	46	57
		Max	54,3	58,1	58,1	53,1	50,4	46,4	39,4	48	59
60 Pa	Lw	Min	48,8	53,6	52,6	46,4	43,6	34,9	23,2	42	53
		Mid	54,6	58,9	58,5	53,9	51,9	46,8	37,4	49	60
		Max	58,5	62,0	60,4	56,2	55,3	50,5	43,3	52	63
	Lwi	Min	31,0	33,1	27,1	18,1	9,1	n.m.	n.m.	17	28
		Mid	36,8	38,4	33,0	25,7	17,4	6,9	n.m.	23	34
		Max	40,7	41,5	34,9	27,9	20,9	10,6	n.m.	26	37
	Lwm	Min	45,8	50,3	46,7	42,2	41,3	31,9	20,1	38	49
		Mid	51,6	55,6	52,6	49,7	49,6	43,9	34,2	45	56
		Max	55,5	58,8	54,4	51,9	53,0	47,6	40,2	48	59
	Lwa	Min	45,6	50,7	51,3	44,3	39,7	31,7	20,3	40	51
		Mid	51,5	56,0	57,2	51,9	48,0	43,7	34,5	47	58
		Max	55,4	59,2	59,1	54,1	51,5	47,4	40,4	49	60
90 Pa	Lw	Min	49,8	54,6	53,6	47,4	44,6	35,9	24,3	43	54
		Med	55,6	59,9	59,6	55,0	52,9	47,8	38,4	50	61
		Max	59,5	63,1	61,4	57,2	56,4	51,6	44,3	53	64
	Lwi	Min	32,0	34,1	28,1	19,2	10,1	n.m.	n.m.	18	29
		Mid	37,8	39,4	34,0	26,7	18,5	7,9	n.m.	24	35
		Max	41,7	42,5	35,9	28,9	21,9	11,6	n.m.	27	38
	Lwm	Min	46,8	51,4	47,7	43,2	42,3	33,0	21,1	39	50
		Mid	52,6	56,7	53,6	50,7	50,6	44,9	35,3	46	57
		Max	56,5	59,8	55,5	53,0	54,1	48,7	41,2	49	60
	Lwa	Min	46,7	51,7	52,3	45,4	40,7	32,8	21,4	41	52
		Mid	52,5	57,0	58,3	52,9	49,0	44,7	35,5	48	59
		Max	56,4	60,2	60,1	55,2	52,5	48,4	41,4	50	61

The sound pressure level is measured 1 metre from the external surface of the wall mounted in view unit. For the built-in unit it is possible a sound pressure reduction of 2 dB or higher. The determination of the sound pressure levels has been made with respect to the UNI-EN-ISO 3744 certification.  
n.m. = not measurable

# Sound levels

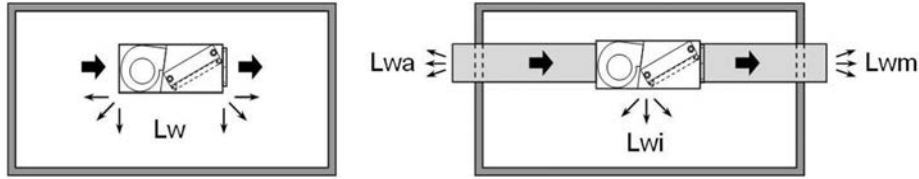

- Lw Total sound power emitted by the unit
- Lwi Radiated sound power, emitted by the lateral surfaces of the unit
- Lwm Sound power emitted by the air supply side of the unit
- Lwa Sound power emitted by the air intake side of the unit

## Size 021.0 (CC2-CC4)

Static pressure	Sound power	Fan speed	Sound power level (dB)							Sound pressure level	Sound power level
			Octave band (Hz)								
			125	250	500	1000	2000	4000	8000		
0 Pa	Lw	Min	49,5	51,7	51,3	45,0	42,2	33,5	21,9	41	52
		Mid	53,9	57,3	57,2	52,6	50,5	45,5	36,0	47	58
		Max	57,6	60,9	60,7	56,2	54,0	50,8	41,9	51	62
	Lwi	Min	31,7	31,2	25,7	16,8	7,8	n.m.	n.m.	16	27
		Mid	36,0	36,8	31,7	24,3	16,1	5,5	n.m.	22	33
		Max	39,8	40,4	35,1	28,0	19,5	10,9	n.m.	25	36
	Lwm	Min	46,5	48,5	45,3	40,8	39,9	30,6	18,7	36	47
		Mid	50,9	54,1	51,2	48,3	48,2	42,6	32,9	43	54
		Max	54,6	57,7	54,7	52,0	51,7	47,9	38,8	47	58
	Lwa	Min	46,3	48,8	50,0	43,0	38,3	30,4	19,0	39	50
		Mid	50,7	54,4	55,9	50,5	46,6	42,3	33,1	45	56
		Max	54,4	58,0	59,4	54,2	50,1	47,7	39,1	49	60
30 Pa	Lw	Min	50,5	52,7	52,3	46,1	43,2	34,5	22,9	42	53
		Mid	54,9	58,3	58,2	53,6	51,5	46,5	37,0	49	60
		Max	58,6	61,9	61,7	57,3	55,0	51,8	43,0	52	63
	Lwi	Min	32,7	32,2	26,8	17,8	8,8	n.m.	n.m.	17	28
		Mid	37,1	37,8	32,7	25,3	17,1	6,5	n.m.	23	34
		Max	40,8	41,4	36,2	29,0	20,6	11,9	n.m.	26	37
	Lwm	Min	47,5	49,5	46,3	41,8	40,9	31,6	19,7	37	48
		Mid	51,9	55,1	52,3	49,4	49,2	43,6	33,9	45	56
		Max	55,6	58,7	55,7	53,0	52,7	48,9	39,8	48	59
	Lwa	Min	47,4	49,9	51,0	44,0	39,4	31,4	20,0	40	51
		Mid	51,7	55,4	56,9	51,6	47,7	43,4	34,2	46	57
		Max	55,5	59,1	60,4	55,2	51,1	48,7	40,1	50	61
60 Pa	Lw	Min	51,6	53,8	53,3	47,1	44,3	35,6	23,9	43	54
		Mid	55,9	59,3	59,2	54,6	52,6	47,5	38,1	50	61
		Max	59,7	63,0	62,7	58,3	56,0	52,9	44,0	53	64
	Lwi	Min	33,7	33,2	27,8	18,8	9,8	n.m.	n.m.	18	29
		Mid	38,1	38,8	33,7	26,4	18,1	7,6	n.m.	24	35
		Max	41,8	42,4	37,2	30,0	21,6	12,9	n.m.	27	38
	Lwm	Min	48,6	50,5	47,4	42,9	42,0	32,6	20,8	38	49
		Mid	52,9	56,1	53,3	50,4	50,3	44,6	34,9	46	57
		Max	56,7	59,7	56,8	54,0	53,7	50,0	40,9	49	60
	Lwa	Min	48,4	50,9	52,0	45,0	40,4	32,4	21,0	41	52
		Mid	52,8	56,5	57,9	52,6	48,7	44,4	35,2	47	58
		Max	56,5	60,1	61,4	56,2	52,2	49,7	41,1	51	62
90 Pa	Lw	Min	52,6	54,8	54,3	48,1	45,3	36,6	25,0	44	55
		Med	56,9	60,4	60,3	55,7	53,6	48,5	39,1	51	62
		Max	60,7	64,0	63,7	59,3	57,1	53,9	45,0	54	65
	Lwi	Min	34,8	34,3	28,8	19,9	10,8	n.m.	n.m.	19	30
		Mid	39,1	39,8	34,7	27,4	19,2	8,6	n.m.	25	36
		Max	42,9	43,5	38,2	31,0	22,6	13,9	n.m.	28	39
	Lwm	Min	49,6	51,5	48,4	43,9	43,0	33,7	21,8	39	50
		Mid	53,9	57,1	54,3	51,4	51,3	45,6	36,0	47	58
		Max	57,7	60,8	57,8	55,1	54,8	51,0	41,9	50	61
	Lwa	Min	49,4	51,9	53,0	46,1	41,4	33,5	22,1	42	53
		Mid	53,8	57,5	59,0	53,6	49,7	45,4	36,2	48	59
		Max	57,5	61,1	62,5	57,2	53,2	50,8	42,1	52	63

The sound pressure level is measured 1 metre from the external surface of the wall mounted in view unit. For the built-in unit it is possible a sound pressure reduction of 2 dB or higher. The determination of the sound pressure levels has been made with respect to the UNI-EN-ISO 3744 certification.  
 n.m. = not measurable

# Sound levels

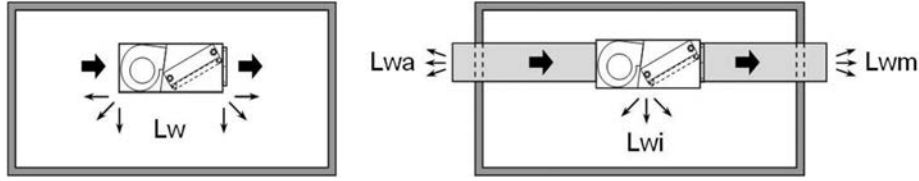

- Lw** Total sound power emitted by the unit
- Lwi** Radiated sound power, emitted by the lateral surfaces of the unit
- Lwm** Sound power emitted by the air supply side of the unit
- Lwa** Sound power emitted by the air intake side of the unit

## Size 025.0 (CC2-CC4)

Static pressure	Sound power	Fan speed	Sound power level (dB)							Sound pressure level dB(A)	Sound power level dB(A)
			Octave band (Hz)								
			125	250	500	1000	2000	4000	8000		
0 Pa	Lw	Min	49,5	55,5	54,9	50,3	48,3	39,8	30,4	45	56
		Mid	57,4	60,5	60,0	58,9	55,2	49,9	41,4	52	63
		Max	60,8	64,7	62,5	59,1	57,7	54,1	46,5	54	65
	Lwi	Min	31,7	35,0	29,4	22,1	13,9	n.m.	n.m.	19	30
		Mid	39,6	40,0	34,4	30,6	20,8	9,9	n.m.	25	36
		Max	43,0	44,1	37,0	30,8	23,3	14,2	n.m.	28	39
	Lwm	Min	46,4	52,1	48,8	45,9	45,9	36,8	27,2	41	52
		Mid	54,2	57,2	53,9	54,5	52,8	46,9	38,2	48	59
		Max	57,7	61,3	56,4	54,7	55,3	51,1	43,3	50	61
	Lwa	Min	46,5	52,7	53,7	48,4	44,6	36,8	27,6	43	54
		Mid	54,3	57,8	58,7	57,0	51,5	46,9	38,6	50	61
		Max	57,8	61,9	61,2	57,1	54,1	51,1	43,7	52	63
30 Pa	Lw	Min	50,6	56,6	56,1	51,5	49,5	41,0	31,6	46	57
		Mid	58,5	61,7	61,1	60,1	56,3	51,0	42,6	53	64
		Max	62,0	65,8	63,7	60,2	58,9	55,3	47,7	55	66
	Lwi	Min	32,8	36,1	30,5	23,2	15,0	n.m.	n.m.	20	31
		Mid	40,7	41,2	35,6	31,8	21,9	11,1	n.m.	26	37
		Max	44,1	45,3	38,1	32,0	24,5	15,3	n.m.	29	40
	Lwm	Min	47,5	53,3	50,0	47,1	47,0	38,0	28,3	42	53
		Mid	55,4	58,3	55,0	55,7	53,9	48,0	39,4	49	60
		Max	58,8	62,5	57,6	55,8	56,5	52,3	44,5	51	62
	Lwa	Min	47,6	53,9	54,8	49,5	45,8	38,0	28,8	44	55
		Mid	55,5	58,9	59,9	58,1	52,7	48,0	39,8	51	62
		Max	58,9	63,1	62,4	58,3	55,2	52,3	44,9	53	64
60 Pa	Lw	Min	51,8	57,8	57,2	52,6	50,6	42,1	32,7	47	58
		Mid	59,7	62,8	62,3	61,2	57,5	52,2	43,8	54	65
		Max	63,1	67,0	64,8	61,4	60,1	56,4	48,8	56	67
	Lwi	Min	34,0	37,3	31,7	24,4	16,2	n.m.	n.m.	22	33
		Mid	41,9	42,3	36,7	33,0	23,1	12,2	n.m.	28	39
		Max	45,3	46,5	39,3	33,1	25,6	16,5	n.m.	30	41
	Lwm	Min	48,7	54,4	51,1	48,2	48,2	39,1	29,5	43	54
		Mid	56,6	59,5	56,2	56,8	55,1	49,2	40,5	50	61
		Max	60,0	63,6	58,7	57,0	57,6	53,4	45,6	53	64
	Lwa	Min	48,8	55,0	56,0	50,7	46,9	39,1	29,9	45	56
		Mid	56,6	60,1	61,0	59,3	53,8	49,2	41,0	52	63
		Max	60,1	64,2	63,6	59,4	56,4	53,4	46,0	54	65
90 Pa	Lw	Min	53,0	58,9	58,4	53,8	51,8	43,3	33,9	49	60
		Med	60,8	64,0	63,4	62,4	58,7	53,3	44,9	55	66
		Max	64,3	68,1	66,0	62,6	61,2	57,6	50,0	58	69
	Lwi	Min	35,1	38,4	32,8	25,5	17,3	n.m.	n.m.	23	34
		Mid	43,0	43,5	37,9	34,1	24,2	13,4	n.m.	29	40
		Max	46,4	47,6	40,4	34,3	26,8	17,6	n.m.	31	42
	Lwm	Min	49,8	55,6	52,3	49,4	49,3	40,3	30,7	44	55
		Mid	57,7	60,6	57,3	58,0	56,2	50,3	41,7	51	62
		Max	61,1	64,8	59,9	58,2	58,8	54,6	46,8	54	65
	Lwa	Min	49,9	56,2	57,1	51,8	48,1	40,3	31,1	46	57
		Mid	57,8	61,2	62,2	60,4	55,0	50,3	42,1	53	64
		Max	61,2	65,4	64,7	60,6	57,5	54,6	47,2	55	66

The sound pressure level is measured 1 metre from the external surface of the wall mounted in view unit. For the built-in unit it is possible a sound pressure reduction of 2 dB or higher. The determination of the sound pressure levels has been made with respect to the UNI-EN-ISO 3744 certification.  
n.m. = not measurable

## Sound levels

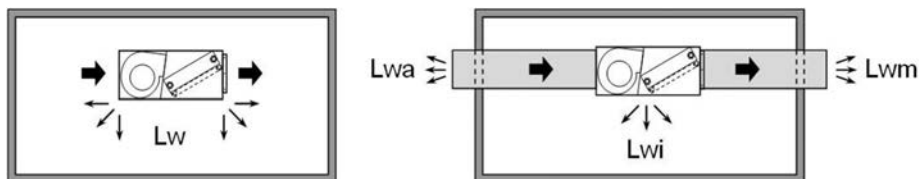

- Lw Total sound power emitted by the unit
- Lwi Radiated sound power, emitted by the lateral surfaces of the unit
- Lwm Sound power emitted by the air supply side of the unit
- Lwa Sound power emitted by the air intake side of the unit

### Size 031.0 (CC2-CC4)

Static pressure	Sound power	Fan speed	Sound power level (dB)							Sound pressure level	Sound power level
			Octave band (Hz)								
			125	250	500	1000	2000	4000	8000		
0 Pa	Lw	Min	50,2	56,2	55,6	51,0	49,0	40,5	31,1	46	57
		Mid	58,1	61,2	61,6	57,9	55,9	50,6	42,1	52	63
		Max	61,5	65,4	63,2	59,8	58,4	54,8	47,2	55	66
	Lwi	Min	32,4	35,7	30,1	22,8	14,6	n.m.	n.m.	20	31
		Mid	40,3	40,7	36,0	29,6	21,5	10,6	n.m.	26	37
		Max	43,7	44,8	37,7	31,5	24,0	14,9	n.m.	29	40
	Lwm	Min	47,1	52,8	49,5	46,6	46,6	37,5	27,9	42	53
		Mid	54,9	57,9	55,5	53,5	53,5	47,6	38,9	48	59
		Max	58,4	62,0	57,1	55,4	56,0	51,8	44,0	51	62
	Lwa	Min	47,2	53,4	54,4	49,1	45,3	37,5	28,3	44	55
		Mid	55,0	58,5	60,3	55,9	52,2	47,6	39,3	50	61
		Max	58,5	62,6	61,9	57,8	54,8	51,8	44,4	52	63
30 Pa	Lw	Min	51,3	57,3	56,8	52,2	50,2	41,7	32,3	47	58
		Mid	59,2	62,4	62,7	59,1	57,0	51,7	43,3	54	65
		Max	62,7	66,5	64,4	60,9	59,6	56,0	48,4	56	67
	Lwi	Min	33,5	36,8	31,2	23,9	15,7	n.m.	n.m.	21	32
		Mid	41,4	41,9	37,2	30,8	22,6	11,8	n.m.	27	38
		Max	44,8	46,0	38,8	32,7	25,2	16,0	n.m.	30	41
	Lwm	Min	48,2	54,0	50,7	47,8	47,7	38,7	29,0	43	54
		Mid	56,1	59,0	56,6	54,7	54,6	48,7	40,1	49	60
		Max	59,5	63,2	58,3	56,5	57,2	53,0	45,2	52	63
	Lwa	Min	48,3	54,6	55,5	50,2	46,5	38,7	29,5	45	56
		Mid	56,2	59,6	61,5	57,1	53,4	48,7	40,5	51	62
		Max	59,6	63,8	63,1	59,0	55,9	53,0	45,6	54	65
60 Pa	Lw	Min	52,5	58,5	57,9	53,3	51,3	42,8	33,4	48	59
		Mid	60,4	63,5	63,9	60,2	58,2	52,9	44,5	55	66
		Max	63,8	67,7	65,5	62,1	60,8	57,1	49,5	57	68
	Lwi	Min	34,7	38,0	32,4	25,1	16,9	n.m.	n.m.	22	33
		Mid	42,6	43,0	38,3	31,9	23,8	12,9	n.m.	28	39
		Max	46,0	47,2	40,0	33,8	26,3	17,2	n.m.	31	42
	Lwm	Min	49,4	55,1	51,8	48,9	48,9	39,8	30,2	44	55
		Mid	57,3	60,2	57,8	55,8	55,8	49,9	41,2	51	62
		Max	60,7	64,3	59,4	57,7	58,3	54,1	46,3	53	64
	Lwa	Min	49,5	55,7	56,7	51,4	47,6	39,8	30,6	46	57
		Mid	57,3	60,8	62,6	58,3	54,5	49,9	41,7	52	63
		Max	60,8	64,9	64,3	60,1	57,1	54,1	46,7	55	66
90 Pa	Lw	Min	53,7	59,6	59,1	54,5	52,5	44,0	34,6	49	60
		Med	61,5	64,7	65,0	61,4	59,4	54,0	45,6	56	67
		Max	65,0	68,8	66,7	63,3	61,9	58,3	50,7	58	69
	Lwi	Min	35,8	39,1	33,5	26,2	18,0	n.m.	n.m.	23	34
		Mid	43,7	44,2	39,5	33,1	24,9	14,1	n.m.	29	40
		Max	47,1	48,3	41,1	35,0	27,5	18,3	5,4	32	43
	Lwm	Min	50,5	56,3	53,0	50,1	50,0	41,0	31,4	45	56
		Mid	58,4	61,3	59,0	57,0	56,9	51,0	42,4	52	63
		Max	61,8	65,5	60,6	58,9	59,5	55,3	47,5	54	65
	Lwa	Min	50,6	56,9	57,8	52,5	48,8	41,0	31,8	47	58
		Mid	58,5	61,9	63,8	59,4	55,7	51,0	42,8	54	65
		Max	61,9	66,1	65,4	61,3	58,2	55,3	47,9	56	67

The sound pressure level is measured 1 metre from the external surface of the wall mounted in view unit. For the built-in unit it is possible a sound pressure reduction of 2 dB or higher. The determination of the sound pressure levels has been made with respect to the UNI-EN-ISO 3744 certification.  
n.m. = not measurable

# Sound levels

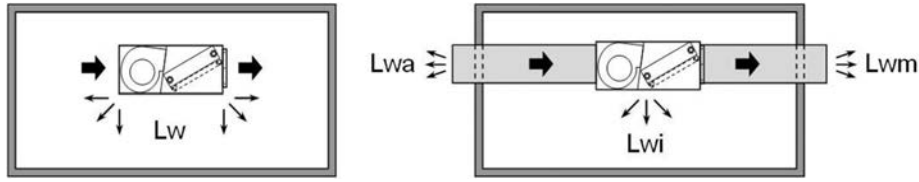

- Lw** Total sound power emitted by the unit
- Lwi** Radiated sound power, emitted by the lateral surfaces of the unit
- Lwm** Sound power emitted by the air supply side of the unit
- Lwa** Sound power emitted by the air intake side of the unit

## Size 041.0 (CC2-CC4)

Static pressure	Sound power	Fan speed	Sound power level (dB)							Sound pressure level	Sound power level
			Octave band (Hz)								
			125	250	500	1000	2000	4000	8000		
0 Pa	Lw	Min	52,6	59,9	59,7	57,8	54,7	48,5	39,2	51	62
		Mid	55,2	62,7	61,8	60,5	56,8	51,5	42,8	54	65
		Max	58,0	65,5	64,8	63,9	60,3	55,8	47,7	57	68
	Lwi	Min	34,8	39,4	34,1	29,5	20,2	8,5	n.m.	25	36
		Mid	37,4	42,1	36,3	32,2	22,3	11,6	n.m.	27	38
		Max	40,2	45,0	39,3	35,6	25,8	15,9	n.m.	30	41
	Lwm	Min	49,5	56,6	53,6	53,4	52,2	45,5	36,0	47	58
		Mid	52,1	59,3	55,7	56,1	54,3	48,5	39,6	50	61
		Max	54,9	62,2	58,8	59,5	57,8	52,8	44,5	53	64
	Lwa	Min	49,5	57,2	58,4	55,8	51,0	45,5	36,4	49	60
		Mid	52,2	59,9	60,6	58,5	53,1	48,5	40,0	51	62
		Max	55,0	62,8	63,6	61,9	56,6	52,8	44,9	55	66
30 Pa	Lw	Min	53,7	61,1	60,8	59,0	55,8	49,7	40,3	52	63
		Mid	56,4	63,8	63,0	61,6	57,9	52,7	44,0	55	66
		Max	59,2	66,7	66,0	65,1	61,4	57,0	48,9	58	69
	Lwi	Min	35,9	40,6	35,3	30,7	21,4	9,7	n.m.	26	37
		Mid	38,5	43,3	37,4	33,4	23,5	12,7	n.m.	28	39
		Max	41,4	46,2	40,5	36,8	27,0	17,0	n.m.	31	42
	Lwm	Min	50,6	57,7	54,7	54,6	53,4	46,6	37,1	48	59
		Mid	53,2	60,5	56,9	57,2	55,5	49,7	40,7	51	62
		Max	56,0	63,3	59,9	60,7	59,0	54,0	45,7	54	65
	Lwa	Min	50,7	58,3	59,6	57,0	52,1	46,6	37,5	50	61
		Mid	53,3	61,1	61,7	59,7	54,2	49,7	41,2	53	64
		Max	56,1	63,9	64,7	63,1	57,7	54,0	46,1	56	67
60 Pa	Lw	Min	54,9	62,2	62,0	60,1	57,0	50,8	41,5	54	65
		Mid	57,5	65,0	64,1	62,8	59,1	53,9	45,1	56	67
		Max	60,3	67,8	67,2	66,2	62,6	58,1	50,1	59	70
	Lwi	Min	37,1	41,7	36,4	31,9	22,5	10,9	n.m.	27	38
		Mid	39,7	44,5	38,6	34,5	24,6	13,9	n.m.	29	40
		Max	42,5	47,3	41,6	37,9	28,1	18,2	n.m.	32	43
	Lwm	Min	51,8	58,9	55,9	55,7	54,5	47,8	38,3	50	61
		Mid	54,4	61,6	58,1	58,4	56,7	50,8	41,9	52	63
		Max	57,2	64,5	61,1	61,8	60,2	55,1	46,8	55	66
	Lwa	Min	51,8	59,5	60,7	58,2	53,3	47,8	38,7	51	62
		Mid	54,5	62,2	62,9	60,8	55,4	50,8	42,3	54	65
		Max	57,3	65,1	65,9	64,2	58,9	55,1	47,2	57	68
90 Pa	Lw	Min	56,0	63,4	63,1	61,3	58,1	52,0	42,6	55	66
		Med	58,7	66,1	65,3	63,9	60,2	55,0	46,3	57	68
		Max	61,5	69,0	68,3	67,4	63,7	59,3	51,2	60	71
	Lwi	Min	38,2	42,9	37,6	33,0	23,7	12,0	n.m.	28	39
		Mid	40,9	45,6	39,8	35,7	25,8	15,1	n.m.	30	41
		Max	43,7	48,5	42,8	39,1	29,3	19,3	5,9	34	45
	Lwm	Min	52,9	60,0	57,0	56,9	55,7	48,9	39,4	51	62
		Mid	55,5	62,8	59,2	59,5	57,8	52,0	43,1	53	64
		Max	58,3	65,6	62,2	63,0	61,3	56,3	48,0	57	68
	Lwa	Min	53,0	60,6	61,9	59,3	54,4	49,0	39,8	52	63
		Mid	55,6	63,4	64,0	62,0	56,5	52,0	43,5	55	66
		Max	58,4	66,2	67,1	65,4	60,0	56,3	48,4	58	69

The sound pressure level is measured 1 metre from the external surface of the wall mounted in view unit. For the built-in unit it is possible a sound pressure reduction of 2 dB or higher. The determination of the sound pressure levels has been made with respect to the UNI-EN-ISO 3744 certification.  
n.m. = not measurable



# Sound levels

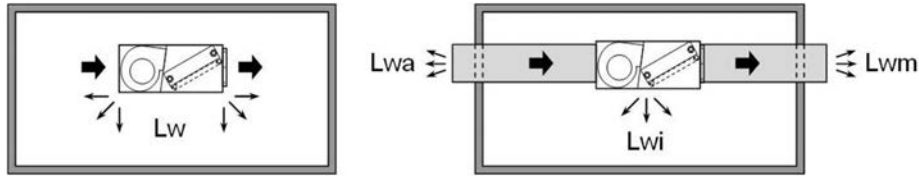

- Lw** Total sound power emitted by the unit
- Lwi** Radiated sound power, emitted by the lateral surfaces of the unit
- Lwm** Sound power emitted by the air supply side of the unit
- Lwa** Sound power emitted by the air intake side of the unit

## Size 051.0 (CC2-CC4)

Static pressure	Sound power	Fan speed	Sound power level (dB)							Sound pressure level dB(A)	Sound Power Level dB(A)
			Octave band (Hz)								
			125	250	500	1000	2000	4000	8000		
0 Pa	Lw	Min	53,3	60,9	60,5	57,9	55,4	49,2	39,9	52	63
		Mid	55,9	63,4	62,6	60,9	57,5	52,2	43,5	54	65
		Max	58,7	66,5	65,5	64,3	59,0	56,5	48,4	57	68
	Lwi	Min	35,5	40,4	34,9	29,6	20,9	9,2	n.m.	25	36
		Mid	38,1	42,8	37,1	32,6	23,0	12,3	n.m.	28	39
		Max	40,9	46,0	40,0	36,0	24,6	16,6	n.m.	31	42
	Lwm	Min	50,2	57,6	54,4	53,5	52,9	46,2	36,7	48	59
		Mid	52,8	60,0	56,6	56,5	55,0	49,2	40,3	50	61
		Max	55,6	63,2	59,5	59,9	56,6	53,5	45,2	53	64
	Lwa	Min	50,2	58,2	59,2	55,9	51,7	46,2	37,1	50	61
		Mid	52,9	60,6	61,4	58,9	53,8	49,2	40,7	52	63
		Max	55,7	63,8	64,3	62,3	53,3	53,5	45,6	55	66
30 Pa	Lw	Min	54,4	62,1	61,6	59,1	56,5	50,4	41,0	53	64
		Mid	57,1	64,5	63,8	62,1	58,6	53,4	44,7	55	66
		Max	59,9	67,7	66,7	65,4	60,1	57,7	49,6	58	69
	Lwi	Min	36,6	41,6	36,1	30,8	22,1	10,4	n.m.	26	37
		Mid	39,2	44,0	38,3	33,8	24,2	13,4	n.m.	29	40
		Max	42,1	47,2	41,2	37,2	25,7	17,7	n.m.	32	43
	Lwm	Min	51,3	58,7	55,6	54,7	54,1	47,3	37,8	49	60
		Mid	53,9	61,2	57,7	57,7	56,2	50,4	41,4	51	62
		Max	56,7	64,3	60,6	61,0	57,7	54,7	46,4	54	65
	Lwa	Min	51,4	59,3	60,4	57,1	52,8	47,3	38,2	51	62
		Mid	54,0	61,8	62,5	60,1	54,9	50,4	41,9	53	64
		Max	56,8	64,9	65,4	63,5	54,7	54,7	46,8	56	67
60 Pa	Lw	Min	55,6	63,2	62,8	60,2	57,7	51,5	42,2	54	65
		Mid	58,2	65,7	64,9	63,2	59,8	54,6	45,8	57	68
		Max	61,0	68,8	67,9	66,6	61,3	58,8	50,8	60	71
	Lwi	Min	37,8	42,7	37,3	31,9	23,2	11,6	n.m.	28	39
		Mid	40,4	45,2	39,4	34,9	25,3	14,6	n.m.	30	41
		Max	43,2	48,3	42,3	38,3	26,9	18,9	5,5	33	44
	Lwm	Min	52,5	59,9	56,7	55,8	55,2	48,5	39,0	50	61
		Mid	55,1	62,3	58,9	58,8	57,4	51,5	42,6	53	64
		Max	57,9	65,5	61,8	62,2	58,9	55,8	47,5	55	66
	Lwa	Min	52,5	60,5	61,5	58,2	54,0	48,5	39,4	52	63
		Mid	55,2	62,9	63,7	61,2	56,1	51,5	43,0	54	65
		Max	58,0	66,1	66,6	64,6	57,6	55,8	47,9	57	68
90 Pa	Lw	Min	56,7	64,4	63,9	61,4	58,8	52,7	43,3	55	66
		Med	59,4	66,8	66,1	64,4	60,9	55,7	47,0	58	69
		Max	62,2	70,0	69,0	67,8	62,5	60,0	51,9	61	72
	Lwi	Min	38,9	43,9	38,4	33,1	24,4	12,7	n.m.	29	40
		Mid	41,6	46,3	40,6	36,1	26,5	15,8	n.m.	31	42
		Max	44,4	49,5	43,5	39,5	28,0	20,0	6,6	34	45
	Lwm	Min	53,6	61,0	57,9	57,0	56,4	49,6	40,1	51	62
		Mid	56,2	63,5	60,0	60,0	58,5	52,7	43,8	54	65
		Max	59,0	66,6	62,9	63,4	60,0	57,0	48,7	57	68
	Lwa	Min	53,7	61,6	62,7	59,4	55,1	49,7	40,5	53	64
		Mid	56,3	64,1	64,8	62,4	57,2	52,7	44,2	56	67
		Max	59,1	67,2	67,8	65,8	58,8	57,0	49,1	59	70

The sound pressure level is measured 1 metre from the external surface of the wall mounted in view unit. For the built-in unit it is possible a sound pressure reduction of 2 dB or higher. The determination of the sound pressure levels has been made with respect to the UNI-EN-ISO 3744 certification.  
n.m. = not measurable

# Aeraulic performance graphics - 2 pipe system (CC2)

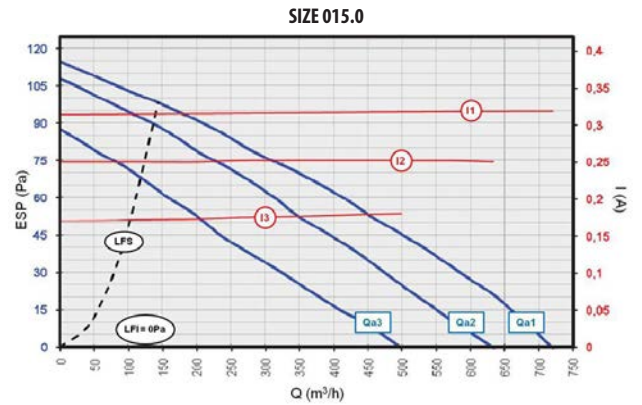
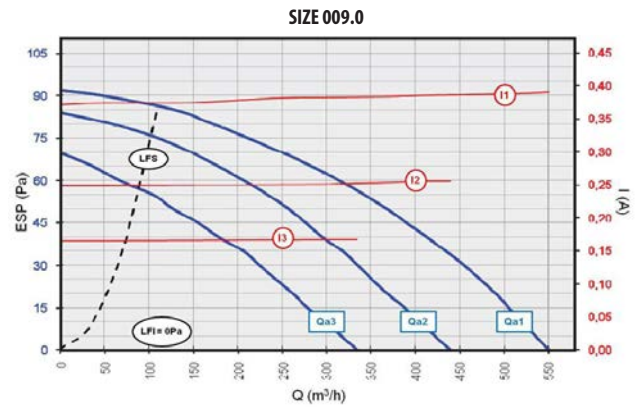
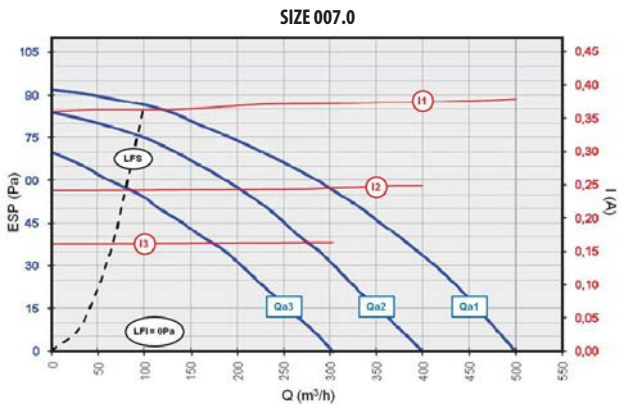
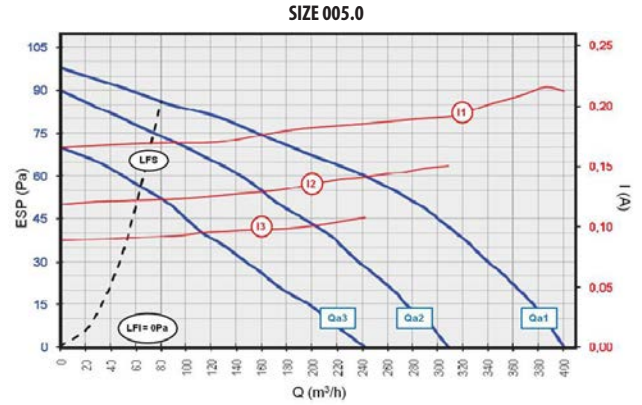
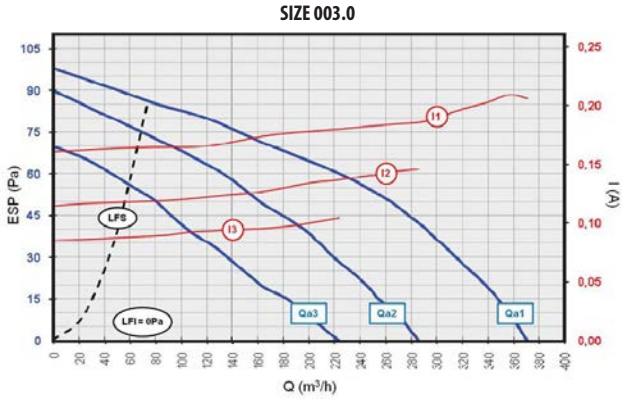

Q = Air flow [m<sup>3</sup>/h]  
 ESP = External static pressure (Pa)  
 I (A) = Full load current (A) with 230V-1Ph-50Hz power supply  
 LFS = Higher operating limit  
 LFI = Lower operating limit

Qa1 = Air flow / Static pressure curve at MAX speed  
 Qa2 = Air flow / Static pressure curve at MID speed  
 Qa3 = Air flow / Static pressure curve at MIN speed  
 I1 = Air flow / Full load current curve at MAX speed  
 I2 = Air flow / Full load current curve at MID speed  
 I3 = Air flow / Full load current curve at MIN speed

# Aeraulic performance graphics - 2 pipe system (CC2)

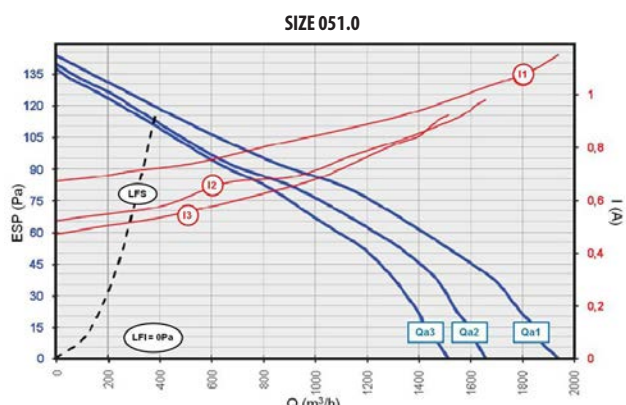
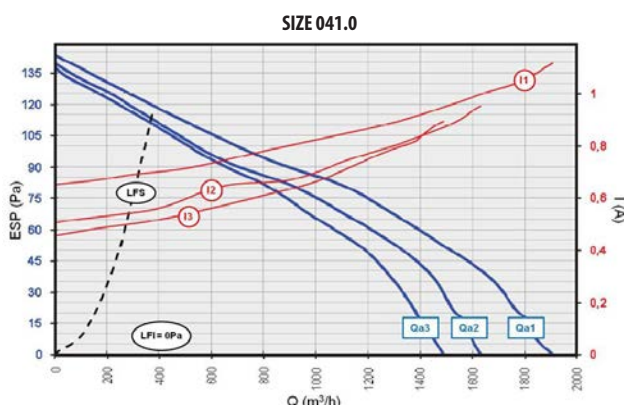
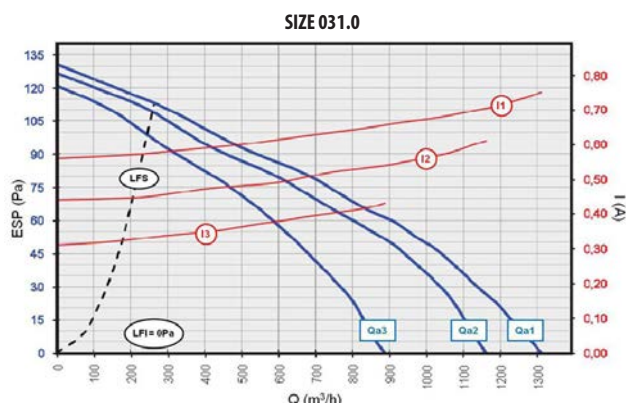
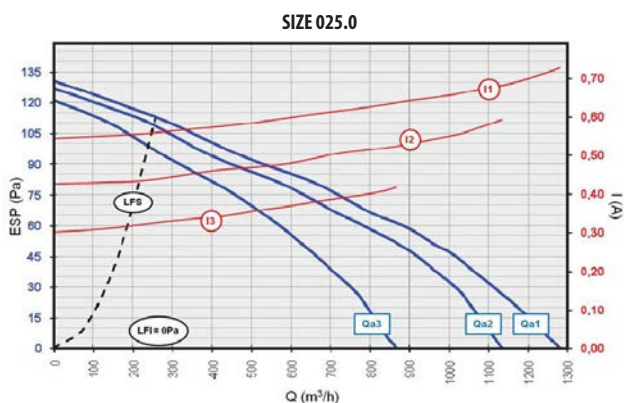
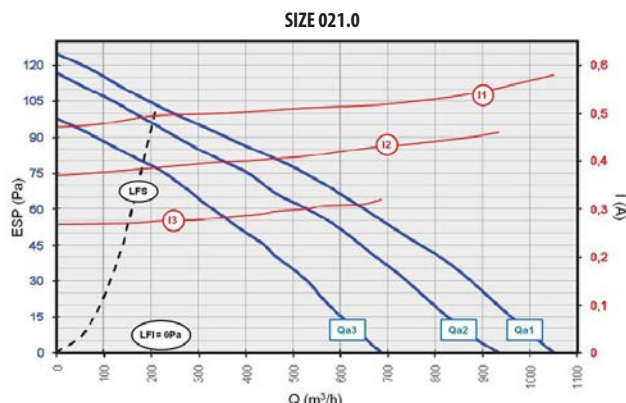
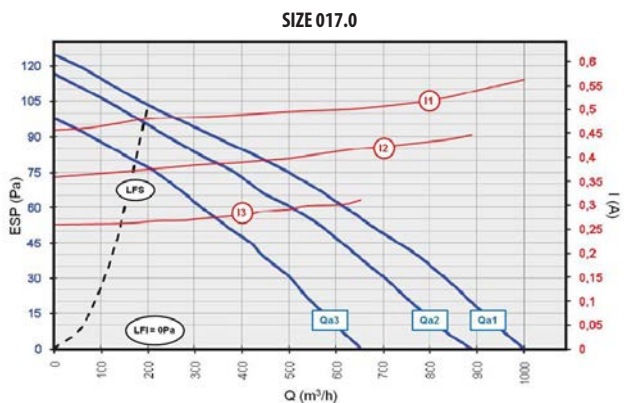

Q = Air flow [m<sup>3</sup>/h]  
 ESP = External static pressure (Pa)  
 I (A) = Full load current (A) with 230V-1Ph-50Hz power supply  
 LFS = Higher operating limit  
 LFI = Lower operating limit

Qa1 = Air flow / Static pressure curve at MAX speed  
 Qa2 = Air flow / Static pressure curve at MID speed  
 Qa3 = Air flow / Static pressure curve at MIN speed  
 I1 = Air flow / Full load current curve at MAX speed  
 I2 = Air flow / Full load current curve at MID speed  
 I3 = Air flow / Full load current curve at MIN speed

# Aeraulic performance graphics - 4 pipe system (CC4)

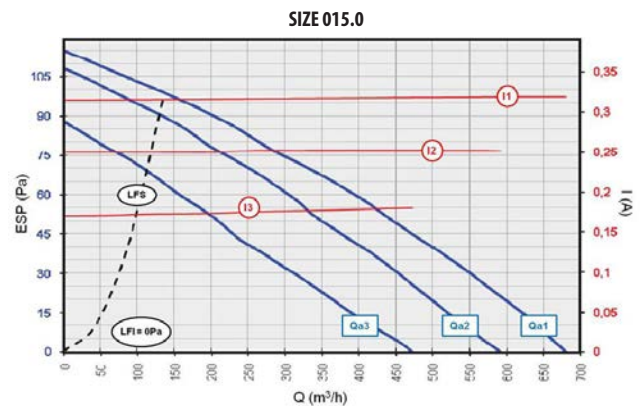
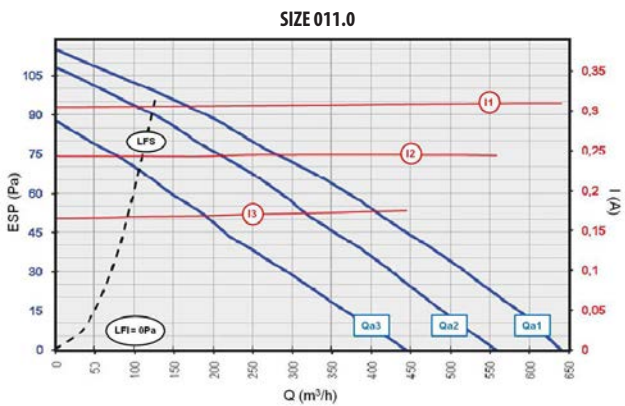
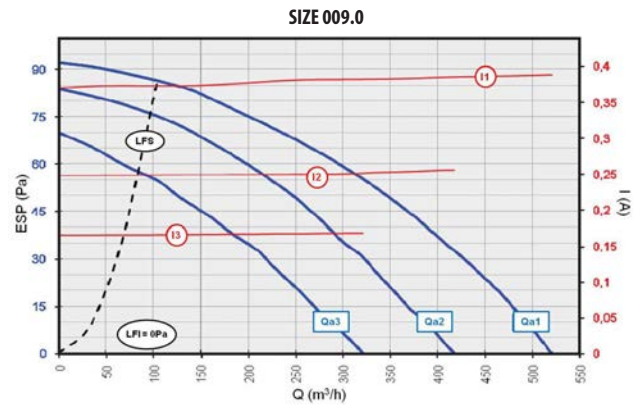
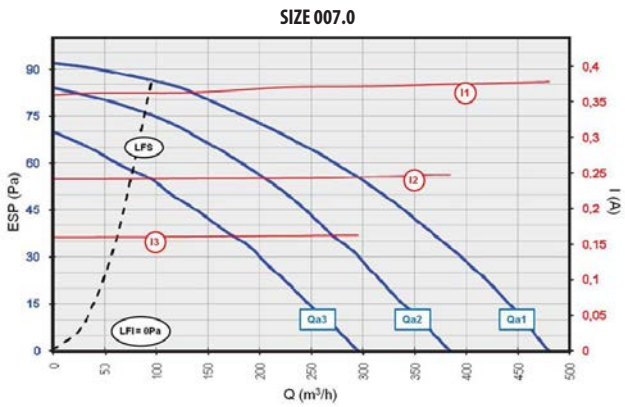
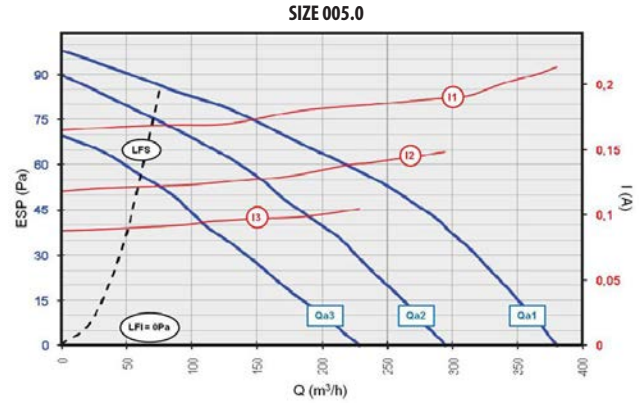
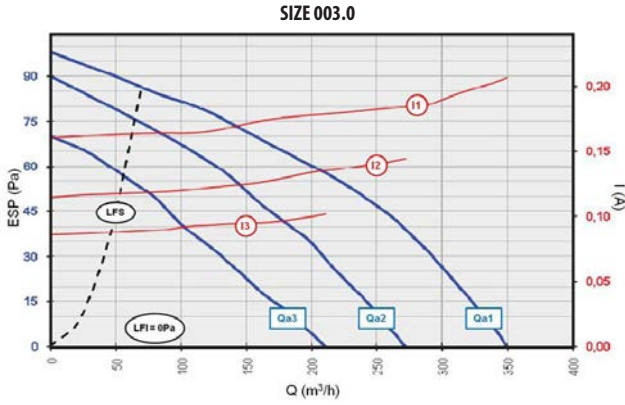

Q = Air flow [m<sup>3</sup>/h]  
 ESP = External static pressure (Pa)  
 I (A) = Full load current (A) with 230V-1Ph-50Hz power supply  
 LFS = Higher operating limit  
 LFI = Lower operating limit

Qa1 = Air flow / Static pressure curve at MAX speed  
 Qa2 = Air flow / Static pressure curve at MID speed  
 Qa3 = Air flow / Static pressure curve at MIN speed  
 I1 = Air flow / Full load current curve at MAX speed  
 I2 = Air flow / Full load current curve at MID speed  
 I3 = Air flow / Full load current curve at MIN speed

# Aeraulic performance graphics - 4 pipe system (CC4)

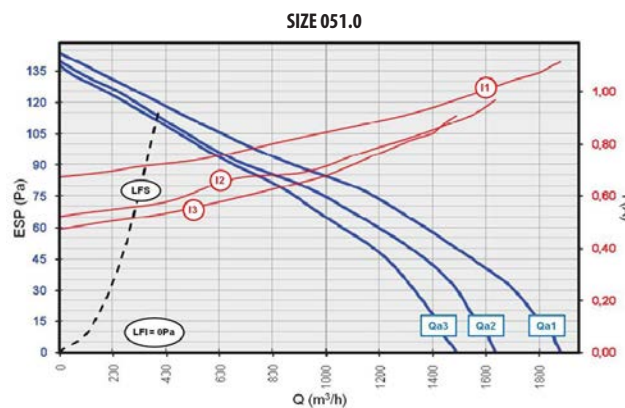
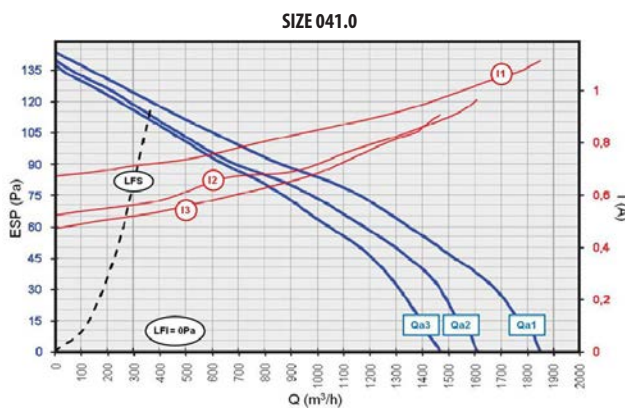
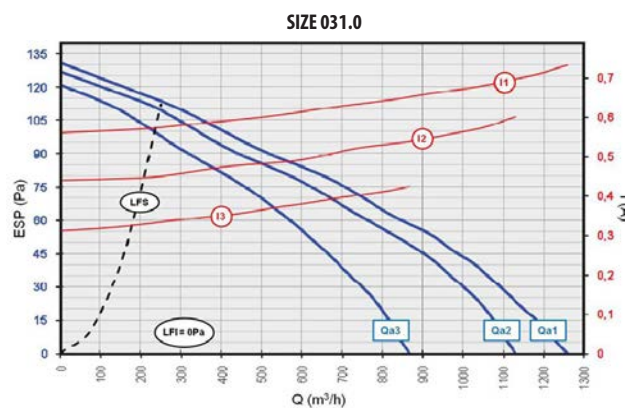
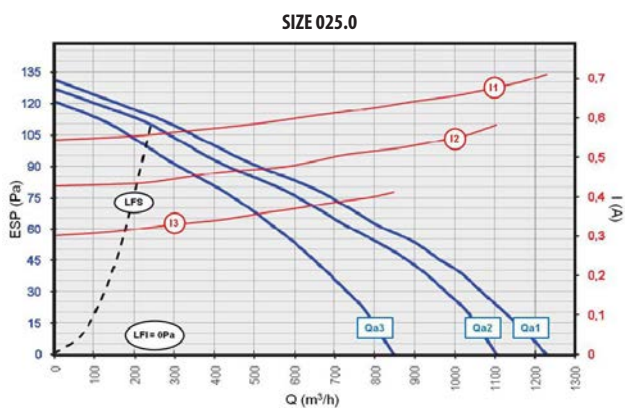
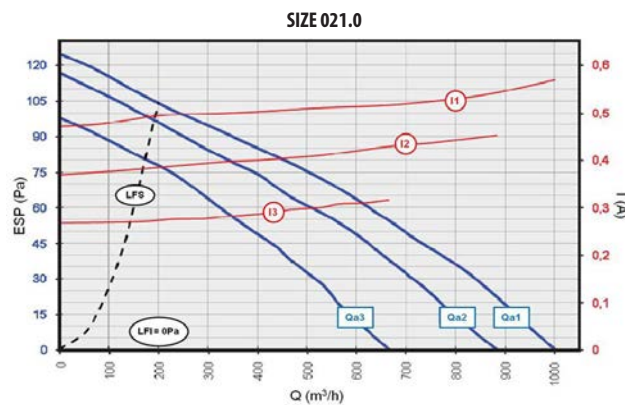
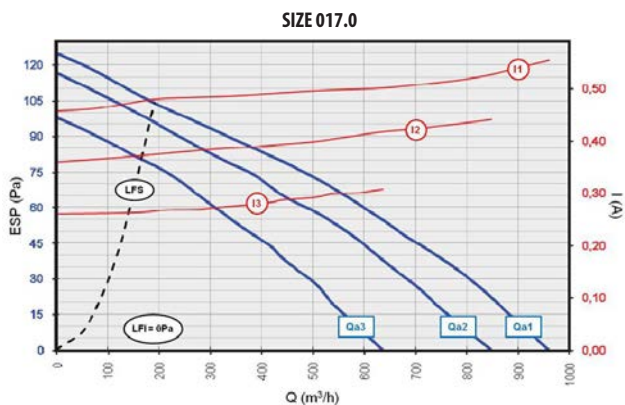

Q = Air flow [m<sup>3</sup>/h]  
 ESP = External static pressure (Pa)  
 I (A) = Full load current (A) with 230V-1Ph-50Hz power supply  
 LFS = Higher operating limit  
 LFI = Lower operating limit

Qa1 = Air flow / Static pressure curve at MAX speed  
 Qa2 = Air flow / Static pressure curve at MID speed  
 Qa3 = Air flow / Static pressure curve at MIN speed  
 I1 = Air flow / Full load current curve at MAX speed  
 I2 = Air flow / Full load current curve at MID speed  
 I3 = Air flow / Full load current curve at MIN speed

# Performance - 2 pipe system (CC2)

## Cooling - AC fans (standard)

Size	Ta (°C) D.B. / W.B.	Inlet exchanger water temperature (°)									
		5		7		10		13		15	
		Total power [kW <sub>f</sub> ]	Sensible power [kW <sub>s</sub> ]	Total power [kW <sub>f</sub> ]	Sensible power [kW <sub>s</sub> ]	Total power [kW <sub>f</sub> ]	Sensible power [kW <sub>s</sub> ]	Total power [kW <sub>f</sub> ]	Sensible power [kW <sub>s</sub> ]	Total power [kW <sub>f</sub> ]	Sensible power [kW <sub>s</sub> ]
003.0	22 / 16	1,34	1,07	1,03	0,92	0,70	0,70	0,48	0,48	0,33	0,33
	24 / 17	1,50	1,22	1,18	1,07	0,85	0,85	0,63	0,63	0,48	0,48
	26 / 18	1,66	1,36	1,34	1,22	1,00	1,00	0,77	0,77	0,63	0,63
	27 / 19	1,82	1,44	1,50	1,29	1,07	1,07	0,85	0,85	0,70	0,70
	28 / 20	1,97	1,51	1,66	1,36	1,18	1,14	0,92	0,92	0,77	0,77
	30 / 22	2,29	1,66	1,97	1,51	1,50	1,29	1,07	1,07	0,92	0,92
005.0	22 / 16	1,79	1,34	1,37	1,16	0,88	0,88	0,60	0,60	0,42	0,42
	24 / 17	2,00	1,53	1,58	1,34	1,06	1,06	0,79	0,79	0,60	0,60
	26 / 18	2,21	1,71	1,79	1,53	1,25	1,25	0,97	0,97	0,79	0,79
	27 / 19	2,42	1,81	2,00	1,62	1,37	1,34	1,06	1,06	0,88	0,88
	28 / 20	2,63	1,90	2,21	1,71	1,58	1,43	1,16	1,16	0,97	0,97
	30 / 22	3,05	2,08	2,63	1,90	2,00	1,62	1,37	1,34	1,16	1,16
007.0	22 / 16	2,26	1,72	1,73	1,48	1,12	1,12	0,77	0,77	0,53	0,53
	24 / 17	2,53	1,95	2,00	1,72	1,36	1,36	1,01	1,01	0,77	0,77
	26 / 18	2,80	2,19	2,26	1,95	1,60	1,60	1,24	1,24	1,01	1,01
	27 / 19	3,06	2,31	2,53	2,07	1,73	1,72	1,36	1,36	1,12	1,12
	28 / 20	3,33	2,42	2,80	2,19	2,00	1,83	1,48	1,48	1,24	1,24
	30 / 22	3,86	2,66	3,33	2,42	2,53	2,07	1,73	1,72	1,48	1,48
009.0	22 / 16	2,70	1,91	2,07	1,65	1,25	1,25	0,86	0,86	0,59	0,59
	24 / 17	3,02	2,18	2,38	1,91	1,52	1,52	1,12	1,12	0,86	0,86
	26 / 18	3,34	2,44	2,70	2,18	1,78	1,78	1,39	1,39	1,12	1,12
	27 / 19	3,66	2,57	3,02	2,31	2,07	1,91	1,52	1,52	1,25	1,25
	28 / 20	3,97	2,71	3,34	2,44	2,38	2,05	1,65	1,65	1,39	1,39
	30 / 22	4,61	2,97	3,97	2,71	3,02	2,31	2,07	1,91	1,65	1,65
011.0	22 / 16	3,36	2,38	2,57	2,05	1,56	1,56	1,07	1,07	0,74	0,74
	24 / 17	3,75	2,71	2,96	2,38	1,89	1,89	1,39	1,39	1,07	1,07
	26 / 18	4,14	3,03	3,36	2,71	2,21	2,21	1,72	1,72	1,39	1,39
	27 / 19	4,54	3,20	3,75	2,87	2,57	2,38	1,89	1,89	1,56	1,56
	28 / 20	4,93	3,36	4,14	3,03	2,96	2,54	2,05	2,05	1,72	1,72
	30 / 22	5,72	3,69	4,93	3,36	3,75	2,87	2,57	2,38	2,05	2,05
015.0	22 / 16	3,80	2,68	2,91	2,31	1,75	1,75	1,20	1,20	0,83	0,83
	24 / 17	4,25	3,05	3,36	2,68	2,12	2,12	1,57	1,57	1,20	1,20
	26 / 18	4,70	3,41	3,80	3,05	2,49	2,49	1,94	1,94	1,57	1,57
	27 / 19	5,14	3,60	4,25	3,23	2,91	2,68	2,12	2,12	1,75	1,75
	28 / 20	5,59	3,78	4,70	3,41	3,36	2,86	2,31	2,31	1,94	1,94
	30 / 22	6,49	4,15	5,59	3,78	4,25	3,23	2,91	2,68	2,31	2,31

Technical data referred to the following conditions:

Air flow at maximum speed (ESP = 0Pa)

Water temperature differential = 5°C

Ta = Air intake temperature

WB = wet bulb

DB = dry bulb

kW<sub>f</sub> = Cooling capacity in kW

kW<sub>s</sub> = Sensible cooling capacity (kW)

# Performance - 2 pipe system (CC2)

## Cooling - AC fans (standard)

Size	Ta (°C) D.B. / W.B.	Inlet exchanger water temperature (°)									
		5		7		10		13		15	
		Total power [kW <sub>F</sub> ]	Sensible power [kW <sub>S</sub> ]	Total power [kW <sub>F</sub> ]	Sensible power [kW <sub>S</sub> ]	Total power [kW <sub>F</sub> ]	Sensible power [kW <sub>S</sub> ]	Total power [kW <sub>F</sub> ]	Sensible power [kW <sub>S</sub> ]	Total power [kW <sub>F</sub> ]	Sensible power [kW <sub>S</sub> ]
017.0	22 / 16	4,94	3,59	3,78	3,09	2,35	2,35	1,61	1,61	1,11	1,11
	24 / 17	5,52	4,08	4,36	3,59	2,85	2,85	2,10	2,10	1,61	1,61
	26 / 18	6,10	4,58	4,94	4,08	3,34	3,34	2,60	2,60	2,10	2,10
	27 / 19	6,68	4,82	5,52	4,33	3,78	3,59	2,85	2,85	2,35	2,35
	28 / 20	7,26	5,07	6,10	4,58	4,36	3,84	3,09	3,09	2,60	2,60
	30 / 22	8,43	5,57	7,26	5,07	5,52	4,33	3,78	3,59	3,09	3,09
021.0	22 / 16	5,74	3,98	4,39	3,43	2,61	2,61	1,78	1,78	1,23	1,23
	24 / 17	6,42	4,53	5,07	3,98	3,15	3,15	2,33	2,33	1,78	1,78
	26 / 18	7,10	5,07	5,74	4,53	3,72	3,70	2,88	2,88	2,33	2,33
	27 / 19	7,77	5,35	6,42	4,80	4,39	3,98	3,15	3,15	2,61	2,61
	28 / 20	8,45	5,62	7,10	5,07	5,07	4,25	3,43	3,43	2,88	2,88
	30 / 22	9,80	6,17	8,45	5,62	6,42	4,80	4,39	3,98	3,43	3,43
025.0	22 / 16	6,74	4,70	5,15	4,05	3,08	3,08	2,11	2,11	1,46	1,46
	24 / 17	7,53	5,35	5,94	4,70	3,73	3,73	2,75	2,75	2,11	2,11
	26 / 18	8,32	5,99	6,74	5,35	4,37	4,37	3,40	3,40	2,75	2,75
	27 / 19	9,12	6,32	7,53	5,67	5,15	4,70	3,73	3,73	3,08	3,08
	28 / 20	9,91	6,64	8,32	5,99	5,94	5,02	4,05	4,05	3,40	3,40
	30 / 22	11,49	7,29	9,91	6,64	7,53	5,67	5,15	4,70	4,05	4,05
031.0	22 / 16	8,07	5,49	6,17	4,73	3,59	3,59	2,46	2,46	1,70	1,70
	24 / 17	9,02	6,24	7,12	5,49	4,35	4,35	3,22	3,22	2,46	2,46
	26 / 18	9,97	7,00	8,07	6,24	5,22	5,11	3,97	3,97	3,22	3,22
	27 / 19	10,92	7,38	9,02	6,62	6,17	5,49	4,35	4,35	3,59	3,59
	28 / 20	11,87	7,75	9,97	7,00	7,12	5,86	4,73	4,73	3,97	3,97
	30 / 22	13,77	8,51	11,87	7,75	9,02	6,62	6,17	5,49	4,73	4,73
041.0	22 / 16	8,59	6,33	6,57	5,46	4,15	4,15	2,84	2,84	1,96	1,96
	24 / 17	9,60	7,20	7,58	6,33	5,02	5,02	3,71	3,71	2,84	2,84
	26 / 18	10,61	8,08	8,59	7,20	5,89	5,89	4,58	4,58	3,71	3,71
	27 / 19	11,62	8,51	9,60	7,64	6,57	6,33	5,02	5,02	4,15	4,15
	28 / 20	12,63	8,95	10,61	8,08	7,58	6,77	5,46	5,46	4,58	4,58
	30 / 22	14,65	9,82	12,63	8,95	9,60	7,64	6,57	6,33	5,46	5,46
051.0	22 / 16	9,58	6,93	7,33	5,97	4,54	4,54	3,11	3,11	2,15	2,15
	24 / 17	10,71	7,88	8,46	6,93	5,49	5,49	4,06	4,06	3,11	3,11
	26 / 18	11,84	8,84	9,58	7,88	6,45	6,45	5,02	5,02	4,06	4,06
	27 / 19	12,96	9,32	10,71	8,36	7,33	6,93	5,49	5,49	4,54	4,54
	28 / 20	14,09	9,79	11,84	8,84	8,46	7,40	5,97	5,97	5,02	5,02
	30 / 22	16,35	10,75	14,09	9,79	10,71	8,36	7,33	6,93	5,97	5,97

Technical data referred to the following conditions:

Air flow at maximum speed (ESP = 0Pa)

Water temperature differential = 5°C

Ta = Air intake temperature

WB = wet bulb

DB = dry bulb

kW<sub>F</sub> = Cooling capacity in kW

kW<sub>S</sub> = Sensible cooling capacity (kW)

## Performance - 2 pipe system (CC2)

### Heating - AC fans (standard)

Size	Ta (°C)	Inlet exchanger water temperature (°)							
		35	40	45	50	55	60	70	80
		Total power [kW <sub>T</sub> ]	Total power [kW <sub>T</sub> ]	Total power [kW <sub>T</sub> ]	Total power [kW <sub>T</sub> ]	Total power [kW <sub>T</sub> ]	Total power [kW <sub>T</sub> ]	Total power [kW <sub>T</sub> ]	Total power [kW <sub>T</sub> ]
003.0	10	1,66	2,08	2,49	2,91	3,32	3,74	4,57	5,40
	15	1,25	1,66	2,08	2,41	2,83	3,24	4,07	4,90
	18	1,00	1,41	1,83	2,24	2,66	3,08	3,91	4,74
	20	0,83	1,25	1,66	2,08	2,49	2,91	3,74	4,57
	22	0,66	1,08	1,50	1,91	2,33	2,74	3,57	4,40
	25	0,42	0,83	1,25	1,66	2,08	2,49	3,32	4,16
005.0	10	2,18	2,73	3,27	3,82	4,36	4,91	6,00	7,09
	15	1,64	2,18	2,73	3,16	3,71	4,26	5,35	6,44
	18	1,31	1,85	2,40	2,95	3,49	4,04	5,13	6,22
	20	1,09	1,64	2,18	2,73	3,27	3,82	4,91	6,00
	22	0,87	1,42	1,96	2,51	3,06	3,60	4,69	5,78
	25	0,55	1,09	1,64	2,18	2,73	3,27	4,36	5,46
007.0	10	2,66	3,32	3,99	4,65	5,32	5,98	7,31	8,64
	15	1,99	2,66	3,32	3,85	4,52	5,18	6,51	7,84
	18	1,59	2,26	2,92	3,59	4,25	4,92	6,25	7,57
	20	1,33	1,99	2,66	3,32	3,99	4,65	5,98	7,31
	22	1,06	1,73	2,39	3,06	3,72	4,39	5,71	7,04
	25	0,66	1,33	1,99	2,66	3,32	3,99	5,32	6,64
009.0	10	2,98	3,73	4,47	5,22	5,96	6,71	8,20	9,69
	15	2,24	2,98	3,73	4,32	5,07	5,82	7,31	8,80
	18	1,79	2,53	3,28	4,03	4,77	5,52	7,01	8,50
	20	1,49	2,24	2,98	3,73	4,47	5,22	6,71	8,20
	22	1,19	1,94	2,68	3,43	4,18	4,92	6,41	7,90
	25	0,75	1,49	2,24	2,98	3,73	4,47	5,96	7,46
011.0	10	3,63	4,53	5,44	6,35	7,25	8,16	9,97	11,79
	15	2,72	3,63	4,53	5,26	6,17	7,07	8,89	10,70
	18	2,18	3,08	3,99	4,90	5,80	6,71	8,52	10,34
	20	1,81	2,72	3,63	4,53	5,44	6,35	8,16	9,97
	22	1,45	2,36	3,26	4,17	5,08	5,98	7,80	9,61
	25	0,91	1,81	2,72	3,63	4,53	5,44	7,25	9,07
015.0	10	4,20	5,24	6,29	7,34	8,39	9,44	11,54	13,64
	15	3,15	4,20	5,24	6,08	7,13	8,18	10,28	12,38
	18	2,52	3,57	4,62	5,66	6,71	7,76	9,86	11,96
	20	2,10	3,15	4,20	5,24	6,29	7,34	9,44	11,54
	22	1,68	2,73	3,78	4,82	5,87	6,92	9,02	11,12
	25	1,05	2,10	3,15	4,20	5,24	6,29	8,39	10,49

Technical data referred to the following conditions:

Air flow at maximum speed (ESP = 0Pa)

Water temperature differential = 10°C

Ta = Air intake temperature

kW<sub>T</sub> = Thermal power in kW



# Performance - 2 pipe system (CC2)

## Heating - AC fans (standard)

Size	Ta (°C)	Inlet exchanger water temperature (°)							
		35	40	45	50	55	60	70	80
		Total power [kW <sub>T</sub> ]	Total power [kW <sub>T</sub> ]	Total power [kW <sub>T</sub> ]	Total power [kW <sub>T</sub> ]	Total power [kW <sub>T</sub> ]	Total power [kW <sub>T</sub> ]	Total power [kW <sub>T</sub> ]	Total power [kW <sub>T</sub> ]
017.0	10	5,33	6,67	8,00	9,33	10,67	12,00	14,67	17,33
	15	4,00	5,33	6,67	8,00	9,33	10,67	13,33	16,00
	18	3,20	4,53	5,87	7,20	8,53	9,87	12,53	15,20
	20	2,67	4,00	5,33	6,67	8,00	9,33	12,00	14,67
	22	2,13	3,47	4,80	6,13	7,47	8,80	11,47	14,13
	25	1,33	2,67	4,00	5,33	6,67	8,00	10,67	13,33
021.0	10	5,91	7,39	8,87	10,34	11,82	13,30	16,26	19,21
	15	4,43	5,91	7,39	8,87	10,34	11,82	14,78	17,73
	18	3,55	5,02	6,50	7,98	9,46	10,94	13,89	16,85
	20	2,96	4,43	5,91	7,39	8,87	10,34	13,30	16,26
	22	2,36	3,84	5,32	6,80	8,28	9,75	12,71	15,66
	25	1,48	2,96	4,43	5,91	7,39	8,87	11,82	14,78
025.0	10	6,89	8,61	10,33	12,06	13,78	15,50	18,94	22,39
	15	5,17	6,89	8,61	10,33	12,06	13,78	17,22	20,67
	18	4,13	5,86	7,58	9,30	11,02	12,74	16,19	19,63
	20	3,44	5,17	6,89	8,61	10,33	12,06	15,50	18,94
	22	2,76	4,48	6,20	7,92	9,64	11,37	14,81	18,26
	25	1,72	3,44	5,17	6,89	8,61	10,33	13,78	17,22
031.0	10	8,04	10,06	12,07	14,08	16,09	18,10	22,12	26,14
	15	6,03	8,04	10,06	12,07	14,08	16,09	20,11	24,13
	18	4,83	6,84	8,85	10,86	12,87	14,88	18,90	22,93
	20	4,02	6,03	8,04	10,06	12,07	14,08	18,10	22,12
	22	3,22	5,23	7,24	9,25	11,26	13,27	17,30	21,32
	25	2,01	4,02	6,03	8,04	10,06	12,07	16,09	20,11
041.0	10	9,38	11,72	14,07	16,41	18,76	21,10	25,79	30,48
	15	7,03	9,38	11,72	14,07	16,41	18,76	23,44	28,13
	18	5,63	7,97	10,32	12,66	15,00	17,35	22,04	26,73
	20	4,69	7,03	9,38	11,72	14,07	16,41	21,10	25,79
	22	3,75	6,10	8,44	10,78	13,13	15,47	20,16	24,85
	25	2,34	4,69	7,03	9,38	11,72	14,07	18,76	23,44
051.0	10	10,31	12,89	15,47	18,04	20,62	23,20	28,36	33,51
	15	7,73	10,31	12,89	15,47	18,04	20,62	25,78	30,93
	18	6,19	8,76	11,34	13,92	16,50	19,08	24,23	29,39
	20	5,16	7,73	10,31	12,89	15,47	18,04	23,20	28,36
	22	4,12	6,70	9,28	11,86	14,44	17,01	22,17	27,32
	25	2,58	5,16	7,73	10,31	12,89	15,47	20,62	25,78

Technical data referred to the following conditions:

Air flow at maximum speed (ESP = 0Pa)

Water temperature differential = 10°C

Ta = Air intake temperature

kW<sub>T</sub> = Thermal power in kW

# Performance - 4 pipe system (CC4)

## Cooling - AC fans (standard)

Size	Ta (°C) D.B. / W.B.	Inlet exchanger water temperature (°)									
		5		7		10		13		15	
		Total power [kW <sub>F</sub> ]	Sensible power [kW <sub>S</sub> ]	Total power [kW <sub>F</sub> ]	Sensible power [kW <sub>S</sub> ]	Total power [kW <sub>F</sub> ]	Sensible power [kW <sub>S</sub> ]	Total power [kW <sub>F</sub> ]	Sensible power [kW <sub>S</sub> ]	Total power [kW <sub>F</sub> ]	Sensible power [kW <sub>S</sub> ]
003.0	22 / 16	1,30	1,03	0,99	0,89	0,67	0,67	0,46	0,46	0,32	0,32
	24 / 17	1,45	1,17	1,14	1,03	0,81	0,81	0,60	0,60	0,46	0,46
	26 / 18	1,60	1,31	1,30	1,17	0,96	0,96	0,74	0,74	0,60	0,60
	27 / 19	1,76	1,38	1,45	1,24	1,03	1,03	0,81	0,81	0,67	0,67
	28 / 20	1,91	1,45	1,60	1,31	1,14	1,10	0,89	0,89	0,74	0,74
	30 / 22	2,21	1,59	1,91	1,45	1,45	1,24	1,03	1,03	0,89	0,89
005.0	22 / 16	1,74	1,30	1,33	1,12	0,85	0,85	0,58	0,58	0,40	0,40
	24 / 17	1,94	1,48	1,53	1,30	1,03	1,03	0,76	0,76	0,58	0,58
	26 / 18	2,14	1,66	1,74	1,48	1,21	1,21	0,94	0,94	0,76	0,76
	27 / 19	2,35	1,75	1,94	1,57	1,33	1,30	1,03	1,03	0,85	0,85
	28 / 20	2,55	1,84	2,14	1,66	1,53	1,39	1,12	1,12	0,94	0,94
	30 / 22	2,96	2,02	2,55	1,84	1,94	1,57	1,33	1,30	1,12	1,12
007.0	22 / 16	2,21	1,67	1,69	1,44	1,10	1,10	0,75	0,75	0,52	0,52
	24 / 17	2,47	1,90	1,95	1,67	1,33	1,33	0,98	0,98	0,75	0,75
	26 / 18	2,73	2,14	2,21	1,90	1,56	1,56	1,21	1,21	0,98	0,98
	27 / 19	2,99	2,25	2,47	2,02	1,69	1,67	1,33	1,33	1,10	1,10
	28 / 20	3,25	2,37	2,73	2,14	1,95	1,79	1,44	1,44	1,21	1,21
	30 / 22	3,77	2,60	3,25	2,37	2,47	2,02	1,69	1,67	1,44	1,44
009.0	22 / 16	2,61	1,84	2,00	1,59	1,21	1,21	0,82	0,82	0,57	0,57
	24 / 17	2,92	2,09	2,31	1,84	1,46	1,46	1,08	1,08	0,82	0,82
	26 / 18	3,23	2,35	2,61	2,09	1,71	1,71	1,33	1,33	1,08	1,08
	27 / 19	3,53	2,47	2,92	2,22	2,00	1,84	1,46	1,46	1,21	1,21
	28 / 20	3,84	2,60	3,23	2,35	2,31	1,97	1,59	1,59	1,33	1,33
	30 / 22	4,46	2,85	3,84	2,60	2,92	2,22	2,00	1,84	1,59	1,59
011.0	22 / 16	3,27	2,30	2,50	1,99	1,51	1,51	1,03	1,03	0,71	0,71
	24 / 17	3,65	2,62	2,88	2,30	1,83	1,83	1,35	1,35	1,03	1,03
	26 / 18	4,03	2,94	3,27	2,62	2,14	2,14	1,67	1,67	1,35	1,35
	27 / 19	4,42	3,10	3,65	2,78	2,50	2,30	1,83	1,83	1,51	1,51
	28 / 20	4,80	3,26	4,03	2,94	2,88	2,46	1,99	1,99	1,67	1,67
	30 / 22	5,57	3,57	4,80	3,26	3,65	2,78	2,50	2,30	1,99	1,99
015.0	22 / 16	3,68	2,58	2,81	2,22	1,69	1,69	1,16	1,16	0,80	0,80
	24 / 17	4,11	2,93	3,24	2,58	2,04	2,04	1,51	1,51	1,16	1,16
	26 / 18	4,54	3,29	3,68	2,93	2,40	2,40	1,87	1,87	1,51	1,51
	27 / 19	4,98	3,47	4,11	3,11	2,81	2,58	2,04	2,04	1,69	1,69
	28 / 20	5,41	3,64	4,54	3,29	3,24	2,75	2,22	2,22	1,87	1,87
	30 / 22	6,27	4,00	5,41	3,64	4,11	3,11	2,81	2,58	2,22	2,22

Technical data referred to the following conditions:

Air flow at maximum speed (ESP = 0Pa)

Water temperature differential = 5°C

Ta = Air intake temperature

WB = wet bulb

DB = dry bulb

kW<sub>F</sub> = Cooling capacity in kW

kW<sub>S</sub> = Sensible cooling capacity (kW)

# Performance - 4 pipe system (CC4)

## Cooling - AC fans (standard)

Size	Ta (°C) D.B. / W.B.	Inlet exchanger water temperature (°)									
		5		7		10		13		15	
		Total power [kW <sub>f</sub> ]	Sensible power [kW <sub>s</sub> ]	Total power [kW <sub>f</sub> ]	Sensible power [kW <sub>s</sub> ]	Total power [kW <sub>f</sub> ]	Sensible power [kW <sub>s</sub> ]	Total power [kW <sub>f</sub> ]	Sensible power [kW <sub>s</sub> ]	Total power [kW <sub>f</sub> ]	Sensible power [kW <sub>s</sub> ]
017.0	22 / 16	4,82	3,49	3,69	3,01	2,29	2,29	1,56	1,56	1,08	1,08
	24 / 17	5,39	3,97	4,26	3,49	2,77	2,77	2,04	2,04	1,56	1,56
	26 / 18	5,96	4,45	4,82	3,97	3,25	3,25	2,53	2,53	2,04	2,04
	27 / 19	6,52	4,69	5,39	4,21	3,69	3,49	2,77	2,77	2,29	2,29
	28 / 20	7,09	4,93	5,96	4,45	4,26	3,73	3,01	3,01	2,53	2,53
	30 / 22	8,23	5,41	7,09	4,93	5,39	4,21	3,69	3,49	3,01	3,01
021.0	22 / 16	5,57	3,84	4,26	3,31	2,52	2,52	1,72	1,72	1,19	1,19
	24 / 17	6,23	4,37	4,92	3,84	3,05	3,05	2,25	2,25	1,72	1,72
	26 / 18	6,89	4,91	5,57	4,37	3,61	3,58	2,78	2,78	2,25	2,25
	27 / 19	7,54	5,17	6,23	4,64	4,26	3,84	3,05	3,05	2,52	2,52
	28 / 20	8,20	5,44	6,89	4,91	4,92	4,11	3,31	3,31	2,78	2,78
	30 / 22	9,51	5,97	8,20	5,44	6,23	4,64	4,26	3,84	3,31	3,31
025.0	22 / 16	6,58	4,57	5,03	3,94	3,00	3,00	2,05	2,05	1,42	1,42
	24 / 17	7,35	5,20	5,80	4,57	3,63	3,63	2,68	2,68	2,05	2,05
	26 / 18	8,12	5,84	6,58	5,20	4,26	4,26	3,31	3,31	2,68	2,68
	27 / 19	8,90	6,15	7,35	5,52	5,03	4,57	3,63	3,63	3,00	3,00
	28 / 20	9,67	6,47	8,12	5,84	5,80	4,89	3,94	3,94	3,31	3,31
	30 / 22	11,22	7,10	9,67	6,47	7,35	5,52	5,03	4,57	3,94	3,94
031.0	22 / 16	7,88	5,34	6,03	4,60	3,50	3,50	2,39	2,39	1,66	1,66
	24 / 17	8,81	6,07	6,96	5,34	4,23	4,23	3,13	3,13	2,39	2,39
	26 / 18	9,74	6,81	7,88	6,07	5,10	4,97	3,86	3,86	3,13	3,13
	27 / 19	10,66	7,18	8,81	6,44	6,03	5,34	4,23	4,23	3,50	3,50
	28 / 20	11,59	7,54	9,74	6,81	6,96	5,70	4,60	4,60	3,86	3,86
	30 / 22	13,45	8,28	11,59	7,54	8,81	6,44	6,03	5,34	4,60	4,60
041.0	22 / 16	8,43	6,19	6,45	5,34	4,06	4,06	2,77	2,77	1,92	1,92
	24 / 17	9,42	7,04	7,44	6,19	4,91	4,91	3,63	3,63	2,77	2,77
	26 / 18	10,41	7,90	8,43	7,04	5,76	5,76	4,48	4,48	3,63	3,63
	27 / 19	11,40	8,32	9,42	7,47	6,45	6,19	4,91	4,91	4,06	4,06
	28 / 20	12,39	8,75	10,41	7,90	7,44	6,62	5,34	5,34	4,48	4,48
	30 / 22	14,38	9,60	12,39	8,75	9,42	7,47	6,45	6,19	5,34	5,34
051.0	22 / 16	9,40	6,78	7,19	5,84	4,44	4,44	3,04	3,04	2,10	2,10
	24 / 17	10,51	7,71	8,30	6,78	5,38	5,38	3,97	3,97	3,04	3,04
	26 / 18	11,62	8,65	9,40	7,71	6,31	6,31	4,91	4,91	3,97	3,97
	27 / 19	12,72	9,11	10,51	8,18	7,19	6,78	5,38	5,38	4,44	4,44
	28 / 20	13,83	9,58	11,62	8,65	8,30	7,25	5,84	5,84	4,91	4,91
	30 / 22	16,04	10,52	13,83	9,58	10,51	8,18	7,19	6,78	5,84	5,84

Technical data referred to the following conditions:

Air flow at maximum speed (ESP = 0Pa)

Water temperature differential = 5°C

Ta = Air intake temperature

WB = wet bulb

DB = dry bulb

kW<sub>f</sub> = Cooling capacity in kW

kW<sub>s</sub> = Sensible cooling capacity (kW)

# Performance - 4 pipe system (CC4)

## Heating - AC fans (standard)

Size	Ta (°C)	Inlet exchanger water temperature (°C)							
		35	40	45	50	55	60	70	80
		Total power [kW <sub>T</sub> ]	Total power [kW <sub>T</sub> ]	Total power [kW <sub>T</sub> ]	Total power [kW <sub>T</sub> ]	Total power [kW <sub>T</sub> ]	Total power [kW <sub>T</sub> ]	Total power [kW <sub>T</sub> ]	Total power [kW <sub>T</sub> ]
003.0	10	0,84	1,04	1,25	1,46	1,67	1,88	2,30	2,72
	15	0,63	0,84	1,04	1,25	1,46	1,67	2,09	2,51
	18	0,50	0,71	0,92	1,13	1,34	1,55	1,96	2,38
	20	0,42	0,63	0,84	1,04	1,25	1,46	1,88	2,30
	22	0,33	0,54	0,75	0,96	1,17	1,38	1,80	2,21
	25	0,21	0,42	0,63	0,84	1,04	1,25	1,67	2,09
005.0	10	0,88	1,10	1,32	1,54	1,76	1,98	2,42	2,86
	15	0,66	0,88	1,10	1,32	1,54	1,76	2,20	2,64
	18	0,53	0,75	0,97	1,19	1,41	1,63	2,07	2,51
	20	0,44	0,66	0,88	1,10	1,32	1,54	1,98	2,42
	22	0,35	0,57	0,79	1,01	1,23	1,45	1,89	2,33
	25	0,22	0,44	0,66	0,88	1,10	1,32	1,76	2,20
007.0	10	1,41	1,77	2,12	2,47	2,83	3,18	3,89	4,59
	15	1,06	1,41	1,77	2,12	2,47	2,83	3,53	4,24
	18	0,85	1,20	1,55	1,91	2,26	2,61	3,32	4,03
	20	0,71	1,06	1,41	1,77	2,12	2,47	3,18	3,89
	22	0,57	0,92	1,27	1,63	1,98	2,33	3,04	3,75
	25	0,35	0,71	1,06	1,41	1,77	2,12	2,83	3,53
009.0	10	1,49	1,86	2,23	2,61	2,98	3,35	4,09	4,84
	15	1,12	1,49	1,86	2,23	2,61	2,98	3,72	4,47
	18	0,89	1,27	1,64	2,01	2,38	2,75	3,50	4,24
	20	0,74	1,12	1,49	1,86	2,23	2,61	3,35	4,09
	22	0,60	0,97	1,34	1,71	2,08	2,46	3,20	3,95
	25	0,37	0,74	1,12	1,49	1,86	2,23	2,98	3,72
011.0	10	1,95	2,43	2,92	3,41	3,89	4,38	5,35	6,33
	15	1,46	1,95	2,43	2,92	3,41	3,89	4,87	5,84
	18	1,17	1,65	2,14	2,63	3,11	3,60	4,57	5,55
	20	0,97	1,46	1,95	2,43	2,92	3,41	4,38	5,35
	22	0,78	1,27	1,75	2,24	2,73	3,21	4,19	5,16
	25	0,49	0,97	1,46	1,95	2,43	2,92	3,89	4,87
015.0	10	2,02	2,53	3,03	3,54	4,04	4,55	5,56	6,57
	15	1,52	2,02	2,53	3,03	3,54	4,04	5,06	6,07
	18	1,21	1,72	2,22	2,73	3,24	3,74	4,75	5,76
	20	1,01	1,52	2,02	2,53	3,03	3,54	4,55	5,56
	22	0,81	1,31	1,82	2,33	2,83	3,34	4,35	5,36
	25	0,51	1,01	1,52	2,02	2,53	3,03	4,04	5,06

Technical data referred to the following conditions:

Air flow at maximum speed (ESP = 0Pa)

Water temperature differential = 10°C

Ta = Air intake temperature

kW<sub>T</sub> = Thermal power in kW

# Performance - 4 pipe system (CC4)

## Heating - AC fans (standard)

Size	Ta (°C)	Inlet exchanger water temperature (°)							
		35	40	45	50	55	60	70	80
		Total power [kW <sub>T</sub> ]	Total power [kW <sub>T</sub> ]	Total power [kW <sub>T</sub> ]	Total power [kW <sub>T</sub> ]	Total power [kW <sub>T</sub> ]	Total power [kW <sub>T</sub> ]	Total power [kW <sub>T</sub> ]	Total power [kW <sub>T</sub> ]
017.0	10	2,80	3,49	4,19	4,89	5,59	6,29	7,69	9,09
	15	2,10	2,80	3,49	4,19	4,89	5,59	6,99	8,39
	18	1,68	2,38	3,08	3,77	4,47	5,17	6,57	7,97
	20	1,40	2,10	2,80	3,49	4,19	4,89	6,29	7,69
	22	1,12	1,82	2,52	3,21	3,91	4,61	6,01	7,41
021.0	25	0,70	1,40	2,10	2,80	3,49	4,19	5,59	6,99
	10	2,87	3,59	4,31	5,02	5,74	6,46	7,90	9,33
	15	2,15	2,87	3,59	4,31	5,02	5,74	7,18	8,61
	18	1,72	2,44	3,16	3,88	4,59	5,31	6,75	8,18
	20	1,44	2,15	2,87	3,59	4,31	5,02	6,46	7,90
025.0	22	1,15	1,87	2,58	3,30	4,02	4,74	6,17	7,61
	25	0,72	1,44	2,15	2,87	3,59	4,31	5,74	7,18
	10	3,55	4,44	5,33	6,21	7,10	7,99	9,77	11,54
	15	2,66	3,55	4,44	5,33	6,21	7,10	8,88	10,65
	18	2,13	3,02	3,91	4,79	5,68	6,57	8,35	10,12
031.0	20	1,78	2,66	3,55	4,44	5,33	6,21	7,99	9,77
	22	1,42	2,31	3,20	4,08	4,97	5,86	7,63	9,41
	25	0,89	1,78	2,66	3,55	4,44	5,33	7,10	8,88
	10	3,60	4,51	5,41	6,31	7,21	8,11	9,91	11,71
	15	2,70	3,60	4,51	5,41	6,31	7,21	9,01	10,81
041.0	18	2,16	3,06	3,96	4,87	5,77	6,67	8,47	10,27
	20	1,80	2,70	3,60	4,51	5,41	6,31	8,11	9,91
	22	1,44	2,34	3,24	4,15	5,05	5,95	7,75	9,55
	25	0,90	1,80	2,70	3,60	4,51	5,41	7,21	9,01
	10	4,93	6,16	7,39	8,63	9,86	11,09	13,55	16,02
051.0	15	3,70	4,93	6,16	7,39	8,63	9,86	12,32	14,79
	18	2,96	4,19	5,42	6,65	7,89	9,12	11,58	14,05
	20	2,46	3,70	4,93	6,16	7,39	8,63	11,09	13,55
	22	1,97	3,20	4,44	5,67	6,90	8,13	10,60	13,06
	25	1,23	2,46	3,70	4,93	6,16	7,39	9,86	12,32
051.0	10	4,98	6,22	7,47	8,71	9,96	11,20	13,69	16,18
	15	3,73	4,98	6,22	7,47	8,71	9,96	12,44	14,93
	18	2,99	4,23	5,48	6,72	7,96	9,21	11,70	14,19
	20	2,49	3,73	4,98	6,22	7,47	8,71	11,20	13,69
	22	1,99	3,24	4,48	5,72	6,97	8,21	10,70	13,19
051.0	25	1,24	2,49	3,73	4,98	6,22	7,47	9,96	12,44

Technical data referred to the following conditions:

Air flow at maximum speed (ESP = 0Pa)

Water temperature differential = 10°C

Ta = Air intake temperature

kW<sub>T</sub> = Thermal power in kW

# Performance correction coefficients as a function of air flow and external static pressure

## 2 pipe system - Standard AC fan

ESP (Pa)	Fan speed	Size																	
		003.0			005.0			007.0			009.0			011.0			015.0		
		P <sub>F</sub>	P <sub>S</sub>	P <sub>T</sub>	P <sub>F</sub>	P <sub>S</sub>	P <sub>T</sub>	P <sub>F</sub>	P <sub>S</sub>	P <sub>T</sub>	P <sub>F</sub>	P <sub>S</sub>	P <sub>T</sub>	P <sub>F</sub>	P <sub>S</sub>	P <sub>T</sub>	P <sub>F</sub>	P <sub>S</sub>	P <sub>T</sub>
0	Max	1,00	1,00	1,00	1,00	1,00	1,00	1,00	1,00	1,00	1,00	1,00	1,00	1,00	1,00	1,00	1,00	1,00	1,00
	Mid	0,85	0,83	0,84	0,85	0,83	0,84	0,87	0,85	0,86	0,87	0,85	0,86	0,92	0,91	0,92	0,92	0,91	0,92
	Min	0,73	0,70	0,72	0,73	0,70	0,72	0,73	0,70	0,72	0,73	0,70	0,72	0,80	0,77	0,79	0,80	0,77	0,79
10	Max	0,98	0,97	0,98	0,98	0,97	0,98	0,97	0,96	0,96	0,97	0,96	0,96	0,97	0,96	0,96	0,97	0,96	0,96
	Mid	0,82	0,79	0,81	0,82	0,79	0,81	0,83	0,80	0,82	0,83	0,80	0,82	0,87	0,85	0,87	0,87	0,85	0,87
	Min	0,68	0,64	0,66	0,68	0,64	0,66	0,69	0,65	0,67	0,69	0,65	0,67	0,74	0,71	0,73	0,74	0,71	0,73
20	Max	0,94	0,94	0,94	0,94	0,94	0,94	0,93	0,92	0,93	0,93	0,92	0,93	0,93	0,92	0,92	0,93	0,92	0,92
	Mid	0,77	0,74	0,76	0,77	0,74	0,76	0,78	0,75	0,77	0,78	0,75	0,77	0,82	0,80	0,81	0,82	0,80	0,81
	Min	0,60	0,56	0,58	0,61	0,56	0,59	0,63	0,59	0,61	0,63	0,59	0,61	0,67	0,63	0,66	0,67	0,63	0,66
30	Max	0,90	0,89	0,90	0,90	0,89	0,90	0,89	0,87	0,88	0,89	0,87	0,88	0,88	0,86	0,87	0,88	0,86	0,87
	Mid	0,72	0,69	0,71	0,72	0,69	0,71	0,74	0,70	0,72	0,74	0,70	0,72	0,77	0,74	0,76	0,77	0,74	0,76
	Min	0,54	0,49	0,52	0,54	0,49	0,52	0,57	0,53	0,55	0,57	0,53	0,55	0,61	0,57	0,59	0,61	0,57	0,59
40	Max	0,86	0,84	0,85	0,86	0,84	0,85	0,84	0,81	0,83	0,84	0,81	0,83	0,83	0,81	0,82	0,83	0,81	0,82
	Mid	0,68	0,64	0,66	0,68	0,64	0,66	0,68	0,64	0,66	0,68	0,64	0,66	0,72	0,69	0,71	0,72	0,69	0,71
	Min	0,46	0,41	0,44	0,46	0,41	0,44	0,50	0,45	0,48	0,50	0,45	0,48	0,54	0,49	0,52	0,54	0,49	0,52
50	Max	0,81	0,78	0,80	0,81	0,78	0,80	0,78	0,75	0,77	0,78	0,75	0,77	0,77	0,74	0,76	0,77	0,74	0,76
	Mid	0,60	0,55	0,58	0,60	0,55	0,58	0,62	0,58	0,61	0,62	0,58	0,61	0,66	0,61	0,64	0,66	0,61	0,64
	Min	0,39	0,34	0,37	0,39	0,34	0,37	0,40	0,35	0,38	0,40	0,35	0,38	0,47	0,42	0,45	0,47	0,42	0,45
60	Max	0,73	0,70	0,72	0,73	0,70	0,72	0,71	0,67	0,69	0,71	0,67	0,69	0,71	0,67	0,70	0,71	0,67	0,70
	Mid	0,53	0,48	0,51	0,53	0,48	0,51	0,55	0,50	0,53	0,55	0,50	0,53	0,60	0,55	0,58	0,60	0,55	0,58
	Min	n.d.	n.d.	n.d.	n.d.	n.d.	n.d.	n.d.	n.d.	n.d.	n.d.	n.d.	n.d.	0,39	0,34	0,37	0,39	0,34	0,37
70	Max	0,62	0,57	0,60	0,62	0,57	0,60	0,61	0,57	0,59	0,61	0,57	0,59	0,64	0,60	0,62	0,64	0,60	0,62
	Mid	0,42	0,37	0,40	0,42	0,37	0,40	0,44	0,39	0,42	0,44	0,39	0,42	0,53	0,48	0,51	0,53	0,48	0,51
	Min	n.d.	n.d.	n.d.	n.d.	n.d.	n.d.	n.d.	n.d.	n.d.	n.d.	n.d.	n.d.	n.d.	n.d.	n.d.	n.d.	n.d.	n.d.
80	Max	0,50	0,44	0,47	0,50	0,44	0,47	0,49	0,44	0,47	0,49	0,44	0,47	0,55	0,50	0,53	0,55	0,50	0,53
	Mid	n.d.	n.d.	n.d.	n.d.	n.d.	n.d.	n.d.	n.d.	n.d.	n.d.	n.d.	n.d.	0,44	0,39	0,42	0,44	0,39	0,42
	Min	n.d.	n.d.	n.d.	n.d.	n.d.	n.d.	n.d.	n.d.	n.d.	n.d.	n.d.	n.d.	n.d.	n.d.	n.d.	n.d.	n.d.	n.d.
90	Max	n.d.	n.d.	n.d.	n.d.	n.d.	n.d.	n.d.	n.d.	n.d.	n.d.	n.d.	n.d.	0,47	0,41	0,44	0,47	0,41	0,44
	Mid	n.d.	n.d.	n.d.	n.d.	n.d.	n.d.	n.d.	n.d.	n.d.	n.d.	n.d.	n.d.	0,35	0,30	0,33	0,35	0,30	0,33
	Min	n.d.	n.d.	n.d.	n.d.	n.d.	n.d.	n.d.	n.d.	n.d.	n.d.	n.d.	n.d.	n.d.	n.d.	n.d.	n.d.	n.d.	n.d.

Technical data referred to the following conditions:

Cooling: Indoor air temperature at 27°C D.B. / 19°C W.B.

Water temperature in / out 7°C / 12°C

Heating: Indoor air temperature 20°C

Water temperature in / out 70°C / 60°C

PF = Cooling capacity

PS = Sensible cooling capacity

PT = Heating capacity

# Performance correction coefficients as a function of air flow and external static pressure

## 4 pipe system - Standard AC fan

ESP (Pa)	Fan speed	Size																	
		017.0			021.0			025.0			031.0			041.0			051.0		
		P <sub>F</sub>	P <sub>S</sub>	P <sub>T</sub>	P <sub>F</sub>	P <sub>S</sub>	P <sub>T</sub>	P <sub>F</sub>	P <sub>S</sub>	P <sub>T</sub>	P <sub>F</sub>	P <sub>S</sub>	P <sub>T</sub>	P <sub>F</sub>	P <sub>S</sub>	P <sub>T</sub>	P <sub>F</sub>	P <sub>S</sub>	P <sub>T</sub>
0	Max	1,00	1,00	1,00	1,00	1,00	1,00	1,00	1,00	1,00	1,00	1,00	1,00	1,00	1,00	1,00	1,00	1,00	1,00
	Mid	0,93	0,92	0,93	0,93	0,92	0,93	0,93	0,92	0,92	0,93	0,92	0,92	0,91	0,89	0,90	0,91	0,89	0,90
	Min	0,77	0,74	0,76	0,77	0,74	0,76	0,79	0,76	0,77	0,79	0,76	0,77	0,86	0,84	0,85	0,86	0,84	0,85
10	Max	0,96	0,96	0,96	0,96	0,96	0,96	0,97	0,97	0,97	0,97	0,97	0,97	0,98	0,97	0,97	0,98	0,97	0,97
	Mid	0,88	0,87	0,88	0,88	0,87	0,88	0,91	0,89	0,90	0,91	0,89	0,90	0,89	0,88	0,89	0,89	0,88	0,89
	Min	0,73	0,69	0,71	0,73	0,69	0,71	0,76	0,73	0,75	0,76	0,73	0,75	0,84	0,82	0,83	0,84	0,82	0,83
20	Max	0,93	0,92	0,92	0,93	0,92	0,92	0,95	0,94	0,94	0,95	0,94	0,94	0,96	0,95	0,96	0,96	0,95	0,96
	Mid	0,84	0,82	0,83	0,84	0,82	0,83	0,89	0,87	0,88	0,89	0,87	0,88	0,88	0,86	0,87	0,88	0,86	0,87
	Min	0,69	0,65	0,67	0,69	0,65	0,67	0,74	0,71	0,73	0,74	0,71	0,73	0,82	0,79	0,81	0,82	0,79	0,81
30	Max	0,89	0,88	0,89	0,89	0,88	0,89	0,92	0,90	0,91	0,92	0,90	0,91	0,94	0,93	0,93	0,94	0,93	0,93
	Mid	0,80	0,78	0,79	0,80	0,78	0,79	0,86	0,85	0,86	0,86	0,85	0,86	0,86	0,84	0,85	0,86	0,84	0,85
	Min	0,65	0,61	0,64	0,65	0,61	0,64	0,72	0,68	0,70	0,72	0,68	0,70	0,80	0,77	0,79	0,80	0,77	0,79
40	Max	0,85	0,83	0,84	0,85	0,83	0,84	0,88	0,87	0,88	0,88	0,87	0,88	0,91	0,89	0,90	0,91	0,89	0,90
	Mid	0,76	0,73	0,75	0,76	0,73	0,75	0,83	0,81	0,82	0,83	0,81	0,82	0,83	0,81	0,82	0,83	0,81	0,82
	Min	0,60	0,56	0,58	0,60	0,56	0,58	0,68	0,64	0,67	0,68	0,64	0,67	0,78	0,75	0,76	0,78	0,75	0,76
50	Max	0,80	0,77	0,79	0,80	0,77	0,79	0,84	0,82	0,83	0,84	0,82	0,83	0,87	0,85	0,86	0,87	0,85	0,86
	Mid	0,71	0,68	0,70	0,71	0,68	0,70	0,79	0,76	0,78	0,79	0,76	0,78	0,80	0,77	0,79	0,80	0,77	0,79
	Min	0,55	0,50	0,53	0,55	0,50	0,53	0,65	0,60	0,63	0,65	0,60	0,63	0,75	0,71	0,73	0,75	0,71	0,73
60	Max	0,74	0,71	0,73	0,74	0,71	0,73	0,79	0,77	0,78	0,79	0,77	0,78	0,82	0,80	0,81	0,82	0,80	0,81
	Mid	0,65	0,61	0,64	0,65	0,61	0,64	0,74	0,70	0,72	0,74	0,70	0,72	0,75	0,72	0,74	0,75	0,72	0,74
	Min	0,49	0,44	0,47	0,49	0,44	0,47	0,61	0,56	0,59	0,61	0,56	0,59	0,70	0,66	0,68	0,70	0,66	0,68
70	Max	0,68	0,64	0,67	0,68	0,64	0,67	0,73	0,69	0,71	0,73	0,69	0,71	0,77	0,74	0,76	0,77	0,74	0,76
	Mid	0,58	0,54	0,56	0,58	0,54	0,56	0,68	0,64	0,66	0,68	0,64	0,66	0,70	0,66	0,68	0,70	0,66	0,68
	Min	0,42	0,37	0,40	0,42	0,37	0,40	0,56	0,51	0,54	0,56	0,51	0,54	0,65	0,60	0,63	0,65	0,60	0,63
80	Max	0,61	0,56	0,59	0,61	0,56	0,59	0,67	0,63	0,65	0,67	0,63	0,65	0,72	0,68	0,70	0,72	0,68	0,70
	Mid	0,51	0,46	0,49	0,51	0,46	0,49	0,61	0,57	0,59	0,61	0,57	0,59	0,64	0,60	0,62	0,64	0,60	0,62
	Min	0,34	0,28	0,31	0,34	0,28	0,31	0,50	0,45	0,48	0,50	0,45	0,48	0,59	0,55	0,57	0,59	0,55	0,57
90	Max	0,51	0,46	0,49	0,51	0,46	0,49	0,58	0,53	0,56	0,58	0,53	0,56	0,63	0,58	0,61	0,63	0,58	0,61
	Mid	0,42	0,36	0,39	0,42	0,36	0,39	0,52	0,47	0,50	0,52	0,47	0,50	0,54	0,49	0,52	0,54	0,49	0,52
	Min	n.d.	n.d.	n.d.	n.d.	n.d.	n.d.	0,42	0,37	0,40	0,42	0,37	0,40	0,52	0,47	0,50	0,52	0,47	0,50

Technical data referred to the following conditions:

Cooling: Indoor air temperature at 27°C D.B. / 19°C W.B.

Water temperature in / out 7°C / 12°C

Heating: Indoor air temperature 20°C

Water temperature in / out 70°C / 60°C

PF = Cooling capacity

PS = Sensible cooling capacity

PT = Heating capacity

# Performance correction coefficients as a function of air flow and external static pressure

## 4 pipe system - Standard AC fan

ESP (Pa)	Fan speed	Size																	
		003.0			005.0			007.0			009.0			011.0			015.0		
		P <sub>F</sub>	P <sub>S</sub>	P <sub>T</sub>	P <sub>F</sub>	P <sub>S</sub>	P <sub>T</sub>	P <sub>F</sub>	P <sub>S</sub>	P <sub>T</sub>	P <sub>F</sub>	P <sub>S</sub>	P <sub>T</sub>	P <sub>F</sub>	P <sub>S</sub>	P <sub>T</sub>	P <sub>F</sub>	P <sub>S</sub>	P <sub>T</sub>
0	Max	1,00	1,00	1,00	1,00	1,00	1,00	1,00	1,00	1,00	1,00	1,00	1,00	1,00	1,00	1,00	1,00	1,00	1,00
	Mid	0,85	0,83	0,85	0,85	0,83	0,85	0,87	0,85	0,86	0,87	0,85	0,86	0,92	0,91	0,91	0,92	0,91	0,91
	Min	0,73	0,70	0,72	0,73	0,70	0,72	0,74	0,71	0,73	0,74	0,71	0,73	0,80	0,77	0,79	0,80	0,77	0,79
10	Max	0,97	0,96	0,97	0,97	0,97	0,97	0,97	0,96	0,97	0,97	0,96	0,97	0,97	0,96	0,96	0,97	0,96	0,96
	Mid	0,81	0,79	0,80	0,81	0,79	0,80	0,83	0,81	0,82	0,83	0,81	0,82	0,87	0,85	0,86	0,87	0,85	0,86
	Min	0,68	0,64	0,66	0,68	0,64	0,66	0,69	0,65	0,67	0,69	0,65	0,68	0,74	0,71	0,73	0,74	0,71	0,73
20	Max	0,93	0,92	0,93	0,93	0,92	0,93	0,93	0,92	0,93	0,93	0,92	0,93	0,92	0,91	0,92	0,92	0,91	0,92
	Mid	0,77	0,74	0,76	0,77	0,74	0,76	0,78	0,76	0,77	0,79	0,76	0,77	0,82	0,80	0,81	0,82	0,80	0,81
	Min	0,61	0,56	0,59	0,61	0,56	0,59	0,64	0,59	0,62	0,64	0,60	0,62	0,68	0,64	0,66	0,68	0,64	0,66
30	Max	0,90	0,88	0,89	0,90	0,88	0,89	0,89	0,87	0,88	0,88	0,87	0,88	0,88	0,86	0,87	0,88	0,86	0,87
	Mid	0,73	0,69	0,71	0,73	0,69	0,71	0,74	0,71	0,73	0,74	0,71	0,73	0,78	0,75	0,76	0,78	0,75	0,76
	Min	0,54	0,50	0,52	0,54	0,50	0,52	0,58	0,54	0,56	0,58	0,54	0,56	0,62	0,57	0,60	0,62	0,57	0,60
40	Max	0,85	0,83	0,84	0,85	0,83	0,84	0,83	0,81	0,82	0,83	0,81	0,82	0,83	0,80	0,82	0,83	0,80	0,82
	Mid	0,67	0,63	0,65	0,67	0,63	0,65	0,68	0,65	0,67	0,69	0,65	0,67	0,72	0,69	0,71	0,72	0,69	0,71
	Min	0,47	0,42	0,45	0,47	0,41	0,44	0,50	0,45	0,48	0,51	0,46	0,49	0,54	0,50	0,52	0,55	0,50	0,53
50	Max	0,79	0,76	0,78	0,79	0,76	0,78	0,78	0,75	0,76	0,77	0,74	0,76	0,77	0,74	0,76	0,77	0,74	0,76
	Mid	0,60	0,56	0,58	0,60	0,56	0,58	0,63	0,58	0,61	0,63	0,58	0,61	0,66	0,62	0,64	0,66	0,62	0,64
	Min	0,40	0,34	0,38	0,40	0,34	0,37	0,41	0,36	0,39	0,41	0,36	0,39	0,48	0,43	0,46	0,48	0,43	0,46
60	Max	0,71	0,67	0,69	0,71	0,67	0,69	0,70	0,67	0,69	0,70	0,66	0,69	0,71	0,68	0,70	0,71	0,68	0,70
	Mid	0,53	0,48	0,51	0,53	0,48	0,51	0,55	0,50	0,53	0,55	0,50	0,53	0,61	0,56	0,59	0,61	0,56	0,59
	Min	n.d.	n.d.	n.d.	n.d.	n.d.	n.d.	n.d.	n.d.	n.d.	n.d.	n.d.	n.d.	0,40	0,35	0,38	0,40	0,35	0,38
70	Max	0,61	0,56	0,59	0,61	0,56	0,59	0,61	0,57	0,59	0,61	0,56	0,59	0,64	0,60	0,62	0,64	0,60	0,62
	Mid	0,43	0,37	0,40	0,43	0,37	0,40	0,44	0,39	0,42	0,45	0,39	0,42	0,54	0,49	0,52	0,54	0,49	0,52
	Min	n.d.	n.d.	n.d.	n.d.	n.d.	n.d.	n.d.	n.d.	n.d.	n.d.	n.d.	n.d.	n.d.	n.d.	n.d.	n.d.	n.d.	n.d.
80	Max	0,49	0,43	0,46	0,49	0,43	0,46	0,49	0,44	0,47	0,49	0,44	0,47	0,56	0,51	0,54	0,56	0,51	0,54
	Mid	n.d.	n.d.	n.d.	n.d.	n.d.	n.d.	n.d.	n.d.	n.d.	n.d.	n.d.	n.d.	0,45	0,40	0,43	0,45	0,40	0,43
	Min	n.d.	n.d.	n.d.	n.d.	n.d.	n.d.	n.d.	n.d.	n.d.	n.d.	n.d.	n.d.	n.d.	n.d.	n.d.	n.d.	n.d.	n.d.
90	Max	n.d.	n.d.	n.d.	n.d.	n.d.	n.d.	n.d.	n.d.	n.d.	n.d.	n.d.	n.d.	0,47	0,42	0,45	0,47	0,42	0,45
	Mid	n.d.	n.d.	n.d.	n.d.	n.d.	n.d.	n.d.	n.d.	n.d.	n.d.	n.d.	n.d.	0,36	0,31	0,34	0,36	0,31	0,34
	Min	n.d.	n.d.	n.d.	n.d.	n.d.	n.d.	n.d.	n.d.	n.d.	n.d.	n.d.	n.d.	n.d.	n.d.	n.d.	n.d.	n.d.	n.d.

Technical data referred to the following conditions:

Cooling: Indoor air temperature at 27°C D.B. / 19°C W.B.

Water temperature in / out 7°C / 12°C

Heating: Indoor air temperature 20°C

Water temperature in / out 70°C / 60°C

PF = Cooling capacity

PS = Sensible cooling capacity

PT = Heating capacity



# Performance correction coefficients as a function of air flow and external static pressure

## 4 pipe system - Standard AC fan

ESP (Pa)	Fan speed	Size																	
		017.0			021.0			025.0			031.0			041.0			051.0		
		P <sub>F</sub>	P <sub>S</sub>	P <sub>T</sub>	P <sub>F</sub>	P <sub>S</sub>	P <sub>T</sub>	P <sub>F</sub>	P <sub>S</sub>	P <sub>T</sub>	P <sub>F</sub>	P <sub>S</sub>	P <sub>T</sub>	P <sub>F</sub>	P <sub>S</sub>	P <sub>T</sub>	P <sub>F</sub>	P <sub>S</sub>	P <sub>T</sub>
0	Max	1,00	1,00	1,00	1,00	1,00	1,00	1,00	1,00	1,00	1,00	1,00	1,00	1,00	1,00	1,00	1,00	1,00	1,00
	Mid	0,93	0,92	0,92	0,93	0,91	0,92	0,93	0,93	0,93	0,93	0,93	0,93	0,92	0,91	0,91	0,92	0,91	0,91
	Min	0,78	0,75	0,76	0,78	0,75	0,76	0,79	0,77	0,78	0,79	0,77	0,78	0,87	0,85	0,86	0,87	0,85	0,86
10	Max	0,97	0,96	0,96	0,97	0,96	0,96	0,97	0,97	0,97	0,97	0,97	0,97	0,99	0,98	0,99	0,99	0,98	0,99
	Mid	0,89	0,87	0,88	0,89	0,87	0,88	0,92	0,90	0,91	0,92	0,90	0,91	0,91	0,89	0,90	0,90	0,89	0,90
	Min	0,74	0,70	0,72	0,74	0,70	0,72	0,77	0,74	0,76	0,77	0,74	0,76	0,84	0,82	0,84	0,84	0,82	0,84
20	Max	0,93	0,92	0,93	0,93	0,92	0,93	0,95	0,94	0,94	0,95	0,94	0,94	0,96	0,96	0,96	0,96	0,96	0,96
	Mid	0,85	0,83	0,84	0,85	0,83	0,84	0,90	0,88	0,89	0,90	0,88	0,89	0,88	0,87	0,88	0,88	0,87	0,88
	Min	0,70	0,66	0,68	0,70	0,66	0,68	0,75	0,72	0,74	0,75	0,72	0,74	0,83	0,81	0,82	0,83	0,81	0,82
30	Max	0,90	0,88	0,89	0,90	0,88	0,89	0,92	0,90	0,91	0,92	0,90	0,91	0,94	0,93	0,94	0,94	0,93	0,94
	Mid	0,81	0,78	0,80	0,81	0,78	0,80	0,87	0,85	0,86	0,87	0,85	0,86	0,87	0,85	0,86	0,87	0,85	0,86
	Min	0,66	0,62	0,64	0,66	0,62	0,65	0,72	0,69	0,71	0,72	0,69	0,71	0,81	0,78	0,80	0,81	0,78	0,80
40	Max	0,85	0,83	0,84	0,85	0,83	0,84	0,88	0,87	0,88	0,88	0,87	0,88	0,91	0,89	0,90	0,91	0,89	0,90
	Mid	0,77	0,74	0,75	0,77	0,74	0,75	0,83	0,81	0,82	0,83	0,81	0,82	0,84	0,81	0,83	0,84	0,81	0,83
	Min	0,61	0,57	0,59	0,61	0,57	0,60	0,69	0,65	0,67	0,69	0,65	0,67	0,78	0,75	0,77	0,78	0,75	0,77
50	Max	0,80	0,77	0,79	0,80	0,77	0,79	0,84	0,82	0,83	0,84	0,82	0,83	0,87	0,85	0,86	0,87	0,85	0,86
	Mid	0,72	0,68	0,71	0,72	0,69	0,71	0,79	0,76	0,78	0,79	0,76	0,78	0,80	0,77	0,79	0,80	0,77	0,79
	Min	0,56	0,51	0,54	0,56	0,51	0,54	0,65	0,61	0,64	0,65	0,61	0,64	0,75	0,72	0,74	0,75	0,72	0,74
60	Max	0,75	0,71	0,73	0,75	0,71	0,73	0,78	0,75	0,77	0,78	0,75	0,77	0,82	0,80	0,81	0,82	0,80	0,81
	Mid	0,66	0,62	0,64	0,66	0,62	0,64	0,73	0,70	0,72	0,73	0,70	0,72	0,75	0,72	0,74	0,75	0,72	0,74
	Min	0,50	0,44	0,47	0,50	0,45	0,48	0,61	0,57	0,59	0,61	0,57	0,59	0,70	0,66	0,69	0,70	0,66	0,68
70	Max	0,69	0,65	0,67	0,69	0,65	0,67	0,73	0,69	0,71	0,73	0,69	0,71	0,77	0,74	0,76	0,77	0,74	0,76
	Mid	0,59	0,54	0,57	0,59	0,55	0,57	0,68	0,64	0,66	0,68	0,64	0,66	0,70	0,66	0,68	0,70	0,66	0,68
	Min	0,43	0,38	0,41	0,43	0,38	0,41	0,56	0,51	0,54	0,56	0,51	0,54	0,65	0,61	0,63	0,65	0,61	0,63
80	Max	0,61	0,57	0,59	0,61	0,57	0,59	0,67	0,62	0,65	0,67	0,62	0,65	0,71	0,68	0,70	0,71	0,68	0,70
	Mid	0,51	0,46	0,49	0,51	0,46	0,49	0,61	0,57	0,59	0,61	0,57	0,59	0,64	0,60	0,62	0,64	0,60	0,62
	Min	0,34	0,29	0,32	0,34	0,29	0,32	0,50	0,45	0,48	0,50	0,45	0,48	0,60	0,55	0,58	0,60	0,55	0,58
90	Max	0,52	0,47	0,50	0,52	0,47	0,50	0,58	0,53	0,56	0,58	0,53	0,56	0,62	0,58	0,61	0,62	0,58	0,61
	Mid	0,42	0,37	0,40	0,42	0,37	0,40	0,52	0,47	0,50	0,52	0,47	0,50	0,54	0,50	0,52	0,54	0,50	0,52
	Min	n.d.	n.d.	n.d.	n.d.	n.d.	n.d.	0,43	0,37	0,40	0,43	0,37	0,40	0,52	0,47	0,50	0,52	0,47	0,50

Technical data referred to the following conditions:

Cooling: Indoor air temperature at 27°C D.B. / 19°C W.B.

Water temperature in / out 7°C / 12°C

Heating: Indoor air temperature 20°C

Water temperature in / out 70°C / 60°C

PF = Cooling capacity

PS = Sensible cooling capacity

PT = Heating capacity

## Configuration options

### TRM - Terminal block with minimum water temperature clickson

“Mammoth” type terminal board (min. 7 poles) IP20 with minimum hot water temperature thermostat (T. SET = 32°C).

This function disable the fan operation when, in heating mode, the water on the coil is not hot enough.

Function to prevent ventilation, of cold air in the room (because the water is too cold), which in winter it can be particularly annoying.

The probe which measures the minimum temperature is usually installed in contact with the heating coil, but according to the controllers maybe required the intallation on the inlet pipe unit (before any possible valve).

The “minimum hot water temperature” works only in heating mode. In cooling it is by-passed.

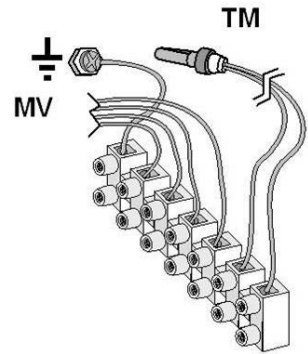

MV = Fan motor  
TM = Minimum water temperature clickson



If electronic CTS (CLIVET TALK TERMINAL SPACE) is present, isn't longer necessary this option because already included.

### TRP - Terminal block with closing cover IP40.

Terminal block type “Mammoth” (min. 7 poles) with closing cover IP40.

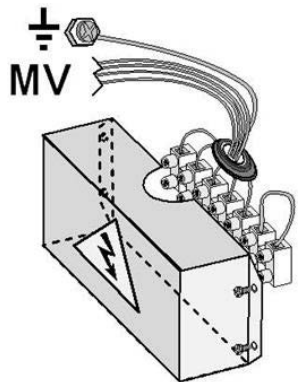

MV = Fan motor



If electronic CTS (CLIVET TALK TERMINAL SPACE) is present, isn't longer necessary this option because already included.

### TRMP - Terminal block with closing cover IP40 and minimum water temperature clickson

Terminal block type “Mammoth” (min. 7 poles) with closing cover IP40 and minimum water temperature clickson.

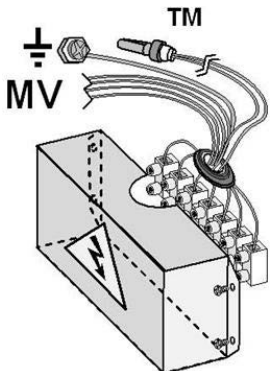

MV = Fan motor  
TM = Minimum water temperature clickson



If electronic CTS (CLIVET TALK TERMINAL SPACE) is present, isn't longer necessary this option because already included.

## HIDF1 - Control mounted on unit: 3 speed selector + off

Functions:

- 4-position switch (OFF/3 speed).

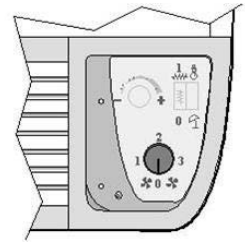

## HIDF2 - Control on the unit: BULB thermostat (3 speed + off + remote E/I + Temp.selection)

Functions:

- 4-position switch (OFF/3 speed);
- switch Summer/Winter;
- bulb thermostat on the intake;
- room temperature control.

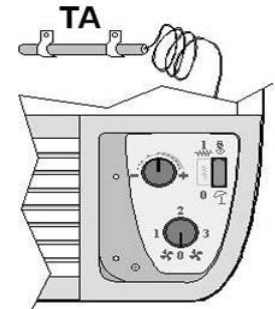

TA = Bulb thermostat

## HIDF4 - Control installed onboard unit: bulb thermostat (3 sp. + off + E/I + temp. sel.)+ minimum thermostat

Functions:

- 4-position switch (OFF/3 speed);
- switch Summer/Winter;
- bulb thermostat on the intake;
- room temperature control;
- minimum hot water temperature thermostat.

It is different from HID-F2 because the water min. temperature clickson is present.

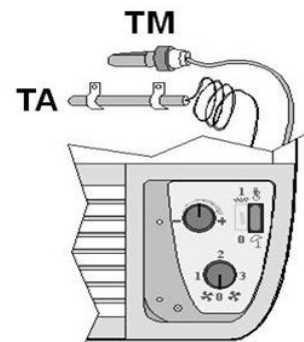

TA = Bulb thermostat  
TM = Minimum water temperature clickson

## HIDF5 - Control on the unit: BULB thermostat + on/off heaters

Functions:

- 4-position switch (OFF/3 speed);
- switch Summer/Winter;
- room temperature control;
- electric heater on/off control.

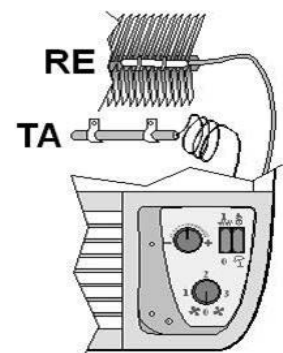

TA = Bulb thermostat  
RE = Electric heater

## HIDF6 - Control mounted on unit's side: multi-function electronic room thermostat

Configurable control panel to control units with 3-speed 230Vac motor, 2-4 pipes, with or without valves. All functions are adjustable/programmable and activatable/deactivatable:

- control 3-speed motor fan (manual/AUTO);
- valve management both for the 2 pipe and the 4 pipe systems;
- activation/deactivation of the antistratification function;
- always running or thermostated motor function (active/not active);
- AUTO speed steps (selectable);
- switch Summer/Winter (manual only);
- adjustable range of set point temperature (handle lock)
- control unit through remote room air temperature sensor (included);
- control unit through minimum hot water temperature thermostat TMX (accessories separately supplied).

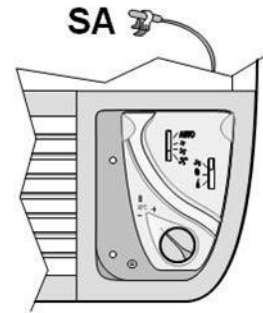

SA = Remote air probe (length 1m. Connected to the control panel protrudes from the unit of 50cm)

## HIDF7 - Built-in control: electronic thermostat with display

P+I microprocessor Hi-Tech controller, LCD display, pre-programmable, configurable to meet the requirements of different installations. Multi-functions, for the full control of 2-4 pipes unit, with or without valves.

Ideal to control units provided with electrical heater, due to the post-ventilation function (useful to cool down the electric heater thermal inertia).

Configurable functions:

- control 3-speed motor fan (manual/AUTO);
- valve management both for the 2 pipe and the 4 pipe systems;
- dirty filter alarm;
- anti-stratification function;
- economy function (night);
- set-point temperature range;
- measured air temperature correction;
- always running or thermostated motor function (active/not active);
- configurable Summer/Winter switch;
- post-ventilation (raccomended for units with electrical heaters);
- control unit through remote room air temperature sensor (included);
- control unit through minimum hot water temperature thermostat TMX (accessories separately supplied).

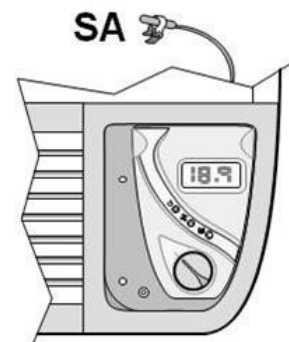

SA = Remote air probe (length 1m. Connected to the control panel protrudes from the unit of 50cm)

## HIDF8 - Control built-in installed: electronic thermostat with display for 0-10Vdc fan

This digital controller is intended for temperature regulation in environments equipped with fan-coil heat-cool exchangers. It controls in continuous proportional fashion the speed of high efficiency EC fan (VEC), in order to adjust the room temperature in the most suitable way. Equipped with LCD display, pre-programmable, configurable to meet the requirements of different installations. Multi-functions, with remote room air temperature sensor, for the full control of 2-4 pipes unit, with or without valves.

The HIDF8 allows the following functions:

- digital thermostat settable with manual or automatic selection of the 3 fan speeds
- manual, automatic or centralized summer/winter selection by an input, neutral zone and changeover on the supply water
- temperature control system on valves, fan or both
- LCD display with all functions displayed
- driving of On/Off valves, PWM, 3-point servo-control, 0-10V actuators, heaters, heat pumps
- special functions: economy, dirty filter warning, window contact or presence
- set-up for external and supply probe
- driving of the fan motor by 3 relays or proportional by 0-10V signal
- possibility to drive the fan motor at 230V~, the thermostat and the actuators at 24V~

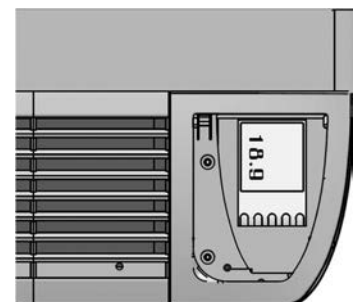

## CTSP1 - CLIVET TALK TERMINAL SPACE electronics with RS485 Modbus serial port

This is a card for control of the unit which, in addition to basic functions, allows it to be connected to a network of similar units managed centrally by ELFOControl or B.M.S.

This type of electronic card is suited for communicating via RS485 if connected to SP1 devices.

The microprocessor control installed in the unit receives operating settings from one of the following thermostats:

- HID-T2 - Electronic room control for wall installation
- HID-T3 - Electronic room control for wall installation with humidity probe

With CTSP1 electronics is provided also a return air probe for the reading of the room temperature. By default is expected that the air probe of the room thermostat (HIDT...), when present, is priority respect to the return air probe, even if it is connected. When there isn't room thermostat, the unit adjusts on its return air probe. Through the setting of a parameter it's possible that this priority can be reversed and therefore the reading of temperature by the return air probe is priority respect to the air probe of the room thermostat (HIDT...), even though this is simultaneously connected.

When it isn't present, the return air probe of the unit will adjust on the value detected by the thermostat.

Its functionalities are:

- control of minimum temperature of system water temperature
- Control of manual or automatic speed fan
- control of on/off water valve
- control card of 0-10V valve and fan through the additional card CPVM
- digital input for remote on/off function or winter/summer
- fan control / fresh air damper actuator
- on/off control of electrical heating element or cumulative alarm relay.

The serial port with MODBUS protocol. Allows the cable connection between the units and the ELFOControl or B.M.S. It allow to create mini networks (a single HIDT... thermostat that controls up to 9 units).

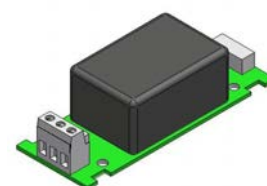
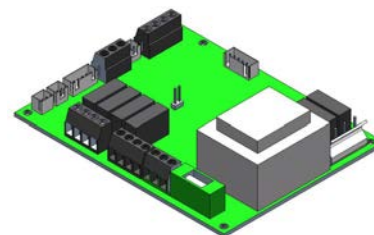

## CPVM - Control additional card of 0-10V valve and EC fan (available only with options: CTSP1)

Control card of fan and 0-10V valve.

## RE - Electric heaters

Electrical heating elements manufactured in accordance with international standards on electricity and safety, shielded with aluminium heat exchanging fins.

They are supplied complete with an automatic-reset safety thermostat and power relay

Standard: electrical heating elements installed inside the unit with electrical cables 230V/1Ph/50Hz.



Configuration suitable for all version with 2 pipe system (CC2 - 1 coil). Dual-stage heating element with possibility to connect them reducing by 1/3 the power (for example from 1,5 kW to 1 kW).

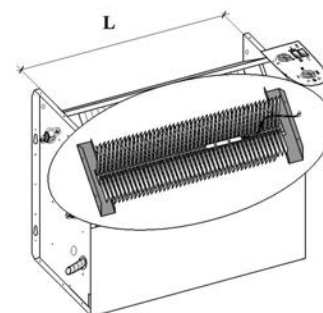

### Compatibility

Size	003.0	005.0	007.0	009.0	011.0	015.0	017.0	021.0	025.0	031.0	041.0	051.0
1 kW	X	X	-	-	-	-	-	-	-	-	-	-
1,5 kW	-	-	X	X	-	-	-	-	-	-	-	-
2 kW	-	-	-	-	X	X	-	-	-	-	-	-
3 kW	-	-	-	-	-	-	X	X	X	X	X	X

### Dimensions

Size	003.0	005.0	007.0	009.0	011.0	015.0	017.0	021.0	025.0	031.0	041.0	051.0
L (length) [mm]	400	400	600	600	800	800	1000	1000	1200	1200	1400	1400

### Electrical data

Electric heaters	F.L.A. (A)	F.L.I. (kW)
Electric heaters from 1 kW	4,35	1,00
Electric heaters from 1,5 kW	6,53	1,50
Electric heaters from 2 kW	8,70	2,00
Electric heaters from 3 kW	13,05	3,00

## 2V2 - ON/OFF 2-way valve kit for 2 pipe system

## 2V4 - ON/OFF 2 way valve kit for 4 pipe system

## 3V2 - Three-way valve kit for 2 pipe "on/off" system

## 3V4 - Three-way valve kit for 4 pipe "on/off" system

## 10V2 - 0-10V 3-way valve kit for 2 pipe system

## 10V4 - 0-10V 3 way valve kit for 4 pipe system

Valve kit complete with electro-thermal servo-control, for all versions (vertical unit with cabinet OUTV, horizontal with cabinet OUTH, vertical recessed INV and horizontal recessed INH) and for units with connections either or right or left.

Valve kit components:

2V2 = N°1 2-way valve DN 3/4" (Kv=2,5) + N°1 Actuator + Installation kit (\*)

2V4 = Cooling valve: N°1 2-way valve DN 3/4" (Kv=2,5) + N°1 Actuator + Installation kit (\*)

Heating valve: N°1 2-way valve DN 1/2" (Kv=1,7) + N°1 Actuator + Installation kit (\*)

3V2 / 10V2 = N°1 3-way valve DN 3/4" (Kv=2,5) + N°1 Actuator + Installation kit (\*)

3V4 / 10V4 = Cooling coil: N°1 3-way valve DN 3/4" (Kv=2,5) + N°1 Actuator + Installation kit (\*)

Heating coil: N°1 3-way valve DN 1/2" (Kv=1,7) + N°1 Actuator + Installation kit (\*)

(\*) The "installation kit" include all necessary components to mount the regulation valve on the unit: copper pipes kit + nipples/connections/curves/reductions kit + sealing + gaskets + electrical wiring, etc.



Accessory also available separately supplied.



Availability 90° pipe-fitting kit (KR90X). Please, for the description of the accessory, see the next section dedicated to the "ACCESSORY SEPARATELY SUPPLIED".

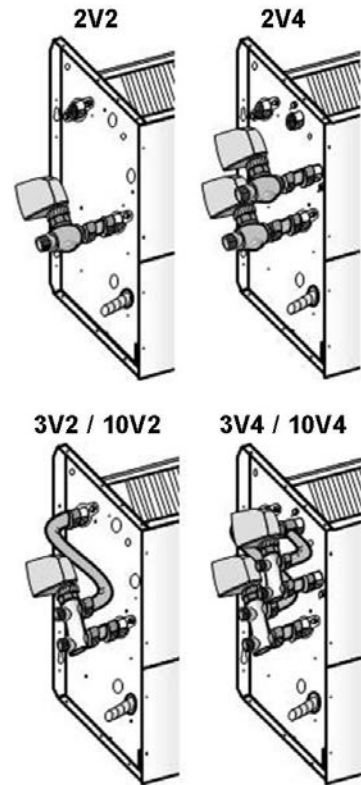

Installation	Diameter [Ø]	Kvs	ΔP max [kPa]	Kv by pass
Main coil (standard)	3/4"	2.8	70	1.8
Additional coil	1/2"	1.7	80	1.3

### Pressure drop

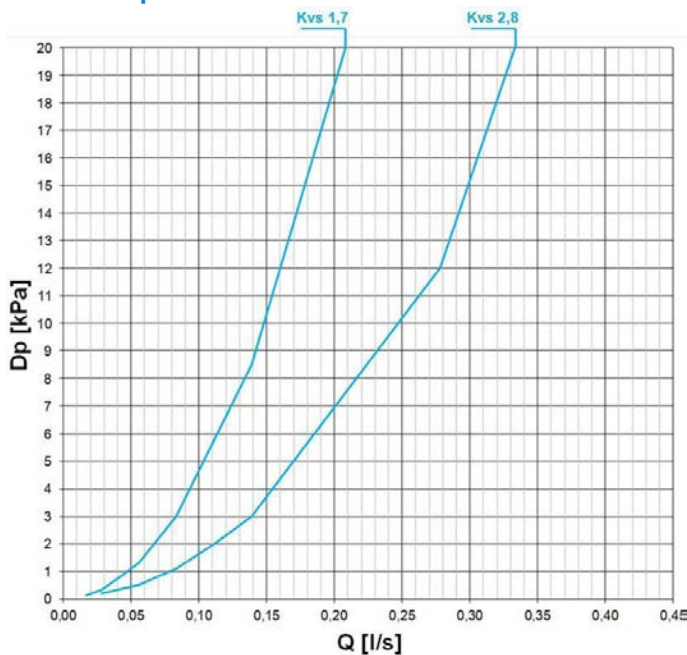

Q = Water flow rate (l/s)  
Dp = Pressure drops (kPa)

## KB12 - 2 tube water balancing kit = ball valve+water balancing kit

## KB14 - 4 tube water balancing kit = 2 ball valves+2 water balancing kit

Kit composed of shut-off (ball) valve, stopper and copper fittings suitable for all versions (vertical unit with cabinet OUTV, horizontal with cabinet OUTH, vertical recessed INV and horizontal recessed INH) and for units with connections either on right or left.

Water balancing kit	Diameter [Ø]	Kvs
Shut-off (ball) valve	1/2" F	14.6
Balancing valve	1/2" F	2.5

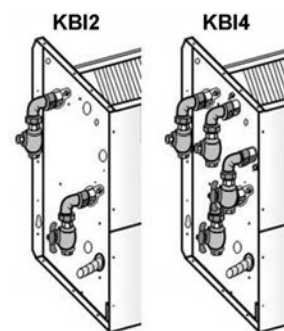

Accessories also available separately supplied.

### Balancing kit pressure drop

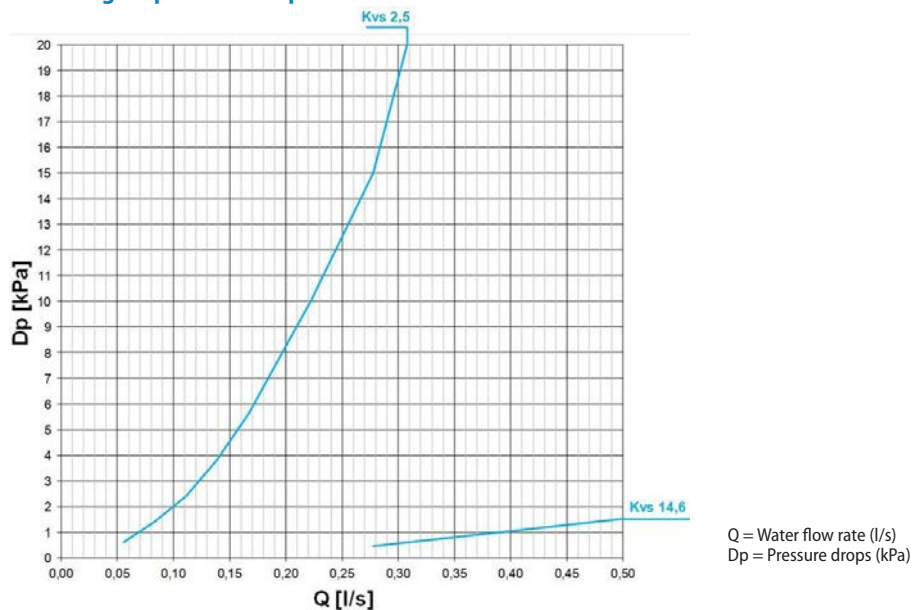

## CDP - Condensate drain pump

Condensate drain pump provided with 8A (250V) alarm contact, suitable for all vertical version (INV and OUTV) and all horizontal version (INH and OUTH).

Water flow:

- 8 l/h con 0 m.w.c. (max);
- 6,5 l/h con 1 m.w.c.;
- 4 l/h con 3 m.w.c.;
- 0 l/h con 6 m.w.c.



Accessories also available separately supplied.



## BRV - Auxiliary condensate collection pan (vertical installation)

The auxiliary drain pan for vertical version makes it possible to collect the condensation of the unit's connection tubes : It's made plastic material.

This accessory is suitable for:

- installation on all sizes
- for units with connections either on right or left.



Accessories also available separately supplied.

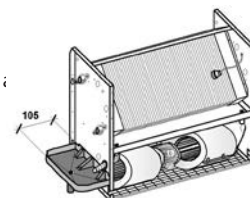

## BROP - Auxiliary drain pan (horizontal installation)

The auxiliary tub makes it possible to collect the condensation of the unit's connection tubes and valves. Made of plastic.

This accessory is suitable for:

- installation on all sizes
- for units with connections either on right or left.



Accessories also available separately supplied.

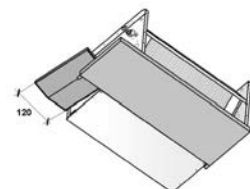

## VEC - High efficiency EC fan (available with options: TR, TRM, TRP, TRMP, CTSP1 + CPVM)

The ELFOspace series can be configured with an innovative DC Brushless motor fan of last generation with permanent magnets, Brushless, DC, equipped with the driving electronics (inverter) and ensures reduced consumption thanks to the modulation of the ventilation.

Continuous variation 0-100% of the rpm (and thus air flow and consequently the cooling/heating capacity) through the modulating control signal 0-10Vdc.

Fan section easy to remove (fixed by just 4 screws).

The extreme efficiency, also at low speed, makes possible a great reduction in electric consumption and the operating costs in comparison to a traditional fan coil with AC motor.

The main advantages are:

- Large reduction in energy consumption, thanks to an optimal response to the thermal load of the environment during every moment of the day;
- Operating silence at all rotation speeds;
- Ability to operate at any rotation speed.



Not available for size 041.0 and 051.0.



### Compare power consumption

VENS-CC2_AC fan (standard) for 2 pipe system		003.0	005.0	007.0	009.0	011.0	015.0	017.0	021.0	025.0	031.0
<b>F.L.A. Full load current at max admissible conditions</b>											
F.L.A. Total	[A]	0,25	0,25	0,4	0,4	0,35	0,35	0,65	0,65	0,77	0,77
<b>F.L.I. - Full load power input at max admissible conditions</b>											
F.L.I. Total	[kW]	0,055	0,055	0,085	0,085	0,075	0,075	0,145	0,145	0,175	0,175

VEC-CC2_High efficiency EC fan for 2 pipe system		003.0	005.0	007.0	009.0	011.0	015.0	017.0	021.0	025.0	031.0
<b>F.L.A. Full load current at max admissible conditions</b>											
F.L.A. Total	[A]	0,15	0,19	0,2	0,25	0,16	0,2	0,31	0,35	0,48	0,48
<b>F.L.I. - Full load power input at max admissible conditions</b>											
F.L.I. Total	[kW]	0,019	0,025	0,027	0,034	0,023	0,026	0,046	0,053	0,073	0,073

(1) Indoor air at 27°C D.B/19 C.W.B  
Water temperature in / out 7°C / 12°C  
Air flow at maximum speed (ESP = 0Pa)

(2) Indoor air temperature at 20°C  
Water inlet 70°C and outlet 60°C  
Air flow at maximum speed (ESP = 0Pa)

VENS-CC4_AC fan (standard) for 4 pipe system		003.0	005.0	007.0	009.0	011.0	015.0	017.0	021.0	025.0	031.0
<b>F.L.A. Full load current at max admissible conditions</b>											
F.L.A. Total	[A]	0,25	0,25	0,4	0,4	0,35	0,35	0,65	0,65	0,77	0,77
<b>F.L.I. - Full load power input at max admissible conditions</b>											
F.L.I. Total	[kW]	0,055	0,055	0,085	0,085	0,075	0,075	0,145	0,145	0,175	0,175

VEC-CC4_High efficiency EC fan for 4 pipe system		003.0	005.0	007.0	009.0	011.0	015.0	017.0	021.0	025.0	031.0
<b>F.L.A. Full load current at max admissible conditions</b>											
F.L.A. Total	[A]	0,13	0,17	0,19	0,22	0,15	0,17	0,29	0,31	0,48	0,48
<b>F.L.I. - Full load power input at max admissible conditions</b>											
F.L.I. Total	[kW]	0,016	0,023	0,026	0,03	0,022	0,023	0,042	0,046	0,073	0,073

(1) Indoor air at 27°C D.B/19 C.W.B  
Water temperature in / out 7°C / 12°C  
Air flow at maximum speed (ESP = 0Pa)

(2) Indoor air temperature at 20°C  
Water inlet 70°C and outlet 60°C  
Air flow at maximum speed (ESP = 0Pa)



## Performance correction coefficients as a function of air flow and external static pressure

### 2 pipe system - High efficiency EC fan

ESP (Pa)	Fan speed	Size														
		003.0			005.0			007.0			009.0			011.0		
		P <sub>F</sub>	P <sub>S</sub>	P <sub>T</sub>	P <sub>F</sub>	P <sub>S</sub>	P <sub>T</sub>	P <sub>F</sub>	P <sub>S</sub>	P <sub>T</sub>	P <sub>F</sub>	P <sub>S</sub>	P <sub>T</sub>	P <sub>F</sub>	P <sub>S</sub>	P <sub>T</sub>
0	Max	1,26	1,31	1,28	1,20	1,23	1,21	1,15	1,17	1,16	1,08	1,10	1,09	1,30	1,35	1,32
	Mid	1,00	1,00	1,00	1,00	1,00	1,00	1,00	1,00	1,00	1,00	1,00	1,00	1,00	1,00	1,00
	Min	0,76	0,73	0,75	0,73	0,70	0,72	0,71	0,67	0,69	0,67	0,62	0,65	0,75	0,72	0,74
10	Max	1,22	1,26	1,24	1,17	1,19	1,18	1,11	1,12	1,11	1,04	1,05	1,05	1,24	1,28	1,26
	Mid	0,97	0,97	0,97	0,97	0,97	0,97	0,96	0,96	0,96	0,96	0,96	0,96	0,96	0,95	0,95
	Min	0,74	0,71	0,73	0,71	0,67	0,70	0,68	0,64	0,66	0,64	0,60	0,62	0,72	0,68	0,71
20	Max	1,19	1,22	1,20	1,13	1,15	1,14	1,07	1,08	1,07	1,01	1,01	1,01	1,18	1,21	1,19
	Mid	0,94	0,93	0,94	0,94	0,93	0,94	0,93	0,92	0,92	0,93	0,92	0,92	0,91	0,90	0,90
	Min	0,72	0,68	0,70	0,69	0,65	0,67	0,66	0,61	0,64	0,62	0,57	0,60	0,69	0,65	0,67
30	Max	1,14	1,17	1,15	1,09	1,11	1,10	1,03	1,04	1,03	0,97	0,97	0,97	1,12	1,14	1,12
	Mid	0,91	0,90	0,90	0,91	0,90	0,90	0,90	0,88	0,89	0,90	0,88	0,89	0,86	0,84	0,85
	Min	0,69	0,66	0,68	0,66	0,62	0,65	0,63	0,59	0,62	0,60	0,55	0,58	0,65	0,61	0,63
40	Max	1,11	1,12	1,11	1,05	1,06	1,06	0,99	0,99	0,99	0,94	0,93	0,93	1,05	1,05	1,05
	Mid	0,88	0,86	0,87	0,88	0,86	0,87	0,87	0,85	0,86	0,87	0,85	0,86	0,81	0,78	0,79
	Min	0,67	0,63	0,65	0,64	0,60	0,62	0,61	0,57	0,59	0,58	0,53	0,56	0,61	0,56	0,59
50	Max	1,05	1,06	1,05	1,00	1,00	1,00	0,96	0,95	0,95	0,90	0,89	0,90	0,95	0,94	0,95
	Mid	0,83	0,81	0,82	0,83	0,81	0,82	0,83	0,81	0,82	0,83	0,81	0,82	0,73	0,70	0,72
	Min	0,64	0,59	0,62	0,61	0,56	0,59	0,59	0,54	0,57	0,55	0,51	0,53	0,55	0,50	0,53
60	Max	0,99	0,98	0,98	0,94	0,93	0,94	0,91	0,90	0,91	0,86	0,84	0,85	0,82	0,80	0,81
	Mid	0,78	0,75	0,77	0,78	0,75	0,77	0,79	0,77	0,78	0,79	0,77	0,78	0,63	0,59	0,61
	Min	0,60	0,55	0,58	0,57	0,53	0,55	0,56	0,51	0,54	0,53	0,48	0,51	0,48	0,42	0,45
70	Max	0,92	0,90	0,91	0,87	0,85	0,86	0,86	0,84	0,85	0,81	0,78	0,80	0,66	0,62	0,65
	Mid	0,73	0,69	0,71	0,73	0,69	0,71	0,75	0,71	0,73	0,75	0,71	0,73	0,44	0,39	0,42
	Min	0,56	0,51	0,54	0,53	0,48	0,51	0,53	0,48	0,51	0,50	0,45	0,48	n.d.	n.d.	n.d.
80	Max	0,83	0,80	0,82	0,79	0,76	0,78	0,78	0,75	0,77	0,73	0,70	0,72	0,50	0,45	0,48
	Mid	0,66	0,62	0,64	0,66	0,62	0,64	0,68	0,64	0,66	0,68	0,64	0,66	n.d.	n.d.	n.d.
	Min	0,50	0,45	0,48	0,48	0,43	0,46	0,48	0,43	0,46	0,45	0,40	0,43	n.d.	n.d.	n.d.
90	Max	0,66	0,62	0,64	0,63	0,58	0,61	0,64	0,60	0,62	0,61	0,56	0,59	n.d.	n.d.	n.d.
	Mid	0,51	0,46	0,49	0,52	0,47	0,50	0,55	0,50	0,53	0,56	0,51	0,54	n.d.	n.d.	n.d.
	Min	n.d.	n.d.	n.d.	n.d.	n.d.	n.d.	0,35	0,29	0,32	0,35	0,29	0,32	n.d.	n.d.	n.d.

Technical data referred to the following conditions:

Cooling: Indoor air temperature at 27°C D.B. / 19°C W.B.

Water temperature in / out 7°C / 12°C

Heating: Indoor air temperature 20°C

Water temperature in / out 70°C / 60°C

P<sub>F</sub> = Cooling capacity

P<sub>S</sub> = Sensible cooling capacity

P<sub>T</sub> = Heating capacity

The nominal performance with high efficiency EC fans (VEC) refer to the modulating signal which guarantees the nominal performance with standard AC fans (VENS).

## Performance correction coefficients as a function of air flow and external static pressure

### 2 pipe system - High efficiency EC fan

ESP (Pa)	Fan speed	Size														
		015.0			017.0			021.0			025.0			031.0		
		P <sub>F</sub>	P <sub>S</sub>	P <sub>T</sub>	P <sub>F</sub>	P <sub>S</sub>	P <sub>T</sub>	P <sub>F</sub>	P <sub>S</sub>	P <sub>T</sub>	P <sub>F</sub>	P <sub>S</sub>	P <sub>T</sub>	P <sub>F</sub>	P <sub>S</sub>	P <sub>T</sub>
0	Max	1,24	1,28	1,26	1,11	1,13	1,12	1,08	1,09	1,08	1,00	1,00	1,00	1,00	1,00	1,00
	Mid	1,00	1,00	1,00	1,00	1,00	1,00	1,00	1,00	1,00	0,87	0,85	0,86	0,87	0,85	0,86
	Min	0,72	0,68	0,71	0,66	0,62	0,65	0,64	0,60	0,62	0,59	0,54	0,57	0,59	0,54	0,57
10	Max	1,19	1,22	1,20	1,06	1,07	1,07	1,03	1,03	1,03	0,96	0,96	0,96	0,96	0,96	0,96
	Mid	0,96	0,95	0,95	0,96	0,95	0,95	0,96	0,95	0,95	0,84	0,81	0,83	0,84	0,81	0,83
	Min	0,69	0,65	0,67	0,63	0,59	0,61	0,61	0,57	0,59	0,57	0,52	0,55	0,57	0,52	0,55
20	Max	1,13	1,15	1,14	1,01	1,01	1,01	0,98	0,97	0,98	0,92	0,91	0,92	0,92	0,91	0,92
	Mid	0,91	0,90	0,90	0,91	0,89	0,90	0,91	0,89	0,90	0,80	0,78	0,79	0,80	0,78	0,79
	Min	0,66	0,61	0,64	0,60	0,55	0,58	0,58	0,54	0,56	0,54	0,49	0,52	0,54	0,49	0,52
30	Max	1,07	1,08	1,07	0,95	0,94	0,95	0,92	0,91	0,92	0,87	0,86	0,87	0,87	0,86	0,87
	Mid	0,86	0,84	0,85	0,86	0,83	0,85	0,86	0,83	0,85	0,76	0,73	0,75	0,76	0,73	0,75
	Min	0,62	0,57	0,60	0,57	0,52	0,55	0,55	0,50	0,53	0,52	0,47	0,49	0,52	0,47	0,49
40	Max	1,00	1,00	1,00	0,89	0,87	0,88	0,86	0,84	0,85	0,82	0,80	0,81	0,82	0,80	0,81
	Mid	0,81	0,78	0,79	0,80	0,77	0,79	0,80	0,77	0,79	0,72	0,68	0,70	0,72	0,68	0,70
	Min	0,58	0,53	0,56	0,53	0,48	0,51	0,51	0,46	0,49	0,49	0,43	0,46	0,49	0,43	0,46
50	Max	0,91	0,89	0,90	0,81	0,78	0,80	0,79	0,76	0,77	0,74	0,70	0,72	0,74	0,70	0,72
	Mid	0,73	0,70	0,72	0,73	0,70	0,72	0,73	0,70	0,72	0,64	0,60	0,62	0,64	0,60	0,62
	Min	0,53	0,48	0,51	0,48	0,43	0,46	0,47	0,42	0,45	0,43	0,38	0,41	0,43	0,38	0,41
60	Max	0,79	0,76	0,77	0,73	0,69	0,71	0,71	0,67	0,69	0,61	0,56	0,59	0,61	0,56	0,59
	Mid	0,63	0,59	0,61	0,66	0,61	0,64	0,66	0,61	0,64	0,53	0,48	0,51	0,53	0,48	0,51
	Min	0,46	0,40	0,43	0,43	0,38	0,41	0,42	0,37	0,40	0,36	0,31	0,34	0,36	0,31	0,34
70	Max	0,63	0,59	0,62	0,62	0,57	0,60	0,60	0,55	0,58	0,51	0,46	0,49	0,51	0,46	0,49
	Mid	0,46	0,41	0,44	0,56	0,51	0,54	0,56	0,51	0,54	0,44	0,39	0,42	0,44	0,39	0,42
	Min	n.d.	n.d.	n.d.	n.d.	n.d.	n.d.	n.d.	n.d.	n.d.	n.d.	n.d.	n.d.	n.d.	n.d.	n.d.
80	Max	0,48	0,43	0,46	0,47	0,42	0,45	0,46	0,41	0,44	0,40	0,35	0,38	0,40	0,35	0,38
	Mid	n.d.	n.d.	n.d.	0,43	0,37	0,40	0,43	0,37	0,40	n.d.	n.d.	n.d.	n.d.	n.d.	n.d.
	Min	n.d.	n.d.	n.d.	n.d.	n.d.	n.d.	n.d.	n.d.	n.d.	n.d.	n.d.	n.d.	n.d.	n.d.	n.d.
90	Max	n.d.	n.d.	n.d.	n.d.	n.d.	n.d.	n.d.	n.d.	n.d.	n.d.	n.d.	n.d.	n.d.	n.d.	n.d.
	Mid	n.d.	n.d.	n.d.	n.d.	n.d.	n.d.	n.d.	n.d.	n.d.	n.d.	n.d.	n.d.	n.d.	n.d.	n.d.
	Min	n.d.	n.d.	n.d.	n.d.	n.d.	n.d.	n.d.	n.d.	n.d.	n.d.	n.d.	n.d.	n.d.	n.d.	n.d.

Technical data referred to the following conditions:

Cooling: Indoor air temperature at 27°C D.B. / 19°C W.B.

Water temperature in / out 7°C / 12°C

Heating: Indoor air temperature 20°C

Water temperature in / out 70°C / 60°C

P<sub>F</sub> = Cooling capacity

P<sub>S</sub> = Sensible cooling capacity

P<sub>T</sub> = Heating capacity

The nominal performance with high efficiency EC fans (VEC) refer to the modulating signal which guarantees the nominal performance with standard AC fans (VENS)..

## Performance correction coefficients as a function of air flow and external static pressure

### 4 pipe system - High efficiency EC fan

ESP (Pa)	Fan speed	Size														
		003.0			005.0			007.0			009.0			011.0		
		P <sub>F</sub>	P <sub>S</sub>	P <sub>T</sub>	P <sub>F</sub>	P <sub>S</sub>	P <sub>T</sub>	P <sub>F</sub>	P <sub>S</sub>	P <sub>T</sub>	P <sub>F</sub>	P <sub>S</sub>	P <sub>T</sub>	P <sub>F</sub>	P <sub>S</sub>	P <sub>T</sub>
0	Max	1,30	1,36	1,33	1,24	1,28	1,26	1,18	1,21	1,19	1,12	1,14	1,13	1,34	1,40	1,36
	Mid	1,00	1,00	1,00	1,00	1,00	1,00	1,00	1,00	1,00	1,00	1,00	1,00	1,00	1,00	1,00
	Min	0,79	0,76	0,78	0,76	0,72	0,74	0,72	0,69	0,71	0,69	0,65	0,67	0,77	0,74	0,76
10	Max	1,27	1,31	1,29	1,20	1,24	1,22	1,13	1,16	1,14	1,08	1,09	1,08	1,28	1,33	1,30
	Mid	0,97	0,97	0,97	0,97	0,97	0,97	0,96	0,96	0,96	0,96	0,96	0,96	0,96	0,95	0,95
	Min	0,77	0,74	0,76	0,73	0,70	0,72	0,70	0,66	0,68	0,66	0,62	0,65	0,74	0,71	0,73
20	Max	1,23	1,27	1,24	1,17	1,19	1,18	1,09	1,11	1,10	1,04	1,05	1,04	1,22	1,25	1,23
	Mid	0,94	0,93	0,94	0,94	0,93	0,94	0,93	0,92	0,92	0,93	0,92	0,92	0,91	0,90	0,90
	Min	0,74	0,71	0,73	0,71	0,67	0,70	0,67	0,63	0,66	0,64	0,60	0,62	0,71	0,67	0,69
30	Max	1,19	1,22	1,20	1,13	1,15	1,13	1,06	1,07	1,06	1,01	1,01	1,01	1,15	1,17	1,16
	Mid	0,91	0,90	0,90	0,91	0,90	0,90	0,90	0,88	0,89	0,90	0,88	0,89	0,86	0,84	0,85
	Min	0,72	0,68	0,70	0,69	0,65	0,67	0,65	0,61	0,63	0,62	0,57	0,60	0,67	0,63	0,65
40	Max	1,14	1,17	1,15	1,09	1,10	1,09	1,02	1,02	1,02	0,97	0,97	0,97	1,08	1,09	1,08
	Mid	0,88	0,86	0,87	0,88	0,86	0,87	0,87	0,85	0,86	0,87	0,85	0,86	0,81	0,78	0,79
	Min	0,69	0,66	0,68	0,66	0,62	0,65	0,63	0,58	0,61	0,60	0,55	0,58	0,62	0,58	0,61
50	Max	1,09	1,10	1,09	1,03	1,04	1,03	0,98	0,98	0,98	0,93	0,92	0,93	0,98	0,97	0,98
	Mid	0,83	0,81	0,82	0,83	0,81	0,82	0,83	0,81	0,82	0,83	0,81	0,82	0,73	0,70	0,72
	Min	0,66	0,62	0,64	0,63	0,59	0,61	0,60	0,56	0,58	0,57	0,53	0,55	0,57	0,52	0,55
60	Max	1,02	1,02	1,02	0,97	0,97	0,97	0,94	0,93	0,93	0,89	0,87	0,88	0,84	0,82	0,84
	Mid	0,78	0,75	0,77	0,78	0,75	0,77	0,79	0,77	0,78	0,79	0,77	0,78	0,63	0,59	0,61
	Min	0,62	0,58	0,60	0,59	0,55	0,57	0,57	0,53	0,56	0,55	0,50	0,53	0,49	0,44	0,47
70	Max	0,95	0,94	0,94	0,97	0,97	0,97	0,88	0,86	0,87	0,84	0,81	0,83	0,68	0,64	0,67
	Mid	0,73	0,69	0,71	0,78	0,75	0,77	0,75	0,71	0,73	0,75	0,71	0,73	0,51	0,46	0,49
	Min	0,58	0,53	0,56	0,59	0,55	0,57	0,54	0,49	0,52	0,51	0,46	0,49	n.d.	n.d.	n.d.
80	Max	0,86	0,84	0,85	0,81	0,79	0,80	0,80	0,77	0,79	0,76	0,73	0,75	0,52	0,47	0,49
	Mid	0,66	0,62	0,64	0,66	0,62	0,64	0,68	0,64	0,66	0,68	0,64	0,66	n.d.	n.d.	n.d.
	Min	0,52	0,47	0,50	0,50	0,45	0,48	0,49	0,44	0,47	0,47	0,41	0,44	n.d.	n.d.	n.d.
90	Max	0,67	0,63	0,66	0,68	0,64	0,67	0,65	0,61	0,63	0,63	0,58	0,61	n.d.	n.d.	n.d.
	Mid	0,50	0,45	0,48	0,66	0,62	0,64	0,54	0,49	0,52	0,55	0,50	0,53	n.d.	n.d.	n.d.
	Min	n.d.	n.d.	n.d.	n.d.	n.d.	n.d.	0,35	0,29	0,32	0,35	0,29	0,32	n.d.	n.d.	n.d.

Technical data referred to the following conditions:

Cooling: Indoor air temperature at 27°C D.B. / 19°C W.B.

Water temperature in / out 7°C / 12°C

Heating: Indoor air temperature 20°C

Water temperature in / out 70°C / 60°C

P<sub>F</sub> = Cooling capacity

P<sub>S</sub> = Sensible cooling capacity

P<sub>T</sub> = Heating capacity

The nominal performance with high efficiency EC fans (VEC) refer to the modulating signal which guarantees the nominal performance with standard AC fans (VENS).

## Performance correction coefficients as a function of air flow and external static pressure

### 4 pipe system - High efficiency EC fan

ESP (Pa)	Fan speed	Size														
		015.0			017.0			021.0			025.0			031.0		
		P <sub>F</sub>	P <sub>S</sub>	P <sub>T</sub>	P <sub>F</sub>	P <sub>S</sub>	P <sub>T</sub>	P <sub>F</sub>	P <sub>S</sub>	P <sub>T</sub>	P <sub>F</sub>	P <sub>S</sub>	P <sub>T</sub>	P <sub>F</sub>	P <sub>S</sub>	P <sub>T</sub>
0	Max	1,29	1,34	1,31	1,14	1,16	1,15	1,11	1,13	1,12	1,00	1,00	1,00	1,00	1,00	1,00
	Mid	1,00	1,00	1,00	1,00	1,00	1,00	1,00	1,00	1,00	0,87	0,85	0,86	0,87	0,85	0,86
	Min	0,75	0,71	0,73	0,68	0,64	0,66	0,66	0,62	0,64	0,59	0,54	0,57	0,59	0,54	0,57
10	Max	1,23	1,27	1,25	1,09	1,10	1,09	1,06	1,07	1,06	0,96	0,96	0,96	0,96	0,96	0,96
	Mid	0,96	0,95	0,95	0,96	0,95	0,95	0,96	0,95	0,95	0,84	0,81	0,83	0,84	0,81	0,83
	Min	0,71	0,68	0,70	0,65	0,61	0,63	0,63	0,59	0,61	0,57	0,52	0,55	0,57	0,52	0,55
20	Max	1,17	1,20	1,18	1,03	1,04	1,03	1,01	1,01	1,01	0,92	0,91	0,92	0,92	0,91	0,92
	Mid	0,91	0,90	0,90	0,91	0,89	0,90	0,91	0,89	0,90	0,80	0,78	0,79	0,80	0,78	0,79
	Min	0,68	0,64	0,66	0,62	0,57	0,60	0,60	0,55	0,58	0,54	0,49	0,52	0,54	0,49	0,52
30	Max	1,17	1,20	1,18	0,97	0,97	0,97	0,95	0,94	0,95	0,87	0,86	0,87	0,87	0,86	0,87
	Mid	0,91	0,90	0,90	0,86	0,83	0,85	0,86	0,83	0,85	0,76	0,73	0,75	0,76	0,73	0,75
	Min	0,68	0,64	0,66	0,58	0,53	0,56	0,57	0,52	0,55	0,52	0,47	0,49	0,52	0,47	0,49
40	Max	1,04	1,04	1,04	0,91	0,90	0,90	0,89	0,87	0,88	0,82	0,80	0,81	0,82	0,80	0,81
	Mid	0,81	0,78	0,79	0,80	0,77	0,79	0,80	0,77	0,79	0,72	0,68	0,70	0,72	0,68	0,70
	Min	0,60	0,56	0,58	0,54	0,49	0,52	0,53	0,48	0,51	0,49	0,43	0,46	0,49	0,43	0,46
50	Max	0,94	0,93	0,94	0,83	0,81	0,82	0,81	0,78	0,80	0,74	0,70	0,72	0,74	0,70	0,72
	Mid	0,73	0,70	0,72	0,73	0,70	0,72	0,73	0,70	0,72	0,64	0,60	0,62	0,64	0,60	0,62
	Min	0,55	0,50	0,52	0,50	0,44	0,47	0,48	0,43	0,46	0,43	0,38	0,41	0,43	0,38	0,41
60	Max	0,81	0,79	0,80	0,75	0,71	0,73	0,73	0,69	0,71	0,61	0,56	0,59	0,61	0,56	0,59
	Mid	0,63	0,59	0,61	0,66	0,61	0,64	0,66	0,61	0,64	0,53	0,48	0,51	0,53	0,48	0,51
	Min	0,47	0,42	0,45	0,45	0,39	0,42	0,43	0,38	0,41	0,36	0,31	0,34	0,36	0,31	0,34
70	Max	0,66	0,61	0,64	0,63	0,59	0,62	0,62	0,57	0,60	0,51	0,46	0,49	0,51	0,46	0,49
	Mid	0,49	0,44	0,47	0,56	0,51	0,54	0,56	0,51	0,54	0,44	0,39	0,42	0,44	0,39	0,42
	Min	n.d.	n.d.	n.d.	n.d.	n.d.	n.d.	n.d.	n.d.	n.d.	n.d.	n.d.	n.d.	n.d.	n.d.	n.d.
80	Max	0,50	0,45	0,48	0,49	0,43	0,46	0,47	0,42	0,45	0,40	0,35	0,38	0,40	0,35	0,38
	Mid	n.d.	n.d.	n.d.	0,43	0,37	0,40	0,43	0,37	0,40	n.d.	n.d.	n.d.	n.d.	n.d.	n.d.
	Min	n.d.	n.d.	n.d.	n.d.	n.d.	n.d.	n.d.	n.d.	n.d.	n.d.	n.d.	n.d.	n.d.	n.d.	n.d.
90	Max	n.d.	n.d.	n.d.	n.d.	n.d.	n.d.	n.d.	n.d.	n.d.	n.d.	n.d.	n.d.	n.d.	n.d.	n.d.
	Mid	n.d.	n.d.	n.d.	n.d.	n.d.	n.d.	n.d.	n.d.	n.d.	n.d.	n.d.	n.d.	n.d.	n.d.	n.d.
	Min	n.d.	n.d.	n.d.	n.d.	n.d.	n.d.	n.d.	n.d.	n.d.	n.d.	n.d.	n.d.	n.d.	n.d.	n.d.

Technical data referred to the following conditions:

Cooling: Indoor air temperature at 27°C D.B. / 19°C W.B.

Water temperature in / out 7°C / 12°C

Heating: Indoor air temperature 20°C

Water temperature in / out 70°C / 60°C

P<sub>F</sub> = Cooling capacity

P<sub>S</sub> = Sensible cooling capacity

P<sub>T</sub> = Heating capacity

The nominal performance with high efficiency EC fans (VEC) refer to the modulating signal which guarantees the nominal performance with standard AC fans (VENS)..

## Accessories separately supplied

### HIDE2X - Remote control with E/I + 3V + on/off for wall installation

HID-E2 electromechanical room thermostat for wall installation

It allows:

- setting the desired temperature (10-30°C)
- selection of the 3 speeds (MIN - MID - MAX)
- ON/OFF
- manual Summer / Winter change
- continuous or thermostat-based ventilation
- control of on/off water valve

It can be connected to the remote air probe (PTABX, separately supplied).

The hot water minimum temperature clickson (TMX, separately supplied) can be connected.

Dimensions: 184 x 82 x 27mm

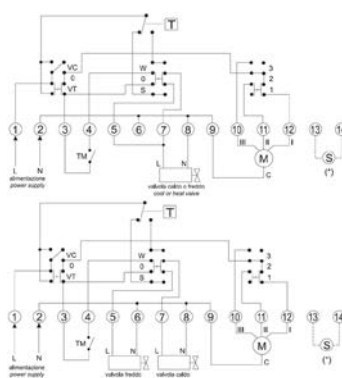

### HIDE3X - Plurifunctional remote control for wall installation

HID-E3 electromechanical room thermostat for wall installation

It allows:

- automatic fan speed adjustment (MIN - MID - MAX)
- silent operation (minimum fan speed)
- ON/OFF
- ambient temperature adjustment via the control knob: the knob's central position corresponds to the comfort condition (20°C in heating mode, 24°C in cooling mode). The temperature can be changed by +/- 5°C in relation to the comfort condition by turning the knob
- automatic selection of the Summer/Winter season: the heating or cooling mode is selected automatically by detecting the water temperature supplied to the fan-coil (water temperature below 17°C = operation in cooling mode, water temperature above 21°C = operation in heating mode)
- Hot Start function: in heating mode the fan does not start until the thermal coil is not hot enough
- control of on/off water valve
- destratification cycle
- control of electric heaters
- dirty filter warning
- minimum water temperature probe (TMX, separately supplied)

Dimensions: 184 x 82 x 27mm

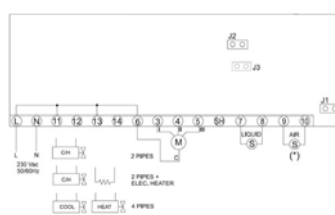

### HIDE4X - Plurifunctional room control for 0-10V valves

Electromechanical room thermostat HID-E4 for wall mounting with proportional outlets for 2 or 4 pipe systems

It allows:

- power supply 24V
- setting the desired temperature (10-30°C)
- manual Summer / Winter change
- fan speed selection (MIN - MID - MAX)
- control 0-10V coil valves for hot/cold water for thermostat-controlled 2 or 4 pipe systems with adjustable working range and neutral zone (respectively 1-5°C and 1-4°C)

Set up for connection of remote air probe (PTABX).

Dimensions: 184 x 82 x 27mm

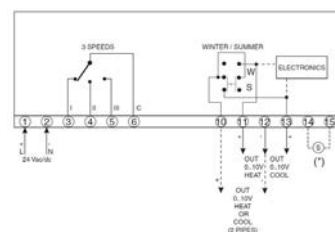

### TMX - Hot water min. temperature thermostat

The minimum water temperature clickson stops ventilation in winter mode when the water temperature of the unit is less than 40°, thus preventing air that is not particularly warm from being placed in the room. Also applicable to wall thermostats HIDE2, HIDE3 and HIDE4.

## HIDT2X - HID-T2 electronic room control

The HID-T2 room thermostat makes it possible to interface with the control module of units equipped with CLIVET TALK TERMINAL SPACE electronics (CTSP1) and to manage one or more thermostat units.

The room thermostat allows the following functions:

- setting of the desired temperature
- selection of the 3 speeds (MIN - MID - MAX) either manually or automatically
- ON / OFF
- change Summer/Winter automatically, manually or remote with digital input
- select operation in economy mode
- set the unit's operating parameters
- setting of ventilation-only mode
- control of external air shutter and control of motorized air outlet grille
- management of diagnostics with specific code for type of error

Dimensions: 123 x 86 x 27mm

The thermostat is connected to the unit via a shielded twisted pair at a maximum distance of 15 m



## HIDT3X - HID-T3 electronic room control

The HID-T3 room thermostat makes it possible to interface with the control module of units equipped with CLIVET TALK TERMINAL SPACE electronics (CTSP1) and to manage one or more thermostat units.

The room thermostat allows the following functions:

- setting of the desired temperature
- selection of the 3 speeds (MIN - MID - MAX) either manually or automatically
- ON / OFF
- change Summer/Winter automatically, manually or remote with digital input
- select operation in economy mode
- set the unit's operating parameters
- setting of ventilation-only mode
- control of external air shutter and control of motorized air outlet grille
- humidity probe management
- humidity display
- management of diagnostics with specific code for type of error

Dimensions: 123 x 86 x 27mm

The thermostat is connected to the unit via a shielded twisted pair at a maximum distance of 15 m



## HIDI8X - HID-TI8X electronic room control for 3-speed or 0-10V fan and on/off or 0-10V valve

This digital controller is intended for temperature regulation in environments equipped with fan-coil heat-cool exchangers. It controls in continuous proportional fashion the speed of high efficiency EC fan (VEC), in order to adjust the room temperature in the most suitable way. Equipped with LCD display, pre-programmable, configurable to meet the requirements of different installations. Multi-functions, with remote room air temperature sensor, for the full control of 2-4 pipes unit, with or without valves.

The HIDI8X allows the following functions:

- digital thermostat settable with manual or automatic selection of the 3 fan speeds
- manual, automatic or centralized summer/winter selection by an input, neutral zone and changeover on the supply water
- temperature control system on valves, fan or both
- LCD display with all functions displayed
- driving of On/Off valves, PWM, 3-point servo-control, 0-10V actuators, heaters, heat pumps
- special functions: economy, dirty filter warning, window contact or presence
- set-up for external and supply probe
- driving of the fan motor by 3 relays or proportional by 0-10V signal
- possibility to drive the fan motor at 230V~, the thermostat and the actuators at 24V~.



## DCPX - Control device for more units with a single room control

Control device from single thermostat for max. 4 units compatible with HID-E electromechanical thermostats. (Order 1 device every 4 units)

DIN rail mounting

Dimensions: 104 X 90 X 70 mm



## PTABX - Remote probe for room air temperature for electromechanical thermostats.

Sensors and thermostats should be located in the reference rooms, in a position enabling the actual measurement of the temperature, without any external factors influence.

Best technical solution to measure the correctly room temperature is to install the sensor in the room, on the wall of the same.

The remote room air sensor can be connected to the HID-E\_ room thermostats complete with sensor input and is 1m long.

## KR90X - 90° pipe-fitting kit

Units for 2 pipe system (CC2): kit composed of 2 copper pipes 90° valve /system kit (flanged; easy to remove).

Units for 4 pipe system (CC4): kit composed of 4 copper pipes 90° valve /system kit (flanged; easy to remove).

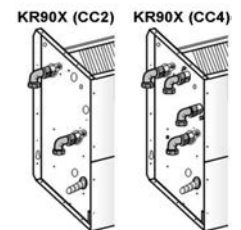

## PI90X - Support feet for built-in vertical units h=90mm

## PI155X - Support plinth for concealed vertical units h=155mm

Low (h=90mm) and high (h=155mm) couple of galvanized plinths suitable for concealed versions (without cabinet).

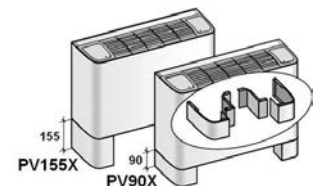

## PV90X - Support plinth with cover for in-view vertical units h=90mm

## PV155X - Support plinth with cover for in-view vertical units h=155mm

Low (h=90mm) and high (h=155mm) couple of galvanized plinths with pre-painted cover suitable for in-view versions (with cabinet).

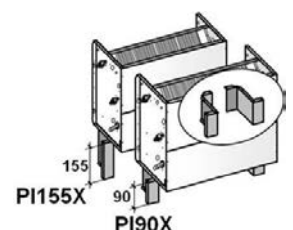

## PVG155X - Support feet with cover h=155mm and return grille

Realized in pre-painted plate with total closing of the under mobile. Complete of intake grille in ABS removable to allow the air filter cleaning. Suitable for in-view vertical versions (with cabinet).

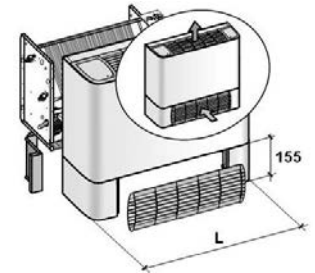

PVG155X		003.0	005.0	007.0	009.0	011.0	015.0	017.0	021.0	025.0	031.0	041.0	051.0
L (length)	[mm]	670	670	870	870	1070	1070	1270	1270	1470	1470	1670	1670

## FTZX - Galvanized steel plate falseframe

False frame in galvanized steel, recommended for rapid creation of a niche with the correct dimensions.

Required for fast installation of the unit (also equipped with accessory PR90MX: 90° air outlet plenum) and of the PNAX covering panel.

The dimensions of the niche are: L x 620 x 235

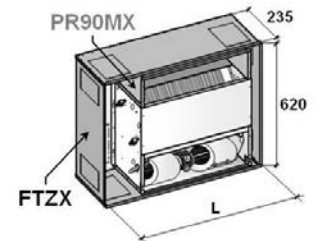

FTZX		003.0	005.0	007.0	009.0	011.0	015.0	017.0	021.0	025.0	031.0	041.0	051.0
L (length)	[mm]	650	650	850	850	1050	1050	1250	1250	1450	1450	1650	1650

## PNAX - Pre-painted panel with supply and return grilles

Panels in pre-painted sheet metal, suitable for installation on vertical recessed version (INV) or on horizontal recessed version (INH).

The panel is attached directly to the recessed unit. Therefore, no frame or wall support is required (for installation the FTZX false frame is NOT required but is recommended).

You only need to provide a niche with exactly the right dimensions.

The panel can easily be removed and can rotate 180°, allowing air flow in two different directions. It also allows easy access for filter cleaning.

The panel can easily be removed and can rotate 180°, allowing air flow in two different directions. It also allows easy access for filter cleaning.

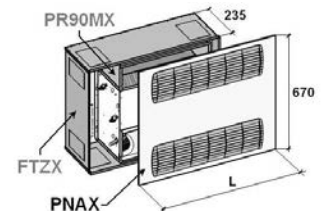

Installation of the panel requires the accessory PR90MX = 90° air outlet plenum.

PNAX		003.0	005.0	007.0	009.0	011.0	015.0	017.0	021.0	025.0	031.0	041.0	051.0
L (length)	[mm]	700	700	900	900	1100	1100	1300	1300	1500	1500	1700	1700

## PPVX - Rear cover panel for OUTV without support feet

Lower closing back panel made of pre-painted steel without support feet.

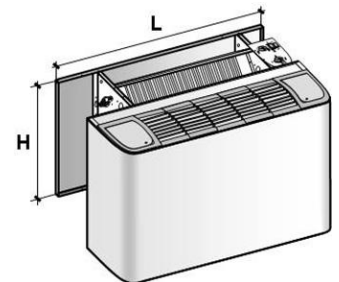

PPVX		003.0	005.0	007.0	009.0	011.0	015.0	017.0	021.0	025.0	031.0	041.0	051.0
L (length)	[mm]	640	640	840	840	1040	1040	1240	1240	1440	1440	1640	1640
H (Height)	[mm]	450	450	450	450	450	450	450	450	450	450	450	450



## PPV90X - Rear cover panel for OUTV with support feet h=90mm

Central closing back panel made of pre-painted steel suitable for in-view unit version with PV90X = support plinth with cover for in-view verticals units h=90mm.

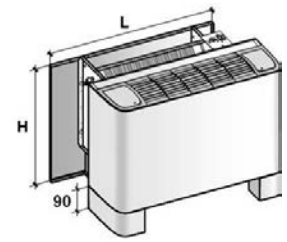

PPV90X		003.0	005.0	007.0	009.0	011.0	015.0	017.0	021.0	025.0	031.0	041.0	051.0
L (length)	[mm]	640	640	840	840	1040	1040	1240	1240	1440	1440	1640	1640
H (Height)	[mm]	540	540	540	540	540	540	540	540	540	540	540	540

## PPV155X - Rear cover panel for OUTV with support feet h=155mm

Higher closing back panel made of pre-painted steel suitable for in-view unit version with PV155X = support plinth with cover for in-view verticals units h=155mm or PVG155X = support feet with cover h=155mm and return grille.

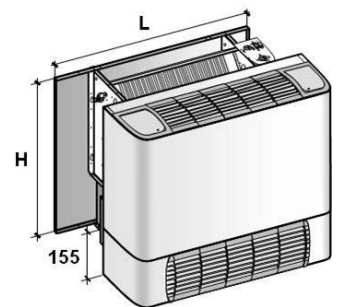

PPV155X		003.0	005.0	007.0	009.0	011.0	015.0	017.0	021.0	025.0	031.0	041.0	051.0
L (length)	[mm]	640	640	840	840	1040	1040	1240	1240	1440	1440	1640	1640
H (Height)	[mm]	610	610	610	610	610	610	610	610	610	610	610	610

## SERX - Manual outside air damper for vertical and horizontal instal

### SERMX - Outdoor air motorized on/off damper

Air damper made in galvanized steel, installed at the base of the unit at the intake, lets a certain amount of fresh air into the environment, which is controlled manually (adjustable opening), or with motorized ON/OFF command (230/1/50).

The damper can be used on both the vertical and horizontal units.

For in-view units is necessary the PV155X accessory (support plinth with cover for in-view verticals units h=155mm), but in this case the middle part of the damper will be visible, or else the PVG155X accessory (support feet with cover h=155mm and return grille) able to cover/hide totally damper.

Air damper closed: External air flow = 0% - Internal air flow = 100%

Air damper totally open: External air flow = 33% - Internal air flow = 67%

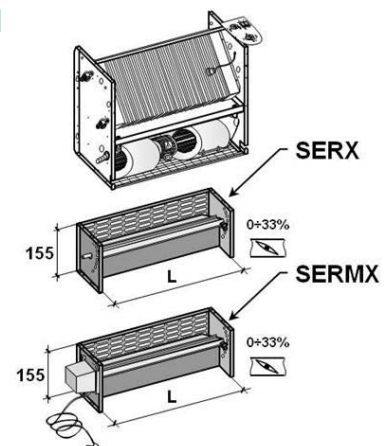

SERX - SERMX		003.0	005.0	007.0	009.0	011.0	015.0	017.0	021.0	025.0	031.0	041.0	051.0
L (length)	[mm]	400	400	600	600	800	800	1000	1000	1200	1200	1400	1400

## PRMX - Air discharge plenum

## PRAX - Air intake straight plenum

Air supply and intake straight plenum for all concealed units INV and INH.

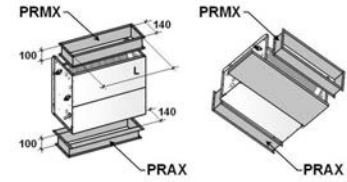

PRMX - PRAX		003.0	005.0	007.0	009.0	011.0	015.0	017.0	021.0	025.0	031.0	041.0	051.0
L (length)	[mm]	400	400	600	600	800	800	1000	1000	1200	1200	1400	1400

## PRTX - 0-100 mm telescopic extension

Telescopic extension 0-100 mm, suitable for connection onto PRMX (air discharge plenum), PRAX (air intake straight plenum), PR90MX (90° air outlet plenum), PR90AX (90° air intake plenum) in galvanized plate.

Is used to convey the air of the concealed units.

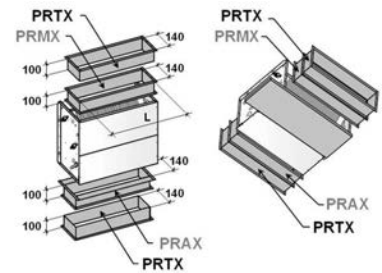

PRTX		003.0	005.0	007.0	009.0	011.0	015.0	017.0	021.0	025.0	031.0	041.0	051.0
L (length)	[mm]	400	400	600	600	800	800	1000	1000	1200	1200	1400	1400

## PRCMX - Air outlet plenum with circular fittings+internal thermal and acoustic insulation

## PRCAX - Air intake plenum with circular fittings and air filter

Air outlet insulated plenum in galvanized steel with variable diameter spigots (PRCMX) and air intake plenum in galvanized steel with variable diameter spigots with filter (PRCAX).

Spigots diameter = Ø 200/180/160mm.

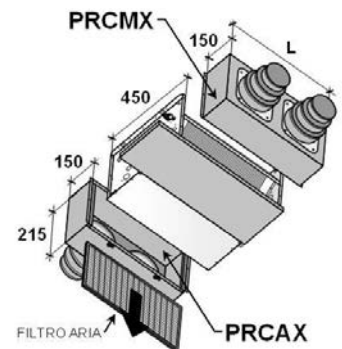

PRCMX - PRCAX		003.0	005.0	007.0	009.0	011.0	015.0	017.0	021.0	025.0	031.0	041.0	051.0
L (length)	[mm]	400	400	600	600	800	800	1000	1000	1200	1200	1400	1400
N° spigots	[n]	1	1	2	2	2	2	3	3	4	4	4	4

## PRCTX - Terminal plenum with circular connections

Terminal plenum with circular spigots to be connected (through flexible circular pipes) to the plenum PRCMX and PRCAX.

Spigots diameter = Ø 200/180/160mm.

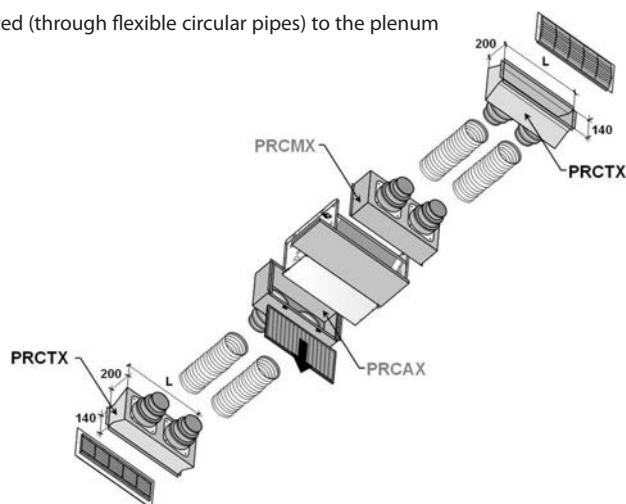

PRCTX		003.0	005.0	007.0	009.0	011.0	015.0	017.0	021.0	025.0	031.0	041.0	051.0
L (length)	[mm]	400	400	600	600	800	800	1000	1000	1200	1200	1400	1400
N° spigots	[n]	1	1	2	2	2	2	3	3	4	4	4	4

## GRMX - Air outlet grille without air filter

Air outlet grille without filter suitable for connection on PRMX (air discharge plenum), PRAX (air intake straight plenum), PR90MX (90° air outlet plenum), PR90AX (90° air intake plenum), PRTX (0-100 mm telescopic extension) with outer frame in sheet metal painted white (RAL 9010) + internal grille with fixed fins made up of grey ABS (RAL 7035).

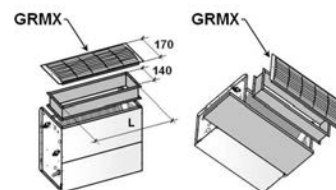

GRMX		003.0	005.0	007.0	009.0	011.0	015.0	017.0	021.0	025.0	031.0	041.0	051.0
L (length)	[mm]	400	400	600	600	800	800	1000	1000	1200	1200	1400	1400

## GRAX - Return grille with filter

Air suction grille with air filter (suitable for the connection on any plenum) with external pre-painted metal plate frame (RAL9010) + internal grille with fixed fins made up of grey ABS (RAL7035).

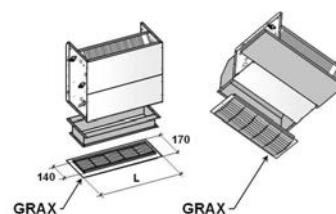

GRAX		003.0	005.0	007.0	009.0	011.0	015.0	017.0	021.0	025.0	031.0	041.0	051.0
L (length)	[mm]	400	400	600	600	800	800	1000	1000	1200	1200	1400	1400

## AGRMX - Air outlet grille in aluminium without filter

Aluminium air grill with double bank adjustable louvers, suitable to be connected to all PRMX, PRAX, PR90MX, PR90AX, PRTX plenums.

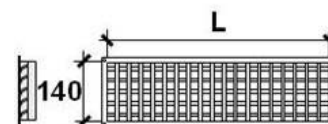

AGRMX		003.0	005.0	007.0	009.0	011.0	015.0	017.0	021.0	025.0	031.0	041.0	051.0
L (length)	[mm]	400	400	600	600	800	800	1000	1000	1200	1200	1400	1400

## AGRAX - Air intake grille with air filter

Aluminium air grill with single bank fixed louvers, suitable to be connected to all PRMX, PRAX, PR90MX, PR90AX, PRTX plenums.

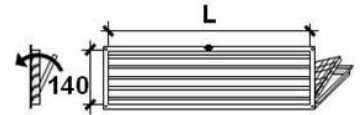

AGRAX		003.0	005.0	007.0	009.0	011.0	015.0	017.0	021.0	025.0	031.0	041.0	051.0
L (length)	[mm]	400	400	600	600	800	800	1000	1000	1200	1200	1400	1400

## PR90MX - 90° air outlet plenum

## PR90AX - 90° air intake plenum

Air outlet and intake plenum to launch air at 90°.

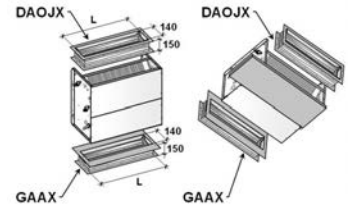

PR90MX - PR90AX		003.0	005.0	007.0	009.0	011.0	015.0	017.0	021.0	025.0	031.0	041.0	051.0
L (length)	[mm]	400	400	600	600	800	800	1000	1000	1200	1200	1400	1400

## DAOJX - Air supply duct with flexible connection

## GAAX - Air intake duct with flexible joint

The air ducts with flexible hoses may be especially suited for simplifying the coupling of the unit with the fixed ducts or with grilles.

DAOJX - GAAX		003.0	005.0	007.0	009.0	011.0	015.0	017.0	021.0	025.0	031.0	041.0	051.0
L (length)	[mm]	400	400	600	600	800	800	1000	1000	1200	1200	1400	1400

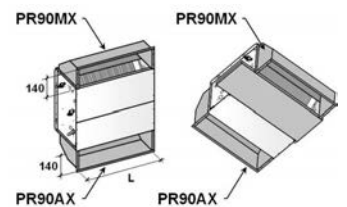

# Dimensional drawings

## ELFOSpace INV - Vertical uncased version

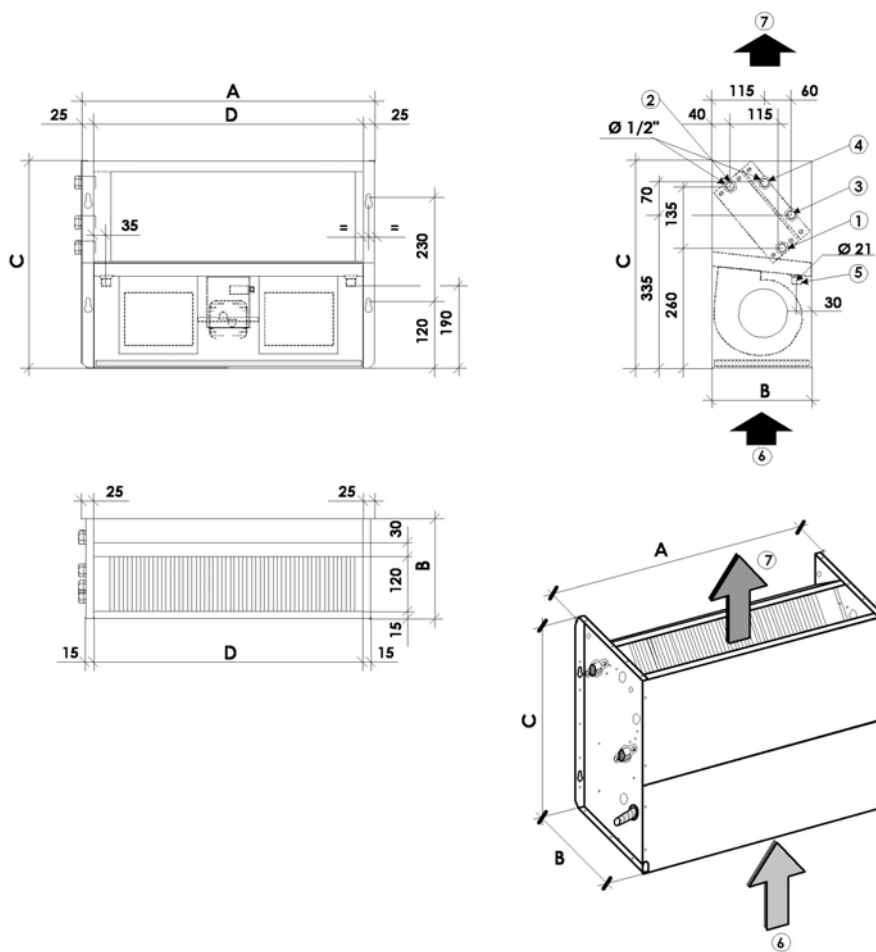

1. Water inlet (standard unit)
2. Water outlet (standard unit)
3. Additional coil water inlet (4 pipe-installation)
4. Additional coil water outlet (4 pipe- installation)
5. Condensate drain
6. Air flow - Standard air inlet
7. Air flow - Standard supply

Size		ELFOSpace INV											
		003.0	005.0	007.0	009.0	011.0	015.0	017.0	021.0	025.0	031.0	041.0	051.0
A	[mm]	450	450	650	650	850	850	1050	1050	1250	1250	1450	1450
B	[mm]	215	215	215	215	215	215	215	215	215	215	215	215
C	[mm]	450	450	450	450	450	450	450	450	450	450	450	450
D	[mm]	400	400	600	600	800	800	1000	1000	1200	1200	1400	1400
Lenght (nominal)	[mm]	450	450	650	650	850	850	1050	1050	1250	1250	1450	1450
Depth (nominal)	[mm]	215	215	215	215	215	215	215	215	215	215	215	215
Height (nominal)	[mm]	450	450	450	450	450	450	450	450	450	450	450	450
Operating weight - 2 pipe system (CC2)	[kg]	11	11	14	14	20	20	23	24	27	28	31	34
Operating weight - 4 pipe system (CC4)	[kg]	12	12	14	15	21	22	24	26	28	30	32	36



Duct nesting connection: Air supply outlet = male; Air intake suction = female.

# Dimensional drawings

## ELFOSpace OUTV - Vertical cased version

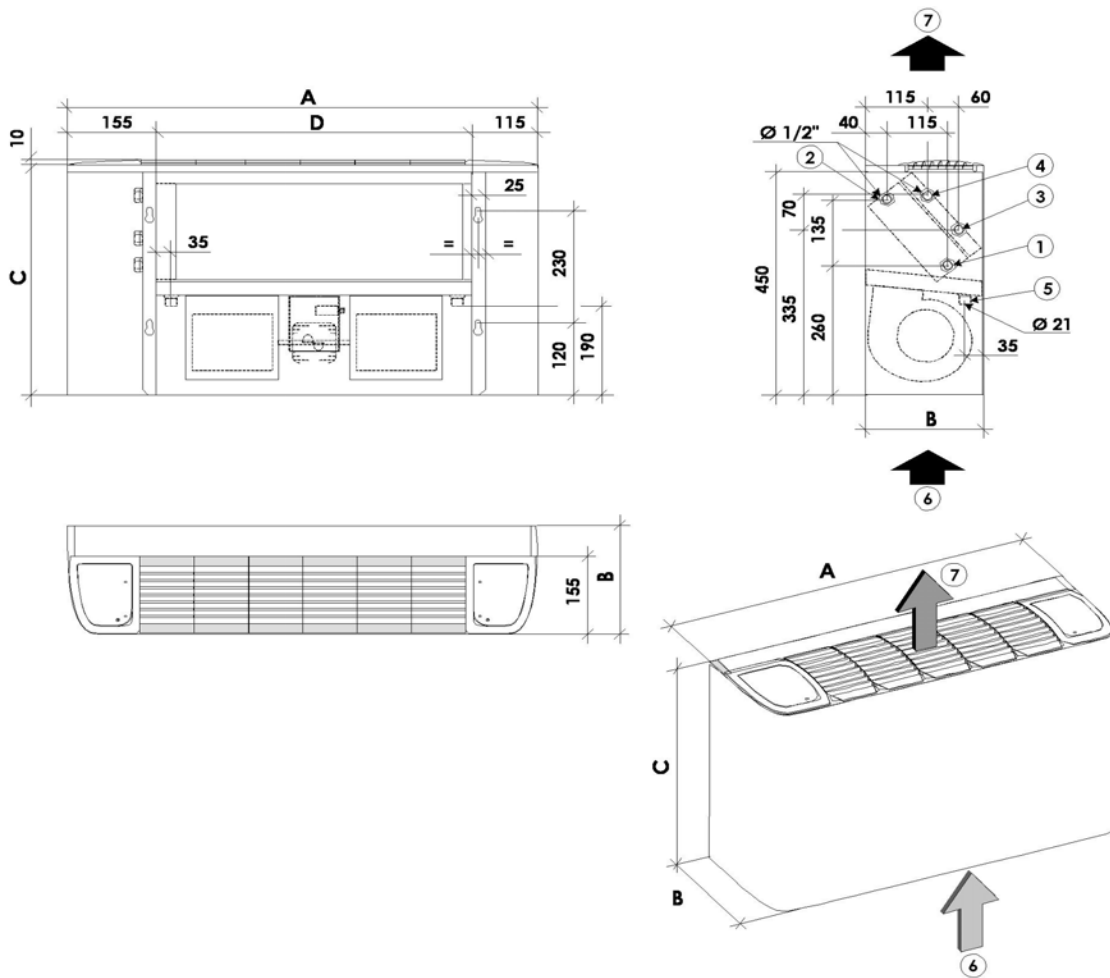

- 1. Water inlet (standard unit)
- 2. Water outlet (standard unit)
- 3. Additional coil water inlet (4 pipe-installation)
- 4. Additional coil water outlet (4 pipe- installation)
- 5. Condensate drain
- 6. Air flow - Standard air inlet
- 7. Air flow - Standard supply

		ELFOSpace OUTV											
Size		003.0	005.0	007.0	009.0	011.0	015.0	017.0	021.0	025.0	031.0	041.0	051.0
A	[mm]	670	670	870	870	1070	1070	1270	1270	1470	1470	1670	1670
B	[mm]	220	220	220	220	220	220	220	220	220	220	220	220
C	[mm]	470	470	470	470	470	470	470	470	470	470	470	470
D	[mm]	400	400	600	600	800	800	1000	1000	1200	1200	1400	1400
Lenght (nominal)	[mm]	670	670	870	870	1070	1070	1270	1270	1470	1470	1670	1670
Depth (nominal)	[mm]	220	220	220	220	220	220	220	220	220	220	220	220
Height (nominal)	[mm]	470	470	470	470	470	470	470	470	470	470	470	470
Operating weight - 2 pipe system (CC2)	[kg]	14	14	16	17	22	24	26	28	30	32	34	38
Operating weight - 4 pipe system (CC4)	[kg]	14	15	17	18	24	25	27	29	31	33	35	39



Duct nesting connection: Air supply outlet = male; Air intake suction = female.

# Dimensional drawings

## ELFOSpace OUTH - Horizontal cased version

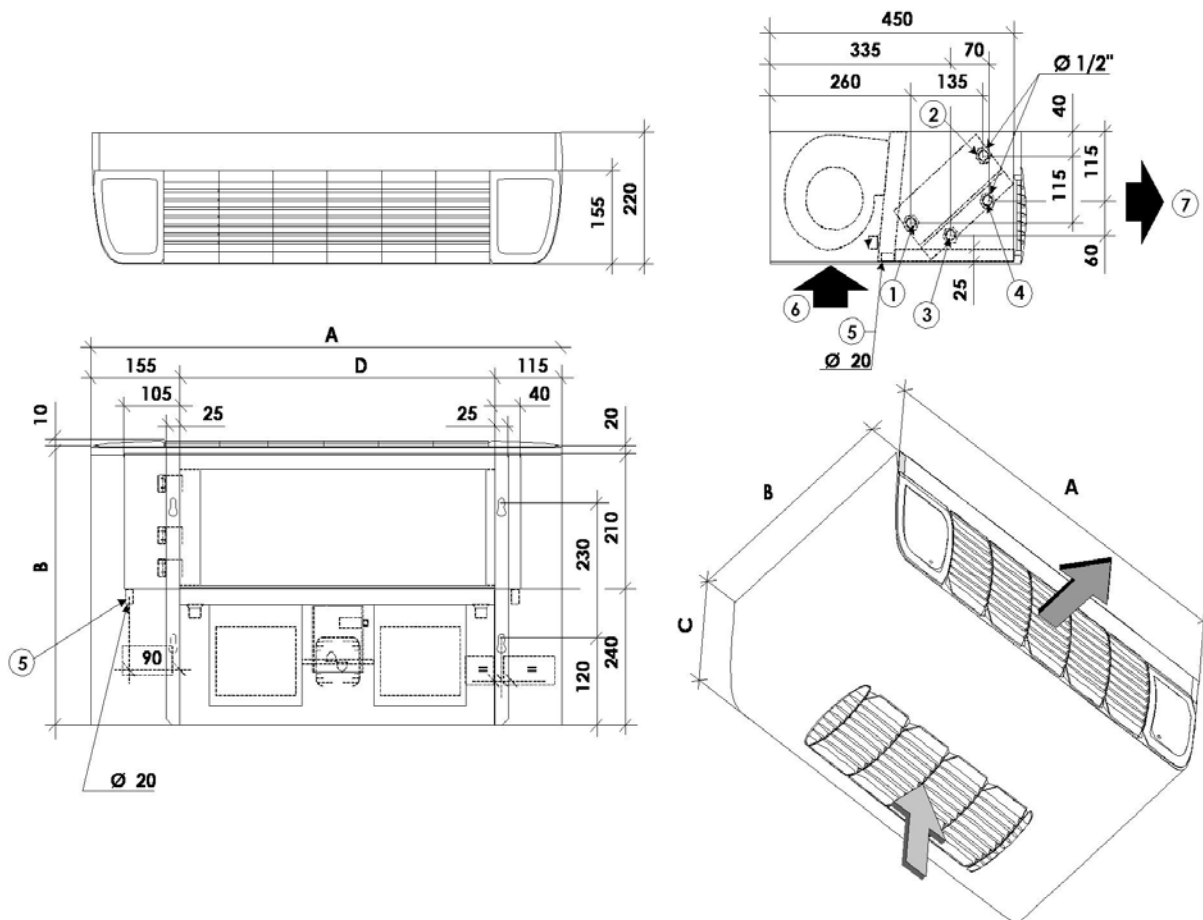

- 1. Water inlet (standard unit)
- 2. Water outlet (standard unit)
- 3. Additional coil water inlet (4 pipe-installation)
- 4. Additional coil water outlet (4 pipe- installation)
- 5. Condensate drain
- 6. Air flow - Standard air inlet
- 7. Air flow - Standard supply

Size		ELFOSpace OUTH											
		003.0	005.0	007.0	009.0	011.0	015.0	017.0	021.0	025.0	031.0	041.0	051.0
A	[mm]	670	670	870	870	1070	1070	1270	1270	1470	1470	1670	1670
B	[mm]	470	470	470	470	470	470	470	470	470	470	470	470
C	[mm]	220	220	220	220	220	220	220	220	220	220	220	220
D	[mm]	400	400	600	600	800	800	1000	1000	1200	1200	1400	1400
Lenght (nominal)	[mm]	670	670	870	870	1070	1070	1270	1270	1470	1470	1670	1670
Depth (nominal)	[mm]	470	470	470	470	470	470	470	470	470	470	470	470
Height (nominal)	[mm]	220	220	220	220	220	220	220	220	220	220	220	220
Operating weight - 2 pipe system (CC2)	[kg]	15	15	18	19	24	26	28	30	33	34	37	41
Operating weight - 4 pipe system (CC4)	[kg]	16	16	19	20	26	27	30	31	34	36	39	42



Duct nesting connection: Air supply outlet = male; Air intake suction = female.

# Dimensional drawings

## ELFOSpace INH - Horizontal uncased version

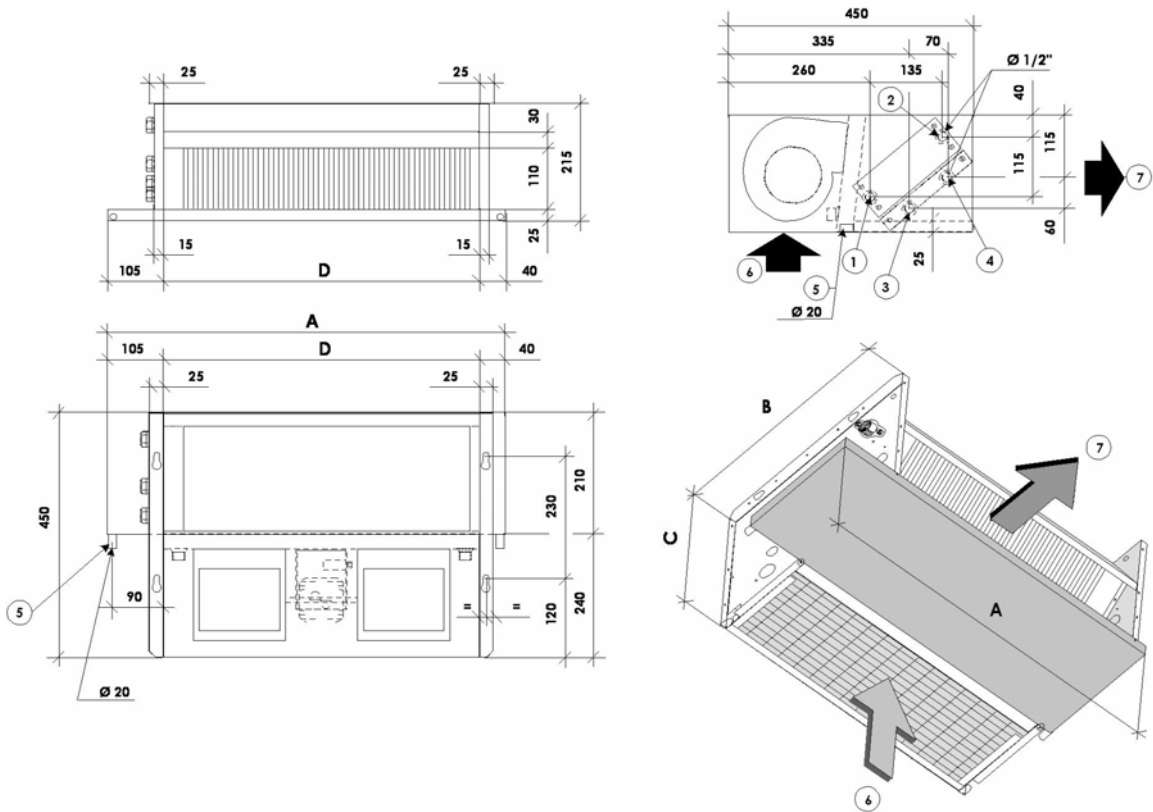

- 1. Water inlet (standard unit)
- 2. Water outlet (standard unit)
- 3. Additional coil water inlet (4 pipe-installation)
- 4. Additional coil water outlet (4 pipe- installation)
- 5. Condensate drain
- 6. Air flow - Standard air inlet
- 7. Air flow - Standard supply

Size		ELFOSpace INH											
		003.0	005.0	007.0	009.0	011.0	015.0	017.0	021.0	025.0	031.0	041.0	051.0
A	[mm]	545	545	745	745	945	945	1145	1145	1345	1345	1545	1545
B	[mm]	450	450	450	450	450	450	450	450	450	450	450	450
C	[mm]	215	215	215	215	215	215	215	215	215	215	215	215
D	[mm]	400	400	600	600	800	800	1000	1000	1200	1200	1400	1400
Lenght (nominal)	[mm]	545	545	745	745	945	945	1145	1145	1345	1345	1545	1545
Depth (nominal)	[mm]	450	450	450	450	450	450	450	450	450	450	450	450
Height (nominal)	[mm]	215	215	215	215	215	215	215	215	215	215	215	215
Operating weight - 2 pipe system (CC2)	[kg]	11	12	14	15	20	21	23	25	27	29	31	35
Operating weight - 4 pipe system (CC4)	[kg]	12	12	15	16	21	22	24	26	28	30	32	36

Duct nesting connection: Air supply outlet = male; Air intake suction = female.



## Functional clearances

For concealed versions (INV and INH):

The installer must ensure that they are masked with appropriate panels (false ceilings, false walls, cover panels, etc.), which must also provide fixed protection. The protective panels must be secured using systems that require tools to open (e.g. screws), so as to prevent the user from accessing the dangerous parts, (98/37/CEE) such as sharp edges and corners, electrical parts, moving fans, etc. The panels must be designed to be removed (using tools!) to ensure complete access to the unit, to avoid breaking or damaging structures and the masking (plasterboard, false ceilings, etc.) when special maintenance and/or replacement of the unit is required.

The measures are referred to min. distances except possible notes reported below the image

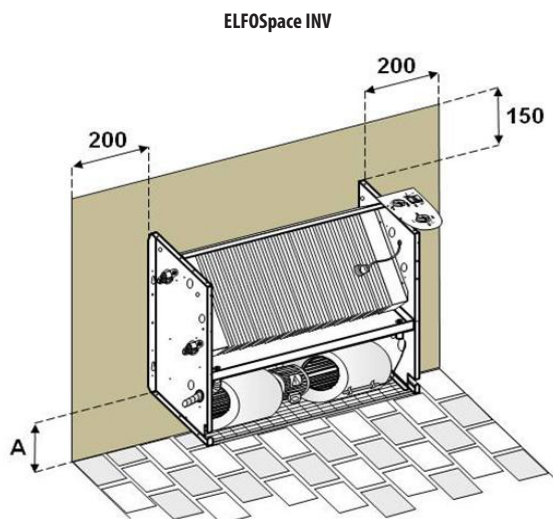

- A: - 90 mm (standard)  
 - 90 mm with plinth height = 90mm (PI90X)  
 - 155 mm with plinth height = 155mm (PI155X)

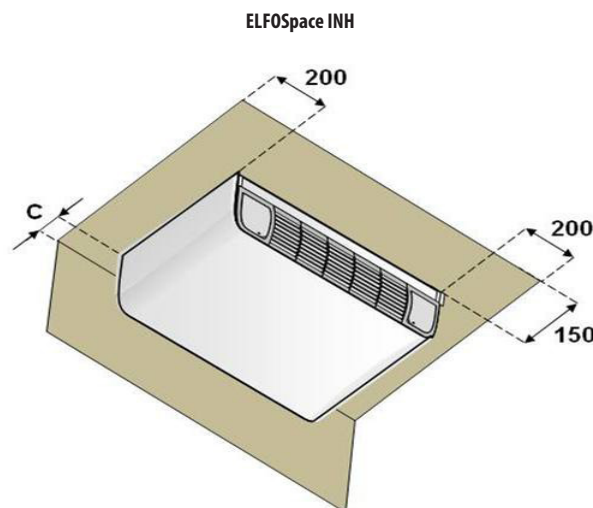

- C: - MIN 90 mm for installation with rear intake (RP)  
 - MIN 10 mm for installation with floor air inlet (R3)

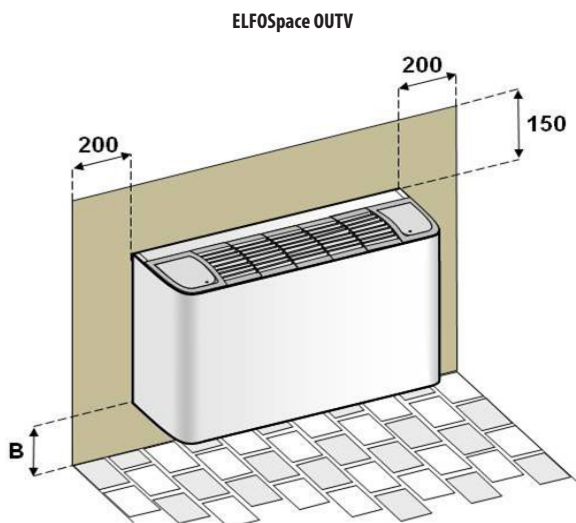

- B: - 90 mm (standard)  
 - 90 mm with plinth height = 90mm (PI90X)  
 - 155 mm with plinth height = 155mm (PI155X)

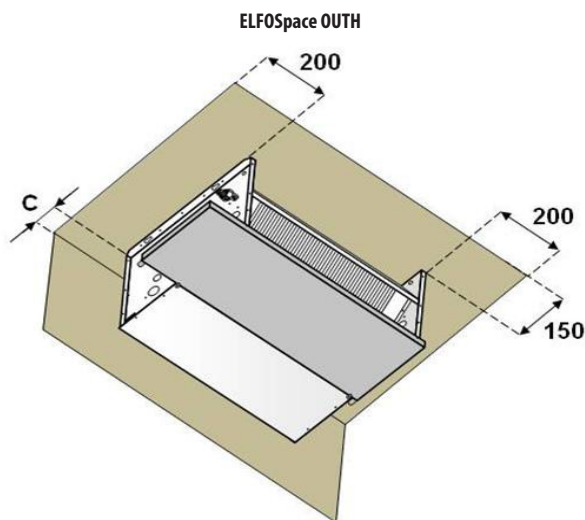

- C: - MIN 90 mm for installation with rear intake (RP)  
 - MIN 10 mm for installation with floor air inlet (R3)

# Air exhaust

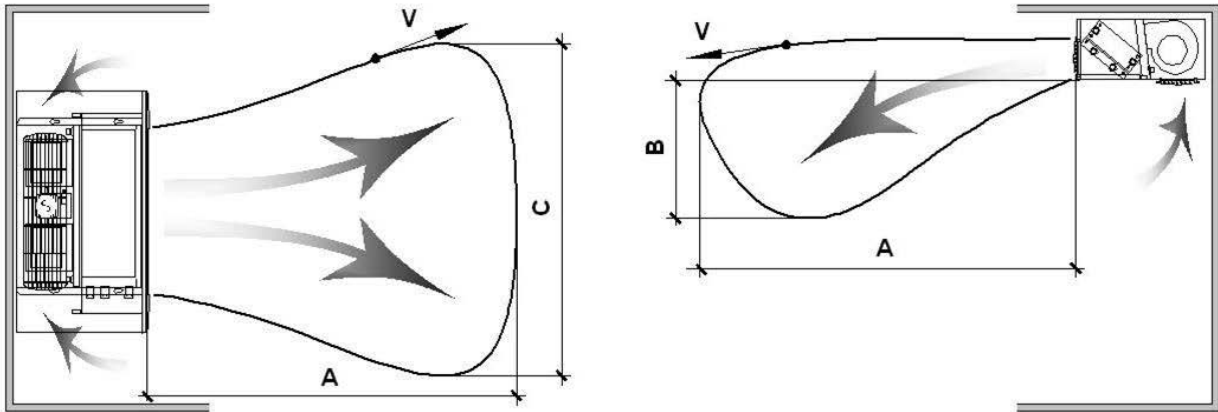

ELFOSpace			003.0	005.0	007.0	009.0	011.0	015.0	017.0	021.0	025.0	031.0	041.0	051.0
Q <sup>(1)</sup>	H	[m³/h]	370	400	500	550	670	720	1000	1050	1280	1310	1910	1940
	M	[m³/h]	285	308	400	440	590	634	890	935	1139	1166	1643	1668
	L	[m³/h]	226	244	305	336	462	497	650	683	870	891	1490	1513
H (V)	A	[m]	3,8	4,1	3,7	4,1	4,0	4,3	4,9	5,1	5,4	5,5	6,9	7,0
	B	[m]	1,0	1,1	1,0	1,1	1,0	1,1	1,2	1,3	1,4	1,4	1,7	1,7
	C	[m]	1,7	1,8	1,9	2,0	2,2	2,3	2,7	2,8	3,1	3,1	3,8	3,9
M (V)	A	[m]	3,0	3,2	3,1	3,3	3,6	3,8	4,4	4,6	4,8	4,9	6,0	6,1
	B	[m]	0,8	0,9	0,8	0,9	0,9	1,0	1,1	1,2	1,2	1,2	1,5	1,5
	C	[m]	1,5	1,5	1,7	1,8	2,1	2,1	2,5	2,6	2,9	2,9	3,5	3,5
L (V)	A	[m]	2,4	2,6	2,4	2,6	2,8	3,1	3,3	3,5	3,8	3,9	5,5	5,6
	B	[m]	0,7	0,7	0,7	0,7	0,8	0,8	0,9	0,9	1,0	1,0	1,4	1,4
	C	[m]	1,2	1,3	1,4	1,5	1,8	1,9	2,2	2,2	2,5	2,6	3,3	3,4

(1) Technical data referred to the following conditions:

- Standard Unit (without installed accessories)
- Electrical power 230V/1Ph/50Hz
- Atmospheric pressure 1013 bar
- Rated technical data with free outlet (ESP = 0 Pa). Values taken with tank ref. law AMCA 210-74 duct + diaphragm ref. law CNR-UNI 10023

Lengend:

- Q = Air flow
- V = Fan speed (0,25 m/s)
- H = High speed
- M = Medium speed
- L = Low speed

Page intentionally left blank



**CLIVET SPA**

Via Camp Lonc 25, Z.I. Villapaiera - 32032 Feltre (BL) - Italy  
Tel. + 39 0439 3131 - Fax + 39 0439 313300 - info@clivet.it

**CLIVET GROUP UK LIMITED**

4 Kingdom Close, Segensworth East - Fareham, Hampshire - PO15 5TJ - United Kingdom  
Tel. + 44 (0) 1489 572238 - Fax + 44 (0) 1489 573033 - enquiries@clivetgroup.co.uk

**CLIVET GROUP UK Limited (Service Department)**

Units F5&F6 Railway Triangle Ind Est, Walton Road - Portsmouth, Hampshire - PO6 1TG - United Kingdom  
Tel. +44 (0) 2392 381235 - Fax. +44 (0) 2392 381243 - service@clivetgroup.co.uk

**CLIVET ESPAÑA S.A.U.**

C/ Bac de Roda, 36 - 08019 Barcelona - España  
Tel: +34 93 8606248 - Fax +34 93 8855392 - info@clivet.es

Av.Manoteras Nº 38, Oficina C303 - 28050 Madrid - España  
Tel. +34 91 6658280 - Fax +34 91 6657806 - info@clivet.es

**CLIVET GmbH (Hydronic and Applied Division)**

Hummelsbütteler Steindamm 84, 22851 Norderstedt - Germany  
Tel. + 49 (0) 40 32 59 57-0 - Fax + 49 (0) 40 32 59 57-194 - info.de@clivet.com

**CLIVET GmbH (VRF, Residential and Lightcom Division)**

Eisenstrasse 9c, 65428 Rüsselsheim/Frankfurt - Germany  
Tel. + 49 (0) 6142 83594-0 - Fax + 49 (0) 6142 83594-20 - vrf.de@clivet.com

**CLIVET RUSSIA**

Elektrozavodskaya st. 24, office 509 - 107023, Moscow, Russia  
Tel. + 74956462009 - Fax + 74956462009 - info.ru@clivet.com

**CLIVET MIDEAST FZCO**

Dubai Silicon Oasis (DSO), High Bay Complex, Office N. 20, PO BOX 342009, Dubai, UAE  
Tel. + 9714 3208499 - Fax + 9714 3208216 - info@clivet.ae

**CLIVET AIRCONDITIONING SYSTEMS PRIVATE LIMITED**

4BA, Gundecha Onclave, Kherani Road - Sakinaka, Andheri (East) - Mumbai 400 072 - India  
Tel. +91 22 6193 7000 - Fax +91 22 6193 7001 - info.in@clivet.com

---

[www.clivet.com](http://www.clivet.com)  
[www.clivetlive.com](http://www.clivetlive.com)

A Group Company of

