

MSAT-XEE

Air cooled condensing unit for outdoor installation

SERIES MSAT-XEE 8.2-30.2

Nominal cooling capacity from 26 to 80kW

- ▶ **HIGH ENERGY EFFICIENCY**
Particularly in the operation at partial loads thanks to the use of two compressors with different capacity that operate on a single circuit
- ▶ **CONDENSING CONTROL**
The pressure transducer modulates the fans speed according to the outdoor air temperature and to the refrigeration circuit pressure, expanding the unit operation limits and maintaining the best heat exchange conditions.
- ▶ **REDUCED OVERALL SIZE**
The units are designed to reduce at minimum the overall dimensions, decisive factor to adapt to the features of any building



Standard unit technical specifications

Compressor

Hermetic Scroll compressors, equipped with a motor protection device for overheating, overcurrents and excessive temperatures of the supply gas. Mounted on rubber vibration dampers complete with oil charge.

An oil heater is automatically activated to prevent the oil from being diluted by the refrigerant when the compressor stops.

Structure

Structure made entirely in Zinc–Magnesium plate that guarantees excellent mechanical characteristics and high corrosion strength over time.

Panelling

External pre-painted Zinc-Magnesium panelling that ensures superior resistance to corrosion for outdoor installation and eliminates the need for periodical painting.

The panels can be easily removed to fully access internal components and are lined with sound-proof material on the inside to contain the unit's sound levels.

External exchanger

Finned exchanger, made from copper pipes arranged in staggered rows and mechanically expanded for better adherence to the collar of the fins. The fins are made from aluminium with a special corrugated surface, set a suitable distance apart to ensure maximum heat exchange efficiency.

Fan

From size 8.2 to 12.2:

Low speed axial fan directly driven by single phase external rotor motor with incorporated thermal overload. Housed in aerodynamically shaped enclosures to increase the efficiency and reduce the noise level. Complete with fan guard in order to help against fortuitous contact with the blades.

From size 16.2 to 30.2:

Low speed axial fan directly driven by three phase external rotor motor with incorporated thermal overload. Housed in aerodynamically shaped enclosures to increase the efficiency and reduce the noise level. Complete with fan guard in order to help against fortuitous contact with the blades.

Refrigeration circuit

Refrigeration circuit with:

- filter dryer
- sight glass with moisture and liquid indicator
- high pressure safety pressure switch
- low pressure safety switch
- liquid receiver
- compressor suction shut-off valve
- cutoff valve on liquid line
- high pressure safety
- pressure probes

Electrical panel

The capacity section includes:

- isolating transformer for auxiliary circuit power supply
- main line isolator switch
- compressor overload cutout switch
- fan fuses
- compressor control contactor
- phase cutting fan speed controller (pressure)
- terminals for the link to internal unit and power supply.

The control section includes:

- microprocessor control
- compressor overload protection and timer
- separate alarms visualization (high pressure, low pressure, overload compressor, probe breakdown)
- centralised alarms with remote signalling
- condenser control allows the unit to operate, in cooling only, at low outside air temperatures (temperature actuated fans speed control)
- free contacts for cumulative signals of the alarms
- serial port with Modbus (RS 485) output for remote communication

Accessories

- AMRX - Rubber antivibration mounts
- PGCEX - Coil protection grilles outdoor air side
- RCTX - Remote control
- PMX - Phase monitor
- KCX - Connection set

Configuration Code

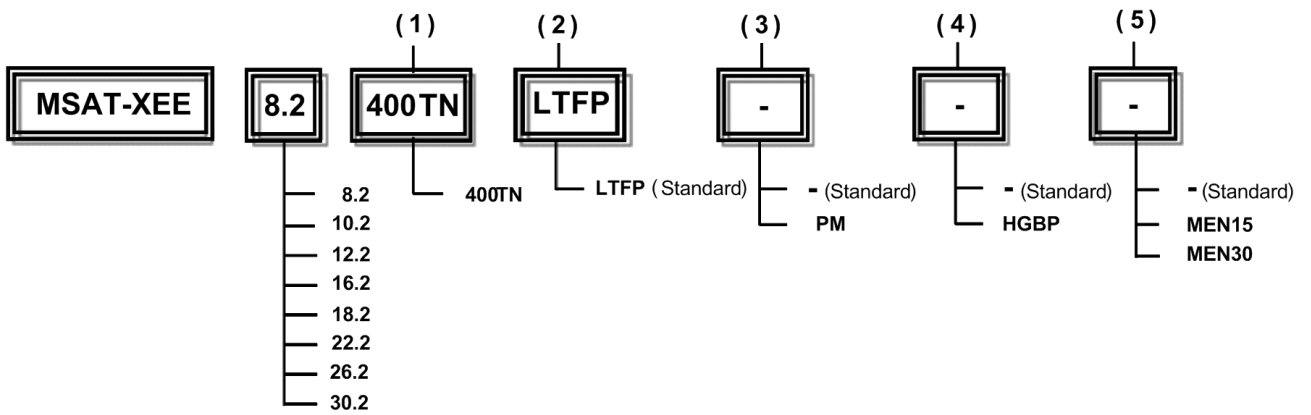

(1) Voltage

Supply voltage 400/3/50+N (400TN)

Standard

(2) Phase cutting fans

Phase cutting fans (LTFP)

Standard

(3) Phase monitor

Phase monitor: not required (-)

Standard

Phase monitor (PM)

(4) Hot gas by pass

Hot gas by pass: not required (-)

Standard

Hot gas by pass (HGBP)

(5) Minimum outdoor air temperature

Minimum outdoor air temperature -10°C (-)

Standard

Minimum external air temperature down to -15°C (MEN15)

Minimum external air temperature down to -30°C (MEN30)

General technical data

Size			8.2	10.2	12.2	16.2	18.2	22.2	26.2	30.2
Cooling										
Cooling capacity	1	kW	25,7	31,3	36,0	43,4	51,6	59,1	72,3	80,1
Compressor power input	1	kW	8,79	9,95	12,4	14,1	16,2	20,3	22,6	26,6
Total power input	1	kW	9,2	10,4	12,9	15,6	17,7	21,8	24,2	28,4
EER	1		2,78	3,01	2,80	2,78	2,91	2,71	2,99	2,82
Compressor										
Type of compressors			SCROLL	SCROLL	SCROLL	SCROLL	SCROLL	SCROLL	SCROLL	SCROLL
Refrigerant			R-410A	R-410A	R-410A	R-410A	R-410A	R-410A	R-410A	R-410A
No. of compressors		No	2	2	2	2	2	2	2	2
Std Capacity control steps		No	2	2	2	2	2	2	2	2
Oil charge (C1)		l	3,61	3,72	3,54	5,76	5,76	6,65	7,39	8,28
Refrigerant charge (C1)	2	kg	6,4	9,2	9,2	8,0	11,6	11,6	14,9	14,9
Refrigeration circuits		No	1	1	1	1	1	1	1	1
External Section Fans										
Type of fans			AX	AX	AX	AX	AX	AX	AX	AX
Number of fans		No	2	2	2	1	1	1	2	2
Standard airflow		l/s	2553	2545	2514	4965	4902	4778	7196	6971
Installed unit power		kW	0,25	0,25	0,25	1,72	1,72	1,72	0,90	0,90
Connections										
Gas connection		mm	28	28	28	35	35	35	42	42
Liquid connection		mm	16	16	16	22	22	22	22	22
Power supply										
Standard power supply		V	400/3/50+N	400/3/50+N	400/3/50+N	400/3/50+N	400/3/50+N	400/3/50+N	400/3/50+N	400/3/50+N
Noise Levels										
Sound pressure level (1 m)	3	dB(A)	60	60	60	64	64	65	65	65
Dimensions										
A - Length		mm	1771	1771	1771	2012	2012	2012	2406	2406
B - Width		mm	680	680	680	1100	1100	1100	1100	1100
C - Height		mm	1287	1287	1287	1599	1599	1599	1593	1593
Standard unit weights										
Shipping weight		kg	294	299	318	444	456	477	526	539
Operating weight		kg	288	293	313	436	449	470	517	531

1. saturated suction temperature (SST) = 5 °C, outdoor air temperature 35°C

2. Refrigerant charge relating only to the condensing unit to be integrated according to the installation and to the evaporating internal unit.

3. Sound levels refer to units with full load under nominal test conditions. The sound pressure is measured at 1 m from the external surface of the unit in open field conditions.

Electrical data

Size			8.2	10.2	12.2	16.2	18.2	22.2	26.2	30.2
F.L.A. - Full load current at max admissible conditions										
F.L.A. - Compressor 1		A	10,1	10,1	14,3	15,4	15,4	15,4	22,7	30,6
F.L.A. - Compressor 2		A	10,2	14,3	14,3	16,4	22,7	30,6	30,6	30,6
F.L.A. - Single External Fan		A	1,18	1,18	1,18	3,90	3,90	3,90	2,35	2,35
F.L.A. - Total		A	22,7	26,8	31,0	35,7	42,0	49,9	58,0	65,9
L.R.A. - Locked rotor amperes										
L.R.A. - Compressor 1		A	64,0	64,0	101	95,0	95,0	95,0	118	174
L.R.A. - Compressor 2		A	64,0	101	101	111	118	174	174	174
F.L.I. - Full load power input at max admissible conditions										
F.L.I. - Compressor 1		kW	6,00	6,00	8,30	9,00	9,00	9,00	13,3	17,0
F.L.I. - Compressor 2		kW	6,00	8,30	8,30	10,1	13,3	17,0	17,0	17,0
F.L.I. - Single External Fan		kW	0,27	0,27	0,27	1,94	1,94	1,94	1,03	1,03
F.L.I. - Total		kW	12,5	14,8	17,1	21,0	24,2	27,9	32,4	36,1
M.I.C. Maximum inrush current										
M.I.C. - Value		A	78,1	115	119	132	139	196	204	212

Power supply: 400/3/50 Hz. Voltage variation: max. +/-10%

Voltage unbalance between phases: max 2 %

For non standard voltage please contact Clivet technical office

The units are compliant with the provisions of European standards CEI EN 60204 and CEI EN 60335.

Sound levels

Size	Sound power level (dB)								Sound power level	Sound pressure level
	Octave band (Hz)									
	63	125	250	500	1000	2000	4000	8000	dB(A)	dB(A)
8.2	80	75	78	73	70	66	58	52	75	60
10.2	79	74	77	73	70	66	60	51	75	60
12.2	79	74	77	72	70	67	61	52	75	60
16.2	89	82	78	80	77	69	64	59	81	64
18.2	89	82	77	79	77	71	66	60	81	64
22.2	89	82	80	81	77	72	64	59	82	65
26.2	89	82	79	80	78	73	67	59	82	65
30.2	89	82	80	81	76	73	64	57	82	65

The sound pressure level refers to a distance of 1m from the external surface of the units operating in an open field.

Data referred to the following conditions :
 Internal exchanger water = 12/7°C
 Outdoor air temperature 35°C

Operating limits

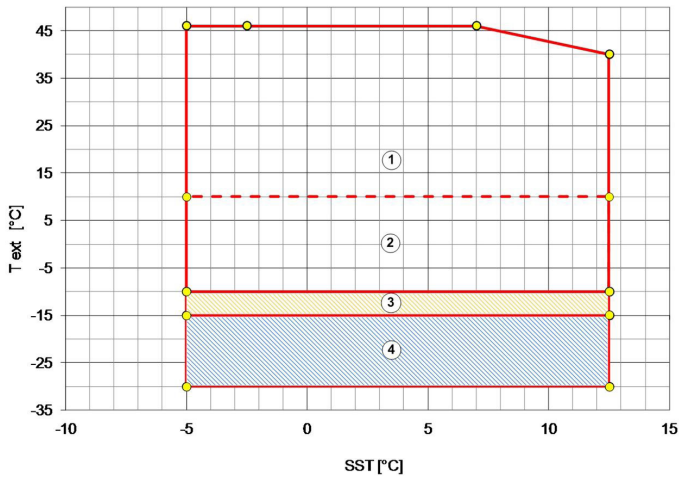

SST = saturated suction temperature, corresponding to the compressor suction pressure (°C)
 Suction gas superheating +5° K

1. Standard operating range
2. Operating range with modulating fans
3. Operating range with option: Min. external temperature down to -15°C (MEN15)
4. Operating range with option: Min. external temperature down to -30°C (MEN30)

Performances in cooling

Size	SST	Outdoor air temperature													
		25		30		32		35		40		43		46	
		kWf	kWe	kWf	kWe	kWf	kWe	kWf	kWe	kWf	kWe	kWf	kWe	kWf	kWe
8.2	-2.5	23,4	6,82	22,0	7,58	21,4	7,92	20,4	8,44	18,5	9,39	17,3	10,0	16,2	10,7
	0	25,3	6,91	23,8	7,67	23,1	8,02	22,1	8,55	20,1	9,49	18,9	10,2	17,7	10,9
	5	29,6	7,17	27,8	7,94	27,0	8,28	25,7	8,79	23,5	9,70	22,3	10,4	21,3	11,1
	7	31,3	7,30	29,5	8,05	28,6	8,40	27,2	8,91	24,9	9,83	23,7	10,5	22,9	11,2
	10	34,1	7,47	31,9	8,24	31,0	8,57	29,6	9,07	27,2	9,99	26,1	10,7	26,9	11,7
	12.5	36,5	7,65	34,2	8,39	33,2	8,72	31,6	9,22	29,1	10,2	28,2	10,9	-	-
10.2	-2.5	28,2	7,53	26,7	8,42	26,0	8,81	24,9	9,40	22,9	10,5	21,5	11,3	20,2	12,1
	0	30,5	7,70	28,8	8,59	28,1	8,99	26,9	9,58	24,7	10,7	23,4	11,4	22,1	12,2
	5	35,6	8,11	33,5	9,00	32,6	9,38	31,3	9,95	28,7	11,1	27,3	11,8	26,0	12,6
	7	37,7	8,32	35,6	9,19	34,6	9,57	33,1	10,1	30,5	11,2	29,0	12,0	27,8	12,8
	10	41,0	8,60	38,7	9,48	37,6	9,86	36,0	10,4	33,1	11,5	31,7	12,3	30,8	13,1
	12.5	44,0	8,89	41,4	9,74	40,2	10,1	38,3	10,7	35,5	11,8	34,2	12,6	-	-
12.2	-2.5	33,0	9,36	31,0	10,4	30,2	10,9	28,8	11,5	26,4	12,8	24,9	13,6	23,5	14,5
	0	35,7	9,66	33,5	10,7	32,5	11,1	31,1	11,8	28,5	13,1	27,0	13,9	25,8	14,8
	5	41,4	10,3	38,8	11,3	37,7	11,8	36,0	12,4	33,1	13,7	31,7	14,5	30,8	15,5
	7	43,9	10,5	41,1	11,6	39,9	12,1	38,1	12,7	35,1	14,0	33,8	14,8	-	-
	10	47,6	11,0	44,6	12,0	43,3	12,5	41,3	13,2	38,2	14,4	37,2	15,4	-	-
	12.5	50,9	11,4	47,5	12,4	46,2	12,9	44,2	13,5	41,3	14,8	40,8	15,8	-	-
16.2	-2.5	39,4	10,8	37,1	12,0	36,1	12,5	34,6	13,2	31,5	14,7	29,6	15,7	27,9	16,8
	0	42,6	11,1	40,1	12,2	39,0	12,7	37,3	13,5	34,1	14,9	32,2	16,0	30,5	17,0
	5	49,7	11,7	46,7	12,9	45,4	13,4	43,4	14,1	39,8	15,5	37,8	16,5	36,4	17,7
	7	52,5	12,0	49,4	13,2	48,0	13,6	45,9	14,4	42,2	15,8	40,2	16,8	39,0	18,0
	10	57,2	12,5	53,6	13,6	52,0	14,1	49,7	14,8	45,7	16,3	44,0	17,3	-	-
	12.5	61,2	13,0	57,2	14,0	55,4	14,5	52,9	15,3	49,0	16,7	47,6	17,7	-	-
18.2	-2.5	47,1	12,5	44,5	13,8	43,2	14,4	41,3	15,2	37,7	16,9	35,4	18,0	33,2	19,2
	0	50,9	12,7	48,0	14,0	46,6	14,6	44,6	15,5	40,7	17,2	38,4	18,3	36,1	19,5
	5	59,3	13,4	55,8	14,7	54,1	15,3	51,6	16,2	47,3	17,8	44,8	18,9	42,8	20,2
	7	62,8	13,7	58,9	15,0	57,2	15,6	54,6	16,5	50,1	18,1	47,6	19,3	45,7	20,6
	10	68,2	14,2	64,1	15,5	62,1	16,1	59,2	17,0	54,3	18,6	52,0	19,7	50,8	21,2
	12.5	73,0	14,6	68,3	15,9	66,2	16,5	63,1	17,4	58,2	19,0	56,0	20,3	-	-
22.2	-2.5	54,8	15,7	51,5	17,2	50,0	17,8	47,8	18,8	43,7	20,6	41,4	21,9	39,2	23,2
	0	59,0	16,2	55,4	17,7	53,8	18,3	51,4	19,3	47,0	21,0	44,7	22,3	42,7	23,7
	5	68,3	17,2	64,0	18,7	62,0	19,3	59,1	20,3	54,4	22,1	52,2	23,4	53,5	25,3
	7	72,3	17,6	67,5	19,1	65,5	19,8	62,5	20,7	57,7	22,5	55,6	-	-	-
	10	78,2	18,3	72,9	19,8	70,7	20,5	67,4	21,4	62,5	23,2	60,9	-	-	-
	12.5	83,4	18,9	77,5	20,5	75,2	21,1	71,8	22,1	67,0	23,9	66,7	-	-	-
26.2	-2.5	66,2	17,5	62,4	19,3	60,6	20,0	58,0	21,2	52,9	23,3	49,9	24,7	47,0	26,2
	0	71,4	17,9	67,2	19,7	65,3	20,5	62,5	21,6	57,2	23,7	54,0	25,1	51,1	26,7
	5	83,0	18,9	78,1	20,7	75,8	21,4	72,3	22,6	66,2	24,7	63,0	26,2	60,4	27,8
	7	87,9	19,3	82,6	21,1	80,2	21,9	76,5	23,0	70,3	25,1	67,0	26,6	64,6	28,3
	10	95,6	19,9	89,5	21,8	86,8	22,5	82,8	23,7	76,3	25,8	73,2	27,3	75,2	29,5
	12.5	102	20,5	95,5	22,3	92,6	23,1	88,4	24,3	81,6	26,5	78,8	28,0	-	-
30.2	-2.5	73,9	20,7	69,5	22,6	67,5	23,4	64,5	24,7	59,0	27,0	55,9	28,5	53,2	30,1
	0	79,5	21,4	74,8	23,3	72,6	24,1	69,5	25,2	63,6	27,5	60,5	29,0	57,9	30,7
	5	92,0	22,7	86,2	24,6	83,8	25,4	80,1	26,6	73,4	28,9	70,5	30,4	72,4	32,7
	7	97,6	23,1	91,3	25,1	88,6	25,9	84,5	27,2	77,7	29,5	74,9	31,1	-	-
	10	106	24,0	98,6	26,0	95,6	26,8	91,2	28,1	84,4	30,3	82,1	31,9	-	-
	12.5	113	24,7	105	26,7	102	27,6	97,1	28,9	90,5	31,2	89,3	32,9	-	-

kWf = Cooling capacity in kW

kWe = Compressor power input in kW

SST = saturated suction temperature, corresponding to the compressor suction pressure (°C)

Suction gas superheating +5°K

Configurations

PMX - Phase monitor

Phase monitor to check the presence and correct sequence of the power supply phases



HGBP - Hot gas by pass

The hot gas by pass allows terminal/condensing unit operation with internal exchanger air temperature lower than standard, keeping the compressor suction pressure above the min. enabled value. This is possible because some part of the compressor outlet air (HOT GAS) enter directly in evaporating coil raising up the temperature, avoiding the ice on evaporator.

MEN15 - Min external air temperature down to -15°C

Heated electrical panel

MEN30 - Min external air temperature down to -30°C

Heated electrical panel, condensing coil bypass valve, heated liquid receiver, liquid line solenoid

Accessories separately supplied

Each accessory is marked by a configuration code, e.g. CMMB8X. If the last letter is X, it means that the accessory is provided separately. If the code does not contain the letter X, the accessory is installed at the factory.

PMX - Phase monitor

Phase monitor to check the presence and correct sequence of the power supply phases



RCTX - Remote control

The remote control allows the remote display and operation of functions of the microprocessor on the unit

AMRX - Rubber antivibration mounts

The rubber antivibration mounts reduce the vibrations of compressor during its operation and they are installed at the base toe.

PGCEX - Coil protection grilles outdoor air side

The protection battery pack grilles, protect fins from accidental bumps.

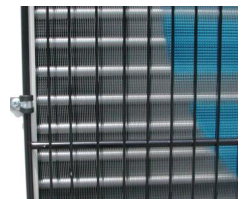

KCX - Connection set

Thermal expansion valve, filter dryer, sight glass, check valve.

Dimensional drawing

Size 8.2 - 10.2 - 12.2

DAA9G8.2 DATA 13/02/2014

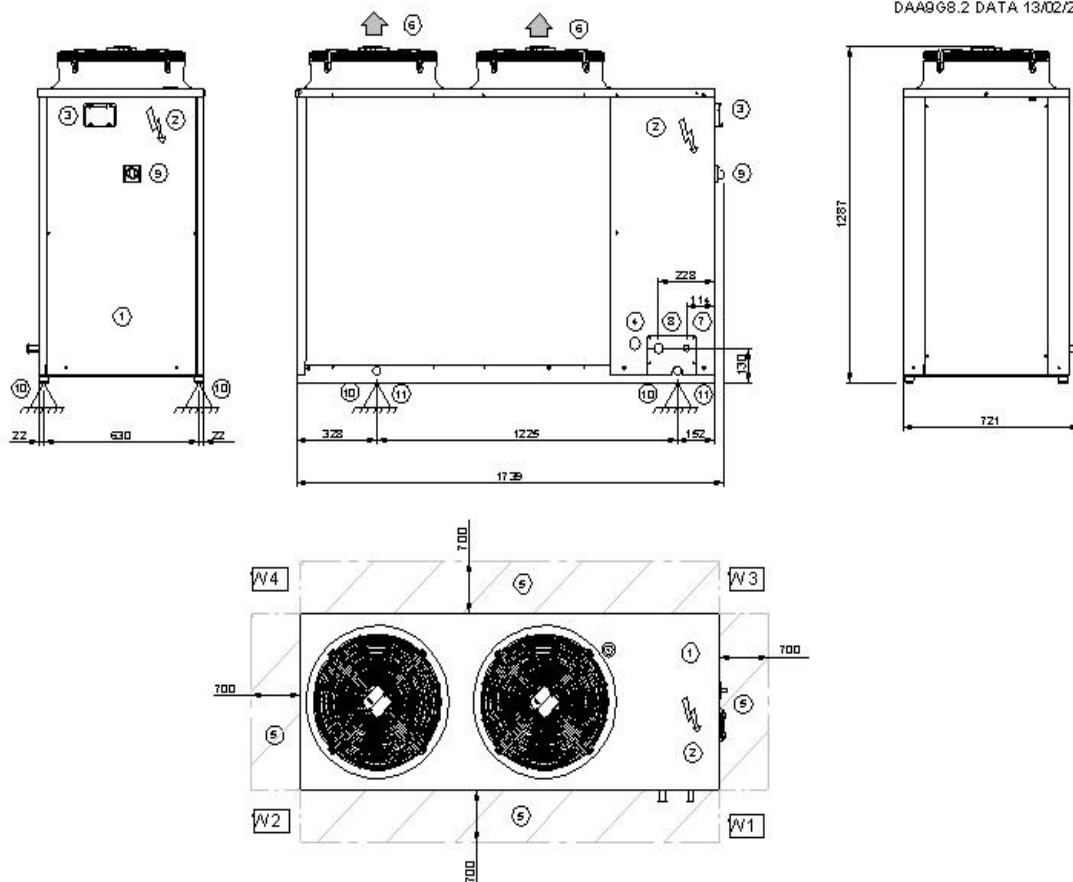

- | | |
|--------------------------------|---------------------------------|
| 1. Compressor compartment | 8. Suction line piping d.28 mm. |
| 2. Electrical panel | 9. Main isolator switch |
| 3. Unit control keypad | 10. Vibration mounts position |
| 4. Power input | 11. Lifting holes position |
| 5. Functional spaces | |
| 6. Air supply | |
| 7. liquid line piping d.16 mm. | |

Size		8.2	10.2	12.2
A - Length	mm	1739	1739	1739
B - Width	mm	721	721	721
C - Height	mm	1287	1287	1287
Shipping weight	kg	304	309	329
Operating weight	kg	298	303	323

The presence of optional accessories may result in a substantial variation of the weights shown in the table.

Size 16.2 - 18.2 - 22.2

DAA9G16.2_00 DATA 13/02/2014

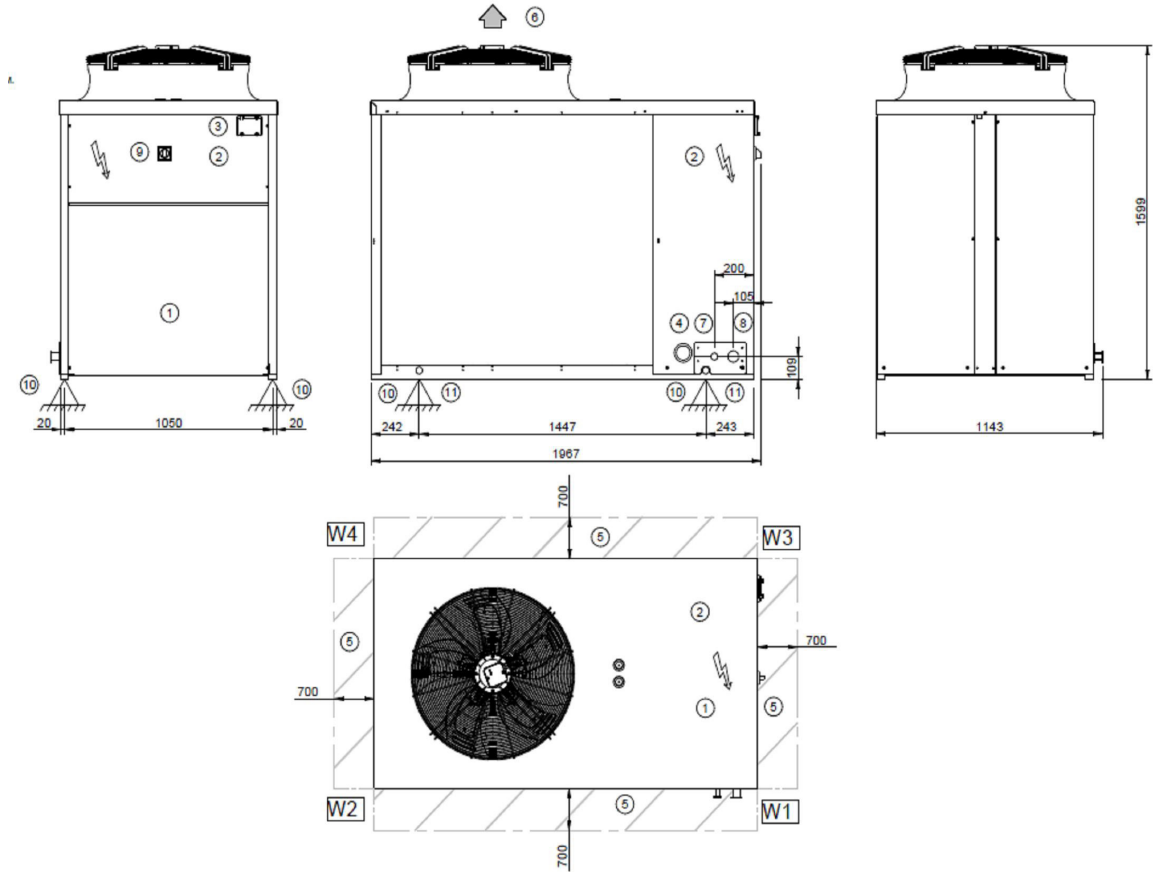

- 1. Compressor compartment
- 2. Electrical panel
- 3. Unit control keypad
- 4. Power input
- 5. Functional spaces
- 6. Air supply
- 7. liquid line piping d.16 mm.
- 8. Suction line piping d.28 mm.
- 9. Main isolator switch
- 10. Vibration mounts position
- 11. Lifting holes position

Size		16.2	18.2	22.2
A - Length	mm	1967	1967	1967
B - Width	mm	1143	1143	1143
C - Height	mm	1599	1599	1599
Shipping weight	kg	464	476	497
Operating weight	kg	456	469	490

The presence of optional accessories may result in a substantial variation of the weights shown in the table.

Size 26.2 - 30.2

DAA9G26.2_00 DATA 13/02/2014

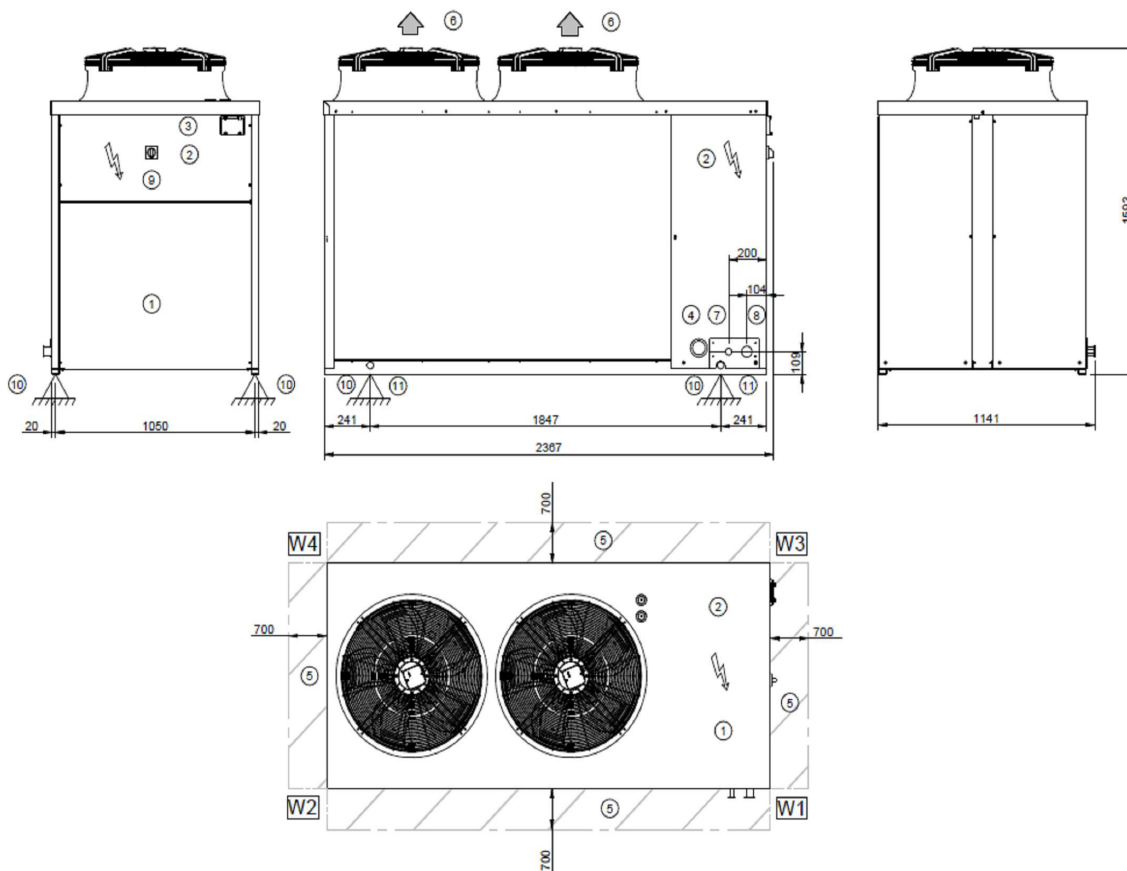

- | | |
|--------------------------------|---------------------------------|
| 1. Compressor compartment | 8. Suction line piping d.28 mm. |
| 2. Electrical panel | 9. Main isolator switch |
| 3. Unit control keypad | 10. Vibration mounts position |
| 4. Power input | 11. Lifting holes position |
| 5. Functional spaces | |
| 6. Air supply | |
| 7. liquid line piping d.16 mm. | |

Size		26.2	30.2
A - Length	mm	2367	2367
B - Width	mm	1141	1141
C - Height	mm	1593	1593
Shipping weight	kg	556	569
Operating weight	kg	547	561

The presence of optional accessories may result in a substantial variation of the weights shown in the table.



CLIVET SPA

Via Camp Lonc 25, Z.I. Villapaiera - 32032 Feltre (BL) - Italy
Tel. + 39 0439 3131 - Fax + 39 0439 313300 - info@clivet.it

CLIVET UK LTD (Sales)

4 Kingdom Close, Segensworth East - Fareham, Hampshire - PO15 5TJ - United Kingdom
Tel. + 44 (0) 1489 572238 - Fax + 44 (0) 1489 573033 - info@clivet-uk.co.uk

CLIVET AIRCON LTD (Service and Maintenance Division)

Units F5&F6 Railway Triangle Ind EST, Walton Road - Portsmouth, Hampshire - PO6 1TG - United Kingdom
Tel. + 44 (0) 2392 381235 - Fax + 44 (0) 2392 381243 - info@clivetaircon.co.uk

CLIVET ESPAÑA COMERCIAL S.L. (Sales)

Calle Gurb, 17 1º 1ª - 08500 Vic, Barcelona - España
Tel. + 34 93 8606248 - Fax + 34 93 8855392 - info@clivetcomercial.es

CLIVET ESPAÑA S.A.U. (Service and Maintenance Division)

Calle Real de Burgos nº12 - 28860, Paracuellos del Jarama, Madrid - España
Tel. + 34 91 6658280 - Fax + 34 91 6657806 - info@clivet.es

CLIVET GmbH

Hummelsbütteler Steindamm 84, 22851 Norderstedt - Germany
Tel. + 49 (0) 40 32 59 57-0 - Fax + 49 (0) 40 32 59 57-194 - info.de@clivet.com

CLIVET RUSSIA

Elektrozavodskaya st. 24, office 509 - 107023, Moscow, Russia
Tel. + 74956462009 - Fax + 74956462009 - info.ru@clivet.com

CLIVET MIDEAST FZCO

Dubai Silicon Oasis (DSO), High Bay Complex, Ind Unit No. 3 - PO Box 342009 - DUBAI, UAE
Tel. + 97 14 3208499 - Fax + 97 14 3208216 - info@clivet.ae

CLIVET AIRCONDITIONING SYSTEMS PRIVATE LTD

3C3, Gundecha Onclave - Kherani Road, Saki Naka, Andheri (East), Mumbai 400 072 (INDIA)
Tel. + 91 - 22 - 6193 7000 - Fax + 91 - 22 - 6193 7001 - sales.india@clivet.com