



INSTALLATION AND OPERATING MANUAL

Box - SL 950x950

SUPER-SLIM FOUR-WAY CASSETTE



BOX-SL2 (for LIGHT Commercial systems):
Series S.IA2+MC2-Y from 70M to 160T

Nominal cooling capacity
from 7,0 kW to 16,1 kW



Change living home

Table of Contents

Installation Manual



IMPORTANT NOTE:

Read this manual carefully before installing or operating your new air conditioning unit. Make sure to save this manual for future reference.

1	Accessories	04
2	Safety Precautions	05
3	Installation Overview	08

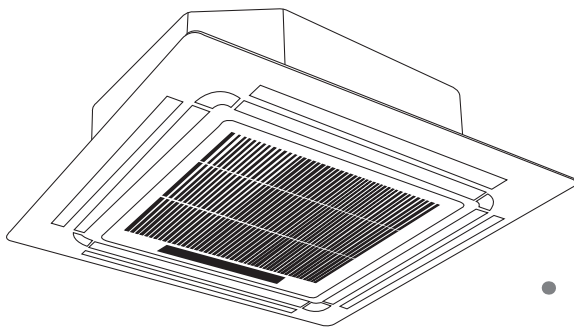
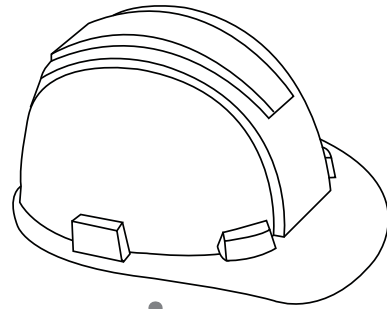

4	Indoor Unit Installation	09
	Indoor Unit Parts	09
	Indoor Unit Installation Instructions	10

5	Outdoor Unit Installation	13
	Outdoor Unit Installation Instructions	13
	Drain Joint Installation	15
	Notes on Drilling Hole in Wall	15

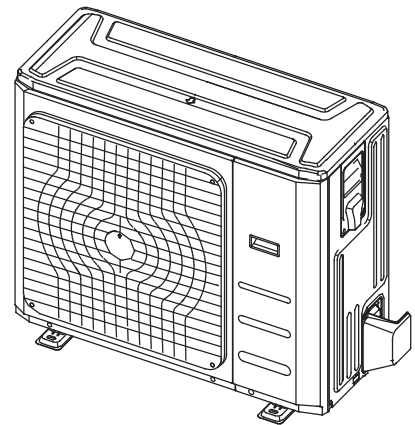

6	Drainpipe Installation	16
----------	------------------------------	----

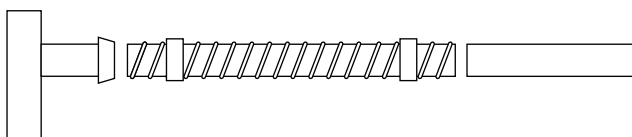

7	Refrigerant Piping Connection	18
	Notes on Pipe Length and Elevation	18
	Refrigerant Piping Connection Instructions	20

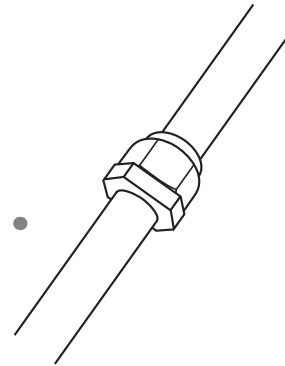
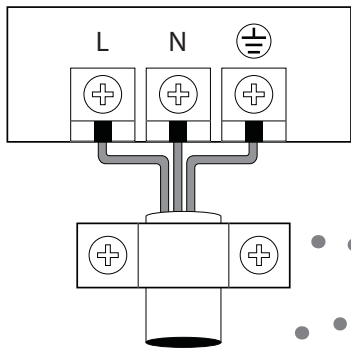

8	Wiring	23
	Outdoor Unit Wiring	23
	Indoor Unit Wiring	24
	Power Specifications	25

9	Air Evacuation	27
	Evacuation Instructions	27
	Note on Adding Refrigerant	28

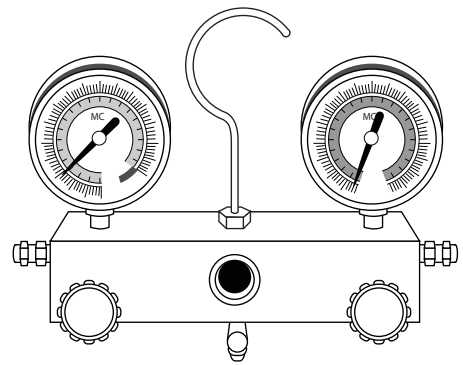

Caution : Risk of fire
(R32/R290 refrigerant)









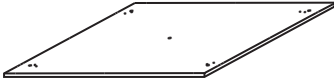

10	Panel Installation	29
11	Test Run	31
12	European Disposal Guidelines	32
13	Information Servicing	33
14	Technical information	38

Wiring diagrams at the
end of the manual

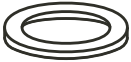
Accessories

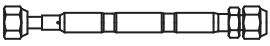
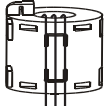
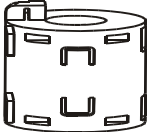
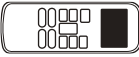
1

The air conditioning system comes with the following accessories. Use all of the installation parts and accessories to install the air conditioner. Improper installation may result in water leakage, electrical shock and fire, or cause the equipment to fail.

	Name	Shape	Quantity
Indoor unit installation	Installation paper template (some models)		1
Refrigeration Fittings	Soundproof/insulation sheath (some models)		1
Drainpipe Fittings	Outlet pipe sheath (some models)		1
	Outlet pipe clasp (some models)		1
	Drain joint (some models)		1
	Seal ring (some models)		1
Installation Accessory (some models)	Ceiling hook		4
	Suspension bolt		4
	Orifice tube (some units)		1
EMC Magnetic Ring (some models)	Magnetic ring (wrap the electric wires S1 & S2 (P & Q & E) around the magnetic ring twice)	 S1&S2(P&Q&E)	1
	Magnetic ring (Hitch it on the connective cable between indoor unit and outdoor unit after installation.)		1
Remote controller & Its Frame (some models)	Remote controller		1
	Fixing screw for remote controller holder ST2.9 x 10		2
	Remote controller holder		1
	Dry battery AAA		2
	Remote controller illustration	---	1
others	Installation and operating manual	---	1

Read Safety Precautions Before Installation

Incorrect installation due to ignoring instructions can cause serious damage or injury.

The seriousness of potential damage or injuries is classified as either a WARNING or CAUTION.



WARNING

Failure to observe a warning may result in death. The appliance must be installed in accordance with national regulations.



CAUTION

Failure to observe a caution may result in injury or equipment damage.

WARNING

- Carefully read the Safety Precautions before installation.
- In certain functional environments, such as kitchens, server rooms, etc., the use of specially designed air-conditioning units is highly recommended.
- Only trained and certified technicians should install, repair and service this air conditioning unit.
Improper installation may result in electrical shock, short circuit, leaks, fire or other damage to the equipment and personal property.
- Strictly follow the installation instructions set forth in this manual.
Improper installation may result in electrical shock, short circuit, leaks, fire or other damage to the equipment.
- An The power supply line must have upstream to appropriate protection against short circuits and earth faults that section the system with respect to other users. The qualified technician must use an approved circuit breaker or switch.
- Before you install the unit, consider strong winds, typhoons and earthquakes that might affect your unit and locate it accordingly. Failure to do so could cause the equipment to fail.
- After installation, ensure there are no refrigerant leaks and that the unit is operating properly. Refrigerant is both toxic and flammable and poses a serious health and safety risk.
- This appliance can be used by children aged from 8 years and above and persons with reduced physical, sensory or mental capabilities or lack of experience and knowledge if they have been given supervision or instruction concerning use of the appliance in a safe way and understand the hazards involved. Children shall not play with the appliance. Cleaning and user maintenance shall not be made by children without supervision.
- Do not use means to accelerate the defrosting process or to clean, other than those recommended by the manufacturer.
- The appliance shall be stored so as to prevent mechanical damage from occurring.

! WARNING

- The appliance disconnection must be incorporated with an all-pole disconnection device in the fixed wiring in accordance with the wiring rules.
- Any person who is involved with working on or breaking into a refrigerant circuit should hold a current valid certificate from an industry-accredited assessment authority, which authorises their competence to handle refrigerants safely in accordance with an industry recognised assessment specification.
- Servicing shall only be performed as recommended by the equipment manufacturer. Maintenance and repair requiring the assistance of other skilled personnel shall be carried out under the supervision of the person competent in the use of flammable refrigerants.
- The appliance shall be stored so as to prevent mechanical damage from occurring.
- Keep ventilation openings clear of obstruction.

NOTE: The following informations are required for the units adopt R32/R290 Refrigerant.





- The appliance shall be stored in a room without continuously operating ignition sources (for example: open flames, an operating gas appliance or an operating electric heater).
- Do not pierce or burn.
- Be aware that the refrigerants may not contain an odour.
- Compliance with national gas regulations shall be observed.
- Appliance shall be stored in a well-ventilated area where the room size corresponds to the room area as specified for operation.
- Appliance shall be installed, operated and stored in a room with a floor area larger than X m², installation of pipe-work shall be kept to a minimum X m²(Please see the following form). The appliance shall not be installed in an unventilated space, if that space is smaller than X m² (Please see the following form).Spaces where refrigerant pipes shall be compliance with national gas regulations.

Model (Btu/h)	Amount of refrigerant to be charged (kg)	maximum installation height (m)	Minimum room area (m ²)
≤30000	≤2.048	2.2m	4
30000-48000	2.048-3.0	2.2m	4
>48000	>3.0	2.2m	5

Note about Fluorinated Gasses

1. This air-conditioning unit contains fluorinated gasses. For specific information on the type of gas and the amount, please refer to the relevant label on the unit itself.
2. Installation, service, maintenance and repair of this unit must be performed by a certified technician.
3. Product uninstallation and recycling must be performed by a certified technician.
4. If the system has a leak-detection system installed, it must be checked for leaks at least every 12 months.
5. When the unit is checked for leaks, proper record-keeping of all checks is strongly recommended.

Explanation of symbols displayed on the indoor unit or outdoor unit
(applicable to the unit adopts R32/R290 Refrigerant only):

	WARNING	This symbol shows that this appliance uses a flammable refrigerant. If the refrigerant is leaked and exposed to an external ignition source, there is a risk of fire.
	CAUTION	This symbol shows that the operation manual should be read carefully.
	CAUTION	This symbol shows that a service personnel should be handling this equipment with reference to the installation manual.
	CAUTION	
	CAUTION	This symbol shows that information is available such as the operating manual or installation manual.

Installation Overview

3

INSTALLATION ORDER

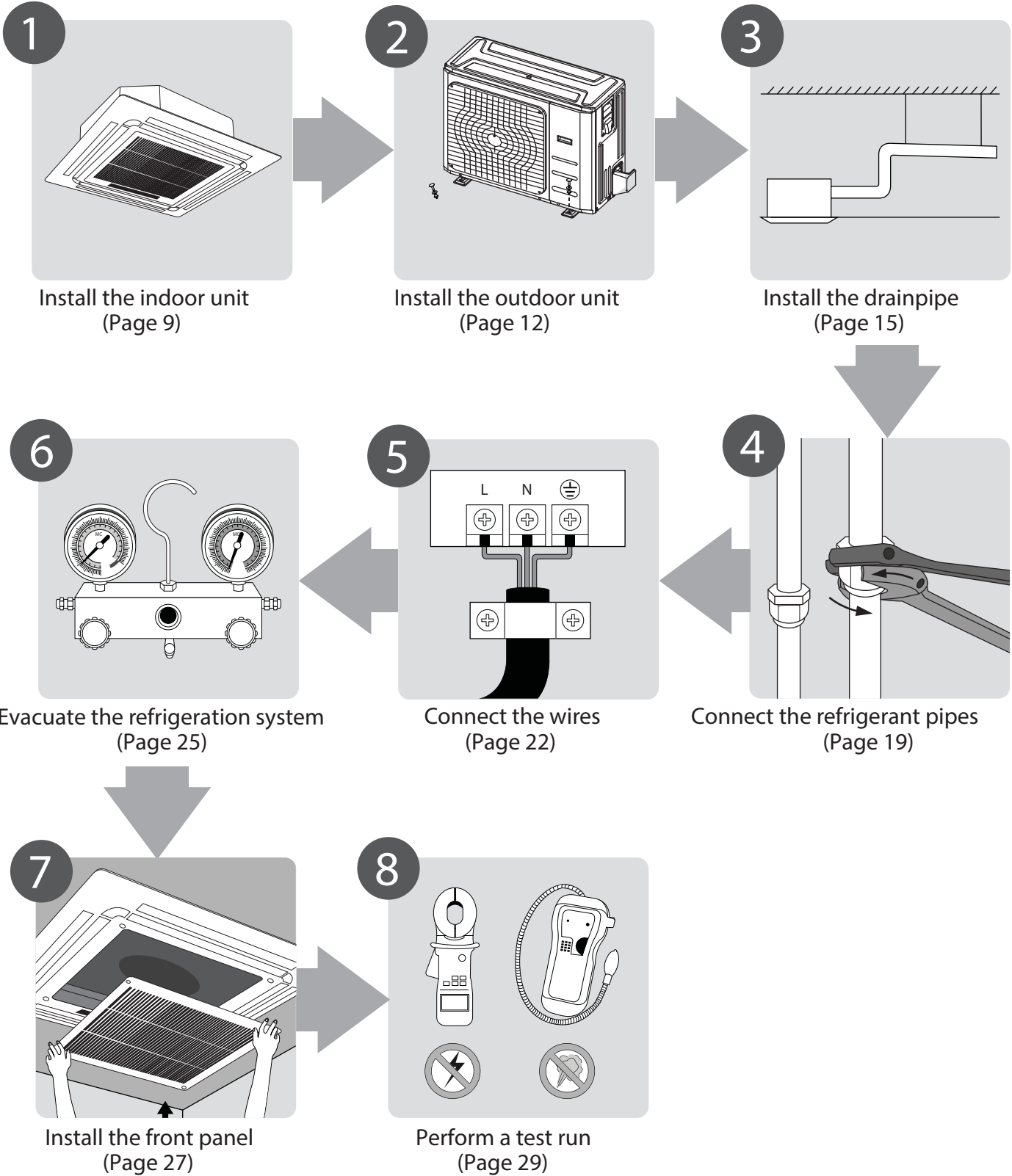

Indoor Unit Installation

4

Indoor Unit Parts

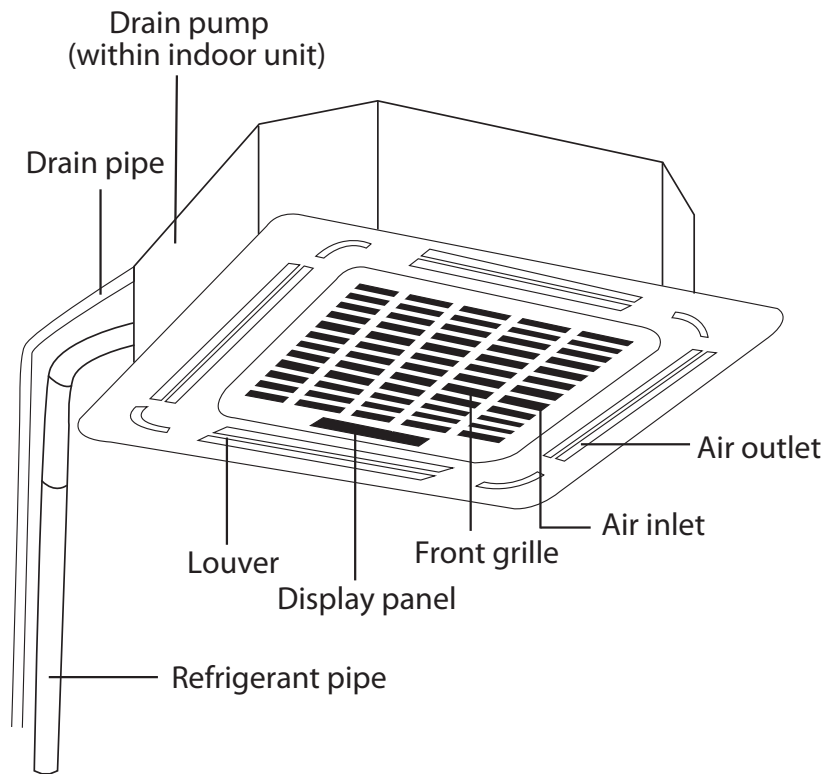

Fig. 4.1

Safety Precautions

⚠ WARNING

- Securely install the indoor unit on a structure that can sustain its weight. If the structure is too weak, the unit may fall and cause personal injury, unit and property damage, or death.
- Install the indoor unit at a height of more than 2.5m (8') above the floor.
- **DO NOT** install the indoor unit in a bathroom or laundry room as excessive moisture can short the unit and corrode the wiring.

⚠ CAUTION

- Install the indoor and outdoor units, cables, and wires at least 1m (3.2') from televisions and radios to prevent static or image distortion. Depending on the appliances, a 1m (3.2') distance may not be sufficient.
- If the indoor unit is installed on metal, it must be electrically grounded.

Indoor Unit Installation Instructions

NOTE: Panel installation should be done after piping and wiring.

Step 1: Select installation location

The indoor unit should be installed in a location that meets the following requirements:

- ☑ The unit is at least 1m (39") from the nearest wall.
- ☑ There is enough room for installation and maintenance.
- ☑ There is enough room for the connecting pipe and drainpipe.
- ☑ The ceiling is horizontal and its structure can sustain the weight of the indoor unit.
- ☑ The air inlet and outlet are not impeded.
- ☑ The airflow can fill the entire room.
- ☑ There is no direct radiation from heaters.

! CAUTION

DO NOT install the unit in the following locations:

- ⊘ In areas with oil drilling or fracking
- ⊘ In coastal areas with high salt content in the air
- ⊘ In areas with caustic gases in the air, such as near hot springs
- ⊘ In areas with power fluctuations, such as factories
- ⊘ In enclosed spaces, such as cabinets
- ⊘ In kitchens that use natural gas
- ⊘ In areas with strong electromagnetic waves
- ⊘ In areas that store flammable materials or gas
- ⊘ In rooms with high humidity, such as bathrooms or laundry rooms

RECOMMENDED DISTANCES BETWEEN THE INDOOR UNIT AND THE CEILING

The distance between the mounted indoor unit and the internal ceiling should meet the following specifications. (See Fig. 4.2)

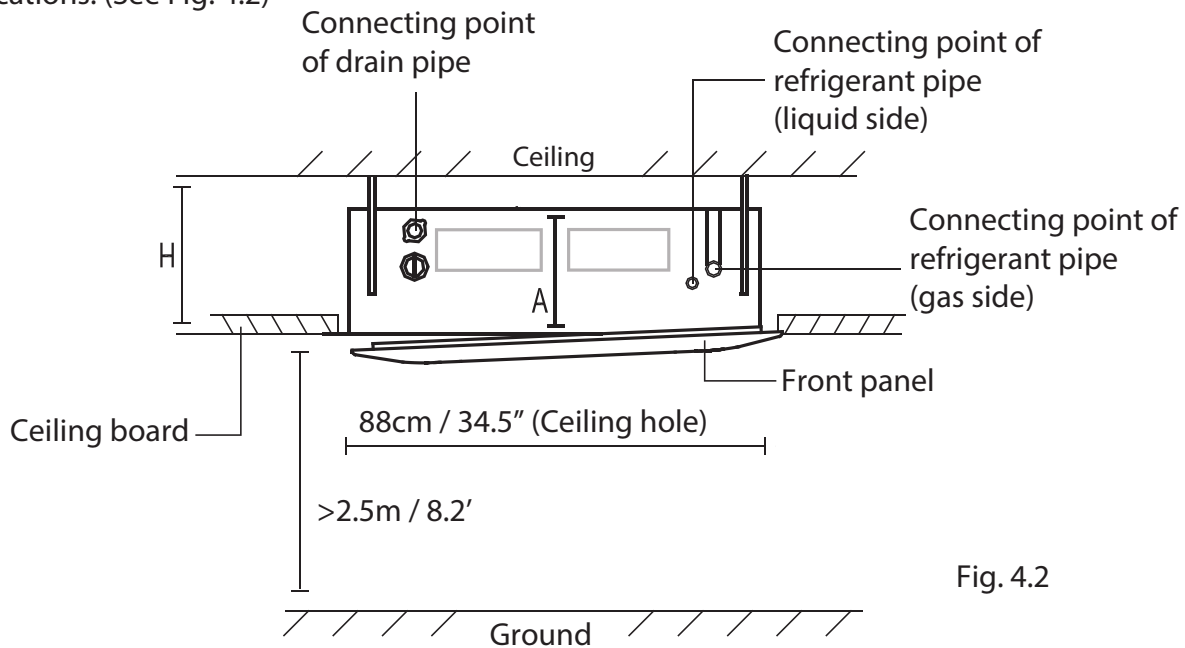

Fig. 4.2

Table 4.1: Distance from ceiling relative to height of indoor unit

MODEL	Length of A (mm/inch)	Length of H (mm/inch)
70M	205/8	> 235/9.3
105M	245/9.6	> 275/10.8
140M/160M	287/11.3	> 317/12.5

Step 2: Hang indoor unit.

1. Use the included paper template to cut a rectangular hole in the ceiling, leaving at least 1m (39") on all sides. The cut hole size should be 4cm(1.6") larger than the body size(See Fig. 4.3). Be sure to mark the areas where ceiling hook holes will be drilled.

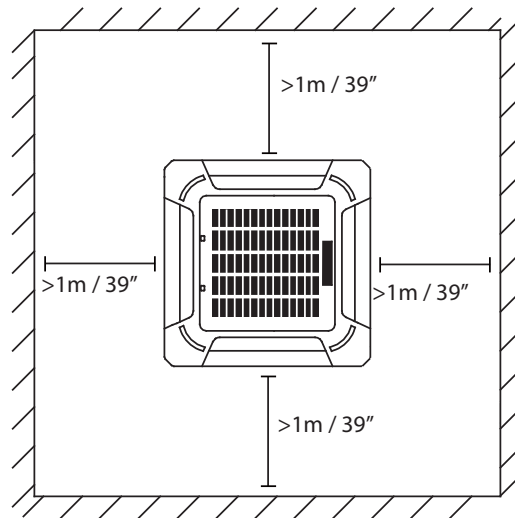
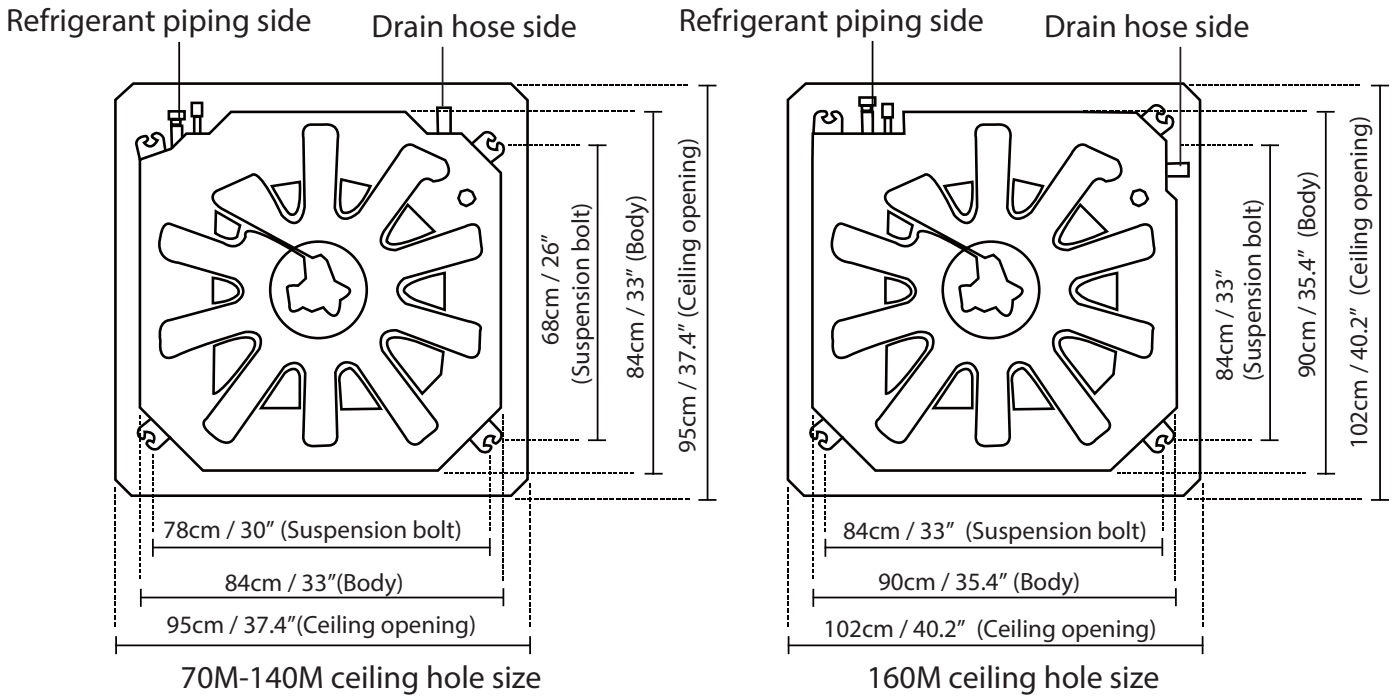

Fig. 4.3

CAUTION

The unit body should align perfectly with the hole. Ensure that the unit and the hole are the same size before moving on.

2. Drill 4 holes 5cm (2") deep at the ceiling hook positions in the internal ceiling. Be sure to hold the drill at a 90° angle to the ceiling.
3. Using a hammer, insert the ceiling hooks into the pre-drilled holes. Secure the bolt using the included washers and nuts.
4. Install the four suspension bolts (See Fig. 4.4).

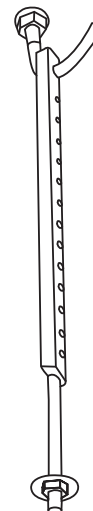

Fig. 4.4

5. Mount the indoor unit. You will need two people to lift and secure it. Insert suspension bolts into the unit's hanging holes. Fasten them using the included washers and nuts (See Fig. 4.5).

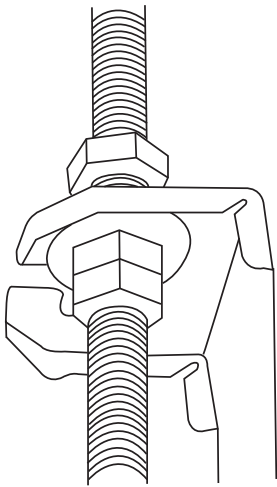

Fig. 4.5

NOTE: The bottom of the unit should be 10 - 18mm (0.4-0.7") higher than the ceiling board. Generally, L (indicated in Fig. 4.6) should be half the length of the suspension bolt or long enough to prevent the nuts from coming off.

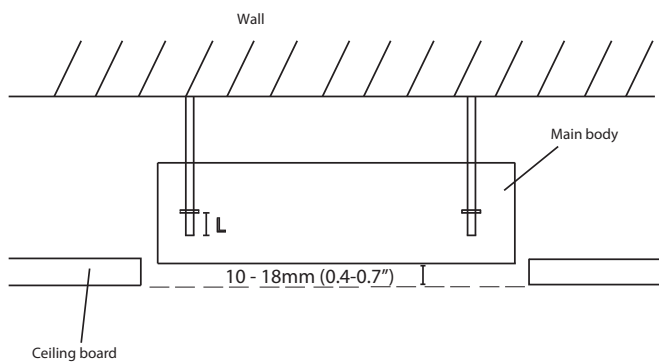

Fig. 4.6

! CAUTION

Ensure that the unit is completely level. Improper installation can cause the drain pipe to back up into the unit or water leakage.

NOTE: Ensure that the indoor unit is level. The unit is equipped with a built-in drain pump and float switch. If the unit is tilted against the direction of condensate flows (the drainpipe side is raised), the float switch may malfunction and cause water to leak.

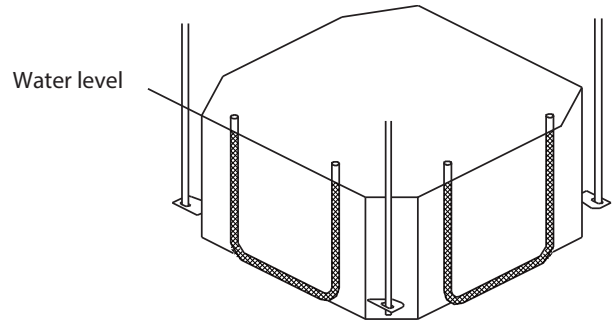

Fig. 4.7

NOTE FOR NEW HOME INSTALLATION

When installing the unit in a new home, the ceiling hooks can be embedded in advance. Make sure that the hooks do not come loose due to concrete shrinkage. After installing the indoor unit, fasten the installation paper template onto the unit with bolts (M6X12) to determine in advance the dimension and position of the opening on the ceiling. Follow the instructions above for the remainder of the installation.

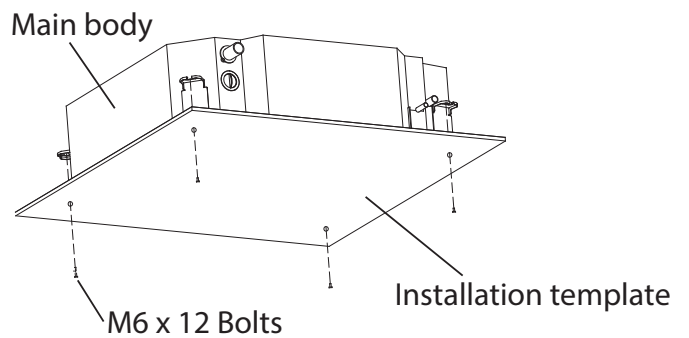

Fig. 4.8

Outdoor Unit Installation (LIGHT Commercial system)

Outdoor Unit Installation Instructions

Step 1: Select installation location.

The outdoor unit should be installed in the location that meets the following requirements:

- ☑ Place the outdoor unit as close to the indoor unit as possible.
- ☑ Ensure that there is enough room for installation and maintenance.
- ☑ The air inlet and outlet must not be obstructed or exposed to strong wind.
- ☑ Ensure the location of the unit will not be subject to snowdrifts, accumulation of leaves or other seasonal debris. If possible, provide a canopy for the unit. Ensure that the canopy does not obstruct the airflow.
- ☑ The installation area must be dry and well ventilated.
- ☑ There must be enough room to install the connecting pipes and cables and to access them for maintenance.

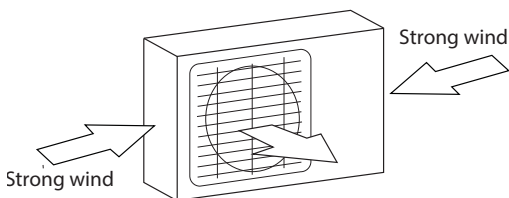

Fig. 5.1

- ☑ The area must be free of combustible gases and chemicals.
- ☑ The pipe length between the outdoor and indoor unit may not exceed the maximum allowable pipe length.
- ☑ If possible, DO NOT install the unit where it is exposed to direct sunlight.
- ☑ If possible, make sure the unit is located far away from your neighbors' property so that the noise from the unit will not disturb them.
- ☑ If the location is exposed to strong winds (for example: near a seaside), the unit must be placed against the wall to shelter it from the wind. If necessary, use a windbreak (or similar). (See Fig. 5.1 & 5.2)
- ☑ Install the indoor and outdoor units, cables and wires at least 1 meter from televisions or radios to prevent static or image distortion. Depending on the radio waves, a 1 meter distance may not be enough to eliminate all interference.

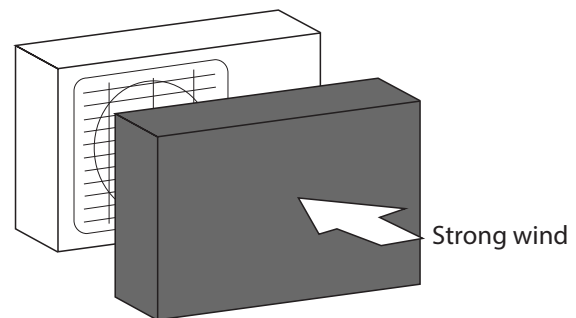

Fig. 5.2

Step 2: Install outdoor unit.

Fix the outdoor unit with anchor bolts (M10)

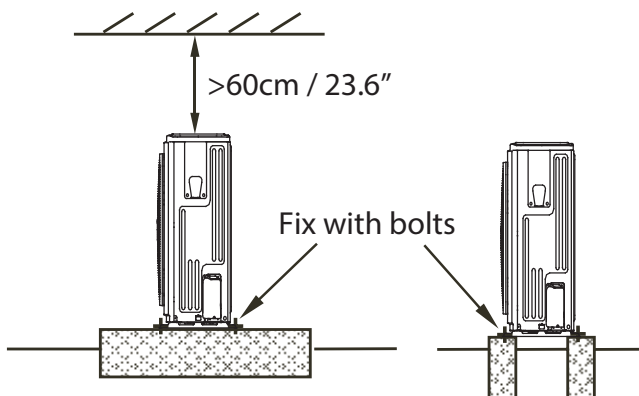

Fig. 5.3

! CAUTION

- Be sure to remove any obstacles that may block air circulation.
- Make sure you refer to Length Specifications to ensure there is enough room for installation and maintenance.

Split Type Outdoor Unit

(Refer to Fig 5.4, 5.5, 5.6, 5.7 and Table 5.1)

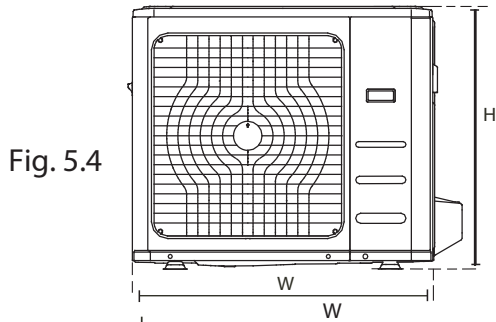

Fig. 5.4

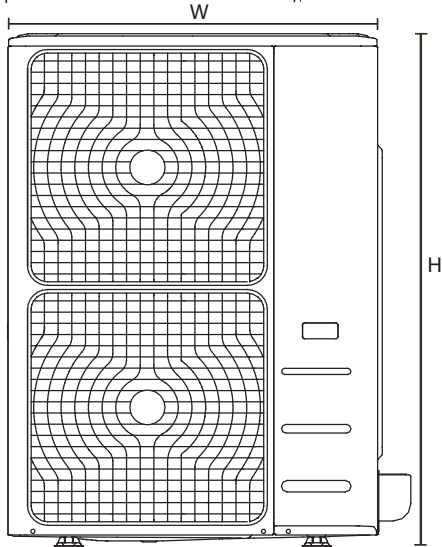

Fig. 5.5

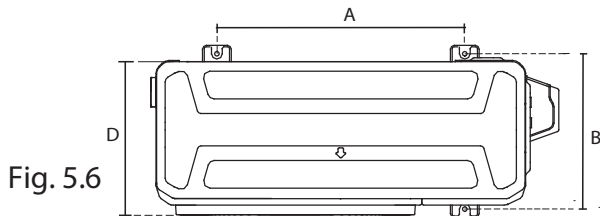

Fig. 5.6

Table 5.1: Length Specifications of Split Type Outdoor Unit (unit: mm/inch)

Outdoor Unit (unit: mm/inch)

Size	Outdoor Unit Dimensions	Mounting Dimensions	
	W x H x D	Distance A	Distance B
70M	845x702x363 (33.27x27.6x14.3)	540 (21.26)	350 (13.8)
105M/105T	946x810x410 (37.24x31.9x16.14)	673 (26.5)	403 (15.87)
140T/160T	952x1333x415 (37.5x52.5x16.34)	634 (24.96)	404 (15.9)

NOTE: The minimum distance between the outdoor unit and walls described in the installation guide does not apply to airtight rooms. Be sure to keep the unit unobstructed in at least two of the three directions (M, N, P) (See Fig. 5.7)

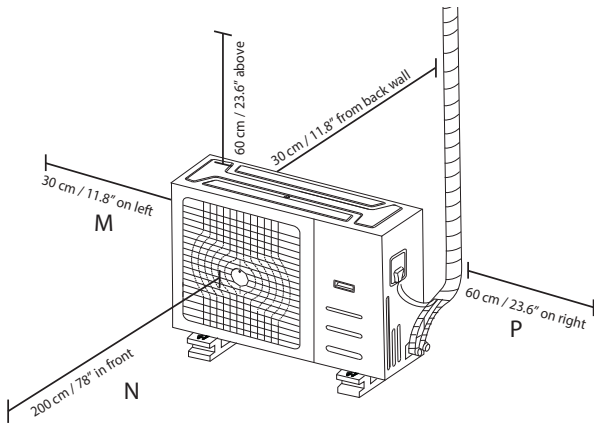

Fig. 5.7

Rows of series installation

Table 5.3 The relations between H, A and L are as follows.

	L	A
L ≤ H	L ≤ 1/2H	25 cm / 9.8" or more
	1/2H < L ≤ H	30 cm / 11.8" or more
L > H	Can not be installed	

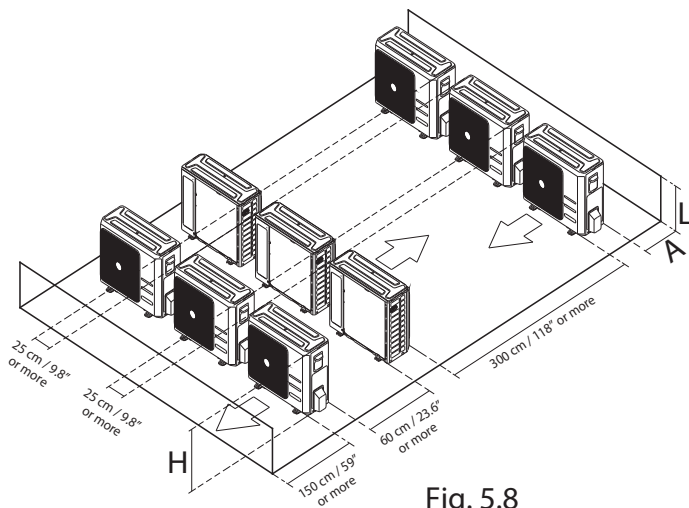

Fig. 5.8

Drain Joint Installation

If the drain joint comes with a rubber seal (see Fig. 5.9 - A), do the following:

1. Fit the rubber seal on the end of the drain joint that will connect to the outdoor unit.

2. Insert the drain joint into the hole in the base pan of the unit.
3. Rotate the drain joint 90° until it clicks in place and faces the front of the unit.
4. Connect a drain hose extension (not included) to the drain joint to redirect water from the unit during heating mode.

If the drain joint doesn't come with a rubber seal (see Fig. 5.9 - B), do the following:

1. Insert the drain joint into the hole in the base pan of the unit. The drain joint will click in place.
2. Connect a drain hose extension (not included) to the drain joint to redirect water from the unit during heating mode.

NOTE: Make sure the water drains to a safe location where it will not cause water damage or a slipping hazard.

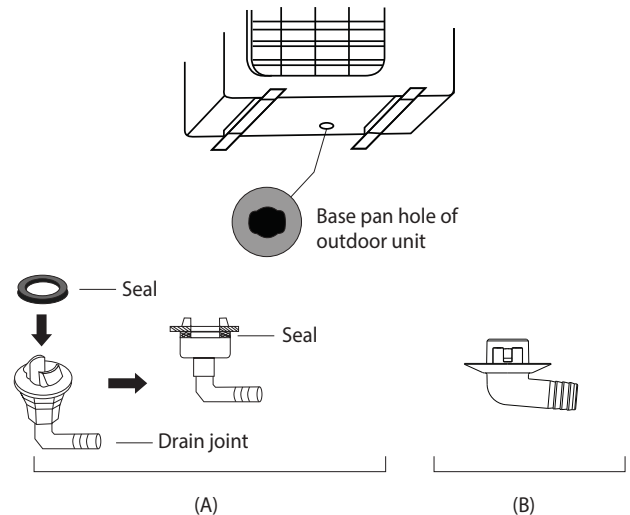

Fig. 5.9

Notes On Drilling Hole In Wall

You must drill a hole in the wall for the refrigerant piping, and the signal cable that will connect the indoor and outdoor units.

1. Determine the location of the wall hole based on the location of the outdoor unit.
2. Using a 65-mm (2.5") core drill, drill a hole in the wall.

NOTE: When drilling the wall hole, make sure to avoid wires, plumbing, and other sensitive components.

3. Place the protective wall cuff in the hole. This protects the edges of the hole and will help seal it when you finish the installation process.

Drainpipe Installation

6

The drainpipe is used to drain water from the unit. Improper installation may cause unit and property damage.

! CAUTION

- Insulate all piping to prevent condensation, which could lead to water damage.
- If the drainpipe is bent or installed incorrectly, water may leak and cause a malfunction of the water-level switch.
- In HEAT mode, the outdoor unit will discharge water. Ensure that the drain hose is placed in an appropriate area to avoid water damage and slippage due to frozen drain water.
- **DO NOT** pull the drainpipe forcefully as this could cause it to disconnect.

NOTE ON PURCHASING PIPES

This installation requires a polyethylene tube (outside diameter = 3.7-3.9cm, inside diameter = 3.2cm), which can be obtained at your local hardware store or from your dealer.

Indoor Drainpipe Installation

Install the drainpipe as shown in Figure 6.2.

1. Cover the drainpipe with heat insulation to prevent condensation and leakage.
2. Attach the mouth of the drain hose to the unit's outlet pipe. Sheath the mouth of the hose and clip it firmly with a pipe clamp. (Fig 6.1)

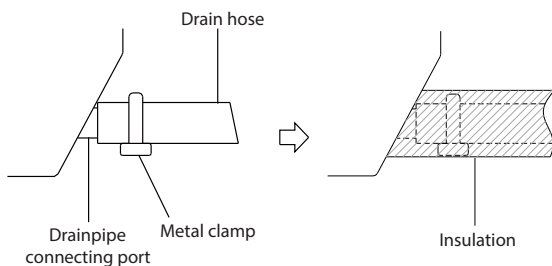

Fig. 6.1

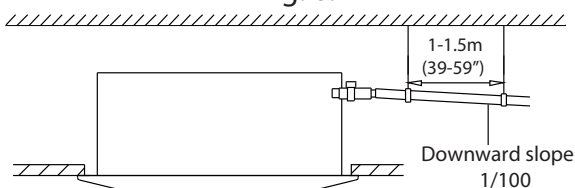

Fig. 6.2

NOTE ON DRAINPIPE INSTALLATION

- When using an extended drainpipe, tighten the indoor connection with an additional protection tube to prevent it from pulling loose.
- The drainpipe should slope downward at a gradient of at least 1/100 to prevent water from flowing back into the air conditioner.
- To prevent the pipe from sagging, space hanging wires every 1-1.5m (40-59").
- If the outlet of the drainpipe is higher than the body's pump joint, provide a lift pipe for the exhaust outlet of the indoor unit. The lift pipe must be installed no higher than 75cm (29.5") from the ceiling board and the distance between the unit and the lift pipe must be less than 30cm (11.8"). Incorrect installation could cause water to flow back into the unit and flood.
- To prevent air bubbles, keep the drain hose level or slightly tilted up (<75mm / 3").

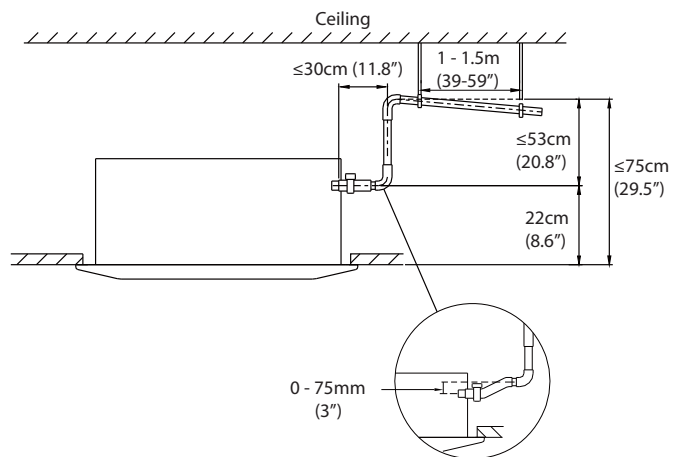

Fig. 6.3

NOTE: When connecting multiple drainpipes, install the pipes as shown in Fig 6.4.

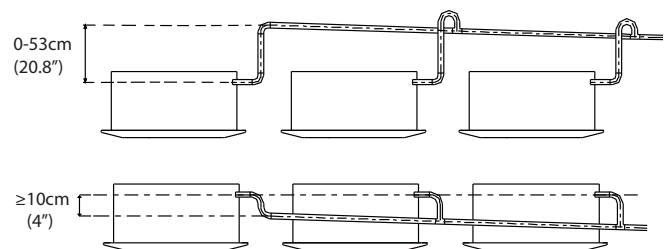

Fig. 6.4

- Using a 65-mm (2.5") core drill, drill a hole in the wall. Make sure that the hole is drilled at a slight downward angle, so that the outdoor end of the hole is lower than the indoor end by about 12mm (0.5"). This will ensure proper water drainage (See Fig. 6.5). Place the protective wall cuff in the hole. This protects the edges of the hole and will help seal it when you finish the installation process.

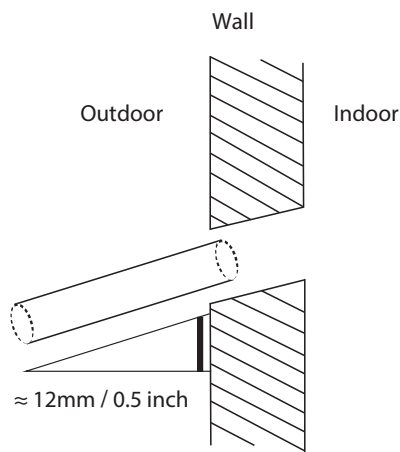

Fig. 6.5

NOTE: When drilling the wall hole, make sure to avoid wires, plumbing, and other sensitive components.

- Pass the drain hose through the wall hole. Make sure the water drains to a safe location where it will not cause water damage or a slipping hazard.

NOTE: The drainpipe outlet should be at least 5cm (1.9") above the ground. If it touches the ground, the unit may become blocked and malfunction. If you discharge the water directly into a sewer, make sure that the drain has a U or S pipe to catch odors that might otherwise come back into the house.

Refrigerant Piping Connection

7

Safety Precautions

! WARNING

- All field piping must be completed by a licensed technician and must comply with the local and national regulations.
- When the air conditioner is installed in a small room, measures must be taken to prevent the refrigerant concentration in the room from exceeding the safety limit in the event of refrigerant leakage. If the refrigerant leaks and its concentration exceeds its proper limit, hazards due to lack of oxygen may result.
- When installing the refrigeration system, ensure that air, dust, moisture or foreign substances do not enter the refrigerant circuit. Contamination in the system may cause poor operating capacity, high pressure in the refrigeration cycle, explosion or injury.
- Ventilate the area immediately if there is refrigerant leakage during the installation. Leaked refrigerant gas is both toxic and flammable. Ensure there is no refrigerant leakage after completing the installation work.

Notes On Pipe Length and Elevation

Ensure that the length of the refrigerant pipe, the number of bends, and the drop height between the indoor and outdoor units meets the requirements shown in Table 7.1:

Table 7.1: The Maximum Length And Drop Height Based on Models. (Unit: m/ft.)

Type of model	Capacity (Btu/h)	Length of piping	Maximum drop height
North America, Australia and the eu frequency conversion Split Type	<15K	25/82	10/32.8
	≥15K - <24K	30/98.4	20/65.6
	≥24K - <36K	50/164	25/82
	≥36K - ≤60K	65/213	30/98.4

! CAUTION

Mark the data plate with the Orifice installed(for some models).

- Please purchase the fittings according to the requirements in the manual strictly.
- Refer the diagram when installing.(See Fig. 7.2)

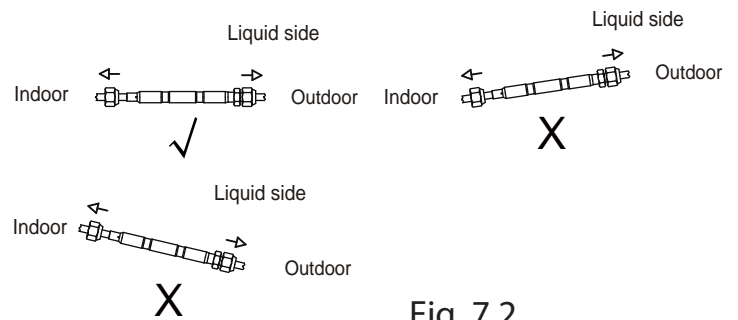

Fig. 7.2

Refrigerant Piping with Twin Indoor Units
When installing multiple indoor units to a single outdoor unit, ensure that the length of the refrigerant pipe and the drop height between the indoor and outdoor units meets the following requirements:

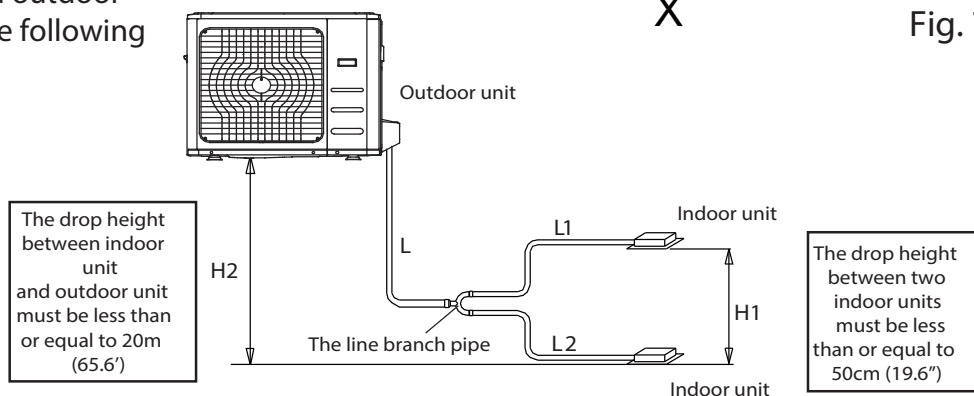

Fig. 7.1

! CAUTION

• Oil traps

If the indoor unit is installed higher than the outdoor unit:

-If oil flows back into the outdoor unit's compressor, this might cause liquid compression or deterioration of oil return. Oil traps in the rising gas piping can prevent this.

An oil trap should be installed every 10m (32.8ft) of vertical suction line riser. (See Fig. 7.3)

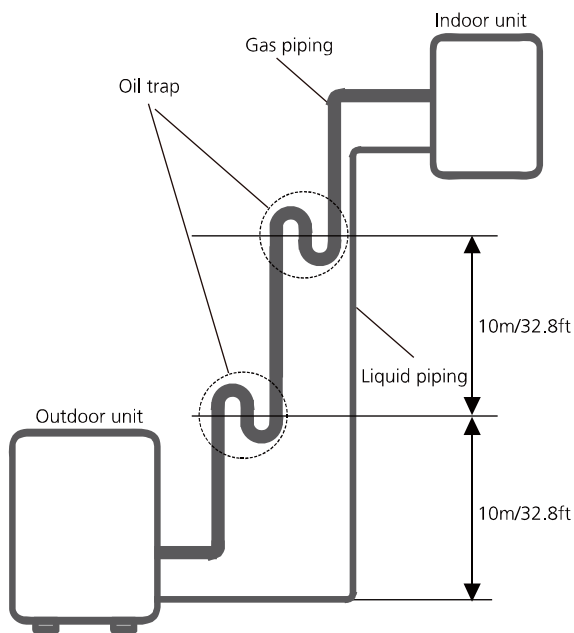

Fig. 7.3

The indoor unit is installed higher than the outdoor unit

! CAUTION

If the outdoor unit is installed higher than the indoor unit:

-It is recommended that vertical suction risers not be upsized. Proper oil return to the compressor should be maintained with suction gas velocity. If velocities drop below 7.62m/s (1500fpm (feet per minute)), oil return will be decreased. An oil trap should be installed every 6m(20ft) of vertical suction line riser. (See Fig. 7.4)

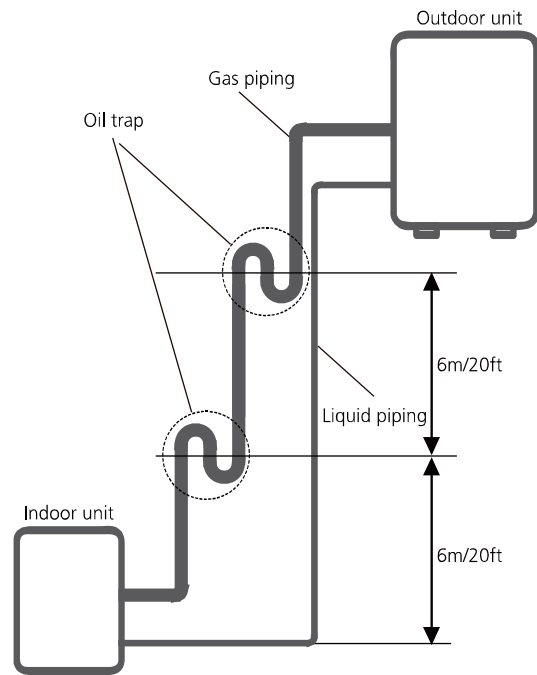

Fig. 7.4

The outdoor unit is installed higher than the indoor unit

Table 7.2

Permitted length				
Piping length	Total piping length	24K+24K 30K+30K	50/164'	L+Max (L1, L2)
	(farthest distance from the line pipe branch)		15/49'	L1, L2
	(farthest distance from the line pipe branch)		10/32.8'	L1-L2
Drop height	Drop height between indoor and outdoor unit		20/65.6'	H1
	Drop height between two indoor units		0.5/1.6'	H2

Refrigerant Piping Connection Instructions

! CAUTION

- The branching pipe must be installed horizontally. An angle of more than 10° may cause malfunction.
- **DO NOT** install the connecting pipe until both indoor and outdoor units have been installed.
- Insulate both the gas and liquid piping to prevent water leakage.

Step1: Cut pipes

When preparing refrigerant pipes, take extra care to cut and flare them properly. This will ensure efficient operation and minimize the need for future maintenance.

1. Measure the distance between the indoor and outdoor units.
2. Using a pipe cutter, cut the pipe a little longer than the measured distance.

! CAUTION

DO NOT deform pipe while cutting. Be extra careful not to damage, dent, or deform the pipe while cutting. This will drastically reduce the heating efficiency of the unit.

1. Make sure that the pipe is cut at a perfect 90° angle. Refer to Fig. 7.5 for examples of bad cuts

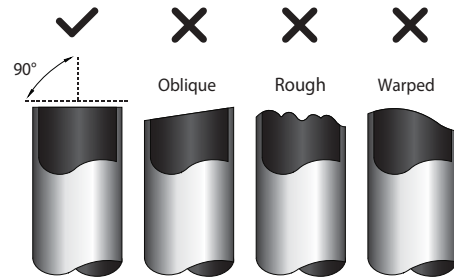

Fig. 7.5

Step 2: Remove burrs.

Burrs can affect the air-tight seal of refrigerant piping connection. They must be completely removed.

1. Hold the pipe at a downward angle to prevent burrs from falling into the pipe.
2. Using a reamer or deburring tool, remove all burrs from the cut section of the pipe.

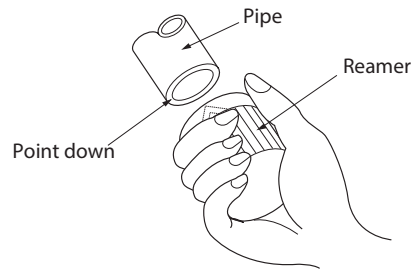

Fig. 7.6

Step 3: Flare pipe ends

Proper flaring is essential to achieve an airtight seal.

1. After removing burrs from cut pipe, seal the ends with PVC tape to prevent foreign materials from entering the pipe.
2. Sheath the pipe with insulating material.
3. Place flare nuts on both ends of pipe. Make sure they are facing in the right direction, because you can't put them on or change their direction after flaring. See Fig. 7.7

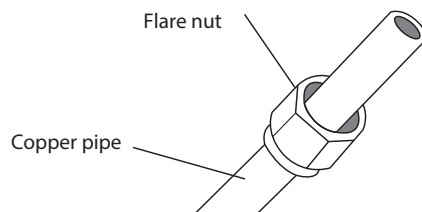

Fig. 7.7

- Remove PVC tape from ends of pipe when ready to perform flaring work.
- Clamp flare form on the end of the pipe. The end of the pipe must extend beyond the flare form.

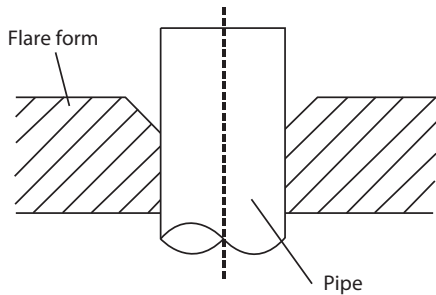

Fig. 7.8

- Place flaring tool onto the form.
- Turn the handle of the flaring tool clockwise until the pipe is fully flared. Flare the pipe in accordance with the dimensions shown in table 7.3.

Table 7.3: PIPING EXTENSION BEYOND FLARE FORM

Pipe gauge	Tightening torque (Unit: mm/Inch)	Flare dimension (A) (Unit: mm/Inch)		Flare shape
		Min.	Max .	
Ø 6.4	18-20N.m (183-204kgf.cm)	8.4/0.33	8.7/0.34	
Ø 9.5	25-26 N.m (255-265 kgf.cm)	13.2/0.52	13.5/0.53	
Ø 12.7	35-36 N.m (357-367 kgf.cm)	16.2/0.64	16.5/0.65	
Ø 15.9	45-47 N.m (459-480 kgf.cm)	19.2/0.76	19.7/0.78	
Ø 19.1	65-67 N.m (663-683 kgf.cm)	23.2/0.91	23.7/0.93	
Ø 22	75-85N.m (765-867 kgf.cm)	26.4/1.04	26.9/1.06	

Fig. 7.9

- Remove the flaring tool and flare form, then inspect the end of the pipe for cracks and even flaring.

Step 4: Connect pipes

Connect the copper pipes to the indoor unit first, then connect it to the outdoor unit. You should first connect the low-pressure pipe, then the high-pressure pipe.

- When connecting the flare nuts, apply a thin coat of refrigeration oil to the flared ends of the pipes.
- Align the center of the two pipes that you will connect.

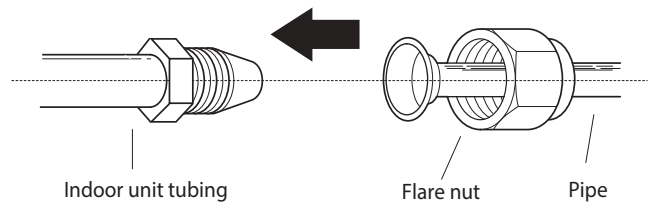

Fig. 7.10

- Tighten the flare nut as tightly as possible by hand.
- Using a spanner, grip the nut on the unit tubing.
- While firmly gripping the nut, use a torque wrench to tighten the flare nut according to the torque values in table 7.3.

NOTE: Use both a spanner and a torque wrench when connecting or disconnecting pipes to/from the unit.

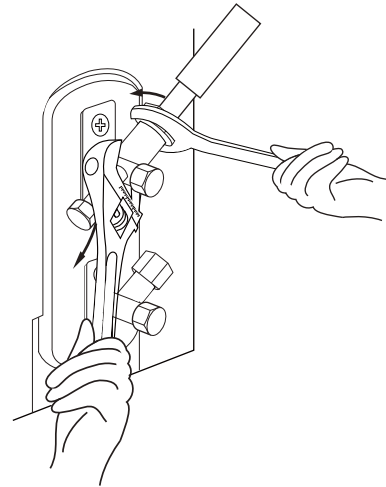

Fig. 7.11

! CAUTION

- Ensure to wrap insulation around the piping. Direct contact with the bare piping may result in burns or frostbite.
- Make sure the pipe is properly connected. Over tightening may damage the bell mouth and under tightening may lead to leakage.

NOTE ON MINIMUM BEND RADIUS

Carefully bend the tubing in the middle according to the diagram below. DO NOT bend the tubing more than 90° or more than 3 times.

Bend the pipe with thumb

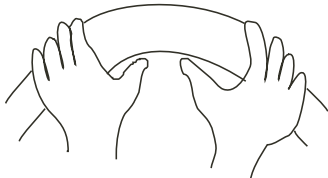

min-radius 10cm (3.9")

Fig. 7.12

6. After connecting the copper pipes to the indoor unit, wrap the power cable, signal cable and the piping together with binding tape.

NOTE: DO NOT intertwine signal cable with other wires. While bundling these items together, do not intertwine or cross the signal cable with any other wiring.

7. Thread this pipeline through the wall and connect it to the outdoor unit.
8. Insulate all the piping, including the valves of the outdoor unit.
9. Open the stop valves of the outdoor unit to start the flow of the refrigerant between the indoor and outdoor unit.

CAUTION

Check to make sure there is no refrigerant leak after completing the installation work. If there is a refrigerant leak, ventilate the area immediately and evacuate the system (refer to the Air Evacuation section of this manual).

Safety Precautions

WARNING

- Be sure to disconnect the power supply before working on the unit.
- All electrical wiring must be done according to local and national regulations.
- Electrical wiring must be done by a qualified technician. Improper connections may cause electrical malfunction, injury and fire.
- An independent circuit and single outlet must be used for this unit. **DO NOT** plug another appliance or charger into the same outlet. If the electrical circuit capacity is not enough or there is a defect in the electrical work, it can lead to shock, fire, unit and property damage.
- Connect the power cable to the terminals and fasten it with a clamp. An insecure connection may cause fire.
- Make sure that all wiring is done correctly and the control board cover is properly installed. Failure to do so can cause overheating at the connection points, fire, and electrical shock.
- The power supply line must have upstream to appropriate protection against short circuits and earth faults that section the system with respect to other users.
- **DO NOT** modify the length of the power cord or use an extension cord.

CAUTION

- Connect the outdoor wires before connecting the indoor wires.
- Make sure you ground the unit. The grounding wire should be away from gas pipes, water pipes, lightning rods, telephone or other grounding wires. Improper grounding may cause electrical shock.
- **DO NOT** connect the unit with the power source until all wiring and piping is completed.
- Make sure that you do not cross your electrical wiring with your signal wiring, as this can cause distortion and interference.

Follow these instructions to prevent distortion when the compressor starts:

- The unit must be connected to the main outlet. Normally, the power supply must have a low output impedance of 32 ohms.
- No other equipment should be connected to the same power circuit.
- The unit's power information can be found on the rating sticker on the product.

TAKE NOTE OF FUSE SPECIFICATIONS

The air conditioner's circuit board (PCB) is designed with a fuse to provide overcurrent protection. The specifications of the fuse are printed on the circuit board, such as:
 Indoor unit: T3.15A/250VAC, T5A/250VAC.
 (applicable for unit adopts R32 or R290 r efrigerant only)
 Outdoor unit: T20A/250VAC(for <24000Btu/h unit), T30A/250VAC(for >24000Btu/h unit)

NOTE: The fuse is made of ceramic.

Outdoor Unit Wiring

WARNING

Before performing any electrical or wiring work, turn off the main power to the system.

1. Prepare the cable for connection
 - a. You must first choose the right cable size before preparing it for connection. Be sure to use H07RN-F cables.

Table 8.1: Minimum Cross-Sectional Area of Power and Signal Cables North America

Absorbed maximum (A)	AWG
≤7	18
7 - 13	16
13 - 18	14
18 - 25	12
25 - 30	10

Table 8.2: Other Regions

Absorbed maximum (A)	Nominal Cross-Sectional Area (mm ²)
≤6	0.75
6 - 10	1
10 - 16	1.5
16 - 25	2.5
25 - 32	4
32 - 45	6

- b. Using wire strippers, strip the rubber jacket from both ends of signal cable to reveal about 15cm (5.9") of the wires inside.
- c. Strip the insulation from the ends of the wires.
- d. Using a wire crimper, crimp u-lugs on the ends of the wires.

NOTE: While connecting the wires, please strictly follow the wiring diagram (found inside the electrical box cover).

2. Remove the electric cover of the outdoor unit. If there is no cover on the outdoor unit, disassemble the bolts from the maintenance board and remove the protection board. (See Fig. 8.1)

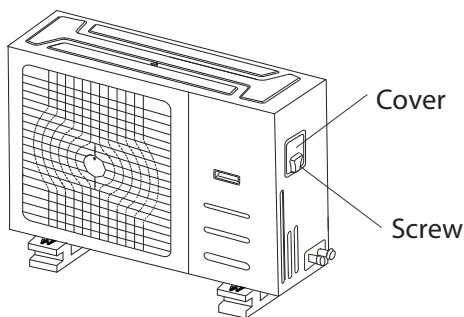

Fig. 8.1

3. Connect the u-lugs to the terminals. Match the wire colors/labels with the labels on the terminal block, and firmly screw the u-lug of each wire to its corresponding terminal.
4. Clamp down the cable with designated cable clamp.
5. Insulate unused wires with electrical tape. Keep them away from any electrical or metal parts.
6. Reinstall the cover of the electric control box.

Indoor Unit Wiring

1. Prepare the cable for connection
 - a. Using wire strippers, strip the rubber jacket from both ends of signal cable to reveal about 15cm (5.9") of the wires inside.
 - b. Strip the insulation from the ends of the wires.
 - c. Using wire crimper, crimp the u-lugs to the ends of the wires.
2. Open the front panel of the indoor unit. Using a screwdriver, remove the cover of the electric control box on your indoor unit.
3. Thread the power cable and the signal cable through the wire outlet.

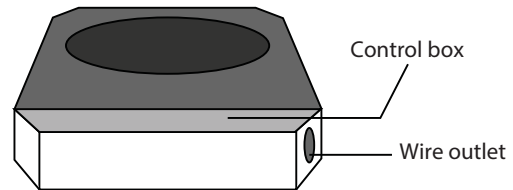

Fig. 8.2

4. Connect the u-lugs to the terminals. Match the wire colors/labels with the labels on the terminal block, and firmly screw the u-lug of each wire to its corresponding terminal. Refer to the Serial Number and Wiring Diagram located on the cover of the electric control box.

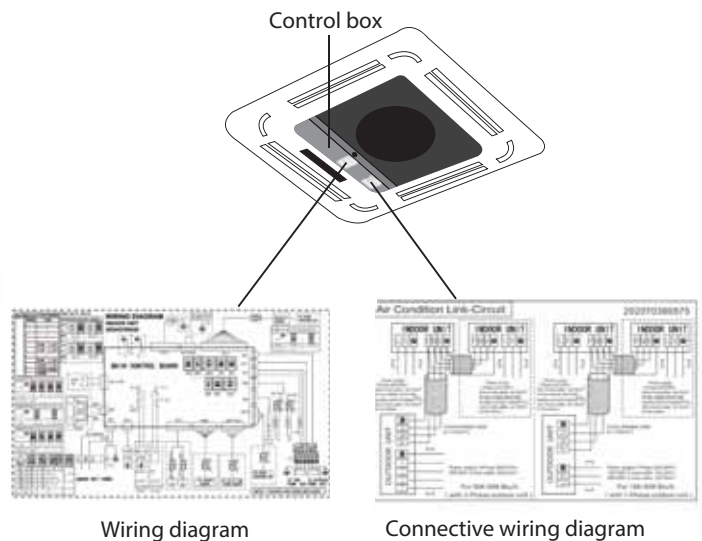

Fig. 8.3

Magnetic ring(if supplied and packed with the accessories)

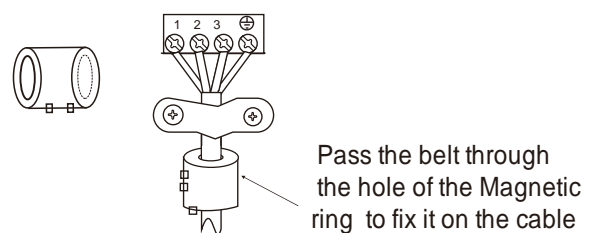

Fig. 8.4

! CAUTION

- While connecting the wires, please strictly follow the wiring diagram.
- The refrigerant circuit can become very hot. Keep the interconnection cable away from the copper tube.

5. Clamp down cable with the designated cable clamp to secure it in place. The cable should not be loose, and should not pull on the u-lugs.
6. Reinstall the electric box cover and the front panel of the indoor unit.

Power Specifications

NOTE: Electric auxiliary heating type circuit breaker/fuse need to add more than 10 A.

Indoor Power Supply Specifications

MODEL(Btu/h)		≤18K	19K~24K	25K~36K	37K~48K	49K~60K
POWER	PHASE	1 Phase	1 Phase	1 Phase	1 Phase	1 Phase
	VOLT	208-240V	208-240V	208-240V	208-240V	208-240V
CIRCUIT BREAKER/ FUSE(A)		25/20	32/25	50/40	70/55	70/60

MODEL(Btu/h)		≤36K	37K~60K	≤36K	37K~60K
POWER	PHASE	3 Phase	3 Phase	3 Phase	3 Phase
	VOLT	380-420V	380-420V	208-240V	208-240V
CIRCUIT BREAKER/FUSE(A)		25/20	32/25	32/25	45/35

Outdoor Power Supply Specifications

MODEL(Btu/h)		≤18K	19K~24K	25K~36K	37K~48K	49K~60K
POWER	PHASE	1 Phase	1 Phase	1 Phase	1 Phase	1 Phase
	VOLT	208-240V	208-240V	208-240V	208-240V	208-240V
CIRCUIT BREAKER/ FUSE(A)		25/20	32/25	50/40	70/55	70/60

MODEL(Btu/h)		≤36K	37K~60K	≤36K	37K~60K
POWER	PHASE	3 Phase	3 Phase	3 Phase	3 Phase
	VOLT	380-420V	380-420V	208-240V	208-240V
CIRCUIT BREAKER/FUSE(A)		25/20	32/25	32/25	45/35

Independent Power Supply Specifications

MODEL(Btu/h)		≤18K	19K~24K	25K~36K	37K~48K	49K~60K
POWER (indoor)	PHASE	1 Phase	1 Phase	1 Phase	1 Phase	1 Phase
	VOLT	208-240V	208-240V	208-240V	208-240V	208-240V
CIRCUIT BREAKER/FUSE(A)		15/10	15/10	15/10	15/10	15/10
POWER (outdoor)	PHASE	1 Phase	1 Phase	1 Phase	1 Phase	1 Phase
	VOLT	208-240V	208-240V	208-240V	208-240V	208-240V
CIRCUIT BREAKER/FUSE(A)		25/20	32/25	50/40	70/55	70/60

MODEL(Btu/h)		≤36K	37K~60K	≤36K	37K~60K
POWER (indoor)	PHASE	1 Phase	1 Phase	1 Phase	1 Phase
	VOLT	208-240V	208-240V	208-240V	208-240V
CIRCUIT BREAKER/FUSE(A)		15/10	15/10	15/10	15/10
POWER (outdoor)	PHASE	3 Phase	3 Phase	3 Phase	3 Phase
	VOLT	380-420V	380-420V	208-240V	208-240V
CIRCUIT BREAKER/FUSE(A)		25/20	32/25	32/25	45/35

Inverter Type A/C Power Specifications

MODEL(Btu/h)		≤18K	19K~24K	25K~36K	37K~48K	49K~60K
POWER (indoor)	PHASE	1 Phase	1 Phase	1 Phase	1 Phase	1 Phase
	VOLT	220-240V	220-240V	220-240V	220-240V	220-240V
CIRCUIT BREAKER/FUSE(A)		15/10	15/10	15/10	15/10	15/10
POWER (outdoor)	PHASE	1 Phase	1 Phase	1 Phase	1 Phase	1 Phase
	VOLT	208-240V	208-240V	208-240V	208-240V	208-240V
CIRCUIT BREAKER/FUSE(A)		25/20	25/20	40/30	50/40	50/40

MODEL(Btu/h)		≤36K	37K~60K	≤36K	37K~60K
POWER (indoor)	PHASE	1 Phase	1 Phase	1 Phase	1 Phase
	VOLT	220-240V	220-240V	220-240V	220-240V
CIRCUIT BREAKER/FUSE(A)		15/10	15/10	15/10	15/10
POWER (outdoor)	PHASE	3 Phase	3 Phase	3 Phase	3 Phase
	VOLT	380-420V	380-420V	208-240V	208-240V
CIRCUIT BREAKER/FUSE(A)		25/20	32/25	32/25	40/30

Safety Precautions

! CAUTION

- Use a vacuum pump with a gauge reading lower than -0.1MPa and an air discharge capacity above 40L/min.
- The outdoor unit does not need vacuuming. **DO NOT** open the outdoor unit's gas and liquid stop valves.
- Ensure that the Compound Meter reads -0.1MPa or below after 2 hours. If after three hours of operation and the gauge reading is still above -0.1MPa, check if there is a gas leak or water inside the pipe. If there is no leakage, perform another evacuation for 1 or 2 hours.
- **DO NOT** use refrigerant gas to evacuate the system.

Evacuation Instructions

Before using manifold gauge and vacuum pump, read their operation manuals to familiarize yourself with how to use them properly.

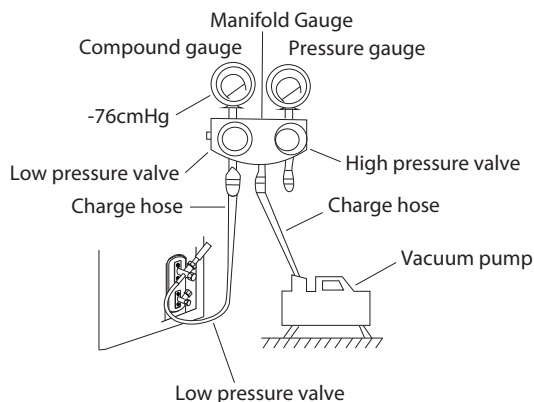

Fig. 9.1

1. Connect the charge hose of the manifold gauge to service port on the outdoor unit's low pressure valve.
2. Connect another charge hose from the manifold gauge to the vacuum pump.
3. Open the Low Pressure side of the manifold gauge. Keep the High Pressure side closed.

4. Turn on the vacuum pump to evacuate the system.
5. Run the vacuum for at least 15 minutes, or until the Compound Meter reads -76cmHG (-1x10⁵Pa).
6. Close the Low Pressure side of the manifold gauge, and turn off the vacuum pump.
7. Wait for 5 minutes, then check that there has been no change in system pressure.

NOTE: If there is no change in system pressure, unscrew the cap from the packed valve (high pressure valve). If there is a change in system pressure, there may be a gas leak.

8. Insert hexagonal wrench into the packed valve (high pressure valve) and open the valve by turning the wrench in a 1/4 counterclockwise turn. Listen for gas to exit the system, then close the valve after 5 seconds.

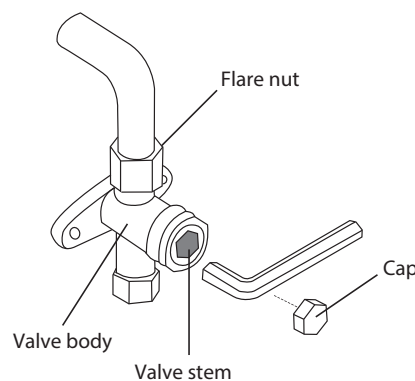

Fig. 9.2

9. Watch the Pressure Gauge for one minute to make sure that there is no change in pressure. The Pressure Gauge should read slightly higher than atmospheric pressure.
10. Remove the charge hose from the service port.
11. Using hexagonal wrench, fully open both the high pressure and low pressure valves.

OPEN VALVE STEMS GENTLY

When opening valve stems, turn the hexagonal wrench until it hits against the stopper. **DO NOT** try to force the valve to open further.

12. Tighten valve caps by hand, then tighten it using the proper tool.

! CAUTION

- Refrigerant charging must be performed after wiring, vacuuming and the leak test.
- **DO NOT** exceed the maximum allowable quantity of refrigerant or overcharge the system. Doing so can damage or impact the unit's function.
- Charging with unsuitable substances may cause explosions or accidents. Ensure that the appropriate refrigerant is used.
- Refrigerant containers must be opened slowly. Always use protective gear when charging the system.
- **DO NOT** mix refrigerants types.
- For the R290 or R32 refrigerant model, make sure the conditions within the area have been made safe by control of flammable material when the refrigerant added into air conditioner.
- The maximum refrigerant charge amount of R32 is 305 grams.

Some systems require additional charging depending on pipe lengths. The standard pipe length varies according to local regulations. For example, in North America, the standard pipe length is 7.5m (25') In other areas, the standard pipe length is 5m (16'). The additional refrigerant to be charged can be calculated using the following formula:

Liquid Side Diameter

	φ6.35(1/4")	φ9.52(3/8")	φ12.7(1/2")
R22 (expansion valve in the indoor unit):	(Total pipe length - standard pipe length)x 30g (0.32oz)/m(ft)	(Total pipe length - standard pipe length)x 65g(0.69oz)/m(ft)	(Total pipe length - standard pipe length)x 115g(1.23oz)/m(ft)
R22 (expansion valve in the outdoor unit):	(Total pipe length - standard pipe length) x15g(0.16oz)/m(ft)	(Total pipe length - standard pipe length) x30(0.32oz)/m(ft)	(Total pipe length - standard pipe length) x60g(0.64oz)/m(ft)
R410A: (expansion valve in the indoor unit):	(Total pipe length - standard pipe length) x30g(0.32oz)/m(ft)	(Total pipe length - standard pipe length) x65g(0.69oz)/m(ft)	(Total pipe length - standard pipe length) x115g(1.23oz)/m(ft)
R410A: (expansion valve in the outdoor unit):	(Total pipe length - standard pipe length) x15g(0.16oz)/m(ft)	(Total pipe length - standard pipe length) x30g(0.32oz)/m(ft)	(Total pipe length - standard pipe length) x65g(0.69oz)/m(ft)
R32 :	(Total pipe length - standard pipe length)x 12g(0.13oz)/m(ft)	(Total pipe length - standard pipe length)x 24g(0.26oz)/m(ft)	(Total pipe length - standard pipe length)x 40g(0.42oz)/m(ft)

Panel Installation

! CAUTION

DO NOT place the panel facedown on the floor, against a wall, or on uneven surfaces.

Step 1: Remove the front grille.

1. Push both of the tabs towards the middle simultaneously to unlock the hook on the grille.
2. Hold the grille at a 45° angle, lift it up slightly and detach it from the main body.

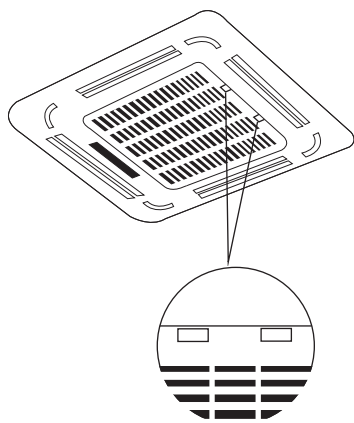

Fig. 10.1

Step 2: Remove the installation covers at the four corners by sliding them outwards.

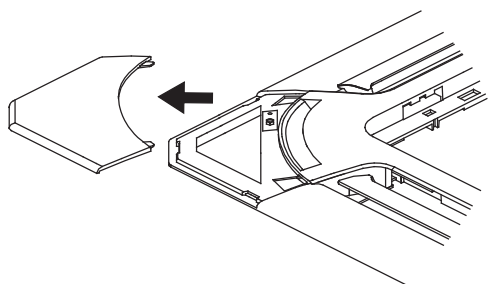

Fig. 10.2

Step 3: Install the panel

Align the front panel to the main body, taking into account the position of the piping and drain sides. Hang the four latches of the decorative panel to the hooks of the indoor unit. Tighten the panel hook screws evenly at the four corners. (See Fig 10.3)

NOTE: Tighten the screws until the thickness of the sponge between the main body and the panel reduces to 4-6mm (0.2-0.3"). The edge of the panel should be in contact with the ceiling well.

Adjust the panel by turning it to the arrowed direction shown in Fig 10.3 so that the ceiling opening is completely covered.

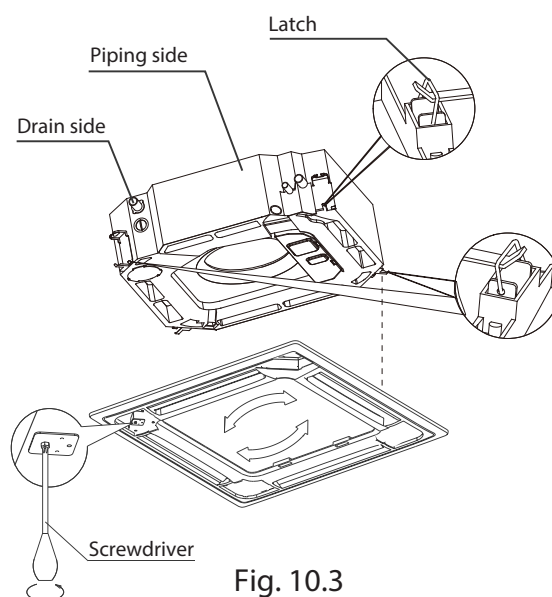

Fig. 10.3

1. Connect the two louver motor connectors to the corresponding wires in the control box.

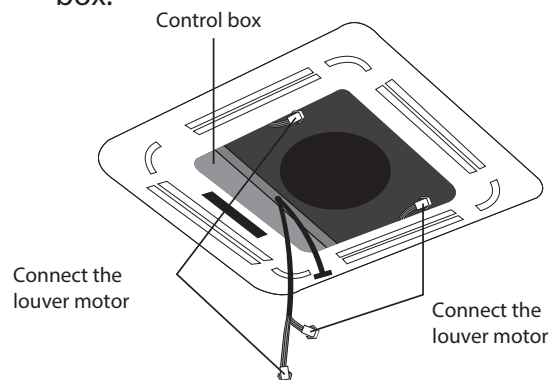

Fig. 10.4

2. Remove foam stops from inside the fan.
3. Attach the side of the front grille to the panel.
4. Connect the display panel cable to the corresponding wire on the main body.

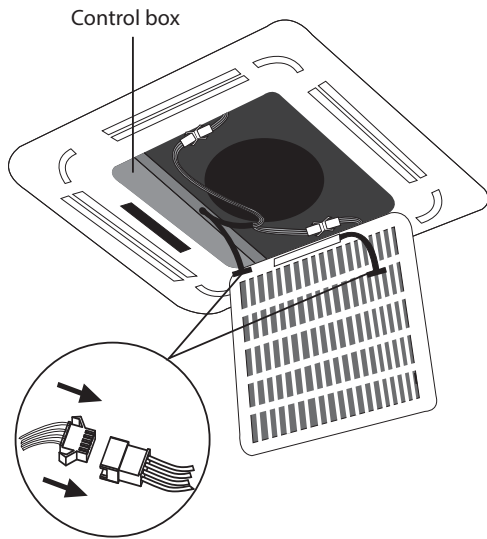

Fig. 10.5

! CAUTION

Failure to tighten screws can cause water leakage.

5. Close the front grille.
6. Fasten the installation covers at all four corners by pushing them inwards. (See Fig.10.6)

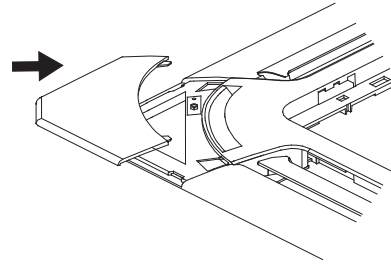

Fig. 10.6

NOTE: If the height of the indoor unit needs to be adjusted, you can do so through the openings at the panel's four corners. Make sure that the internal wiring and drainpipe are not affected by this adjustment.

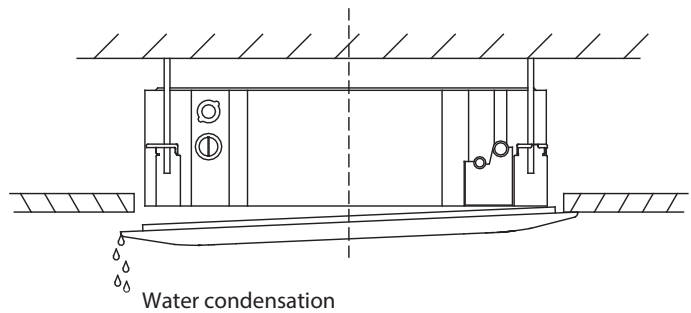

Fig. 10.7

! CAUTION

If the unit is not hung correctly and a gap exists, the unit's height must be adjusted to ensure proper function. The unit's height can be adjusted by loosening the upper nut, and adjusting the lower nut.

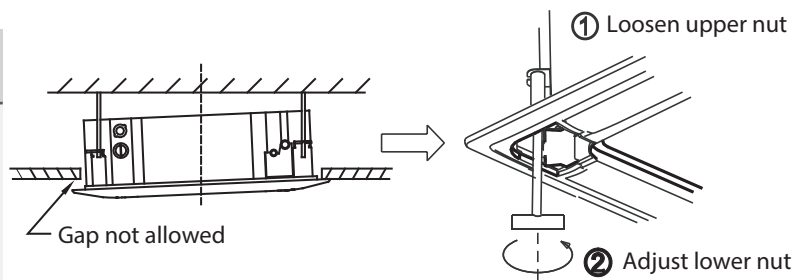

Fig. 10.8

Before Test Run

A test run must be performed after the entire system has been completely installed. Confirm the following points before performing the test:

- a) The indoor and outdoor units are properly installed.
- b) Piping and wiring are properly connected.
- c) Ensure that there are no obstacles near the inlet and outlet of the unit that might cause poor performance or product malfunction.
- d) The refrigeration system does not leak.
- e) The drainage system is unimpeded and draining to a safe location.
- f) The heating insulation is properly installed.
- g) The grounding wires are properly connected.
- h) The length of the piping and the added refrigerant stow capacity have been recorded.
- i) The power voltage is the correct voltage for the air conditioner.

CAUTION

Failure to perform the test run may result in unit damage, property damage or personal injury.

Test Run Instructions

1. Open both the liquid and gas stop valves.
2. Turn on the main power switch and allow the unit to warm up.
3. Set the air conditioner to COOL mode.
4. For the Indoor Unit
 - a. Ensure the remote control and its buttons work properly.
 - b. Ensure the louvers move properly and can be changed using the remote control.
 - c. Double check to see if the room temperature is being registered correctly.
 - d. Ensure the indicators on the remote control and the display panel on the indoor unit work properly.
 - e. Ensure the manual buttons on the indoor unit works properly.

- f. Check to see that the drainage system is unimpeded and draining smoothly.
 - g. Ensure there is no vibration or abnormal noise during operation.
5. For the Outdoor Unit
 - a. Check to see if the refrigeration system is leaking.
 - b. Make sure there is no vibration or abnormal noise during operation.
 - c. Ensure the wind, noise, and water generated by the unit do not disturb your neighbors or pose a safety hazard.
 6. Drainage Test
 - a. Ensure the drainpipe flows smoothly. New buildings should perform this test before finishing the ceiling.
 - b. Remove the test cover. Add 2,000ml of water to the tank through the attached tube.
 - c. Turn on the main power switch and run the air conditioner in COOL mode.
 - d. Listen to the sound of the drain pump to see if it makes any unusual noises.
 - e. Check to see that the water is discharged. It may take up to one minute before the unit begins to drain depending on the drainpipe.
 - f. Make sure that there are no leaks in any of the piping.
 - g. Stop the air conditioner. Turn off the main power switch and reinstall the test cover.

NOTE: If the unit malfunctions or does not operate according to your expectations, please refer to the Troubleshooting section of the Owner's Manual before calling customer service.

The manufacturer is registered on the EEE National Register, in compliance with implementation of Directive 2012/19/EU and relevant national regulations on waste electrical and electronic equipment. This Directive requires electrical and electronic equipment to be disposed of properly.

Equipment bearing the crossed-out wheellie bin mark must be disposed of separately at the end of its life cycle to prevent damage to human health and to the environment.

Electrical and electronic equipment must be disposed of together with all of its parts.

To dispose of "household" electrical and electronic equipment, the manufacturer recommends you contact an authorised dealer or an authorised ecological area.

"Professional" electrical and electronic equipment must be disposed of by authorised personnel through established waste disposal authorities around the country.

In this regard, here is the definition of household WEEE and professional WEEE:

WEEE from private households: WEEE originating from private households and WEEE which comes from commercial, industrial, institutional and other sources which, because of its nature and quantity, is similar to that from private households. Subject to the nature and quantity, where the waste from EEE was likely to have been by both a private household and users of other than private households, it will be classed as private household WEEE;

Professional WEEE: all WEEE which comes from users other than private households.

This equipment may contain:

refrigerant gas, the entire contents of which must be recovered in suitable containers by specialised personnel with the necessary qualifications;

- lubrication oil contained in compressors and in the cooling circuit to be collected;
- mixtures with antifreeze in the water circuit, the contents of which are to be collected;
- mechanical and electrical parts to be separated and disposed of as authorised.

When machine components to be replaced for maintenance purposes are removed or when the entire unit reaches the end of its life and needs to be removed from the installation, waste should be separated by its nature and disposed of by authorised personnel at existing collection centres.



Information Servicing

(Required for the units adopt R32/R290 Refrigerant only)

13

1. Checks to the area

Prior to beginning work on systems containing flammable refrigerants, safety checks are necessary to ensure that the risk of ignition is minimised. For repair to the refrigerating system, the following precautions shall be complied with prior to conducting work on the system.

2. Work procedure

Works shall be undertaken under a controlled procedure so as to minimise the risk of a flammable gas or vapour being present while the work is being performed.

3. General work area

All maintenance staff and others working in the local area shall be instructed on the nature of work being carried out. Work in confined spaces shall be avoided. The area around the work space shall be sectioned off. Ensure that the conditions within the area have been made safe by control of flammable material.

4. Checking for presence of refrigerant

The area shall be checked with an appropriate refrigerant detector prior to and during work, to ensure the technician is aware of potentially flammable atmospheres. Ensure that the leak detection equipment being used is suitable for use with flammable refrigerants, i.e. no sparking, adequately sealed or intrinsically safe.

5. Presence of fire extinguisher

If any hot work is to be conducted on the refrigeration equipment or any associated parts, appropriate fire extinguishing equipment shall be available to hand. Have a dry power or CO₂ fire extinguisher adjacent to the charging area.

6. No ignition sources

No person carrying out work in relation to a refrigeration system which involves exposing any pipe work that contains or has contained flammable refrigerant shall use any sources of ignition in such a manner that it may lead to the risk of fire or explosion. All possible ignition sources, including cigarette smoking, should be kept sufficiently far away from the site of installation, repairing, removing and disposal, during which flammable refrigerant can possibly be released to the surrounding space. Prior to work taking place, the area around the equipment is to be surveyed to make sure that there are no flammable hazards or ignition risks. NO SMOKING signs shall be displayed.

7. Ventilated area

Ensure that the area is in the open or that it is adequately ventilated before breaking into the system or conducting any hot work. A degree of ventilation shall continue during the period that the work is carried out. The ventilation should safely disperse any released refrigerant and preferably expel it externally into the atmosphere.

8. Checks to the refrigeration equipment

Where electrical components are being changed, they shall be fit for the purpose and to the correct specification. At all times the manufacturer's maintenance and service guidelines shall be followed. If in doubt consult the manufacturer's technical department for assistance. The following checks shall be applied to installations using flammable refrigerants:

- the charge size is in accordance with the room size within which the refrigerant containing parts are installed;
- the ventilation machinery and outlets are operating adequately and are not obstructed;
- if an indirect refrigerating circuit is being used, the secondary circuits shall be checked for the presence of refrigerant; marking to the equipment continues to be visible and legible.
- marking and signs that are illegible shall be corrected;
- refrigeration pipe or components are installed in a position where they are unlikely to be exposed to any substance which may corrode refrigerant containing components, unless
- the components are constructed of materials which are inherently resistant to being
- corroded or are suitably protected against being so corroded.

9. Checks to electrical devices

Repair and maintenance to electrical components shall include initial safety checks and component inspection procedures. If a fault exists that could compromise safety, then no electrical supply shall be connected to the circuit until it is satisfactorily dealt with. If the fault cannot be corrected immediately but it is necessary to continue operation, and adequate temporary solution shall be used. This shall be reported to the owner of the equipment so all parties are advised.

Initial safety checks shall include:

- that capacitors are discharged: this shall be done in a safe manner to avoid possibility of sparking
- that there no live electrical components and wiring are exposed while charging, recovering or purging the system;
- that there is continuity of earth bonding.

10. Repairs to sealed components

10.1 During repairs to sealed components, all electrical supplies shall be disconnected from the equipment being worked upon prior to any removal of sealed covers, etc. If it is absolutely necessary to have an electrical supply to equipment during servicing, then a permanently operating form of leak detection shall be located at the most critical point to warn of a potentially hazardous situation.

10.2 Particular attention shall be paid to the following to ensure that by working on electrical components, the casing is not altered in such a way that the level of protection is affected. This shall include damage to cables, excessive number of connections, terminals not made to original specification, damage to seals, incorrect fitting of glands, etc.

- Ensure that apparatus is mounted securely.
- Ensure that seals or sealing materials have not degraded such that they no longer serve the purpose of preventing the ingress of flammable atmospheres. Replacement parts shall be in accordance with the manufacturer s specifications.

NOTE: The use of silicon sealant may inhibit the effectiveness of some types of leak detection equipment. Intrinsically safe components do not have to be isolated prior to working on them.

11. Repair to intrinsically safe components

Do not apply any permanent inductive or capacitance loads to the circuit without ensuring that this will not exceed the permissible voltage and current permitted for the equipment in use. Intrinsically safe components are the only types that can be worked on while live in the presence of a flammable atmosphere. The test apparatus shall be at the correct rating.

Replace components only with parts specified by the manufacturer. Other parts may result in the ignition of refrigerant in the atmosphere from a leak.

12. Cabling

Check that cabling will not be subject to wear, corrosion, excessive pressure, vibration, sharp edges or any other adverse environmental effects. The check shall also take into account the effects of aging or continual vibration from sources such as compressors or fans.

13. Detection of flammable refrigerants

Under no circumstances shall potential sources of ignition be used in the searching for or detection of refrigerant leaks. A halide torch (or any other detector using a naked flame) shall not be used.

14. Leak detection methods

The following leak detection methods are deemed acceptable for systems containing flammable refrigerants. Electronic leak detectors shall be used to detect flammable refrigerants, but the sensitivity may not be adequate, or may need re-calibration. (Detection equipment shall be calibrated in a refrigerant-free area.) Ensure that the detector is not a potential source of ignition and is suitable for the refrigerant. Leak detection equipment shall be set at a percentage of the LFL of the refrigerant and shall be calibrated to the refrigerant employed and the appropriate percentage of gas (25% maximum) is confirmed. Leak detection fluids are suitable for use with most refrigerants but the use of detergents containing chlorine shall be avoided as the chlorine may react with the refrigerant and corrode the copper pipe-work.

If a leak is suspected, all naked flames shall be removed or extinguished. If a leakage of refrigerant is found which requires brazing, all of the refrigerant shall be recovered from the system, or isolated (by means of shut off valves) in a part of the system remote from the leak. Oxygen free nitrogen (OFN) shall then be purged through the system both before and during the brazing process.

15. Removal and evacuation

When breaking into the refrigerant circuit to make repairs or for any other purpose conventional procedures shall be used. However, it is important that best practice is followed since flammability is a consideration. The following procedure shall be adhered to:

- remove refrigerant;
- purge the circuit with inert gas;
- evacuate;
- purge again with inert gas;
- open the circuit by cutting or brazing.

The refrigerant charge shall be recovered into the correct recovery cylinders. The system shall be flushed with OFN to render the unit safe. This process may need to be repeated several times. Compressed air or oxygen shall not be used for this task.

Flushing shall be achieved by breaking the vacuum in the system with OFN and continuing to fill until the working pressure is achieved, then venting to atmosphere, and finally pulling down to a vacuum. This process shall be repeated until no refrigerant is within the system.

When the final OFN charge is used, the system shall be vented down to atmospheric pressure to enable work to take place. This operation is absolutely vital if brazing operations on the pipe-work are to take place.

Ensure that the outlet for the vacuum pump is not closed to any ignition sources and there is ventilation available.

16. Charging procedures

In addition to conventional charging procedures, the following requirements shall be followed:

- Ensure that contamination of different refrigerants does not occur when using charging equipment. Hoses or lines shall be as short as possible to minimize the amount of refrigerant contained in them.
- Cylinders shall be kept upright.
- Ensure that the refrigeration system is earthed prior to charging the system with refrigerant.
- Label the system when charging is complete(if not already).
- Extreme care shall be taken not to overfill the refrigeration system.
- Prior to recharging the system it shall be pressure tested with OFN. The system shall be leak tested on completion of charging but prior to commissioning. A follow up leak test shall be carried out prior to leaving the site.

17. Decommissioning

Before carrying out this procedure, it is essential that the technician is completely familiar with the equipment and all its detail. It is recommended good practice that all refrigerants are recovered safely. Prior to the task being carried out, an oil and refrigerant sample shall be taken.

In case analysis is required prior to re-use of reclaimed refrigerant. It is essential that electrical power is available before the task is commenced.

- a) Become familiar with the equipment and its operation.
- b) Isolate system electrically
- c) Before attempting the procedure ensure that:
 - mechanical handling equipment is available, if required, for handling refrigerant cylinders;
 - all personal protective equipment is available and being used correctly;
 - the recovery process is supervised at all times by a competent person;
 - recovery equipment and cylinders conform to the appropriate standards.
- d) Pump down refrigerant system, if possible.
- e) If a vacuum is not possible, make a manifold so that refrigerant can be removed from various parts of the system.
- f) Make sure that cylinder is situated on the scales before recovery takes place.
- g) Start the recovery machine and operate in accordance with manufacturer's instructions.
- h) Do not overfill cylinders. (No more than 80% volume liquid charge).
- i) Do not exceed the maximum working pressure of the cylinder, even temporarily.
- j) When the cylinders have been filled correctly and the process completed, make sure that the cylinders and the equipment are removed from site promptly and all isolation valves on the equipment are closed off.
- k) Recovered refrigerant shall not be charged into another refrigeration system unless it has been cleaned and checked.

18. Labelling

Equipment shall be labelled stating that it has been de-commissioned and emptied of refrigerant. The label shall be dated and signed. Ensure that there are labels on the equipment stating the equipment contains flammable refrigerant.

19. Recovery

- When removing refrigerant from a system, either for service or decommissioning, it is recommended good practice that all refrigerants are removed safely.
- When transferring refrigerant into cylinders, ensure that only appropriate refrigerant recovery cylinders are employed. Ensure that the correct numbers of cylinders for holding the total system charge are available. All cylinders to be used are designated for the recovered refrigerant and labelled for that refrigerant (i.e special cylinders for the recovery of refrigerant). Cylinders shall be complete with pressure relief valve and associated shut-off valves in good working order.
- Empty recovery cylinders are evacuated and, if possible, cooled before recovery occurs.
- The recovery equipment shall be in good working order with a set of instructions concerning the equipment that is at hand and shall be suitable for the recovery of flammable refrigerants. In addition, a set of calibrated weighing scales shall be available and in good working order.
- Hoses shall be complete with leak-free disconnect couplings and in good condition. Before using the recovery machine, check that it is in satisfactory working order, has been properly maintained and that any associated electrical components are sealed to prevent ignition in the event of a refrigerant release. Consult manufacturer if in doubt.
- The recovered refrigerant shall be returned to the refrigerant supplier in the correct recovery cylinder, and the relevant Waste Transfer Note arranged. Do not mix refrigerants in recovery units and especially not in cylinders.
- If compressors or compressor oils are to be removed, ensure that they have been evacuated to an acceptable level to make certain that flammable refrigerant does not remain within the lubricant. The evacuation process shall be carried out prior to retraining the compressor to the suppliers. Only electric heating to the compressor body shall be employed to accelerate this process. When oil is drained from a system, it shall be carried out safely.

20. Transportation, marking and storage for units

1. Transport of equipment containing flammable refrigerants
Compliance with the transport regulations
2. Marking of equipment using signs
Compliance with local regulations
3. Disposal of equipment using flammable refrigerants
Compliance with national regulations
4. Storage of equipment/appliances
The storage of equipment should be in accordance with the manufacturer's instructions.
5. Storage of packed (unsold) equipment
Storage package protection should be constructed such that mechanical damage to the equipment inside the package will not cause a leak of the refrigerant charge.
The maximum number of pieces of equipment permitted to be stored together will be determined by local regulations.

The design and specifications are subject to change without prior notice for product improvement. Consult with the sales agency or manufacturer for details.

Technical features (Light Commercial)

Outdoor unit	MC2-Y	35M	53M	70M	105M	105T	140T	160T
Refrigerant lines								
Liquid line	∅	1/4"	1/4"	3/8"	3/8"	3/8"	3/8"	3/8"
	mm	6,35	6,35	9,52	9,52	9,52	9,52	9,52
Gas line	∅	3/8"	1/2"	5/8"	5/8"	5/8"	5/8"	5/8"
	mm	9,52	12,7	15,9	15,9	15,9	15,9	15,9
Max. equivalent length	m	25	25	30	30	35	35	35
Max. length ODU / IDU	m	±10	±20	±25	±30	±30	±30	±30
Refrigerant pre-charge	kg/m	0,87 / 5	1,35 / 5	1,5 / 5	2,4 / 5	2,4 / 5	2,8 / 5	2,95 / 5
GWP	tco ₂	675	675	675	675	675	675	675
Tons of CO ₂ equivalent	t ₁	0,59	0,91	1,01	1,62	1,62	1,89	1,99
Additional refrigerant charge	g/m	12	12	24	24	24	24	24

Outdoor unit		35M	53M	70M	105M	105T	140T	160T
Electrical connections								
Power supply	ODU --> IDU / Unit singles		ODU --> IDU	ODU --> IDU	Unit singles	Unit singles	Unit singles	Unit singles
	ODU - Voltage/ Frequency/Phases	V/Hz/n°	230 / 50 / 1	230 / 50 / 1	230 / 50 / 1	230 / 50 / 1	400 / 50 / 3 + N	400 / 50 / 3 + N
	ODU - n° cable/ section		2 x 2,5mm ² + T	2 x 2,5mm ² + T	2 x 2,5mm ² + T	2 x 4mm ² + T	4 x 2,5mm ² + T	4 x 2,5mm ² + T
	IDU - Voltage/ Frequency/Phases	V/Hz/n°	-	-	230 / 50 / 1	230 / 50 / 1	230 / 50 / 1	230 / 50 / 1
	IDU - n° cable/ section		-	-	2 x 1mm ² + T	2 x 1mm ² + T	2 x 1mm ² + T	2 x 1mm ² + T
Communication type	n° cable/ section		4 x 1mm ² + T	3 x 1mm ² + T	2 x 0,2mm ² + T	2 x 0,2mm ² + T	2 x 0,2mm ² + T	2 x 0,2mm ² + T

NOTE

- at the max length of the pipes, the yield is about 90%
- with a height difference > 5m it is recommend to insert a siphon.

ODU: outdoor unit

IDU: indoor unit



OWNER'S MANUAL

Box - SL 950x950

SUPER-SLIM FOUR-WAY CASSETTE



IMPORTANT NOTE:

Read this manual carefully before installing for or operating your new air conditioning unit.

Make sure to save this manual future reference.



Change living home

Table of Contents

Owner's Manual

1 Safety Precautions 04



2 Indoor Unit Parts and Major Functions 05

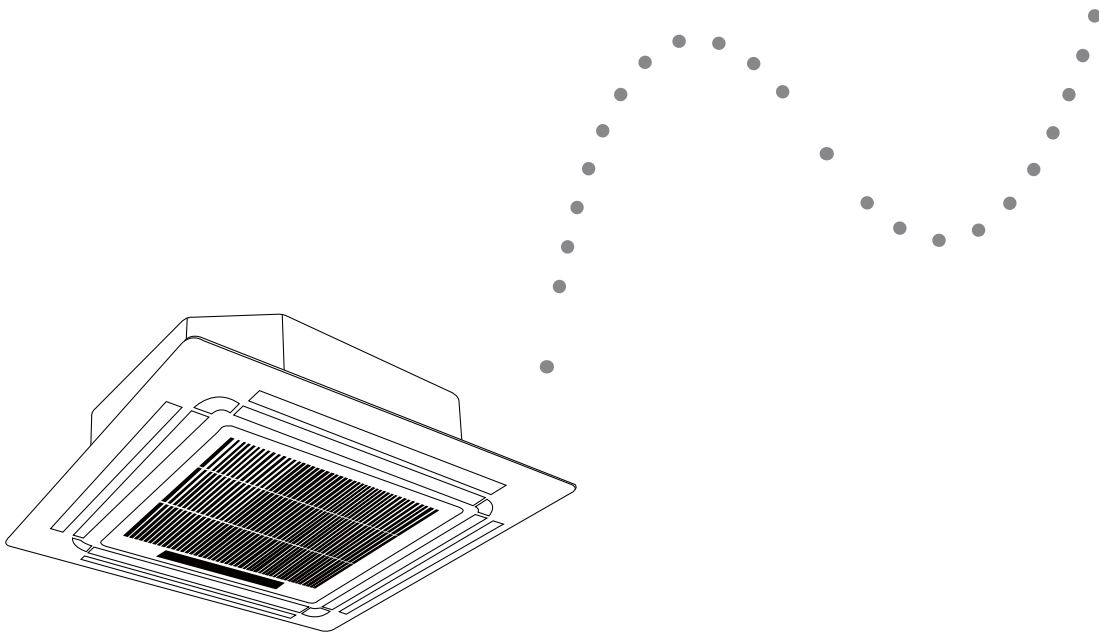

3 Manual Operation 07

(

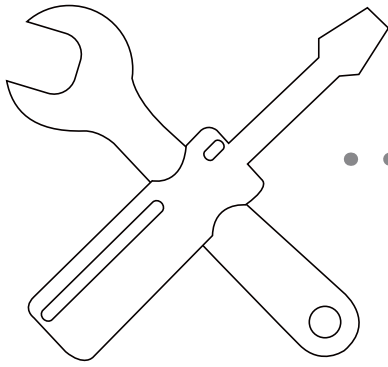

4	Care and Maintenance	08
	a. Unit Maintenance	08
	b. How to Clean the Air Filter	08
	c. Repairing Refrigerant Leaks	08
	d. Preparation for Periods of Non-use	09

5	Troubleshooting	10
	a. Common Problems	10
	b. Troubleshooting Tips	11

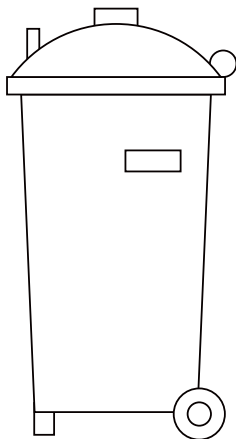
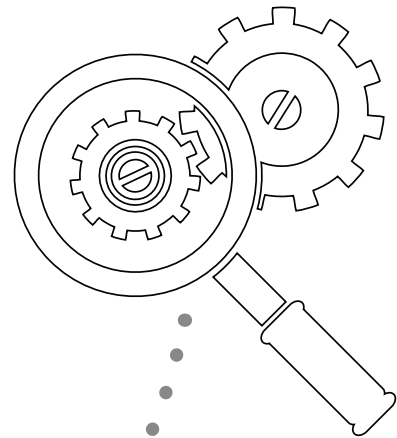

6	European Disposal Guidelines	13
----------	------------------------------------	----

Safety Precautions

1

Thank you for purchasing this air conditioner. This manual will provide you with information on how to operate, maintain, and troubleshoot your air conditioner. Following the instructions will ensure the proper function and extended lifespan of your unit.

Please pay attention to the following signs:



WARNING

Failure to observe a warning may result in death. The appliance must be installed in accordance with national regulations.



CAUTION

Failure to observe a caution may result in injury or equipment damage.

WARNING

- Ask an authorized dealer to install this air conditioner. Inappropriate installation may cause water leakage, electric shock, or fire.
- The warranty will be voided if the unit is not installed by professionals.
- If abnormal situation arises (like burning smell), turn off the power supply and call your dealer for instructions to avoid electric shock, fire or injury.
- DO NOT let the indoor unit or the remote control get wet. It may cause electric shock or fire.
- DO NOT insert fingers, rods or other objects into the air inlet or outlet. This may cause injury, since the fan may be rotating at high speeds.
- DO NOT use a flammable spray such as hair spray, lacquer or paint near the unit. This may cause fire or combustion.

CAUTION

- DO NOT touch the air outlet while the swing flap is in motion. Fingers might get caught or the unit may break down.
- DO NOT inspect the unit by yourself. Ask an authorized dealer to perform the inspection.
- To prevent product deterioration, do not use the air conditioner for preservation purposes (storage of food, plants, animals, works of art, etc.).
- DO NOT touch the evaporator coils inside the indoor unit. The evaporator coils are sharp and may cause injury.

- DO NOT operate the air conditioner with wet hands. It may cause electric shock.
- DO NOT place items that might be affected by moisture damage under the indoor unit. Condensation can occur at a relative humidity of 80%.
- DO NOT expose heat-producing appliances to cold air or place them under the indoor unit. This may cause incomplete combustion or deformation of the unit due to the heat.
- After long periods of usage, check the indoor unit to see if anything is damaged. If the indoor unit is damaged, it may fall and cause injury.
- If the air conditioner is used together with other heating devices, thoroughly ventilate the room to avoid oxygen deficiency.
- DO NOT climb onto or place objects on top of the outdoor unit.
- DO NOT operate the air conditioner when using fumigant insecticides. The chemicals may become layered with the unit and endanger those who are hypersensitive to chemicals.
- DO NOT let children play with the air conditioner.
- The air conditioner can be used by children aged 8 years and older and people with reduced physical, sensory or mental capabilities, or lack of experience and knowledge, if they have been given instruction on how to properly and safely operate the system.
- DO NOT operate the air conditioner in a wet room (e.g. bathroom or laundry room). This can cause electrical shock and cause the product to deteriorate.

Indoor Unit Parts And Major Functions

Unit Parts

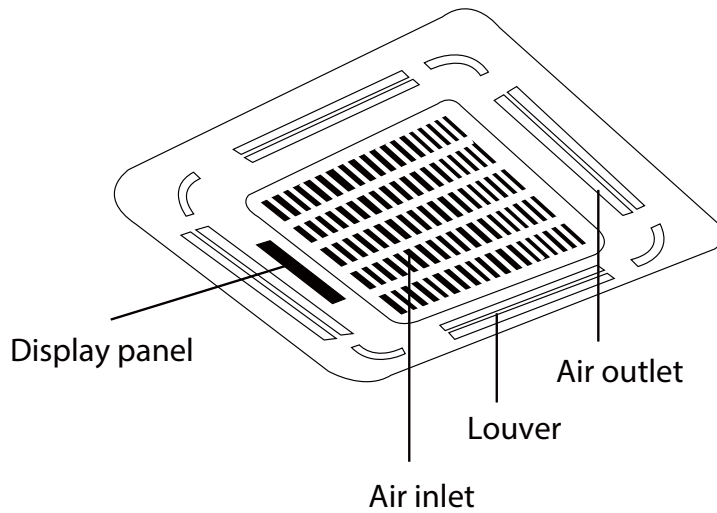

Fig. 2.1

Operating Conditions

Use the system in the following temperature for safe and effective operation. If the air conditioner is used outside of the following conditions, it may malfunction or be less efficient.

	COOL Mode	HEAT mode	DRY mode
Indoor Temperature	17-32°C (62-90°F)	0-30°C (32-86°F)	17-32°C (62-90°F)
Outdoor Temperature	0-50°C (32-122°F)	-15-24°C (5-76°F)	0-50°C (32-122°F)
	-15-50°C (5-122°F) (low temperature cooling models)		

Features

Default Setting

When the air conditioner restarts after a power failure, it will default to the factory settings (AUTO mode, AUTO fan, 24°C (76°F)). This may cause inconsistencies on the remote control and unit panel. Use your remote control to update the status.

Auto-Restart (some models)

In case of power failure, the system will immediately stop. When power returns, the Operation light on the indoor unit will flash. To restart the unit, press the ON/OFF button on the remote control. If the system has an auto restart function, the unit will restart using the same settings.

Louver Angle Memory Function (Optional)

Some models are designed with a louver angle memory function. When the unit restarts after a power failure, the angle of the horizontal louvers will automatically return to the previous position. The angle of the horizontal louver should not be set too small as condensation may form and drip into the machine. To reset the louver, press the manual button, which will reset the horizontal louver settings.

Refrigerant Leak Detection System (some models)

In the event of a refrigerant leak, the LCD screen will display "EC" and the LED indicator light will flash.

Energy Saving Tips

- **DO NOT** set the unit to excessive temperature levels.
- While cooling, close the curtains to avoid direct sunlight.
- Doors and windows should be kept closed to keep cool or warm air in the room.
- **DO NOT** place objects near the air inlet and outlet of the unit. This will reduce the efficiency of the unit.
- Set a timer and use the built-in SLEEP/ECONOMY mode if applicable.
- If you don't plan to use the unit for a long time, remove the batteries from the remote control.
- Clean the air filter every two weeks. A dirty filter can reduce cooling or heating efficiency.
- Adjust louvers properly and avoid direct airflow.

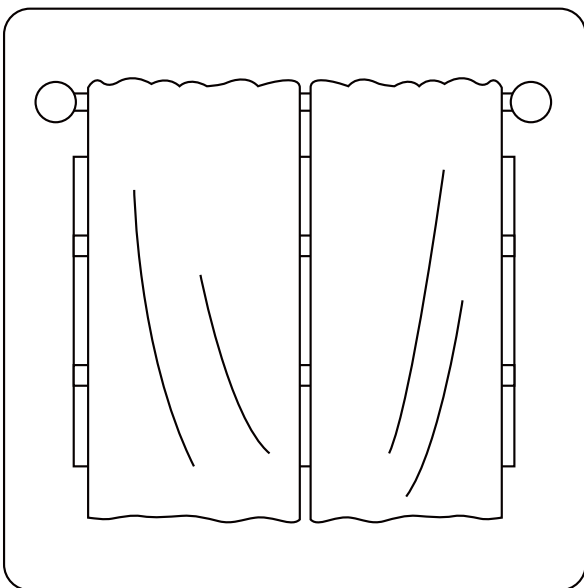

Closing the curtains while heating also helps keep the heat in

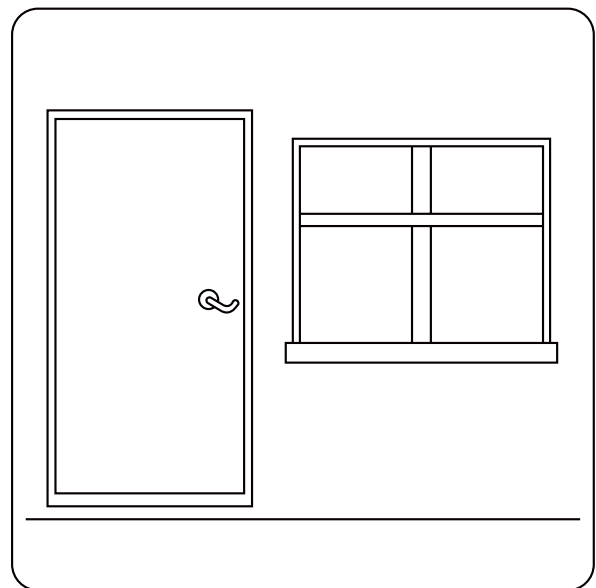

Doors and windows should be kept closed

This display panel on the indoor unit can be used to operate the unit in case the remote control has been misplaced or is out of batteries.

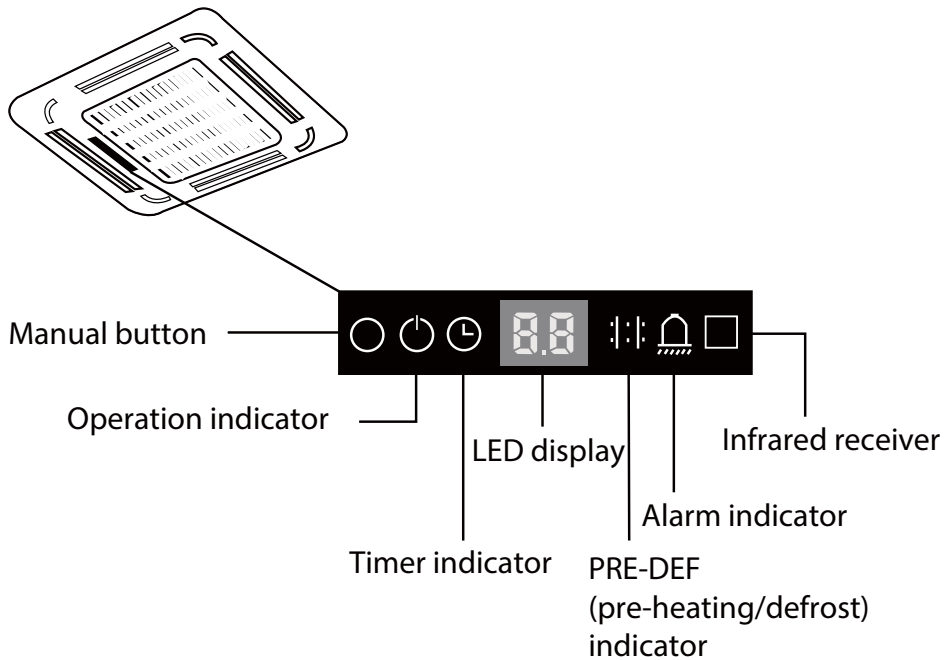

Fig. 3.1

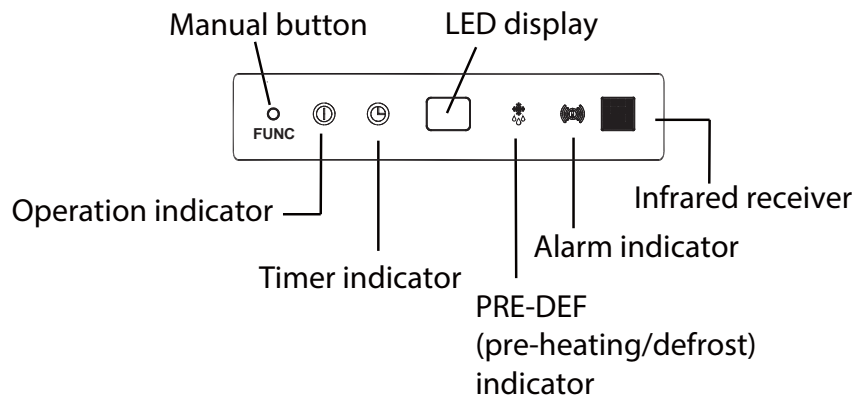

Fig. 3.2

- **MANUAL button:** This button selects the mode in the following order: AUTO, FORCED COOL, OFF.
- **FORCED COOL mode:** In FORCED COOL mode, the Operation light flashes. The system will then turn to AUTO after it has cooled with a high wind speed for 30 minutes. The remote control will be disabled during this operation.
- **OFF mode:** When the panel is turned OFF, the unit turns off and the remote control is re-enabled.

Safety Precautions

- Contact an authorized service technician for repair or maintenance of this unit. Improper repair and maintenance may cause water leakage, electrical shock, or fire, and may void your warranty.
- **DO NOT** substitute a blown fuse with a higher or lower amperage rating fuse, as this may cause circuit damage or an electrical fire.
- Please make sure the drain hose is set up according to the instructions. Failure to do so could cause leakage and result in personal property damage, fire and electric shock.
- Make sure that all wires are connected properly. Failure to connect wires according to instructions can result in electrical shock or fire.

Unit Maintenance

BEFORE CLEANING OR MAINTENANCE

- Always turn off your air conditioning system and disconnect its power supply before cleaning or maintenance.
- **DO NOT** use chemicals or chemically treated cloths to clean the unit
- **DO NOT** use benzene, paint thinner, polishing powder or other solvents to clean the unit. They can cause the plastic surface to crack or deform.
- **DO NOT** wash the unit under running water. Doing so causes electrical danger.
- **DO NOT** use water hotter than 40°C (104°F) to clean the front panel. This can cause the panel to deform or become discolored.
- Clean the unit using a damp, lint-free cloth and neutral detergent. Dry the unit with a dry, lint-free cloth.

How To Clean The Air Filter

The filter prevents dust and other particles from entering the indoor unit. Dust buildup can reduce the efficiency of the air conditioner. For optimum efficiency, clean the air filter every two weeks or more frequently if you live in a dusty area. Replace the filter with a new one if it's heavily clogged and unable to be cleaned.

WARNING: DO NOT REMOVE OR CLEAN THE FILTER BY YOURSELF

Removing and cleaning the filter can be dangerous. Removal and maintenance must be performed by a certified technician.

NOTE: In households with animals, you will have to periodically wipe down the grille to prevent blocked airflow due to animal hair.

1. Unlock the grille by pushing the two tabs towards the middle simultaneously.
2. Unplug the display panel cable from the control box on the main body.

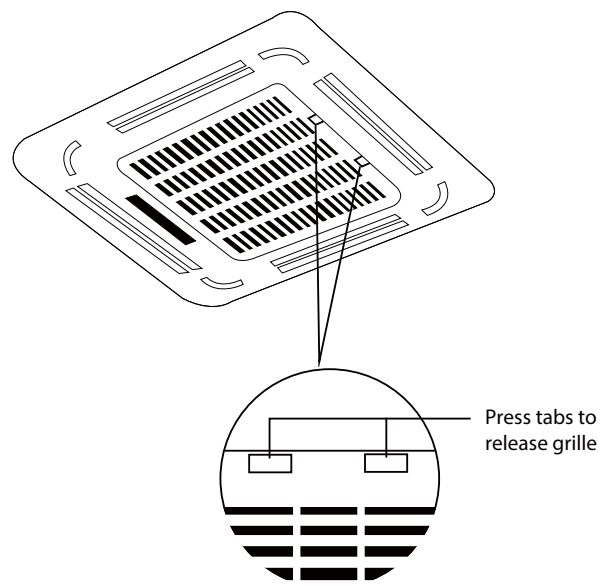

Fig. 4.1

3. Detach the grille from the main unit by holding the grille at a 45° angle, lifting it up slightly and then pulling the grille forward.

NOTE: Some models include an auto-lifting panel function, which allows the grill to move vertically and simplifies the filter cleaning process.

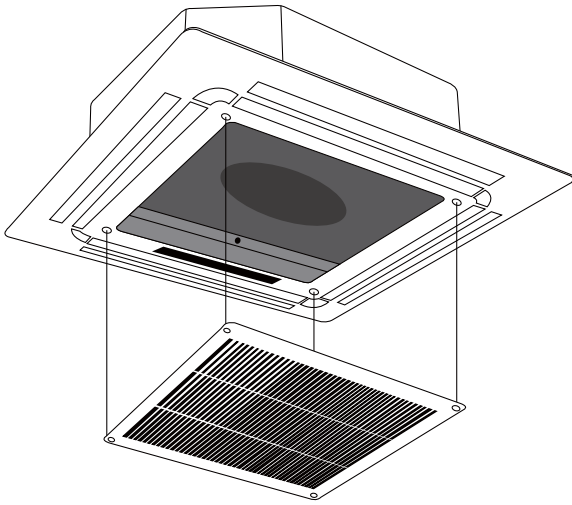

Fig. 4.2

4. Remove the air filter.
5. Clean the air filter by vacuuming the surface or washing it in warm water with mild detergent.
 - A. If using a vacuum cleaner, the inlet side should face the vacuum.

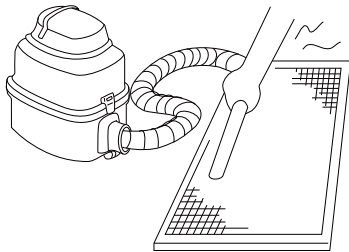

Fig. 4.3

- B. If using water, the inlet side should face down and away from the water stream.

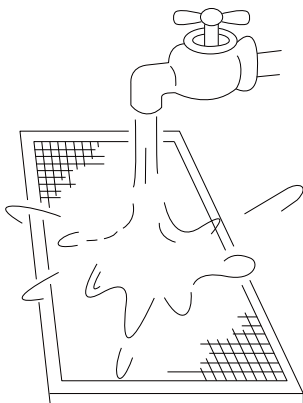

Fig. 4.4

6. Rinse the filter with clean water and allow it to air-dry. **DO NOT** let the filter dry in direct sunlight.
7. Reinstall the filter.
8. Reinstall the front grille and reconnect the display panel cable to the control box on the main body.

Repairing Refrigerant Leaks

! WARNING

- If the refrigerant leaks, turn off the air conditioner and any combustible heating devices, ventilate the room and call your dealer immediately. Refrigerant is both toxic and flammable. **DO NOT** use the air conditioner until the leak is repaired.
- When the air conditioner is installed in a small room, measures must be taken to prevent the refrigerant concentration from exceeding the safety limit in the event of refrigerant leakage. Concentrated refrigerant causes a severe health and safety threat.

Refrigerant Leak Detection System (some models)

- In the event of a refrigerant leak, the LCD screen will display "EC" and the LED indicator light will flash.

Preparation For Periods Of Non-Use

Maintenance after Extended Non-Use

1. Remove any obstacles blocking the vents of both the indoor and outdoor units.
2. Clean the air filter and the front grille of the indoor unit. Reinstall the clean, dry air filter in its original position.
3. Turn on the main power switch at least 12 hours prior to operating the unit.

Storing the Unit While Not In Use

1. Run the appliance on FAN mode for 12 hours in a warm room to dry it and prevent mold.
2. Turn off the appliance and unplug it.
3. Clean the air filter according to the instructions in the previous section. Reinstall the clean, dry filter before storing.
4. Remove the batteries from the remote control.

! CAUTIONS

If one of the following conditions occurs, switch off the power supply immediately and contact your dealer for further assistance.

- The operation light continues to flash rapidly after the unit has been restarted.
- The remote control buttons do not work.
- The unit continually trips fuses or circuit breakers.
- A foreign object or water enters the air conditioner.
- The indoor unit leaks.

Common Problems

The following symptoms are not a malfunction and in most situations will not require repairs.

Problem	Possible Causes
Unit does not turn on when pressing ON/OFF button	The unit has a 3-minute protection feature that prevents the unit from overloading. The unit cannot be restarted within three minutes of being turned off.
	Cooling and Heating Models: If the Operation light and PRE-DEF (Pre-heating/Defrost) indicators are lit up, the outdoor temperature is too cold and the unit's anti-cold wind is activated in order to defrost the unit.
	In Cooling-only Models: If the "Fan Only" indicator is lit up, the outdoor temperature is too cold and the unit's anti-freeze protection is activated in order to defrost the unit.
The unit changes from COOL mode to FAN mode	The unit changes its setting to prevent frost from forming on the unit. Once the temperature increases, the unit will start operating again.
	The set temperature has been reached, at which point the unit turns off the compressor. The unit will resume operating when the temperature fluctuates again.
The indoor unit emits white mist	In humid regions, a large temperature difference between the room's air and the conditioned air can cause white mist.
Both the indoor and outdoor units emit white mist	When the unit restarts in HEAT mode after defrosting, white mist may be emitted due to moisture generated from the defrosting process.
The indoor unit makes noises	A squeaking sound is heard when the system is OFF or in COOL mode. The noise is also heard when the drain pump (optional) is in operation.
	A squeaking sound may occur after running the unit in HEAT mode due to expansion and contraction of the unit's plastic parts.
Both the indoor unit and outdoor unit make noises	A low hissing sound may occur during operation. This is normal and is caused by refrigerant gas flowing through both the indoor and outdoor units.
	A low hissing sound may be heard when the system starts, has just stopped running or is defrosting. This noise is normal and is caused by the refrigerant gas stopping or changing direction.
The outdoor unit makes noises	The unit will make different sounds based on its current operating mode.

Problem	Possible Causes
Dust is emitted from either the indoor or outdoor unit	The unit may accumulate dust during extended periods of non-use, which will be emitted when the unit is turned on. This can be mitigated by covering the unit during long periods of inactivity.
The unit emits a bad odor	The unit may absorb odors from the environment (such as furniture, cooking, cigarettes, etc.) which will be emitted during operations.
	The unit's filters have become moldy and should be cleaned.
The fan of the outdoor unit does not operate	During operation, the fan speed is controlled to optimize product operation.

Troubleshooting Tips

When troubles occur, please check the following points before contacting a repair company.

Problem	Possible Causes	Solution
The unit is not working	Power failure	Wait for the power to be restored
	The power switch is off	Turn on the power
	The fuse is burned out	Replace the fuse
	Remote control batteries are dead	Replace the remote control batteries
	The unit's 3-minute protection has been activated	Wait three minutes after restarting the unit
Poor cooling performance	Temperature setting may be higher than the ambient room temperature	Lower the temperature setting
	The heat exchanger on the indoor or outdoor unit is dirty	Clean the affected heat exchanger
	The air filter is dirty	Remove the filter and clean it according to instructions
	The air inlet or outlet of either unit is blocked	Turn the unit off, remove the obstruction and turn it back on
	Doors and windows are open	Make sure that all doors and windows are closed while operating the unit
	Excessive heat is generated by sunlight	Close windows and curtains during periods of high heat or bright sunshine
	Low refrigerant due to leak or long-term use	Check for leaks, re-seal if necessary and top off refrigerant
The unit starts and stops frequently	There's too much or too little refrigerant in the system	Check for leaks and recharge the system with refrigerant
	There is air, incompressible gas or foreign material in the refrigeration system.	Evacuate and recharge the system with refrigerant
	System circuit is blocked	Determine which circuit is blocked and replace the malfunctioning piece of equipment
	The compressor is broken	Replace the compressor
	The voltage is too high or too low	Install a manostat to regulate the voltage
Poor heating performance	The outdoor temperature is lower than 7°C (44.5°F)	Check for leaks and recharge the system with refrigerant
	Cold air is entering through doors and windows	Make sure that all doors and windows are closed during use
	Low refrigerant due to leak or long-term use	Check for leaks, re-seal if necessary and top off refrigerant

Error Code	Cause	The number of flashes per second	Timer indicator
E0	Indoor EEPROM (Electrically Erasable Programmable Read-Only Memory) error	1	Off
E 1	Indoor and outdoor unit communication malfunction	2	Off
E3	Indoor fan speed malfunction	4	Off
E4	Indoor room temperature sensor error	5	Off
E5	Evaporator coil temperature sensor error	6	Off
EC	Refrigerant leak detection system malfunction	7	Off
EE	Water level alarm malfunction	8	Off
E8	Dual indoor unit (twin model only) communication malfunction	9	Off
E9	Other twin model malfunction	10	Off
F0	Overload protection	1	On
F 1	Outdoor temperature sensor error	2	On
F2	Outdoor condenser pipe sensor error	3	On
F3	Discharge air temperature sensor error	4	On
F4	Outdoor EEPROM (Electrically Erasable Programmable Read-Only Memory) error	5	On
F5	Outdoor fan speed (DC fan motor only) malfunction	6	On
P0	Inverter module IPM protection	1	Flash
P 1	High/Low voltage protection	2	Flash
P2	Compressor top overheating protection	3	Flash
P3	Outdoor low temperature protection	4	Flash
P4	Compressor drive error	5	Flash
P5	Mode conflict	6	Flash
P6	Compressor low-pressure protection	7	Flash
P7	Outdoor IGBT sensor error	8	Flash
FA	Indoor unit communication malfunction	11	On

The manufacturer is registered on the EEE National Register, in compliance with implementation of Directive 2012/19/EU and relevant national regulations on waste electrical and electronic equipment. This Directive requires electrical and electronic equipment to be disposed of properly. Equipment bearing the crossed-out wheelee bin mark must be disposed of separately at the end of its life cycle to prevent damage to human health and to the environment.

Electrical and electronic equipment must be disposed of together with all of its parts.

To dispose of "household" electrical and electronic equipment, the manufacturer recommends you contact an authorised dealer or an authorised ecological area.

"Professional" electrical and electronic equipment must be disposed of by authorised personnel through established waste disposal authorities around the country.

In this regard, here is the definition of household WEEE and professional WEEE:

WEEE from private households: WEEE originating from private households and WEEE which comes from commercial, industrial, institutional and other sources which, because of its nature and quantity, is similar to that from private households. Subject to the nature and quantity, where the waste from EEE was likely to have been by both a private household and users of other than private households, it will be classed as private household WEEE;

Professional WEEE: all WEEE which comes from users other than private households.

This equipment may contain:

refrigerant gas, the entire contents of which must be recovered in suitable containers by specialised personnel with the necessary qualifications;

- lubrication oil contained in compressors and in the cooling circuit to be collected;
- mixtures with antifreeze in the water circuit, the contents of which are to be collected;
- mechanical and electrical parts to be separated and disposed of as authorised.

When machine components to be replaced for maintenance purposes are removed or when the entire unit reaches the end of its life and needs to be removed from the installation, waste should be separated by its nature and disposed of by authorised personnel at existing collection centres.

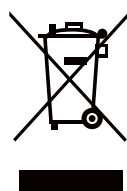

The design and specifications are subject to change without prior notice for product improvement. Consult with the sales agency or manufacturer for details.

Connections for LIGHT Commercial

FUNCTION OF SWITCH

SWITCH	FOR COM UNIT ADDRESS
S2	0~2
S1 + S2	3~12
ADDRESS	0~15
ADDRESS	16~31
ADDRESS	32~47
ADDRESS	48~63

ENCI SWITCH (FOR POWER)	NUMBER	POWER
4	4000W-5300W (2.0HP)	
5	5400W-7100W	
6	/	
7	7500W-9000W (3.2HP)	
8	9100W-10500W (4.0HP)	
9	12000W-14000W (5.0HP)	
A	14500W-16000W (6.0HP)	

SW3 SWITCH	FOR Auto-restart setting
ON STATE	ON
MODE	REMEMBER
Factory Setting	No-remember

SW6 SWITCH	FOR TEMP-COMPENSATION
ON STATE	ON
VALUE	6 4 2
Factory Setting	✓

Anti-cold air	SW1	FAN MOTOR STOP-TEM
ON STATE	ON	24
Factory Setting	✓	
ON STATE	ON	15
Factory Setting	✓	
ON STATE	ON	8
Factory Setting	✓	
ON STATE	ON	According to the EEPROM setting

SW2 SWITCH	FOR FAN MOTOR CONTROL when no power request.
ON STATE	ON
MODE	Fan OFF
Factory Setting	✓
ON STATE	ON
MODE	MAIN
Factory Setting	✓

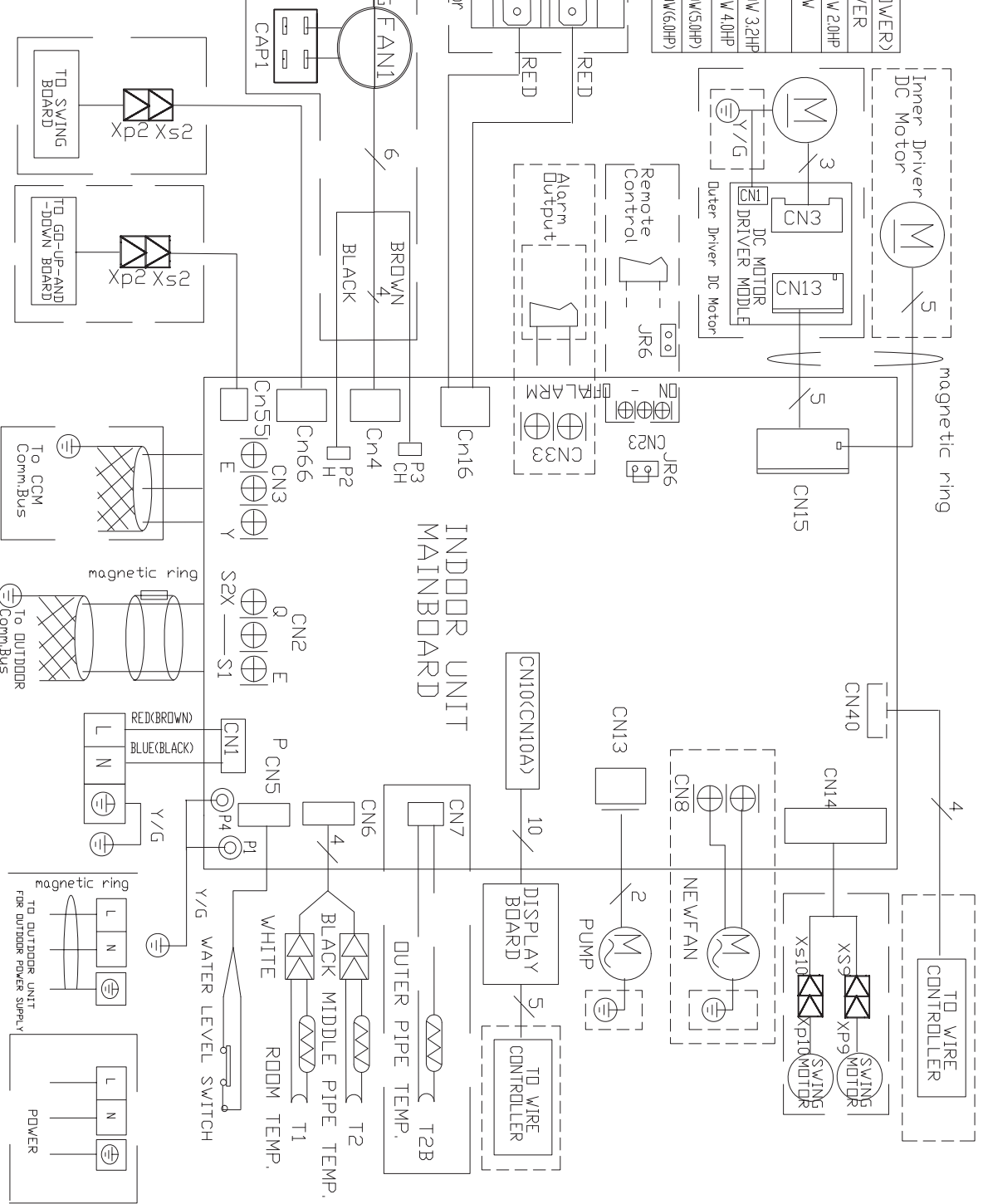

CLIVET Group Company of **Midea**

Client: Via Camp Long, 25 Villapalera 32022 Feltrè (BL) Italy
 Web: www.clivet.com Email: info@clivet.it Tel.: +39 0439 3131 -
 Fax: +39 0439 313300

Schema/Wiring Diagram: **A2-XY**

Series/Size: **70M-105M-140M-160M**

Model: **WD-EU-KFR530/BP3N1Y-A3(RD)J.D.Q.N.K.M.P-1**

Terminal/Supply: **230/1/50**

Light Commercial system
Indoor unit / Unità interna / Innergerät:

Cassette IA2-XY 70M-105M

CONNECTION METHOD 1: Indoor and Outdoor units with independent power supply
METODO di COLLEGAMENTO 1: Unità interna ed esterna con alimentazioni indipendenti
VERBINDUNGSMETHODE 1: Innengerät und Außengerät mit unabhängiger Stromversorgung

CODE:16022700000732

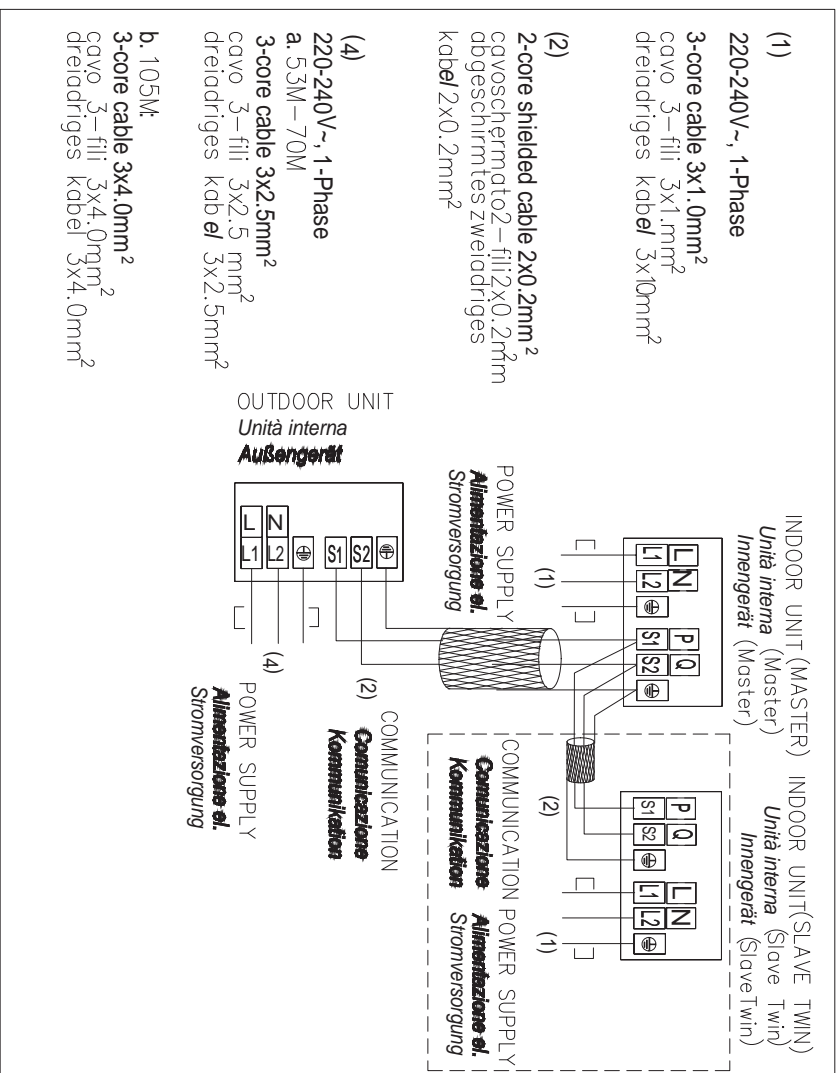
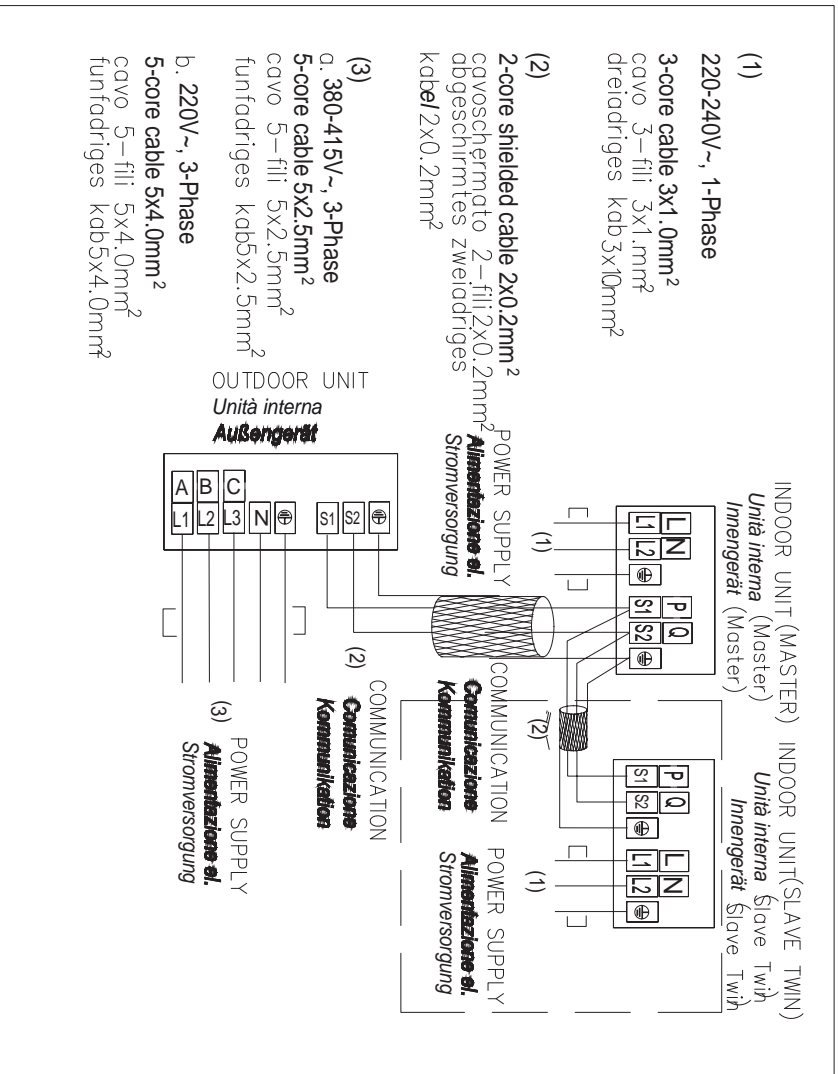

Clivet: Via Camp Lonc, 25 Villapalena 32027 Feltré (BL) Italy
 Web: www.clivet.com Email:info@clivet.it Tel.: +39 0439 3131 -
 Fax.: +39 0439 31310

Schema/Wiring Diagram: IA2-XY
 Serie/Series: IA2-XY
 Grandezza/Size: 70M-105M-140M-160M
 Tensione/Supply: 230/1/50

KFR160DLBP3-NWU-WX(T)2, J.D.D.L.NK.M.P.1

Cassette IA2-XY 70M-105M

CONNECTION METHOD 2: Indoor unit powered by Outdoor unit

METODO di COLLEGAMENTO 2: Unità interna alimentata da unità esterna
COVERBINDUNGSMETHODE 2: Innengerät, die von der Außengerät angetrieben wird

CODE:16022700000732

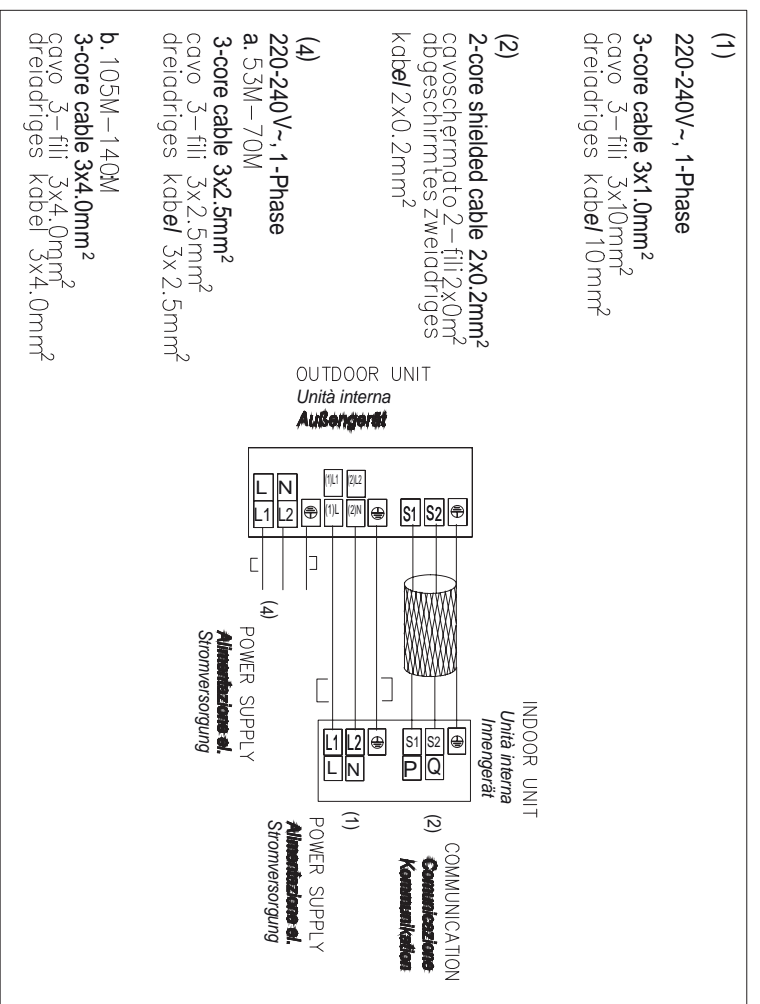
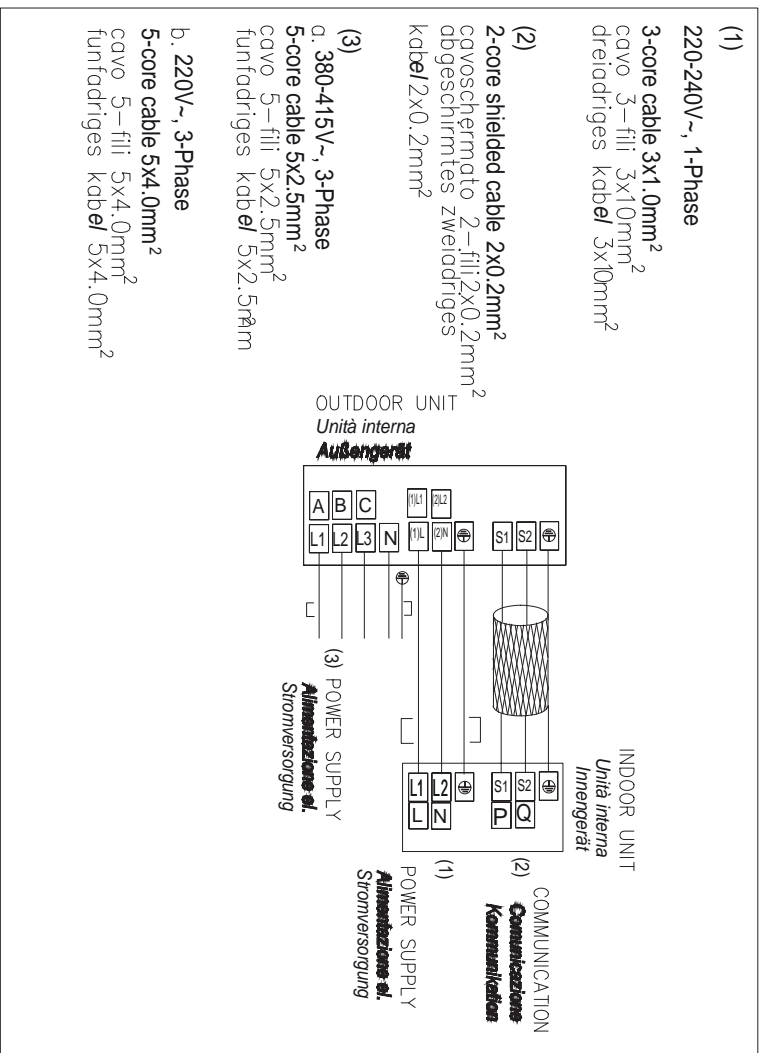

Cassette IA2 XY 140M-160M

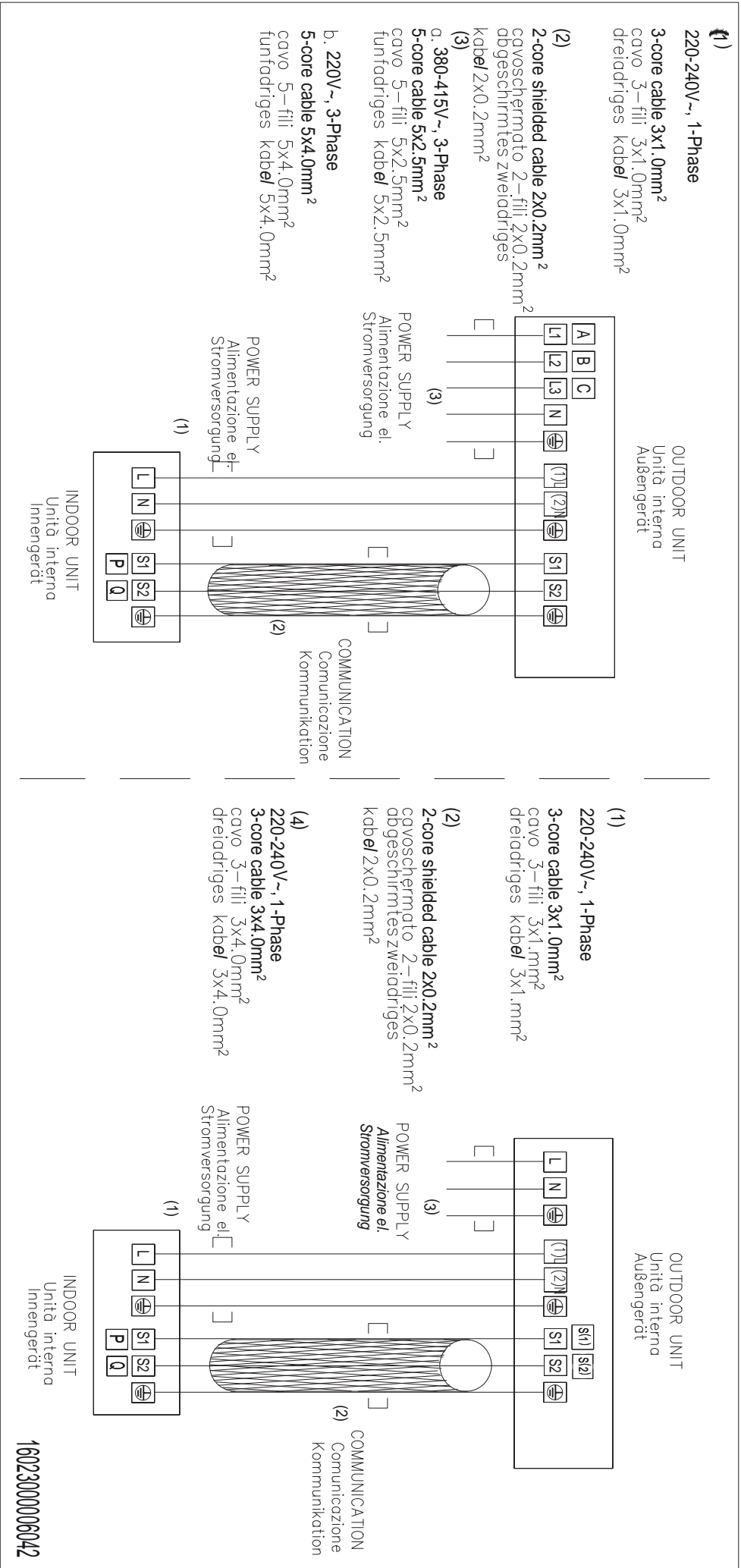

16022500003723

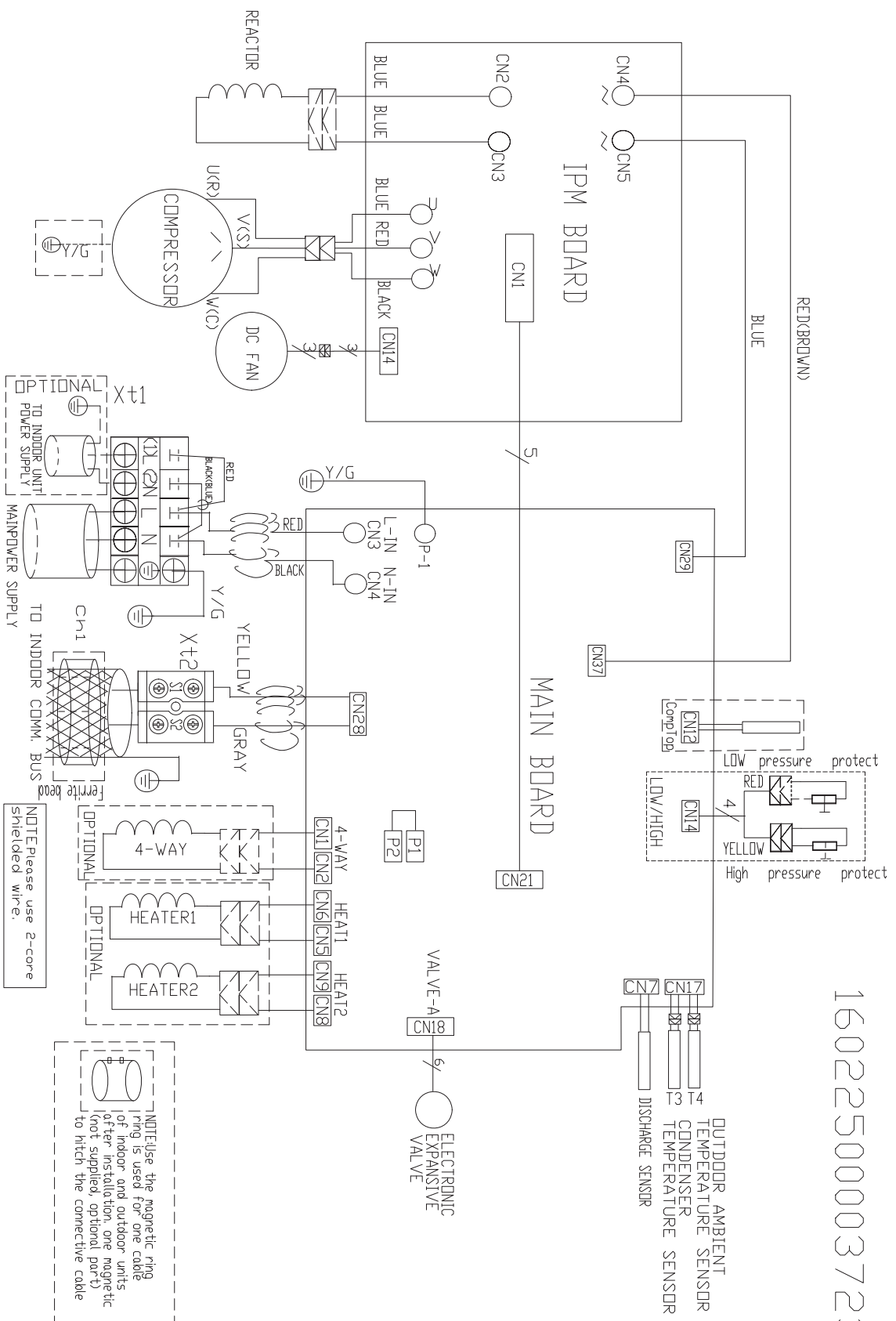

NOTE: Use the magnetic ring of indoor and outdoor units after installation, one magnetic (not supplied, optional part) to match the connective cable

NOTE: Please use 2-core shielded wire.

Clivet: Via Camp Long, 25 Villapiera 20022 Feltrè (TV) Italy
 Web: www.clivet.com Email: info@clivet.it Tel.: +39 0439 3131 -
 Fax: +39 0439 313300

Series: MC2-Y Grandezza/Size: 70M
 Schema/Wiring Diagram: EU-KFR71W/BP3T1N8 Tensione/Supply: 230/1/50

16022700002412

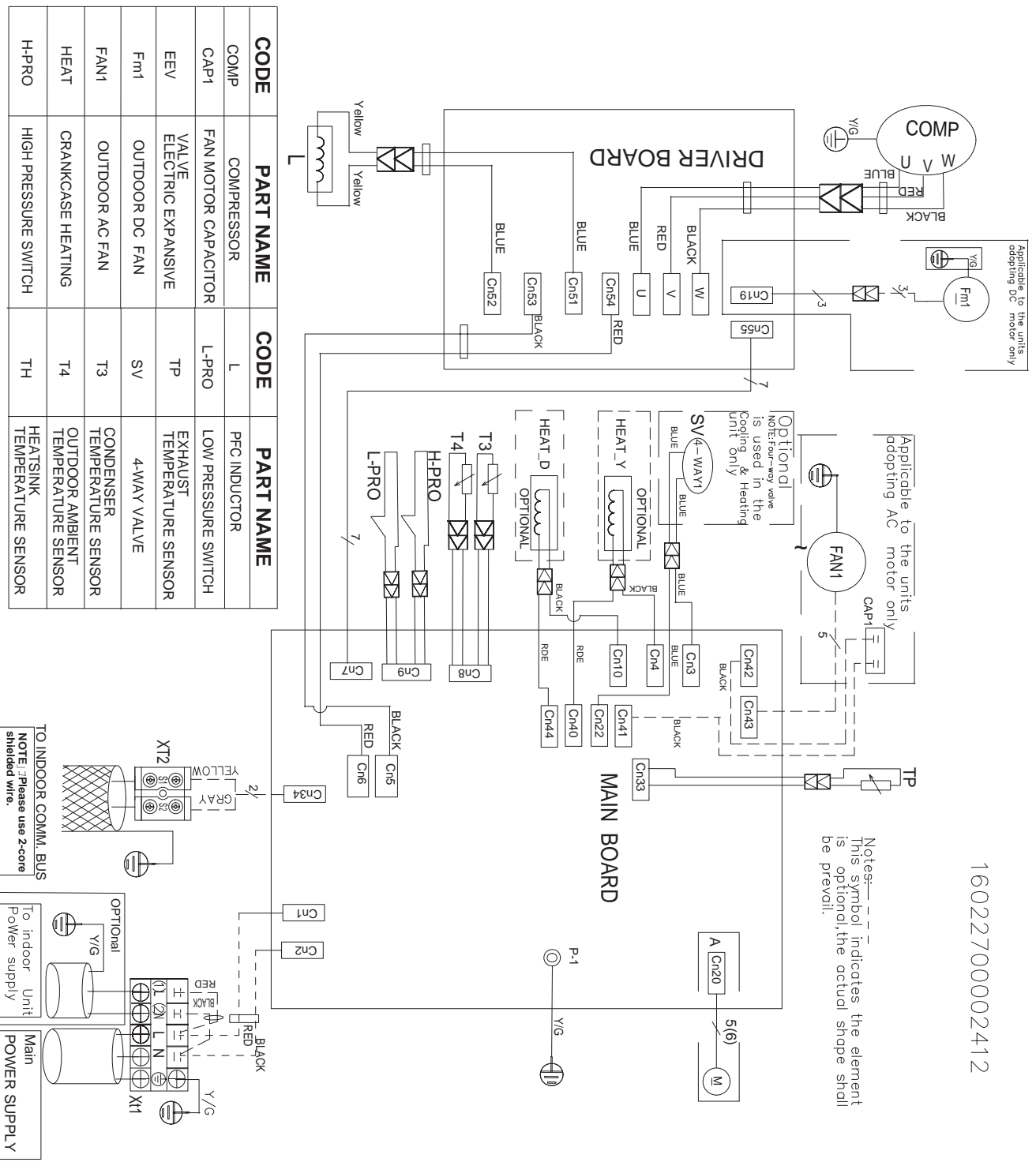

CODE	PART NAME	CODE	PART NAME
COMP	COMPRESSOR	L	PFC INDUCTOR
CAP1	FAN MOTOR CAPACITOR	L-PRO	LOW PRESSURE SWITCH
EEV	VALVE ELECTRIC EXPANSIVE	TP	EXHAUST TEMPERATURE SENSOR
Fm1	OUTDOOR DC FAN	SV	4-WAY VALVE
FAN1	OUTDOOR AC FAN	T3	CONDENSER TEMPERATURE SENSOR
HEAT	CRANKCASE HEATING	T4	OUTDOOR AMBIENT TEMPERATURE SENSOR
H-PRO	HIGH PRESSURE SWITCH	TH	HEATSINK TEMPERATURE SENSOR

CLIVET
 A Group Company of **Midea**

Clivet: Via Camp Long, 25 Villapalera 32032 Feltrè (BL) Italy
 Web: www.clivet.com Email: info@clivet.it Tel.: +39 0439 3131 -
 Fax: +39 0439 313300

Series/Size: **MC2-Y** **105M**
 Schema/Wiring Diagram
 WD-EUKFR105WBP3T1N1D30
 Transome/Supply: **230/1/50**

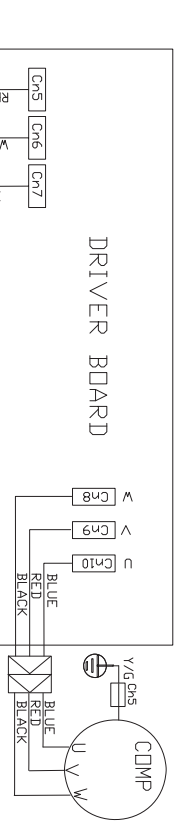

WIRING DIAGRAM (OUTDOOR UNIT)
16022500002224

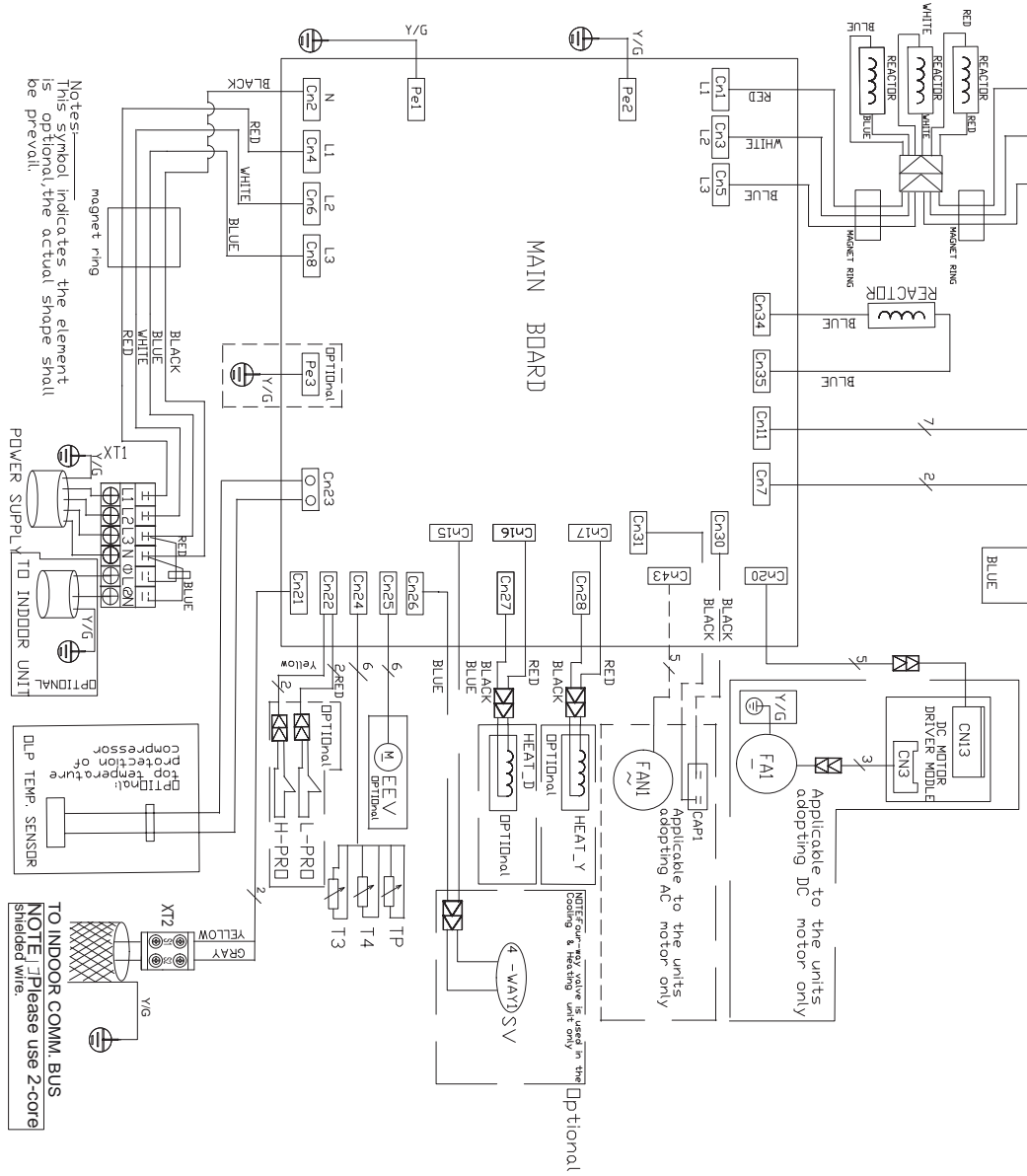

Notes:
This symbol indicates the element is optional; the actual shape shall be prevail.

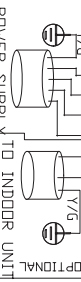

CODE	PART NAME
CDMP	COMPRESSOR
CAP1	FAN MOTOR CAPACITOR
EEV	ELECTRIC EXPANSIVE VALVE
FAN1	OUTDOOR DC FAN
FAN1	OUTDOOR AC FAN
HEAT	CRANKCASE HEATING
H-PRD	HIGH PRESSURE SWITCH
L	Reactor
L-PRD	LDW PRESSURE SWITCH
SV	4-WAY VALVE
TP	EXHAUST TEMPERATURE SENSOR
T3	CONDENSER TEMPERATURE SENSOR
T4	OUTDOOR AMBIENT TEMPERATURE SENSOR

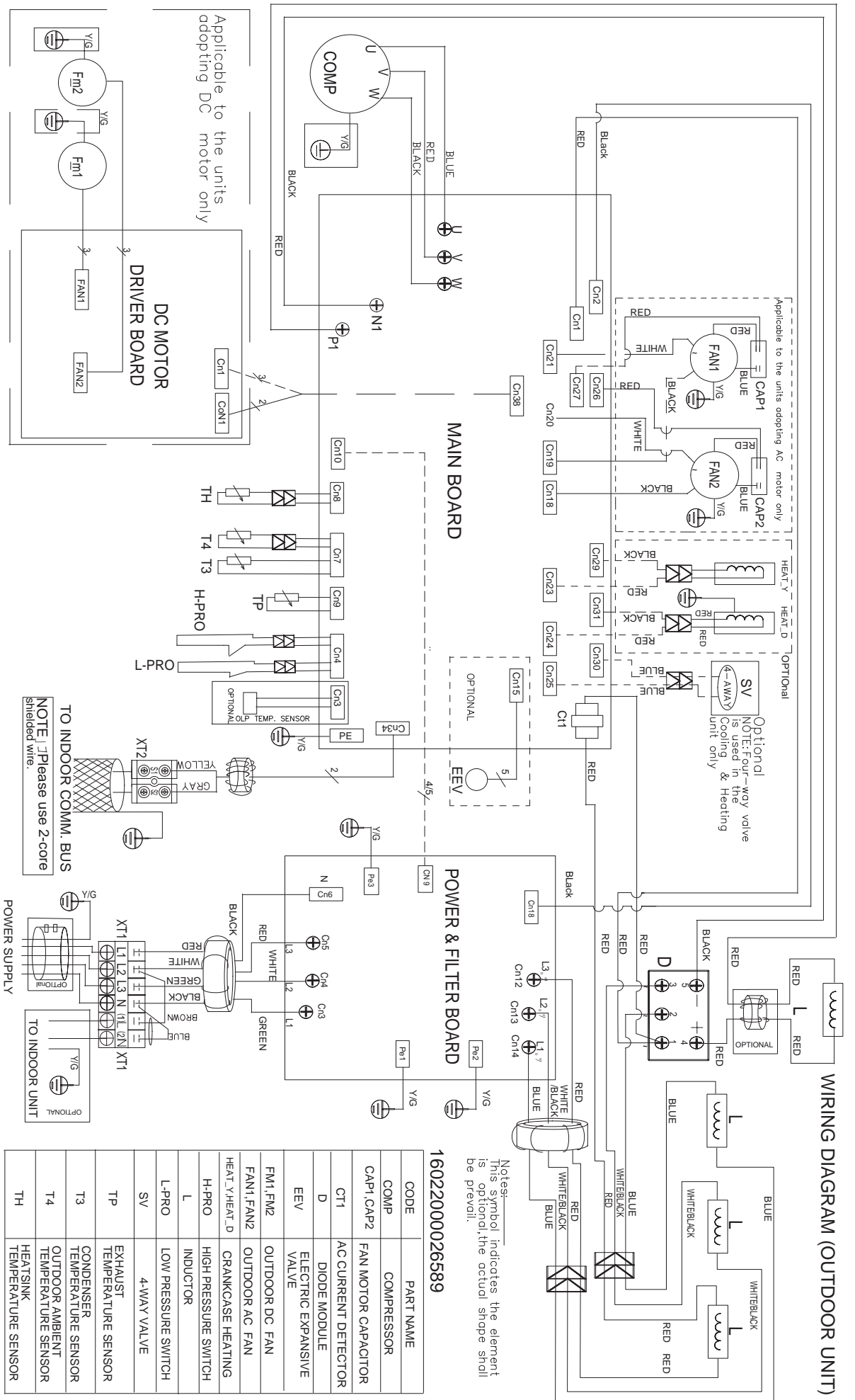

CODE	PART NAME
COMP	COMPRESSOR
CAP1,CAP2	FAN MOTOR CAPACITOR
CT1	AC CURRENT DETECTOR
D	DIODE MODULE
EEV	ELECTRIC EXPANSIVE VALVE
FM1,FM2	OUTDOOR DC FAN
FAN1,FAN2	OUTDOOR AC FAN
HEAT_V/HEAT_D	CRANKCASE HEATING
H-PRO	HIGH PRESSURE SWITCH
L	INDUCTOR
L-PRO	LOW PRESSURE SWITCH
SV	4-WAY VALVE
TP	EXHAUST TEMPERATURE SENSOR
T3	CONDENSER TEMPERATURE SENSOR
T4	OUTDOOR AMBIENT TEMPERATURE SENSOR
TH	HEATSINK TEMPERATURE SENSOR

16022000026589

CLIVET A Group Company of
Midea

Clivet: Via Camp Long, 25 Villapiera 32022 Feltrè (BL) Italy
 Web: www.clivet.com Email: info@clivet.it Tel.: +39 0439 3131 -
 Fax: +39 0439 313300

Series/Model: **MC2-Y**

Schema/Wiring Diagram: **EU-KFR160W/BP3T1S1N1-E30 (RD0+R32).JD.F.W.WXWKB.MP-1**

Grandezza/Size: **140T-160T**

Tensione/Supply: **400/3/50+N**



DECLARATION OF CONFORMITY EU

DICHIARAZIONE DI CONFORMITÀ UE
KONFORMITÄT SERKLÄRUNG EU
DECLARATION DE CONFORMITE EU
DECLARACIÓN DE CONFORMIDAD EU

WE DECLARE UNDER OUR SOLE RESPONSIBILITY THAT THE MACHINE

DICHIARIAMO SOTTO LA NOSTRA SOLA RESPONSABILITÀ CHE LA MACCHINA
WIR ERKLÄREN EIGENVERANTWORTLICH, DASS DIE MASCHINE
NOUS DÉCLARONS SOUS NOTRE SEULE RESPONSABILITÉ QUE LA MACHINE
EL FABRICANTE DECLARA BAJO SU EXCLUSIVA RESPONSABILIDAD QUE LA MÁQUINA

CATEGORY **DIRECT EXPANSION TERMINALS - Heat pump**
CATEGORIA **TERMINALI AD ESPANSIONE DIRETTA - Pompa di calore**
KATEGORIE **DIREKTVERDAMPFUNGSGERÄTE - Wärmepumpe**
CATEGORIE **TERMINAUX À DÉTENTE DIRECTE - Pompe à chaleur**
CATEGORIA **TERMINALES POR EXPANSIÓN DIRECTA - Bomba de calor**

TYPE / TIPO / TYP / TYPE / TIPO

IA2-XY 70M

- **COMPLIES WITH THE FOLLOWING EEC DIRECTIVES, INCLUDING THE MOST RECENT AMENDMENTS, AND THE RELEVANT NATIONAL HARMONISATION LEGISLATION CURRENTLY IN FORCE:**
- RISULTA IN CONFORMITÀ CON QUANTO PREVISTO DALLE SEGUENTI DIRETTIVE CEE, COMPRESSE LE ULTIME MODIFICHE, E CON LA RELATIVA LEGISLAZIONE NAZIONALE DI RECEPIMENTO:
- DEN IN DEN FOLGENDEN EWG-RICHTLINIEN VORGESEHENEN VORSCHRIFTEN, EINSCHLIEßLICH DER LETZTEN ÄNDERUNGEN, SOWIE DEN ANGEWANDTEN LANDESGESETZEN ENTSPRICHT:
- EST CONFORME AUX DIRECTIVES CEE SUIVANTES, Y COMPRIS LES DERNIÈRES MODIFICATIONS, ET À LA LÉGISLATION NATIONALE D'ACCUEIL CORRESPONDANTE:
- ES CONFORME A LAS SIGUIENTES DIRECTIVAS CEE, INCLUIDAS LAS ÚLTIMAS MODIFICACIONES, Y A LA RELATIVA LEGISLACIÓN NACIONAL DE RECEPCIÓN:

- 2014/35/EC** **low voltage directive**
direttiva bassa tensione
Bestimmungen der Niederspannungsrichtlinie
directive basse tension
directiva de baja tensión
- 2014/30/UE** **electromagnetic compatibility**
compatibilità elettromagnetica
Elektromagnetische Verträglichkeit
compatibilité électromagnétique
compatibilidad electromagnética
- 2009/125/CE** **Ecodesign** /Progettazione ecocompatibile / Ecodesign / Éco-conception / Ecodiseño
- 2011/65/UE** **RoHs**

-Unit manufactured and tested according to the followings Standards: EN 55014-1 :2017 EN 55014-2 :2015
-Unità costruita e collaudata in conformità alle seguenti Normative: EN 61000-3-3 :2013 EN 61000-3-2 :2014
-Unité construite et testée en conformité avec les Réglementations suivantes EN 60335-2-40 :2003+A11 :2004+A12 :2005+A1 :2006+A2 :2009+A13 :2012
-Unidad construida y probada de acuerdo con las siguientes Normativas EN 60335-1 :2012+A11 :2014 EN 62233 :2008
-Gebautes und geprüftes Gerät nach folgenden Normen EN 62321-1 :2013 EN 62321-2 :2014 EN 62321-3-1 :2014
EN 62321-4 :2014 EN 62321-5 :2014 EN 62321-6 :2015
EN 62321-7-1 :2015 EN 62321 :2009

-Responsible to constitute the technical file is the company n° 00708410253 and registered at the Chamber of Commerce of Belluno Italy
-Responsabile a costituire il fascicolo tecnico è la società n° 00708410253 registrata presso la Camera di Commercio di Belluno Italia
-Verantwortliche für die technischen Unterlagen zusammenstellen n° 00708410253 ist das Unternehmen bei der Handelskammer von Belluno Italien registriert
-Responsable pour compiler le dossier technique est la société n° 00708410253 enregistrée à la Chambre de Commerce de Belluno en Italie
-Encargado de elaborar el expediente técnico es la empresa N° 00708410253 registrada en la Cámara de Comercio de Belluno Italia

FELTRE, 20/09/2018
NAME / NOME / VORNAME / PRÉNOM / NOMBRE
SURNAME / COGNOME / ZUNAME / NOM / APELLIDOS
COMPANY POSITION / POSIZIONE / BETRIEBSPOSITION / FONCTION / CARGO
STEFANO BELLÒ
LEGALE RAPPRESENTANTE



DECLARATION OF CONFORMITY EU

DICHIARAZIONE DI CONFORMITÀ UE
KONFORMITÄT SERKLÄRUNG EU
DECLARATION DE CONFORMITE EU
DECLARACIÓN DE CONFORMIDAD EU

WE DECLARE UNDER OUR SOLE RESPONSIBILITY THAT THE MACHINE

DICHIARIAMO SOTTO LA NOSTRA SOLA RESPONSABILITÀ CHE LA MACCHINA
WIR ERKLÄREN EIGENVERANTWORTLICH, DASS DIE MASCHINE
NOUS DÉCLARONS SOUS NOTRE SEULE RESPONSABILITÉ QUE LA MACHINE
EL FABRICANTE DECLARA BAJO SU EXCLUSIVA RESPONSABILIDAD QUE LA MÁQUINA

CATEGORY **DIRECT EXPANSION TERMINALS - Heat pump**
CATEGORIA **TERMINALI AD ESPANSIONE DIRETTA - Pompa di calore**
KATEGORIE **DIREKTVERDAMPFUNGSGERÄTE - Wärmepumpe**
CATEGORIE **TERMINAUX À DÉTENTE DIRECTE - Pompe à chaleur**
CATEGORIA **TERMINALES POR EXPANSIÓN DIRECTA - Bomba de calor**

TYPE / TIPO / TYP / TYPE / TIPO

IA2-XY 105M

- **COMPLIES WITH THE FOLLOWING EEC DIRECTIVES, INCLUDING THE MOST RECENT AMENDMENTS, AND THE RELEVANT NATIONAL HARMONISATION LEGISLATION CURRENTLY IN FORCE:**
- RISULTA IN CONFORMITÀ CON QUANTO PREVISTO DALLE SEGUENTI DIRETTIVE CEE, COMPRESI LE ULTIME MODIFICHE, E CON LA RELATIVA LEGISLAZIONE NAZIONALE DI RECEPIMENTO:
- DEN IN DEN FOLGENDEN EWG-RICHTLINIEN VORGESEHENEN VORSCHRIFTEN, EINSCHLIEßLICH DER LETZTEN ÄNDERUNGEN, SOWIE DEN ANGEWANDTEN LANDESGESETZEN ENTSPRICHT:
- EST CONFORME AUX DIRECTIVES CEE SUIVANTES, Y COMPRIS LES DERNIÈRES MODIFICATIONS, ET À LA LÉGISLATION NATIONALE D'ACCUEIL CORRESPONDANTE:
- ES CONFORME A LAS SIGUIENTES DIRECTIVAS CEE, INCLUIDAS LAS ÚLTIMAS MODIFICACIONES, Y A LA RELATIVA LEGISLACIÓN NACIONAL DE RECEPCIÓN:

- 2014/35/EC** **low voltage directive**
direttiva bassa tensione
Bestimmungen der Niederspannungsrichtlinie
directive basse tension
directiva de baja tensión
- 2014/30/UE** **electromagnetic compatibility**
compatibilità elettromagnetica
Elektromagnetische Verträglichkeit
compatibilité électromagnétique
compatibilidad electromagnética
- 2009/125/CE** **Ecodesign** /Progettazione ecocompatibile / Ecodesign / Éco-conception / Ecodiseño
- 2011/65/UE** **RoHs**

-Unit manufactured and tested according to the followings Standards: EN55014-1 :2006+A1 :2009+A2 :2011 EN 55014-2 :2015
EN 61000-3-2 :2014 EN 61000-3-3 :2013
-Unità costruita e collaudata in conformità alle seguenti Normative: EN 61000-3-12 :2011 EN 61000-3-11 :2000
-Unité construite et testée en conformité avec les Réglementations suivantes EN 60335-2-40 :2003+A11 :2004+A12 :2005+A1 :2006+A2 :2009+A13 :2012
-Unidad construida y probada de acuerdo con las siguientes Normativas EN 60335-1 :2012+A11 :2014 EN 62233 :2008
-Gebautes und geprüftes Gerät nach folgenden Normen EN 62321-1 :2013 EN 62321-2 :2014 EN 62321-3-1 :2014
EN 62321-4 :2014 EN 62321-5 :2014 EN 62321-6 :2015
EN 62321-7-1 :2015 EN 62321 :2009

-Responsible to constitute the technical file is the company n° 00708410253 and registered at the Chamber of Commerce of Belluno Italy
-Responsabile a costituire il fascicolo tecnico è la società n° 00708410253 registrata presso la Camera di Commercio di Belluno Italia
-Verantwortliche für die technischen Unterlagen zusammenstellen n° 00708410253 ist das Unternehmen bei der Handelskammer von Belluno Italien registriert
-Responsable pour compiler le dossier technique est la société n° 00708410253 enregistrée à la Chambre de Commerce de Belluno en Italie
-Encargado de elaborar el expediente técnico es la empresa N° 00708410253 registrada en la Cámara de Comercio de Belluno Italia

FELTRE, 20/09/2018
NAME / NOME / VORNAME / PRÉNOM / NOMBRE **STEFANO**
SURNAME / COGNOME / ZUNAME / NOM / APELLIDOS **BELLÒ**
COMPANY POSITION / POSIZIONE / BETRIEBSPOSITION / FONCTION / CARGO **LEGALE RAPPRESENTANTE**



DECLARATION OF CONFORMITY EU

DICHIARAZIONE DI CONFORMITÀ UE
KONFORMITÄT SERKLÄRUNG EU
DECLARATION DE CONFORMITE EU
DECLARACIÓN DE CONFORMIDAD EU

WE DECLARE UNDER OUR SOLE RESPONSIBILITY THAT THE MACHINE

DICHIARIAMO SOTTO LA NOSTRA SOLA RESPONSABILITÀ CHE LA MACCHINA
WIR ERKLÄREN EIGENVERANTWORTLICH, DASS DIE MASCHINE
NOUS DÉCLARONS SOUS NOTRE SEULE RESPONSABILITÉ QUE LA MACHINE
EL FABRICANTE DECLARA BAJO SU EXCLUSIVA RESPONSABILIDAD QUE LA MÁQUINA

CATEGORY DIRECT EXPANSION TERMINALS - Heat pump
CATEGORIA TERMINALI AD ESPANSIONE DIRETTA - Pompa di calore
KATEGORIE DIREKTVERDAMPFUNGSGERÄTE - Wärmepumpe
CATEGORIE TERMINAUX À DÉTENTE DIRECTE - Pompe à chaleur
CATEGORIA TERMINALES POR EXPANSIÓN DIRECTA - Bomba de calor

TYPE / TIPO / TYP / TYPE / TIPO

IA2-XY 140M IA2-XY 160M

- **COMPLIES WITH THE FOLLOWING EEC DIRECTIVES, INCLUDING THE MOST RECENT AMENDMENTS, AND THE RELEVANT NATIONAL HARMONISATION LEGISLATION CURRENTLY IN FORCE:**
- RISULTA IN CONFORMITÀ CON QUANTO PREVISTO DALLE SEGUENTI DIRETTIVE CEE, COMPRESSE LE ULTIME MODIFICHE, E CON LA RELATIVA LEGISLAZIONE NAZIONALE DI RECEPIMENTO:
- DEN IN DEN FOLGENDEN EWG-RICHTLINIEN VORGESEHENEN VORSCHRIFTEN, EINSCHLIEßLICH DER LETZTEN ÄNDERUNGEN, SOWIE DEN ANGEWANDTEN LANDESGESETZEN ENTSPRICHT:
- EST CONFORME AUX DIRECTIVES CEE SUIVANTES, Y COMPRIS LES DERNIÈRES MODIFICATIONS, ET À LA LÉGISLATION NATIONALE D'ACCUEIL CORRESPONDANTE:
- ES CONFORME A LAS SIGUIENTES DIRECTIVAS CEE, INCLUIDAS LAS ÚLTIMAS MODIFICACIONES, Y A LA RELATIVA LEGISLACIÓN NACIONAL DE RECEPCIÓN:

- 2014/35/EC** **low voltage directive**
direttiva bassa tensione
Bestimmungen der Niederspannungsrichtlinie
directive basse tension
directiva de baja tensión
- 2014/30/UE** **electromagnetic compatibility**
compatibilità elettromagnetica
Elektromagnetische Verträglichkeit
compatibilité électromagnétique
compatibilidad electromagnética
- 2009/125/CE** **Ecodesign** /Progettazione ecocompatibile / Ecodesign / Éco-conception / Ecodiseño
- 2011/65/UE** **RoHs**

-Unit manufactured and tested according to the followings Standards: EN 55014-1 :2017 EN 55014-2 :2015
-Unità costruita e collaudata in conformità alle seguenti Normative: EN 61000-3-3 :2013 EN 61000-3-2 :2014
-Unité construite et testée en conformité avec les Réglementations suivantes EN 60335-2-40 :2003+A11 :2004+A12 :2005+A1 :2006+A2 :2009+A13 :2012
-Unidad construida y probada de acuerdo con las siguientes Normativas EN 60335-1 :2012+A11 :2014+A13 :2017 EN 62233 :2008
-Gebautes und geprüftes Gerät nach folgenden Normen EN 62321-1 :2013 EN 62321-2 :2014 EN 62321-3-1 :2014
EN 62321-4 :2014 EN 62321-5 :2014 EN 62321-6 :2015
EN 62321-7-1 :2015 EN 62321 :2009

-Responsible to constitute the technical file is the company n° 00708410253 and registered at the Chamber of Commerce of Belluno Italy
-Responsabile a costituire il fascicolo tecnico è la società n° 00708410253 registrata presso la Camera di Commercio di Belluno Italia
-Verantwortliche für die technischen Unterlagen zusammenstellen n° 00708410253 ist das Unternehmen bei der Handelskammer von Belluno Italien registriert
-Responsable pour compiler le dossier technique est la société n° 00708410253 enregistrée à la Chambre de Commerce de Belluno en Italie
-Encargado de elaborar el expediente técnico es la empresa N° 00708410253 registrada en la Cámara de Comercio de Belluno Italia

FELTRE, 20/09/2018
NAME / NOME / VORNAME / PRÉNOM / NOMBRE
SURNAME / COGNOME / ZUNAME / NOM / APELLIDOS
COMPANY POSITION / POSIZIONE / BETRIEBSPOSITION / FONCTION / CARGO
STEFANO BELLÒ
LEGALE RAPPRESENTANTE



DECLARATION OF CONFORMITY EU

DICHIARAZIONE DI CONFORMITÀ UE
KONFORMITÄT SERKLÄRUNG EU
DECLARATION DE CONFORMITE EU
DECLARACIÓN DE CONFORMIDAD EU

WE DECLARE UNDER OUR SOLE RESPONSIBILITY THAT THE MACHINE

DICHIARIAMO SOTTO LA NOSTRA SOLA RESPONSABILITÀ CHE LA MACCHINA
WIR ERKLÄREN EIGENVERANTWORTLICH, DASS DIE MASCHINE
NOUS DÉCLARONS SOUS NOTRE SEULE RESPONSABILITÉ QUE LA MACHINE
EL FABRICANTE DECLARA BAJO SU EXCLUSIVA RESPONSABILIDAD QUE LA MÁQUINA

CATEGORY	CONDENSING UNITS - Heat pump
CATEGORIA	MOTOCONDENSANTI - Pompa di calore
KATEGORIE	VERFLÜSSIGUNGSEINHEITEN - Wärmepumpe
CATEGORIE	GROUPES DE CONDENSATION - Pompe à chaleur
CATEGORIA	MOTOCONDENSADORAS - Bomba de calor

TYPE / TIPO / TYP / TYPE / TIPO

MC2-Y 105T MC2-Y 70M

- **COMPLIES WITH THE FOLLOWING EEC DIRECTIVES, INCLUDING THE MOST RECENT AMENDMENTS, AND THE RELEVANT NATIONAL HARMONISATION LEGISLATION CURRENTLY IN FORCE:**
 - RISULTA IN CONFORMITÀ CON QUANTO PREVISTO DALLE SEGUENTI DIRETTIVE CEE, COMPRESSE LE ULTIME MODIFICHE, E CON LA RELATIVA LEGISLAZIONE NAZIONALE DI RECEPIMENTO:
 - DEN IN DEN FOLGENDEN EWG-RICHTLINIEN VORGESEHENEN VORSCHRIFTEN, EINSCHLIEßLICH DER LETZTEN ÄNDERUNGEN, SOWIE DEN ANGEWANDTEN LANDESGESETZEN ENTSPRICHT:
 - EST CONFORME AUX DIRECTIVES CEE SUIVANTES, Y COMPRIS LES DERNIÈRES MODIFICATIONS, ET À LA LÉGISLATION NATIONALE D'ACCUEIL CORRESPONDANTE:
 - ES CONFORME A LAS SIGUIENTES DIRECTIVAS CEE, INCLUIDAS LAS ÚLTIMAS MODIFICACIONES, Y A LA RELATIVA LEGISLACIÓN NACIONAL DE RECEPCIÓN:
- 2014/35/EC** **low voltage directive**
direttiva bassa tensione
Bestimmungen der Niederspannungsrichtlinie
directive basse tension
directiva de baja tensión
- 2014/30/UE** **electromagnetic compatibility**
compatibilità elettromagnetica
Elektromagnetische Verträglichkeit
compatibilité électromagnétique
compatibilidad electromagnética
- 2009/125/CE** **Ecodesign** /Progettazione ecocompatibile / Ecodesign / Éco-conception / Ecodiseño
- 2011/65/UE** **RoHS**

-Unit manufactured and tested according to the followings Standards: EN 55014-1 :2017 EN 55014-2 :2015
-Unità costruita e collaudata in conformità alle seguenti Normative: EN 61000-3-2 :2014 EN 61000-3-3 :2013
-Unité construite et testée en conformité avec les Réglementations suivantes EN 60335-2-40 :2003+A11 :2004+A12 :2005+A1 :2006+A2 :2009+A13 :2012
-Unidad construida y probada de acuerdo con las siguientes Normativas EN 60335-1 :2012+A11 :2014 EN 62233 :2008
-Gebautes und geprüftes Gerät nach folgenden Normen EN 62321-1 :2013 EN 62321-2 :2014 EN 62321-3-1 :2014
EN 62321-4 :2014 EN 62321-5 :2014 EN 62321-6 :2015
EN 62321-7-1 :2015 EN 62321 :2009

-Responsible to constitute the technical file is the company n°00708410253 and registered at the Chamber of Commerce of Belluno Italy
-Responsabile a costituire il fascicolo tecnico è la società n° 00708410253 registrata presso la Camera di Commercio di Belluno Italia
-Verantwortliche für die technischen Unterlagen zusammenstellen n°00708410253 ist das Unternehmen bei der Handelskammer von Belluno Italien registriert
-Responsable pour compiler le dossier technique est la société n°00708410253 enregistrée à la Chambre de Commerce de Belluno en Italie
-Encargado de elaborar el expediente técnico es la empresa N° 00708410253 registrada en la Cámara de Comercio de Belluno Italia

FELTRE, 20/09/2018

NAME / NOME / VORNAME / PRÉNOM / NOMBRE
SURNAME / COGNOME / ZUNAME / NOM / APELLIDOS
COMPANY POSITION / POSIZIONE / BETRIEBSPOSITION / FONCTION / CARGO

STEFANO BELLÒ
LEGALE RAPPRESENTANTE



DECLARATION OF CONFORMITY EU

DICHIARAZIONE DI CONFORMITÀ UE
KONFORMITÄT SERKLÄRUNG EU
DECLARATION DE CONFORMITE EU
DECLARACIÓN DE CONFORMIDAD EU

WE DECLARE UNDER OUR SOLE RESPONSIBILITY THAT THE MACHINE

DICHIARIAMO SOTTO LA NOSTRA SOLA RESPONSABILITÀ CHE LA MACCHINA
WIR ERKLÄREN EIGENVERANTWORTLICH, DASS DIE MASCHINE
NOUS DÉCLARONS SOUS NOTRE SEULE RESPONSABILITÉ QUE LA MACHINE
EL FABRICANTE DECLARA BAJO SU EXCLUSIVA RESPONSABILIDAD QUE LA MÁQUINA

CATEGORY	CONDENSING UNITS - Heat pump
CATEGORIA	MOTOCONDENSANTI - Pompa di calore
KATEGORIE	VERFLÜSSIGUNGSEINHEITEN - Wärmepumpe
CATEGORIE	GROUPES DE CONDENSATION - Pompe à chaleur
CATEGORIA	MOTOCONDENSADORAS - Bomba de calor

TYPE / TIPO / TYP / TYPE / TIPO

MC2-Y 105M

- **COMPLIES WITH THE FOLLOWING EEC DIRECTIVES, INCLUDING THE MOST RECENT AMENDMENTS, AND THE RELEVANT NATIONAL HARMONISATION LEGISLATION CURRENTLY IN FORCE:**
 - RISULTA IN CONFORMITÀ CON QUANTO PREVISTO DALLE SEGUENTI DIRETTIVE CEE, COMPRESSE LE ULTIME MODIFICHE, E CON LA RELATIVA LEGISLAZIONE NAZIONALE DI RECEPIMENTO:
 - DEN IN DEN FOLGENDEN EWG-RICHTLINIEN VORGESEHENEN VORSCHRIFTEN, EINSCHLIEßLICH DER LETZTEN ÄNDERUNGEN, SOWIE DEN ANGEWANDTEN LANDESGESETZEN ENTSPRICHT:
 - EST CONFORME AUX DIRECTIVES CEE SUIVANTES, Y COMPRIS LES DERNIÈRES MODIFICATIONS, ET À LA LÉGISLATION NATIONALE D'ACCUEIL CORRESPONDANTE:
 - ES CONFORME A LAS SIGUIENTES DIRECTIVAS CEE, INCLUIDAS LAS ÚLTIMAS MODIFICACIONES, Y A LA RELATIVA LEGISLACIÓN NACIONAL DE RECEPCIÓN:
- 2014/35/EC** **low voltage directive**
direttiva bassa tensione
Bestimmungen der Niederspannungsrichtlinie
directive basse tension
directiva de baja tensión
- 2014/30/UE** **electromagnetic compatibility**
compatibilità elettromagnetica
Elektromagnetische Verträglichkeit
compatibilité électromagnétique
compatibilidad electromagnética
- 2009/125/CE** **Ecodesign /Progettazione ecocompatibile / Ecodesign / Éco-conception / Ecodiseño**
- 2011/65/UE** **RoHS**

-Unit manufactured and tested according to the followings Standards: EN 55014-1 :2006+A1 :2009+A2 :2011 EN 55014-2 :2015
-Unità costruita e collaudata in conformità alle seguenti Normative: EN 61000-3-2 :2014 EN 61000-3-3 :2013 EN 61000-3-12 :2011
-Unité construite et testée en conformité avec les Réglementations suivantes EN 61000-3-11 :2000
-Unidad construida y probada de acuerdo con las siguientes Normativas EN 60335-2-40 :2003+A11 :2004+A12 :2005+A1 :2006+A2 :2009+A13 :2012
-Gebautes und geprüftes Gerät nach folgenden Normen EN 60335-1 :2012+A11 :2014 EN 62233 :2008
EN 62321-1 :2013 EN 62321-2 :2014 EN 62321-3-1 :2014
EN 62321-4 :2014 EN 62321-5 :2014 EN 62321-6 :2015
EN 62321-7-1 :2015 EN 62321 :2009

-Responsible to constitute the technical file is the company n° 00708410253 and registered at the Chamber of Commerce of Belluno Italy
-Responsabile a costituire il fascicolo tecnico è la società n° 00708410253 registrata presso la Camera di Commercio di Belluno Italia
-Verantwortliche für die technischen Unterlagen zusammenstellen n° 00708410253 ist das Unternehmen bei der Handelskammer von Belluno Italien registriert
-Responsable pour compiler le dossier technique est la société n° 00708410253 enregistrée à la Chambre de Commerce de Belluno en Italie
-Encargado de elaborar el expediente técnico es la empresa N° 00708410253 registrada en la Cámara de Comercio de Belluno Italia

FELTRE, 20/09/2018

NAME / NOME / VORNAME / PRÉNOM / NOMBRE
SURNAME / COGNOME / ZUNAME / NOM / APELLIDOS
COMPANY POSITION / POSIZIONE / BETRIEBSPOSITION / FONCTION / CARGO

STEFANO
BELLÒ
LEGALE RAPPRESENTANTE



DECLARATION OF CONFORMITY EU

DICHIARAZIONE DI CONFORMITÀ UE
KONFORMITÄT SERKLÄRUNG EU
DECLARATION DE CONFORMITE EU
DECLARACIÓN DE CONFORMIDAD EU

WE DECLARE UNDER OUR SOLE RESPONSIBILITY THAT THE MACHINE

DICHIARIAMO SOTTO LA NOSTRA SOLA RESPONSABILITÀ CHE LA MACCHINA
WIR ERKLÄREN EIGENVERANTWORTLICH, DASS DIE MASCHINE
NOUS DÉCLARONS SOUS NOTRE SEULE RESPONSABILITÉ QUE LA MACHINE
EL FABRICANTE DECLARA BAJO SU EXCLUSIVA RESPONSABILIDAD QUE LA MÁQUINA

CATEGORY	CONDENSING UNITS - Heat pump
CATEGORIA	MOTOCONDENSANTI - Pompa di calore
KATEGORIE	VERFLÜSSIGUNGSEINHEITEN - Wärmepumpe
CATEGORIE	GROUPES DE CONDENSATION - Pompe à chaleur
CATEGORIA	MOTOCONDENSADORAS - Bomba de calor

TYPE / TIPO / TYP / TYPE / TIPO

MC2-Y 140T MC2-Y 160T

- **COMPLIES WITH THE FOLLOWING EEC DIRECTIVES, INCLUDING THE MOST RECENT AMENDMENTS, AND THE RELEVANT NATIONAL HARMONISATION LEGISLATION CURRENTLY IN FORCE:**
 - RISULTA IN CONFORMITÀ CON QUANTO PREVISTO DALLE SEGUENTI DIRETTIVE CEE, COMPRESSE LE ULTIME MODIFICHE, E CON LA RELATIVA LEGISLAZIONE NAZIONALE DI RECEPIMENTO:
 - DEN IN DEN FOLGENDEN EWG-RICHTLINIEN VORGESEHENEN VORSCHRIFTEN, EINSCHLIEßLICH DER LETZTEN ÄNDERUNGEN, SOWIE DEN ANGEWANDTEN LANDESGESETZEN ENTSPRICHT:
 - EST CONFORME AUX DIRECTIVES CEE SUIVANTES, Y COMPRIS LES DERNIÈRES MODIFICATIONS, ET À LA LÉGISLATION NATIONALE D'ACCUEIL CORRESPONDANTE:
 - ES CONFORME A LAS SIGUIENTES DIRECTIVAS CEE, INCLUIDAS LAS ÚLTIMAS MODIFICACIONES, Y A LA RELATIVA LEGISLACIÓN NACIONAL DE RECEPCIÓN:
-
- 2014/35/EC** **low voltage directive**
direttiva bassa tensione
Bestimmungen der Niederspannungsrichtlinie
directive basse tension
directiva de baja tensión
 - 2014/30/UE** **electromagnetic compatibility**
compatibilità elettromagnetica
Elektromagnetische Verträglichkeit
compatibilité électromagnétique
compatibilidad electromagnética
 - 2009/125/CE** **Ecodesign** /Progettazione ecocompatibile / Ecodesign / Éco-conception / Ecodiseño
 - 2011/65/UE** **RoHS**

-Unit manufactured and tested according to the followings Standards: EN 60335-2-40 :2003+A11 :2004+A12 :2005+A1 :2006+A2 :2009+A13 :2012
-Unità costruita e collaudata in conformità alle seguenti Normative: EN 60335-1 :2012+A11 :2014+A13 :2017 EN 62233 :2008
-Unité construite et testée en conformité avec les Réglementations suivantes EN 55014-1 :2017 EN 55014-2 :2015
-Unidad construida y probada de acuerdo con las siguientes Normativas EN 61000-3-2 :2014 EN 61000-3-3 :2013
-Gebautes und geprüftes Gerät nach folgenden Normen EN 62321-1 :2013 EN 62321-2 :2014 EN 62321-3-1 :2014
EN 62321-4 :2014 EN 62321-5 :2014 EN 62321-6 :2015
EN 62321-7-1 :2015 EN 62321 :2009

-Responsible to constitute the technical file is the company n°.00708410253 and registered at the Chamber of Commerce of Belluno Italy
-Responsabile a costituire il fascicolo tecnico è la società n° 00708410253 registrata presso la Camera di Commercio di Belluno Italia
-Verantwortliche für die technischen Unterlagen zusammenstellen n°.00708410253 ist das Unternehmen bei der Handelskammer von Belluno Italien registriert
-Responsable pour compiler le dossier technique est la société n°00708410253 enregistrée à la Chambre de Commerce de Belluno en Italie
-Encargado de elaborar el expediente técnico es la empresa N° 00708410253 registrada en la Cámara de Comercio de Belluno Italia

FELTRE, 20/09/2018

NAME / NOME / VORNAME / PRÉNOM / NOMBRE
SURNAME / COGNOME / ZUNAME / NOM / APELLIDOS
COMPANY POSITION / POSIZIONE / BETRIEBSPOSITION / FONCTION / CARGO

STEFANO
BELLÒ
LEGALE RAPPRESENTANTE

**CLIVET SPA**

Via Camp Lonc 25, Z.I. Villapaiera - 32032 Feltre (BL) - Italy
Tel. + 39 0439 3131 - Fax + 39 0439 313300 - info@clivet.it

CLIVET GROUP UK Limited

4 Kingdom Close, Segensworth East - Fareham, Hampshire - PO15 5TJ - United Kingdom
Tel. + 44 (0) 1489 572238 - Fax + 44 (0) 1489 573033 - enquiries@clivetgroup.co.uk

CLIVET GROUP UK Limited (Service Department)

Units F5&F6 Railway Triangle Ind Est, Walton Road - Portsmouth, Hampshire - PO6 1TG - United Kingdom
Tel. +44 (0) 2392 381235 - Fax. +44 (0) 2392 381243 - service@clivetgroup.co.uk

CLIVET ESPAÑA S.A.U.

C/ Bac de Roda, 36 - 08019 Barcelona - España
Tel: +34 93 8606248 - Fax +34 93 8855392 - info@clivet.es

Av.Manoteras Nº 38, Oficina C303 - 28050 Madrid - España
Tel. +34 91 6658280 - Fax +34 91 6657806 - info@clivetes

CLIVET GmbH (Hydronic and Applied Division)

Hummelsbütteler Steindamm 84, 22851 Norderstedt - Germany
Tel. + 49 (0) 40 32 59 57-0 - Fax + 49 (0) 40 32 59 57-194 - info.de@clivet.com

CLIVET GmbH (VRF, Residential and Lightcom Division)

Eisenstrasse 9c, 65428 Rüsselsheim/Frankfurt - Germany
Tel. + 49 (0) 6142 83594-0 - Fax + 49 (0) 6142 83594-20 - vrf.de@clivet.com

CLIVET RUSSIA

Elektrozavodskaya st. 24, office 509 - 107023, Moscow, Russia
Tel. + 74956462009 - Fax + 74956462009 - info.ru@clivet.com

CLIVET MIDEAST FZCO

Dubai Silicon Oasis (DSO), High Bay Complex, Office N. 20, PO BOX 342009, Dubai, UAE
Tel. + 9714 3208499 - Fax + 9714 3208216 - info@clivet.ae

CLIVET AIRCONDITIONING SYSTEMS PRIVATE LIMITED

501/502, Commercial-1, Kohinoor City, Old Premier Compound, Kirol Road, Off L B S Marg, Kurla West - Mumbai 400 070
- India info.in@clivet.cortm