



LIGHT COMMERCIAL R32

CASSETTE 650x650 Box-SL 2 Outdoor unit-SL 2

Only size 53M

TECHNICAL MANUAL

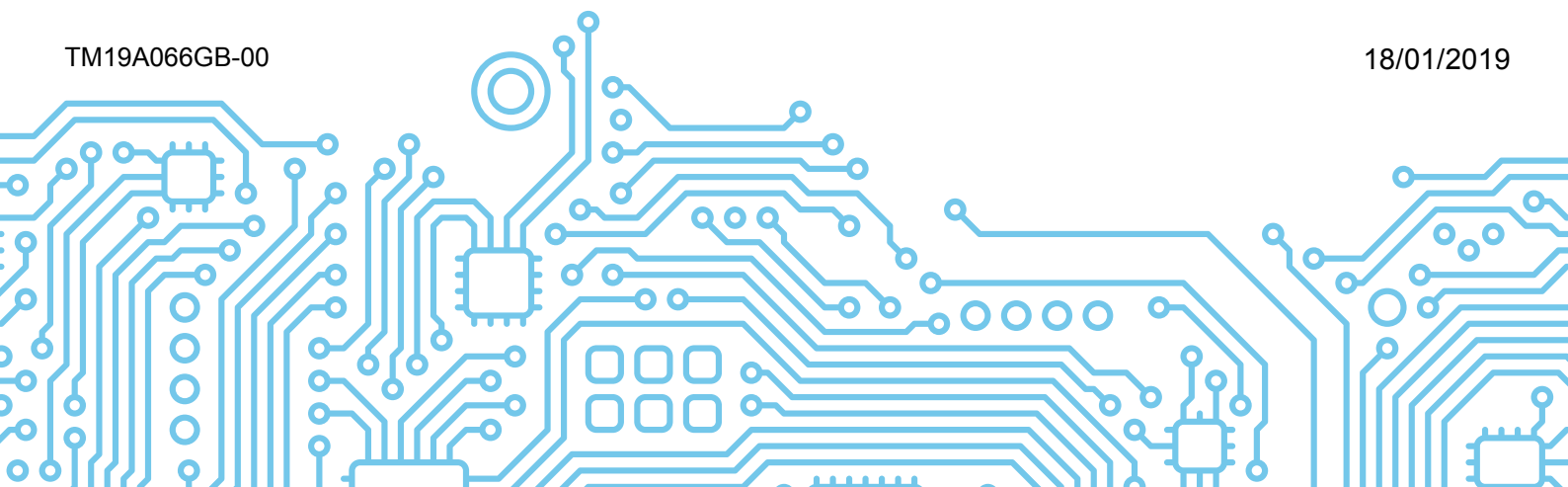

Table of Contents

Page

1. Specifications	3
1. Model Reference	
2. General Specifications	
3. Dimensional Drawings	
4. Centre of Gravity	
5. Electrical Wiring Diagrams	
6. Refrigerant Cycle Diagrams	
7. Capacity Tables	
8. Capacity Correction Factor for Height Difference	
9. Noise Criterion Curves	
10. Electrical Characteristics	
2. Product Features	28
1. Operation Modes and Functions	
2. Remote Controller Functions	
3. Installation	39
1. Installation Overview	
2. Location Selection	
3. Indoor Unit Installation	
4. Outdoor Unit Installation	
5. Drainage Pipe Installation	
6. Refrigerant Pipe Installation	
7. Vacuum Drying and Leakage checking	
8. Additional Refrigerant Charge	
9. Engineering of Insulation	
10. Engineering of Electrical Wiring	
11. Panel Installation	
12. Test Operation	

Specifications

Contents

1.	Model Reference.....	4
2.	General Specifications.....	5
3.	Dimensional Drawings.....	7
4.	Centre of Gravity.....	9
5.	Electrical Wiring Diagrams.....	10
6.	Refrigerant Cycle Diagrams.....	20
7.	Capacity Tables.....	21
8.	Capacity Correction Factor for Height Difference.....	24
9.	Noise Criterion Curves.....	25
10.	Electrical Characteristics.....	27

1. Model Reference

Refer to the following table to determine the specific indoor and outdoor unit model number of your purchased equipment.

Outdoor Unit Model	indoor Unit Model	Capacity (Btu/h)	Power Supply
MC2-Y 53M	IB2-XY 53M	18k	1 ϕ , 220~240V~, 50Hz

2. General Specifications

Indoor Model		IB2-XY 53M	
Outdoor Model		MC2-Y 53M	
Power supply (Indoor)	V- Ph-Hz	220~240-1-50	
Power supply (Outdoor)	V- Ph-Hz	220~240-1-50	
Max. Input consumption	W	2950	
Max. Current	A	13.5	
Indoor fan motor	Model	/	ZKFP-46-8-1
	Qty	/	1
	Input	W	45.0
	Capacitor	μF	/
	Speed(Hi/Mi/Lo)	r/min	752/664/576
Indoor coil	Number of rows	/	2
	Tube pitch(a)x row pitch(b)	mm	21x13.37
	Fin spacing	mm	1.3
	Fin type (code)	/	Hydrophilic aluminum
	Tube outside dia. and type	mm	φ7,Inner groove tube
	Coil length x height x width	mm	1360x210x26.74
	Number of circuits	/	4
Indoor air flow	m ³ /h	720/625/540	
Indoor sound pressure level	dB(A)	42.5/39/35.5	
Indoor sound power level	dB(A)	56	
Indoor unit	Dimension (W x Dx H)(body)	mm	570x570x260
	Packing (W x Dx H)(body)	mm	662x662x317
	Dimension (W x Dx H)(panel)	mm	647x647x50
	Packing (W x Dx H)(panel)	mm	715x715x123
	Net/Gross weight(body)	kg	16.2/21.4
	Net/Gross weight(panel)	kg	2.5/4.5
Drainage water pipe dia	mm	ODφ25mm	
Refrigerant piping	Liquid side/ Gas side	mm	φ6.35/φ12.7(1/4"/1/2")
Controller	Standard	Remote control	
Operation temperature	C	17-30	
Room temperature	Cooling	C	17~32
	Heating	C	0~30
Qty'per 20' /40' /40'HQ	Indoor unit	186/375/429	
Compressor	Model	/	KSN140D21UFZ
	Type	/	ROTARY
	Brand	/	GMCC
	Capacity	W	4385
	Input	W	1140
	Rated current	A	7.50
	Refrigerant oil/oil charge	mL	VG74 440
Outdoor Fan motor	Model	/	ZKFN-34-8-1-3
	Qty	/	1
	Input	W	58
	Capacitor	μF	/
	Speed(Hi)	r/min	850/800/750/700

Condenser	Number of rows	/	2
	Tube pitch(a)x row pitch(b)	mm	21x22
	Fin spacing	mm	1.3
	Fin type (code)	/	Hydrophilic aluminum
	Tube outside dia. and type	mm	Φ7,Inner groove tube
	Coil length x height x width	mm	860x504x44
	Number of circuits	/	2
Outdoor side air flow(Hi)		m ³ /h	2000
Outdoor sound pressure level		dB(A)	55.5
Outdoor sound power level		dB(A)	63
Throttle type	Throttle type	/	EXV
Outdoor unit	Dimension(WxDxH)	mm	800x333x554
	Packing(WxDxH)	mm	920x390x615
	Net/Gross weight	kg	33.7/36.6
Refrigerant	Refrigerant type	/	R32
	GWP	/	675
	Refrigerant charge	kg	1.15
Design pressure		MPa	4.3/1.7
Refrigerant piping	Liquid side/ Gas side	mm(inch)	Φ6.35/Φ12.7(1/4"/1/2")
	Max. pipe length	m	30
	Max. difference in level	m	20
Ambient temperature	Cooling	C	-15~50
	Heating	C	-15~24
Qty'per 20' /40' /40'HQ		Outdoor unit	108/219/292

Notes:

1) Capacities are based on the following conditions:

Cooling(T1): - Indoor Temperature 27°C(80.6°F) DB /19 °C(66.2°F) WB Heating: - Indoor Temperature 20°C(68°F) DB / 15°C(59°F) WB
 -Outdoor Temperature 35 °C(95°F) DB /24 °C(75.2°F) WB -Outdoor Temperature 7°C(44.6°F) DB / 6°C(42.8°F) WB
 -Interconnecting Piping Length 5m - Interconnecting Piping Length 5 m
 - Level Difference of Zero. - Level Difference of Zero.

2) Capacities are Net Capacities.

3) Due to our policy of innovation some specifications may be changed without notification.

3. Dimensional Drawings

Indoor Unit

Cassette 650x650 BOX-SL 2

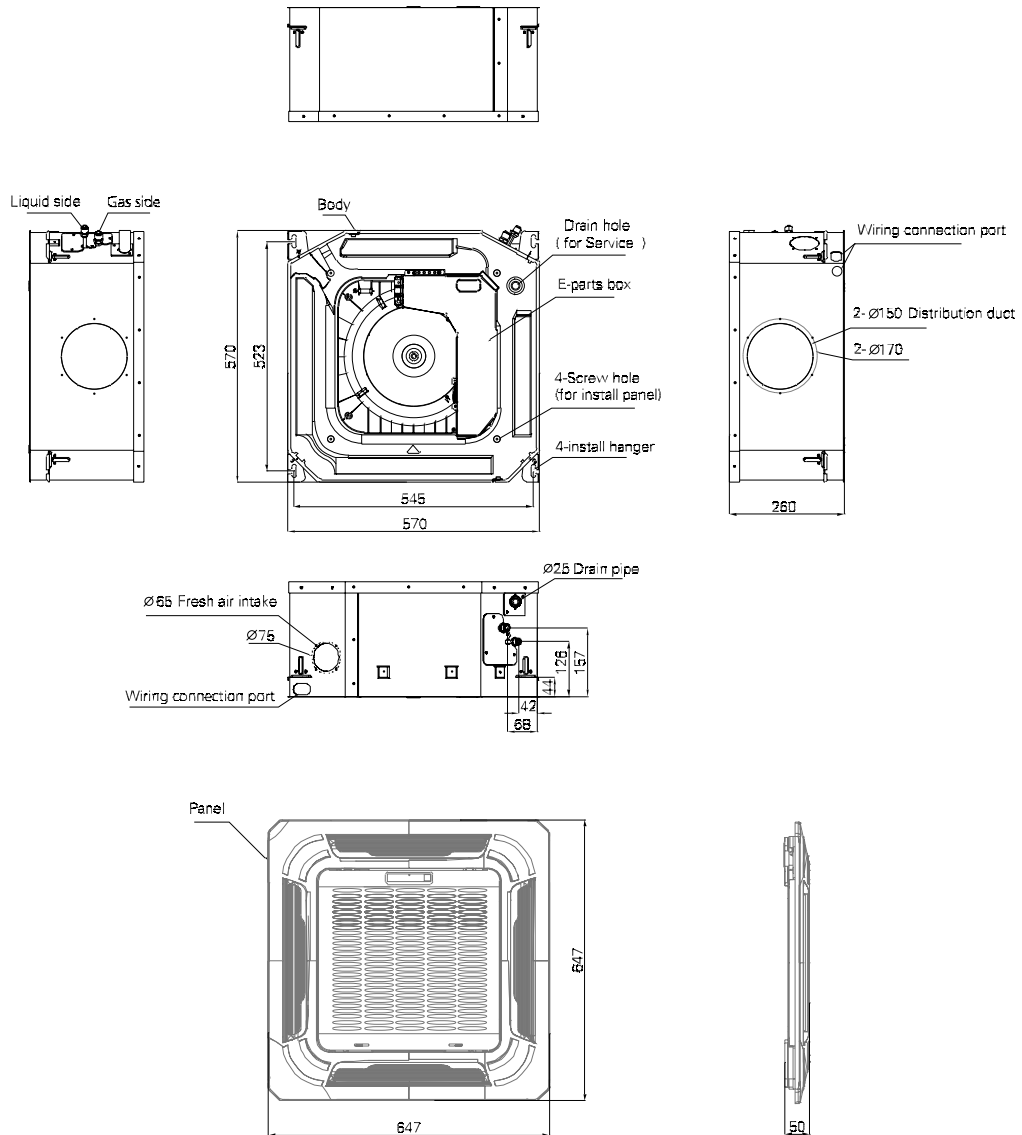

Specifications

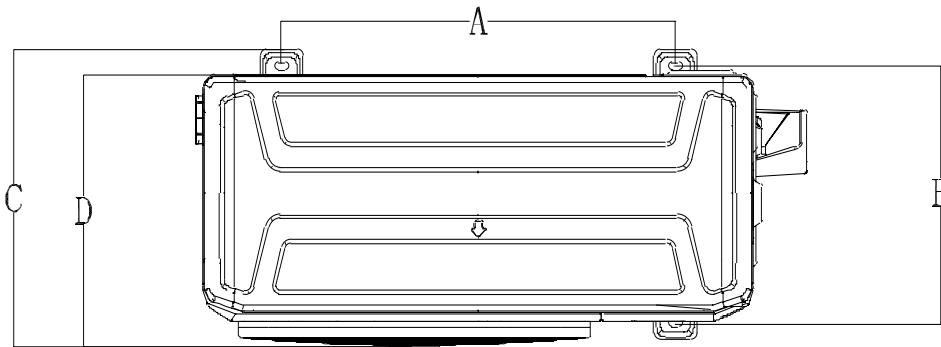
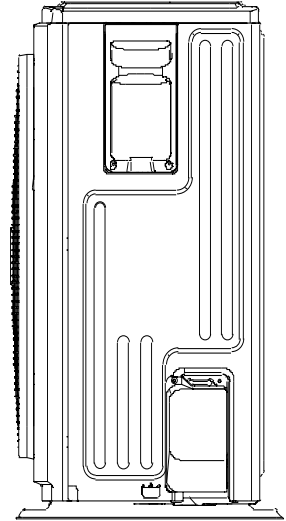
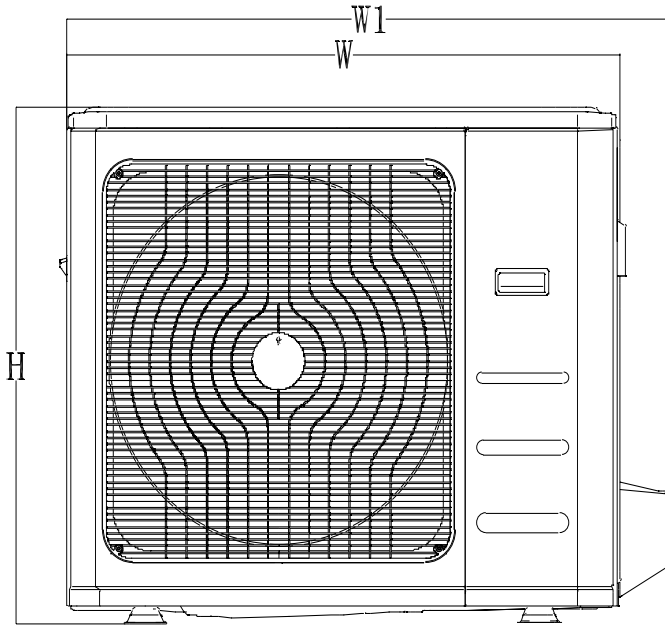

Model	Unit	W	D	H	W1	A	B	C
MC2-Y 53M	mm	800	333	554	870	514	340	365
	inch	31.49	13.11	21.81	34.25	20.23	13.39	14.37

4. Centre of gravity

MC2-Y 53M

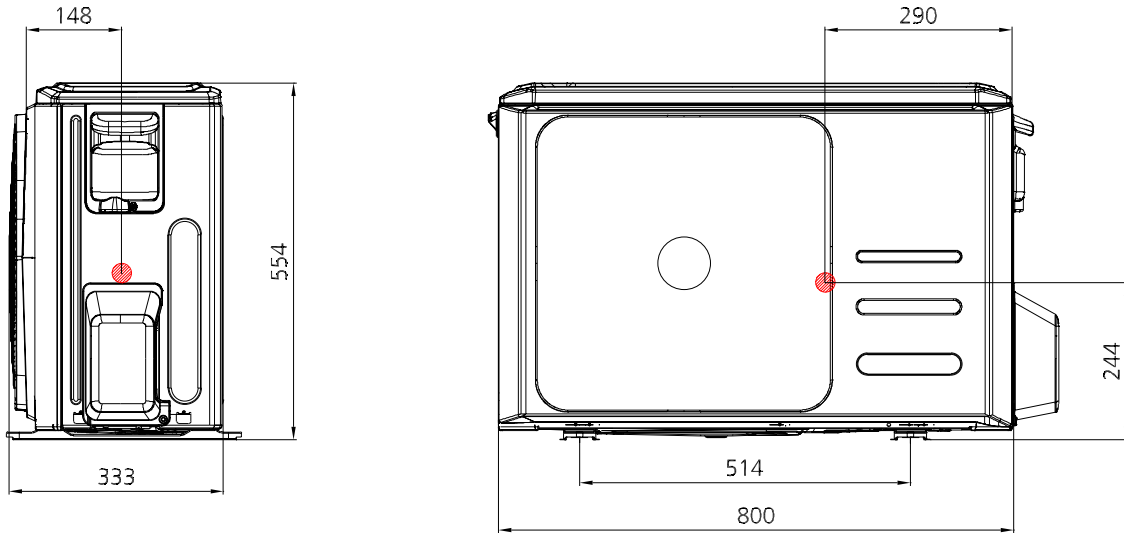

5. Electrical Wiring Diagrams

5.1 Indoor unit

Abbreviation	Paraphrase
Y/G	Yellow-Green Conductor
CAP1	Indoor Fan Capacitor
FAN1	Indoor Fan
L	LIVE
N	NEUTRAL
TO CCM Comm.Bus	Central Controller
T1	Indoor Room Temperature
T2	Coil Temperature of Indoor Heat Exchanger
P3	Super High Speed
P2	High Speed

IB2-XY 53M

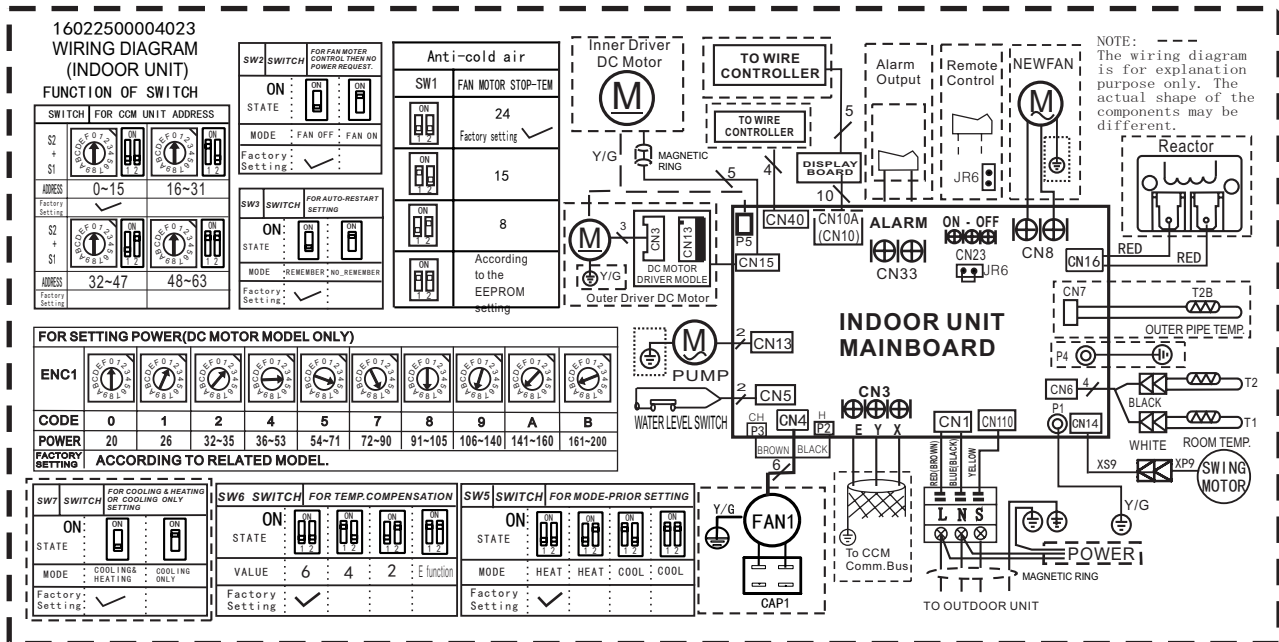

Specifications

5.2 Some connectors introduce:

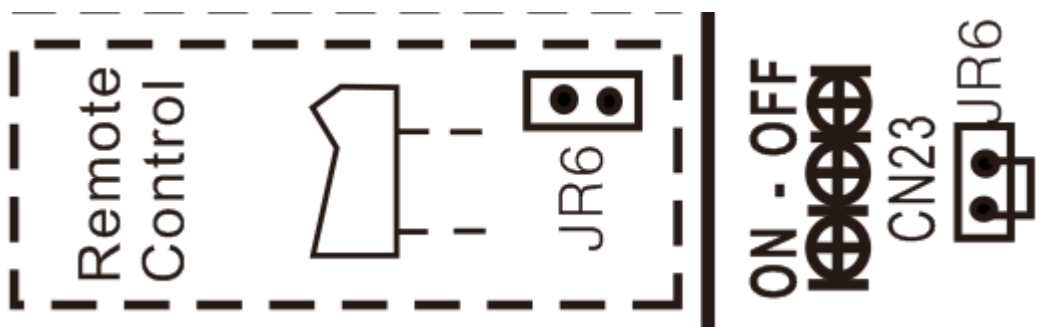

- A For remote control (ON-OFF) terminal port CN23 and short connector of JR6
1. Remove the short connector of JR6 when you use ON-OFF function;
 2. When remote switch off (OPEN) ;the unit would be off;
 3. When remote switch on (CLOSE) ;the unit would be on;
 4. When close/open the remote switch, the unit would be responded the demand within 2 seconds;
 5. When the remote switch on. you can use remote controller/ wire controller to select the mode what you want ;when the remote switch off , the unit would not respond the demand from remote controller/wire controller. when the remote switch off , but the remote controller / wire controller are on, CP code would be shown on the display board.
 6. The voltage of the port is 12V DC , design Max.current is 5mA.

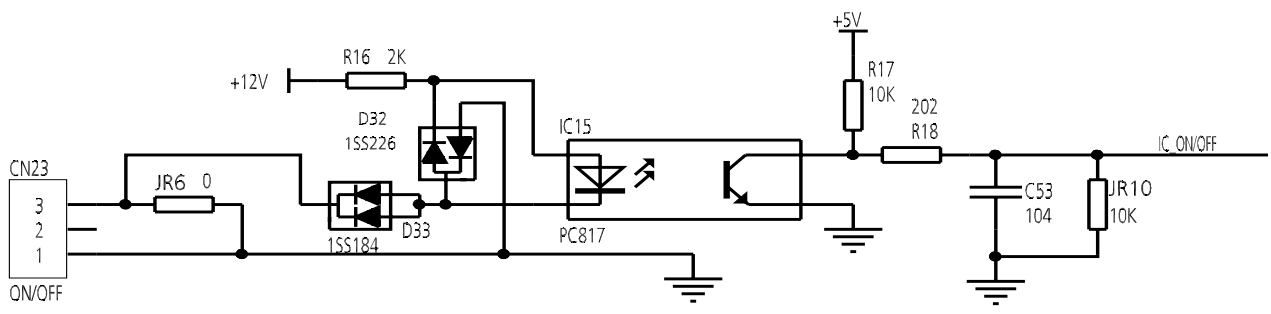



B For ALARM terminal port CN33

1. Provide the terminal port to connect ALARM ,but no voltage of the terminal port , the power from the ALARM system (not from the unit)
2. Although design voltage can support higher voltage ,but we strongly ask you connect the power less than 24V, current less than 0.5A
3. When the unit occurs the problem , the relay would be closed , then ALARM works

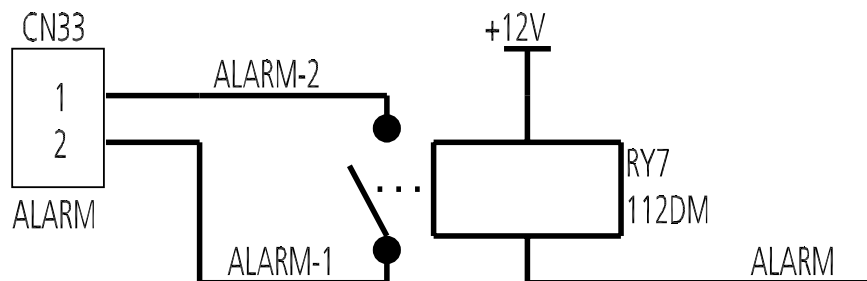

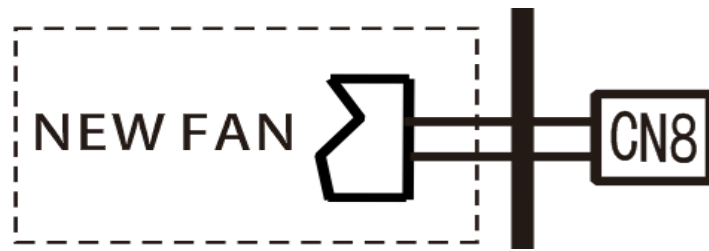

C. For new fresh motor terminal port CN8

1. Connect the fan motor to the port , no need care L/N of the motor ;
2. The output voltage is the power supply;
3. The fresh motor can not excess 200W or 1A , follow the smaller one ;
4. The new fresh motor will be worked when the indoor fan motor work ;when the indoor fan motor stops , the new fresh motor would be stopped ;
5. When the unit enter force cooling mode or capacity testing mode , the fresh motor isn't work .

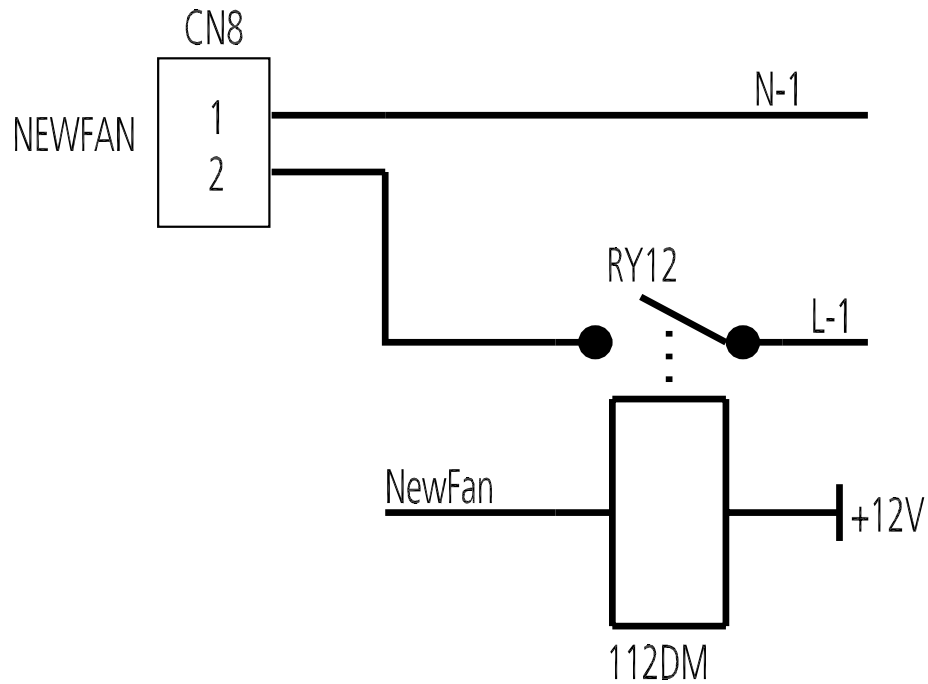

5.3 Micro-Switch introduce:

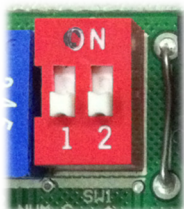

Anti-cold air	
SW1	FAN MOTOR STOP-TEM
	24 Factory setting ✓
	15
	8
	According to the EEPROM setting

A. Micro-switch SW1 is for selection of indoor fan stop temperature (TELO) when it is in anti-cold wind action in heating mode.

Range: 24°C, 15°C, 8°C, According to EEROM setting (reserved for special customizing).

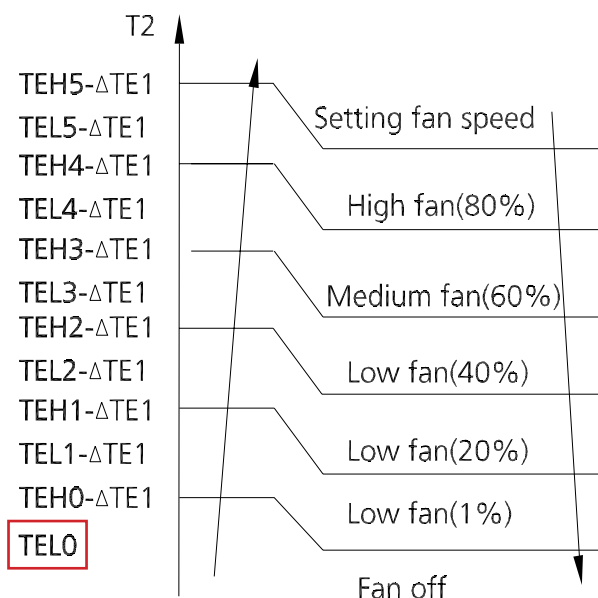

SW2	SWITCH	FOR FAN MOTER CONTROL THEN NO POWER REQUEST.	
ON:			
STATE
MODE	FAN OFF	FAN ON	
Factory Setting	✓		

B. Micro-switch SW2 is for selection of indoor FAN ACTION if room temperature reaches the setpoint and the compressor stops.

Range: OFF (anti-cold wind is available in heating mode), Keep running (No anti-cold wind function).

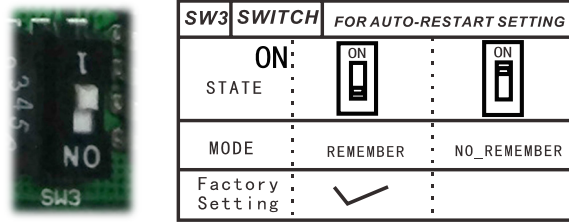

C. Micro-switch SW3 is for selection of auto-restart function.
Range: Active, inactive

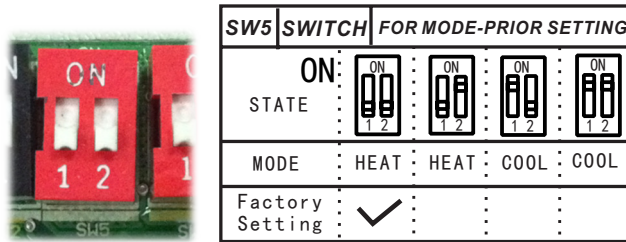

D. Micro-switch SW5 is for setting mode priority of multi connection.
Range: Heat, cool.

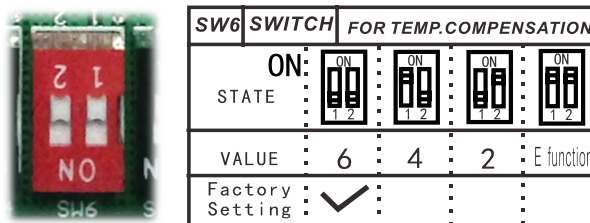

E. Micro-switch SW6 is for selection of temperature compensation in heating mode. This helps to reduce the real temperature difference between ceiling and floor so that the unit could run properly. If the height of installation is lower, smaller value could be chosen.
Range: 6°C, 4°C, 2°C, E function (reserved for special customizing)

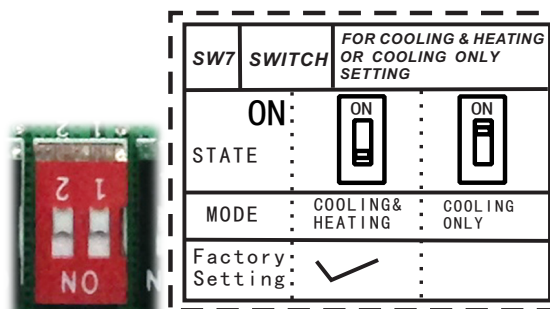

F. Micro-switch SW7 is for setting cooling & heating or cooling only.
Range: cooling & heating, cooling.

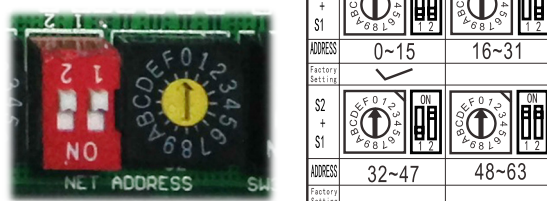

G. Micro-switch S1 and dial-switch S2 are for address setting when you want to control this unit by a central controller.
Range: 00-63



FOR SETTING POWER(DC MOTOR MODEL ONLY)										
ENC1										
CODE	0	1	2	4	5	7	8	9	A	B
POWER	20	26	32-35	36-53	54-71	72-90	91-105	106-140	141-160	161-200
FACTORY SETTING	ACCORDING TO RELATED MODEL.									

H. Dial-switch ENC1: The indoor PCB is universal designed for whole series units from 7K to 68K. This ENC1 setting will tell the main program what size the unit is.

NOTE: Usually there is glue on it because the switch position cannot be changed at random unless you want to use this PCB as a spare part to use in another unit. Then you have to select the right position to match the size of the unit.

“20” means 2kW (7K), “105” means 10.5kW(36K), and so on.

5.4 Outdoor Unit

Abbreviation	Paraphrase
CAP1, CAP2, CAP3,CAP4	Fan Motor Capacitor
FM1,FM2	Outdoor DC Fan
FAN1, FAN2	Outdoor AC Fan
HEAT, HEAT_Y,HEAT_D	CRANKCASE HEATING
CT1, CT2	AC Current Detector
COMP	Compressor
L-PRO	Low Pressure Switch
H-PRO	High Pressure Switch
L	PFC Inductor
SV	4-Way Valve
TRANS	Power Transformer
TP	Exhaust Temperature Sensor
T4	Outdoor Ambient Temperature Sensor
T3	Condenser Temperature Sensor
TH	Heatsink Temperature Sensor
XT1	2-Way Terminal/4-Way Terminal
XT2	3-Way Terminal
XT4	Terminal
EEV	Electronic Expansion Valve
D	Diode Module

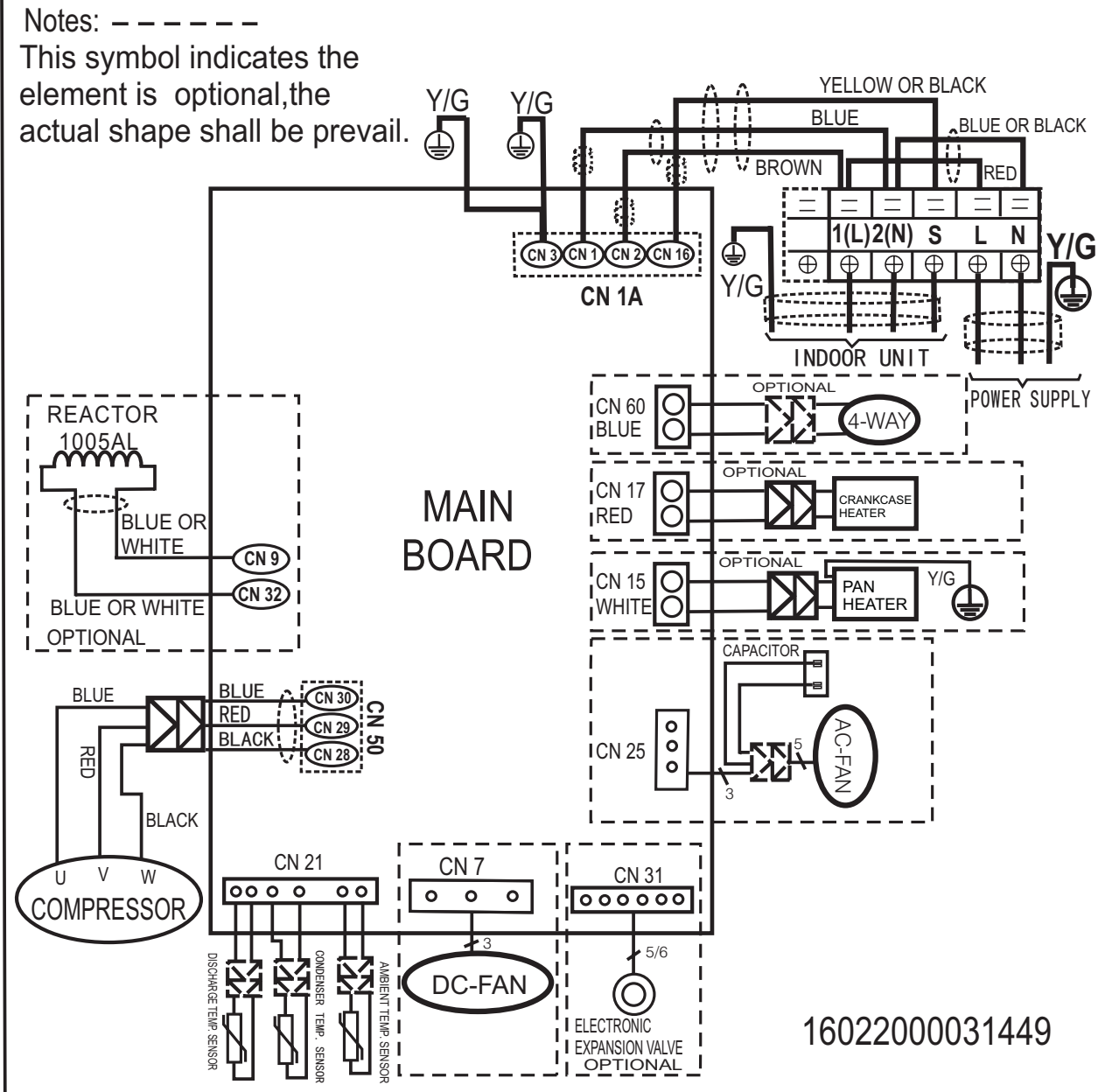

6. Refrigerant Cycle Diagrams

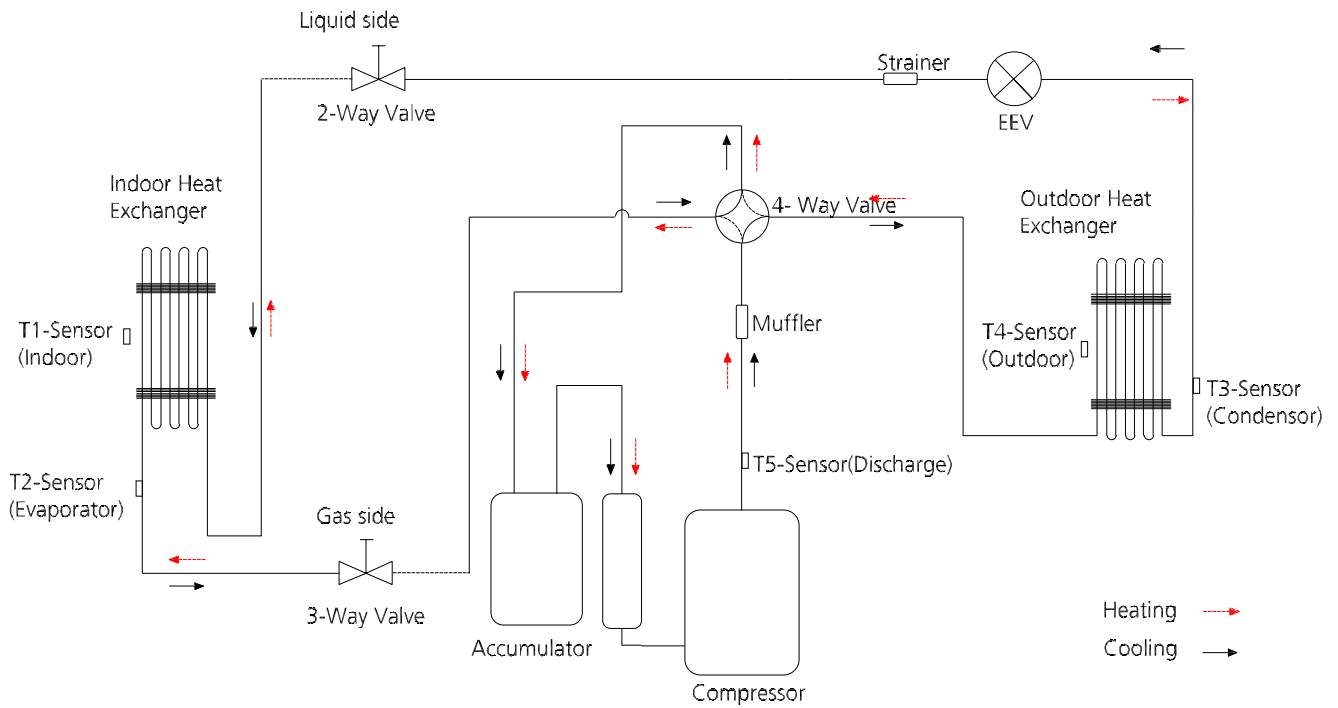

Model No.	Pipe Size (Diameter:ø) mm(inch)		Piping length (m/ft)		Elevation (m/ft)		Additional Refrigerant
	Gas	Liquid	Rated	Max.	Rated	Max.	
MC2-Y 53M	12.7(1/2)	6.35(1/4)	5/16.4	30/98.4	0	20/65.6	12g/m (0.13oz/ft)

7. Capacity Tables

Cooling

		IB2-XY 53M+ MC2-Y 53M																
INDOOR AIRFLOW (CMH)	OUTDOOR DB (°C)	ID WB (°C)	16.0				18.0				19.0				22.0			
		ID DB (°C)	23.0	25.0	27.0	29.0	23.0	25.0	27.0	29.0	23.0	25.0	27.0	29.0	23.0	25.0	27.0	29.0
540	-15	TC	5.50	5.50	5.50	5.56	5.78	5.90	5.90	5.90	5.93	5.93	5.93	5.93	6.28	6.28	6.28	6.28
		S/T	0.67	0.73	0.80	0.86	0.55	0.61	0.68	0.73	0.49	0.56	0.62	0.68	0.37	0.42	0.48	0.54
		PI	1.09	1.08	1.08	1.09	1.08	1.08	1.08	1.08	1.09	1.09	1.09	1.09	1.08	1.08	1.08	1.08
	-10	TC	5.46	5.47	5.47	5.53	5.75	5.87	5.87	5.87	5.90	5.90	5.90	5.90	6.25	6.25	6.25	6.25
		S/T	0.67	0.74	0.81	0.86	0.55	0.62	0.68	0.74	0.49	0.56	0.62	0.68	0.37	0.43	0.49	0.54
		PI	1.08	1.08	1.08	1.08	1.08	1.08	1.08	1.08	1.08	1.08	1.08	1.08	1.08	1.08	1.08	1.08
	-5	TC	5.43	5.43	5.43	5.49	5.73	5.85	5.85	5.85	5.88	5.88	5.88	5.88	6.24	6.24	6.24	6.24
		S/T	0.67	0.74	0.81	0.87	0.56	0.62	0.68	0.74	0.50	0.57	0.62	0.68	0.37	0.43	0.49	0.55
		PI	1.08	1.08	1.08	1.08	1.08	1.08	1.08	1.08	1.08	1.08	1.08	1.08	1.08	1.08	1.08	1.08
	0	TC	5.40	5.41	5.41	5.47	5.71	5.83	5.83	5.83	5.87	5.87	5.87	5.87	6.23	6.23	6.23	6.23
		S/T	0.68	0.74	0.81	0.87	0.56	0.62	0.69	0.74	0.50	0.57	0.63	0.69	0.37	0.43	0.49	0.55
		PI	1.08	1.08	1.08	1.08	1.08	1.08	1.08	1.08	1.09	1.09	1.09	1.09	1.09	1.09	1.09	1.09
	5	TC	5.38	5.38	5.38	5.44	5.68	5.80	5.80	5.80	5.85	5.85	5.85	5.85	6.23	6.23	6.23	6.23
		S/T	0.68	0.75	0.82	0.88	0.56	0.62	0.69	0.75	0.50	0.57	0.63	0.69	0.37	0.43	0.49	0.55
		PI	1.09	1.09	1.09	1.09	1.09	1.09	1.09	1.09	1.10	1.10	1.10	1.10	1.09	1.09	1.09	1.09
	10	TC	5.34	5.35	5.35	5.41	5.66	5.78	5.78	5.78	5.82	5.82	5.82	5.82	6.21	6.21	6.21	6.21
		S/T	0.68	0.75	0.82	0.88	0.56	0.63	0.69	0.75	0.50	0.57	0.63	0.69	0.38	0.44	0.50	0.55
		PI	1.11	1.11	1.11	1.11	1.11	1.11	1.11	1.11	1.11	1.11	1.11	1.11	1.11	1.11	1.11	1.11
	15	TC	5.30	5.30	5.30	5.36	5.62	5.74	5.74	5.74	5.79	5.79	5.79	5.79	6.19	6.19	6.19	6.19
		S/T	0.69	0.76	0.83	0.89	0.57	0.63	0.70	0.76	0.51	0.58	0.64	0.70	0.38	0.44	0.50	0.56
		PI	1.14	1.14	1.14	1.14	1.14	1.14	1.14	1.14	1.14	1.14	1.14	1.14	1.13	1.13	1.13	1.13
	20	TC	5.24	5.24	5.24	5.30	5.56	5.56	5.56	5.56	5.73	5.73	5.73	5.73	6.13	6.13	6.13	6.13
		S/T	0.69	0.76	0.83	0.89	0.57	0.63	0.70	0.76	0.51	0.58	0.64	0.70	0.38	0.44	0.50	0.56
		PI	1.18	1.18	1.18	1.18	1.18	1.18	1.18	1.18	1.18	1.18	1.18	1.18	1.17	1.17	1.17	1.17
	25	TC	4.99	4.99	4.99	5.04	5.30	5.30	5.30	5.30	5.47	5.47	5.47	5.47	5.87	5.87	5.87	5.87
		S/T	0.69	0.77	0.84	0.91	0.57	0.64	0.71	0.77	0.51	0.58	0.64	0.71	0.38	0.44	0.50	0.56
		PI	1.30	1.30	1.30	1.30	1.30	1.30	1.30	1.30	1.30	1.30	1.30	1.30	1.30	1.30	1.30	1.30
	30	TC	4.76	4.76	4.76	4.81	5.07	5.07	5.07	5.07	5.22	5.22	5.22	5.22	5.62	5.62	5.62	5.62
		S/T	0.70	0.78	0.85	0.92	0.57	0.64	0.71	0.79	0.51	0.58	0.65	0.72	0.37	0.44	0.50	0.57
		PI	1.42	1.42	1.42	1.42	1.43	1.43	1.43	1.43	1.43	1.43	1.43	1.43	1.43	1.43	1.43	1.43
	35	TC	4.53	4.53	4.53	4.59	4.81	4.81	4.81	4.81	4.96	4.96	4.96	4.96	5.36	5.36	5.36	5.36
		S/T	0.71	0.79	0.87	0.94	0.57	0.65	0.72	0.80	0.51	0.59	0.66	0.73	0.37	0.44	0.50	0.57
		PI	1.56	1.56	1.56	1.56	1.56	1.56	1.56	1.56	1.57	1.57	1.57	1.57	1.58	1.58	1.58	1.58
	40	TC	4.28	4.28	4.29	4.34	4.55	4.55	4.55	4.55	4.70	4.70	4.74	4.70	5.07	5.07	5.07	5.07
		S/T	0.72	0.81	0.89	0.98	0.58	0.66	0.75	0.83	0.51	0.59	0.67	0.75	0.36	0.44	0.51	0.58
		PI	1.72	1.72	1.72	1.72	1.72	1.72	1.72	1.72	1.73	1.73	1.73	1.73	1.74	1.74	1.74	1.74
	46	TC	3.97	3.97	4.00	4.02	4.22	4.22	4.22	4.22	4.37	4.37	4.37	4.37	4.71	4.71	4.71	4.71
		S/T	0.73	0.82	0.91	1.00	0.58	0.67	0.76	0.84	0.52	0.60	0.68	0.76	0.36	0.44	0.51	0.59
		PI	1.91	1.91	1.91	1.91	1.92	1.92	1.92	1.92	1.92	1.92	1.92	1.92	1.94	1.94	1.94	1.94
	50	TC	3.71	3.71	3.74	3.77	3.97	3.97	3.97	3.97	4.11	4.11	4.11	4.11	4.45	4.45	4.45	4.45
		S/T	0.74	0.84	0.94	1.00	0.59	0.68	0.77	0.86	0.52	0.61	0.69	0.78	0.36	0.44	0.52	0.60
		PI	2.07	2.07	2.07	2.07	2.08	2.08	2.08	2.08	2.09	2.09	2.09	2.09	2.10	2.10	2.10	2.10

Specifications

625	-15	TC	5.62	5.62	5.62	5.68	5.90	5.90	5.90	5.90	6.06	6.06	6.06	6.06	6.43	6.43	6.43	6.43
		S/T	0.68	0.75	0.98	1.00	0.55	0.63	0.70	0.76	0.49	0.56	0.63	0.70	0.36	0.42	0.48	0.55
		PI	1.11	1.11	1.11	1.11	1.10	1.10	1.10	1.10	1.10	1.10	1.10	1.10	1.10	1.10	1.10	1.10
	-10	TC	5.59	5.59	5.59	5.65	5.87	5.87	5.87	5.87	6.03	6.03	6.03	6.03	6.40	6.40	6.40	6.40
		S/T	0.68	0.76	0.99	1.00	0.55	0.63	0.70	0.77	0.49	0.56	0.63	0.71	0.36	0.43	0.49	0.55
		PI	1.10	1.10	1.10	1.10	1.10	1.10	1.10	1.10	1.10	1.10	1.10	1.10	1.11	1.11	1.11	1.11
	-5	TC	5.56	5.56	5.56	5.62	5.85	5.85	5.85	5.85	6.00	6.00	6.00	6.00	6.39	6.39	6.39	6.39
		S/T	0.68	0.76	0.99	1.00	0.56	0.63	0.70	0.77	0.50	0.57	0.63	0.71	0.36	0.43	0.49	0.56
		PI	1.10	1.10	1.10	1.10	1.10	1.10	1.10	1.10	1.10	1.10	1.10	1.10	1.11	1.11	1.11	1.11
	0	TC	5.53	5.53	5.53	5.59	5.83	5.83	5.83	5.83	5.99	5.99	5.99	5.99	6.38	6.38	6.38	6.38
		S/T	0.69	0.76	1.00	1.00	0.56	0.64	0.71	0.77	0.50	0.57	0.64	0.72	0.36	0.43	0.49	0.56
		PI	1.11	1.11	1.11	1.11	1.10	1.10	1.10	1.10	1.10	1.10	1.10	1.10	1.11	1.11	1.11	1.11
	5	TC	5.50	5.50	5.50	5.56	5.80	5.80	5.80	5.80	5.97	5.97	5.97	5.97	6.38	6.38	6.38	6.38
		S/T	0.69	0.77	1.00	1.00	0.56	0.64	0.71	0.78	0.50	0.57	0.64	0.72	0.36	0.43	0.49	0.56
		PI	1.12	1.12	1.12	1.12	1.11	1.11	1.11	1.11	1.11	1.11	1.11	1.11	1.12	1.12	1.12	1.12
	10	TC	5.47	5.47	5.47	5.53	5.78	5.78	5.78	5.78	5.94	5.94	5.94	5.94	6.36	6.36	6.36	6.36
		S/T	0.69	0.77	1.00	1.00	0.56	0.64	0.71	0.78	0.50	0.57	0.64	0.72	0.37	0.44	0.50	0.56
		PI	1.13	1.13	1.13	1.13	1.13	1.13	1.13	1.13	1.13	1.13	1.13	1.13	1.13	1.13	1.13	1.13
15	TC	5.42	5.42	5.42	5.48	5.74	5.74	5.74	5.74	5.91	5.91	5.91	5.91	6.33	6.33	6.33	6.33	
	S/T	0.70	0.78	0.86	0.93	0.57	0.65	0.72	0.79	0.51	0.58	0.65	0.73	0.37	0.44	0.50	0.57	
	PI	1.16	1.16	1.16	1.16	1.15	1.15	1.15	1.15	1.15	1.15	1.15	1.15	1.16	1.16	1.16	1.16	
20	TC	5.36	5.36	5.36	5.42	5.68	5.68	5.68	5.68	5.85	5.85	5.85	5.85	6.28	6.28	6.28	6.28	
	S/T	0.70	0.78	0.86	0.93	0.57	0.65	0.72	0.79	0.51	0.58	0.65	0.73	0.37	0.44	0.50	0.57	
	PI	1.20	1.20	1.20	1.20	1.19	1.19	1.19	1.19	1.19	1.19	1.19	1.19	1.19	1.19	1.19	1.19	
25	TC	5.10	5.10	5.10	5.16	5.42	5.42	5.42	5.42	5.59	5.59	5.59	5.59	6.02	6.02	6.02	6.02	
	S/T	0.71	0.79	0.87	0.95	0.58	0.65	0.73	0.81	0.51	0.59	0.66	0.74	0.37	0.44	0.51	0.58	
	PI	1.32	1.32	1.32	1.32	1.32	1.32	1.32	1.32	1.32	1.32	1.32	1.32	1.32	1.32	1.32	1.32	
30	TC	4.87	4.87	4.93	4.99	5.19	5.19	5.19	5.19	5.33	5.33	5.33	5.33	5.76	5.76	5.76	5.76	
	S/T	0.72	0.80	0.89	0.97	0.58	0.66	0.74	0.82	0.51	0.59	0.67	0.75	0.36	0.44	0.51	0.58	
	PI	1.45	1.45	1.45	1.45	1.46	1.46	1.46	1.46	1.46	1.46	1.46	1.46	1.46	1.46	1.46	1.46	
35	TC	4.62	4.62	4.67	4.73	4.93	4.93	4.93	4.93	5.07	5.07	5.16	5.07	5.48	5.48	5.48	5.48	
	S/T	0.73	0.82	0.91	0.99	0.58	0.67	0.75	0.84	0.52	0.60	0.68	0.76	0.36	0.44	0.51	0.59	
	PI	1.58	1.58	1.58	1.58	1.59	1.59	1.59	1.59	1.59	1.59	1.60	1.59	1.59	1.59	1.59	1.59	
40	TC	4.34	4.34	4.38	4.43	4.63	4.63	4.63	4.65	4.77	4.77	4.82	4.77	5.16	5.16	5.16	5.16	
	S/T	0.75	0.85	0.94	1.00	0.59	0.68	0.78	0.87	0.52	0.61	0.70	0.79	0.35	0.44	0.52	0.60	
	PI	1.74	1.74	1.74	1.74	1.75	1.75	1.75	1.75	1.75	1.75	1.76	1.75	1.76	1.76	1.76	1.76	
46	TC	4.03	4.03	4.06	4.09	4.29	4.29	4.29	4.34	4.43	4.43	4.43	4.43	4.80	4.80	4.80	4.80	
	S/T	0.76	0.86	0.96	1.00	0.60	0.69	0.79	0.88	0.52	0.62	0.71	0.80	0.35	0.44	0.52	0.61	
	PI	1.94	1.94	1.94	1.94	1.95	1.95	1.95	1.95	1.95	1.95	1.95	1.95	1.97	1.97	1.97	1.97	
50	TC	3.77	3.80	3.83	3.86	4.03	4.03	4.03	4.06	4.17	4.17	4.17	4.17	4.51	4.51	4.51	4.51	
	S/T	0.78	0.88	0.99	1.00	0.60	0.71	0.81	0.91	0.53	0.63	0.73	0.83	0.35	0.44	0.53	0.91	
	PI	2.11	2.11	2.11	2.11	2.11	2.11	2.11	2.11	2.12	2.12	2.12	2.12	2.14	2.14	2.14	2.14	
720	-15	TC	5.74	5.74	5.80	5.86	6.05	6.05	6.05	6.05	6.20	6.20	6.20	6.20	6.57	6.57	6.57	6.57
		S/T	0.70	0.78	1.00	1.00	0.56	0.64	0.72	0.98	0.49	0.57	0.66	0.73	0.35	0.42	0.49	0.57
		PI	1.14	1.14	1.14	1.14	1.13	1.13	1.13	1.13	1.13	1.13	1.13	1.13	1.12	1.12	1.12	1.12
	-10	TC	5.71	5.71	5.77	5.83	6.02	6.02	6.02	6.02	6.17	6.17	6.17	6.17	6.55	6.55	6.55	6.55
		S/T	0.70	0.79	1.00	1.00	0.56	0.64	0.73	0.98	0.49	0.57	0.66	0.74	0.35	0.43	0.49	0.57
		PI	1.13	1.13	1.13	1.13	1.12	1.12	1.12	1.12	1.13	1.13	1.13	1.13	1.12	1.12	1.12	1.12
	-5	TC	5.67	5.67	5.73	5.79	6.00	6.00	6.00	6.00	6.15	6.15	6.15	6.15	6.53	6.53	6.53	6.53
		S/T	0.70	0.79	1.00	1.00	0.57	0.64	0.73	0.99	0.50	0.58	0.66	0.74	0.35	0.43	0.50	0.58
		PI	1.13	1.13	1.13	1.13	1.12	1.12	1.12	1.12	1.13	1.13	1.13	1.13	1.13	1.13	1.13	1.13
	0	TC	5.65	5.65	5.71	5.76	5.97	5.97	5.97	5.97	6.13	6.13	6.13	6.13	6.53	6.53	6.53	6.53
		S/T	0.71	0.79	1.00	1.00	0.57	0.65	0.74	0.99	0.50	0.58	0.67	0.74	0.35	0.43	0.50	0.58
		PI	1.13	1.13	1.13	1.13	1.13	1.13	1.13	1.13	1.13	1.13	1.13	1.13	1.13	1.13	1.13	1.13
	5	TC	5.62	5.62	5.68	5.74	5.95	5.95	5.95	5.95	6.11	6.11	6.11	6.11	6.52	6.52	6.52	6.52
		S/T	0.71	0.80	1.00	1.00	0.57	0.65	0.74	1.00	0.50	0.58	0.67	0.75	0.35	0.43	0.50	0.58
		PI	1.14	1.14	1.14	1.14	1.14	1.14	1.14	1.14	1.14	1.14	1.14	1.14	1.14	1.14	1.14	1.14
	10	TC	5.58	5.58	5.64	5.70	5.92	5.92	5.92	5.92	6.09	6.09	6.09	6.09	6.51	6.51	6.51	6.51
		S/T	0.71	0.80	1.00	1.00	0.57	0.65	0.74	1.00	0.50	0.58	0.67	0.75	0.36	0.44	0.50	0.58
		PI	1.16	1.16	1.16	1.16	1.15	1.15	1.15	1.15	1.16	1.16	1.16	1.16	1.15	1.15	1.15	1.15
15	TC	5.54	5.54	5.60	5.65	5.88	5.88	5.88	5.88	6.05	6.05	6.05	6.05	6.48	6.48	6.48	6.48	
	S/T	0.72	0.81	0.90	0.98	0.58	0.66	0.75	0.83	0.51	0.59	0.68	0.76	0.36	0.44	0.51	0.59	
	PI	1.19	1.19	1.19	1.19	1.18	1.18	1.18	1.18	1.18	1.18	1.18	1.18	1.18	1.18	1.18	1.18	
20	TC	5.48	5.48	5.53	5.59	5.82	5.82	5.82	5.82	5.99	5.99	5.99	5.99	6.42	6.42	6.42	6.42	
	S/T	0.72	0.81	0.90	0.98	0.58	0.66	0.75	0.83	0.51	0.59	0.68	0.76	0.36	0.44	0.51	0.59	
	PI	1.23	1.23	1.23	1.23	1.22	1.22	1.22	1.22	1.22	1.22	1.22	1.22	1.21	1.21	1.21	1.21	
25	TC	5.22	5.22	5.28	5.33	5.56	5.56	5.56	5.56	5.73	5.73	5.73	5.73	6.16	6.16	6.16	6.16	
	S/T	0.73	0.83	0.91	1.00	0.58	0.67	0.76	0.84	0.52	0.60	0.68	0.77	0.36	0.44	0.51	0.59	
	PI	1.35	1.35	1.35	1.35	1.35	1.35	1.35	1.35	1.35	1.35	1.35	1.35	1.35	1.35	1.35	1.35	
30	TC	4.99	4.99	5.05	5.10	5.30	5.30	5.30	5.30	5.45	5.45	5.45	5.45	5.88	5.88	5.88	5.88	
	S/T	0.74	0.84	0.93	1.00	0.59	0.68	0.77	0.86	0.52	0.61	0.70	0.78	0.35	0.44	0.52	0.60	
	PI	1.49	1.49	1.49	1.49	1.49	1.49	1.49	1.49	1.49	1.49	1.49	1.49	1.50	1.50	1.50	1.50	
35	TC	4.73	4.73	4.79	4.85	5.05	5.05	5.05	5.05	5.19	5.19	5.28	5.19	5.59	5.59	5.59	5.59	
	S/T	0.75	0.86	0.95	1.00	0.59	0.69	0.79	0.88	0.52	0.61	0.70	0.80	0.35	0.44	0.52	0.61	
	PI	1.62	1.62	1.62	1.62	1.62	1.62	1.62	1.62	1.63	1.63	1.63	1.63	1.64	1.64	1.64	1.64	
40	TC	4.44	4.45	4.50	4.54	4.74	4.74	4.74	4.77	4.89	4.89	4.93	4.89	5.27	5.27	5.27	5.27	
	S/T	0.78	0.89	0.99	1.00	0.61	0.71	0.82	0.92	0.53	0.63	0.73	0.83	0.35	0.44	0.53	0.90	
	PI	1.79	1.79	1.79	1.79	1.7												

Heating

IB2-XY 53M+ MC2-Y 53M								[SI_Unit]	
INDOOR AIRFLOW (CMH)	HEATING PERFORMANCE AT INDOOR DRY BULB TEMPERATURE								
	OUTDOOR DB(°C)	TC:TOTAL CAPACITY IN KILOWATTS (KW)				PI:TOTAL POWER IN KILOWATTS (KW)			
		Indoor Conditions (DB °C)				Indoor Conditions (DB °C)			
		16.0	20.0	22.0	24.0	16.0	20.0	22.0	24.0
540	-15.0	4.07	4.02	4.00	4.00	1.61	1.67	1.64	1.65
	-10.0	4.35	4.29	4.27	4.27	1.72	1.78	1.75	1.76
	-7.0	4.56	4.50	4.47	4.47	1.83	1.89	1.86	1.87
	-5.6	4.59	4.53	4.50	4.50	1.78	1.80	1.81	1.82
	-2.8	4.61	4.56	4.53	4.50	1.70	1.72	1.73	1.73
	0.0	4.59	4.53	4.50	4.47	1.62	1.63	1.64	1.65
	2.8	4.70	4.64	4.61	4.59	1.56	1.57	1.57	1.58
	5.6	4.99	4.93	4.91	4.88	1.49	1.50	1.50	1.50
	7.0	5.31	5.25	5.16	5.13	1.47	1.44	1.48	1.48
	11.1	5.48	5.39	5.36	5.31	1.36	1.36	1.36	1.36
	13.9	5.60	5.51	5.48	5.45	1.29	1.29	1.29	1.28
	16.7	5.74	5.65	5.60	5.57	1.22	1.21	1.21	1.20
18.0	5.80	5.71	5.65	5.63	1.18	1.18	1.17	1.17	
625	-15.0	4.14	4.11	4.09	4.06	1.62	1.68	1.65	1.67
	-10.0	4.42	4.39	4.36	4.34	1.73	1.79	1.76	1.78
	-7.0	4.63	4.60	4.57	4.54	1.84	1.90	1.87	1.89
	-5.6	4.67	4.64	4.61	4.59	1.80	1.82	1.83	1.84
	-2.8	4.70	4.64	4.64	4.61	1.72	1.73	1.74	1.75
	0.0	4.67	4.61	4.59	4.56	1.64	1.65	1.65	1.66
	2.8	4.82	4.76	4.73	4.70	1.57	1.58	1.58	1.59
	5.6	5.11	5.05	5.02	4.99	1.50	1.51	1.51	1.51
	7.0	5.43	5.36	5.28	5.25	1.48	1.45	1.49	1.49
	11.1	5.60	5.51	5.48	5.45	1.37	1.37	1.37	1.37
	13.9	5.71	5.65	5.60	5.57	1.30	1.30	1.29	1.29
	16.7	5.86	5.77	5.74	5.68	1.23	1.22	1.21	1.21
18.0	5.91	5.83	5.80	5.74	1.19	1.18	1.18	1.17	
720	-15.0	4.20	4.15	4.13	4.13	1.64	1.70	1.67	1.68
	-10.0	4.49	4.43	4.41	4.41	1.75	1.81	1.79	1.80
	-7.0	4.70	4.64	4.62	4.62	1.86	1.93	1.90	1.91
	-5.6	4.73	4.67	4.64	4.64	1.82	1.84	1.85	1.86
	-2.8	4.76	4.70	4.67	4.64	1.73	1.75	1.76	1.77
	0.0	4.73	4.67	4.64	4.61	1.65	1.66	1.67	1.68
	2.8	4.88	4.82	4.76	4.73	1.58	1.59	1.60	1.60
	5.6	5.17	5.11	5.08	5.02	1.52	1.52	1.52	1.53
	7.0	5.48	5.42	5.34	5.31	1.49	1.46	1.50	1.50
	11.1	5.65	5.57	5.54	5.51	1.38	1.38	1.38	1.38
	13.9	5.80	5.71	5.65	5.63	1.31	1.30	1.30	1.30
	16.7	5.91	5.83	5.80	5.74	1.23	1.22	1.22	1.21
18.0	6.00	5.91	5.86	5.80	1.19	1.18	1.18	1.17	

Note: The table shows the case where the operation frequency of a compressor is fixed.

8. Capacity Correction Factor for Height Difference

Model	53M		Pipe Length (m)			
Cooling			5	10	20	30
Height difference H (m)	Indoor Upper than Outdoor	20			0.928	0.912
		10		0.969	0.937	0.921
		5	0.995	0.979	0.946	0.930
		0	1.000	0.984	0.951	0.935
	Outdoor Upper than Indoor	-5	1.000	0.984	0.951	0.935
		-10		0.984	0.951	0.935
		-20			0.951	0.935
Heating			5	10	20	30
Height difference H (m)	Indoor Upper than Outdoor	20			0.982	0.976
		10		0.994	0.982	0.976
		5	1.000	0.994	0.982	0.976
		0	1.000	0.994	0.982	0.976
	Outdoor Upper than Indoor	-5	0.992	0.986	0.974	0.968
		-10		0.978	0.966	0.960
		-20			0.959	0.953

9. Noise Criterion Curves

Indoor Unit

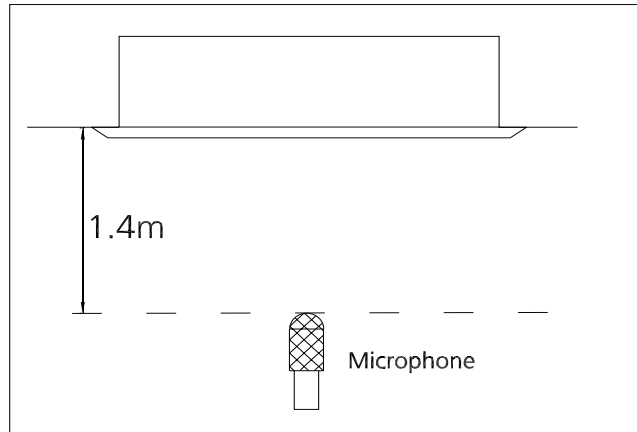

Notes:

- Sound measured at 1.4m away from the noisiest location of the unit.
- Data is valid at free field condition
- Data is valid at nominal operation condition
- Reference acoustic pressure $OdB = 20\mu Pa$
- Sound level will vary depending on a range of factors such as the construction -(acoustic absorption coefficient) of particular room in which the equipment is installed.
- The operating conditions are assumed to be standard.

IB2-XY 53M

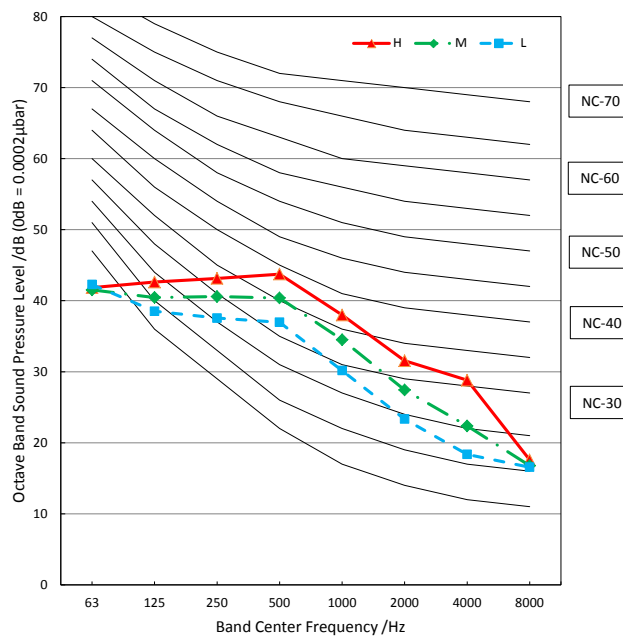

Outdoor Unit

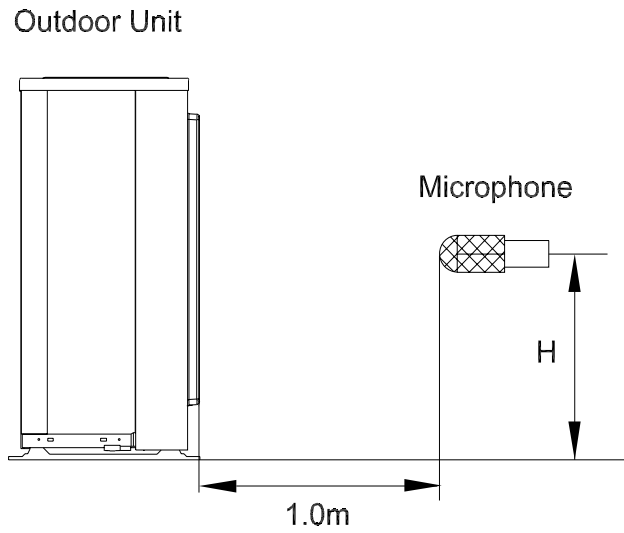

Note: $H = 0.5 \times$ height of outdoor unit

Notes:

- Sound measured at 1.0m away from the center of the unit.
- Data is valid at free field condition
- Data is valid at nominal operation condition
- Reference acoustic pressure $OdB = 20\mu Pa$
- Sound level will vary depending on arrange off actors such as the construction (acoustic absorption coefficient) of particular room in which the equipment is installed.
- The operating conditions are assumed to be standard.

MC2-Y 53M

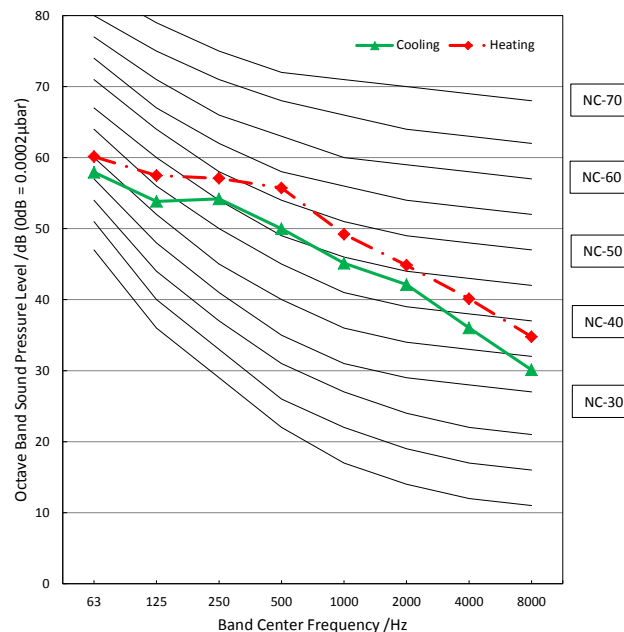

10. Electrical Characteristics

Type	53M	
Phase	1-phase	
Frequency and Voltage	220-240V, 50Hz	
Circuit Breaker/ Fuse (A)	25/20	
Indoor Unit Power Wiring (mm ²)		
Outdoor Unit Power Wiring (mm ²)	3×2.5	
Indoor/Outdoor Connecting Wiring (mm ²)	Ground Wiring	2.5
	Strong Electric Signal	4×1.0(4×2.5 with auxiliary electric heater)
	Weak Electric Signal	

Product Features

Contents

1.	Operation Modes and Functions	29
1.1	Abbreviations	29
1.2	Safety Features	29
1.3	Digital Display.....	29
1.4	Fan.....	30
1.5	Cooling Mode	30
1.6	Heating Mode	30
1.7	Auto Mode.....	32
1.8	Drying Mode	32
1.9	Forced Operation Function	32
1.10	Timer Function	32
1.11	ECO Function	32
1.12	Auto-Restart.....	32
1.13	Drain Pump Control.....	33
1.14	8°C Heating Control(optional)	33
1.15	Self clean Control(optional)	33
1.16	Follow Me(optional).....	33
1.17	Silence Control(optional)	33
2.	Remote Controller Functions	34
2.1	LCD Wired Remote Controller.....	34
2.2	Centralized Controller	38

1. Operation Modes and Functions

1.1 Abbreviation

Unit element abbreviations

Abbreviation	Element
T1	Indoor room temperature
T2	Coil temperature of evaporator
T3	Coil temperature of condenser
T4	Outdoor ambient temperature
TP	Compressor discharge temperature
Tsc	Adjusted setting temperature

In this manual, such as CDIFTEMP, HDIFTEMP2, TCE1, TCE2...etc., they are well-setting parameter of EEPROM.

1.2 Safety Features

Compressor three-minute delay at restart

Compressor functions are delayed for up to ten seconds upon the first startup of the unit, and are delayed for up to three minutes upon subsequent unit restarts.

Automatic shutoff based on discharge temperature

If the compressor discharge temperature exceeds a certain level for nine seconds, the compressor ceases operation.

Automatic shutoff based on fan speed

For Duct type:

If a fault occurs on the air volume regulator or the regulator enters protection mode, it sends the error message CF and an instruction to reduce fan speed to the master. The message and the instruction can be inquired with the remote controller or the wired controller. (Fault and protection information are displayed for one minute). After a fault occurs, the master unit shows the error code E3 and the fault count for one minute. If the fault occurs three times, then the fan is unable to resolve the problem independently. External shutdown by a remote controller, wired controller, or central controller must be used to clear the fan fault and fault count. The fan runs normally for 5 minutes while clearing fault count.

0	No malfunction
1	P0 Overcurrent
2	Overpressure
3	Overload
4	Over speed
5	Startup malfunction

6	Lack of phase
7	DC voltage too low
8	Communication fault
9	Parameter fault
10	L3 Current limited
11	L5 Voltage limited
12	Target speed cannot be met during the static pressure calculation process

For other types

If the indoor fan speed registers below 200RPM or over 2100RPM for an extended period of time, the unit ceases operation

Inverter module protection

The inverter module has an automatic shutoff mechanism based on the unit's current, voltage, and temperature. If automatic shutoff is initiated, the corresponding error code is displayed on the indoor unit and the unit ceases operation.

Indoor fan delayed operation

- When the unit starts, the louver is automatically activated and the indoor fan will operate after a period of setting time or the louver is in place.
- If the unit is in heating mode, the indoor fan is regulated by the anti-cold wind function.

Compressor preheating

Preheating is automatically activated when T4 sensor is lower than setting temperature.

Sensor redundancy and automatic shutoff

- If one temperature sensor malfunctions, the air conditioner continues operation and displays the corresponding error code, allowing for emergency use.
- When more than one temperature sensor is malfunctioning, the air conditioner ceases operation.

1.3 Display Function

Unit display functions

Cassette 650x650 BOX-SL 2

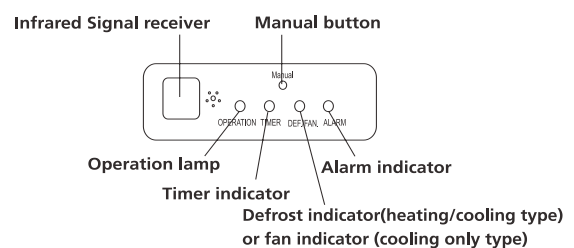

1.4 Fan Mode

When fan mode is activated:

- The outdoor fan and compressor are stopped.
- Temperature control is disabled and no temperature setting is displayed.
- The indoor fan speed can be set to 1%~100%, or low, medium, high and auto.
- The louver operations are identical to those in cooling mode.
- Auto fan: In fan-only mode, AC operates the same as auto fan in cooling mode with the temperature set at 24°C.

1.5 Cooling Mode

1.5.1 Compressor Control

Reach the configured temperature:

- 1) When the compressor runs continuously for less than 120 minutes.
 - If the following conditions are satisfied, the compressor ceases operation.
 - While calculated frequency(fb) is less than minimum limit frequency(FminC).
 - While protective time is more than or equal to ten minutes.
 - While T1 is lower than or equal to (Tsc-CDIFTEMP-0.5°C)
- 2) When the compressor runs continuously for more than 120 minutes.
 - If the following conditions are satisfied, the compressor ceases operation.
 - When calculated frequency(fb) is less than minimum limit frequency(FminC).
 - When protective time is more than or equal to ten minutes.
 - When T1 is lower than or equal to (Tsc-CDIFTEMP).
- 3) If one of the following conditions is satisfied, not judge protective time.
 - Compressor running frequency is more than test frequency.
 - When compressor running frequency is equal to test frequency, T4 is more than 15°C or no T4 or T4 fault.
 - Change setting temperature.
 - Turbo or sleep function on/off
 - Various frequency limit shutdown occurs.

1.5.2 Indoor Fan Control

- 1) In cooling mode, the indoor fan operates continuously. The fan speed can be set to 1%-100%, or low, medium, high and auto.
- 2) Auto fan action in cooling mode:
 - Descent curve
 - When T1-Tsc is lower than or equal to 3.5°C, fan speed reduces to 80%;
 - -When T1-Tsc is lower than or equal to 1°C, fan speed reduces to 60%;
 - -When T1-Tsc is lower than or equal to 0.5°C, fan speed reduces to 40%;
 - -When T1-Tsc is lower than or equal to 0°C, fan speed reduces to 20%;
 - -When T1-Tsc is lower than or equal to -0.5°C, fan speed reduces to 1%.
 - Rise curve
 - When T1-Tsc is higher than 0°C, fan speed increases to 20%;
 - -When T1-Tsc is higher than 0.5°C, fan speed increases to 40%;
 - -When T1-Tsc is higher than 1°C, fan speed increases to 60%;
 - -When T1-Tsc is higher than 1.5°C, fan speed increases to 80%;
 - -When T1-Tsc is higher than 4°C, fan speed increases to 100%.

1.5.3 Outdoor Fan Control

- The outdoor unit will be run at different fan speed according to T4 and compressor frequency.
- For different outdoor units, the fan speeds are different.

1.5.4 Condenser Temperature Protection

When the condenser temperature exceeds a configured value, the compressor ceases operation.

1.5.5 Evaporator Temperature Protection

When evaporator temperature drops below a configured value, the compressor and outdoor fan cease operation.

1.6 Heating Mode(Heat Pump Units)

1.6.1 Compressor Control

- 1) Reach the configured temperature
 - If the following conditions are satisfied, the compressor ceases operation.
 - While calculated frequency(fb) is less than

minimum limit frequency(FminH).

- When protective time is more than or equal to ten minutes.
- When T1 is higher than or equal to Tsc+ HDIFTEMP2.

Note: HDIFTEMP2 is EEPROM setting parameter. It is 2°C usually.

- If one of the following conditions is satisfied, not judge protective time.
 - Compressor running frequency is more than test frequency.
 - When compressor running frequency is equal to test frequency, T4 is more than 15°C or no T4 or T4 fault.
 - Change setting temperature.
 - Turbo or sleep function on/off.
- 2) When the current is higher than the predefined safe value, surge protection is activated, causing the compressor to cease operations.

1.6.2 Indoor Fan Control:

- 1) In heating mode, the indoor fan operates continuously. The fan speed can be set to 1%-100%, or low, medium, high and auto.
- . Anti-cold air function
 - The indoor fan is controlled by the indoor temperature T1 and indoor unit coil temperature T2.

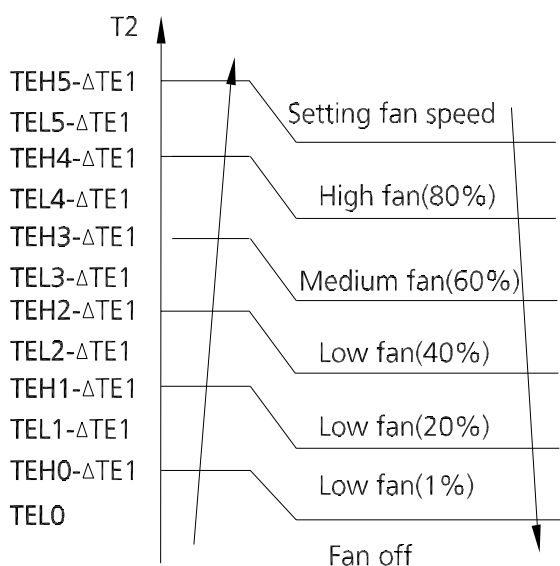

ΔTE1=0

2) Auto fan action in heating mode:

- Rise curve
 - When T1-Tsc is higher than -1.5°C, fan speed reduces to 80%;
 - -When T1-Tsc is higher than 0°C, fan speed reduces to 60%;
 - -When T1-Tsc is higher than 0.5°C, fan speed reduces to 40%;
 - -When T1-Tsc is higher than 1°C, fan speed reduces to 20%.
- Descent curve
 - When T1-Tsc is lower than or equal to 0.5°C, fan speed increases to 20%;
 - -When T1-Tsc is lower than or equal to 0°C, fan speed increases to 60%;
 - -When T1-Tsc is lower than or equal to -1.5°C, fan speed increases to 80%;
 - -When T1-Tsc is lower than or equal to -3°C, fan speed increases to 100%.

1.6.3 Outdoor Fan Control:

- The outdoor unit will be run at different fan speed according to T4 and compressor frequency.
- For different outdoor units, the fan speeds are different.

1.6.4 Defrosting mode

Case 1:

- The unit enters defrosting mode according to the temperature value of T3 and T4 as well as the compressor running time.
- In defrosting mode, the compressor continues to run, the indoor and outdoor motor will cease operation, the defrost light of the indoor unit will turn on, and the "df" symbol is displayed.
- If any one of the following conditions is satisfied, defrosting ends and the machine switches to normal heating mode:
 - T3 rises above TCDE1.
 - T3 maintained above TCDE2 for 80 seconds.
 - Unit runs for 15 minutes consecutively in defrosting mode.

1.6.5 Evaporator Coil Temperature Protection

- When the evaporator temperature exceeds a preset protection value, the compressor ceases operation.

1.7 Auto Mode

- This mode can be selected with the remote controller and the temperature setting can be adjusted between 16°C~30°C.
- In auto mode, the machine selects cooling, heating, or fan-only mode on the basis of ΔT ($\Delta T = T1 - TS$).

ΔT	Running mode
$\Delta T > 2^{\circ}\text{C}$ (3.6°F)	Cooling
-3°C (-5.4°F) $\leq \Delta T \leq 2^{\circ}\text{C}$ (3.6°F)	Fan-only
$\Delta T < -3^{\circ}\text{C}$ (-5.4°F)	Heating*

Heating*: In auto mode, cooling only models run the fan

- Indoor fan will run at auto fan speed.
- The louver operates same as in relevant mode.
- If the machine switches mode between heating and cooling, the compressor will keep stopping for certain time and then choose mode according to ΔT .

1.8 Drying Mode

- In drying mode, AC operates the same as auto fan in cooling mode.
- All protections are activated and operate the same as they do that in cooling mode.
- Low Room Temperature Protection

If the room temperature is lower than 10°C, the compressor ceases operations and does not resume until room temperature exceeds 12°C.

1.9 Forced Operation Function

Press the AUTO/COOL button, the AC will run as below sequence:

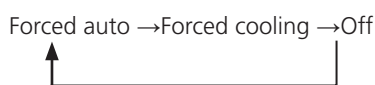

- Forced cooling mode:

The compressor and outdoor fan continue to run and the indoor fan runs at breeze speed. After running for 30 minutes, the AC will switch to auto mode with a preset temperature of 24°C(76°F).

- Forced auto mode:

Forced auto mode operates the same as normal auto mode with a preset temperature of 24°C(76°F).

- The unit exits forced operation when it receives the following signals:
 - Switch off
 - Changes in:
 - mode

- fan speed
- sleep mode
- Follow me

1.10 Timer Function

- The timing range is 24 hours.
- Timer On. The machine turns on automatically at the preset time.
- Timer Off. The machine turns off automatically at the preset time.
- Timer On/Off. The machine turns on automatically at the preset On Time, and then turns off automatically at the preset Off Time.
- Timer Off/On. The machine turns on automatically at the preset Off Time and then turns off automatically at the preset On Time.
- The timer does not change the unit operation mode. If the unit is off now, it does not start up immediately after the "timer off" function is set. When the setting time is reached, the timer LED switches off and the unit running mode remains unchanged.
- The timer uses relative time, not clock time

1.11 ECO Function

- The ECO function is available in cooling, heating, or auto mode.
- The operational process for sleep mode is as follows:
 - When cooling, the temperature rises 1°C (to not higher than 30°C) every hour. After 2 hours, the temperature stops rising and the indoor fan is fixed at low speed.
 - When heating, the temperature decreases 1°C (to not lower than 17°C) every hour. After 2 hours, the temperature stops decreasing and the indoor fan is fixed at low speed. Anti-cold wind function takes priority.
- The operating time for sleep mode is 8 hours, after which, the unit exits this mode and does not switches off.

1.12 Auto-Restart function

- The indoor unit has an auto-restart module that allows the unit to restart automatically. The module automatically stores the current settings and in the case of a sudden power failure, will restore those setting automatically within 3 minutes after power returns.

1.13 Drain Pump Control(Standard for cassette type)

- Use the water-level switch to control drain pump.
- The system checks the water level every 5 seconds.
- When the A/C operates in cooling, the pump begins running immediately and continuously until cooling stops.
- When the A/C operates in forced cooling mode and defrosting mode, the pump is running continuously.
- If the water level increases up to the control point, the LED displays an alarm code and the drain pump opens and continually monitors the water level. If the water level falls and LED alarm code is no longer displayed (drain pump close delay is 1 minute), the unit goes back into its last mode. Otherwise, the entire system (including the pump) stops and the LED displays an alarm again after 3 minutes.

1.14 8°C Heating(Optional)

In heating mode, the temperature can be set to as low as 8°C, preventing the indoor area from freezing if unoccupied during severe cold weather.

1.15 Self Clean(Optional)

- If you press “Self Clean” when the unit is in cooling, drying, auto cooling or auto drying mode:
 - The indoor unit will run in low fan mode for a certain time, then ceases operation.
- Self Clean keeps the indoor unit dry and prevents mold growth.
- When match with multi outdoor unit, this function is disabled.

1.16 Follow me(Optional)

- If you press “Follow Me” on the remote, the indoor unit will beep. This indicates the follow me function is active.
- Once active, the remote control will send a signal every 3 minutes, with no beeps. The unit automatically sets the temperature according to the measurements from the remote control.
- The unit will only change modes if the information from the remote control makes it necessary, not from the unit’s temperature setting.
- If the unit does not receive a signal for 7 minutes or you press “Follow Me,” the function turns off. The unit regulates temperature based on its own sensor and settings.

1.17 Silence(Optional)

- Press “Silence” on the remote control to enable the SILENCE function. While this function is active, the compressor frequency is maintained at a lower level than F3. The indoor unit will run at faint breeze(1%), which reduces noise to the lowest possible level.
- When match with multi outdoor unit, this function is disabled.

2. Remote Controller Functions

2.1 LCD Wired Remote Controller KJR-120C1E(Optional)

The KJR-120C1E wired remote controller is optional for all types.

i) Buttons and Functions

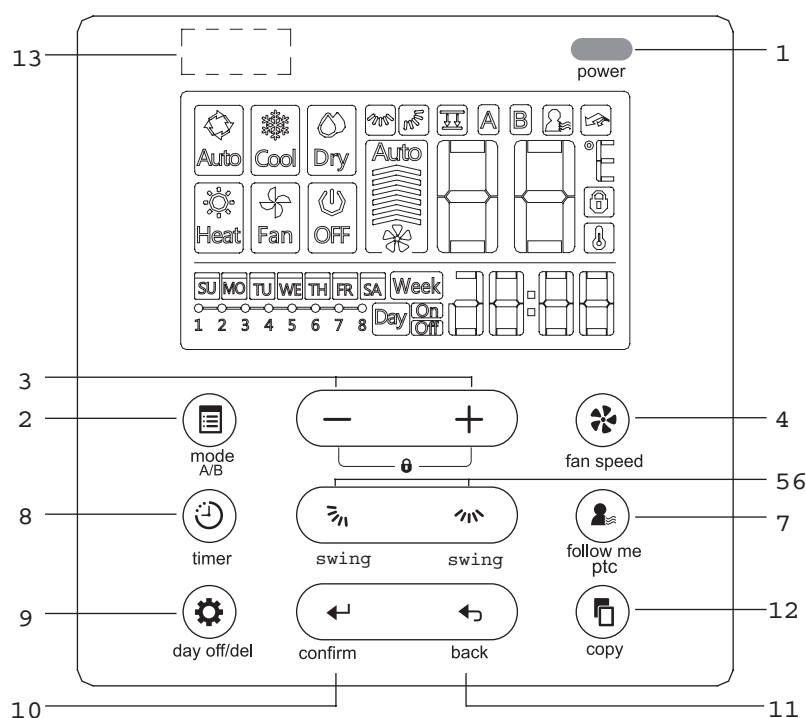

1. POWER button

Turn on or turn off the unit.

2. MODE(A/B) button

Used to select the operation mode: Auto / Cooling / Drying / Heating / Fan;

Hold to activate the operation of auto-lifting panel when off

3. Adjust button

To set temperature, time and timer; set up or down the auto-lifting panel

4. FAN SPEED button

Used to select the fan speed.

5. Up-down airflow direction and swing Button

Press for adjusting the angle of louver, hold for vertical swing; individual louver control for cassette panel

6. Left-right airflow swing Button

Press for activating the horizontal swing

7. FOLLOW ME(PTC) button

Allows the remote control to act as a remote thermostat and send temperature information from its current location.

8. TIMER button

To set timer on and timer off time of one day

9. DELAY/DAY OFF button

To set 1 to 2 hours delay off for each day or a whole day off in a weekly timer schedule

10. CONFIRM button

To confirm an setting or call up the menu

11. BACK button

Back to previous operation or superior menu

12. COPY button

Copy timer setting of one day to another in weekly schedule setting

13 Infrared remote receiver (on some models)

ii) LCD Screen

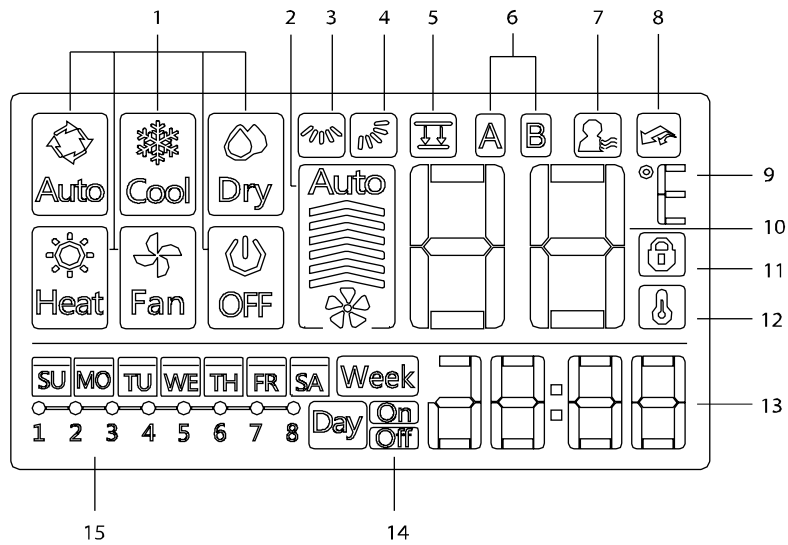

1 Operation mode indication

2 Fan speed indication

3 Left-right swing indication

4 Up-down swing indication

5 Faceplate function indication

6 Main unit and secondary unit indication

7 Follow me function indication

8 PTC function indication

9 C° / F° indication

10 Temperature display

11 Lock indication

12 Room temperature indication

13 Clock display

14 On/Off timer

15 Timer display

i) Installation

• Dimensions

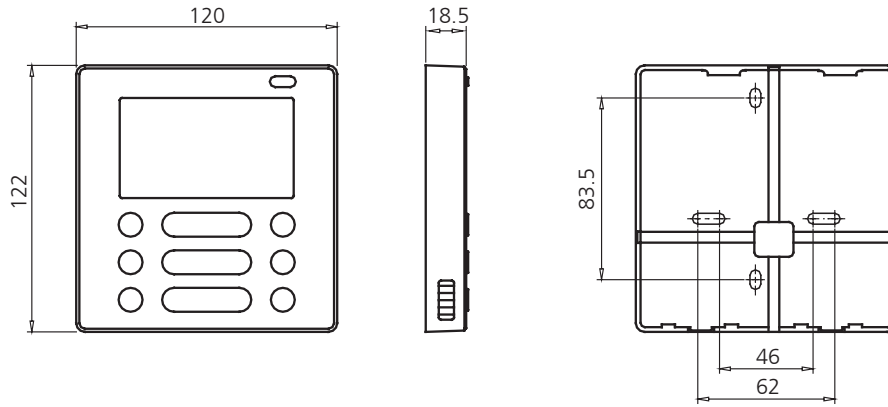

• Wiring diagram

Refer to the following diagram to wire the wall-mounted remote control to the indoor unit.

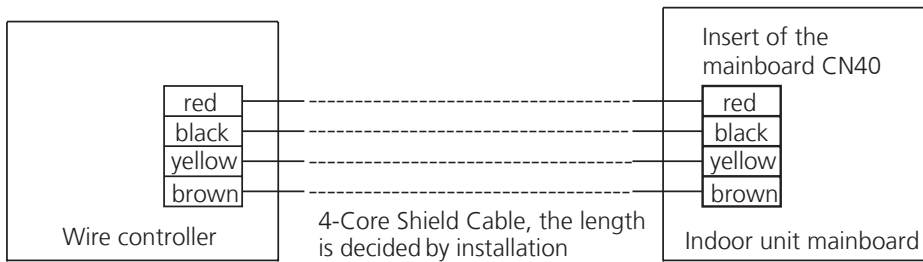

• Installation Diagram

Connect the female joint of wires group from the mainboard with the male joint of connective wires group. Then connect the other side of connective wires group with the male joint of wires group leads from wire controller.

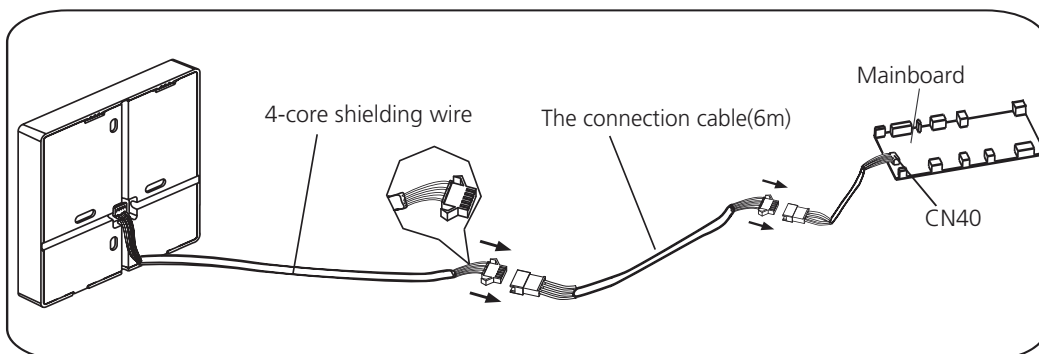

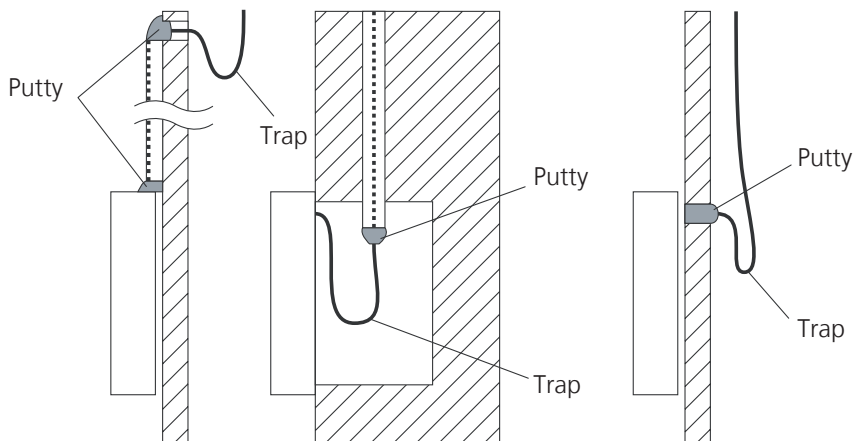

Note: DO NOT allow water to enter the remote control. Use the trap and putty to seal the wires.

- For exposed mounting, four outletting positions. There are three need cutting.

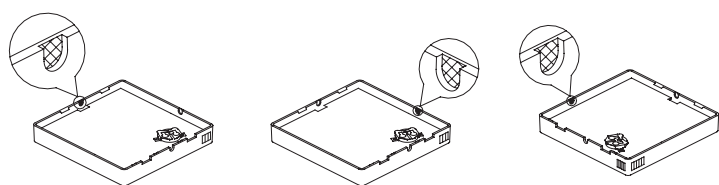

Cutting place of top side wire outlet

Cutting place of left side wire outlet

Cutting place of right side wire outlet

- For shielded wiring, please refer to the picture below.

Embedded switch box wiring

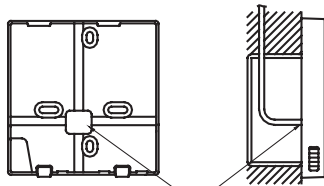

Wiring hole

Wiring through the wall

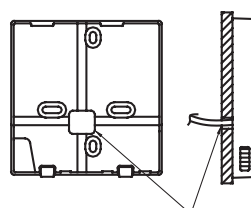

Wall hole and wiring hole
Diameter of wall hole: $\Phi 2\text{cm}$

2.2 Centralized Controller

1) Connection

For Light commercial air conditioner with XYE port, it can be directly connected to Centralized Controller (CCM03, CCM09).

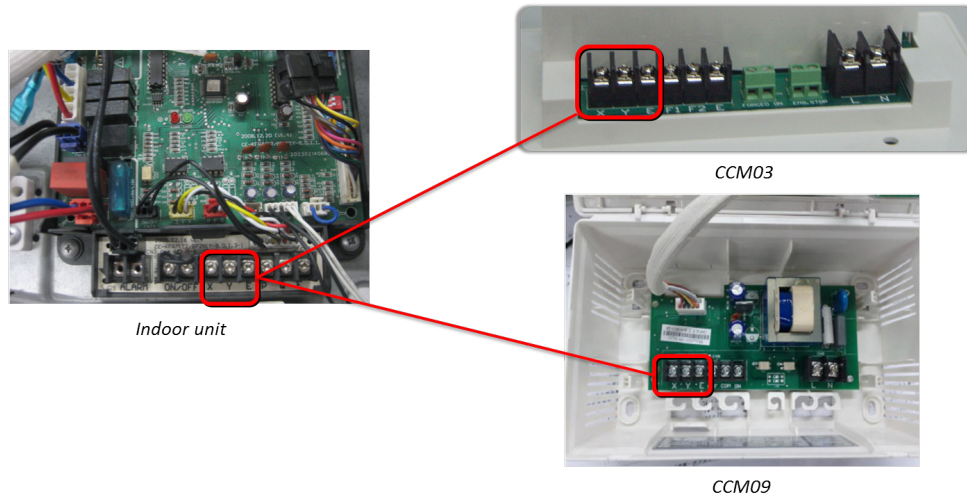

2) Address setting

When setting the address, please make sure the unit is powered off. The address can be set from 0 to 63 by the switch. Turn on the unit, then the address will be effective.

SWITCH		FOR CCM UNIT ADDRESS			
S2 + S1					
ADDRESS	0~15		16~31		
Factory Setting	✓				
S2 + S1					
ADDRESS	32~47		48~63		
Factory Setting					

Note: For light commercial air conditioner with XYE port, it can be also connected to BMS (Building Management System).











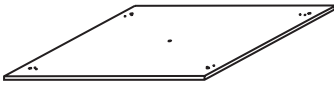

If there is any CAC (central air conditioner) connecting with the central controller at the same time, please set the address from largest (63,62,61...), since the CAC units could obtain address automatically from the smallest (00,01,02...)

Installation

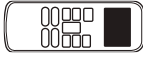
Contents

Accessories	40
1. Installation Overview	41
2. Location Selection	42
3. Indoor Unit Installation	43
4. Outdoor Unit Installation	44
5. Drainage Pipe Installation	45
6. Refrigerant Pipe Installation	47
7. Vacuum Drying and Leakage Checking	49
8. Additional Refrigerant Charge	50
9. Engineering of Insulation	50
10. Engineering of Electrical Wiring	51
11. Panel Installation	52
12. Test Operation	53

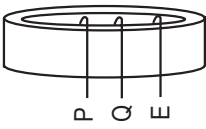
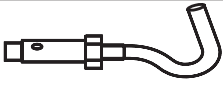
Accessories

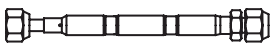
	Name	Shape	Quantity
Indoor unit installation	Installation paper template (some models)		1
Refrigeration Fittings	Soundproof/insulation sheath (some models)		1
Drainpipe Fittings	Outlet pipe sheath(some models)		1
	Outlet pipe clasp(some models)		1
	Drain joint (some models)		1
	Seal ring (some models)		1
Remote controller & Its Frame (some models)	Remote controller		1
	Fixing screw for remote controller holder ST2.9 x 10		2
	Remote controller holder		1
	Dry battery AAA		2
	Remote controller illustration		1
EMC Magnetic Ring (some models)	Magnetic ring (wrap the electric wires S1 & S2 (P & Q & E) around the magnetic ring twice)		1
Installation Accessory (some models)	Ceiling hook		4
	Suspension bolt		4
	Orifice tube (some units)		1
	Installation and operating manual		1

1. Installation Overview

Installation Order

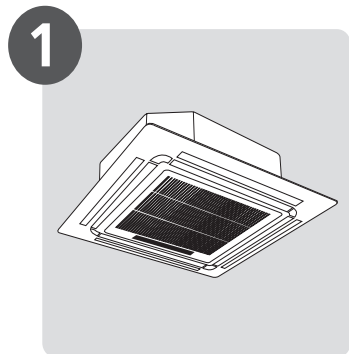

Install the indoor unit

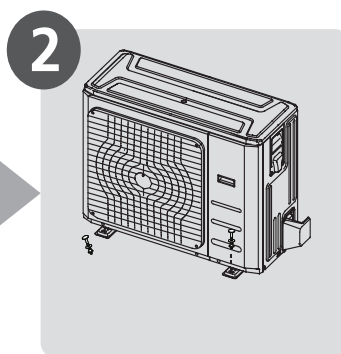

Install the outdoor unit

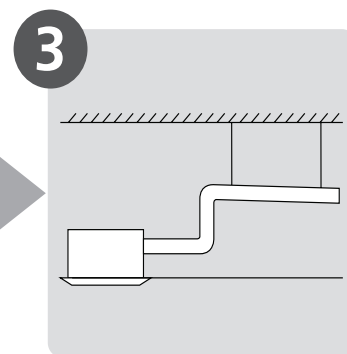

Install the drainpipe

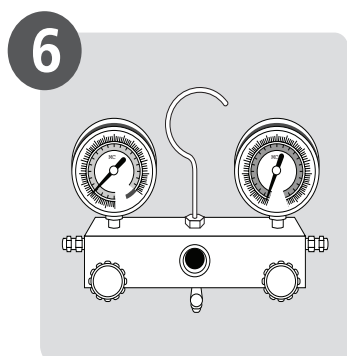

Evacuate the refrigeration system

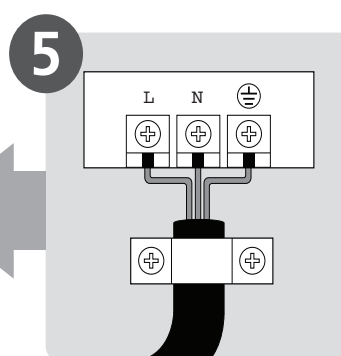

Connect the wires

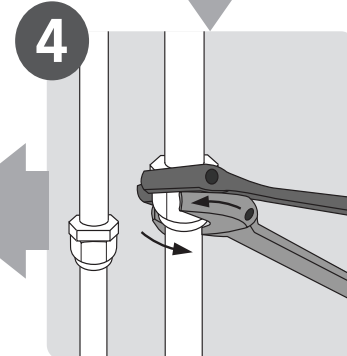

Connect the refrigerant pipes

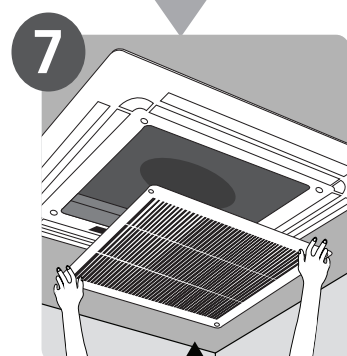

Install the front panel

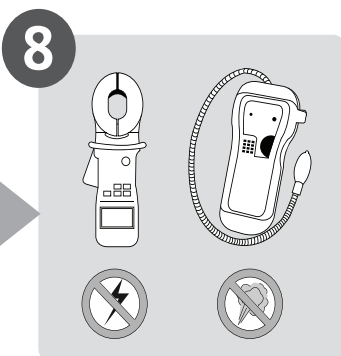

Perform a test run

2. Location selection

2.1 Unit location selection can refer to installation manual.

2.2 DO NOT install the unit in the following locations:

- Where oil drilling or fracking is taking place.
- Coastal areas with high salt content in the air.
- Areas with caustic gases in the air, such as near hot springs.
- Areas with power fluctuations, such as factories.
- Enclosed spaces, such as cabinets.
- Areas with strong electromagnetic waves.
- Areas that store flammable materials or gas.
- Rooms with high humidity, such as bathrooms or laundry rooms.
- If possible, DO NOT install the unit where it is exposed to direct sunlight.

2.3 The minimum distance between the outdoor unit and walls described in the installation guide does not apply to airtight rooms. Be sure to keep the unit unobstructed in at least two of the three directions (M, N, P)

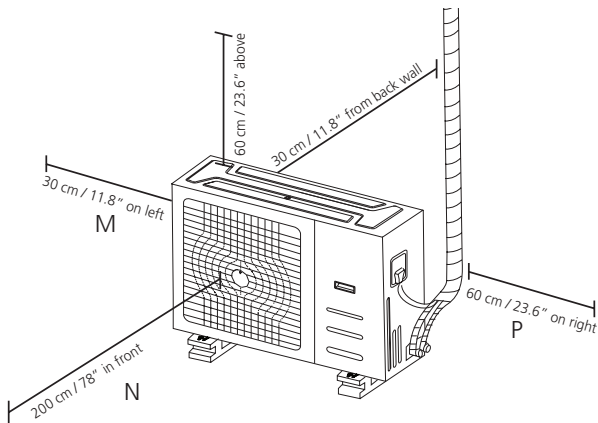

2.4 Rows of series installation

The relations between H, A and L are as follows.

	L	A
$L \leq H$	$L \leq 1/2H$	25 cm / 9.8" or more
	$1/2H < L \leq H$	30 cm / 11.8" or more
$L > H$	Can not be installed	

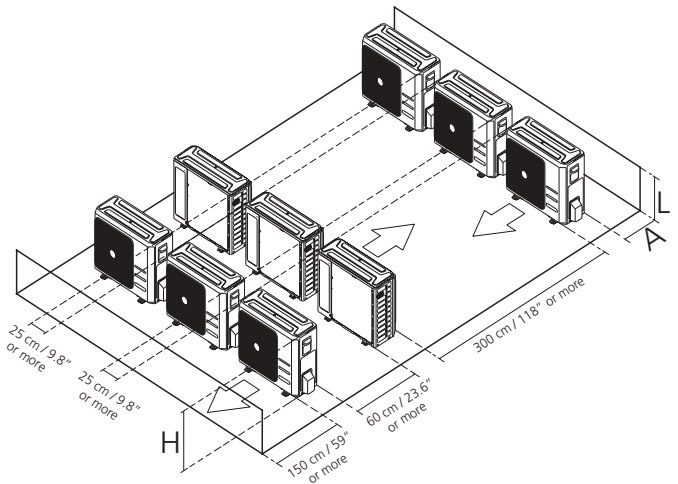

DO NOT install the rows of series like following figure.

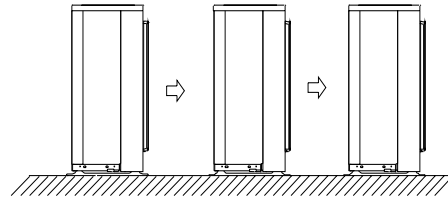

2.5. If the location is exposed to strong winds (for example: near a seaside), the unit must be placed against the wall to shelter it from the wind. If necessary, use an windbreaks (or similar).

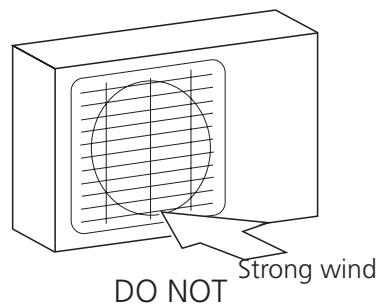

3. Indoor Unit Installation

3.1 Service space for indoor unit

For Cassette 650x650 BOX-SL 2

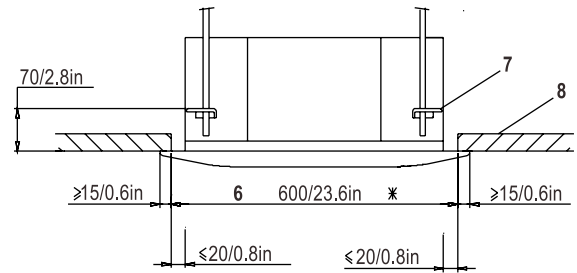
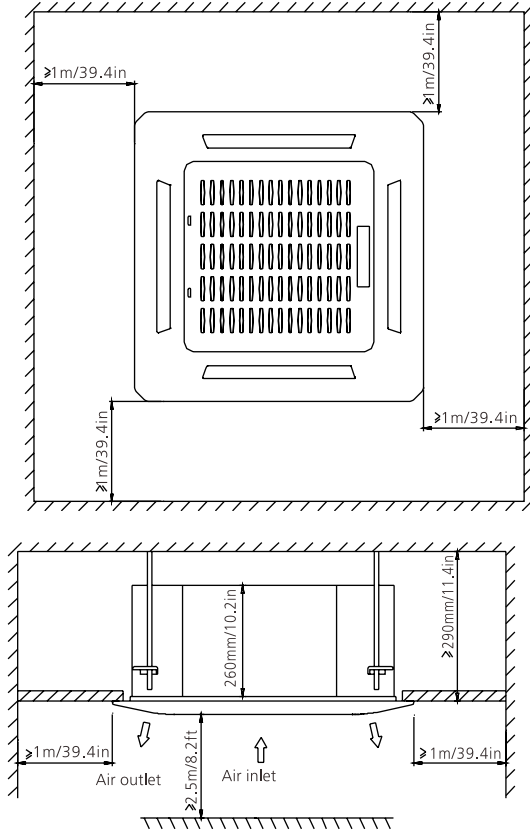

- 1 Suspension bolt pitch dimensions
- 2 Body dimensions
- 3 Decoration panel dimensions
- 4 Refrigerant piping
- 5 Suspension bolt (x4)
- 6 Ceiling opening dimensions
- 7 Hanger bracket
- 8 Ceiling board

2. Drill 4 holes 5cm (2") deep at the ceiling hook positions in the internal ceiling. Be sure to hold the drill at a 90° angle to the ceiling.
3. Using a hammer, insert the ceiling hooks into the pre-drilled holes. Secure the bolt using the included washers and nuts.
4. Install the four suspension bolts



3.2 Hang Indoor Unit

1. Use the included paper template to cut a rectangular hole in the ceiling, leaving at least 1m (39.4") on all sides. The cut hole size should be 4cm (1.6") larger than the body size.

Be sure to mark the areas where ceiling hook holes will be drilled.

For Cassette 650x650 BOX-SL 2

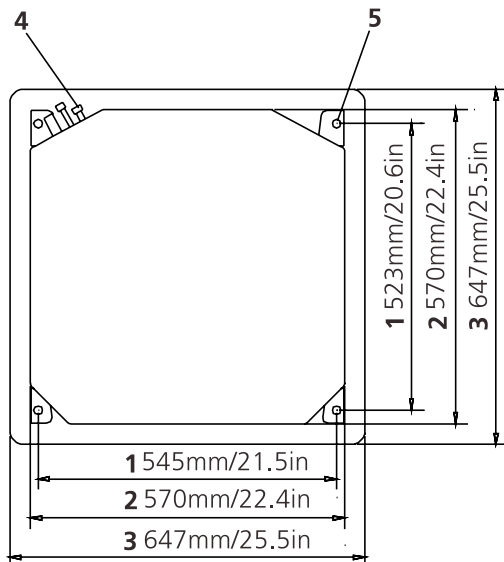

5. Mount the indoor unit. You will need two people to lift and secure it. Insert suspension bolts into the unit's hanging holes. Fasten them using the included washers and nuts

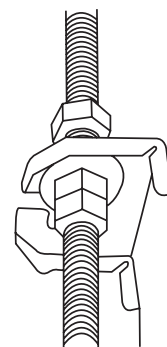

Adjust the position to ensure the gaps between the indoor unit and the four sides of false ceiling are even. The bottom of the unit should be 24mm / 0.9in(compact cassette) / 10 - 18mm (0.4-0.7") (super-slim cassette) higher than ceiling board.

Generally, L should be half the length of the suspension bolt or long enough to prevent the nuts from coming off

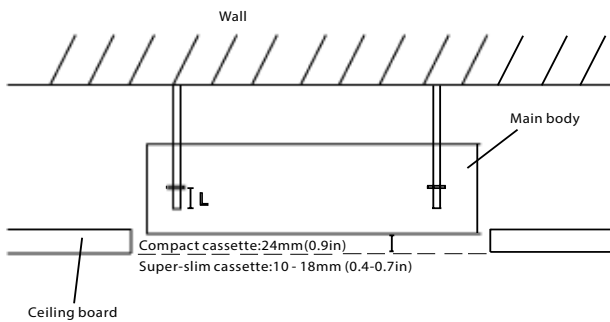

CAUTION:

Ensure that the unit is completely level.

The unit is equipped with a built-in drain pump and float switch. If the unit is tilted against the direction of condensate flows (the drainpipe side is raised), the float switch may malfunction and cause water to leak.

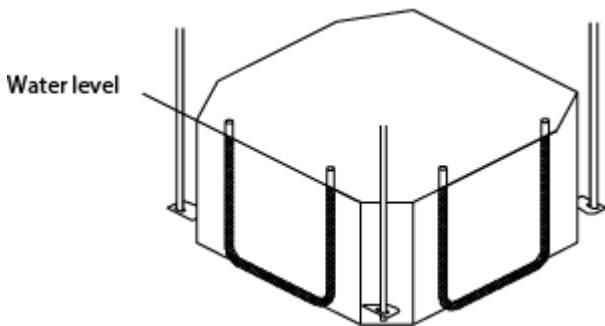

NOTE FOR NEW HOME INSTALLATION

When installing the unit in a new home, the ceiling hooks can be embedded in advance. Make sure that the hooks do not come loose due to concrete shrinkage. After installing the indoor unit, fasten the installation paper template onto the unit with bolts (M6X12) to determine in advance the dimension and position of the opening on the ceiling. Follow the instructions above for the remainder of the installation.

4. Outdoor unit installation

4.1 Service space for outdoor unit

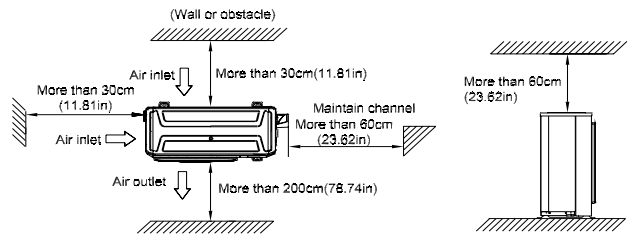

4.2 Bolt pitch

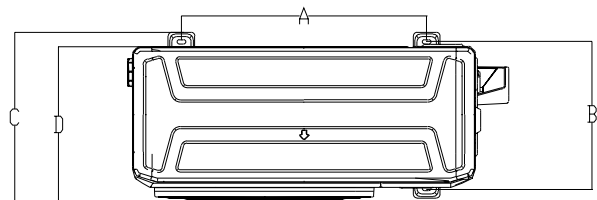

Model	Unit	D	A	B	C
MC2-Y 53M	mm	333	514	340	365
	inch	13.11	20.23	13.39	14.37

4.2 Install Outdoor Unit

Fix the outdoor unit with anchor bolts(M10)

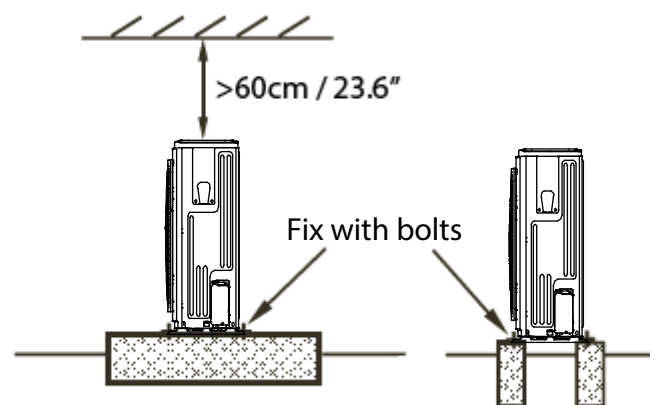

Caution

Since the gravity center of the unit is not at its physical center, so please be careful when lifting it with a sling.

Never hold the inlet of the outdoor unit to prevent it from deforming.

Do not touch the fan with hands or other objects.

Do not lean it more than 45°, and do not lay it sidelong.

Make concrete foundation according to the specifications of the outdoor units.

Fasten the feet of this unit with bolts firmly to prevent it from collapsing in case of earthquake or strong wind.

5. Drainage Pipe Installation

Install the drainage pipe as shown below and take measures against condensation. Improper installation could lead to leakage and eventually wet furniture and belongings.

5.1 Installation principle

- Ensure at least 1/100 slope of the drainage pipe
- Adopt suitable pipe diameter
- Adopt nearby condensate water discharge

5.2 Key points of drainage water pipe installation

1. Considering the pipeline route and elevation.
 - Before installing condensate water pipeline, determine its route and elevation to avoid intersection with other pipelines and ensure slope is straight.
2. Drainage pipe selection
 - The drainage pipe diameter shall not be smaller than the drain hose of indoor unit
 - According to the water flowrate and drainage pipe slope to choose the suitable pipe, the water flowrate is decided by the capacity of indoor unit.

Relationship between water flowrate and capacity of indoor unit

Model	Water flowrate (l/h)
53M	4

According to the above table to calculate the total water flowrate for the confluence pipe selection.

For horizontal drainage pipe (The following table is for reference)

PVC pipe	Reference value of inner diameter of pipe (mm)	Allowable maximum water flowrate (l/h)		Remark
		Slope 1/50	Slope 1/100	
PVC25	20	39	27	For branch pipe
PVC32	25	70	50	
PVC40	31	125	88	Could be used for confluence pipe
PVC50	40	247	175	
PVC63	51	473	334	

Attention: Adopt PVC40 or bigger pipe to be the main pipe.

For Vertical drainage pipe (The following table is for reference)

PVC pipe	Reference value of inner diameter of pipe (mm)	Allowable maximum water flowrate (l/h)	Remark
PVC25	20	220	For branch pipe
PVC32	25	410	
PVC40	31	730	Could be used for confluence pipe
PVC50	40	1440	
PVC63	51	2760	
PVC75	67	5710	
PVC90	77	8280	

Attention: Adopt PVC40 or bigger pipe to be the main pipe.

3. Individual design of drainage pipe system

- The drainage pipe of air conditioner shall be installed separately with other sewage pipe, rainwater pipe and drainage pipe in building.
- The drainage pipe of the indoor unit with water pump should be apart from the one without water pump.

4. Supporter gap of drainage pipe

- In general, the supporter gap of the drainage pipe horizontal pipe and vertical pipe is respectively 1m~1.5m and 1.5m~2.0m.
- Each vertical pipe shall be equipped with not less than two hangers.
- Overlarge hanger gap for horizontal pipe shall create bending, thus leading to air block.

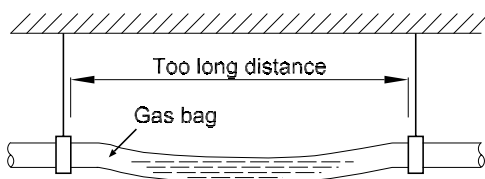

5. The horizontal pipe layout should avoid converse flow or bad flow

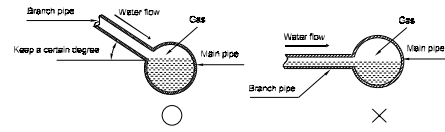
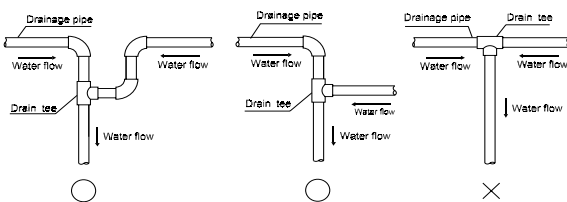

- The correct installation will not cause converse water flow and the slope of the branch pipes can be adjusted freely
- The false installation will cause converse water flow and the slope of the branch pipe can not be adjusted.

6. Water storage pipe setting

- If the indoor unit has high extra static pressure and without water pump to elevate the condensate water, such as high extra static pressure duct unit, the water storage pipe should be set to avoid converse flow or blow water phenomena.

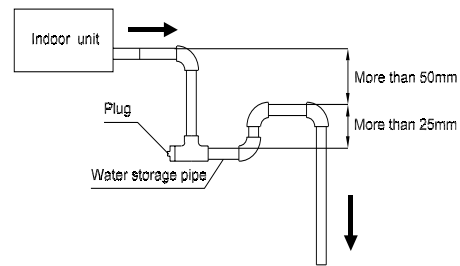

7. Lifting pipe setting of indoor unit with water pump

- The length of lifting pipe should not exceed 750mm/29.5in.
- The drainage pipe should be set down inclined after the lifting pipe immediately to avoid wrong operation of water level switch.
- Refer the following picture for installation reference.

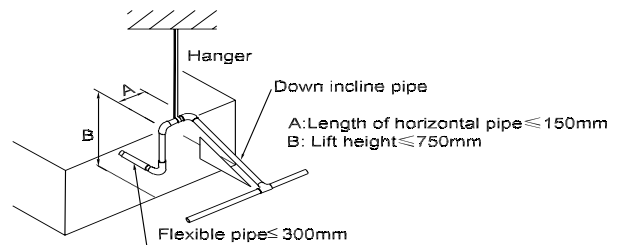

8. Blowhole setting

- For the concentrated drainage pipe system, there should design a blowhole at the highest point of main pipe to ensure the condensate water discharge smoothly.
- The air outlet shall face down to prevent dirt enter-

ing pipe.

- Each indoor unit of the system should be installed it.
- The installation should be considering the convenience for future cleaning.

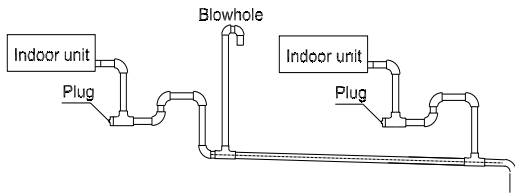

9. The end of drainage pipe shall not contact with ground directly.

5.3 Insulation work of drainage pipe

Refer the introduction to the insulation engineering parts.

6. Refrigerant Pipe Installation

6.1 Maximum length and drop height

Ensure that the length of the refrigerant pipe, the number of bends, and the drop height between the indoor and outdoor units meets the requirements shown in the following table.

Model	Max. Length (m/ft)	Max. Elevation (m/ft)
53M	30/98.4	20/65.6

Caution:

1. The capacity test is based on the standard length and the maximum permissible length is based on the system reliability.
2. Oil traps

If the indoor unit is installed higher than the outdoor unit:

-If oil flows back into the outdoor unit's compressor, this might cause liquid compression or deterioration of oil return. Oil traps in the rising gas piping can prevent this.

An oil trap should be installed every 10m(32.8ft) of vertical suction line riser.

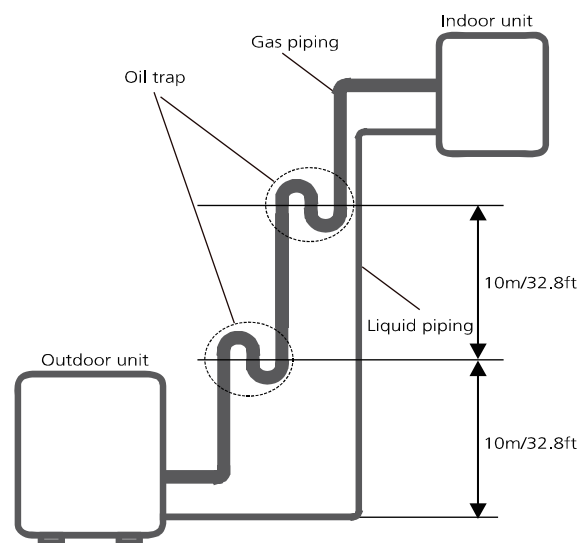

The indoor unit is installed higher than the outdoor unit

If the outdoor unit is installed higher than the indoor unit:

-It is recommended that vertical suction risers not be upsized. Proper oil return to the compressor should be maintained with suction gas velocity. If velocities drop below 7.62m/s(1500fpm (feet per minute)), oil return will be decreased. An oil trap should be installed every 6m(20ft) of vertical suction line riser.

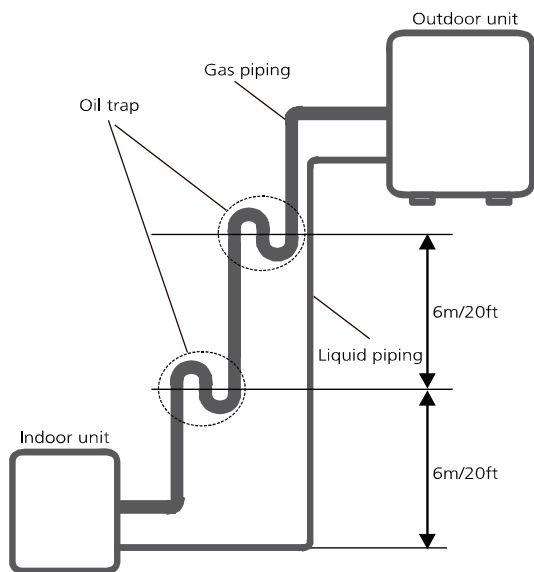

The outdoor unit is installed higher than the indoor unit

6.2 The procedure of connecting pipes

1. Choose the pipe size according to the specification table.
2. Confirm the cross way of the pipes.
3. Measure the necessary pipe length.
4. Cut the selected pipe with pipe cutter
 - Make the section flat and smooth.

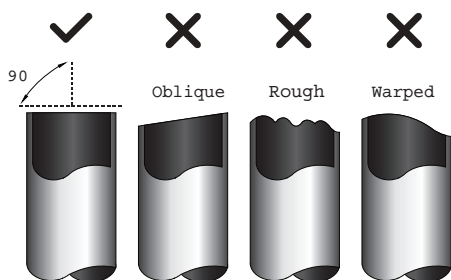

5. Insulate the copper pipe
 - Before test operation, the joint parts should not be heat insulated.
6. Flare the pipe
 - Insert a flare nut into the pipe before flaring the pipe
 - According to the following table to flare the pipe.

Pipe diameter (inch(mm))	Flare dimension A (mm/inch)		Flare shape
	Min	Max	
1/4" (6.35)	8.4/0.33	8.7/0.34	
3/8" (9.52)	13.2/0.52	13.5/0.53	
1/2" (12.7)	16.2/0.64	16.5/0.65	
5/8" (15.9)	19.2/0.76	19.7/0.78	
3/4" (19)	23.2/0.91	23.7/0.93	
7/8" (22)	26.4/1.04	26.9/1.06	

- After flared the pipe, the opening part must be seal by end cover or adhesive tape to avoid duct or exogenous impurity come into the pipe.
7. Drill holes if the pipes need to pass the wall.
 8. According to the field condition to bend the pipes so that it can pass the wall smoothly.
 9. Bind and wrap the wire together with the insulated pipe if necessary.
 10. Set the wall conduit
 11. Set the supporter for the pipe.
 12. Locate the pipe and fix it by supporter
 - For horizontal refrigerant pipe, the distance between supporters should not be exceed 1m.
 - For vertical refrigerant pipe, the distance between supporters should not be exceed 1.5m.
 13. Connect the pipe to indoor unit and outdoor unit by using two spanners.
 - Be sure to use two spanners and proper torque to fasten the nut, too large torque will damage the bellmouthing, and too small torque may cause leakage. Refer the following table for different pipe connection.

Pipe Diameter	Torque	Sketch map
	N.m(lb.ft)	
1/4" (6.35)	15~16 (11~11.8)	
3/8" (9.52)	25~26 (18.4~19.18)	
1/2" (12.7)	35~36 (25.8~26.55)	
5/8" (15.9)	45~47 (33.19~34.67)	
3/4" (19)	65~67 (47.94~49.42)	
7/8" (22)	75~85 (55.3~62.7)	

7. Vacuum Drying and Leakage Checking

7.1 Purpose of vacuum drying

- Eliminating moisture in system to prevent the phenomena of ice-blockage and copper oxidation.
Ice-blockage shall cause abnormal operation of system, while copper oxide shall damage compressor.
- Eliminating the non-condensable gas (air) in system to prevent the components oxidizing, pressure fluctuation and bad heat exchange during the operation of system.

7.2 Selection of vacuum pump

- The ultimate vacuum degree of vacuum pump shall be -756mmHg or above.
- Precision of vacuum pump shall reach 0.02mmHg or above.

7.3 Operation procedure for vacuum drying

Due to different construction environment, two kinds of vacuum drying ways could be chosen, namely ordinary vacuum drying and special vacuum drying.

7.3.1 Ordinary vacuum drying

1. When conduct first vacuum drying, connect pressure gauge to the infusing mouth of gas pipe and liquid pipe, and keep vacuum pump running for 1 hour (vacuum degree of vacuum pump shall be reached -755mmHg).
2. If the vacuum degree of vacuum pump could not reach -755mmHg after 1 hour of drying, it indicates that there is moisture or leakage in pipeline system and need to go on with drying for half an hour.
3. If the vacuum degree of vacuum pump still could not reach -755mmHg after 1.5 hours of drying, check whether there is leakage source.
4. Leakage test: After the vacuum degree reaches -755mmHg, stop vacuum drying and keep the pressure for 1 hour. If the indicator of vacuum gauge does not go up, it is qualified. If going up, it indicates that there is moisture or leak source.

7.3.2 Special vacuum drying

The special vacuum drying method shall be adopted when:

1. Finding moisture during flushing refrigerant pipe.
2. Conducting construction on rainy day, because rain water might penetrated into pipeline.
3. Construction period is long, and rain water might penetrated into pipeline.

4. Rain water might penetrate into pipeline during construction.

Procedures of special vacuum drying are as follows:

1. Vacuum drying for 1 hour.
2. Vacuum damage, filling nitrogen to reach 0.5Kgf/cm².

Because nitrogen is dry gas, vacuum damage could achieve the effect of vacuum drying, but this method could not achieve drying thoroughly when there is too much moisture. Therefore, special attention shall be drawn to prevent the entering of water and the formation of condensate water.

3. Vacuum drying again for half an hour.

If the pressure reached -755mmHg, start to pressure leakage test. If it cannot reached the value, repeat vacuum damage and vacuum drying again for 1 hour.

4. Leakage test: After the vacuum degree reaches -755mmHg, stop vacuum drying and keep the pressure for 1 hour. If the indicator of vacuum gauge does not go up, it is qualified. If going up, it indicates that there is moisture or leak source.

8. Additional Refrigerant Charge

- After the vacuum drying process is carried out, the additional refrigerant charge process need to be performed.
- The outdoor unit is factory charged with refrigerant. The additional refrigerant charge volume is decided by the diameter and length of the liquid pipe between indoor and outdoor unit. Refer the following formula to calculate the charge volume.

Diameter of liquid pipe (mm)	Formula
6.35	$V=12g/m \times (L-5)$
9.52	$V=24g/m \times (L-5)$

V: Additional refrigerant charge volume (g).

L : The length of the liquid pipe (m).

Note:

- Refrigerant may only be charged after performed the vacuum drying process.
- Always use gloves and glasses to protect your hands and eyes during the charge work.
- Use electronic scale or fluid infusion apparatus to weight refrigerant to be recharged. Be sure to avoid extra refrigerant charged, it may cause liquid hammer of the compressor or protections.
- Use supplementing flexible pipe to connect refrigerant cylinder, pressure gauge and outdoor unit. And The refrigerant should be charged in liquid state. Before recharging, The air in the flexible pipe and manifold gauge should be exhausted.
- After finished refrigerant recharge process, check whether there is refrigerant leakage at the connection joint part.(Using gas leakage detector or soap water to detect).

9. Engineering of Insulation

9.1 Insulation of refrigerant pipe

1. Operational procedure of refrigerant pipe insulation

Cut the suitable pipe → insulation (except joint section) → flare the pipe → piping layout and connection → vacuum drying → insulate the joint parts

2. Purpose of refrigerant pipe insulation

- During operation, temperature of gas pipe and liquid pipe shall be over-heating or over-cooling extremely. Therefore, it is necessary to carry out insulation; otherwise it shall debase the performance of unit and burn compressor.
- Gas pipe temperature is very low during cooling. If insulation is not enough, it shall form dew and cause leakage.
- Temperature of gas pipe is very high (generally 50-100°C) during heating. Insulation work must be carried out to prevent hurt by carelessness touching.

3. Insulation material selection for refrigerant pipe

- The burning performance should over 120°C
- According to the local law to choose insulation materials
- The thickness of insulation layer shall be above 10mm. If in hot or wet environment place, the layer of insulation should be thicker accordingly.

4. Installation highlights of insulation construction

- Gas pipe and liquid pipe shall be insulated separately, if the gas pipe and liquid pipe were insulated together; it will decrease the performance of air conditioner.

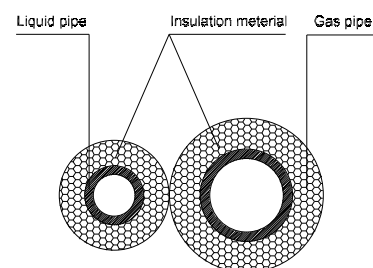

- The insulation material at the joint pipe shall be 5~10cm longer than the gap of the insulation material.
- The insulation material at the joint pipe shall be inserted into the gap of the insulation material.
- The insulation material at the joint pipe shall be banded to the gap pipe and liquid pipe tightly.
- The linking part should be use glue to paste together
- Be sure not bind the insulation material over-tight, it may extrude out the air in the material to cause bad

insulation and cause easy aging of the material.

9.2 Insulation of drainage pipe

1. Operational procedure of refrigerant pipe insulation

Select the suitable pipe → insulation (except joint section) → piping layout and connection → drainage test → insulate the joint parts

2. Purpose of drainage pipe insulation

The temperature of condensate drainage water is very low. If insulation is not enough, it shall form dew and cause leakage to damage the house decoration.

3. Insulation material selection for drainage pipe

- The insulation material should be flame retardant material, the flame retardancy of the material should be selected according to the local law.
- Thickness of insulation layer is usually above 10mm.
- Use specific glue to paste the seam of insulation material, and then bind with adhesive tape. The width of tape shall not be less than 5cm. Make sure it is firm and avoid dew.

4. Installation and highlights of insulation construction

- The single pipe should be insulated before connecting to another pipe, the joint part should be insulated after the drainage test.
- There should be no insulation gap between the insulation material.

10. Engineering of Electrical Wiring

1. Highlights of electrical wiring installation

- All field wiring construction should be finished by qualified electrician.
- Air conditioning equipment should be grounded according to the local electrical regulations.
- Current leakage protection switch should be installed.
- Do not connect the power wire to the terminal of signal wire.
- When power wire is parallel with signal wire, put wires to their own wire tube and remain at least 300mm gap.
- According to table in indoor part named "the specification of the power" to choose the wiring, make sure the selected wiring not small than the date showing in the table.
- Select different colors for different wire according to relevant regulations.
- Do not use metal wire tube at the place with acid or alkali corrosion, adopt plastic wire tube to replace it.
- There must be not wire connect joint in the wire tube If joint is a must, set a connection box at the place.
- The wiring with different voltage should not be in one wire tube.
- Ensure that the color of the wires of outdoor and the terminal No. are same as those of indoor unit respectively.

Table: Minimum Cross-Sectional Area able of Power and Signal Cables

Rated Current of Appliance (A)	Nominal Cross-Sectional Area(mm ²)
≤ 6	0.75
6 - 10	1
10 - 16	1.5
16 - 25	2.5
25 - 32	4
32 - 45	6

11. Panel Installation

11.1

11.2 Cassette 650x650 BOX-SL 2 Panel Installation

11.2.1 Remove the front grille

1. Slide the 2 grille hooks toward the middle of the decoration panel.

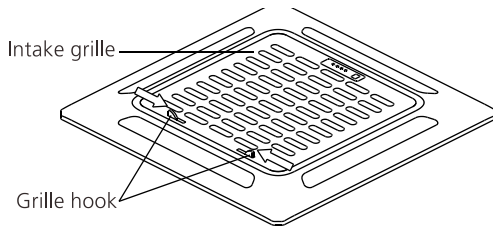

2. Hold the grille at a 45° angle, lift it up slightly and detach it from the main body.

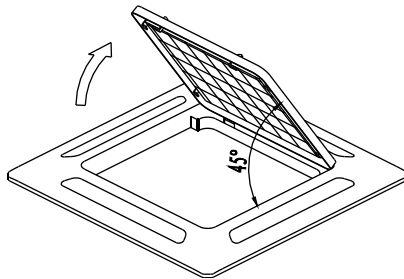

11.2.2 Install the panel

1. Align the indicate "△" on the decoration panel to the indicate "△" on the unit .

2. Attach the decoration panel to the unit with the supplied screws as shown in figure below.

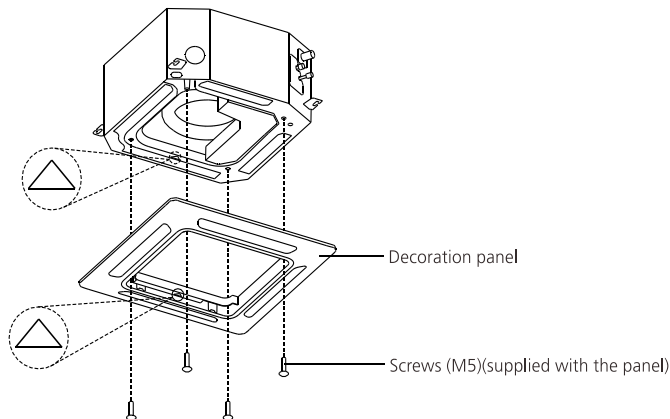

3. After installing the panel, ensure that there is no space between the unit body and decoration panel. Otherwise air may leak through the gap and cause dewdrop.

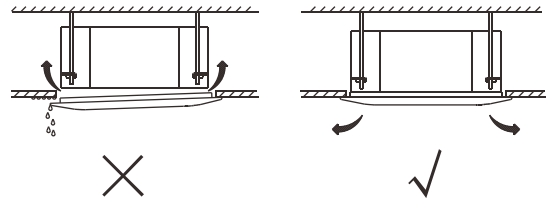

11.2.3 Mount the grille

Ensure that the buckles at the back of the grille be properly seated in the groove of the panel.

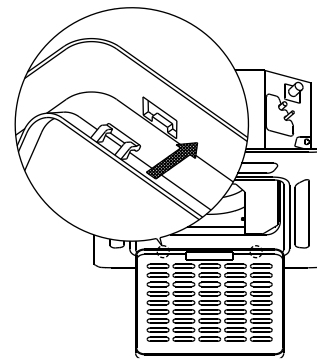

11.2.4 Connect the two wires of the panel to the main board of the unit.

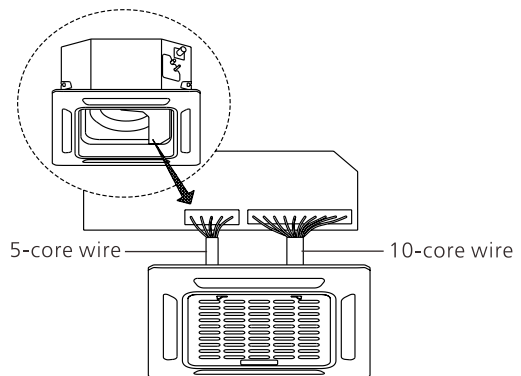

11.2.5 Fasten the control box lid with two screws .

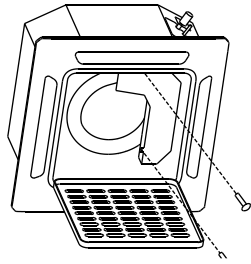

11.2.6 Close the front grille, and close the two grille hooks.

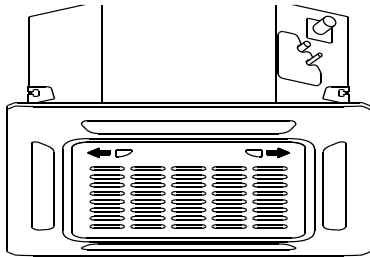

12. Test Operation

1. The test operation must be carried out after the entire installation has been completed.

2. Please confirm the following points before the test operation.

- The indoor unit and outdoor unit are installed properly.
- Piping and wiring are properly connected.
- Ensure that there are no obstacles near the inlet and outlet of the unit that might cause poor performance or product malfunction.
- The refrigeration system does not leak.
- The drainage system is unimpeded and draining to a safe location.
- The heating insulation is properly installed.
- The grounding wires are properly connected
- The length of the piping and the added refrigerant stow capacity have been recorded.
- The power voltage is the correct voltage for the air conditioner.

CAUTION: Failure to perform the test run may result in unit damage, property damage or personal injury.

3. Test Run Instructions

1. Open both the liquid and gas stop valves.
2. Turn on the main power switch and allow the unit to warm up.
3. Set the air conditioner to COOL mode, and check the

following points.

Indoor unit

- Whether the switch on the remote controller works well.
- Whether the buttons on the remote controller works well.
- Whether the air flow louver moves normally.
- Whether the room temperature is adjusted well.
- Whether the indicator lights normally.
- Whether the temporary buttons works well.
- Whether the drainage is normal.
- Whether there is vibration or abnormal noise during operation.

Outdoor unit

- Whether there is vibration or abnormal noise during operation.
- Whether the generated wind, noise, or condensed of by the air conditioner have influenced your neighborhood.
- Whether any of the refrigerant is leaked.

3. Drainage Test

- a. Ensure the drainpipe flow smoothly. New buildings should perform this test before finishing the ceiling.
- b. Remove the test cover. Add 2000ml of water to the tank through the attached tube.
- c. Turn on the main power switch and run the air conditioner in COOL mode.
- d. Listen to the sound of the drain pump to see if it makes any unusual noises.
- e. Check to see that the water is discharged. It may take up to one minute before the unit begins to drain depending on the drainpipe.
- f. Make sure that there are no leaks in any of the piping.
- g. Stop the air conditioner. Turn off the main power switch and reinstall the test cover.



CLIVET SPA

Via Camp Lonc 25, Z.I. Villapaiera - 32032 Feltre (BL) - Italy
Tel. + 39 0439 3131 - Fax + 39 0439 313300 - info@clivet.it

CLIVET GROUP UK Limited

4 Kingdom Close, Segensworth East - Fareham, Hampshire - PO15 5TJ - United Kingdom
Tel. + 44 (0) 1489 572238 - Fax + 44 (0) 1489 573033 - enquiries@clivetgroup.co.uk

CLIVET GROUP UK Limited (Operations)

Units F5&F6 Railway Triangle Ind Est, Walton Road - Portsmouth, Hampshire - PO6 1TG - United Kingdom
Tel. +44 (0) 2392 381235 - Fax. +44 (0) 2392 381243 - service@clivetgroup.co.uk

CLIVET ESPAÑA S.A.U.

C/ Bac de Roda, 36 - 08019 Barcelona - España
Tel: +34 93 8606248 - Fax +34 93 8855392 - info@clivet.es

Av.Manoteras Nº 38, Oficina C303 - 28050 Madrid - España
Tel. +34 91 6658280 - Fax +34 91 6657806 - info@clivet.es

CLIVET GmbH

Hummelsbütteler Steindamm 84, 22851 Norderstedt - Germany
Tel. + 49 (0) 40 32 59 57-0 - Fax + 49 (0) 40 32 59 57-194 - info.de@clivet.com

CLIVET RUSSIA

Elektrozavodskaya st. 24, office 509 - 107023, Moscow, Russia
Tel. + 74956462009 - Fax + 74956462009 - info.ru@clivet.com

CLIVET MIDEAST FZCO

Dubai Silicon Oasis (DSO), High Bay Complex, Office N. 20, PO BOX 342009, Dubai, UAE
Tel. + 9714 3208499 - Fax + 9714 3208216 - info@clivet.ae

CLIVET AIRCONDITIONING SYSTEMS PRIVATE LIMITED

501/502, Commercial-1, Kohinoor City, Old Premier Compound, Kirol Road, Off L B S Marg, Kurla West - Mumbai 400 070 - India
info.in@clivet.com

www.clivet.com
www.clivetlive.com