

WSAT-XSC3 90.4 - 240.4

Air cooled water chiller for outdoor installation



Dear Customer,

We congratulate you on choosing this product

For many years Clivet has been offering systems that provide maximum comfort, together with high reliability, efficiency, quality and safety.

The aim of the company is to offer advanced systems, that assure the best comfort, reduce energy consumption and the installation and maintenance cost for the life cycle of the system.

The purpose of this manual is to provide you with information that is useful from reception of the equipment, through installation, operational usage and finally disposal so that this advanced system offers the best solution.

Yours faithfully,

CLIVET Spa

The data contained in this manual is not binding and may be changed by the manufacturer without prior notice.

Reproduction, even in part, is FORBIDDEN © Copyright - CLIVET S.p.A. - Feltre (BL) - Italia

Index of contents

1	General description	4
2	Reception	6
3	Positioning	8
4	Water connections	10
5	Electrical connections	13
6	Start-up	19
7	Control	28
8	Maintenance	40
9	Accessories	46
10	Decommissioning	54
11	Residual risks	55
12	Technical information	56
13	Dimensional drawings	64

1 General description

1.1 Manual

The manual provides correct unit installation, use and maintenance.

Pay particular attention to:



Warning, identifies particularly important operations or information.



Prohibited operations that must not be carried out, that compromise the operating of the unit or may cause damage to persons or things.

- It is advisable to read it carefully so you will save time during operations.
- Follow the written indications so you will not cause damages to things and injuries people.

1.2 Preliminaries

Only qualified personnel can operate on the unit, as required by the regulation in force.

1.3 Risk situations



The unit has been designed and created to prevent injuries to people.

During designing it is not possible to plane and operate on all risk situation.

Read carefully "Residual risk" section where all situation which may cause damages to things and injuries to people are reported.

Installation, starting, maintenance and repair required specific knowledge; if they are carried out by inexperienced personnel, they may cause damages to things and injuries people.

1.4 Intended use

Use the unit only:

- for cooling/heating water or a water and glycol mix
- keep to the limits foreseen in the technical schedule and in this manual

The manufacturer accepts no responsibility if the equipment is used for any purpose other than the intended use.

1.5 Installation

Outdoor installation



The positioning, hydraulic system, refrigerating, electrics and the ducting of the air must be determined by the system designer in accordance with local regulations in force.

Follow local safety regulations.

Verify that the electrical line characteristics are in compliance with data quotes on the unit serial number label.

1.6 Maintenance

Plan periodic inspection and maintenance in order to avoid or reduce repairing costs.



Turn the unit off before any operation.

1.7 Modification



All unit modifications will end the warranty coverage and the manufacturer responsibility.

1.8 Breakdown/Malfuction

Disable the unit immediately in case of breakdown or malfunction.

Contact a certified service agent.

Use original spares parts only.

Using the unit in case of breakdown or malfunction:

- voids the warranty
- it may compromise the safety of the unit
- may increase time and repair costs

1.9 User training



The installer has to train the user on:

- Start-up/shutdown
- Set points change
- Standby mode
- Maintenance
- What to do / what not to do in case of breakdown

1.10 Data update

Continual product improvements may imply manual data changes.

Visit manufacturer web site for updated data.

1.11 Indications for the User



Keep this manual with the wiring diagram in an accessible place for the operator.

Note the unit data label so you can provide them to the assistance centre in case of intervention (see “Unit identification” section).

Provide a unit notebook that allows any interventions carried out on the unit to be noted and tracked making it easier to suitably note the various interventions and aids the search for any breakdowns.

In case of breakdown or malfunction:

- Immediately deactivate the unit
- Contact a service centre authorized by the manufacturer



The installer must train the user, particularly on:

- Start-up/shutdown
- Set points change
- Standby mode
- Maintenance
- What to do / what not to do in case of breakdown

1.12 Unit identification

The serial number label is positioned on the unit and allows to identify all the unit features.

The matriculation plate shows the indications foreseen by the standards, in particular:

- unit type
- serial number (12 characters)
- year of manufacture
- wiring diagram number
- electrical data
- type of refrigerant
- refrigerant charge
- manufacturer logo and address



The matriculation plate must never be removed.



It contains fluorinated greenhouse gases

Type of refrigerant: R410A

1.13 Serial number

It identifies uniquely each unit.

Must be quoted when ordering spare parts.

1.14 Assistance request

Note data from the serial number label and write them in the chart on side, so you will find them easily when needed.

Series
Size
Serial number
Year of manufacture
Electrical wiring diagram

2 Reception



You have to check before accepting the delivery:

- That the unit hasn't been damaged during transport
- That the materials delivered correspond with that indicated on the transport document comparing the data with the identification label positioned on the packaging.

In case of damage or anomaly:

- Write down on the transport document the damage you found and quote this sentence: "Conditional acceptance clear evidence of deficiencies/damages during transport"
- Contact by fax and registered mail with advice of receipt to supplier and the carrier.



Any disputes must be made within 8 days from the date of the delivery. Complaints after this period are invalid.

2.1 Storage

Observe external packaging instructions.

2.2 Handling

1. Verify unit weight and handling equipment lifting capacity.
2. Identify critical points during handling (disconnected routes, flights, steps, doors).
3. Suitably protect the unit to prevent damage.
4. lifting brackets
5. Lifting with balance
6. Lifting with spacer bar
7. Align the barycenter to the lifting point
8. Use all the lifting brackets (see the dimensional section)
9. Gradually bring the lifting belts under tension, making sure they are positioned correctly.
10. Before starting the handling, make sure that the unit is stable.

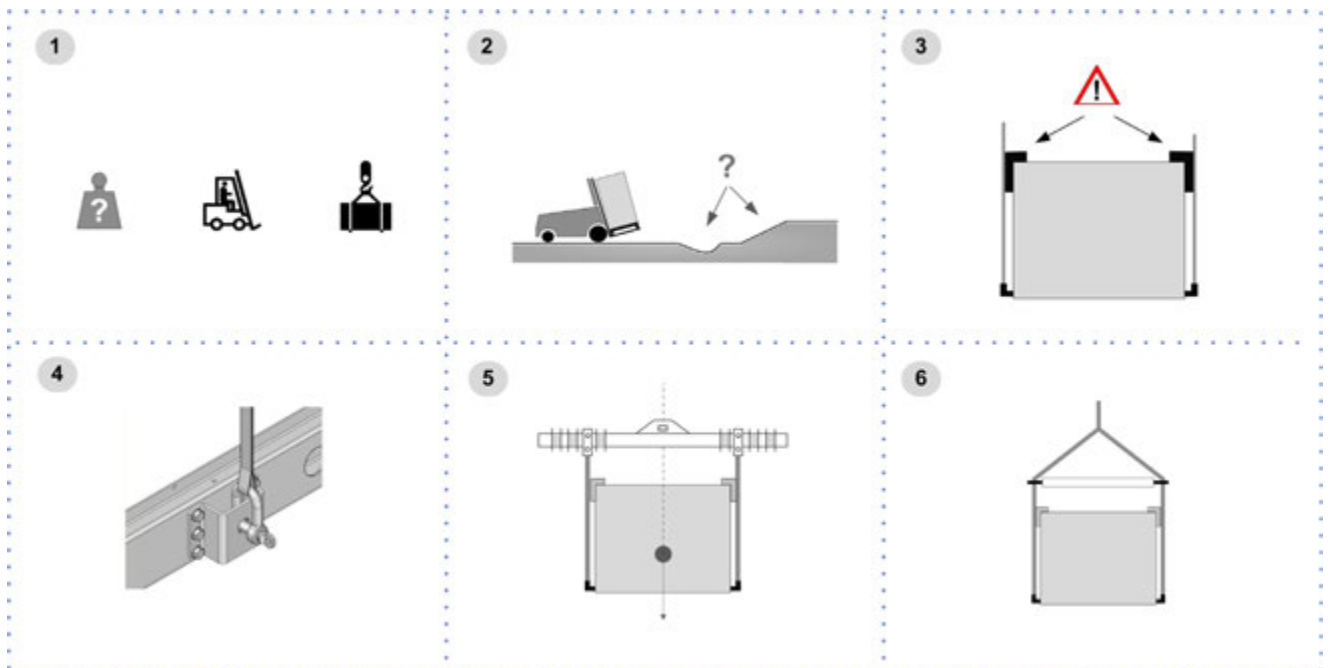

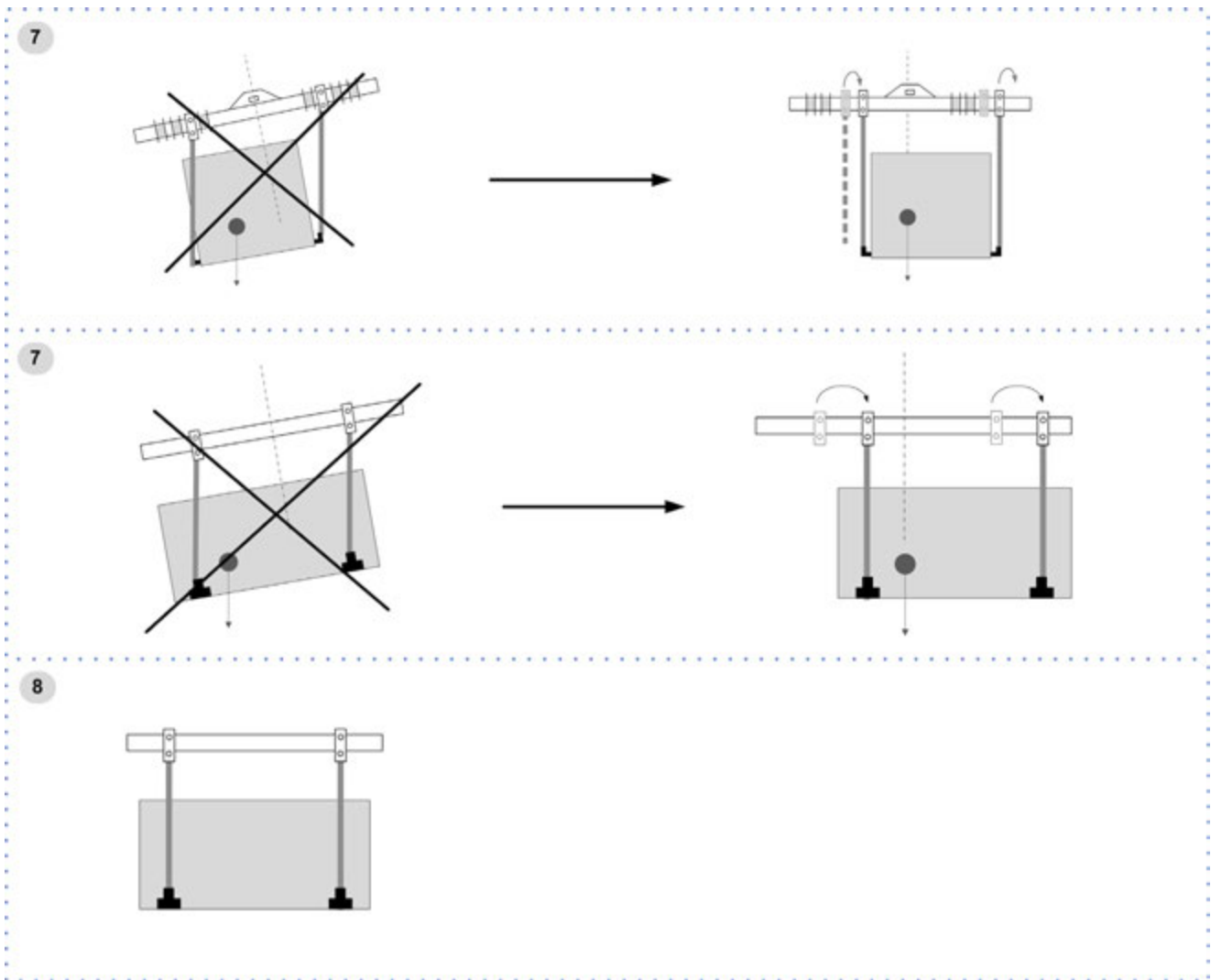

2.3 Packaging removing

Be careful not to damage the unit.

Keep packing material out of children's reach it may be dangerous.

Recycle and dispose of the packaging material in conformity with local regulations.



- A Supports for handling: remove after the handling.
- B Remove the coil protective mesh before the start-up

3 Positioning

During positioning consider these elements:

- Technical spaces requested by the unit
- Electrical connections
- Water connections
- Spaces for air exhaust and intake

3.1 Functional spaces

Functional spaces are designed to:

- guarantee good unit operation
- carry out maintenance operations
- protect authorized operators and exposed people

Respect all functional spaces indicated in the DIMENSIONS section.

Double all functional spaces if two or more unit are aligned.

3.2 Positioning



Units are designed to be installed:

- EXTERNAL
- in fixed positions

Limit vibration transmission:

- use anti-vibration devices or neoprene strips on the unit support points
- install flexible joints on the hydraulic connections
- install flexible joints on the hydraulic connections

Choose the installation place according to the following criteria:

- Customer approval
- safe accessible position
- technical spaces requested by the unit
- spaces for the air intake/exhaust
- max. distance allowed by the electrical connections
- install the unit raised from the ground
- verify unit weight and bearing point capacity
- verify that all bearing points are aligned and leveled
- condensate water draining
- consider the maximum possible snow level
- Avoid installations in places subject to flooding

Protect the unit with suitable fence in order to avoid access to unauthorised personnel (children, vandals, etc.)

A correct circulation of the air is mandatory to guarantee the good unit operating.



Avoid therefore:

- obstacles to the airflow
- difficulty of exchange
- leaves or other foreign bodies that can obstruct the air coil
- winds that hinder or favour the airflow
- heat or pollution sources close to the unit (chimneys, extractors etc..)
- stratification (cold air that stagnates at the bottom)
- recirculation (expelled air that is sucked in again)
- incorrect positioning, close to very high walls, attics or in angles that could give rise to stratification or recirculation phenomenons

Ignoring the previous indications could:

- reduce energy efficiency
- alarm lockout due to HIGH PRESSURE (in summer) or LOW PRESSURE (in winter)

3.3 Safety valve gas side

The installer is responsible for evaluating the opportunity of installing drain tubes, in conformity with the local regulations in force (EN 378).

3.4 AxiTop

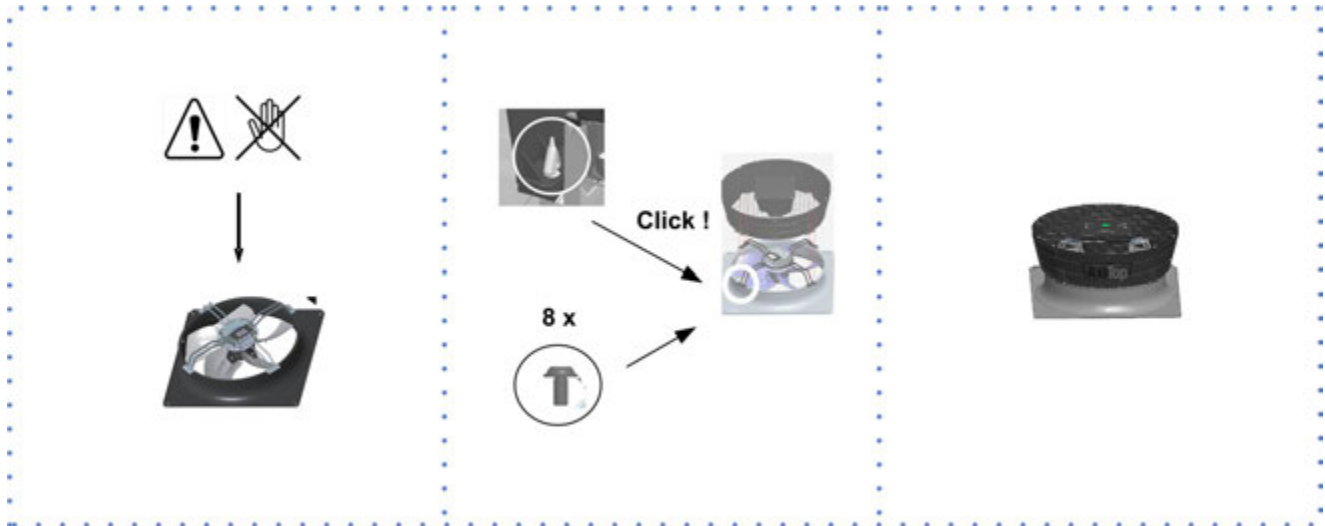

3.5 Anti-vibration mount support

For details see:
9 Accessories p. 46

4 Water connections

4.1 Water quality

Water features

- confirming to local regulations
- total hardness < 14°fr
- within the limits indicated by table

The water quality must be checked by qualified personnel.

Water with inadequate characteristics can cause:

- pressure drop increase
- reduces energy efficiency
- increased corrosion potential

Acceptable water quality values:

PH	7,5 ÷ 9,0	
SO ₄ ²⁻	< 100	ppm
HCO ₃ ⁻ /SO ₄ ²⁻	> 1	
Total Hardness	4,5 ÷ 8,5	dH
Cl ⁻	< 50	ppm
PO ₄ ³⁻	< 2,0	ppm
NH ₃	< 0,5	ppm

Free Chlorine	< 0,5	ppm
Fe ₃ ⁺	< 0,5	ppm
Mn ⁺⁺	< 0,05	ppm
CO ₂	< 50	ppm
H ₂ S	< 50	ppb
Temperature	< 65	°C
Oxygen content	< 0,1	ppm

Provide a water treatment system if values fall outside the limits.



The warranty does not cover damages caused by limestone formations, deposits and impurities from the water supply and / or failure from failed system clearing to clean system.

4.2 Risk of freezing

If the unit or the relative water connections are subject to temperatures close to 0°C:

- mix water with glycol, or
- safeguard the pipes with heating cables placed under the insulation, or
- empty the system in cases of long non-use

4.3 Anti-freeze solution

The use of an anti-freeze solution results in an increase in pressure drop.



Make sure that the glycol type utilized is inhibited (not corrosive) and compatible with the water circuit components.



Do not use different glycol mixture (i.e. ethylene with propylene).

4.4 Water flow-rate

The project water-flow must be:

- inside the exchanger operating limits (see the TECHNICAL INFORMATION section)
- guarantee, also with variable system conditions (for example in systems where some circuits are bypassed in particular situations).

For details see: Technical Bulletin, "Considerations on the installation" section

4.5 Minimum system water content

Minimum system water volumes are described within 'General technical data' section and they have to be satisfied to avoid continuous compressor switching on and off.

4.6 Recommended connection

- ⚠ The installer must define:
- component type
 - position in system

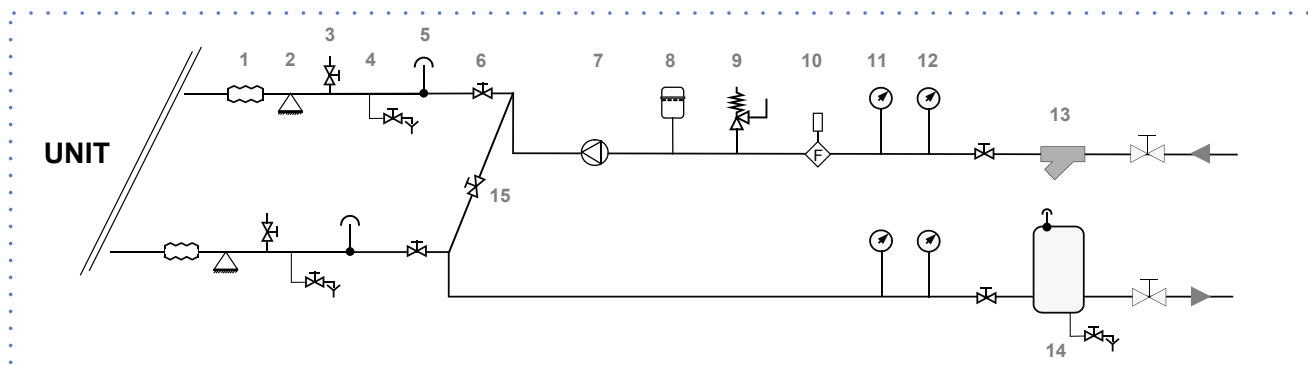

- | | | | |
|---|------------------------------------|----|------------------------|
| 1 | antivibration joints | 9 | safety valve |
| 2 | piping support | 10 | Flow Switch |
| 3 | exchanger chemical cleaning bypass | 11 | pressure gauge |
| 4 | drain valve | 12 | thermometer |
| 5 | vent | 13 | filter |
| 6 | shut-off valve | 14 | Internal storage tank |
| 7 | Pump / circulating pump | 15 | Cleaning system bypass |
| 8 | expansion vessel | | |

4.7 Hydraulic connections

- take away the supplied connection union by acting on the connection joint
- weld the union to the installation pipe
- perform the connection between the installation pipe and the evaporator, using the joint

⊘ Do not weld the system pipe with the Victaulic connection joint attached.

⚠ The rubber gasket might be irreparably damaged.

4.8 Water filter

Use filter with mesh pitch:

1,6 mm

⚠ It must be installed immediately in the water input of the unit, in a position that is easily accessible for cleaning.

⊘ The filter never should be removed, this operation invalidates the guaranty.

4.9 Flow Switch

- ⚠ The flow switch must be present to ensure shutdown of the unit if water is not circulating. It has to be installed in a duct rectilinear part, not in proximity of curves that cause turbulences. Electrically connect the flow switch at the inlet arranged on the XC terminal block. The flow switch must be set to the minimum reachable flow rate.

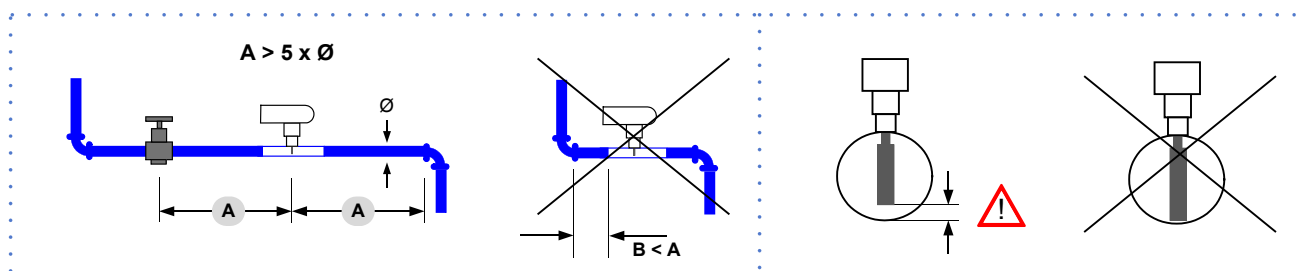

A. minimum distance

4.10 Operation sequence

Close all vent valves in the high points of the unit hydraulic circuit

Close all drain valves in the low points of the unit hydraulic circuit:

- Heat exchangers
 - Pumps
 - collectors
 - storage tank
 - free-cooling coil
1. Carefully wash the system with clean water: fill and drain the system several times.
 2. Apply additives to prevent corrosion, fouling, formation of mud and algae.
 3. Fill the plant
 4. Execute leakage test.
 5. Isolate the pipes to avoid heat dispersions and formation of condensate.
 6. Leave various point of service free (wells, vent-holes etc).



Neglecting the washing will lead to several filter cleaning interventions and at worst cases can cause damages to the exchangers and the other parts.

4.11 hydronic assembly

For details see:

9 Accessories p. 46

4.12 Energy recovery

For details see:

9 Accessories p. 46

5 Electrical connections

The characteristics of the electrical lines must be determined by qualified electrical personnel able to design electrical installations; moreover, the lines must be in conformity with regulations in force.

The protection devices of the unit power line must be able to stop all short circuit current, the value must be determined in accordance with system features.

The power cables and the protection cable section must be defined in accordance with the characteristics of the protections adopted.

All electrical operations should be performed by trained personnel having the necessary qualifications required by the regulations in force and being informed about the risks relevant to these activities.

Operate in compliance with safety regulations in force.

5.1 Electrical data



The serial number label reports the unit specific electrical data, included any electrical accessories.

The electrical data indicated in the technical bulletin and in the manual refer to the standard unit, accessories excluded.

The matriculation plate shows the indications foreseen by the standards, in particular:

- Voltage
- F.L.A.: full load ampere, absorbed current at maximum admitted conditions
- F.L.I.: full load input, full load power input at max. admissible condition
- Electrical wiring diagram Nr.

5.2 Connections

1. Refer to the unit electrical diagram (the number of the diagram is shown on the serial number label).
2. Verify that the electrical supply has characteristics conforming to the data shown on the serial number label.
3. Before starting work, ensure the unit is isolated, unable to be turned on and a safety sign used.
4. Ensure correct earth connection.
5. Ensure cables are suitably protected.
6. Before powering up the unit, make sure that all the protections that were removed during the electrical connection work have been restored.

5.3 Signals / data lines

Do not exceed the maximum power allowed, which varies, according to the type of signal.

Lay the cables far from power cables or cables having a different tension and that are able to emit electromagnetic disturbances.

Do not lay the cable near devices which can generate electromagnetic interferences.

Do not lay the cables parallel to other cables, cable crossings are possible, only if laid at 90°.

Connect the screen to the ground, only if there aren't disturbances.

Guarantee the continuity of the screen during the entire extension of the cable.

Respect inductance, capacity and attenuation indications.

5.4 Power input



Fix the cables: if vacated may be subject to tearing.



The cable must not touch the compressor and the refrigerant piping (they reach high temperatures).

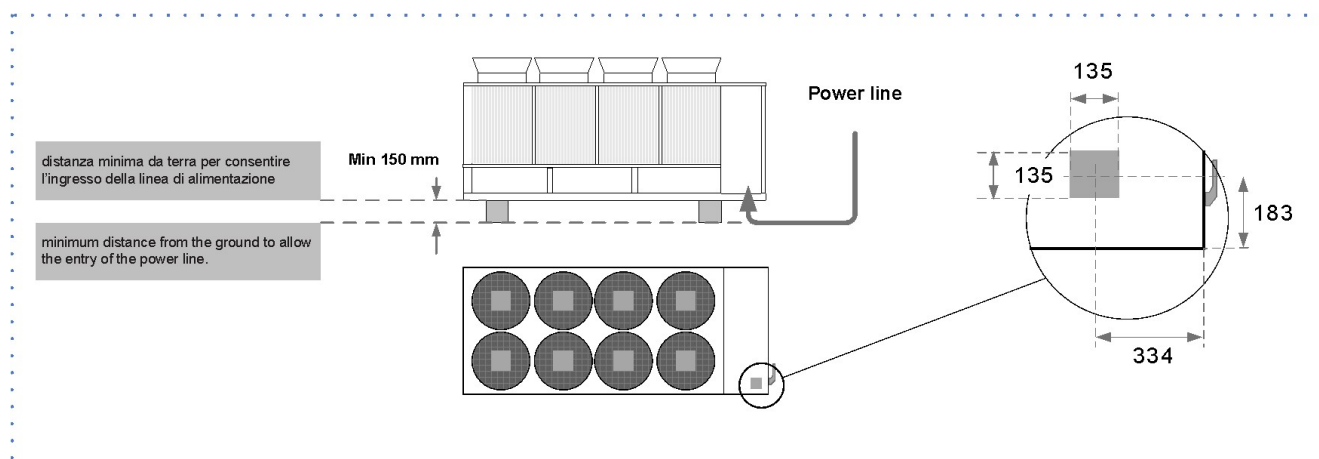

5.5 Power supply cables section

Size	90.4	100.4	110.4	120.4	140.4	160.4	180.4
Min. cable section Cu (mm ²)	1x95	1x95	1x150	1x150	1x150	1x240	1x240
Max. cable section Cu (mm ²)	1x185	1x185	1x240	1x240	1x240	1x240	1x240
Min. bar Cu section (mm ²)	-	-	-	-	-	-	-
Max. bar Cu width (mm)	32	32	32	32	32	40	40
Tightening torque (Nm)	20	20	20	20	20	20	20

Size	200.4	220.4	240.4				
Min. cable section Cu (mm ²)	2x150	2x150	2x150				
Max. cable section Cu (mm ²)	2x300	2x300	2x300				
Min. bar Cu section (mm ²)	2 x 30 x 5	2 x 30 x 5	2 x 30 x 5				
Max. bar Cu width (mm)	50	50	50				
Tightening torque (Nm)	20	20	20				

5.6 Connections performed by customer

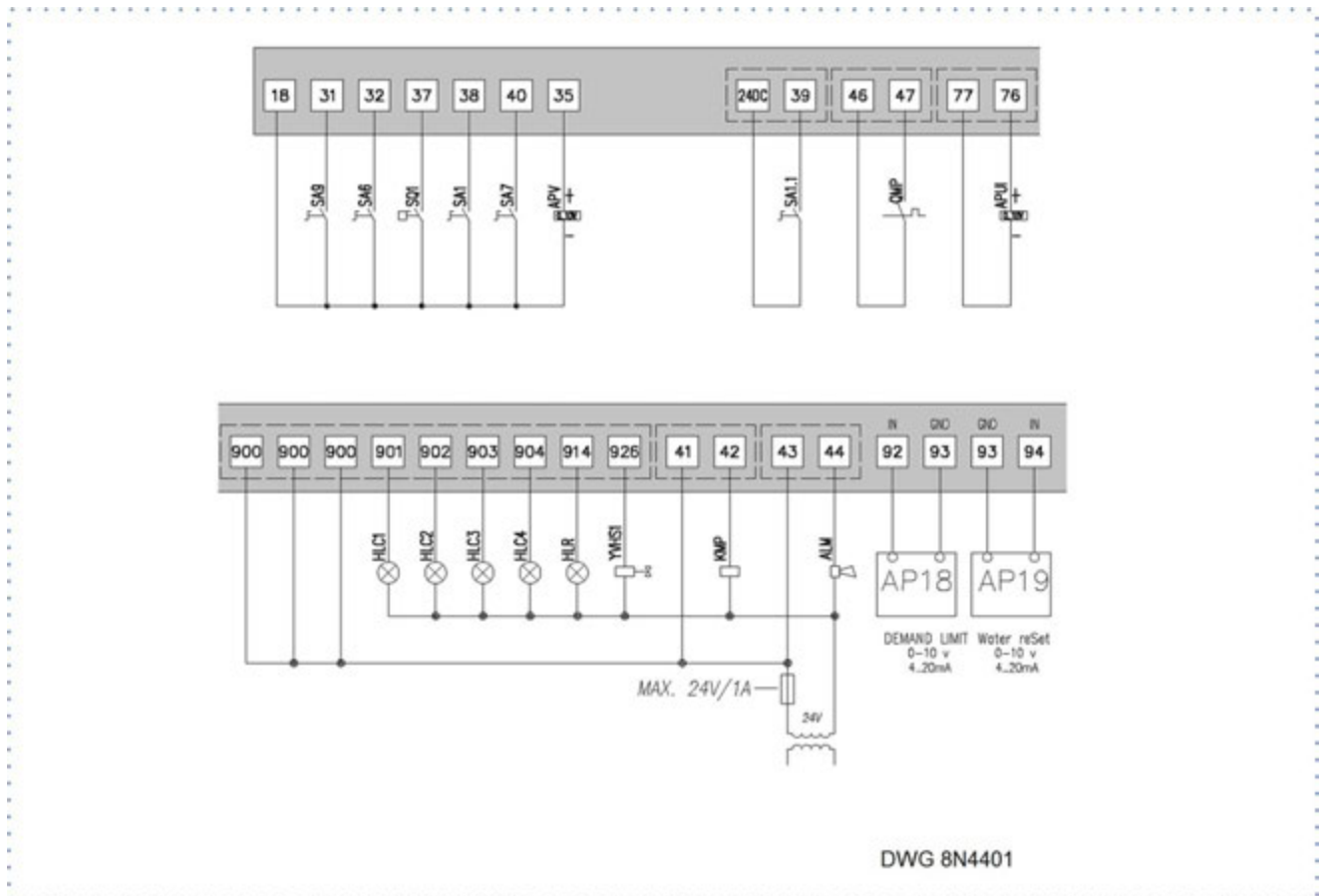

ALM	cumulative fault signal	QMP	pump protection automatic device
AP18	demand limit	SA1	remote on-off
AP19	water reset	SA1.1	second setpoint enabling switch
APUI	inverter user side	SA6	sanitary hot water cycle switch
APV	0..10V analogical output for free-cooling management	SA7	summer-winter switch
HLC1-4	compressor status signal lamp	SA9	cooling thermostat
HLR	alarm signal lamp electrical heater electrical panel selector	SQ1	Flow Switch
KMP	evaporator pump contactor	YVHS1	sanitary hot water valve

5.7 Remote ON-OFF

- ⊘ Do not perform short On Off cycles
- ⊘ Do not use the remote On Off with thermoregulation function.

5.8 Remote control

Option

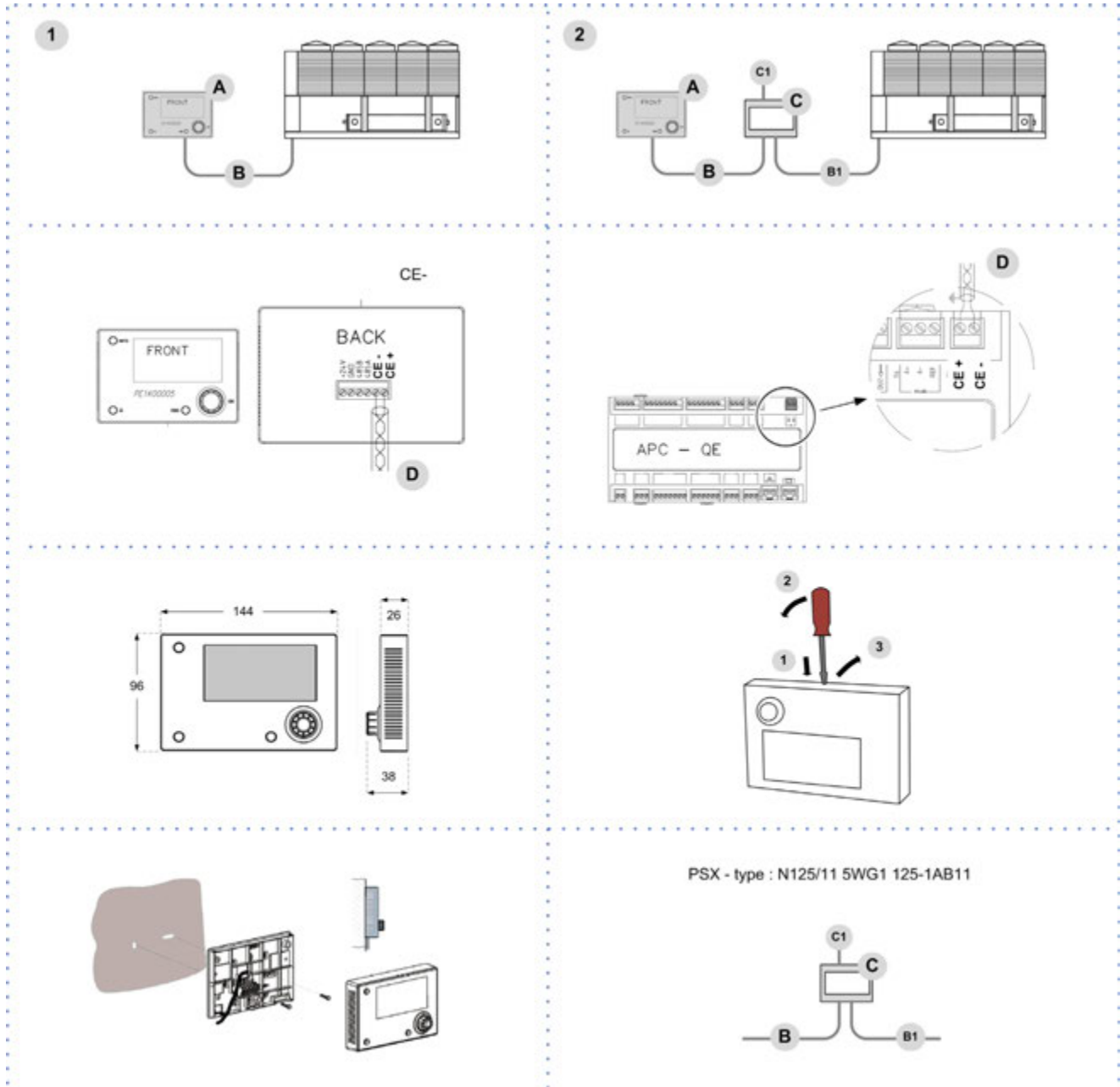

- 1 Distance up to 350 mt
- 2 Distance up to 700 mt

- A User interface
- B = B1 KNX bus, max 350 mt
twisted pair with shield, \varnothing 0,8 mm
EIB/KNX cable marking recommende
- C PSX - Mains power supply unit
pwer supply unit N125/11 5WG1 125-1AB11
- C1 AC 120...230V, 50...60Hz
- D KNX bus, max 350 mt

5.9 Computer connection

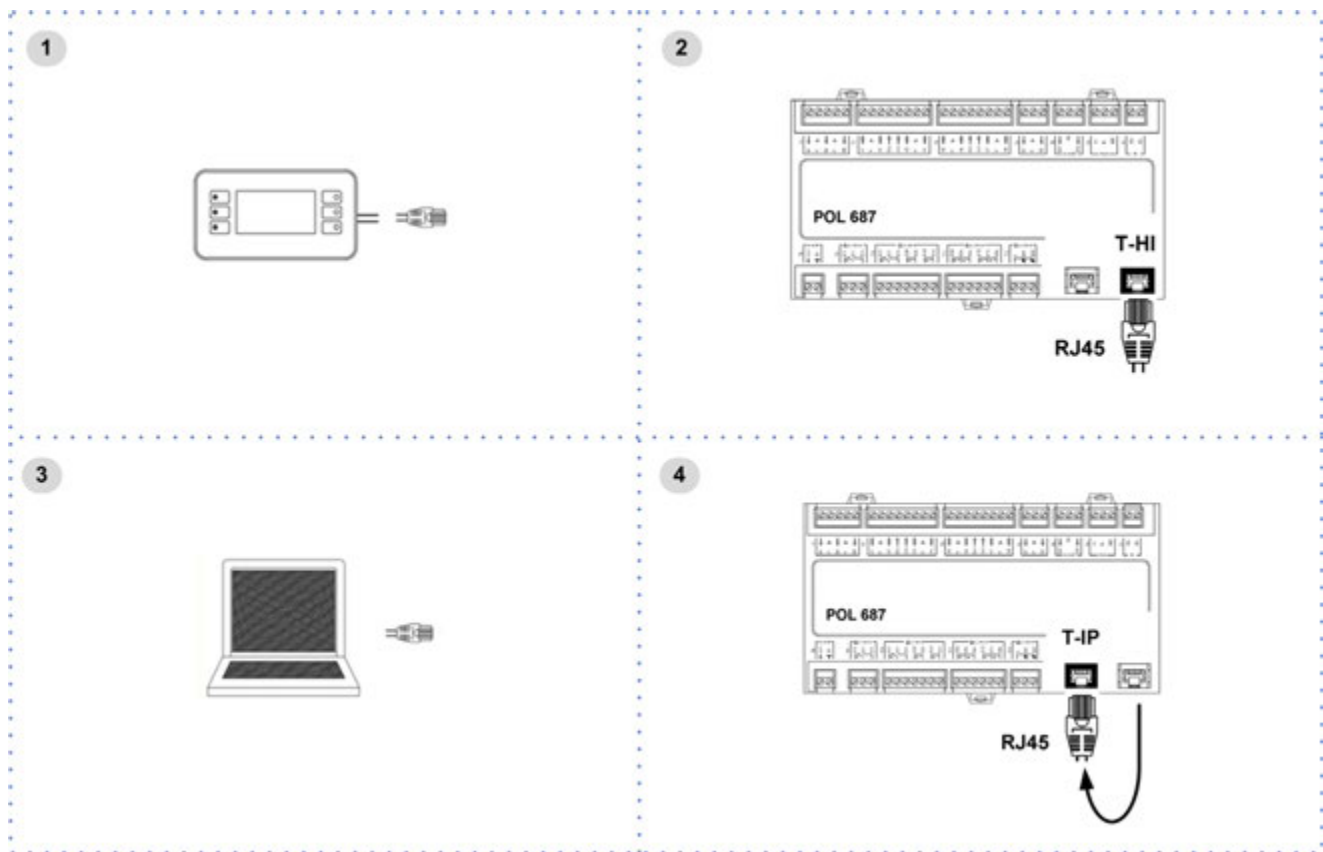

1. Service keypad
2. RJ45: standard connection
3. P.C.-not supplied
4. P.C. connection, shift RJ45 from T-HI to T-IP

Configure P.C.

1. connect P.C. and main module with LAN cable
2. check in the taskbar that the connection is active
3. open Control Panel and select Network and sharing center
4. select Modify board setting
5. select Local area connection (LAN)
6. select Internet protocol version 4 (TCP) IPV4 and enter Property
7. set the IP address 192.168.1.100
8. set Subnet mask as 255.255.255.0
9. confirm (OK)
10. enter Start (Windows button)
11. write the command cmd and enter/do it
12. write and run the command Ping 192.168.1.42
13. the message, connection is OK, will appear when successful
14. enter the browser (Chrome, Firefox ecc)
15. write and run the command http://192.168.1.42
16. Userid = WEB
17. Password = SBTAdmin!

5.10 Modbus - RS485

Option

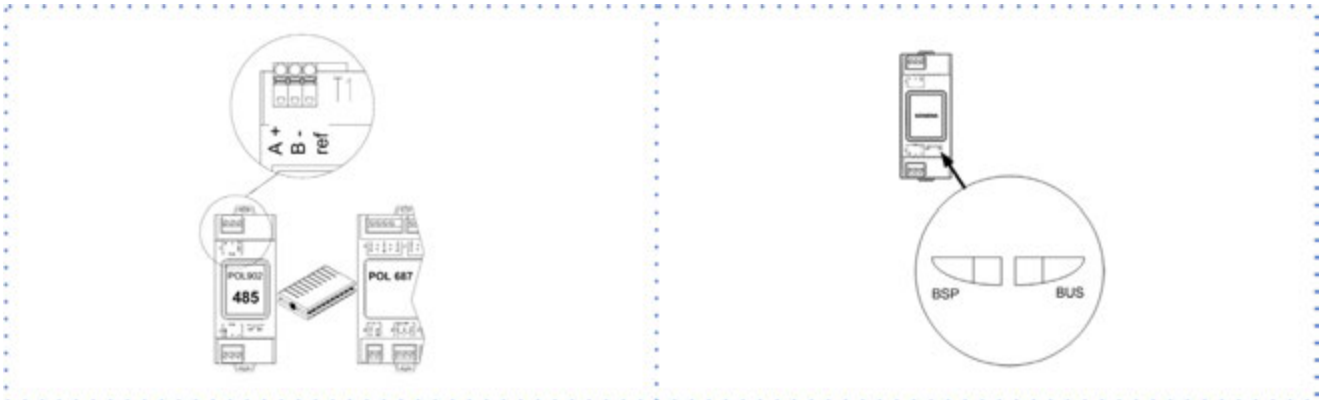

LED BSP
green communication with AP1 module
yellow communication ok
red flashing: software error
fixed: hardware error

LED BUS
green communication ok
yellow startup / channel not communicating
red communication down

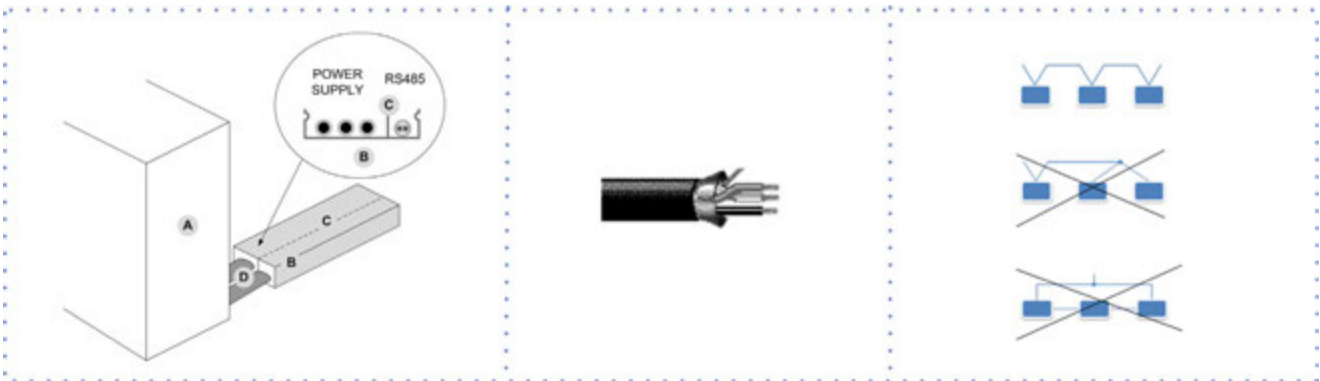

- A. Unit
- B. Metal conduit
- C. Metal septums
- D. Metal-lined sheath (sleeve)

Modbus / LonWorks / Cable requirements

Couple of conductors twisted and shielded

Section of conductor 0,22mm²...0,35mm²

Rated power between conductors $\leq 50 \text{ pF/m}$

Nominal impedance 120 Ω

Recommended cable BELDEN 3106A

- Every RS485 serial line must be set up using the 'In/Out' bus system.
- Other types of networks are not allowed, such as Star or Ring networks.
- The difference in potential between the earth of the two RS485 devices that the cable shielding needs to be connected to must be lower than 7 V
- There must be suitable arresters to protect the serial lines from the effects of atmospheric discharges
- A 120 ohm resistance must be located on the end of the serial line. Alternatively, when the last serial board is equipped with an internal terminator, it must be enabled using the specific jumper, dip switch or link.
- The cable must have insulation features and non-flame propagation in accordance with applicable regulations.
- The RS485 serial line must be kept as far away as possible from sources of electromagnetic interference.

5.11 LonWorks

Option

LonWorks

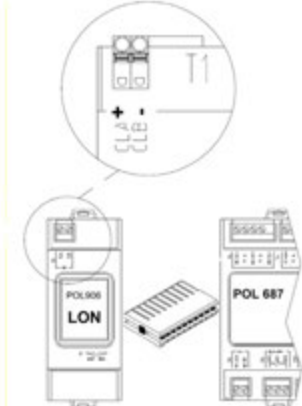

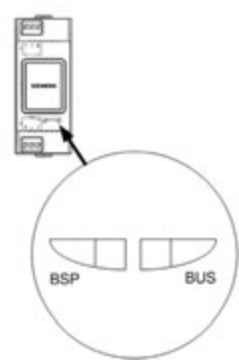

LONWORK CABLE TYPE
Echelon allows three cable types for channel type TP/FT-10, including the Category 5 network cable used commonly in building automation and control (TIA 568A Cat-5).

CAT-5 SPECIFICATIONS
Unshielded cable, twisted pair with at least 18 beats per meter:

- Cross-sectional area Min. \varnothing 0.5mm, AWG24, 0.22mm²
- Impedance 100 +/- 15% @ f > 1 MHz
- Operating capacity between two wires of a pair < 46 nF/km
- Capacity pair to ground, asymmetric. < 3.3 nF/km
- DC loop resistance < 168 Ω

LED BSP	communication with AP1 module
green	communication ok
yellow	software ok but communication with AP1 down
red	flashing: software error
	fixed: hardware error

LED BUS	communication with LonWorks
green	ready for communication
yellow	startup
red	flashing: communicating not possible
	communication down

5.12 BACnet IP

Option

BACnet

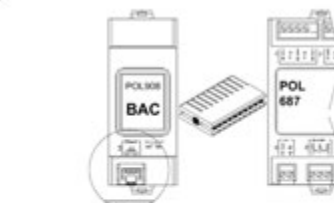

Ethernet 10/100 Mbit (IEEE 802.3U)
Cable connection RJ45 jack, 8 pins



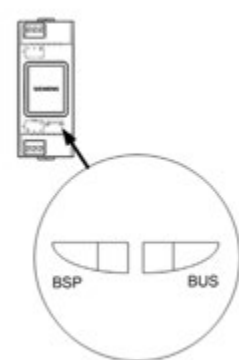

LED BSP	communication with AP1 module
green	communication ok
yellow	software ok but communication with AP1 down
red	flashing: software error
	fixed: hardware error

LED BUS	communication with BACnet
green	ready for communication
yellow	startup
red	BACnet server down
	restart after 3 sec

6 Start-up

6.1 General description

The indicated operations should be done by qualified technician with specific training on the product.

The electrical, water connections and the other system works are by the installer.

Upon request, the service centres performing the start-up.

Agree upon in advance the start-up data with the service centre.

For details refer to the different manual sections.

Before checking, please verify the following:

- the unit should be installed properly and in conformity with this manual
- the electrical power supply line should be isolated at the beginning
- the unit isolator is open, locked and equipped with the suitable warning
- make sure no tension is present



After turning off the power, wait at least 5 minutes before accessing to the electrical panel or any other electrical component.



Before accessing check with a multimeter that there are no residual stresses.

6.2 Preliminary checks

Unit OFF power supply

1. safety access
2. Axitop installed, if provided
3. functional spaces
4. air flow: correct return and supply (no bypass, no stratification)
5. structure integrity
6. fans run freely
7. unit on vibration isolators
8. unit input water filter + shut-off valves for cleaning
9. vibration isolators on water connections
10. Minimum system water content
11. expansion tank (indicative volume = 5% system content)
12. cleaned system
13. loaded system + possible glycol solution + corrosion inhibitor
14. system under pressure
15. vented system
16. refrigerant circuit visual check
17. earthing connection
18. power supply features
19. electrical connections provided by the customer

6.3 Start-up sequence

Unit ON power supply

1. compressor crankcase heaters operating at least since 8 hours
2. off-load voltage measure
3. phase sequence check
4. pump manual start-up and flow check
5. shut-off valve refrigerant circuit open
6. unit ON
7. load voltage measure and absorptions
8. liquid sight glass check (no bubbles)
9. check all fan operating
10. measure return and supply water temperature
11. measure super-heating and sub-cooling
12. check no anomalous vibrations are present
13. climatic curve personalization
14. climatic curve personalization
15. scheduling personalization
16. complete and available unit documentation

6.4 Refrigeration circuit

1. Check carefully the refrigerating circuit: the presence of oil stains can mean leakage caused by transportation, movements or other).
2. Verify that the refrigerating circuit is in pressure: Using the unit manometers, if present, or service manometers.
3. Make sure that all the service outlets are closed with proper caps; if caps are not present a leak of refrigerant can be possible.
4. Open the valves of the refrigerant circuit, if there are any.

6.5 Water circuit

1. Before realizing the unit connection make sure that the hydraulic system has been cleaned up and the cleaning water has been drained.
2. Check that the water circuit has been filled and pressurized.
3. Check that the shut-off valves in the circuit are in the "OPEN" position.
4. Check that there isn't air in the circuit, if required, evacuate it using the air bleed valve placed in the system high points.
5. When using antifreeze solutions, make sure the glycol percentage is suitable for the type of use envisaged.



Neglecting the washing will lead to several filter cleaning interventions and at worst cases can cause damages to the exchangers and the other parts.

Weight of glycol (%)	10	20	30	40
Freezing temperature (°C)	-3.9	-8.9	-15.6	-23.4
Safety temperature (°C)	+1	-4	-10	-19

6.6 Electric Circuit



Verify that the unit is connected to the ground plant.

Check the conductors are tightened as: the vibrations caused by handling and transport might cause these to come loose.

Connect the unit by closing the sectioning device, but leave it on OFF.

Check the voltage and line frequency values which must be within the limits: 400/3/50 +/- 10%

Check and adjust the phase balance as necessary: it must be lower than 2%

Example

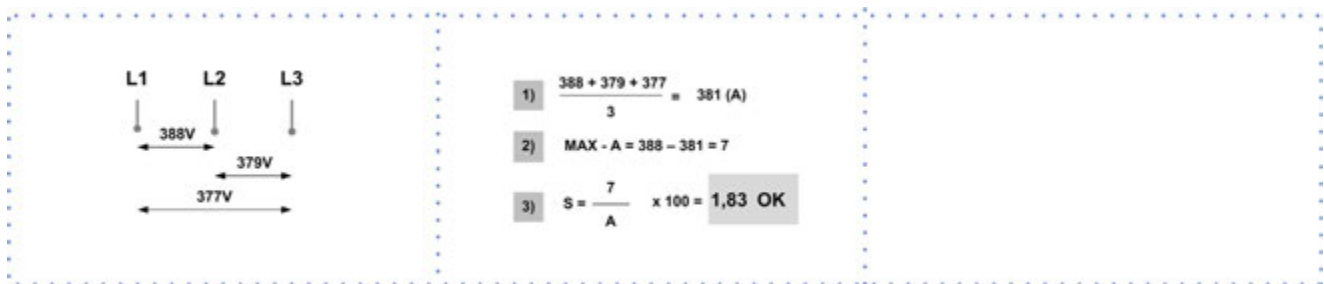

Working outside of these limits can cause irreversible damages and voids the warranty.

6.7 Compressor crankcase heaters

Connect the oil resistances on the compressor crankcase at least 8 hours before the compressor is to be started:

- at the first unit start-up
 - after each prolonged period of inactivity
1. Supply the resistances switching off the unit isolator switch.
 2. To make sure that heaters are working, check the power input.
 3. At start-up the compressor crank-case temperature on the lower side must be higher at least of 10°C than the outside temperature.



Do not start the compressor with the crankcase oil below operating temperature.

6.8 Remote controls

Check that the remote controls (ON-OFF etc) are connected and, if necessary, enabled with the respective parameters as indicated in the "electrical connections" section.

Check that probes and optional components are connected and enabled with the respective parameters ("electrical connections" section and following pages).

6.9 Voltages

Check that the air and water temperatures are within in the operating limits.

Start-up the unit.

With unit operating in stable conditions, check:

- Voltage
- Total absorption of the unit
- Absorption of the single electric loads

6.10 Demand limit

⚠ Menu accessible only after having entered the password.

⚠ Access reserved only to specifically trained personnel.

⚠ The parameter modification can cause irreversible damages.

It is possible to limit the absorbed electric power with an external signal 0-10 Vcc.

The higher the signal is, the lower the number of compressors available to meet the thermal need.

If only P0002: EnDemandLimit \neq 0

Path: Main Menu / Unit parameters / Demand limit

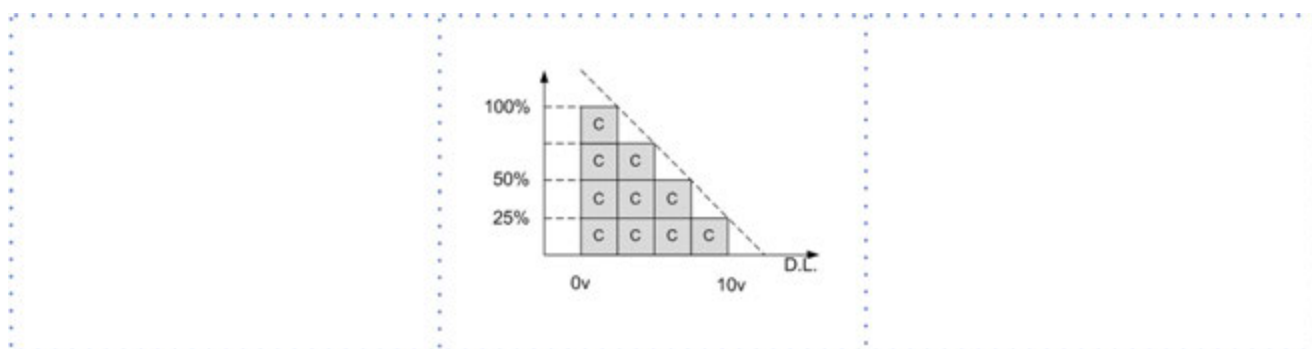

Step	Display	Action	Menu/Variable	Keys		Notes
1		Press 3 sec.		✓		
2	Password	Set	Password	▲	✓	
3		Press		i		
4	Main menu	Select	Unit parameters	▼	✓	
5	Unit parameters	Select	Set Point	▼	✓	
6	Set Point	Select	Demand limit	▼	✓	
7		Set	Demand limit	▲	▼	
8		Confirm		✓		
9		Press 3 sec.		⏏		
10		Select	Local connections	✓		

Path: Main Menu / Unit parameters / Demand limit

Parameters	Short description	Description
P0200	setpointdemandlimit	Parameter setting of the value % of demand limit

6.11 Climatic TExt

- ⚠ Menu accessible only after having entered the password.
 - ⚠ Access reserved only to specifically trained personnel.
 - ⚠ The parameter modification can cause irreversible damages.
- The setpoint defined by the temperature curve is shown at status S0052: ActualUtSetp
 Only if P0036: EnCompExt ≠ 0
 Path: Main Menu / Unit parameters / TExt Correction config
 Example

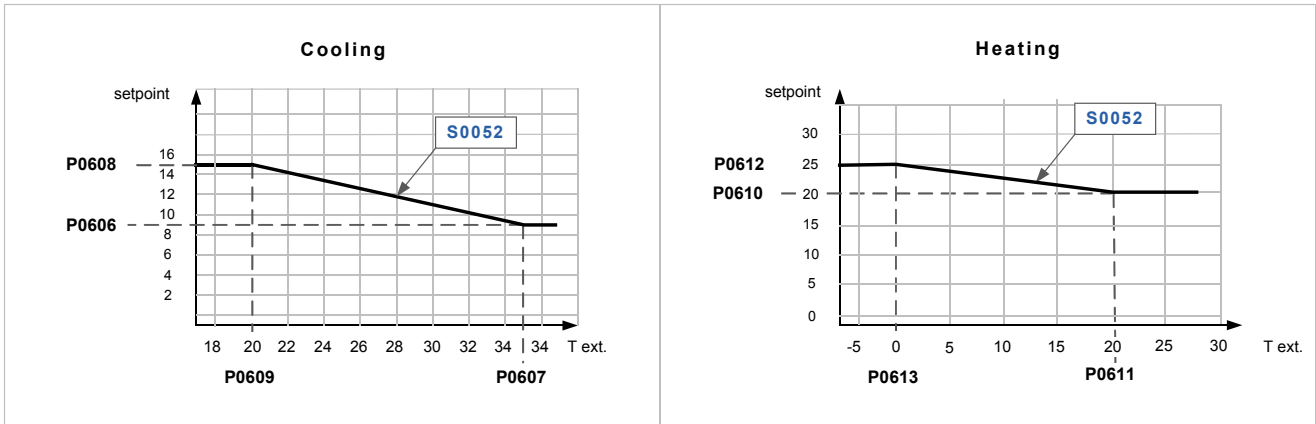

Step	Display	Action	Menu/Variable	Keys		Notes
1		Press 3 sec.		✓		
2	Password	Set	Password	▲	✓	
3		Press		i		
4	Main menu	Select	Unit parameters	▼	✓	
5	Unit parameters	Select	Climatic TExt	▼	✓	
6	Climatic TExt (pwd)	Select	Parameter	▼	✓	
7		Set		▼	▲	
8		Confirm		✓		
9		Press 3 sec.		⏏		
10		Select	Local connections	▼	✓	

Path: Main Menu / Unit parameters / TExt Correction config

Parameters	Short description	Description
P0606	CSptLow	setpoint temperature value when the air temperature value is AirAtSptLowC
P0607	AirAtSetPointLowC	external air temperature value where the calculated setpoint takes on the value given by CSptLow
P0608	CSptHigh	setpoint temperature value when the air temperature value is AirAtSptHigC
P0609	AirAtSetPointHighC	external air temperature value where the calculated setpoint takes on the value given by CSptHigh
P0610	HSptLow	setpoint temperature value when the air temperature value is AirAtSptLowH
P0611	AirAtSptLowH	external air temperature value where the calculated setpoint takes on the value given by HSptLow
P0612	HSptHigh	setpoint temperature value when the air temperature value is AirAtSptHighH
P0613	AirAtSptHighH	external air temperature value where the calculated setpoint takes on the value given by HSptHigh

P0606 / P0609: Cooling
 P0610 / P0613: Heating

6.12 Water reset

- ⚠ Menu accessible only after having entered the password.
 - ⚠ Access reserved only to specifically trained personnel.
 - ⚠ The parameter modification can cause irreversible damages.
- The water reset correction affects the setpoint defined by the Climate curve TExt (actual setpoint).
 The setpoint is shown at status S0052: ActualUtSetp
 Only if P0003: En WaterReset ≠ 0
 Path: Main menu / Unit parameters / Water reset config

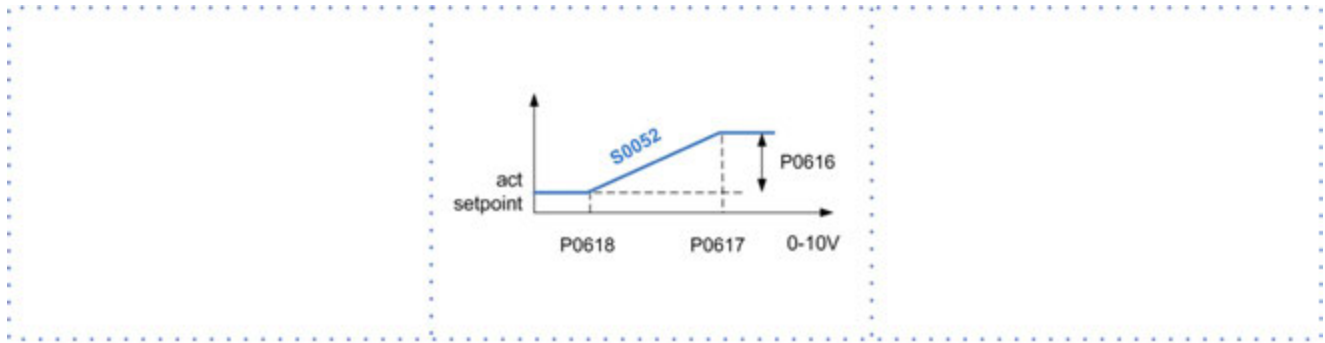

Step	Display	Action	Menu/Variable	Keys		Notes
1		Press 3 sec.		✓		
2	Password	Set	Password	▼	✓	
3		Press		i		
4	Main menu	Select	Unit parameters	▼	✓	
5	Unit parameters	Select	Water reset	▼	✓	
6	Water reset	Select	Parameter	▼	✓	
7		Set		▼	▲	
8		Confirm		✓		
9		Press 3 sec.		⏏		
10		Select	Local connections	✓		

Path: Main Menu / Unit parameters / Water reset

Parameters	Short description	Description
P0616	MaxCWRC	Maximum correction to be applied to the setpoint Cooling
P0617	SWRMaxC	Value of the WR control signal corresponding to the correction of the set Cool equal to P0616
P0618	SWRMinC	Value of the WR control signal corresponding to the correction of the set COOL equal to 0
P0615	MaxCWRH	Maximum correction to be applied to the setpoint Heating
P0619	SWRMaxH	Value of the WR control signal corresponding to the correction of the set Heating equal to P0615
P0620	SWRMinH	Value of the WR control signal corresponding to the correction of the set Heating equal to 0

P0616 / P0618: Cooling
 P0615, P0619, P0620: Heating

6.13 ECOSHARE function for the automatic management of a group of units

- Max 7 units
- Maximum length of the bus line: 700 m.
- Maximum distance between 2 units: 300 m
- Type of cable: shielded twisted pair cable Ø 0,8 mm. use an EIB/KNX cable
- Possible connections: Tree, star, in/out bus, mixed
- It is not possible to use a ring connection
- No end-of-line resistor or terminator required
- There must be suitable arresters to protect the serial lines from the effects of atmospheric discharges
- The data line must be kept separate from the power conductors or powered at different voltage values and away from possible sources of electrical interference

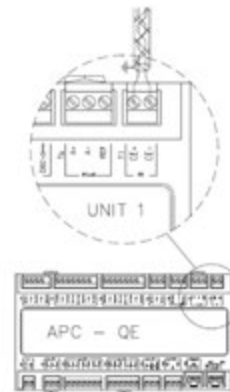
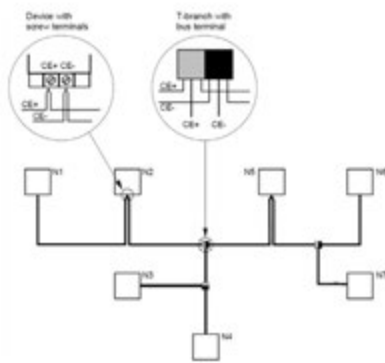

Tree topology (with stub lines)

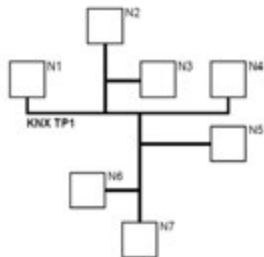

Line topology (with loops)

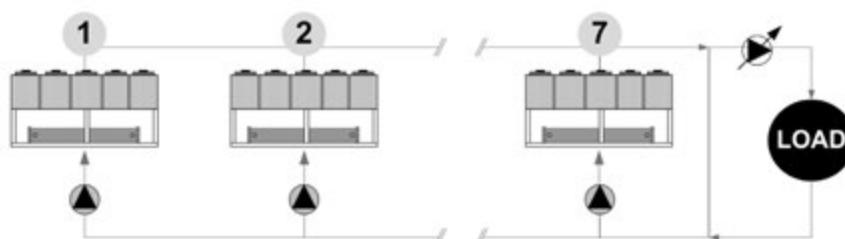
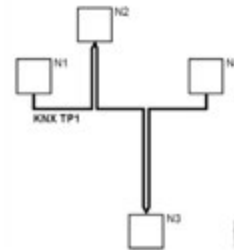

If there are more units connected in a local network set the mode of operation.

MODE A

Every unit manages its own compressors according to the setpoint.

Every unit optimizes its refrigeration circuits.

Pumps always active, even with compressor stoped.

P0658 = 0

P0657 > 0 °C

setpoint1 > setpoint2 > setpoint3

or

setpoint1 < setpoint2 < setpoint3

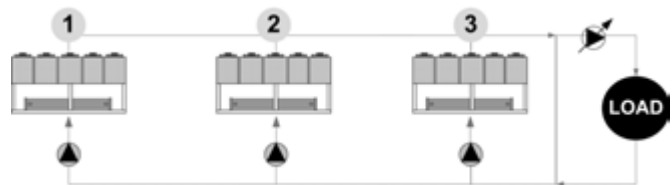

MODE B

The master manages the single cooling.

The master optimizes individual refrigerant circuits.

Pumps always active, even with compressor stoped.

P0658 = 1

P0657 = 0 °C

setpoint1 = setpoint2 = setpoint3

plus: optimal H2O temperature control

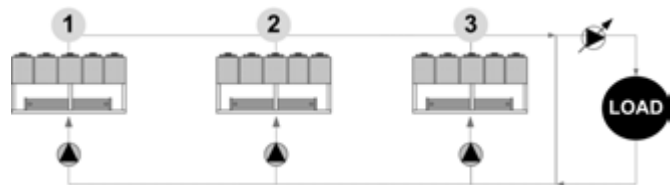

MODE C

The master manages the single cooling.

The master optimizes individual refrigerant circuits.

Active pumps only with active compressors.

P0658 = 2

P0657 = 0 °C

setpoint1 = setpoint2 = setpoint3

plus: minimum pumps consumption need balanced system (t1 = t2 = t3)

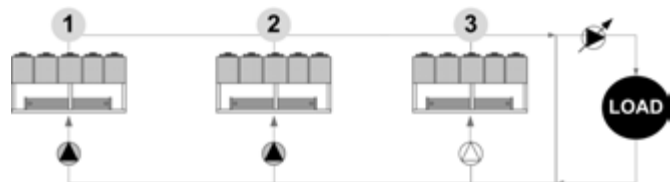

Path: Main Menu / Unit parameters / Master Slave

Parameters	Short description	Description
P0655	LNinstalledUnits	Number of network-connected units including the master
P0656	LNStandByUnits	Number of units kept in standby
P0657	LNOffset	Temperature Offset the master sum or subtract, depending on the way you set, in order of priority, to the set point of the slave
P0658	TypeRegMS	Operation mode: 0=mode A; 1=mode B; 2=mode C
P0659	LNAddress	ProcessBus address unit

6.14 Evaporator water flow-rate

Check that the difference between the temperature of exchanger return and supply water corresponds to power according to this formula:

$$\text{unit cooling power (kW)} \times 860 = \text{Dt (}^\circ\text{C)} \times \text{flow rate (L/h)}$$

The cooling power is shown in the table of the GENERAL TECHNICAL DATA included in this manual, referred to specific conditions, or in the tables on COOLING PERFORMANCE in the TECHNICAL BULLETIN referred to various conditions of use.

Check for water side exchanger pressure drops:

determine the water flow rate

measure the difference in pressure between exchanger input and output and compare it with the graph on WATER SIDE EXCHANGER PRESSURE DROPS

The measurement of pressure will be easier if pressure gauges are installed as indicated in the DIAGRAM OF SUGGESTED WATER CONNECTIONS.

6.15 Inverter driven variable flow-rate user side control depending on the temperature differential

This option allows water flow-rate modulation to the unit during partial load conditions, maintaining stable the temperature difference between inlet and outlet to the heat exchanger.

Designed for systems with primary circuit variable flow-rate systems decoupled from secondary circuit. With no building load the unit switches off the compressors while concerning pumps is possible to select:

- active pumps with minimum flow-rate, monitoring secondary circuit temperature variations (par. P0079 EnQVarUtil = 2; par. P0080 DelayPeriodUt = < 60 sec)
- Pump switching off, periodically activating them (settable time par P0080 DelayPeriodUt) leading secondary circuit temperatures on primary circuit (par. P0079 EnQVarUtil = 0)
- Pump switching off and waiting for the user signal for activation (free potential; par. P0079 EnQVarUtil = 0)

Flow-rate modulation is managed by embedded logic thanks to built-in flow-rate control device and temperature probes. This device is installed and wired.



This option is available only with inverter driven HYDROPACK selected (2PMV / 3PMV)

6.16 Scroll compressor

The Scroll compressors have only one rotation direction.

In the event it is reversed, the compressor is not immediately damaged, but increases its noise and jeopardises pumping.

After a few minutes, the compressor blocks due to intervention of the thermal protection.

In this case, disconnect power supply and invert 2 phases on the machine power supply.

Avoid the compressor working for a long time with contrary rotation: more than 2-3 of these anomalous start-ups can damage it.

To ensure the rotation direction is correct, measure the condensation and suction pressure.

The pressures must significantly differ: upon start-up, the suction pressure decreases whereas the condensation one, increases.

6.17 Operating at reduced load

The units are equipped with partialization steps and they can, therefore, operate with reduced loads.

However a constant and long operation with reduced load with frequent stop and start-up of the compressor/s can cause serious damages for the lack of oil return.

The above-described operating conditions must be considered outside the operating limits.

In the event of compressor breakdown, due to operating in the above-mentioned conditions, the guarantee will not be valid and Clivet spa declines any responsibility.

Check periodically the average operating times and the frequency of the compressors starts: approximately the minimum thermal load should be such as to need the operating of a compressor for at least ten minutes.

If the average times are close to this limit, take the proper corrective actions.

6.18 Start-up report

Identifying the operating objective conditions is useful to control the unit over time.

With unit at steady state, i.e. in stable and close-to-work conditions, identify the following data:

- total voltages and absorptions with unit at full load
- absorptions of the different electric loads (compressors, fans, pumps etc)
- temperatures and flows of the different fluids (water, air) both in input and in output from the unit
- temperature and pressures on the characteristic points of the refrigerating circuit (compressor discharge, liquid, intake)

The measurements must be kept and made available during maintenance interventions.

6.19 2014/68/UE PED directive

DIRECTIVE 2014/68/UE PED gives instructions for installers, users and maintenance technicians as well.

Refer to local regulations; briefly and as an example, see the following:

Compulsory verification of the first installation:

- only for units assembled on the installer's building site (for ex. Condensing circuit + direct expansion unit)

Certification of setting in service:

- for all the units

Periodical verifications:

- to be executed with the frequency indicated by the Manufacturer (see the "maintenance inspections" paragraph)

7 Control

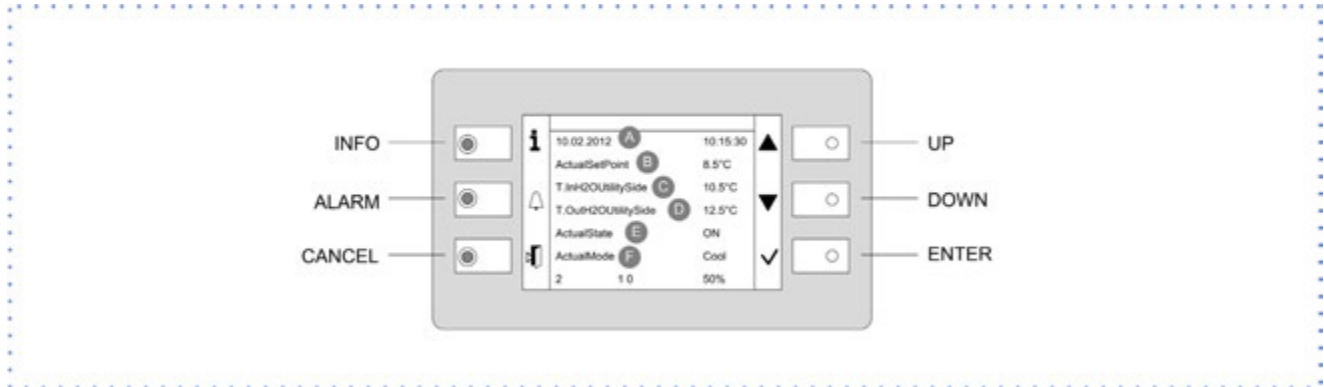

7.1 Led

INFO	Not used
ALARM	Blink / fixed = alarm present
CANCEL	not used currently

Heat: Heating (not used)

7.2 Display

Ref.	Variable	Description
A		Date - Time
B	ActualSetPoint	Temperature setting
C	T.InH2OUtilitySide	Water inlet temperature utility side
D	T.OutH2OUtilitySide	Water outlet temperature utility side
E	ActualState	On / off / eco / pmp On
F	ActualMode	Cool: water cooling Heat: HEATING
	2	Installed compressors
	1 - 0	Compressors ON example: circuit 1 = 1 compr. On circuit 2 = 0 compr. On
	50%	Heating capacity

7.3 Keys

Symbol	Name	Description
	Info	Main menu
	Alarm	Alarm display
	Cancel	Exit Previous level Keyboard settings
	Up	Increases value
	Down	Decreases value
	Enter	Confirm Password

7.4 Change unit state

Step	Display	Action	Menu/Variable	Keys		Notes
1		Press				
2	Main menu	Select	Cmd Local state			
3		Set	OFF - ECO - ON - Pump On			*
4		Confirm				
6		Exit				

* Local state

ECO: recurrent pump ON-OFF; compressors keep water system at setpoint ECO

Pmp ON: pump ON, compressor OFF

7.5 Change the mode

Step	Display	Action	Menu/Variable	Keys		Notes
1		Press				
2	Main menu	Select	Cmd Local mode			
3		Set	Cool: water cooling Heat: HEATING			
4		Confirm				
5		Exit				

















7.6 Modify setpoint

Step	Display	Action	Menu/Variable	Keys		Notes
1		Press				
2	Main menu	Select	Unit parameters			
3	Unit parameters	Confirm	Set Point			
4		Select	Set Point			
5		Set	Set Point			
6		Confirm				
7		Exit				













Parameters	Short description	Description	
P0583	SetPointCooling	Setpoint Cool	
P0584	2SetPointCooling	2° Setpoint Cool	Enable by remote switch
P0855	SetPointECOCooling	Economic summer SetPoint	
P0577	SetPointHeating	Setpoint Heat	
P0578	2SetPointHeating	2° Setpoint Heat	
P0579	SetPointECOHeating	Economic winter SetPoint	
P0640	SetPointRecover	Recovery Set Point	
P0580	ACSSetPoint	domestic hot water set point	

7.7 Scheduler

It is possible to set 6 events (Off, Eco, On, Recirculating) for each week day.







Step	Display	Action	Menu/Variable	Keys		Notes
1		Press				
2	Main menu	Select	Scheduler			
3	Scheduler	Select	Day			
4		Select	Time			
5		Set	Event time			
6		Confirm				
7		Select	Value			
8		Set	On/Eco..			
9		Confirm				
10		Exit				

Enable Scheduler

Step	Display	Action	Menu/Variable	Keys		Notes
1		Press 3 sec.				
2	Password	Set	Password			
3		Press				*
4	Main menu	Select	Unit Parameters			
5		Select	Option config			
6		Set	P0052=1			
7		Press 3 sec.				
		Select	Local connections			

* Unit Parameters menu is displayed

7.8 Display the status

Step	Display	Action	Menu/Variable	Keys		Notes
1		Press				
2	Main menu	Select	Machine State			
3		Select	General, circuit, ecc..			
4		Exit				

Nr.	GENERAL STATA
50	Current Mode
51	Current Status
52	Current Setpoint User-side
53	Steps Qty
54	Steps On
55	Current Setpoint Recovery
56	Alarms
57	Warning
58	Recovery Request
59	User-side Request
60	Domestic Hot Water Status
801	Recovery Pump 1 Hours
802	Recovery Pump 2 Hours
803	Recovery Pump 3 Hours
-	Bitmap Alarms 1
-	Bitmap Alarms 2
-	Bitmap Alarms 3
-	Bitmap Alarms 4

Nr.	USER-SIDE STATA
80	User-side Pump 1 Command
81	User-side Pump 2 Command
82	User-side Pump 3 Command
83	User-side Inverter Command
84	User-side Inverter Signal
85	User-side Inverter Reset
86	Pump On for Anti-freeze
87	Anti-freeze Heaters User side
88	User-side Flow Request
89	LimitFlow Heating
90	LimitFlow Recovery
91	LimitFlow Cooling
92	User-side Pump 1 Hours
93	User-side Pump 2 Hours
94	User-side Pump 3 Hours

Nr.	SOURCE STATA
70	Source Pump 1 Command
71	Source Pump 2 Command
72	Source Pump 2 Command
73	Source Inverter Command
74	Source Inverter Signal
75	Source Inverter Reset
1601	Source Pump 1.1 Hours
1602	Source Pump 2.1 Hours
1603	Source Pump 3.1 Hours
2601	Source Pump 1.2 Hours
2602	Source Pump 2.2 Hours
2603	Source Pump 3.2 Hours

Nr	CIRCUIT 1 STATA
1001	Current Schema 1.1
1002	SubCooling
1003	Current capacity %
1004	Pressure ratio
1005	Envelope Zone 1.1
1006	Envelope Zone 2.1
1007	Envelope Zone 3.1
1008	Offset Envelope 1.1
1009	Superheat Set PID 3.1
1100	Defrost Command 1.1
1101	Superheat Set PID 1.1
1102	Superheat Set PID 2.1
1103	Number Compressors On
1104	Compressor 1.1 Starts
1105	Compressor 2.1 Starts
1106	Compressor 3.1 Starts
1107	Compressor 1.1 Hours
1108	Compressor 2.1 Hours
1109	Compressor 3.1 Hours
-	EEV PID 1 controller status
-	EEV PID 2 controller status
-	EEV PID 3 controller status
-	Source EEV 1
-	Source EEV 2
-	User-side EEV
-	Bitmap Alarms 1.1
-	Bitmap Alarms 2.1
-	Bitmap Alarms 3.1
-	Bitmap Alarms 4.1









Nr.	DIGITAL INPUT
100	2nd Setpoint User-side
101	Recovery System Load
102	User-side System Load
103	Domestic Hot Water Request
104	Recovery Request
105	User-side Request
106	F.C. O. YV Cool
107	F.C. O. YV Heat
108	F.C. C. YV Cool
109	F.C. C. YV Heat
110	Free-cooling Flow
111	Recovery Flow
112	Source Flow
113	User-side Flow
114	Remote Heat/Cool
115	Remote On/Off
116	Phase Monitor
117	Free-cooling Pressure
118	Recovery Inverter Protection
119	Source Inverter Protection
120	User-side Inverter Protection
121	Free-cooling Pump 1 Protection
122	Recovery Pump 1 Protection
123	Source Pump 1 Protection
124	User-side Pump 1 Protection
125	Free-cooling Pump 2 Protection
126	Recovery Pump 2 Protection
127	User-side Pump 2 Protection
128	Free-cooling Pump 3 Protection
129	Recovery Pump 3 Protection
130	Source Pump 3 Protection
131	User-side Pump 3 Protection
132	Leak Detector
138	Source Pump 2 protection
139	Source System Load
1180	High Pressure 1.1
1181	Compressor 1.1 Protection
1182	Compressor 2.1 Protection
1184	Source Fan 1.1 Protection
2180	High Pressure 1.2
2181	Compressor 1.2 Protection
2183	Compressor 2.2 Protection
2184	Source Fan 1.2 Protection

Nr.	ANALOGIC INPUT
201	Demand Limit
202	User-side Differential Pressure switch
203	Free-cooling Water Temperature
204	External Air Temperature
205	Recovery In Temperature
206	Recovery Out Temperature
207	Cabinet Temperature
208	Water Reset
830	User-side In Temperature
831	User-side Out Temperature
885	Source In Temperature
886	Source Out Temperature
1201	Suction Pressure 1.1
1202	Suction Pressure 2.1
1203	Discharge Pressure 1.1
1204	Suction Temperature 1.1
1205	Suction Temp 2.1
1206	Suction Temperature 3.1
1207	Source In Temperature 1.1
1208	Recovery Liquid Temperature 1.1
1209	Source Out Temperature 1.1
1210	Discharge Temperature 1.1
1211	Discharge Temperature 2.1
2201	Suction Pressure 1.2
2202	Suction Pressure 2.2
2203	Discharge Pressure 1.2
2204	Suction Temperature 1.2
2205	Suction Temperature 2.2
2206	Suction Temperature 3.2
2207	Source In Temperature 1.2
2208	Recovery Liquid Temperature 1.2
2209	Source Out Temperature 1.2
2210	Discharge Temperature 1.2
2211	Discharge Temperature 2.2

Nr.	OUTPUT ANALOGICI
301	User-side YV Bypass
302	Grouped Alarms
303	Free-cooling Pump 1
304	Recovery Pump 1
305	Free-cooling Pump 2
306	Recovery Pump 2
307	Free-cooling Pump 3
308	Recovery Pump 3
309	Anti-freeze Heaters
310	Free-cooling Heaters
311	Cabinet Heating
312	Cabinet Fan
313	Domestic Hot Water Valve
314	Free-cooling Valve Open
315	Free-cooling Valve Close
318	YV 1 Cooling
319	YV 2 Heating
320	YV 3 Cooling
321	YV 4 Heating
1301	Aries / Defrost Injection 1.1
1302	Source Pump 1.1 Command
1303	Compressor 1.1 Command
1304	Compressor 2.1 Command
1305	Liquid Injection 1.1
1306	Liquid Injection 2.1
1307	RecValve Battery 1.1
1308	RecValve Chiller 1.1
1309	RecValve Recovery 1.1
1310	Reversing Cycle Valve 1.1
2301	Aries / Defrost Injection 1.2
2302	Source Pump 2.1 Command
2303	Compressor 1.2 Command
2304	Compressor 2.2 Command
2305	Liquid Injection 1.2
2306	Liquid Injection 2.2
2307	RecValve Battery 1.2
2308	RecValve Chiller 1.2
2309	RecValve Recovery 1.2
2310	Reversing Cycle Valve 1.2

Nr.	ANALOGIC OUTPUT
401	Free-cooling Valve
402	Recovery Pump Signal
1401	Source Fan 1.1
2401	Source Fan 1.2

7.9 Keyboard settings

Step	Display	Action	Menu/Variable	Keys		Notes
1		Press 3 sec.				
2		Press				
3	HMI Settings	Select				
4		Press				
5		Press				
6		Select	Local connections			

7.10 Alarms



Before resetting an alarm identify and remove its cause.

Repeated resets can cause irreversible damage.















Example:

+ eE0001: Phase monitor: Fault = active alarm

- EE0003: Pum 1 faulty: Ok = resetted alarm

Display of alarm: step 1-3

Reset allarm: step 4-10

Step	Display	Action	Menu/Variable	Keys		Notes
1		Press				
2	Alarm list detail	Press				
3	Alarm list	Select	Alarm			
4	Alarm list detail	Press 3 sec.				
5	Password	Set	Enter password			
6	Alarm list detail	Press				
7	Alarm list	Select	Alarm			
8		Select	Reset Executed			
9		Press 3 sec.				
10	Password management	Select	Log off			

For details see:

General list of alarms

7.11 General list of alarms

ELECTRICAL CIRCUIT ALARMS			
Num	Name	Description	Category
eE0001	Phase monitor	Phase monitor fault	Central
EE0003	Pump 1 faulty	User side pump 1 overload protection	GP Ut
EE0004	Pump 2 faulty	User side pump 2 overload protection	GP Ut
EE0005	Pump 3 faulty	User side pump 3 overload protection	GP Ut
eE0008	Utility Inverter Protection	User side inverter overload protection	GP Ut
ee0010	Master Offline	Master unit offline	MS
ee0011	Unit 2 in alarm	2 nd slave unit fault	MS
ee0012	Unit 2 OffLine	2 nd slave unit offline	MS
ee0013	Unit 3 in alarm	3 rd slave unit fault	MS
ee0014	Unit 3 OffLine	3 rd slave unit offline	MS
ee0015	Unit 4 in alarm	4 th slave unit fault	MS
ee0016	Unit 4 OffLine	4 th slave unit offline	MS
ee0017	Unit 5 in alarm	5 th slave unit fault	MS
ee0018	Unit 5 OffLine	5 th slave unit offline	MS
ee0019	Unit 6 in alarm	6 th slave unit fault	MS
ee0020	Unit 6 OffLine	6 th slave unit offline	MS
ee0021	Unit 7 in alarm	7 th slave unit fault	MS
ee0022	Unit 7 OffLine	7 th slave unit offline	MS
ee0027	Utility Water In temp Error	User side in water temperature probe fault	Central
ee0028	Utility Water Out temp Error	User side out water temperature probe fault	Central
ee0029	Temp Ext Sensor Error	External air temperature probe fault	HW
ee0030	DemandLimit	Demand limit fault	HW
ee0031	WaterReset	Water reset fault	HW
ee0032	External Humidity probe Error	Relative humidity probe fault	HW
ee0033	T.Quadro Ele	Electrical panel temperature probe fault	HW
ee0035	YV Cool Open	YV Cool opening fault	4P
ee0036	YV Heat Open	YV Heat opening fault	4P
ee0037	YV Cool Close	YV Cool closing fault	4P
ee0038	YV Heat Close	YV Heat closing fault	4P
ee0040	FCI Water Temp.	Freecooling water temperature probe fault	HW FCI
EE0044	Pump 1 Allarm	Freecooling pump 1 overload protection	FCI Circuit 1
EE0045	Pump 2 Allarm	Freecooling pump 2 overload protection	FCI Circuit 1
EE0046	Pump 3 Allarm	Freecooling pump 3 overload protection	FCI Circuit 1
ee0047	Pump Change for Utility Flow	Switching pump on user side for flow alarm	GP User side
ee0050	P.DifferenzialeUtil	User side differential pressure sensore fault	HW
EE0054	Recovery Pump 1 protection	Recovery side pump 1 overload protection	Recovery
EE0055	Recovery Pump 2 protection	Recovery side pump 2 overload protection	Recovery
EE0056	Recovery Pump 3 protection	Recovery side pump 3 overload protection	Recovery
eE0057	Recovery Inverter Protection	Recovery side inverter overload protection	Recovery
ee0100	TimeOutModPOL98U	1 st POL98U module disconnected	HW TimeOut
ee0101	TimeOutModPOL98U_2	2 nd POL98U module disconnected	HW TimeOut
ee0102	TimeOutModPOL96U	POL96U module disconnected	HW TimeOut
ee0103	TimeOutModPOL945	POL945 module disconnected	HW TimeOut

ELECTRICAL CIRCUIT ALARMS			
Num	Name	Description	Category
ee0104	TimeOutModPOL965	POL965 module disconnected	HW TimeOut
ee0105	TimeOutModPOL94U	1 st POL94U module disconnected	HW TimeOut
ee0106	TimeOutModPOL94U_2	2 nd POL94U module disconnected	HW TimeOut
ee0107	TimeOutModPOL985	POL985 module disconnected	HW TimeOut
ee1001	T.Suction Gas	Gas temperature probe 3 fault	HW Circuit 1
ee1002	T.Suction Gas	Gas temperature probe 5 fault	HW Circuit 1
ee1003	P.Suction Heat	Pressure sensor fault, low pressure heating	HW Circuit 1
ee1004	EEV1 blocked	EEV 1 blocked	Circuit 1
ee1005	EEV1 blocked	EEV2 blocked	Circuit 1
EE1006	Comp 1 protections	Compressor 1 overload protection	Circuit 1
EE1007	Comp 2 protections	Compressor 2 overload protection	Circuit 1
EE1008	Comp 3 protections	Compressor 3 overload protection	Circuit 1
EE1009	Source Inverter Protection	Source side inverter overload protection	Source 1
ee1010	Pump Change for Source Flow	Switching pump on source side for flow alarm	Source 1
EE1013	Source Pump 1 protection	Source side pump 1 overload protection	Source 1
EE1014	Source Pump 2 protection	Source side pump 2 overload protection	Source 1
EE1015	Source Pump 3 protection	Source side pump 3 overload protection	Source 1
EE1018	Source side protection	Source side ventilation overload protection	Circuit 1
ee1022	T.Discharge C1.1	Compressor 1 discharge temperature probe fault	HW Circuit 1
ee1023	T.Discharge C2.1	Compressor 2 discharge temperature probe fault	HW Circuit 1
ee1024	T.Discharge C3.1	Compressor 3 discharge temperature probe fault	HW Circuit 1
ee1025	T.Source 1	Source 1 temperature probe fault	HW Circuit 1
ee1026	T.Source 2	Source 2 temperature probe fault	HW Circuit 1
ee1027	T.Suction Gas	Suction temperature probe fault	HW Circuit 1
ee1028	P.Discharge	High pressure probe fault	HW Circuit 1
ee1029	P.Suction	Low pressure probe fault	HW Circuit 1
ee1030	T.GasRecovery	Recovery exchanger gas temperature probe fault	HW Circuit 1
ee1031	P.GasRecovery	Recovery exchanger gas pressure probe fault	HW Circuit 1
ee1032	T.Ing Recovery	Recovery in temperature probe fault	HW Circuit 1
ee1033	T.Out Recovery	Recovery out temperature probe fault	HW Circuit 1
ee1037	Alarm Inverter 1	Inverter 1 in alarm	Inverter APY
ee1038	Alarm missing comunication inv1	Inverter 1 Modbus communication error	Inverter APY
ee1039	Timeout comunication inv1	Inverter 1 communication timeout	Inverter APY
ee1040	Alarm Inverter 2	Inverter 2 in alarm	Inverter APY
ee1041	Alarm missing comunication inv2	Inverter 2 Modbus communication error	Inverter APY
ee1042	Timeout comunication inv2	Inverter 2 communication timeout	Inverter APY
ee1043	Alarm Inverter 3	Inverter 3 in alarm	Inverter APY
ee1044	Alarm missing comunication inv3	Inverter 3 Modbus communication error	Inverter APY
ee1045	Timeout comunication inv3	Inverter 3 communication timeout	Inverter APY
EE1047	Alarm Envelop Comp1	Compressor 1 envelope alarm	Circuit 1
EE1048	Alarm Envelop Comp2	Compressor 2 envelope alarm	Circuit 1
EE1049	Alarm Envelop Comp3	Compressor 3 envelope alarm	Circuit 1
ee1055	Alarm Inverter 1	Inverter 1 in alarm	Inverter DFS
ee1056	Alarm missing comunication inv1	Inverter 1 Modbus communication error	Inverter DFS
ee1057	Timeout comunication inv1	Inverter 1 communication timeout	Inverter DFS

ELECTRICAL CIRCUIT ALARMS			
Num	Name	Description	Category
ee1058	Alarm Inverter 2	Inverter 2 in alarm	Inverter DFS
ee1059	Alarm missing communication inv2	Inverter 2 Modbus communication error	Inverter DFS
ee1060	Timeout communication inv2	Inverter 2 communication timeout	Inverter DFS
ee1061	Alarm Inverter 3	Inverter 3 in alarm	Inverter DFS
ee1062	Alarm missing communication inv3	Inverter 3 Modbus communication error	Inverter DFS
ee1063	Timeout communication inv3	Inverter 3 communication timeout	Inverter DFS
ee1070	User side ECV 1.1	User side ECV connection problem	HW Circuit 1
ee1071	Source ECV 1.1	Source side ECV 1 connection problem	HW Circuit 1
ee1072	Source ECV 2.1	Source side ECV 2 connection problem	HW Circuit 1
ee2001	T.Suction Gas	Gas temperature probe 4 fault	HW Circuit 2
ee2002	T.Suction Gas	Gas temperature probe 6 fault	HW Circuit 2
ee2003	P.Suction Heat	Pressure sensor fault, low pressure heating	HW Circuit 2
ee2004	EEV1 blocked	EEV1 blocked	Circuit 2
ee2005	EEV1 blocked	EEV2 blocked	Circuit 2
EE2006	Comp 1 protections	Compressor 1 overload protection	Circuit 2
EE2007	Comp 2 protections	Compressor 2 overload protection	Circuit 2
EE2008	Comp 3 protections	Compressor 3 overload protection	Circuit 2
EE2009	Source Inverter Protection	Source side inverter overload protection	Source 2
ee2010	Pump Change for Source Flow	Switching pump on source side for flow alarm	Source 2
EE2013	Source Pump 1 protection	Source side pump 1 overload protection	Source 2
EE2014	Source Pump 2 protection	Source side pump 2 overload protection	Source 2
EE2015	Source Pump 3 protection	Source side pump 3 overload protection	Source 2
EE2018	Source side protection	Source side ventilation overload protection	Circuit 2
ee2022	T.Discharge C1.1	Compressor 1 discharge temperature probe fault	HW Circuit 2
ee2023	T.Discharge C2.1	Compressor 2 discharge temperature probe fault	HW Circuit 2
ee2024	T.Discharge C3.1	Compressor 3 discharge temperature probe fault	HW Circuit 2
ee2025	T.Source 1	Source 1 temperature probe fault	HW Circuit 2
ee2026	T.Source 2	Source 2 temperature probe fault	HW Circuit 2
ee2027	T.Suction Gas	Suction gas temperature probe fault	HW Circuit 2
ee2028	P.Discharge	High pressure probe fault	HW Circuit 2
ee2029	P.Suction	Low pressure probe fault	HW Circuit 2
ee2030	T.GasRecovery	Recovery exchanger gas temperature probe fault	HW Circuit 2
ee2031	P.GasRecovery	Recovery exchanger gas pressure probe fault	HW Circuit 2
ee2032	T.Ing Recovery	Recovery in temperature probe fault	HW Circuit 2
ee2033	T.Out Recovery	Recovery out temperature probe fault	HW Circuit 2
ee2037	Alarm Inverter 1	Inverter 1 in alarm	Inverter APY
ee2038	Alarm missing communication inv1	Inverter 1 Modbus communication error	Inverter APY
ee2039	Timeout communication inv1	Inverter 1 communication timeout	Inverter APY
ee2040	Alarm Inverter 2	Inverter 2 in alarm	Inverter APY
ee2041	Alarm missing communication inv2	Inverter 2 Modbus communication error	Inverter APY
ee2042	Timeout communication inv2	Inverter 2 communication timeout	Inverter APY

ELECTRICAL CIRCUIT ALARMS			
Num	Name	Description	Category
ee2043	Alarm Inverter 3	Inverter 3 in alarm	Inverter APY
ee2044	Alarm missing comunication inv3	Inverter 3 Modbus communication error	Inverter APY
ee2045	Timeout comunication inv3	Inverter 3 communication timeout	Inverter APY
EE2047	Alarm Envelop Comp1	Compressor 1 envelope alarm	Circuit 2
EE2048	Alarm Envelop Comp2	Compressor 2 envelope alarm	Circuit 2
EE2049	Alarm Envelop Comp3	Compressor 3 envelope alarm	Circuit 2
ee2055	Alarm Inverter 1	Inverter 1 in alarm	Inverter DFS
ee2056	Alarm missing comunication inv1	Inverter 1 Modbus communication error	Inverter DFS
ee2057	Timeout comunication inv1	Inverter 1 communication timeout	Inverter DFS
ee2058	Alarm Inverter 2	Inverter 2 in alarm	Inverter DFS
ee2059	Alarm missing comunication inv2	Inverter 2 Modbus communication error	Inverter DFS
ee2060	Timeout comunication inv2	Inverter 2 communication timeout	Inverter DFS
ee2061	Alarm Inverter 3	Inverter 3 in alarm	Inverter DFS
ee2062	Alarm missing comunication inv3	Inverter 3 Modbus communication error	Inverter DFS
ee2063	Timeout comunication inv3	Inverter 3 communication timeout	Inverter DFS
ee2070	User side ECV 1.1	User side ECV connection problem	HW Circuit 2
ee2071	Source ECV 1.1	Source side ECV 1 connection problem	HW Circuit 2
ee2072	Source ECV 2.1	Source side ECV 2 connection problem	HW Circuit 2

REFRIGERANT CIRCUIT ALARMS			
Num	Name	Description	Category
ff1005	Min overheating EEV1	Value of refrigerant superheat too low EEV1 (user side)	Circuit 1
ff1006	Min overheating EEV2	Value of refrigerant superheat too low EEV1 (source)	Circuit 1
ff1009	Low Pressure Alarm (DI)	Low Pressure Alarm (DI)	Circuit 1
ff1010	Warning LP Cool	Low Pressure Pre Alarm in Cooling Mode	Circuit 1
ff1011	Warning LP Heat	Low Pressure Pre Alarm in Heating Mode	Circuit 1
ff1012	Low pressure Alarm Heat (AI)	Low Pressure in Heating Mode (AI)	Circuit 1
ff1013	High Pressure (DI)	High Pressure Alarm (DI)	Circuit 1
ff1014	Warning High Pressure	High Pressure Pre Alarm	Circuit 1
ff1015	High Pressure Alarm (AI)	High Pressure Alarm (AI)	Circuit 1
ff1016	Max RC Warning	Maximum Pressure Ratio Pre Alarm	Circuit 1
ff1017	Min RC Alarm	Minimum Pressure Ratio Pre Alarm	Circuit 1
ff1018	Low Pressure Alarm Cool(AI)	Low Pressure Alarm in Cooling Mode	Circuit 1
FF1019	Max RC Alarm	Maximum Pressure Ratio	Circuit 1
FF1034	Vacuum Circuit	Vaacum Alarm	Circuit 1
FF1046	LimLp	Low pressure limit	Circuit 1
ff1047	DFRForced	Defrost Forced	Circuit 1
ff1048	DFRWaterTLow	Low water temperature for defrost operation	Circuit 1
ff1049	DFRTimeMax	Defrost Maximum Time	Circuit 1

REFRIGERANT CIRCUIT ALARMS			
Num	Name	Description	Category
ff2005	Min overheating EEV1	Min Superheat value (user side)	Circuit 2
ff2006	Min overheating EEV2	Min Superheat value (source)	Circuit 2
ff2009	Low Pressure Alarm (DI)	Low pressure Alarm (DI)	Circuit 2
ff2010	Warning LP Cool	Low pressure Pre Alarm CoolingMode	Circuit 2
ff2011	Warning LP Heat	Low pressure Pre Alarm HeatingMode	Circuit 2
ff2012	Low pressure Alarm Heat (AI)	Low pressure Pre Alarm Heating Mode (AI)	Circuit 2
ff2013	High Pressure (DI)	High pressure Alarm (DI)	Circuit 2
ff2014	Warning High Pressure	High pressure Pre Alarm	Circuit 2
ff2015	High Pressure Alarm (AI)	High pressure Alarm (AI)	Circuit 2
ff2016	Max RC Warning	Maximum pressure Ratio Pre Alarm	Circuit 2
ff2017	Min RC Alarm	Minimum pressure Ratio Pre Alarm	Circuit 2
ff2018	Low Pressure Alarm Cool(AI)	Low Pressure Alarm Cooling Mode	Circuit 2
FF2019	Max RC Alarm	Maximum Pressure Radio	Circuit 2
FF2034	Vacuum Circuit	Vaacum Alarm	Circuit 2
FF2046	LimLp	Low pressure limit	Circuit 2
ff2047	DFRForced	Defrost Forced	Circuit 2
ff2048	DFRWaterTLow	Low water temperature for defrost	Circuit 2
ff2049	DFRTimeMax	Defrost Time	Circuit 2

HYDRAULIC CIRCUIT ALARMS			
Num	Name	Description	Category
iI0002	Water pressure	User side low water pressure	GP Ut
iI0006	Flow switch utility side	User side low flow rate	GP Ut
II0007	Freeze alarm	User side Water Frost Protection	Centrale
ii0008	Pumps antifreeze alarm	Pump activation Water Frost Protection	Centrale
II0009	Inconsistent deltaT across the exchanger	Water outlet temperature, discordant with the current operation mode, user side	Centrale
II0042	Pressure allarm	Freecooling low water pressure	FCI Circuito 1
II0043	Freeze alarm	Freecooling water frost protection	FCI Circuito 1
ii0047	Flow switch allarm	Freecooling water low flow rate	FCI Circuito 1
iI0052	Recovery Low H2O Flow	Recovery water low flow rate	Recupero
iI0053	Recovery Low Pressure Plant	Recovery low water pressure	Recupero
iI1017	Source Low Pressure Plant	Source low water pressure	Sorgente 1
iI1020	Source Low H2O Flow	Source side low water flow	Sorgente 1
II1021	Source H2O Freeze Alarm	Source side water frost protection	Sorgente 1
iI2017	Source Low Pressure Plant	Source low water pressure	Sorgente 2
iI2020	Source Low H2O Flow	Source side low water flow	Sorgente 2
II2021	Source H2O Freeze Alarm	Source side water frost protection	Sorgente 2

8 Maintenance

8.1 General description

Maintenance must be done by authorized centres or by qualified personnel.

The maintenance allows to:

- maintain the unit efficiency
- increase the life span of the equipment
- assemble information and data to understand the state of the unit efficiency and avoid possible damages

Before checking, please verify the following:

- the electrical power supply line should be isolated at the beginning
- the unit isolator is open, locked and equipped with the suitable warning
- make sure no tension is present



After turning off the power, wait at least 5 minutes before accessing to the electrical panel or any other electrical component.



Before accessing check with a multimeter that there are no residual stresses.

8.2 Inspections frequency

Perform an inspection every 6 months minimum.

The frequency, however, depends on the use.



In the event of frequent use it is recommended to plan inspections at shorter intervals:

- frequent use (continuous or very intermittent use, near the operating limits, etc)
- critical use (service necessary)

√	intervention frequency (months)	1	6	12
1	presence corrosion			X
2	panel fixing			X
3	fan fixing		X	
4	coil cleaning		X	
5	water filter cleaning		X	
6	water: quality, ph, weight of glycol (%)		X	
7	check the exchanger efficiency			X
8	circulating pumps		X	
9	check of the fixing and the insulation of the power lead			X
10	check of the earthing cable			X
11	electric panel cleaning			X
12	capacity contactor status			X
13	terminal closing, cable insulation integrity			X
14	voltage and phase unbalancing (no load and on-load)		X	
15	absorptions of the single electrical loads		X	
16	test of the compressor crankcase heaters		X	
17	Checking for leaks			*
18	survey of the refrigerant circuit operating parameters		X	
19	safety valve			*
20	protective device test: pressure switches, thermostats, flow switches etc..		X	
21	control system test: setpoint, climatic compensations, capacity stepping, water / air flow-rate variations		X	
22	control device test: alarm signalling, thermometers, probes, pressure gauges etc..		X	

* Refer to the local regulations; and ensure correct adherence. Companies and technicians that effect interventions of installation, maintenance/repairs, leak control and recovery must be CERTIFIED as expected by the local regulations. The leak control must be effected with annual renewal.

8.3 Unit booklet

It's advisable to create a unit booklet to take notes of the unit interventions.

In this way it will be easier to adequately note the various interventions and aid any troubleshooting.

Report on the booklet:

- date
- intervention description
- carried out measures etc.

8.4 Standby mode

If a long period of inactivity is foreseen:

- turn off the power
- avoid the risk of frost (empty the system or add glycol)

Turn off the power to avoid electrical risks or damages by lightning strikes.

With lower temperatures keep heaters turned on in of the electrical panel (option).

It's recommended that the re-start after the stopping period is performed by a qualified technician, especially after seasonal stops or seasonal switching.

When restarting, refer to what is indicated in the "start-up" section.

Schedule technical assistance in advance to avoid hitches and to guarantee that the system can be used when required.

8.5 Air coil

Contact with the exchanger fins can cause cuts: wear protective gloves to perform the above described operations.

It is extremely important that the battery gives the maximum thermal exchange; therefore, its surface must be cleaned from dust and deposits. Remove all impurities from the surface.

Using an air pressure gun, clean the aluminum surface of the battery; be careful to direct the air in the opposite direction of the fan air movement.

Hold the gun parallel to the fins to avoid damages.

As an alternative, vacuum cleaner can be used to suck impurities from the air input side.

Verify that the aluminum fins are not bent or damaged, in the event of damages contact the authorized assistance center and get the fins straightened in order to restore the initial condition for an optimal air flow.

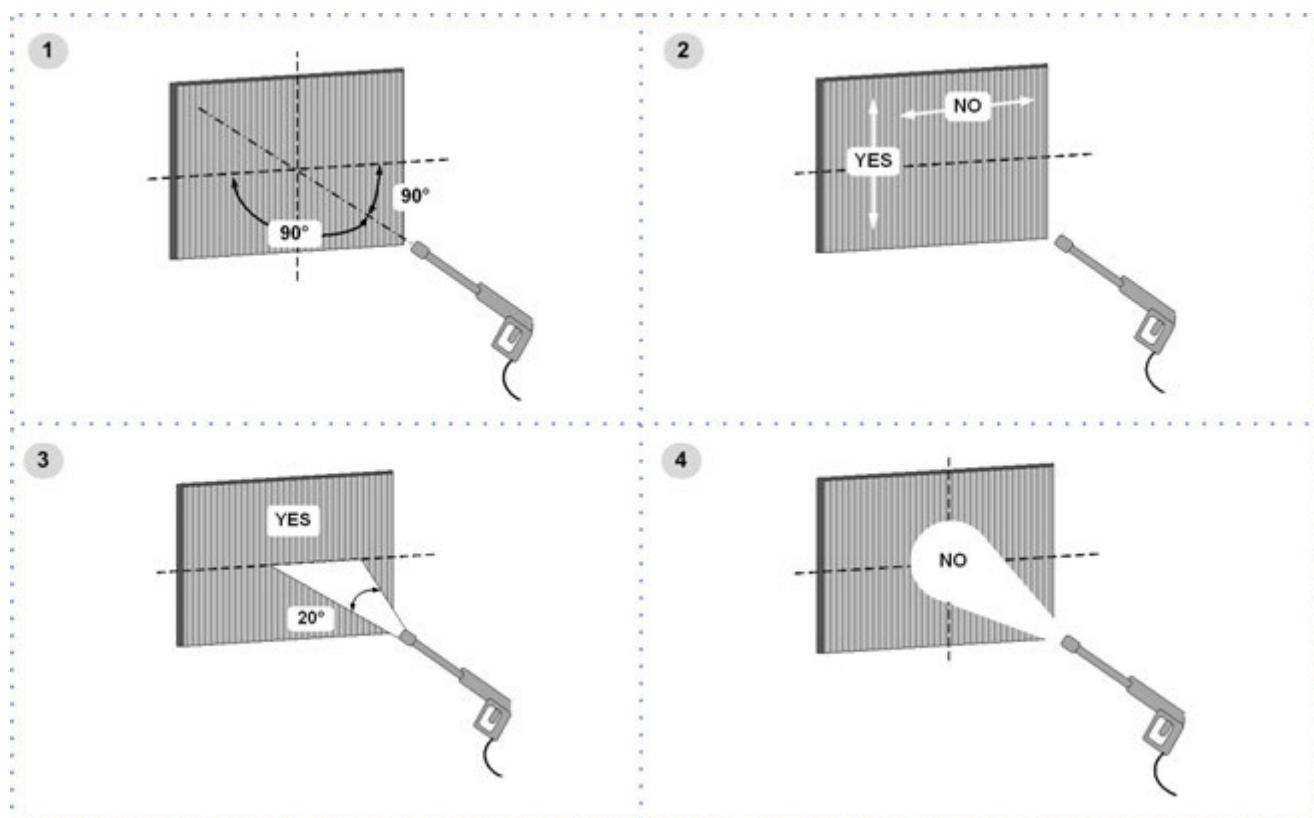

8.6 Electric fans

Check:

- the fans and the relative protection grids are well fixed
- the fan bearings (evident by noise and anomalous vibrations)
- the terminal protection covers are closed and the cable holders are properly positioned

8.7 Water side exchanger

It is very important for the exchanger to be able to provide the maximum thermal exchange, therefore it is essential for the inner surfaces to be clean of dirt and incrustations.

Periodically check the difference between the temperature of the supply water and the condensation temperature: if the difference is greater than 8°C–10°C it is advisable to clean the exchanger.

The clearing must be effected:

- with circulation opposite to the usual one
- with a speed at least 1,5 times higher than the nominal one
- with an appropriate product moderately acid (95% water + 5% phosphoric acid)
- after the cleaning rinse with water to inhibit the action of any residual product

8.8 Circulating pumps

Check:

- no leaks
- bearing status (anomalies are highlighted by abnormal noise and vibration)
- the terminal protection covers are closed and the cable holders are properly positioned

8.9 Insulations

Check the condition of the insulations: if necessary apply glue and and renew the seals.

8.10 Water filter

Check that no impurities prevent the correct passage of water.

8.11 Flow Switch

- controls the operations
- remove incrustations from the palette

8.12 Compressor supply line shut-off valve

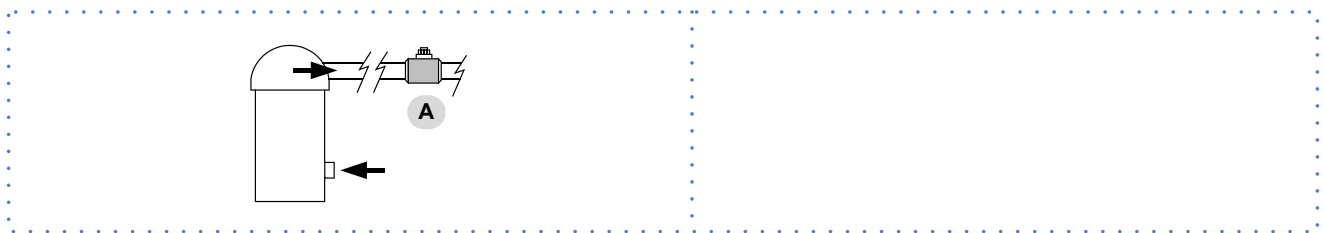

A. Supply line shut-off valve



Do not remove the seal
Remove only if authorized by the manufacturer.
Please contact the maker for informations.

8.13 crankcase heater

Check:

- closure
- Operation



8.14 Copeland scroll compressor

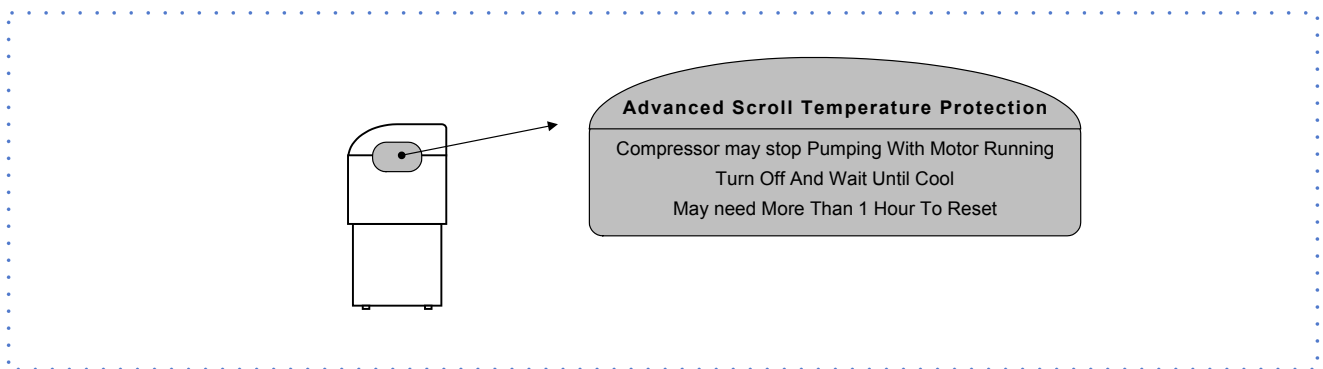

8.15 System discharge

1. evacuate the system
2. evacuate the exchanger, use all the present taps
3. use compressed air to blow the exchanger
4. dry completely the exchanger by an hot air jet; for greater safety fill the exchanger with glycoled solution
5. protect the exchanger from the air
6. remove the drain plugs to the pumps



Any anti-freeze liquid contained in the system should not be discharged freely as it is a pollutant. It must be collected and reused. Before starting a washing the plant.

Example

- emptying pump

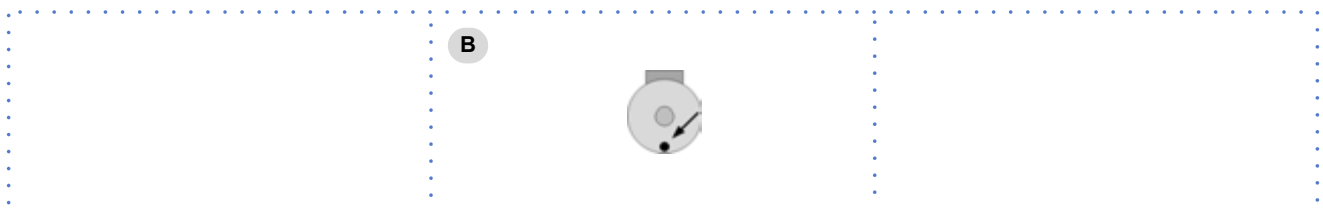

It's recommended that the re-start after the stopping period is performed by a qualified technician, especially after seasonal stops or seasonal switching.

When restarting, refer to what is indicated in the "start-up" section.

Schedule technical assistance in advance to avoid hitches and to guarantee that the system can be used when required.

8.16 Compressor replacement

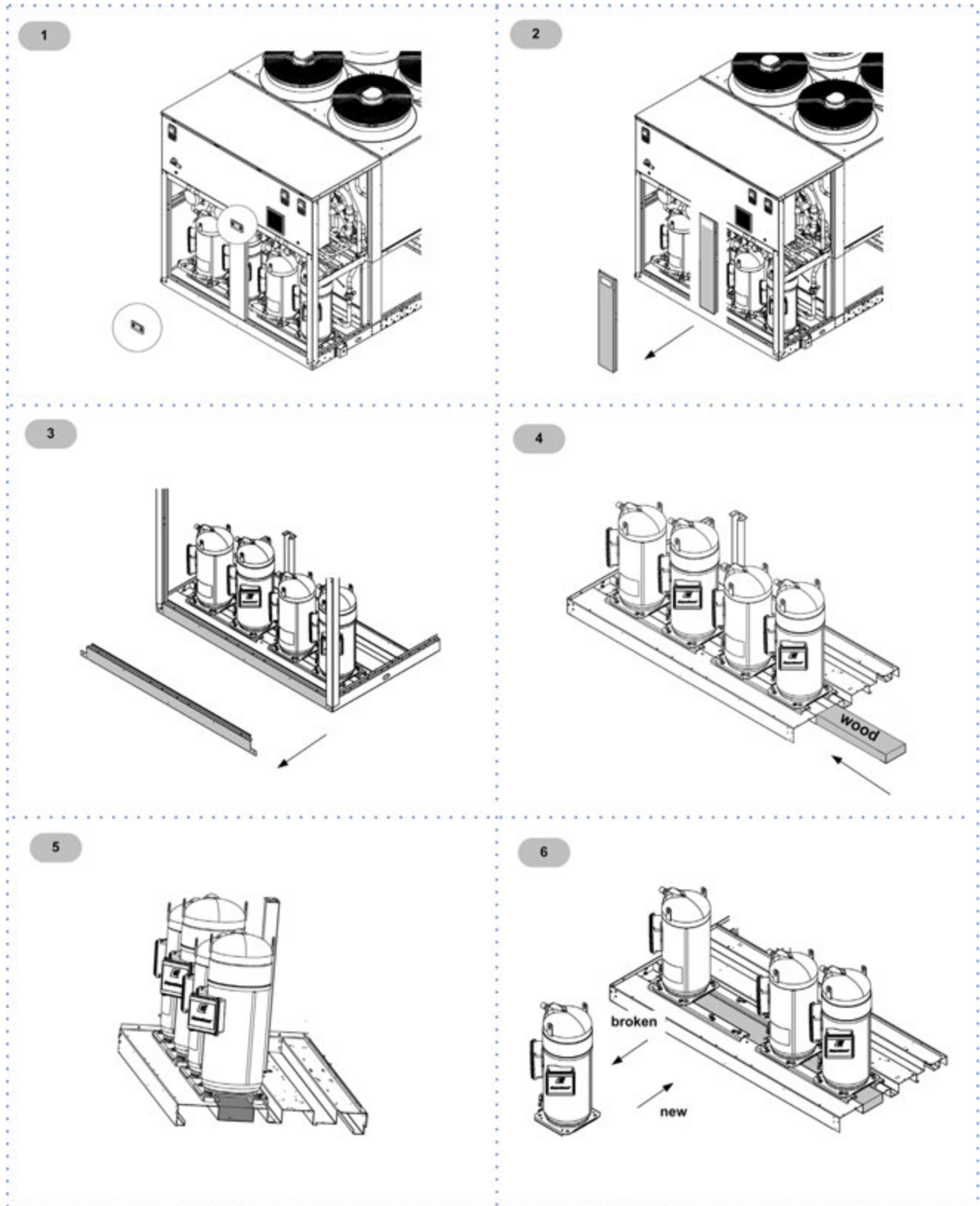

8.17 Exchanger replacement

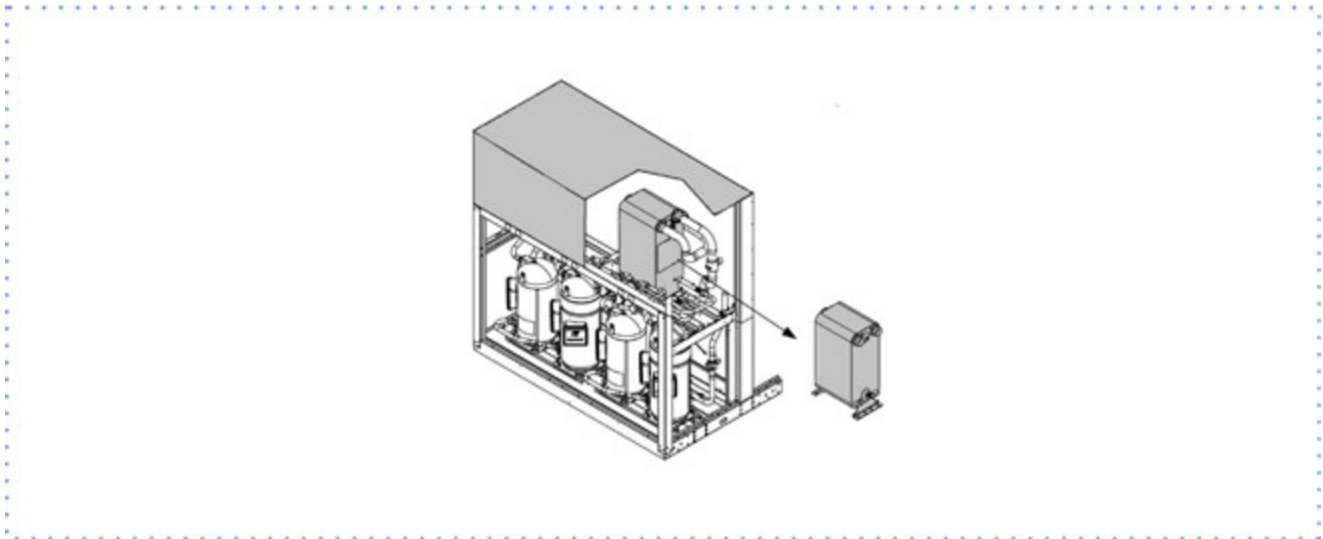

8.18 Pump replacement

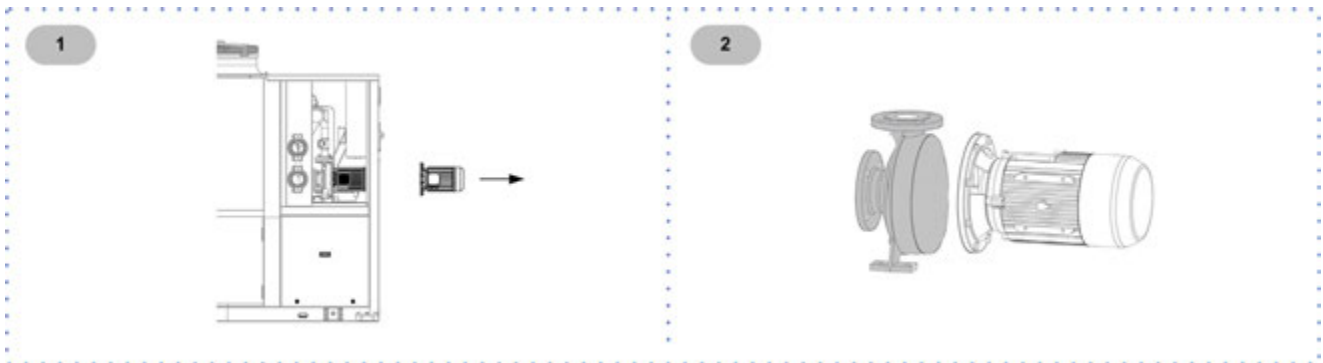

9 Accessories

9.1 Anti-vibration mount support

Antivibranti a molla - Spring antivibration mount

Codice	W1	W2	W3	W4	W5	W6	W7	W8
PE8T00041	RZ420/212/122P	RX403/Z208/112Pr	RZ420/212/122P	RX403/Z208/112Pr				
PE8T00042	RZ522/Z20P	RZ612/X107P	RZ522/Z20P	RZ612/X107P				
PE8T00043	RZ522/Z20P	RZ420/212/122P	RZ522/Z20P	RZ420/212/122P				
PE8T00044	RZ420/212/122P	RZ612/X107P	RZ420/212/122P	RZ612/X107P				
PE8T00045	RX508/Z224P	RZ420/212/122P	RX508/Z224P	RZ420/212/122P				
PE8T00046	RX508/Z224P	RZ522/Z20P	RX508/Z224P	RZ522/Z20P				
PE8T00047	RZ720P	RX703Pr	RZ720P	RX703Pr				
PE8T00048	RZ720P	RX404/203/Z120P	RZ720P	RX404/203/Z120P				
PE8T00049	RZ724P	RX404/203/Z120P	RZ724P	RX404/203/Z120P				
PE8T00050	RZ724P	RX703Pr	RX703Pr	RZ724P	RX703Pr	RX703Pr		
PE8T00051	RX407/204/Z122P	RX407/204/Z122P	RX407/204/Z122P	RX407/204/Z122P				
PE8T00052	RZ724P	RX407/204/Z122P	RZ724P	RX407/204/Z122P				
PE8T00053	RZ724P	RX404/203/Z120P	RX404/203/Z120P	RZ724P	RX404/203/Z120P	RX404/203/Z120P		
PE8T00054	RX407/204/Z122P	RX404/203/Z120P	RX407/204/Z122P	RX404/203/Z120P				
PE8T00055	RZ620/124P	RX603/104Pr	RZ620/124P	RX603/104Pr				
PE8T00056	RZ620/124P	RX603/104Pr	RZ605/X102Pr	RZ620/124P	RX403/Z208/112Pr	RZ605/X102Pr		
PE8T00057	RZ424/X207/108P	RX603/104Pr	RX503/Z205Pr	RZ424/X207/108P	RX403/Z208/112Pr	RX503/Z205Pr		
PE8T00058	RZ620/124P	RX604/107P	RZ620/124P	RX604/107P				
PE8T00059	RZ620/124P	RX604/107P	RX503/Z205Pr	RZ620/124P	RX704P	RX503/Z205Pr		
PE8T00060	RZ424/X207/108P	RZ420/212/X107P	RX504/Z212P	RZ424/X207/108P	RX704P	RX504/Z212P		
PE8T00061	RZ620/X107P	RZ712P	RX402/Z203/108Pr	RZ620/X107P	RZ712P	RX402/Z203/108Pr		
PE8T00062	RX707P	RX604/Z122P	RZ608/X104Pr	RZ620/X107P	RX604/Z122P	RZ608/X104Pr		
PE8T00063	RX707P	RZ608/X104Pr	RZ608/X104Pr	RZ712P	RX507/Z220P	RZ608/X104Pr	RZ608/X104Pr	RZ712P
PE8T00064	RZ620/X107P	RX604/Z122P	RZ608/X104Pr	RZ620/X107P	RX604/Z122P	RZ608/X104Pr		
PE8T00065	RX507/Z220P	RZ620/X107P	RZ712P	RZ620/X107P	RX607/Z124P	RZ712P		
PE8T00066	RX407/Z220/124P	RZ608/112Pr	RX604/Z122P	RX604/Z122P	RX407/Z220/124P	RZ608/112Pr	RX604/Z122P	RX504/Z212P
PE8T00067	RX604/Z122P	RZ620/X107P	RZ712P	RX604/Z122P	RX407/Z220/124P	RZ712P		
PE8T00068	RX507/Z220P	RX402/Z203/108Pr	RX507/Z220P	RX604/Z122P	RX407/Z220/124P	RZ705Pr	RX407/Z220/124P	RX604/Z122P
PE8T00069	RZ622/124P	RX403/202/Z112Pr	RZ608/X104Pr	RZ712P	RZ622/124P	RZ608/X104Pr	RZ608/X104Pr	RZ712P

PE code



W1 Wn : see dimensional drawings IOM manual
vedere disegni dimensionali sul manuale

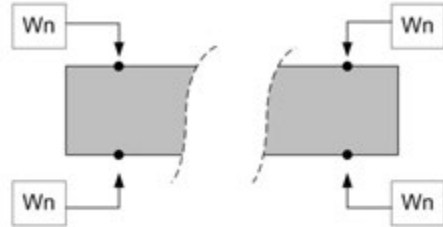

Type: R....

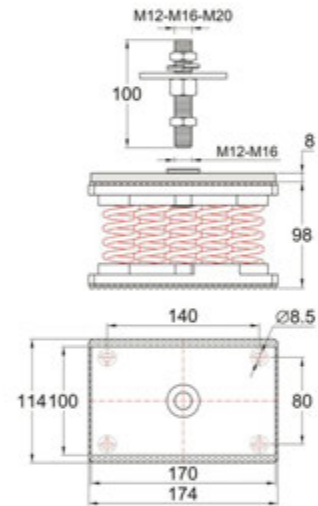

Brugola da 8
Allen key 8th



Chiave del 24
Simple key 24th



1

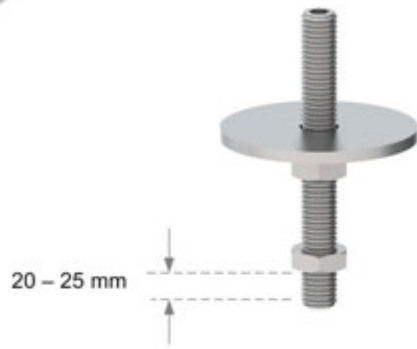

2

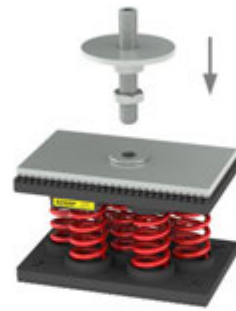

3



4

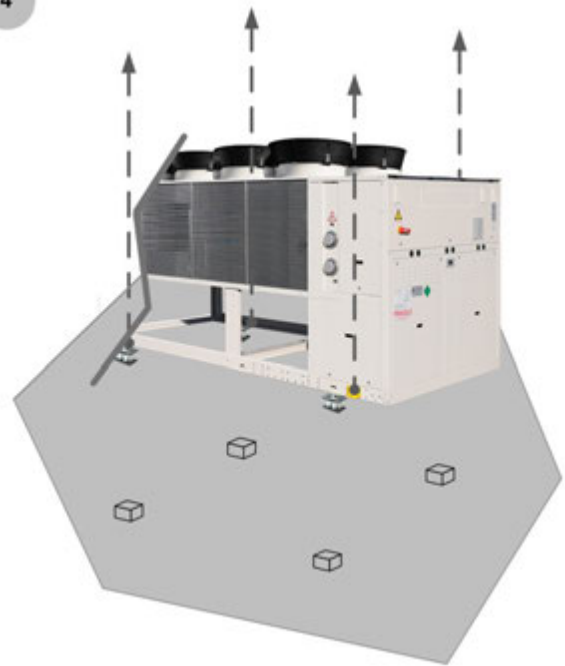

5

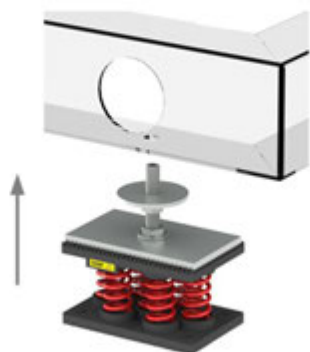

6



7

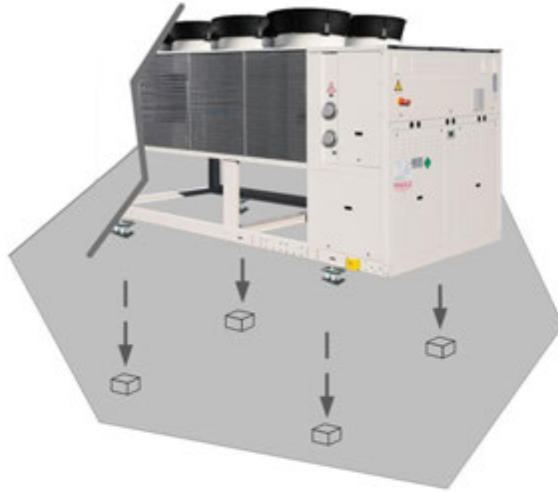

8

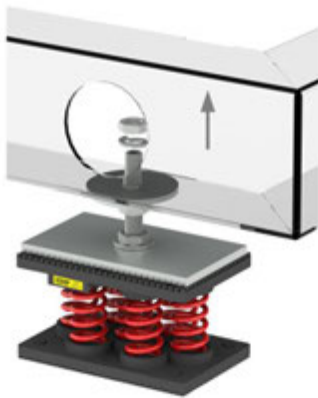

9

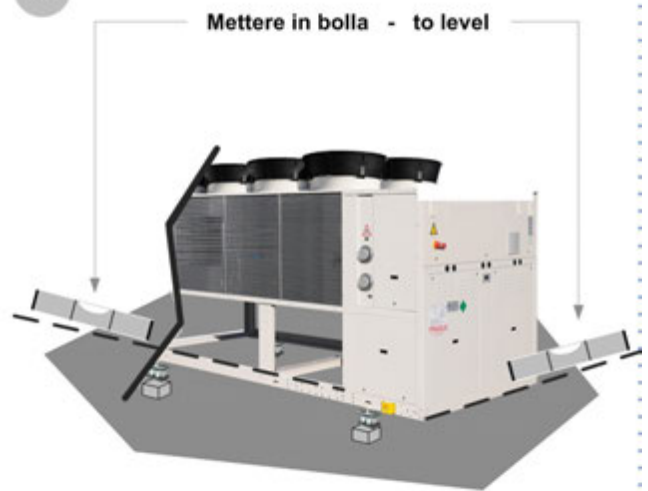

10



9.2 Total energy recovery

A configuration which enables the production of hot water free-of-charge while operating in the cooling mode, thanks to the partial recovery of condensation heat that would otherwise be rejected to the external heat source.

Hot water availability is always subordinate to the production of chilled water.

See the following example:

Refrigeration capacity request	Heat capacity request	
100%	0%	Production of refrigeration capacity only
100%	100%	Production of refrigeration capacity and Production of heat capacity using recovery
50%	100%	Production of refrigeration capacity and Production of heat capacity using recovery, equals 50% of the heat capacity request

- ⚠ To prevent constant switching in the unit's refrigeration circuit, it is necessary to install a storage tank with an adequate capacity in the system's hot water circuit.
- ⚠ In the absence of hot water circulating in the recovery exchanger, the maximum entering air temperature is reduced by approximately 2°C compared with the unit without "Total Energy Recovery" mode.

A - Total operating energy recovery

When hot water is requested, the condensing coil is deactivated. Condensation takes place wholly within the recovery circuit.

B - Total non-operating energy recovery

When the recovery set-point has been satisfied, the condensing coil is reactivated. In this condition, the total recovery circuit operates as a Partial recovery circuit (Desuperheater).

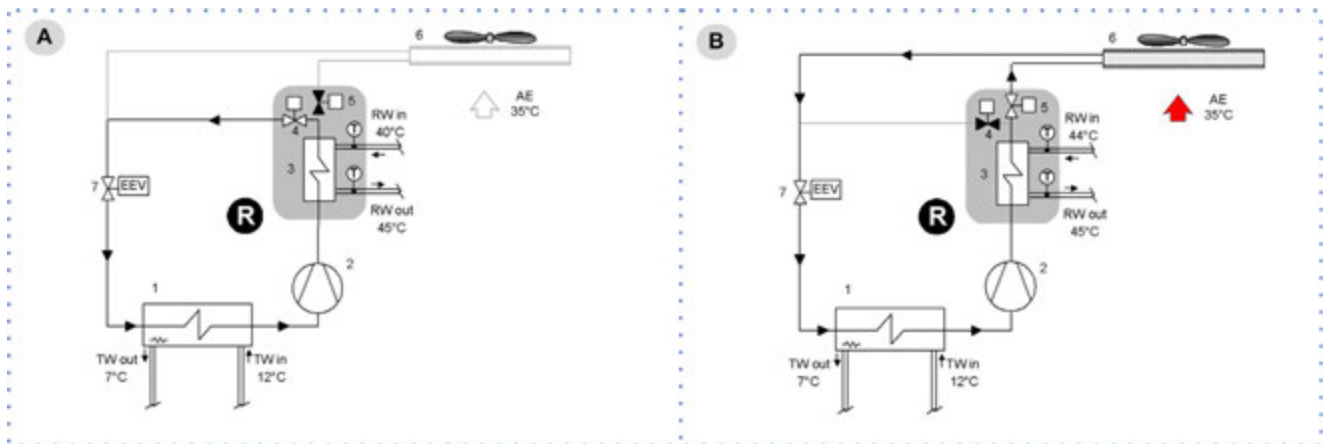

9.3 Partial energy recovery

A configuration which enables the production of hot water free-of-charge while operating in the cooling mode, thanks to the partial recovery of condensation heat that would otherwise be rejected to the external heat source.

The maximum capacity available from the partial recovery is equal to the 15% of the rejected heating capacity (cooling capacity + compressor power input)

When the temperature of the water to be heated is particularly low, it is wise to insert a flow-rate control valve into the system water circuit, in order to maintain the temperature at the recovery output at above 35°C and thus avoid the condensation of the refrigerant into the partial energy recovery device.

- ⚠ The recovery exchanger must be always maintained full of water
- The lack of water amplifies the noise generated by the operation

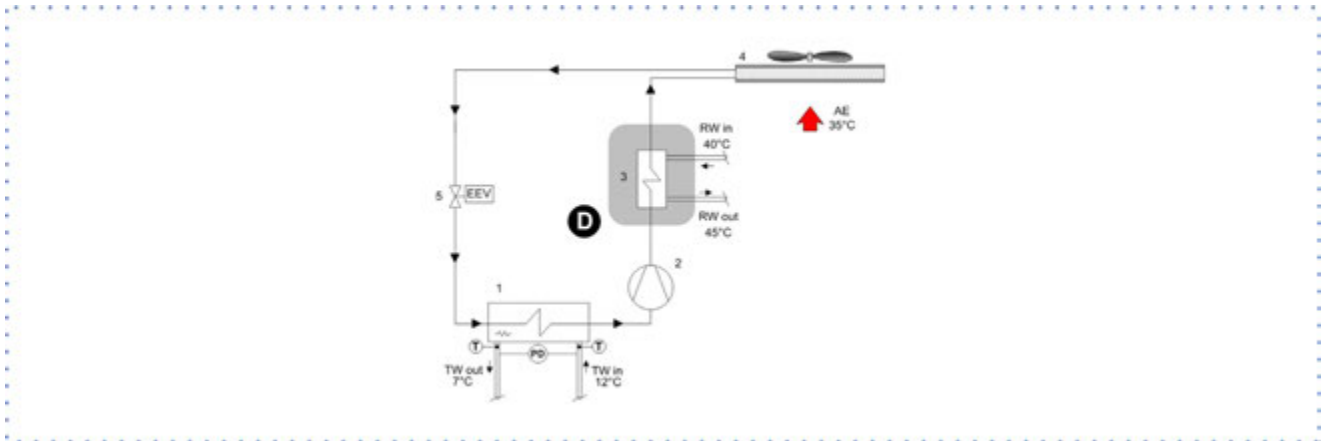

When the temperature of the water to be heated is particularly low, it is wise to insert a flow-rate control valve into the system water circuit, in order to maintain the temperature at the recovery output at above 35°C and thus avoid the condensation of the refrigerant into the partial energy recovery device.

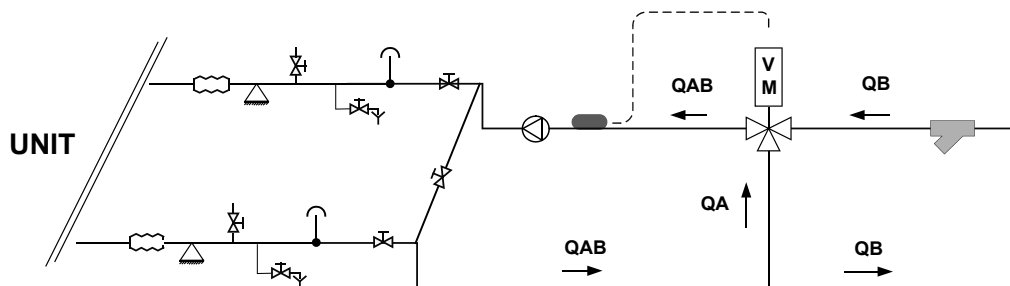

9.4 HydroPack

Pumping unit made up of two or three electropumps laid out in parallel, with auto-adaptive modular logic activation.

It enables the automatic reduction of the liquid flow rate in critical conditions, avoiding blocks due to overloading and consequential intervention work by specialised technical personnel.

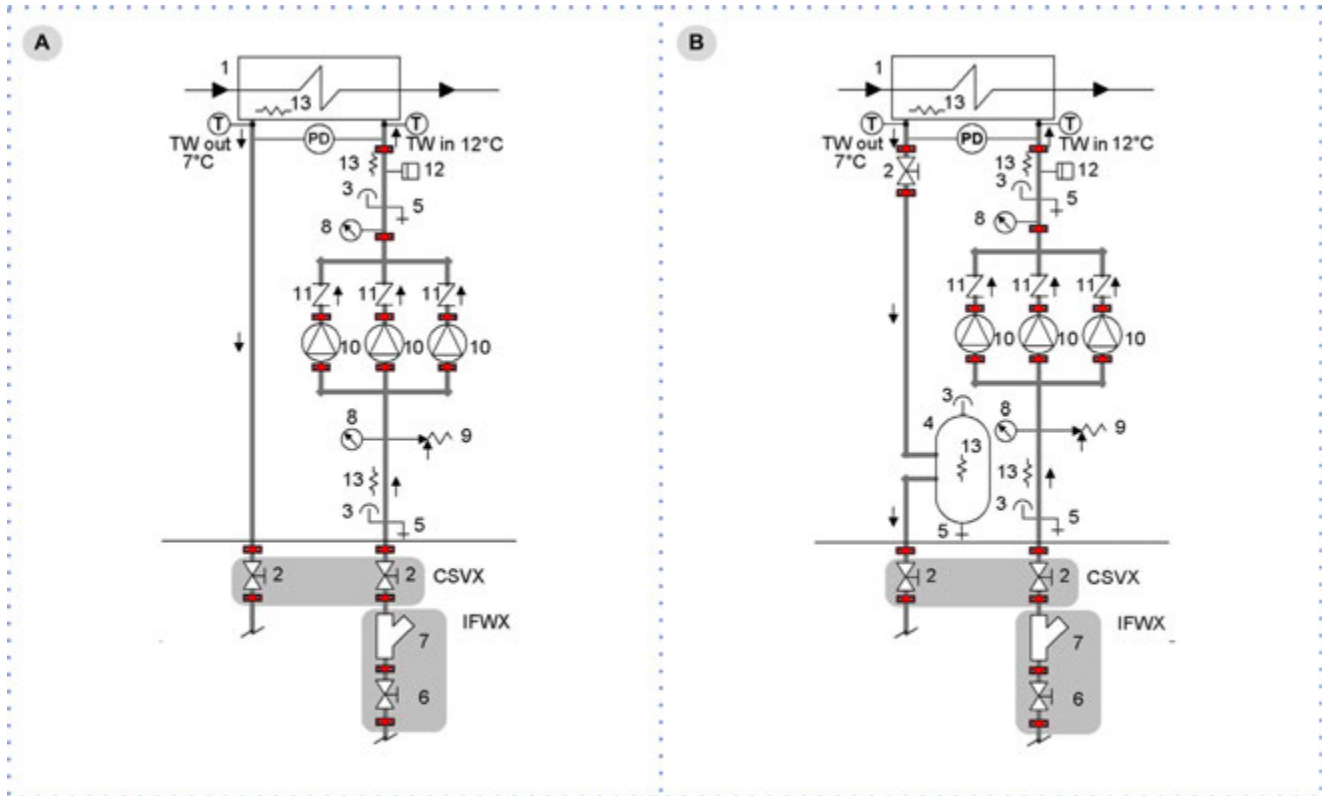

- 1 - Internal exchanger
- 2 - Cutoff valve
- 3 - Purge valve
- 4 - Storage tank
- 5 - Draw off cock
- 6 - Cutoff valve with quick joints
- 7 - Steel mesh strainer water side

- 8 - Manometer
- 9 - Safety valve (6 Bar)
- 10 - Packaged electric pump with high efficiency impeller activated by inverter
- 11 - Non return valve
- 12 - System safety pressure switch (prevents the pumps from operating if no water is present)
- 13 - Antifreeze heater
- T - Temperature probe

- PD - Differential pressure switch
- TW in chilled water inlet
- TW out chilled water outlet

IFWX = Steel mesh strainer water side

CSVX - Couple of manual shut-off valves

The grey area indicates further optional components.

9.5 Hydropack user side with 2 / 3 inverter pumps

Pumping unit consisting of parallel electric pumps and controlled by inverter to adapt to the different application conditions.

It enables the automatic reduction of the liquid flow rate in critical conditions, avoiding blocks due to overloading and consequential intervention work by specialised technical personnel.

Through the inverter calibration, standard supplied, it is possible to adapt the pump flow-rate/head to the installation feature.

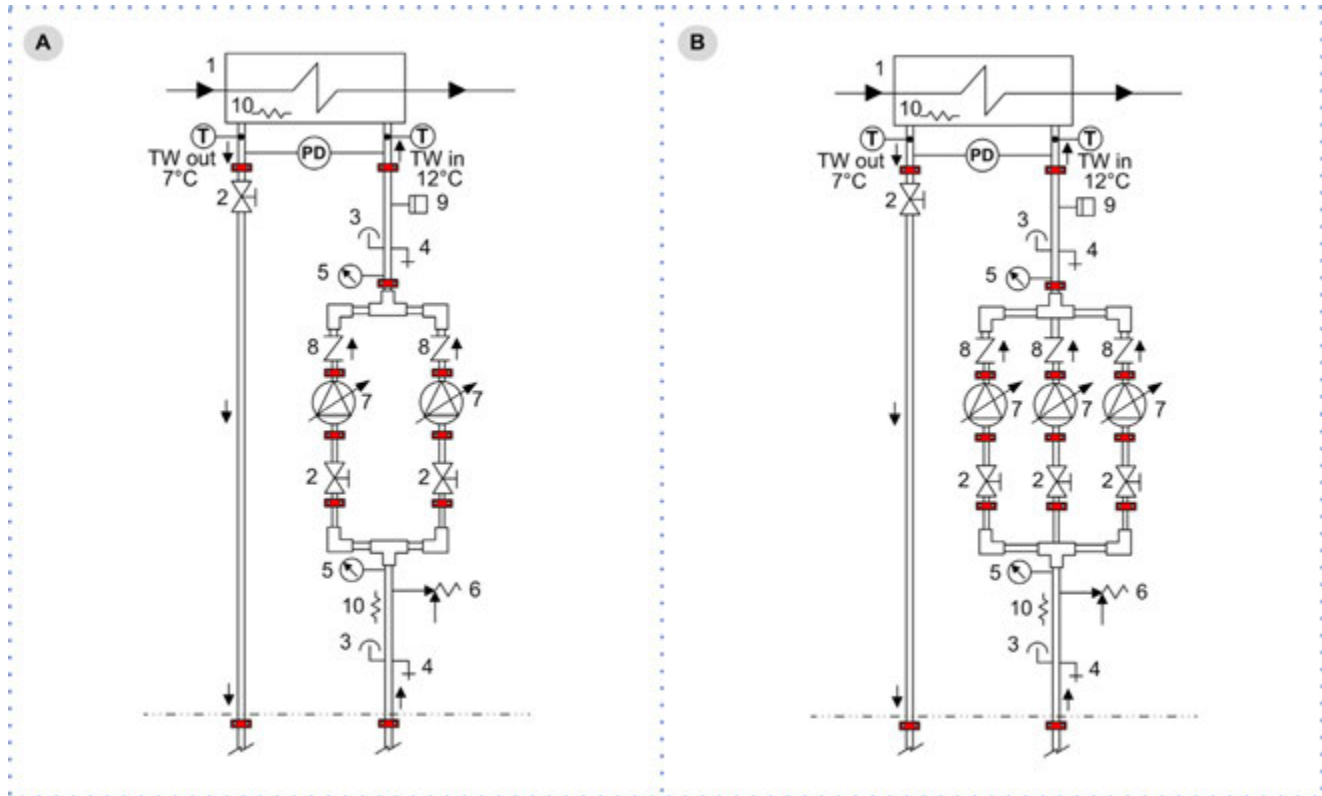

1 - Internal exchanger

2 - Cutoff valve

3 - Purge valve

4 - Draw off cock

5 - Manometer

6 - Safety valve (6 Bar)

7 - Packaged electric pump with high efficiency impeller activated by inverter

8 - Non return valve

9 - System safety pressure switch (prevents the pumps from operating if no water is present)

10 - Antifreeze heater

T - Temperature probe

PD - Differential pressure switch

TW in chilled water inlet

TW out chilled water outlet

10 Decommissioning

10.1 Disconnecting

Only authorised personnel must disconnect the unit.

Avoid leak or spills into the environment.

Before disconnecting the unit, the following must be recovered, if present:

- refrigerant gas
- anti-freeze solutions in the water circuit

Awaiting dismantling and disposal, the unit can also be stored outdoors, if the electrical, cooling and water circuits of the unit have 100% integrity and are isolated, bad weather and rapid change in temperature will not result in any environmental impact.

10.2 Dismantling and disposal

The unit must always be sent to authorised centres for dismantling and disposal.

When dismantling the unit, the fan, the motor and the coil, if operating, may be recovered by the specialist centres for reuse.

All the materials must be recovered or disposed of in compliance with the corresponding national standards in force.

For further information on the decommissioning of the unit, contact the manufacturer.

10.3 Directive EC RAEE

The manufacturer is registered on the EEE National Register, in compliance with implementation of Directive 2012/19/EU and relevant national regulations on waste electrical and electronic equipment.

This Directive requires electrical and electronic equipment to be disposed of properly.

Equipment bearing the crossed-out wheelee bin mark must be disposed of separately at the end of its life cycle to prevent damage to human health and to the environment.

Electrical and electronic equipment must be disposed of together with all of its parts.

To dispose of "household" electrical and electronic equipment, the manufacturer recommends you contact an authorised dealer or an authorised ecological area.

"Professional" electrical and electronic equipment must be disposed of by authorised personnel through established waste disposal authorities around the country.

In this regard, here is the definition of household WEEE and professional WEEE:

WEEE from private households: WEEE originating from private households and WEEE which comes from commercial, industrial, institutional and other sources which, because of its nature and quantity, is similar to that from private households. Subject to the nature and quantity, where the waste from EEE was likely to have been by both a private household and users of other than private households, it will be classed as private household WEEE;

Professional WEEE: all WEEE which comes from users other than private households.

This equipment may contain:

refrigerant gas, the entire contents of which must be recovered in suitable containers by specialised personnel with the necessary qualifications;

- lubrication oil contained in compressors and in the cooling circuit to be collected;
- mixtures with antifreeze in the water circuit, the contents of which are to be collected;
- mechanical and electrical parts to be separated and disposed of as authorised.

When machine components to be replaced for maintenance purposes are removed or when the entire unit reaches the end of its life and needs to be removed from the installation, waste should be separated by its nature and disposed of by authorised personnel at existing collection centres.



11 Residual risks

General description

In this section the most common situations are indicated, as these cannot be controlled by the manufacturer and could be a source of risk situations for people or things.

Danger zone

This is an area in which only an authorised operator may work.

The danger zone is the area inside the unit which is accessible only with the deliberate removal of protections or parts thereof.

Handling

The handling operations, if implemented without all of the protection necessary and without due caution, may cause the drop or the tipping of the unit with the consequent damage, even serious, to persons, things or the unit itself.

Handle the unit following the instructions provided in the present manual regarding the packaging and in compliance with the local regulations in force. Should the refrigerant leak please refer to the refrigerant "Safety sheet".

Installation

The incorrect installation of the unit could cause water leaks, condensate accumulation, leaking of the refrigerant, electric shock, poor operation or damage to the unit itself.

Check that the installation has been implemented by qualified technical personnel only and that the instructions contained in the present manual and the local regulations in force have been adhered to.

The installation of the unit in a place where even infrequent leaks of inflammable gas and the accumulation of this gas in the area surrounding the area occur could cause explosions or fires.

Carefully check the positioning of the unit.

The installation of the unit in a place unsuited to support its weight and/or guarantee adequate anchorage may result in consequent damage to things, people or the unit itself.

Carefully check the positioning and the anchoring of the unit.

Easy access to the unit by children, unauthorised persons or animals may be the source of accidents, some serious.

Install the unit in areas which are only accessible to authorised person and/or provide protection against intrusion into the danger zone.

General risks

Smell of burning, smoke or other signals of serious anomalies may indicate a situation which could cause damage to people, things or the unit itself.

Electrically isolate the unit (yellow-red isolator).

Contact the authorised service centre to identify and resolve the problem at the source of the anomaly.

Accidental contact with exchange batteries, compressors, air delivery tubes or other components may cause injuries and/or burns.

Always wear suitable clothing including protective gloves to work inside the danger zone.

Maintenance and repair operations carried out by non-qualified personnel may cause damage to persons, things or the unit itself.

Always contact the qualified assistance centre.

Failing to close the unit panels or failure to check the correct tightening of all of the panelling fixing screws may cause damage to persons, things or the unit itself.

Periodically check that all of the panels are correctly closed and fixed.

If there is a fire the temperature of the refrigerant could reach values that increase the pressure to beyond the safety valve with the consequent possible projection of the refrigerant itself or explosion of the circuit parts that remain isolated by the closure of the tap.

Do not remain in the vicinity of the safety valve and never leave the refrigeration system taps closed.

Electric parts

An incomplete attachment line to the electric network or with incorrectly sized cables and/or unsuitable protective devices can cause electric shocks, intoxication, damage to the unit or fires.

Carry out all of the work on the electric system referring to the electric layout and the present manual ensuring the use of a system thereto dedicated.

An incorrect fixing of the electric components cover may lead to the entry of dust, water etc inside and may consequently electric shocks, damage to the unit or fires.

Always fix the unit cover properly.

When the metallic mass of the unit is under voltage and is not correctly connected to the earthing system it may be as source of electric shock and electrocution.

Always pay particular attention to the implementation of the earthing system connections.

Contact with parts under voltage accessible inside the unit after the removal of the guards can cause electric shocks, burns and electrocution.

Open and padlock the general isolator prior to removing the guards and signal work in progress with the appropriate sign.

Contact with parts that could be under voltage due to the start up of the unit may cause electric shocks, burns and electrocution.

When voltage is necessary for the circuit open the isolator on the attachment line of the unit itself, padlock it and display the appropriate warning sign.

Moving parts

Contact with the transmissions or with the fan aspiration can cause injuries.

Prior to entering the inside of the unit open the isolator situated on the connection line of the unit itself, padlock and display the appropriate warning sign.

Contact with the fans can cause injury.

Prior to removing the protective grill or the fans, open the isolator on the attachment line of the unit itself, padlock it and display the appropriate warning sign.

Refrigerant

The intervention of the safety valve and the consequent expulsion of the gas refrigerant may cause injuries and intoxication.

Always wear suitable clothing including protective gloves and eyeglasses for operations inside the danger zone.

Should the refrigerant leak please refer to the refrigerant "Safety sheet".

Contact between open flames or heat sources with the refrigerant or the heating of the gas circuit under pressure (e.g. during welding operations) may cause explosions or fires.

Do not place any heat source inside the danger zone.

The maintenance or repair interventions which include welding must be carried out with the system off.

Hydraulic parts

Defects in tubing, the attachments or the removal parts may cause a leak or water projection with the consequent damages to people, things or shortcircuit the unit.

EXCELLENCE VERSION

Acoustic configuration: compressor soundproofing (SC)



General technical data - Performance

Size			90.4	100.4	110.4	120.4	140.4	160.4	180.4	200.4	220.4	240.4
Cooling												
Cooling capacity	1	[kW]	268	291	318	354	407	460	515	574	624	678
Compressor power input	1	[kW]	75	82	91	102	116	130	150	162	181	198
Total power input	2	[kW]	84,8	91,8	101	112	129	144	164	179	198	215
Partial recovery heating capacity	3	[kW]	68,6	74,6	81,7	91,2	105	118	133	147	161	175
Total recovery heating capacity	3	[kW]	325	356	391	440	501	562	643	704	775	846
EER	1	-	3,16	3,17	3,15	3,15	3,16	3,21	3,15	3,21	3,15	3,15
Water flow-rate (User Side)	1	[l/s]	12,8	13,9	15,2	16,9	19,4	22,0	24,6	27,4	29,8	32,4
Internal exchanger pressure drops	1	[kPa]	50	49	50	46	51	51	52	51	50	55
Cooling capacity (EN14511:2013)	4	[kW]	267	290	316	353	405	459	513	572	621	675
Total power input (EN14511:2013)	4	[kW]	85,8	92,9	102	114	130	145	165	181	200	218
EER (EN 14511:2013)	4	-	3,11	3,12	3,10	3,10	3,11	3,16	3,10	3,16	3,10	3,10
ESEER	4	-	4,31	4,37	4,35	4,35	4,40	4,54	4,51	4,40	4,38	4,44
Cooling capacity (AHRI 550/590)	5	[kW]	267	290	316	352	405	458	513	571	621	675
Total power input (AHRI 550/590)	5	[kW]	84,5	91,5	100,5	112,1	128,4	143,0	163,0	178,2	197,3	214,2
COP _R	5	-	3,16	3,16	3,15	3,14	3,16	3,21	3,15	3,21	3,15	3,15
IPLV	5	-	4,82	4,90	4,86	4,87	4,95	5,06	5,05	4,92	4,89	4,96

- Data referred to the following conditions: internal exchanger water = 12/7 °C. Entering external exchanger air temperature 35°C. Evaporator fouling factor = 0.44×10^{-4} m² K/W
- The Total Power Input value does not take into account the part related to the pumps and required to overcome the pressure drops for the circulation of the solution inside the exchangers
- Option. Recovery exchanger water=40/45°C
- Data compliant to Standard EN 14511:2013 referred to the following conditions: - Internal exchanger water temperature = 12/7°C - Entering external exchanger air temperature = 35°C
- Data compliant to Standard AHRI 550/590 referred to the following conditions: internal exchanger water temperature = 6,7 °C. Water flow-rate 0,043 l/s per kW. Entering external exchanger air temperature 35°C. Evaporator fouling factor = 0.18×10^{-4} m² K/W

PREMIUM VERSION

Acoustic configuration: compressor soundproofing (SC)



General technical data - Performance

Size			120.4	140.4	160.4	180.4	200.4	220.4	240.4
Cooling									
Cooling capacity	1	[kW]	334	381	423	492	531	596	648
Compressor power input	1	[kW]	109	125	140	159	174	193	210
Total power input	2	[kW]	118	135	149	171	186	208	226
Partial recovery heating capacity	3	[kW]	89,8	102	114	131	144	160	174
Total recovery heating capacity	3	[kW]	427	486	556	627	691	767	833
EER	1	-	2,81	2,84	2,83	2,86	2,84	2,85	2,86
Water flow-rate (User Side)	1	[l/s]	16,0	18,2	20,2	23,5	25,4	28,5	31,0
Internal exchanger pressure drops	1	[kPa]	55	53	55	58	55	55	54
Cooling capacity (EN14511:2013)	4	[kW]	333	379	421	490	529	594	645
Total power input (EN14511:2013)	4	[kW]	120	136	151	174	189	211	229
EER (EN 14511:2013)	4	-	2,77	2,80	2,78	2,82	2,80	2,81	2,82
ESEER	4	-	4,11	4,15	4,12	4,12	4,06	4,12	4,10
Cooling capacity (AHRI 550/590)	5	[kW]	332	379	420	489	528	592	644
Total power input (AHRI 550/590)	5	[kW]	118	134	149	171	186	208	225
COP _R	5	-	2,80	2,83	2,82	2,85	2,83	2,84	2,86
IPLV	5	-	4,59	4,65	4,64	4,63	4,55	4,60	4,60

- Data referred to the following conditions: internal exchanger water = 12/7 °C. Entering external exchanger air temperature 35°C. Evaporator fouling factor = 0.44×10^{-4} m² K/W
- The Total Power Input value does not take into account the part related to the pumps and required to overcome the pressure drops for the circulation of the solution inside the exchangers
- Option. Recovery exchanger water=40/45°C
- Data compliant to Standard EN 14511:2013 referred to the following conditions: - Internal exchanger water temperature = 12/7°C - Entering external exchanger air temperature = 35°C
- Data compliant to Standard AHRI 550/590 referred to the following conditions: internal exchanger water temperature = 6,7 °C. Water flow-rate 0,043 l/s per kW. Entering external exchanger air temperature 35°C. Evaporator fouling factor = 0.18×10^{-4} m² K/W

EXCELLENCE VERSION

Acoustic configuration: super-silenced (EN)

General technical data - Performance

Size			90.4	100.4	110.4	120.4	140.4	160.4	180.4	200.4	220.4	240.4
Cooling												
Cooling capacity	1	[kW]	259	280	307	341	393	438	491	549	599	642
Compressor power input	1	[kW]	78	85	95	108	120	136	160	170	191	210
Total power input	2	[kW]	85,1	92,1	102,1	115	130	146	169	182	203	222
Partial recovery heating capacity	3	[kW]	67,4	73,0	80,4	89,8	103,0	115,0	130,0	144,0	158,0	170,0
Total recovery heating capacity	3	[kW]	319	349	385	433	491	552	626	697	763	837
EER	1	-	3,04	3,04	3,01	2,96	3,03	3,01	2,90	3,02	2,96	2,90
Water flow-rate (User Side)	1	[l/s]	12,4	13,4	14,7	16,3	18,8	20,9	23,5	26,2	28,6	30,7
Internal exchanger pressure drops	1	[kPa]	47	46	47	43	48	46	47	47	46	49
Cooling capacity (EN14511:2013)	4	[kW]	258	279	306	340	392	436	489	547	597	640
Total power input (EN14511:2013)	4	[kW]	86,0	93,1	103	116	131	147	171	184	205	224
EER (EN 14511:2013)	4	-	3,00	3,00	2,96	2,92	2,99	2,97	2,86	2,98	2,92	2,86
ESEER	4	-	4,27	4,33	4,38	4,26	4,33	4,28	4,42	4,32	4,35	4,35
Cooling capacity (AHRI 550/590)	5	[kW]	257	278	305	339	391	435	488	546	595	638
Total power input (AHRI 550/590)	5	[kW]	84,9	91,8	102	115	129	145	169	181	202	221
COP _R	5	-	3,03	3,03	3,00	2,95	3,02	3,00	2,89	3,01	2,95	2,89
IPLV	5	-	4,8	4,87	4,92	4,78	4,83	4,79	4,93	4,83	4,87	4,85

- Data referred to the following conditions: internal exchanger water = 12/7 °C. Entering external exchanger air temperature 35°C. Evaporator fouling factor = 0.44×10^{-4} m² K/W
- The Total Power Input value does not take into account the part related to the pumps and required to overcome the pressure drops for the circulation of the solution inside the exchangers
- Option. Recovery exchanger water=40/45°C
- Data compliant to Standard EN 14511:2013 referred to the following conditions: - Internal exchanger water temperature = 12/7°C - Entering external exchanger air temperature = 35°C
- Data compliant to Standard AHRI 550/590 referred to the following conditions: internal exchanger water temperature = 6,7 °C. Water flow-rate 0,043 l/s per kW. Entering external exchanger air temperature 35°C. Evaporator fouling factor = 0.18×10^{-4} m² K/W

PREMIUM VERSION

Acoustic configuration: super-silenced (EN)

General technical data - Performance

Size			120.4	140.4	160.4	180.4	200.4	220.4	240.4
Cooling									
Cooling capacity	1	[kW]	322	365	405	471	504	573	614
Compressor power input	1	[kW]	114	130	146	166	185	202	221
Total power input	2	[kW]	121	137	153	175	194	213	233
Partial recovery heating capacity	3	[kW]	89,8	102	114	131	144	160	174
Total recovery heating capacity	3	[kW]	419	480	548	622	685	758	824
EER	1	-	2,66	2,66	2,64	2,69	2,59	2,68	2,64
Water flow-rate (User Side)	1	[l/s]	15,4	17,4	19,4	22,5	24,1	27,4	29,3
Internal exchanger pressure drops	1	[kPa]	50,9	49,1	50,6	52,9	49,5	51,1	48,5
Cooling capacity (EN14511:2013)	4	[kW]	321	364	403	469	502	571	612
Total power input (EN14511:2013)	4	[kW]	122	138	155	177	196	216	235
EER (EN 14511:2013)	4	-	2,62	2,63	2,61	2,65	2,56	2,65	2,61
ESEER	4	-	4,07	4,04	4,03	4,04	4,01	4,07	4,05
Cooling capacity (AHRI 550/590)	5	[kW]	320	363	402	468	501	569	610
Total power input (AHRI 550/590)	5	[kW]	121	137	153	175	194	213	232
COP _R	5	-	2,65	2,65	2,64	2,68	2,59	2,68	2,63
IPLV	5	-	4,54	4,53	4,50	4,52	4,50	4,57	4,52

- Data referred to the following conditions: internal exchanger water = 12/7 °C. Entering external exchanger air temperature 35°C. Evaporator fouling factor = 0.44×10^{-4} m² K/W
- The Total Power Input value does not take into account the part related to the pumps and required to overcome the pressure drops for the circulation of the solution inside the exchangers
- Option. Recovery exchanger water=40/45°C
- Data compliant to Standard EN 14511:2013 referred to the following conditions: - Internal exchanger water temperature = 12/7°C - Entering external exchanger air temperature = 35°C
- Data compliant to Standard AHRI 550/590 referred to the following conditions: internal exchanger water temperature = 6,7 °C. Water flow-rate 0,043 l/s per kW. Entering external exchanger air temperature 35°C. Evaporator fouling factor = 0.18×10^{-4} m² K/W

EXCELLENCE VERSION

Acoustic configuration: compressor soundproofing (SC)



General technical data - Construction

Size			90.4	100.4	110.4	120.4	140.4	160.4	180.4	200.4	220.4	240.4
Compressor												
Type of compressors		-	Scroll	Scroll	Scroll	Scroll	Scroll	Scroll	Scroll	Scroll	Scroll	Scroll
No. of compressors		Nr	4	4	4	4	4	4	4	4	4	4
Rated power (C1)		[HP]	45	50	55	60	70	80	90	100	100	120
Rated power (C2)		[HP]	45	50	55	60	70	80	90	100	120	120
Std Capacity control steps		-	6	6	6	4	6	4	6	6	6	4
Oil charge (C1)		[l]	10	11	13	13	13	13	13	13	13	13
Oil charge (C2)		[l]	10	11	13	13	13	13	13	13	13	13
Refrigerant charge (C1)	1	[kg]	26	33	33	33	44	44	50	54	55	65
Refrigerant charge (C2)	1	[kg]	25	32	32	32	42	43	49	53	61	63
Refrigeration circuits		-	2	2	2	2	2	2	2	2	2	2
Internal exchanger												
Type of internal exchanger	2	-	PHE	PHE	PHE	PHE	PHE	PHE	PHE	PHE	PHE	PHE
Water content		[l]	20	22	24	29	32	37	42	49	58	62
System water content	3	l	937	1196	1502	1819	1840	2367	1801	2359	2436	3483
External Section Fans												
Type of fans	4	-	AX	AX	AX	AX	AX	AX	AX	AX	AX	AX
Number of fans		Nr	6	6	6	6	8	8	8	10	10	10
Type of motor	5	-	AC/P	AC/P	AC/P	AC/P	AC/P	AC/P	AC/P	AC/P	AC/P	AC/P
Standard airflow		[l/s]	36628	36204	36187	34999	48272	46666	45657	58332	57703	57073
Connections												
Water fittings		-	4"	4"	4"	4"	4"	4"	5"	5"	5"	5"
Power supply												
Standard power supply		V	400/3~/50	400/3~/50	400/3~/50	400/3~/50	400/3~/50	400/3~/50	400/3~/50	400/3~/50	400/3~/50	400/3~/50
Electrical data												
FLA Total		A	205,5	216,5	233,3	262,1	299,3	328,3	379,7	416,9	457,1	497,3
FLI Total		kW	117,7	128,6	138,2	155,8	180,7	201,9	227,5	252,4	275,8	299,2
M.I.C. - Value	6	A	455,6	466,9	483,7	512,5	619,2	648,2	649,4	686,6	726,8	767,0
M.I.C. - with soft start accessory	6	A	317,8	329,1	345,9	374,7	447,2	476,2	649,4	686,6	726,8	767,0

- Indicative values for standard units with possible +/-10% variation. The actual data are indicated on the unit label
- PHE = plate exchanger
- Recommended system water content that does not consider the internal exchanger water content (evaporator). With outdoor air low temperature applications or low medium requested loads, the minimum installation water volume is obtained doubling the indicated value.
- AX = axial fan

- AC/P = asynchronous three-phase external rotor motor with phase cutting speed automatic control
Unbalance between phase max 2% Voltage variation: max +/- 10%
Electrical data refer to standard units; according to the installed accessories, the data can suffer some variations.
- M.I.C. = Maximum unit starting current.
The M.I.C. value is obtained adding the max. compressor starting current of the highest size to the power input at max. admissible conditions (F.L.A.) of the remaining electric components.

Sound levels

Size	Sound power level (dB)								Sound power level dB(A)	Sound pressure level dB(A)
	Octave band (Hz)									
	63	125	250	500	1000	2000	4000	8000		
90.4	93	90	90	88	88	85	71	62	92	72
100.4	93	90	90	88	88	85	71	62	92	72
110.4	93	90	90	88	88	85	71	62	92	72
120.4	93	90	90	88	88	85	71	62	92	72
140.4	94	91	91	89	89	86	72	63	92	72
160.4	95	92	92	90	90	87	73	64	93	73
180.4	101	97	96	93	89	84	78	72	95	74
200.4	101	97	96	93	89	84	78	72	95	74
220.4	102	98	97	94	90	85	79	73	95	74
240.4	102	98	97	94	90	85	79	73	95	75

The sound levels refer to standard unit with Axitop (no accessories) at full load, in test nominal conditions. The sound pressure level refers to 1 m. from the standard unit outer surface operating in open field.
Measures are according to UNI EN ISO 9614-2 regulations, with respect to the EUROVENT 8/1 certification, which provides for a tolerance of 3 dB(A) on the sound power level, which is the only acoustic data to be considered binding.

If unit is set without Axitop, the sound power level presents an increase up to 3 dB(A).

Data referred to the following conditions.
- internal exchanger water = 12/7 °C
- Ambient temperature = 35 °C

PREMIUM VERSION



Acoustic configuration: compressor soundproofing (SC)

General technical data - Construction

Size			120.4	140.4	160.4	180.4	200.4	220.4	240.4
Compressor									
Type of compressors		-	Scroll	Scroll	Scroll	Scroll	Scroll	Scroll	Scroll
No. of compressors		Nr	4	4	4	4	4	4	4
Rated power (C1)		[HP]	60	70	80	90	100	100	120
Rated power (C2)		[HP]	60	70	80	90	100	120	120
Std Capacity control steps		-	4	6	4	6	6	6	4
Oil charge (C1)		[l]	13	13	13	13	13	13	13
Oil charge (C2)		[l]	13	13	13	13	13	13	13
Refrigerant charge (C1)	1	[kg]	27	34	35	36	45	44	58
Refrigerant charge (C2)	1	[kg]	26	33	33	35	44	53	56
Refrigeration circuits		-	2	2	2	2	2	2	2
Internal exchanger									
Type of internal exchanger	2	-	PHE	PHE	PHE	PHE	PHE	PHE	PHE
Water content		[l]	24	29	32	37	42	49	58
System water content	3	l	1717	1723	2173	1720	2183	2327	3330
External Section Fans									
Type of fans	4	-	AX	AX	AX	AX	AX	AX	AX
Number of fans		Nr	6	6	6	8	8	10	10
Type of motor	5	-	AC/P	AC/P	AC/P	AC/P	AC/P	AC/P	AC/P
Standard airflow		[l/s]	37459	37103	36017	49946	49471	62135	60028
Connections									
Water fittings		-	4"	4"	4"	5"	5"	5"	5"
Power supply									
Standard power supply		V	400/3~/50	400/3~/50	400/3~/50	400/3~/50	400/3~/50	400/3~/50	400/3~/50
Electrical data									
FLA Total		A	262,1	291,1	320,1	379,7	408,7	457,1	497,3
FLI Total		kW	155,8	177,0	198,2	227,5	248,7	275,8	299,2
M.I.C. - Value	6	A	512,5	611,0	640,0	649,4	678,4	726,8	767,0
M.I.C. - with soft start accessory	6	A	374,7	439,0	468,0	649,4	678,4	726,8	767,0

- Indicative values for standard units with possible +/-10% variation. The actual data are indicated on the unit label
- PHE = plate exchanger
- Recommended system water content that does not consider the internal exchanger water content (evaporator). With outdoor air low temperature applications or low medium requested loads, the minimum installation water volume is obtained doubling the indicated value.
- AX = axial fan

- AC/P = asynchronous three-phase external rotor motor with phase cutting speed automatic control
Unbalance between phase max 2% Voltage variation: max +/- 10%
Electrical data refer to standard units; according to the installed accessories, the data can suffer some variations.
- M.I.C. = Maximum unit starting current.
The M.I.C. value is obtained adding the max. compressor starting current of the highest size to the power input at max. admissible conditions (F.L.A.) of the remaining electric components.

Sound levels

Size	Sound power level (dB)								Sound power level dB(A)	Sound pressure level dB(A)
	Octave band (Hz)									
	63	125	250	500	1000	2000	4000	8000		
120.4	93	90	90	88	88	85	71	62	92	72
140.4	94	91	91	89	89	86	72	63	92	72
160.4	95	92	92	90	90	87	73	64	93	73
180.4	101	97	96	93	89	84	78	72	95	74
200.4	101	97	96	93	89	84	78	72	95	74
220.4	102	98	97	94	90	85	79	73	95	74
240.4	102	98	97	94	90	85	79	73	95	75

The sound levels refer to standard unit with Axitop (no accessories) at full load, in test nominal conditions. The sound pressure level refers to 1 m. from the standard unit outer surface operating in open field.
Measures are according to UNI EN ISO 9614-2 regulations, with respect to the EUROVENT 8/1 certification, which provides for a tolerance of 3 dB(A) on the sound power level, which is the only acoustic data to be considered binding.
If unit is set without Axitop, the sound power level presents an increase up to 3 dB(A).

Data referred to the following conditions.
- internal exchanger water = 12/7 °C
- Ambient temperature = 35 °C

EXCELLENCE VERSION

Acoustic configuration: super-silenced (EN)

General technical data - Construction

Size			90.4	100.4	110.4	120.4	140.4	160.4	180.4	200.4	220.4	240.4
Compressor												
Type of compressors		-	Scroll	Scroll	Scroll	Scroll	Scroll	Scroll	Scroll	Scroll	Scroll	Scroll
No. of compressors		Nr	4	4	4	4	4	4	4	4	4	4
Rated power (C1)		[HP]	45	50	55	60	70	80	90	100	100	120
Rated power (C2)		[HP]	45	50	55	60	70	80	90	100	120	120
Std Capacity control steps		-	6	6	6	4	6	4	6	6	6	4
Oil charge (C1)		[l]	10	11	13	13	13	13	13	13	13	13
Oil charge (C2)		[l]	10	11	13	13	13	13	13	13	13	13
Refrigerant charge (C1)	1	[kg]	26	33	33	33	44	44	50	54	55	65
Refrigerant charge (C2)	1	[kg]	25	32	32	32	42	43	49	53	61	63
Refrigeration circuits		-	2	2	2	2	2	2	2	2	2	2
Internal exchanger												
Type of internal exchanger	2	-	PHE	PHE	PHE	PHE	PHE	PHE	PHE	PHE	PHE	PHE
Water content		[l]	20	22	24	29	32	37	42	49	58	62
System water content	3	l	937	1196	1502	1819	1840	2367	1801	2359	2436	3483
External Section Fans												
Type of fans	4	-	AX	AX	AX	AX	AX	AX	AX	AX	AX	AX
Number of fans		Nr	6	6	6	6	8	8	8	10	10	10
Type of motor	5	-	AC/P	AC/P	AC/P	AC/P	AC/P	AC/P	AC/P	AC/P	AC/P	AC/P
Standard airflow		[l/s]	30282	29943	29943	28704	39924	38272	37345	47841	47841	46681
Connections												
Water fittings		-	4"	4"	4"	4"	4"	4"	5"	5"	5"	5"
Power supply												
Standard power supply		V	400/3~/50	400/3~/50	400/3~/50	400/3~/50	400/3~/50	400/3~/50	400/3~/50	400/3~/50	400/3~/50	400/3~/50
Electrical data												
FLA Total		A	205,2	216,5	233,3	262,1	299,3	328,3	379,7	416,9	457,1	497,3
FLI Total		kW	117,7	128,6	138,2	155,8	180,7	201,9	227,5	252,4	275,8	299,2
M.I.C. - Value	6	A	455,6	466,9	483,7	512,5	619,2	648,2	649,4	686,6	726,8	767,0
M.I.C. - with soft start accessory	6	A	317,8	329,1	345,9	374,7	447,2	476,2	649,4	686,6	726,8	767,0

- Indicative values for standard units with possible +/-10% variation. The actual data are indicated on the unit label
- PHE = plate exchanger
- Recommended system water content that does not consider the internal exchanger water content (evaporator).
With outdoor air low temperature applications or low medium requested loads, the minimum installation water volume is obtained doubling the indicated value.
- AX = axial fan

- AC/P = asynchronous three-phase external rotor motor with phase cutting speed automatic control
Unbalance between phase max 2% Voltage variation: max +/- 10%
Electrical data refer to standard units; according to the installed accessories, the data can suffer some variations.
- M.I.C.=Maximum unit starting current.
The M.I.C. value is obtained adding the max. compressor starting current of the highest size to the power input at max. admissible conditions (F.L.A.) of the remaining electric components.

Sound levels

Size	Sound power level (dB)								Sound power level dB(A)	Sound pressure level dB(A)
	Octave band (Hz)									
	63	125	250	500	1000	2000	4000	8000		
90.4	87	84	84	82	82	79	65	56	86	66
100.4	87	84	84	82	82	79	65	56	86	66
110.4	87	84	84	82	82	79	65	56	86	66
120.4	88	85	85	83	83	80	66	57	86	66
140.4	88	85	85	83	83	80	66	57	86	66
160.4	89	86	86	84	84	81	67	58	87	67
180.4	96	92	91	88	84	79	73	67	90	69
200.4	96	92	91	88	84	79	73	67	90	69
220.4	97	93	92	89	85	80	74	68	90	69
240.4	97	93	92	89	85	80	74	68	90	70

The sound levels refer to standard unit with Axitop (no accessories) at full load, in test nominal conditions. The sound pressure level refers to 1 m. from the standard unit outer surface operating in open field.

Measures are according to UNI EN ISO 9614-2 regulations, with respect to the EUROVENT 8/1 certification, which provides for a tolerance of 3 dB(A) on the sound power level, which is the only acoustic data to be considered binding.

If unit is set without Axitop, the sound power level presents an increase up to 3 dB(A).

Data referred to the following conditions.

- internal exchanger water = 12/7 °C
- Ambient temperature = 35 °C

The indicated sound levels are only valid within the operating field of the standard unit at full load as indicated in the 'Operating range - cooling' graph in the "Super-silenced EN" configuration. With outdoor air temperatures the unit operates at full load automatically increasing the airflow and taking the same sound levels of the "Soundproofed Compressors SC" configuration.

PREMIUM VERSION

Acoustic configuration: super-silenced (EN)

General technical data - Construction

Size			120.4	140.4	160.4	180.4	200.4	220.4	240.4
Compressor									
Type of compressors		-	Scroll	Scroll	Scroll	Scroll	Scroll	Scroll	Scroll
No. of compressors		Nr	4	4	4	4	4	4	4
Rated power (C1)		[HP]	60	70	80	90	100	100	120
Rated power (C2)		[HP]	60	70	80	90	100	120	120
Std Capacity control steps		-	4	6	4	6	6	6	4
Oil charge (C1)		[l]	13	13	13	13	13	13	13
Oil charge (C2)		[l]	13	13	13	13	13	13	13
Refrigerant charge (C1)	1	[kg]	27	34	35	36	45	44	58
Refrigerant charge (C2)	1	[kg]	26	33	33	35	44	53	56
Refrigeration circuits		-	2	2	2	2	2	2	2
Internal exchanger									
Type of internal exchanger	2	-	PHE	PHE	PHE	PHE	PHE	PHE	PHE
Water content		[l]	24	29	32	37	42	49	58
System water content	3	l	1717	1723	2173	1720	2183	2327	3330
External Section Fans									
Type of fans	4	-	AX	AX	AX	AX	AX	AX	AX
Number of fans		Nr	6	6	6	8	8	10	10
Type of motor	5	-	AC/P	AC/P	AC/P	AC/P	AC/P	AC/P	AC/P
Standard airflow		[l/s]	30282	29943	28704	40376	39924	50471	47841
Connections									
Water fittings		-	4"	4"	4"	5"	5"	5"	5"
Power supply									
Standard power supply		V	400/3~/50	400/3~/50	400/3~/50	400/3~/50	400/3~/50	400/3~/50	400/3~/50
Electrical data									
FLA Total		A	262,1	291,1	320,1	379,7	408,7	457,1	497,3
FLI Total		kW	155,8	177,0	198,2	227,5	248,7	275,8	299,2
M.I.C. - Value	6	A	512,5	611,0	640,0	649,4	678,4	726,8	767,0
M.I.C. - with soft start accessory	6	A	374,7	439,0	468,0	649,4	678,4	726,8	767,0

- Indicative values for standard units with possible +/-10% variation. The actual data are indicated on the unit label
- PHE = plate exchanger
- Recommended system water content that does not consider the internal exchanger water content (evaporator). With outdoor air low temperature applications or low medium requested loads, the minimum installation water volume is obtained doubling the indicated value.
- AX = axial fan

- AC/P = asynchronous three-phase external rotor motor with phase cutting speed automatic control
Unbalance between phase max 2% Voltage variation: max +/- 10%
Electrical data refer to standard units; according to the installed accessories, the data can suffer some variations.
- M.I.C. = Maximum unit starting current.
The M.I.C. value is obtained adding the max. compressor starting current of the highest size to the power input at max. admissible conditions (F.L.A.) of the remaining electric components.

Sound levels

Size	Sound power level (dB)								Sound power level	Sound pressure level
	Octave band (Hz)									
	63	125	250	500	1000	2000	4000	8000	dB(A)	dB(A)
120.4	88	85	85	83	83	80	66	57	86	66
140.4	88	85	85	83	83	80	66	57	86	66
160.4	89	86	86	84	84	81	67	58	87	67
180.4	96	92	91	88	84	79	73	67	90	69
200.4	96	92	91	88	84	79	73	67	90	69
220.4	97	93	92	89	85	80	74	68	90	69
240.4	97	93	92	89	85	80	74	68	90	70

The sound levels refer to standard unit with Axitop (no accessories) at full load, in test nominal conditions. The sound pressure level refers to 1 m. from the standard unit outer surface operating in open field.

Measures are according to UNI EN ISO 9614-2 regulations, with respect to the EUROVENT 8/1 certification, which provides for a tolerance of 3 dB(A) on the sound power level, which is the only acoustic data to be considered binding.

If unit is set without Axitop, the sound power level presents an increase up to 3 dB(A).

Data referred to the following conditions.

- internal exchanger water = 12/7 °C
- Ambient temperature = 35 °C

The indicated sound levels are only valid within the operating field of the standard unit at full load as indicated in the 'Operating range - cooling' graph in the "Super-silenced EN" configuration. With outdoor air temperatures the unit operates at full load automatically increasing the airflow and taking the same sound levels of the "Soundproofed Compressors SC" configuration.

Operating range - Cooling

EXCELLENCE VERSION

Acoustic configuration: compressor soundproofing (SC)

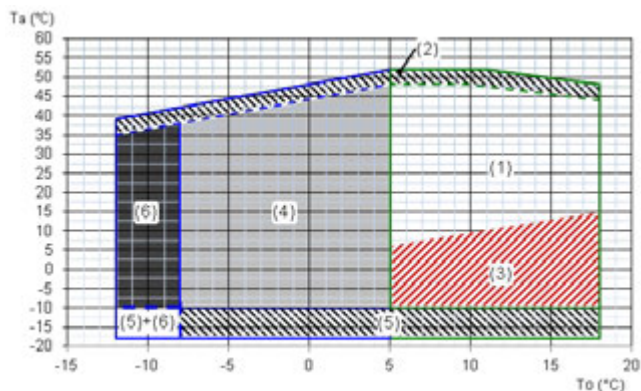

Acoustic configuration: super-silenced (EN)

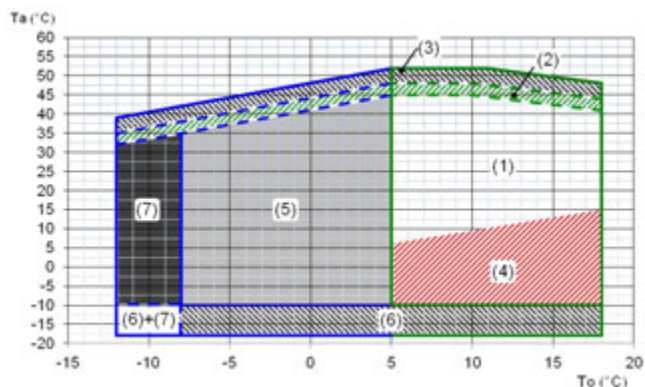

Ta (°C) = external exchanger inlet air temperature (D.B.)
To (°C) = internal exchanger outlet water temperature

1. Standard unit operating range at full load
2. Unit operating range with automatic staging of the compressor capacity
3. Standard unit operating range with air flow automatic modulation
4. Unit operating range in 'B - Low water temperature' configuration (40% ethylene glycol)
5. Unit operating range with 'REGBT - device for the condensing coil partialization'
6. Extended of operating range (extremely low water temperature option available on request)

Ta (°C) = entering external exchanger air temperature (D.B.)
To (°C) = leaving internal exchanger water temperature

1. Standard unit operating range at full load
2. Extended operating range with air flow-rate automatic increasing. Inside this field the sound levels are the same of the 'compressor soundproofing (SC)' acoustic configuration
3. Unit operating range with compressor capacity automatic partialization.
4. Standard unit operating range with air flow-rate automatic modulation
5. Operation field extension for unit in 'B - Low water temperature (Brine)' configuration (40% ethylene glycol)
6. Unit operating range with 'REGBT - device for the condensing coil partialization'
7. Extended of operating range (extremely low water temperature option available on request)

PREMIUM VERSION

Acoustic configuration: compressor soundproofing (SC)

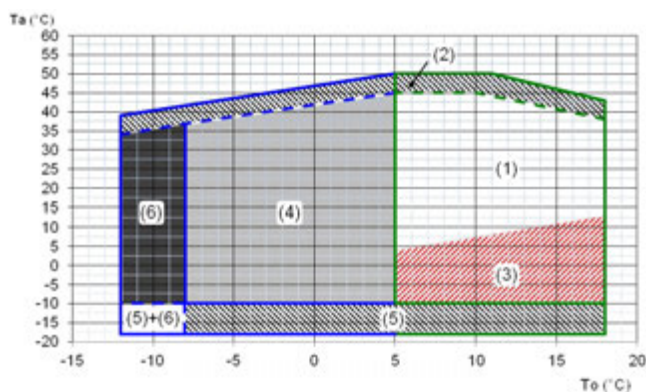

Acoustic configuration: super-silenced (EN)

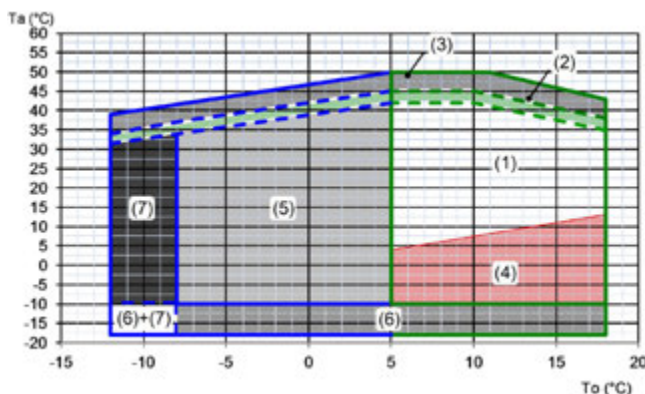

Ta (°C) = external exchanger inlet air temperature (D.B.)
To (°C) = internal exchanger outlet water temperature

1. Standard unit operating range at full load
2. Unit operating range with automatic staging of the compressor capacity
3. Standard unit operating range with air flow automatic modulation
4. Unit operating range in 'B - Low water temperature' configuration (40% ethylene glycol)
5. Unit operating range with 'REGBT - device for the condensing coil partialization'
6. Extended of operating range (extremely low water temperature option available on request)

Ta (°C) = entering external exchanger air temperature (D.B.)
To (°C) = leaving internal exchanger water temperature

1. Standard unit operating range at full load
2. Extended operating range with air flow-rate automatic increasing. Inside this field the sound levels are the same of the 'compressor soundproofing (SC)' acoustic configuration
3. Unit operating range with compressor capacity automatic partialization.
4. Standard unit operating range with air flow-rate automatic modulation
5. Operation field extension for unit in 'B - Low water temperature (Brine)' configuration (40% ethylene glycol)
6. Unit operating range with 'REGBT - device for the condensing coil partialization'
7. Extended of operating range (extremely low water temperature option available on request)

Admissible water flow-rates

Minimum (Qmin) and maximum (Qmax) admissible water flow for the unit to operate correctly.

EXCELLENCE SC / EN		90.4	100.4	110.4	120.4	140.4	160.4	180.4	200.4	220.4	240.4
Qmin	[l/s]	6,7	7,4	8,0	9,3	10,1	11,5	12,8	14,3	15,8	16,4
Qmax	[l/s]	18,3	20,0	21,8	25,1	27,5	31,2	34,5	38,6	42,4	44,0

PREMIUM SC / EN		120.4	140.4	160.4	180.4	200.4	220.4	240.4
Qmin	[l/s]	8,0	9,3	10,1	11,5	12,8	14,3	15,8
Qmax	[l/s]	21,8	25,1	27,5	31,2	34,5	38,6	42,4

Overload and control device calibrations

			open	closed	value
High pressure safety pressure switch		[kPa]	4050	3300	-
Antifreeze protection		[°C]	4	5.5	-
High pressure safety valve		[kPa]	-	-	4500
Low pressure safety valve		[kPa]	-	-	2950
Max no. of compressor starts per hour		[n°]	-	-	10
High compressor discharge temperature safety thermostat		[°C]	-	-	140

Exchanger operating range

	Internal exchanger		
	DPr		DPw
PED (CE)	4500	4500	1000

DPr = Maximum operating pressure on refrigerant side in kPa
 DPw = Maximum operating pressure on water side in kPa

Dimensional drawings

Size 90.4-120.4 - EXCELLENCE version - Size 120.4-160.4 - PREMIUM version

Acoustic configuration : Compressor soundproofing (SC) / Super-silenced (EN)

DAB8T90 4_120 4_EXC_PRM_SC_EN_1
Data/Date 04/08/2016

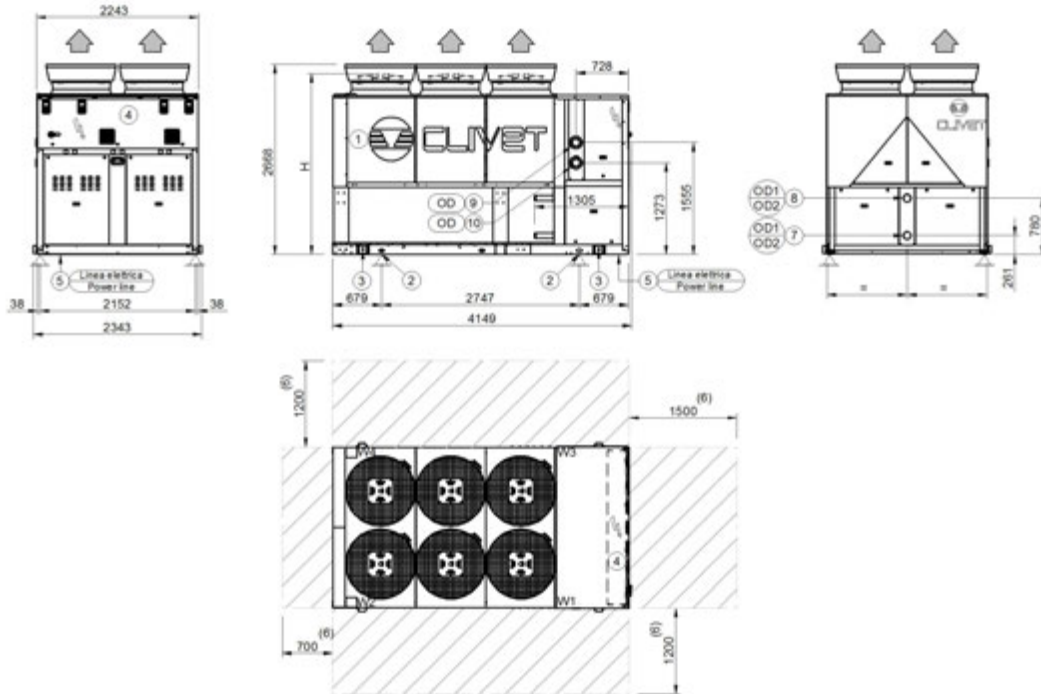

1. External exchanger (condenser)
2. Antivibration fixing holes \varnothing 25mm
3. Lifting brackets (removable, if required, after positioning the unit)
4. General electrical panel
5. Power input
6. Suggested clearance
7. Recovery side exchanger water inlet (optional)
8. Recovery side exchanger water outlet (optional)
9. Water inlet user side of no pumps unit / Water outlet user side of unit with pumps (optional)
10. Water outlet user side of no pumps unit / Water inlet user side of unit with pumps (optional)

Size		SC-EXC				SC-PRM			EN-EXC				EN-PRM		
		90.4	100.4	110.4	120.4	120.4	140.4	160.4	90.4	100.4	110.4	120.4	120.4	140.4	160.4
H (without Axitop)	mm	2484	2484	2484	2484	2484	2484	2484	2484	2484	2484	2484	2484	2484	2484
H (without Axitop with ECOBREEZE - optional)	mm	2510	2510	2510	2510	2510	2510	2510	2510	2510	2510	2510	2510	2510	2510
OD (internal exchanger)	mm	114,3	114,3	114,3	114,3	114,3	114,3	114,3	114,3	114,3	114,3	114,3	114,3	114,3	114,3
OD1 (partial recovery)	mm	76,1	76,1	76,1	76,1	76,1	76,1	76,1	76,1	76,1	76,1	76,1	76,1	76,1	76,1
OD2 (total recovery)	mm	114,3	114,3	114,3	114,3	114,3	114,3	139,7	114,3	114,3	114,3	114,3	114,3	114,3	139,7
A - Length	mm	4149	4149	4149	4149	4149	4149	4149	4149	4149	4149	4149	4149	4149	4149
B - Depth	mm	2243	2243	2243	2243	2243	2243	2243	2243	2243	2243	2243	2243	2243	2243
C - Height	mm	2668	2668	2668	2668	2668	2668	2668	2668	2668	2668	2668	2668	2668	2668
W1 Supporting point	kg	847	885	897	932	900	939	966	847	885	897	932	900	939	966
W2 Supporting point	kg	514	542	545	563	527	558	573	514	542	545	563	527	558	573
W3 Supporting point	kg	838	876	889	927	893	934	962	838	876	889	927	893	934	962
W4 Supporting point	kg	505	533	538	557	519	553	569	505	533	538	557	519	553	569
Shipping weight	kg	2594	2721	2754	2859	2721	2865	2948	2594	2721	2754	2859	2721	2865	2948
Operating weight	kg	2704	2836	2869	2979	2839	2984	3070	2704	2836	2869	2979	2839	2984	3070

Size		SC-EXC				SC-PRM			EN-EXC				EN-PRM		
		90.4	100.4	110.4	120.4	120.4	140.4	160.4	90.4	100.4	110.4	120.4	120.4	140.4	160.4
Container shipping length	mm	4300	4300	4300	4300	4300	4300	4300	4300	4300	4300	4300	4300	4300	4300
Container shipping depth	mm	2315	2315	2315	2315	2315	2315	2315	2315	2315	2315	2315	2315	2315	2315

The presence of optional accessories may result in a substantial variation of the weights shown in the table. Fan diffusers are separately supplied.

Size 140.4-180.4 - EXCELLENCE version - Size 180.4-200.4 - PREMIUM version

Acoustic configuration : Compressor soundproofing (SC) / Super-silenced (EN)

DAB8T140_4_180_4_EXC_PRM_SC_EN_2
Data / Date: 02/08/2016

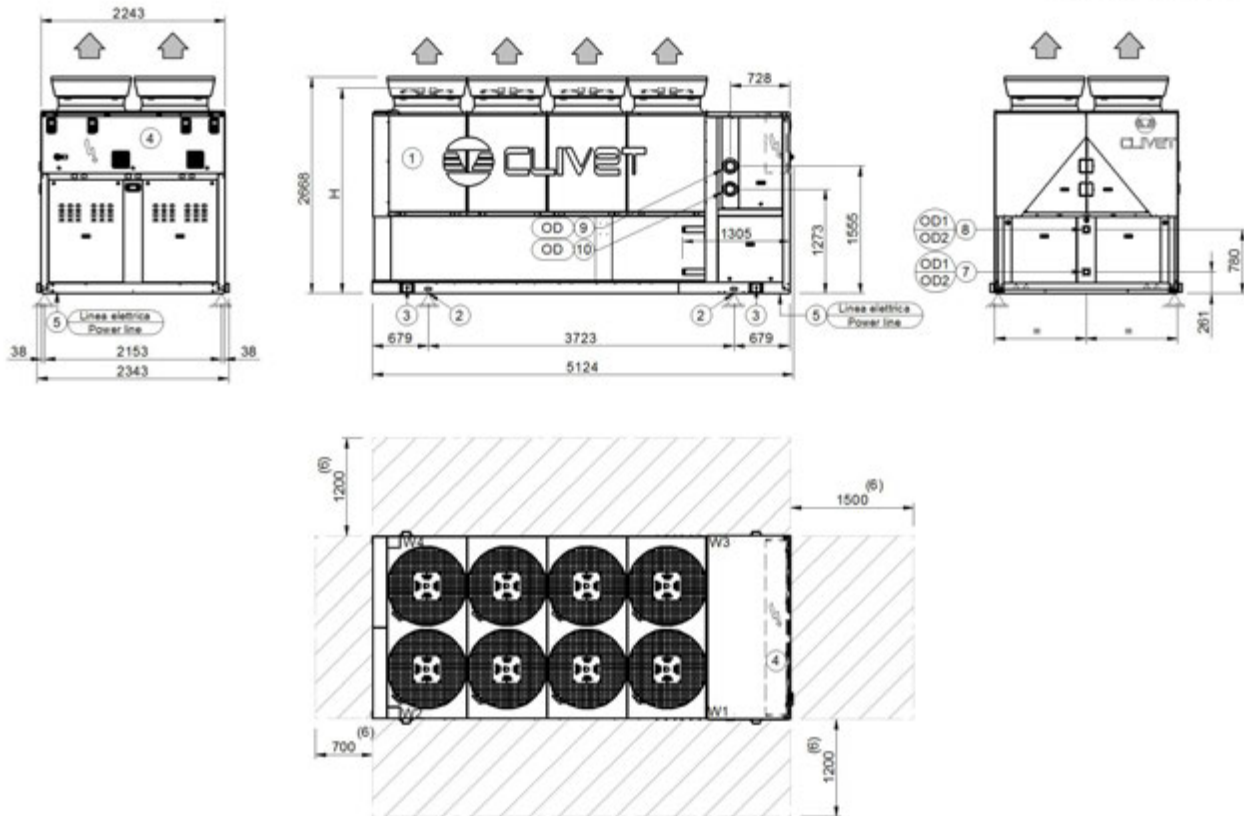

1. External exchanger (condenser)
2. Antivibration fixing holes \varnothing 25mm
3. Lifting brackets (removable, if required, after positioning the unit)
4. General electrical panel
5. Power input
6. Suggested clearance
7. Recovery side exchanger water inlet (optional)
8. Recovery side exchanger water outlet (optional)
9. Water inlet user side of no pumps unit / Water outlet user side of unit with pumps (optional)
10. Water outlet user side of no pumps unit / Water inlet user side of unit with pumps (optional)

Size		SC-EXC			SC-PRM			EN-EXC			EN-PRM	
		140.4	160.4	180.4	180.4	200.4	140.4	160.4	180.4	180.4	200.4	
H (without Axitop)	mm	2484	2484	2484	2484	2484	2484	2484	2484	2484	2484	
H (without Axitop with ECOBREEZE - optional)	mm	2510	2510	2510	2510	2510	2510	2510	2510	2510	2510	
OD (internal exchanger)	mm	114,3	114,3	114,3	114,3	139,7	114,3	114,3	114,3	114,3	139,7	
OD1 (partial recovery)	mm	76,1	76,1	76,1	76,1	76,1	76,1	76,1	76,1	76,1	76,1	
OD2 (total recovery)	mm	114,3	139,7	139,7	139,7	139,7	114,3	139,7	139,7	139,7	139,7	
A - Length	mm	5124	5124	5124	5124	5124	5124	5124	5124	5124	5124	
B - Depth	mm	2243	2243	2243	2243	2243	2243	2243	2243	2243	2243	
C - Height	mm	2668	2668	2668	2668	2668	2668	2668	2668	2668	2668	
W1 Supporting point	kg	1053	1083	1206	1139	1177	1053	1083	1206	1139	1177	
W2 Supporting point	kg	672	690	748	673	704	672	690	748	673	704	
W3 Supporting point	kg	1042	1074	1202	1132	1173	1042	1074	1202	1132	1173	
W4 Supporting point	kg	661	681	743	665	700	661	681	743	665	700	
Shipping weight	kg	3274	3371	3737	3453	3593	3274	3371	3737	3453	3593	
Operating weight	kg	3428	3528	3899	3609	3754	3428	3528	3899	3609	3754	

Size		SC-EXC			SC-PRM			EN-EXC			EN-PRM	
		140.4	160.4	180.4	180.4	200.4	140.4	160.4	180.4	180.4	200.4	
Container shipping length	mm	5275	5275	5275	5275	5275	5275	5275	5275	5275	5275	
Container shipping depth	mm	2315	2315	2315	2315	2315	2315	2315	2315	2315	2315	

The presence of optional accessories may result in a substantial variation of the weights shown in the table. Fan diffusers are separately supplied.

Size 200.4-240.4 - EXCELLENCE version - Size 220.4-240.4 - PREMIUM version

Acoustic configuration : Compressor soundproofing (SC) / Super-silenced (EN)

DAB8T200 4_240 4_EXC_PRM_SC_EN_1
Data/Date 04/08/2016

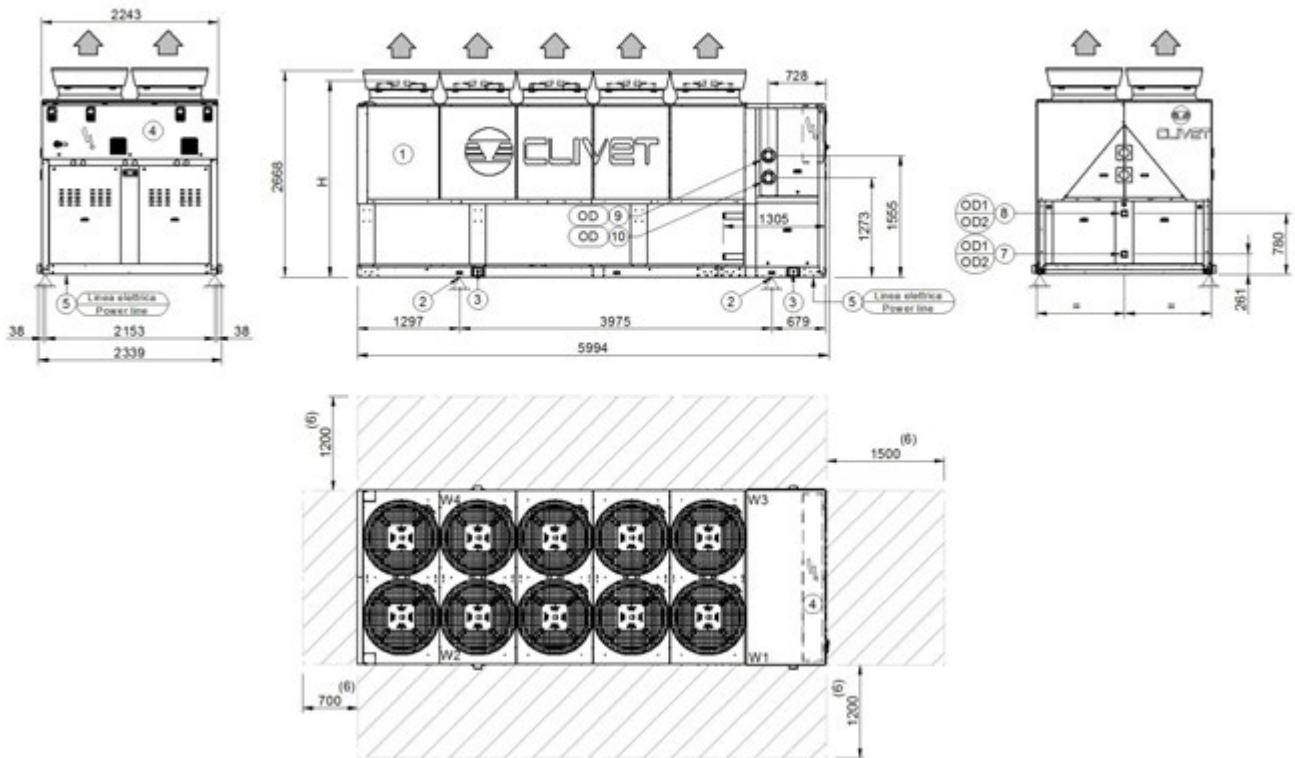

- 1. External exchanger (condenser)
- 2. Antivibration fixing holes \varnothing 25mm
- 3. Lifting brackets (removable, if required, after positioning the unit)
- 4. General electrical panel
- 5. Power input
- 6. Suggested clearance
- 7. Recovery side exchanger water inlet (optional)
- 8. Recovery side exchanger water outlet (optional)
- 9. Water inlet user side of no pumps unit / Water outlet user side of unit with pumps (optional)
- 10. Water outlet user side of no pumps unit / Water inlet user side of unit with pumps (optional)

Size		SC-EXC			SC-PRM		EN-EXC			EN-PRM	
		200.4	220.4	240.4	220.4	240.4	200.4	220.4	240.4	220.4	240.4
H (without Axitop)	mm	2484	2484	2484	2484	2484	2484	2484	2484	2484	2484
H (without Axitop with ECOBREEZE - optional)	mm	2510	2510	2510	2510	2510	2510	2510	2510	2510	2510
OD (internal exchanger)	mm	139,7	139,7	139,7	139,7	139,7	139,7	139,7	139,7	139,7	139,7
OD1 (partial recovery)	mm	76,1	76,1	76,1	76,1	76,1	76,1	76,1	76,1	76,1	76,1
OD2 (total recovery)	mm	139,7	139,7	139,7	139,7	139,7	139,7	139,7	139,7	139,7	139,7
A - Length	mm	5994	5994	5994	5994	5994	5994	5994	5994	5994	5994
B - Depth	mm	2243	2243	2243	2243	2243	2243	2243	2243	2243	2243
C - Height	mm	2668	2668	2668	2668	2668	2668	2668	2668	2668	2668
W1 Supporting point	kg	1331	1366	1414	1310	1376	1331	1366	1414	1310	1376
W2 Supporting point	kg	871	889	925	833	883	871	889	925	833	883
W3 Supporting point	kg	1321	1380	1413	1315	1372	1321	1380	1413	1315	1372
W4 Supporting point	kg	861	903	924	838	879	861	903	924	838	879
Shipping weight	kg	4185	4332	4468	4097	4305	4185	4332	4468	4097	4305
Operating weight	kg	4384	4538	4676	4296	4510	4384	4538	4676	4296	4510

Size		SC-EXC			SC-PRM		EN-EXC			EN-PRM	
		200.4	220.4	240.4	220.4	240.4	200.4	220.4	240.4	220.4	240.4
Container shipping length	mm	6145	6145	6145	6145	6145	6145	6145	6145	6145	6145
Container shipping depth	mm	2315	2315	2315	2315	2315	2315	2315	2315	2315	2315

The presence of optional accessories may result in a substantial variation of the weights shown in the table. Fan diffusers are separately supplied.

Page intentionally left blank

**CLIVET SPA**

Via Camp Lonc 25, Z.I. Villapaiera - 32032 Feltre (BL) - Italy
Tel. + 39 0439 3131 - Fax + 39 0439 313300 - info@clivet.it

CLIVET GROUP UK Limited

Units F5&F6 Railway Triangle Ind Est, Walton Road - Portsmouth, Hampshire - PO6 1TG - United Kingdom
Tel. + 44 (0) 1489 572238 - Fax. +44 (0) 2392 381243 - enquiries@clivetgroup.co.uk

CLIVET ESPAÑA S.A.U.

C/ Bac de Roda, 36 - 08019 Barcelona - España
Tel: +34 93 8606248 - Fax +34 93 8855392 - info@clivet.es

Av.Manoteras Nº 38, Oficina C303 - 28050 Madrid - España
Tel. +34 91 6658280 - Fax +34 91 6657806 - info@clivet.es

CLIVET GmbH

Hummelsbütteler Steindamm 84, 22851 Norderstedt - Germany
Tel. + 49 (0) 40 32 59 57-0 - Fax + 49 (0) 40 32 59 57-194 - info.de@clivet.com

CLIVET RUSSIA

Elektrozavodskaya st. 24, office 509 - 107023, Moscow, Russia
Tel. + 74956462009 - Fax + 74956462009 - info.ru@clivet.com

CLIVET MIDEAST FZCO

Dubai Silicon Oasis (DSO), High Bay Complex, Office N. 20, PO BOX 342009, Dubai, UAE
Tel. + 9714 3208499 - Fax + 9714 3208216 - info@clivet.ae

CLIVET AIRCONDITIONING SYSTEMS PRIVATE LIMITED

501/502, Commercial-1, Kohinoor City, Old Premier Compound, Kirol Road, Off L B S Marg, Kurla West - Mumbai 400 070 - India
Tel. +91 22 30930250 - info.in@clivet.com

www.clivet.com
www.clivetlive.com

A Group Company of

