



High efficiency air-cooled liquid chiller
air-cooled for outdoor installation

ELFOEnergy Large²

WSAT-XEE 352-802 RANGE



TECHNICAL BULLETIN



SIZE	352	402	432	452	502	552	602	702	802
COOLING CAPACITY [kW]	95,6	109	120	129	140	152	174	195	216



Clivet is taking part in the EUROVENT certification programme up to 1.500 kW. The products concerned appear in the certified products list of the EUROVENT www.eurovent-certification.com site.

Table of contents

Cost or reliability?.....	4
High efficiency hydronic systems.....	4
Clivet technological evolution.....	4
ELFOEnergy Large ²	5
Advantages.....	5
Comfort and energy saving in one solution.....	6
Efficient and silent ventilation technology	7
Two versions available for the various investment dynamics.....	8
Superior flexibility and reliability.....	9
The automatic control device coordinates resources ensuring maximum efficiency	10
ELFOEnergy Large ² technology industrialised the system	11
Efficient use of energy with heat recovery.....	13
Standard unit technical specifications	14
Technical features only for premium version.....	16
Excellence version (SC).....	17
Excellence version (EN).....	21
Premium version (SC).....	26
Premium version (EN)	30
Configurations.....	35
Accessories - hydronic assembly	41
HydroPack.....	46
Accessories	49
Accessories separately supplied	54
Correction factors for glycol use	55
Fouling Correction Factors.....	55
Overload and control device calibrations	55
Plate exchanger operating range.....	55
Option compatibility of Excellence version	56
Option compatibility of Premium version.....	57
Dimensional drawings: Excellence version	58
Dimensional drawings: Premium version.....	62

Cost or reliability?

The dilemma of modern system engineering applications

Air-conditioning systems in trade centres influence both the starting investment and monthly management costs, for the whole of their working lives. This theme is even more relevant in residential applications with centralised systems. Furthermore, maximum working flexibility requirements should be added to that, in serving different users while avoiding wasting energy and thus, money. Finally, there are several industrial applications which require hot or chilled water as service fluid, process fluid or vector fluid for operator comfort and for conserving goods and enabling cycles to function correctly. Furthermore, in all these cases, the working reliability of the system is decisive.



High efficiency hydronic systems

The high efficiency hydronic systems are extremely versatile, reliable and widespread

Despite their apparently low costs, split, multi-split and VRF direct expansion systems have a lot of limits in these applications. For example, they require a separate system for primary air treatment. The pipes that contain the refrigerant cross the served rooms and therefore they are subject to restrictions and use limitations. They cannot operate in the FREE-COOLING mode, the high efficiency and convenient mode that allows energy savings.

The hydronic systems are certainly more complete and versatile. They make it possible to adopt various types of terminals in the served environment, from fan coil units exposed or integrated in the furnishings, up to radiant or induction systems. They are also irreplaceable in the service and process industrial applications.

The main component performances, like air-cooled liquid chillers and hydronic heat pumps, are checked and certificated by appropriate certification programs, as Eurovent.



Clivet technological evolution

Clivet chillers reduce consumption and are compact and reliable

With over twenty years of technological evolution, Clivet liquid chillers and heat pumps represent the state of the art in air-conditioning of residential, trade and industrial environments.

Their success is based on high energy efficiency, compactness and management maintenance simplicity, with wide versatility in the choice of the most suitable model for the specific use.



ELFOEnergy Large²

Provides all Clivet technological developments for their medium capacity hydronic systems

High-efficiency Scroll compressors, high-performance heat exchangers, electronically-controlled fans, completely automatic functions: this is just some of the technology available in ELFOEnergy Large², in a range of models which are ideal for trade, residential and industrial medium capacity air-conditioning.

The two available versions allow to choose the best combination between the initial investment and the costs throughout the entire life cycle of the system.



- The EXCELLENCE SC version stands out for its extremely high energy efficiency under both part and full load conditions. (A- class Eurovent certification)
- The distinctive feature of the PREMIUM version is its compactness and high part-load efficiency.

Furthermore, ELFOEnergy Large² with its numerous configurations, can be completed with most common system options built-in.

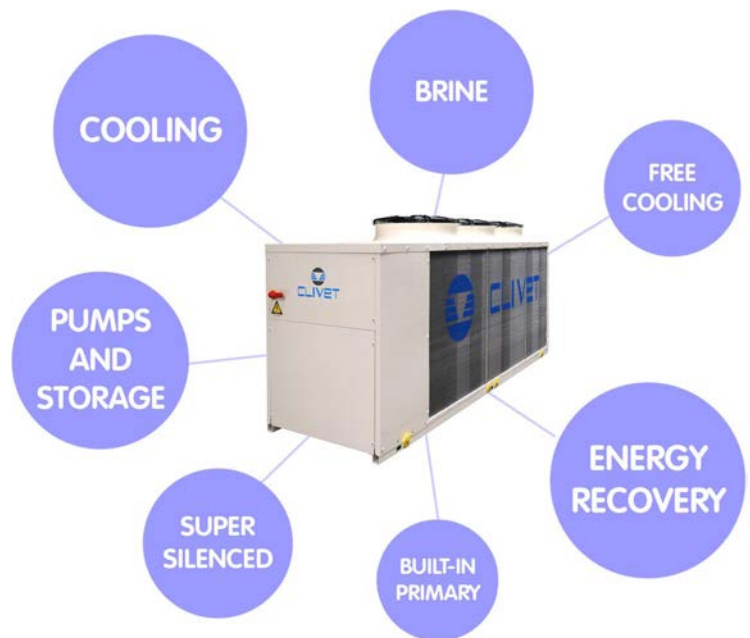

Advantages

High efficiency all year round

ELFOEnergy Large² reduces yearly energy consumption thanks to its high part-load efficiency i.e., by far the most frequent condition throughout the system's life-cycle. This way, even the value of the served building increases. The main components are manufactured on an industrial scale, with maximum manufacturing reliability and can be easily found as spare parts.

To further increase energy efficiency in a system with several ELFOEnergy Large² units operating on the same equipment, there is the innovative ECOSHARE feature, which automatically distributes the load and activates the necessary pumps.

4.3
ESEER
Seasonal
Efficiency

System simplification

All of the features are provided by Clivet already assembled and tested built-in, differently then other manufacturers who make numerous additional components available to be installed on site.

A
Energy
Class
Cooling

Compact and versatile

Suitable for any kind of terminal, from fan-coil unit to radiant systems and chilled beams, ELFOEnergy Large² is also available in supersilenced configuration, energy recovery to produce hot water free of charge, FREE-COOLING.

Comfort and energy saving in one solution

The maximum efficiency is between 25% and 75% of the system load

Maximum loads are checked only for a few operating hours per year. Therefore ELFOEnergy Large²'s high efficiency at partial loads makes it much more competitive and efficient than other solutions.

SYSTEM LOAD	WEIGHT (ESEER) *	WEIGHT (IPLV) *
100%	3%	1%
75%	33%	42%
50%	41%	45%
25%	23%	12%

*EUROVENT (ESEER) supply times reference and ARI (IPLV) reference for seasonal efficiency calculations.

The modular scroll is the excellent solution for partial load

ELFOEnergy Large² employs highly efficient Scroll compressors, with spirals optimised for this application.

The advantages are:

- Compressors manufactured in large numbers on an industrial scale, with strict quality checks and highest reliability thanks to the high scale mass production volumes.
- The two sizes of Scroll compressors allow for several control steps. This way, only the necessary energy is supplied.
- Efficiency increase that can exceed 50% of the operation with part load, thanks to the larger thermal exchange surfaces available.

The excellent performance is also given by the electronic expansion valve (EEV), which quickly and accurately adapts to the actual load requested by the application, along with the high-performance heat exchangers.



Very high heat exchange efficiency

Thanks to ELFOEnergy Large²'s external coils, with a wide front surface and reduced depth, one can obtain:

- Improved operating temperature of the cooling circuit and therefore greater efficiency, as the difference between the air's temperature and the temperature of the refrigerating fluid inside the exchanger is reduced
- Lower ventilation consumption, thanks to the reduced depth of the exchanger, which decreases pressure drops on the air flow. Moreover, the automatic fan speed control, provided as standard, minimises the air flow rate required for correct operation and therefore further reduces consumption
- Lower noise levels, as greater surfaces allow for slower speed of the air on the exchangers

Efficient and silent ventilation technology

Advanced aerofoil fans

The external axial fans are equipped with the innovative Winglet airfoil-vane with integrated baffle, able to increase the aerodynamic efficiency.

It results in a consumption reduction of the 10% and a medium sound emission lower of 6 dB than the traditional fans.

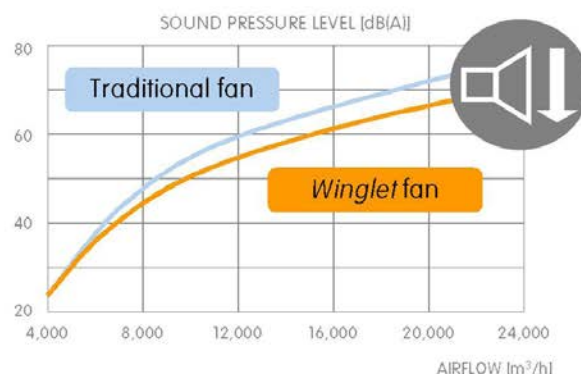
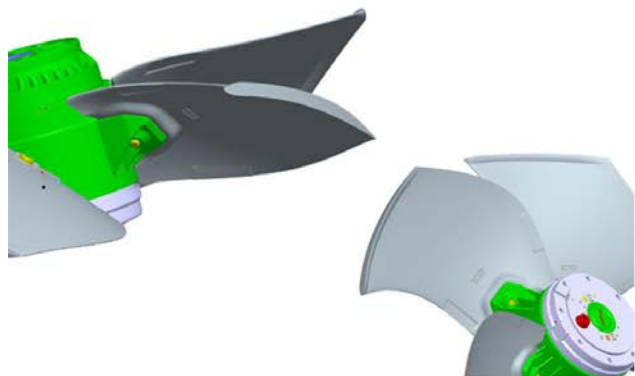

Electronic control ecobreeze technology

With ECOBREEZE, the electric motor with an external rotor is driven by the continuous magnetic switching of the stator, deriving from the integrated electronic control.

The advantages are:

- 70% increase in efficiency thanks to the brushless technology and the special electricity supply;
- Increase in the working life, thanks to the elimination of the brush wear;
- Reduction in the electrical consumption by the system, thanks to a drastic reduction of the inrush current for the fans obtained using the integrated 'Soft starter' function.



ECOBREEZE is supplied as standard in the excellence version

Fans at variable speed for minimal noise emission

All the ELFOEnergy Large² units fitted with ECOBREEZE fans are supplied with a condensation electronic control, which automatically reduces the fan speed as the heat load drops.

Since the fans are the unit's main noise source, the benefits are evident especially during the night hours, when the load is reduced but sensitivity to noise is enhanced.

All this translates into a reduction of sound pressure down to 8 dB(A) compared to full load operation in 90% of operating time of the unit.

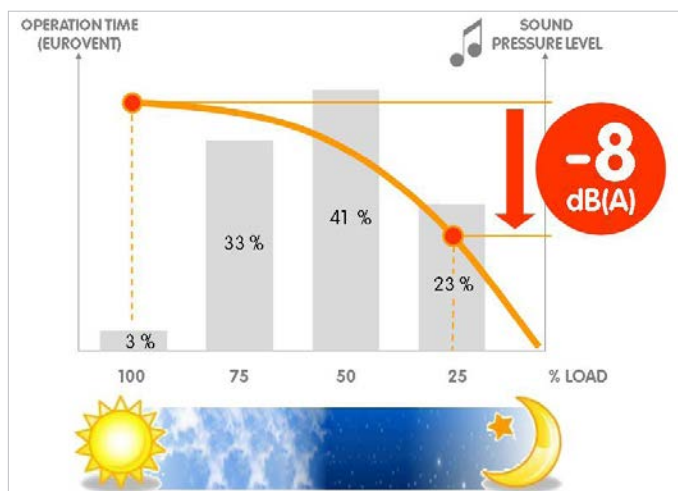

Two versions available for the various investment dynamics

Business oriented

All ELFOEnergy Large² models feature high part-load energy efficiency, which means high ESEER seasonal efficiency.

The two available versions allow to choose the best combination between the initial investment and the costs throughout the entire life cycle of the system.



Excellence version: maximum efficiency

Apart from the high seasonal efficiency, the standard EXCELLENCE SC version stands out for its extremely high energy efficiency ratio (EER) during full-load cooling, which exceeds the value 3.1 and places it in Eurovent Energy Efficiency class A.

This is all possible thanks to Scroll modular technology, high efficiency heat exchangers and ECOBREEZE fans fitted with a permanent-magnet motor and an electronic control device supplied as standard.

This allows for:

- Energy efficiencies equal to or higher than most units on the market equipped with screw compressors, even when inverter driven
- Efficient use even in a large number of industrial and process applications
- Upgrade of the building's energy class and, therefore, increased value
- Maximum savings on running and maintenance costs.

EXCELLENCE

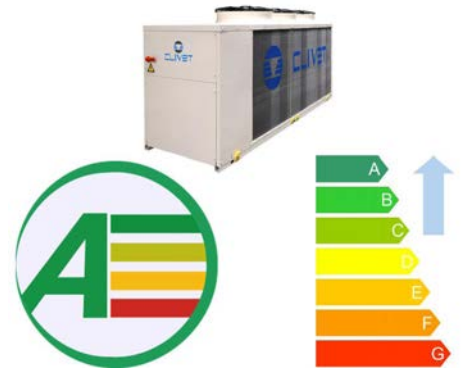

With Eurovent's implementation of the EN14511:2011 standard in 2012, reaching top energy efficiency levels at full load means calculating performance by also taking into account the energy consumption required to overcome pressure drops to allow for the circulation of the solution inside the exchangers.

Premium version: compact and aggressive

The optional PREMIUM version also develops excellent part-load efficiency, but features a compact design for the heat exchangers and structure. Therefore this solution is intended for applications that favour the initial investment rather than overall cost reduction throughout the lifespan of the system.



Superior flexibility and reliability

Efficient precision

The sequential activation logics of ELFOEnergy Large² compressors allow:

- accurately following the load heating/cooling, supplying better comfort;
- reducing the number of compressor start-ups which is the main cause for wear and tear
- increasing the life cycle of the unit
- reducing time and costs for any repairs, thanks to the modularity of components, their reduced dimensions and the lower cost compared to semi-hermetic compressors.

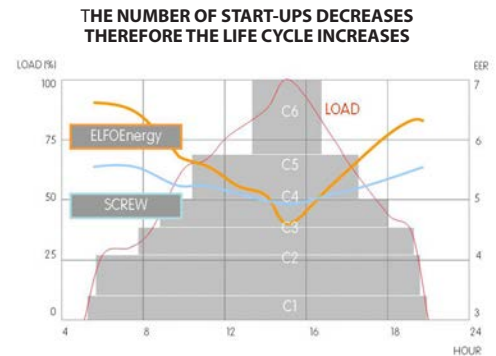

Stable and reliable operation

The electronic expansion valve (EEV) adapts rapidly and precisely to the actual load required for usage, allowing stable and reliable adjustment in comparison with mechanical thermostatic valves (TEV). This results also in a further increase in efficiency and longer compressor life.

The overheating control allows preventing phenomena that are hazardous to the compressors, such as overtemperature and return fluids, thereby increasing even more efficiency and durability.

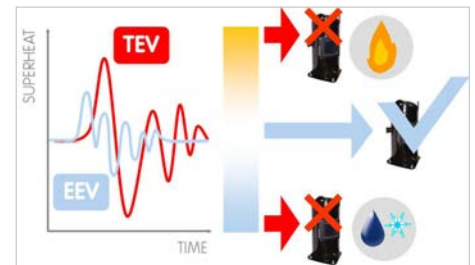

Simplified maintenance

Besides being efficient, ELFOEnergy Large² improves the system maintenance.

Indeed, the malfunction of a compressor does not compromise overall operation.

Moreover, Scroll compressors have a very compact design, are easy to find and easy to handle in case of replacements.



Practically unstoppable

ELFOEnergy Large² can operate even if the operation limits are temporarily exceeded. This occurs by increasing the fan speed at first and then passing to part-load condition (units equipped with ECOBREEZE fans).

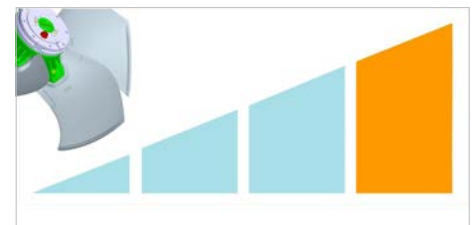

Controlled power supply

Proper power supply ensures optimal unit operation and protects its many electrical components.

The phase monitor, standard supplied in the EXCELLENCE and PREMIUM versions:

- controls the presence and the exact sequence of the phases
- checks any voltage anomalies (-10%)
- automatically restarts the unit as soon as the proper power supply is restored.

The EXCELLENCE version is fitted with a multifunction monitor, where limit values and the service schedule of Clivet's Technical Support can be modified.



The automatic control device coordinates resources ensuring maximum efficiency

Operating completely automatic

The microprocessor control automatically manages operation according to the maximum efficiency criterion and includes many safety and alarm management functions.

It also includes advanced functions, such as daily and weekly programming and automatic maximum power consumption limitation (demand limit).



Versatility

The various supply temperatures that can be set, make ELFOEnergy Large² perfectly suitable for various types of systems, such as:

- heat dissipation on water loop systems
- distribution to terminal units, such as fan coils or other air treatment units
- distribution to radiant panels, induction terminals or chilled beams

PERFECT FOR THE VARIOUS TYPES OF SYSTEMS



Modularity

In the event of particularly large buildings requiring high capacities, it is advisable to use several units.

The ELFOEnergy Large² units are designed to be connected in parallel in modular logic, thereby granting the following advantages:

- -increased flexibility, enhanced by the adjustment that can adapt to the load
- - increased reliability, since the malfunction of one unit does not compromise the capacity supply of the other units
- -increased efficiency, since energy is produced where and when required, according to the area served.

The microprocessor control combined with ECOSHARE allows controlling up to 7 units in local network (1 Master unit and 6 Slave).

ECOSHARE ENHANCES THE BENEFITS OF MODULAR SCROLL TECHNOLOGY

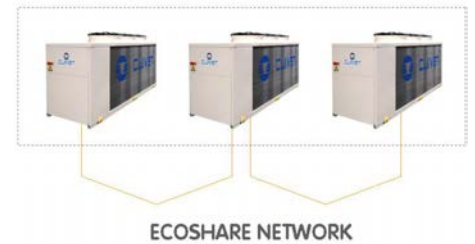

Remote system management

The unit is standard equipped with:

- potential-free contact for remote on-off control
- potential-free contacts for remote display of the compressor status
- settings from user interface Off / Local on / Serial on
- potential-free contact for the remote control of any alarms

The various communication protocols allow the unit to exchange information with the main supervision systems by means of serial connections.



ELFOEnergy Large² technology industrialised the system

ELFOEnergy Large² can be supplied equipped with components that are often separately provided.

So are reduced:

- design time: all the accessories are created to guarantee the best overall performance;
- installation costs: the accessories which are already mechanically connected, electrically wired and individually checked are ready to start operating immediately;
- overall dimensions: the integration of the unit in the system's parts reduces technical spaces and increases the available space for other uses. The lean structure allows to position it also in terraces or external service corridors.

Built-in inertial accumulation available

In most ELFOEnergy Large² systems it can be installed without inertial accumulation on the system.

The unit in fact adapts to the load very quickly, thanks to the compressor modularity, electronic thermostatic valve, plate exchangers at low water content.

However, in the event of hydraulic distribution networks with reduced dimensions, it is important to provide the system with an hydraulic flywheel. In such cases, inertial accumulation is available built-in, equipped with insulating coating and all the necessary safety devices. This allows eliminating installation times and costs and freeing space inside the building.



The built-in pumps are versatile, ready-for-use and reliable

The various solutions available are:

- Standard pump, with a wide range of available heads.
- Standard pump with standby pump. The built-in microprocessor balances its operating hours and in case of any breakdown signals the fault and automatically activates the standby pump.
- HYDROPACK, the modular solution with two parallel pumps. Automatically reduces water flow in critical conditions, avoiding blocks due to overloading and consequential interventions by specialised technical personnel. It is very useful during start-up, during re-start after a pause in working (e.g. a weekend) or after a long period of inactivity. In case of any pump breakdowns, the unit continues to function with 60% of the nominal flow.

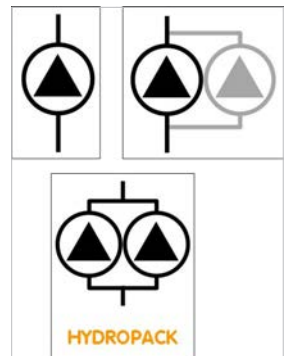

Even the primary circuit can be integrated built-in

A connection to the secondary use circuit is all that's needed. In this way, the system results even more simple and reliable.

The units are complete with quick connections on the hydraulic side, which further reduce start-up times by eliminating pipe threading operations.

Furthermore, other system components are also available as accessories, such as hydraulic connections reported on the external walls of the unit and the required water filter.

ELFOEnergy Large² MAY INCLUDE MOST OF SYSTEM COMPONENTS

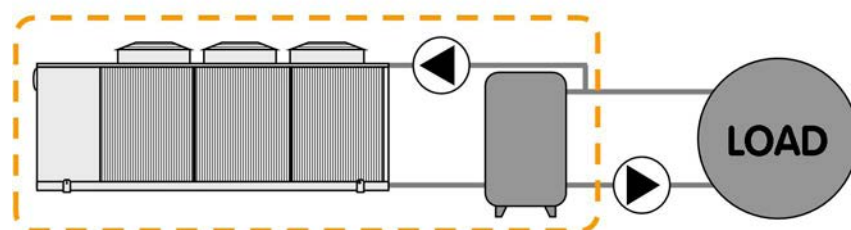

THE QUICK CONNECTIONS ARE STANDARD SUPPLIED

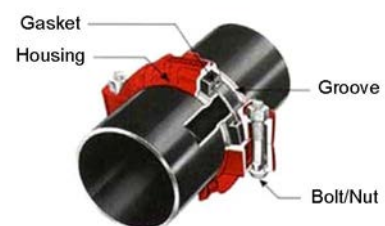

Produces hot water freely

Condensation heat recovery:

- Partial: it recovers about the 20% of the available heat (desuperheater)
- Total: it recovers the 100% of the available heat

It allows the free DHW production for:

- Hot water coil supply for reheat
- Domestic hot water production (with intermediate exchanger)
- Other processes or operations

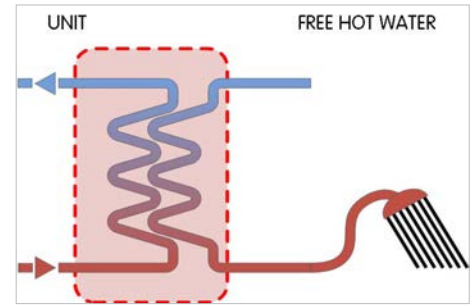

It exploits outdoor air for cooling without activating the compressors

In the FREE-COOLING configuration and as soon as the external conditions allow it, the unit can cool the liquid by reducing compressor operation until it is completely eliminated. This configuration is particularly useful in applications with a high number of room loads, since it significantly reduces the unit's energy consumption and wear of the compressors.

IN MANY PLACES THE WEATHER IS IDEAL FOR FREE-COOLING CONFIGURATION



FREE-COOLING

THE FREE-COOLING CONFIGURATION REDUCES COMPRESSOR OPERATION UNTIL ELIMINATING IT

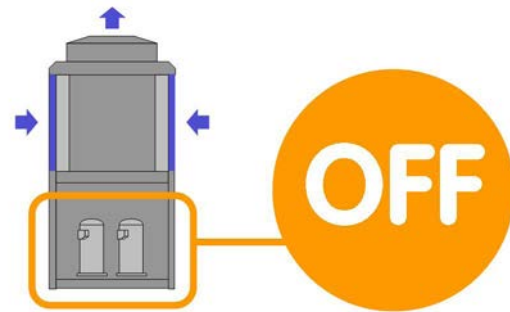

Even for low water temperature

The unit is also perfectly adapted for use in process cooling where the low temperature version (Brine) together with the addition of glycol to the thermo-vector liquid produces chilled water down to -7°C .



Demand limit

The partial or total activation of the compressors can be disabled to limit the overall electric capacity absorbed

The external signal is of analogical type 0-10 V / 4-20 mA. The greater the signal, the lower the capacity that the unit is enabled to deliver, activating the compressors and fans.

The Demand Limit function does not act on the control.



Efficient use of energy with heat recovery

In almost all systems fitted with a chiller used to produce chilled water there is also the need to have hot water. The recovery of condensation heat is an efficient way of producing hot water while the chiller is in operation. It has the double benefit of both reducing the heat load to the condenser, thereby eliminating dissipation costs and generating free hot water, thereby reducing the costs of the auxiliary heater.

Application versatility of recovery devices

The hot water produced by heat recovery can be used in a number of ways: to reheat air in handling units, to preheat hot water for domestic use or industrial processes, to heat up water in swimming pools, showers and spas, to preheat hot water for laundries or industrial kitchens.



Post-heating in air handling units to control humidity levels in hospitals and labs



Preheating of hot water for domestic use or for industrial process



Heating of water in swimming pools, showers and SPAS



Preheating of hot water for laundries and industrial kitchens

Water heating up

The heat recovery device can be used to cover the entire heat load required. The hot water supply temperature is controlled via a modulating control valve that needs to be fitted on the system at the outlet of the recovery unit. The auxiliary heating device is recommended to cover the thermal energy demand when the chiller is not in operation or is operating at part load.

Example of how heat recovery is used to cover the entire heat demand and control the operating temperature

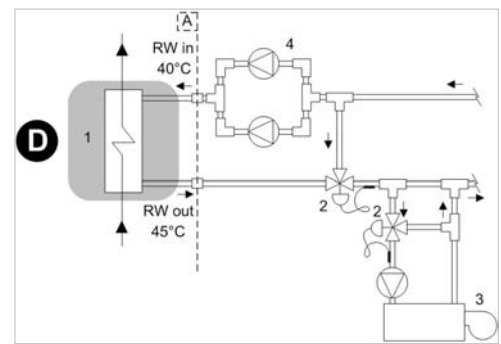

Water preheating

The heat recovery device can be used to preheat water at the inlet of the main heating device (e.g. boiler). In this case, the demand for hot water is greater than the amount of heat recovered by condensation and the recovery device only covers part of the required heat load. By preheating the water, heating consumption levels are therefore reduced and the main heating device has a lower installed power requirement.

Example of how heat recovery is used to preheat hot water in the system

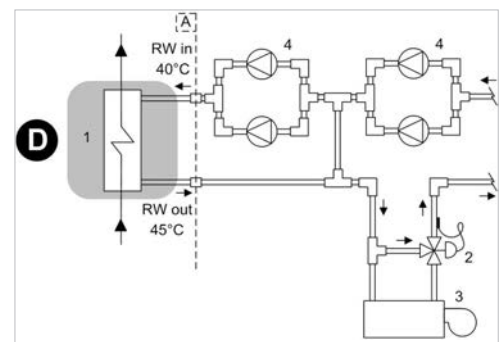

Domestic hot water production

The heat recovery device can be used to produce water for domestic use. In order to prevent contamination of domestic water with the chiller's process fluid, it is necessary to insert an intermediate heat exchanger. Using an inertial heat storage tank allows to have a reserve of preheated water and enables the intermediate exchanger to operate more efficiently.

Example of how heat recovery is used to preheat hot water for domestic use

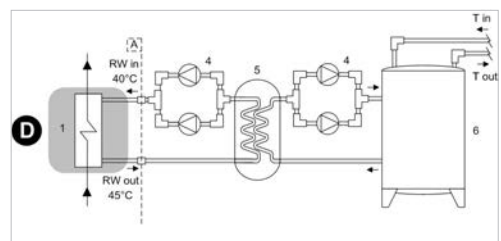

- A - Unit supply limit
- 1 - Recovery exchanger
- 3 - Auxiliary heating device (ex.boiler)
- 5 - Intermediate heat exchanger
- RW in - Recovery water input
- T in - Drinkable water inlet

- D - Partial energy recovery
- 2 - Control modulating valve
- 4 - Electric pump with standby pump
- 6 - Inertial heat storage
- RW out - Recovery water output
- T out - Drinkable water outlet to the auxiliary heater

The diagrams refer to partial energy recovery, though they also apply to total energy recovery (Clivet R). Please note that the diagrams are only meant as a guide.

Standard unit technical specifications

Compressor

Hermetic orbiting scroll compressor complete with motor over-temperature and over-current devices and protection against excessive gas discharge temperature. Fitted on rubber antivibration mounts and complete with oil charge.

An oil heater, which starts automatically, keeps the oil from being diluted by the refrigerant when the compressor stops.

The compressors are connected in TANDEM on a single refrigerating circuit. They have a biphasic oil equalisation and are equipped with supply on/off valve.

Structure

The bearing structure is made from hot-galvanized and painted plate and the external panelling from pre-painted aluminium (RAL9001), ensuring maximum weatherability. The uniform unit weight distribution is guaranteed by the base structure, realized with galvanized and painted plate section bars, featuring holes and/or brackets to simplify the unit lifting and earthing.

The entire structure has been sized with modern calculation tools and finished elements to ensure the maximum safety and sturdiness of the system.

Load-bearing structure made with hot-galvanized and painted sheet metal with external pre-painted (RAL9001) aluminium panelling to ensure top resistance against the elements. The even distribution of the machine's weight is ensured by the base's structure, made with galvanized and painted sheet metal profiles with holes and/or brackets that allow to easily lift and place the unit on the ground.

Panelling

External pre-painted aluminium panelling that ensures superior resistance to corrosion for outdoor installation and eliminates the need for periodical painting. The panels can be easily removed to fully access internal components and are lined with sound-proof material on the inside to contain the unit's sound levels.

Internal exchanger

Direct expansion heat exchanger with braze welded stainless steel INOX AISI 316 plates and complete with external thermal/anti-condensation insulation.

The exchanger is complete with:

- differential pressure switch, water side
- antifreeze heater to protect the water side exchanger, preventing the formation of frost if the water temperature falls below a set value.

External exchanger

Direct expansion finned coil exchanger made with copper pipes placed on staggered rows mechanically expanded to better adhere to the fin collar. The fins are made from aluminium with a corrugated surface and adequately distanced to ensure the maximum heat exchange efficiency.

Correct power supply to the expansion valve is ensured by the under-cooling circuit.

Protective coverings available on request.

Fan

ECOBREEZE device (STD)

Axial fans with sickle profile blades terminating with winglets, directly coupled to the electronic controlled motor (IP54), driven by the magnetic commutation of the stator. The brushless technology and the special supply increase both the life expectancy and the efficiency. As a result the electric consumption is reduced up to 50%. Fans are housed in aerodynamically shaped structures to increase efficiency and reduce noise level. The assembly is protected by accident prevention guards.

Supplied with variable speed control.

Refrigeration circuit

Refrigeration circuit with:

- replaceable anti-acid solid cartridge dehydrator filter
- sight glass with moisture and liquid indicator
- electronic expansion valve
- high pressure safety pressure switch
- low pressure safety switch
- high pressure safety valve
- low pressure safety valve

Electrical panel

The capacity section includes:

- main door lock isolator switch
- isolating transformer for auxiliary circuit power supply
- compressor circuit breakers
- fan overload circuit breakers
- compressor control contactor

The control section includes:

- interface terminal with graphic display
- display of the set values, the error codes and the parameter index
- ON/OFF and alarm reset buttons
- Proportional-integral-derivative water temperature control
- daily, weekly programmer of temperature set-point and unit on/off
- unit switching on management by local or remote (serial)
- antifreeze protection water side
- compressor overload protection and timer
- prealarm function for water anti-ice and high refrigerant gas pressure
- self-diagnosis system with immediate display of the error code
- automatic compressor start rotation control
- compressor operating hour display
- Input for remote ON/OFF control
- Input for remote HEAT/COOL control
- relay for remote cumulative fault signal
- inlet for demand limit (power input limitation according to a 0÷10V external signal)
- digital input for double set-point enabling
- potential-free contacts for compressor status
- multifunction phase monitor

Configurations

D - Partial energy recovery

R - Totale energy recovery

B - Low water temperature

SC - Acoustic configuration with compressor soundproofing

EN - Extremely low noise acoustic configuration

FCD - direct FREE-COOLING

Accessories - hydronic assembly

- standard pump (n.b.: other types are available by head)
- standard pump with standby pump (n.b.: other types are available by head)
- HYDROPACK (n.b.: other types are available by head)
- storage tank
- storage tank with primary circuit built-in the unit (n.b.: only for units complete with a Standard pump / Standard pump with a standby pump).
- steel mesh mechanical strainer (accessory separately provided). Note: To be located at the exchanger inlet. We disclaim any liability and make the guarantee void, if an appropriate mechanical filter is not provided inside the system.

Accessories

- finned coil protection grill
- anti-hail protection grilles
- copper / aluminium condensing coil with acrylic lining
- copper/copper condensing coil with Energy Guard DCC Aluminum treatment
- high and low pressure gauges
- cutoff valve on compressor supply and return
- electrical panel ventilation
- electrical panel antifreeze protection
- multifunction phase monitor (Premium Version only)
- power factor correction capacitors (cos ϕ > 0.9)
- ECOSHARE function for the automatic management of a group of units
- breakaway current reducing device (SOFT STARTER)
- serial communication module for BACnet supervisor
- serial communication module for MODBUS supervisor
- serial communication module for LonWorks supervisor
- device for consumption reduction of the external section at variable speed (phase-cutting) (only for EXCELLENCE version)
- remote control via microprocessor remote control (accessory separately supplied)
- mains power supply unit (accessory separately supplied)
- energy meter
- set-point compensation with signal 0-10 V
- set-point compensation with outdoor air temperature probe
- spring antivibration mounts (supplied separately)

On request are available:

- copper / copper condensing coils with brass shoulders

Test

All the units are factory-tested in specific steps, before shipping them. After the approval, the moisture contents present in all circuits are analyzed, in order to ensure the respect of the limits set by the manufacturers of the different components.

Technical features only for premium version

Same technical features of the EXCELLENCE version, except for the non-ECOBREEZE fans and the phase monitor, which has a fixed setting (optional multifunction version).

Fan

Helical fans with sickle blades with "Winglets" at the tip, directly coupled to the three-phase external rotor electrical motor, with incorporated thermal protection made of IP54. The fans are housed in aerodynamically-shaped nozzles to increase efficiency and minimise sound levels, they are equipped with safety grilles and supplied with variable speed control.

Excellence version (SC)

General technical data (SC)

Acoustic configuration: compressor soundproofing (SC)

Size			352	402	432	452	502	552	602	702	802
Cooling											
Cooling capacity	1	kW	96,0	109	121	129	141	152	175	196	217
Compressor power input	1	kW	27,4	31,6	35,4	36,2	40,3	44,1	50,9	56,0	63,2
Total power input	2	kW	30,2	34,4	38,3	40,3	44,5	48,3	55,0	61,4	68,6
Total recovery heating capacity	3	kW	119	139	151	161	176	190	215	242	269
Partial recovery heating capacity	3	kW	31,2	35,3	39,0	41,7	45,8	49,7	56,1	63,2	70,2
EER	1		3,17	3,18	3,15	3,21	3,17	3,16	3,18	3,18	3,17
Cooling capacity (EN14511:2013)	4	kW	95,6	109	120	129	140	152	174	195	216
Total power input (EN14511:2013)	4	kW	30,7	34,8	38,8	40,9	45,0	49,0	55,8	62,3	69,6
EER (EN 14511:2013)	4		3,12	3,13	3,10	3,15	3,12	3,10	3,12	3,13	3,11
SEER	8		4,12	4,24	4,11	4,22	4,17	4,11	4,14	4,22	4,10
Compressor											
Type of compressors			SCROLL	SCROLL	SCROLL	SCROLL	SCROLL	SCROLL	SCROLL	SCROLL	SCROLL
No. of compressors		No	2	2	2	2	2	2	2	2	2
Rated power (C1)		HP	35	40	43	45	50	55	60	70	80
Std Capacity control steps		No	3	3	3	3	3	3	2	3	2
Oil charge (C1)		l	8,00	10,0	12,0	10,0	11,0	13,0	13,0	13,0	13,0
Refrigerant charge (C1)	5	kg	28	28	32	39	39	39	45	51	58
Refrigeration circuits		No	1	1	1	1	1	1	1	1	1
Internal exchanger											
Type of internal exchanger	6		PHE	PHE	PHE	PHE	PHE	PHE	PHE	PHE	PHE
Water flow rate (Utility Side)	1	l/s	4,60	5,20	5,80	6,20	6,70	7,30	8,40	9,30	10,4
Internal exchanger pressure drops	1	kPa	30,0	29,9	30,2	35,0	34,3	39,8	40,3	41,3	41,3
Water content		l	6,90	8,00	8,90	8,90	10,1	10,1	11,9	14,2	17,2
Min installation water contents	9	l	422	403	545	361	508	699	963	921	1215
External Section Fans											
Type of fans	7		AX	AX	AX	AX	AX	AX	AX	AX	AX
Number of fans		No	2	2	2	3	3	3	3	4	4
Standard air flow		l/s	12327	12248	12182	18373	18373	18216	18102	24227	24069
Connections											
Water connections			2" 1/2	2" 1/2	2" 1/2	2" 1/2	2" 1/2	2" 1/2	2" 1/2	2" 1/2	2" 1/2
Power supply											
Standard power supply		V	400/3/50	400/3/50	400/3/50	400/3/50	400/3/50	400/3/50	400/3/50	400/3/50	400/3/50
Dimensions											
A - Length		mm	3075	3075	3075	4025	4025	4025	4025	5025	5025
B - Width		mm	1097	1097	1097	1097	1097	1097	1097	1097	1097
C - Height		mm	1805	1805	1805	1805	1805	1805	1805	1805	1805
Standard unit weights											
Shipping weight		kg	889	925	1015	1198	1224	1246	1290	1483	1527
Operating weight		kg	896	933	1024	1207	1234	1256	1302	1497	1544

The Product is compliant with the Erp (Energy Related Products) European Directive. It includes the Commission delegated Regulation (EU) No 2016/2281, also known as Ecodesign LOT21.

Contains fluorinated greenhouse gases(GWP 2087,5)

1. Data referred to the following conditions: Internal exchanger water temperature = 12 / 7 °C. External exchanger inlet air temperature = 35 °C
2. The Total Power Input value does not take into account the part related to the pumps and required to overcome the pressure drops for the circulation of the solution inside the exchangers
3. Option. Recovery exchanger water = 40/45 °C
4. Data calculated in compliance with Standard EN 14511:2013 referred to the following conditions: Internal exchanger water temperature = 12/7 °C. External exchanger intake air temperature = 35 °C
5. Indicative values for standard units with possible +/-10% variation. The actual data are indicated on the label of the unit.
6. PHE = plates
7. AX = axial fan
8. Data calculated according to the EN 14825:2016 Regulation
9. The calculated water volume to the system does not consider the volume of water contained in the internal exchanger. With applications at low outdoor air temperature or low average loads requested, the minimum water volume to the system is obtained by increasing the indicated value by 40%.

Electrical data (SC)

Acoustic configuration: compressor soundproofing (SC)

Size		352	402	432	452	502	552	602	702	802
F.L.A. - Full load current at max admissible conditions										
F.L.A. - Total	A	76,1	84,5	94,2	102,9	108,6	117	131,4	150	164,5
F.L.I. - Full load power input at max admissible conditions										
F.L.I. - Total	kW	44,2	49,0	56,6	60,0	65,4	70,2	79,0	91,8	102,4
M.I.C. Maximum inrush current										
M.I.C. - Value	A	264,6	311,6	321,3	353,7	359,3	367,7	382,1	470,2	484,7

Voltage unbalance: max 2 %
Power supply: 400/3/50 Hz +/- 10%

Electrical data refer to standard units; according to the installed accessories, the data can suffer some variations.

Operating range - Cooling (SC)

Acoustic configuration: compressor soundproofing (SC)

Size			352	402	432	452	502	552	602	702	802
External exchanger											
Max inlet air temperature	1	°C	47	46	46	47	47	46	46	47	46
Max inlet air temperature	2	°C	50	50	50	50	50	50	50	50	50
Min. inlet air temperature	3	°C	-10	-10	-10	-10	-10	-10	-10	-10	-10
Min. inlet air temperature	4	°C	-7,0	-7,0	-7,0	-7,0	-7,0	-7,0	-7,0	-7,0	-7,0
Min. inlet air temperature	5	°C	-2,0	-2,0	-2,0	-2,0	-2,0	-2,0	-2,0	-2,0	-2,0
Min. inlet air temperature	6	°C	11	11	11	11	11	11	11	11	11
Internal exchanger											
Max inlet water temperature		°C	24	24	24	24	24	24	24	24	24
Min. outlet water temperature	7	°C	5,0	5,0	5,0	5,0	5,0	5,0	5,0	5,0	5,0
Min. outlet water temperature	8	°C	-7,0	-7,0	-7,0	-7,0	-7,0	-7,0	-7,0	-7,0	-7,0

Data referred to the following conditions:
- internal exchanger water = 12/7°C
- air at rest

Caution: Air conditions which are at rest are defined as the absence of air flowing towards the unit. Weak winds can induce air to flow through the exchanger and air-levels which can cause a reduction in the operating range. In the presence of predominant winds it is necessary to use suitable windbreak barriers.

N.B. To ensure the correct maintenance (no operation) with outdoor air temperatures less than -10°C, the Standard unit (no FREE-COOLING configuration) must be equipped with the "Electrical panel anti-freeze protection" option and continue to be supplied with power. The hydraulic circuit must be filled with an adequate percentage of anti-

freeze. In these conditions, the minimum outdoor air temperature which is permitted depends on the model of the "Electrical panel anti-freeze protection" option which has been chosen, up to a limit value of -39°C. The operating mode can also be extended up to an outdoor air temperature of -25°C, but only in the FREE-COOLING configuration which is complete with an "Electrical panel anti-freeze protection" option of an adequate size. The operating mode can be further extended to external air temperatures of 39°C. Only in the full FREE-COOLING configuration of the Device to reduce consumption of external section fans operating at variable speed (phase cut) and 'Electrical panel antifreeze protection' of an adequate size. In the Standard unit (no FREE-COOLING configuration) with an empty hydraulic circuit and without a power supply, correct maintenance (not operating) is possible up to an outdoor air temperature of -20°C.

1. Max. inlet air temperature - Unit at full load
2. Max. inlet air temperature - Unit at part load
3. Min. inlet air temperature - Unit at full load and outdoor air at rest
4. Min. inlet air temperature - Unit at part load and outdoor air at rest

5. Minimum input air temperature - Stepped unit and air speed at 0.5 m/s.
6. Minimum input air temperature - Stepped unit and air speed at 1 m/s
7. Standard unit without Low liquid temperature device and air entering the external exchanger at 35°C
8. Unit with Low liquid temperature device and air entering the external exchanger at 35°C. Fluid treated with 40% ethylene glycol.

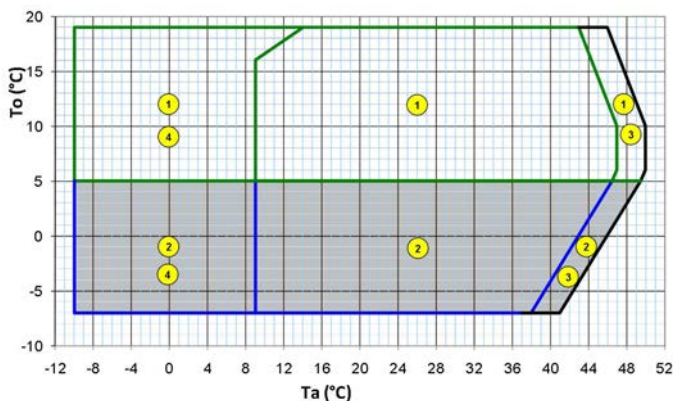

Graph referred to size 352
The detail of each size is shown in tabular data.

Ta (°C) = external exchanger inlet air temperature (dry bulb).
To (°C) = internal exchanger outlet water temperature

1. Standard unit: (no "Liquid low temperature" configuration)
2. Unit in "Low liquid temperature" configuration (40% ethylene glycol).
3. capacity-controlled unit (automatic capacity control)
4. Unit at full load: (automatic modulation of the air flow rate)

Performances in cooling (SC)

Acoustic configuration: compressor soundproofing (SC)

Size	To (°C)	External exchanger input air temperature (°C)											
		25		30		35		40		44		46	
		kWf	kWe	kWf	kWe	kWf	kWe	kWf	kWe	kWf	kWe	kWf	kWe
352	5	100,7	22,4	95,6	24,6	90,3	26,9	84,7	29,5	80,1	31,7	77,7	32,8
	6	103,8	22,6	98,6	24,8	93,2	27,2	87,4	29,7	82,7	31,9	80,3	33
	7	107	22,8	101,6	25	96	27,4	90,2	30	85,3	32,1	82,9	33,3
	8	110,2	23	104,7	25,2	98,9	27,6	93	30,2	88	32,4	85,5	33,5
	9	113,4	23,2	107,7	25,4	101,9	27,9	95,8	30,4	90,7	32,6	88,2	33,7
	10	116,6	23,4	110,8	25,7	104,8	28,1	98,6	30,7	93,5	32,8	90,9	33,9
402	5	114,3	25,9	108,6	28,4	102,6	31,1	96,3	34	91	36,5	88,2	37,7
	6	118	26,1	112,2	28,7	106	31,4	99,5	34,2	94	36,7	91,2	37,9
	7	121,7	26,4	115,7	28,9	109,3	31,6	102,6	34,5	97	36,9	94,1	38,1
	8	125,3	26,6	119,1	29,2	112,5	31,9	105,6	34,7	99,8	37,1	96,8	38,3
	9	128,8	26,9	122,4	29,4	115,6	32,1	108,5	35	102,5	37,3	99,4	38,5
	10	132,3	27,1	125,7	29,7	118,7	32,4	111,3	35,2	105,1	37,6	101,9	38,8
432	5	126,5	29	120	31,7	113,4	34,8	106,4	38,1	100,7	41	97,8	42,5
	6	130,5	29,3	123,9	32	117	35,1	109,9	38,4	104	41,3	101	42,8
	7	134,6	29,5	127,8	32,3	120,7	35,4	113,4	38,7	107,3	41,6	104,3	43
	8	138,7	29,8	131,6	32,6	124,3	35,7	116,8	39	110,7	41,8	107,6	43,3
	9	142,7	30,1	135,4	32,9	128	36	120,3	39,3	114	42,1	110,9	43,5
	10	146,7	30,4	139,2	33,2	131,6	36,3	123,8	39,6	117,4	42,3	114,2	43,8
452	5	134,7	29,4	128,3	32,4	121,5	35,7	114,3	39,2	108,3	42,3	105,2	43,9
	6	139,1	29,7	132,5	32,7	125,5	35,9	118	39,5	111,8	42,5	108,7	44,1
	7	143,5	30	136,7	32,9	129,4	36,2	121,8	39,7	115,4	42,8	112,1	44,3
	8	147,9	30,2	140,8	33,2	133,4	36,5	125,5	40	118,9	43	115,6	44,6
	9	152,3	30,5	145	33,5	137,3	36,8	129,2	40,3	122,5	43,2	119	44,8
	10	156,7	30,7	149,1	33,8	141,2	37	132,9	40,5	126	43,5	122,5	45
502	5	146,9	32,8	139,8	36,1	132,4	39,7	124,6	43,7	118,2	47,3	114,9	49,1
	6	151,7	33,1	144,3	36,4	136,7	40	128,6	44	122	47,6	118,6	49,4
	7	156,5	33,4	148,9	36,7	140,9	40,3	132,7	44,4	125,9	47,8	122,4	49,7
	8	161,3	33,8	153,4	37	145,2	40,7	136,8	44,7	129,8	48,1	126,2	50
	9	166	34,1	157,9	37,3	149,5	41	140,8	45	133,7	48,4	130	50,2
	10	170,8	34,4	162,4	37,7	153,8	41,3	144,9	45,3	137,6	48,7	–	–
552	5	158,5	35,9	151	39,5	143,2	43,5	134,9	47,8	128	51,6	124,5	53,6
	6	163,7	36,3	156	39,8	147,8	43,8	139,2	48,2	132,1	51,9	128,4	53,9
	7	168,9	36,6	160,9	40,2	152,4	44,1	143,5	48,5	136,1	52,2	132,3	54,2
	8	174	37	165,8	40,5	157	44,5	147,9	48,8	140,2	52,5	136,3	54,4
	9	179,2	37,3	170,6	40,9	161,7	44,8	152,2	49,1	144,4	52,7	140,4	54,7
	10	184,4	37,7	175,5	41,2	166,2	45,1	156,6	49,4	148,6	53	144,5	54,9
602	5	183	41,3	174,2	45,5	164,9	50,1	155,2	55,2	147,1	59,7	143	62
	6	188,5	41,7	179,4	45,9	169,8	50,5	159,8	55,6	151,5	60	147,3	62,3
	7	194,2	42,1	184,7	46,3	174,9	50,9	164,6	56	156,1	60,3	151,8	62,6
	8	200	42,5	190,2	46,7	180,1	51,3	169,6	56,3	160,9	60,6	156,4	62,9
	9	205,9	42,9	195,9	47,1	185,5	51,7	174,7	56,7	165,7	60,9	161,2	63,2
	10	212,1	43,4	201,7	47,6	191	52,1	179,9	57	170,8	61,2	166,1	63,4
702	5	203,1	46,1	193,9	50,3	184,2	55,3	174,1	60,9	165,7	65,9	161,4	68,6
	6	209,4	46,4	199,8	50,7	189,9	55,7	179,5	61,3	170,8	66,3	166,4	69
	7	215,8	46,8	206	51,1	195,7	56	184,9	61,7	176	66,7	171,5	69,4
	8	222,4	47,2	212,2	51,5	201,6	56,4	190,5	62,1	181,3	67,1	176,6	69,8
	9	229,1	47,5	218,7	51,9	207,7	56,8	196,3	62,5	186,7	67,5	181,9	70,2
	10	236	47,9	225,2	52,3	213,9	57,3	202,1	62,9	192,2	67,9	187,2	70,6
802	5	225	52,4	215	57	204,6	62,4	193,8	68,6	184,9	74,3	180,3	77,4
	6	231,9	52,8	221,6	57,4	210,9	62,8	199,7	69,1	190,5	74,8	185,8	77,9
	7	239	53,2	228,3	57,8	217,3	63,2	205,8	69,6	196,3	75,3	191,4	78,3
	8	246,2	53,6	235,2	58,2	223,8	63,7	211,9	70,1	202,2	75,8	197,2	78,8
	9	253,5	53,9	242,2	58,6	230,5	64,2	218,2	70,5	208,1	76,3	203	79,3
	10	261,1	54,4	249,4	59,1	237,3	64,6	224,7	71	214,2	76,8	–	–

kWf = Cooling capacity in kW

The data do not consider the pump share, required to overcome the pressure drop for the solution circulation inside the exchangers

kWe = Electrical power absorbed by compressors (kW)

To = Leaving water temperature on hydraulic circuit, cooling side (°C), load input/output = 5°C

Sound levels (SC)

Acoustic configuration: compressor soundproofing (SC)

Size	Sound power level (dB)								Sound power level	Sound pressure level
	Octave band (Hz)									
	63	125	250	500	1000	2000	4000	8000	dB(A)	dB(A)
352	90	88	87	84	78	74	66	59	85	67
402	90	87	86	84	79	75	67	59	85	67
432	90	88	87	85	80	77	68	59	86	68
452	91	89	87	85	81	75	68	60	86	68
502	91	89	88	86	81	76	68	60	87	68
552	92	89	89	86	82	77	69	61	88	69
602	91	89	88	86	83	77	69	60	88	69
702	93	91	90	88	84	78	70	62	89	70
802	93	91	90	88	84	78	70	62	89	70

Sound levels refer to full load units, in test nominal conditions. The sound pressure level refers to 1 m. from the unit outer surface operating in open field. Measures according to UNI EN ISO 9614-2 regulations, with respect to the EUROVENT 8/1 certification.

Data referred to the following conditions:
 internal exchanger water = 12/7°C
 outdoor air temperature 35°C

Internal exchanger pressure drops

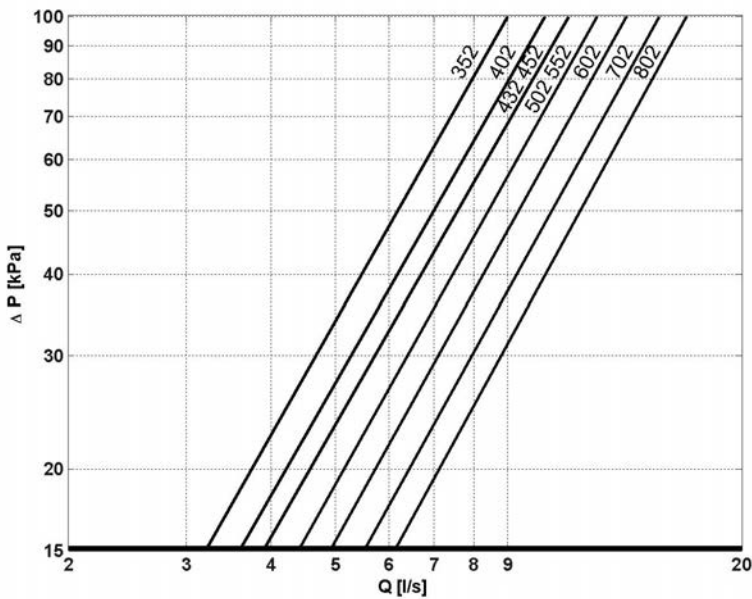

The pressure drops on the water side are calculated by considering an average water temperature at 7°C

Q = Water flow rate (l/s)
 DP = Pressure drop [kPa]

The water flow rate must be calculated with the following formula

$$Q \text{ [l/s]} = \frac{kWf}{(4,186 \times DT)}$$

kWf = Cooling capacity in kW
 DT = Temperature difference between inlet / outlet water



To the internal exchanger pressure drops must be added the pressure drops of the mechanical steel mesh strainer that must be placed on the water input line. It is a device compulsory for the correct unit operation, and it is available as Clivet option. (See the HYDRONIC ASSEMBLY ACCESSORIES). If the mechanical strainer is selected and installed by the Customer, it is forbidden the use of filters with the mesh pitch higher than 1,6 mm, because they can cause a bad unit operation and also its serious damaging.

Admissible water flow rates

Min. (Qmin) and max. (Qmax) water flow-rates admissible for the correct unit operation.

Size		352	402	432	452	502	552	602	702	802
Qmin	[l/s]	3,2	3,6	3,9	3,9	4,4	4,4	4,9	5,5	6,1
Qmax	[l/s]	9,0	10,2	11,1	11,1	12,2	12,2	13,5	15,1	16,6

Excellence version (EN)

General technical data (EN)

Acoustic Treatment: extremely low noise (EN)

Size			352	402	432	452	502	552	602	702	802
Cooling											
Cooling capacity	1	kW	91,5	104	116	125	134	145	165	185	207
Compressor power input	1	kW	28,5	32,9	37,1	37,7	42,1	46,1	53,4	58,5	66,2
Total power input	2	kW	30,1	34,5	38,7	39,9	44,3	48,3	55,6	61,4	69,1
Total recovery heating capacity	3	kW	119	139	151	161	176	190	215	242	269
Partial recovery heating capacity	3	kW	30,0	34,2	38,2	40,6	44,2	48,0	55,1	60,8	68,8
EER	1		3,04	3,01	2,99	3,13	3,03	3,01	2,96	3,01	3,00
Cooling capacity (EN14511:2013)	4	kW	91,0	103	115	124	134	145	164	184	206
Total power input (EN14511:2013)	4	kW	30,6	35,2	39,3	40,6	44,9	48,9	56,4	62,0	69,9
EER (EN 14511:2013)	4		2,97	2,94	2,93	3,06	2,98	2,96	2,91	2,97	2,95
SEER	8		4,31	4,45	4,23	4,60	4,41	4,35	4,23	4,40	4,21
Compressor											
Type of compressors			SCROLL	SCROLL	SCROLL	SCROLL	SCROLL	SCROLL	SCROLL	SCROLL	SCROLL
No. of compressors		No	2	2	2	2	2	2	2	2	2
Rated power (C1)		HP	35	40	43	45	50	55	60	70	80
Std Capacity control steps		No	3	3	3	3	3	3	2	3	2
Oil charge (C1)		l	8,00	10,0	12,0	10,0	11,0	13,0	13,0	13,0	13,0
Refrigerant charge (C1)	5	kg	28,3	28,3	31,9	39,5	39,5	39,5	44,6	51,3	57,9
Refrigeration circuits		No	1	1	1	1	1	1	1	1	1
Internal exchanger											
Type of internal exchanger	6		PHE	PHE	PHE	PHE	PHE	PHE	PHE	PHE	PHE
Water flow rate (Utility Side)	1	l/s	4,40	5,00	5,50	6,00	6,40	6,90	7,90	8,80	9,90
Internal exchanger pressure drops	1	kPa	26,8	26,9	28,0	32,1	30,8	35,1	37,3	36,3	38,1
Water content		l	6.90	8.00	8.90	8.90	10.1	10.1	11.9	14.2	17.2
Min. installation water contents	9	l	403	385	522	350	482	667	908	870	1159
External Section Fans											
Type of fans	7		AX	AX	AX	AX	AX	AX	AX	AX	AX
Number of fans		No	2	2	2	3	3	3	3	4	4
Standard air flow		l/s	9636	9571	9517	14358	14358	14253	14138	18925	18798
Connections											
Water connections			2"1/2	2"1/2	2"1/2	2"1/2	2"1/2	2"1/2	2"1/2	2"1/2	2"1/2
Power supply											
Standard power supply		V	400/3/50	400/3/50	400/3/50	400/3/50	400/3/50	400/3/50	400/3/50	400/3/50	400/3/50
Dimensions											
A - Length		mm	3075	3075	3075	4025	4025	4025	4025	5025	5025
B - Width		mm	1097	1097	1097	1097	1097	1097	1097	1097	1097
C - Height		mm	1805	1805	1805	1805	1805	1805	1805	1805	1805
Standard unit weights											
Shipping weight		kg	889	925	1015	1198	1224	1246	1290	1483	1527
Operating weight		kg	896	933	1024	1207	1234	1256	1302	1497	1544

The Product is compliant with the Erp (Energy Related Products) European Directive. It includes the Commission delegated Regulation (EU) No 2016/2281, also known as Ecodesign LOT21.

Contains fluorinated greenhouse gases(GWP 2087,5)

1. Data referred to the following conditions: internal exchanger water = 12/7 °C external exchanger inlet air 35°C
2. The Total Power Input value does not take into account the part related to the pumps and required to overcome the pressure drops for the circulation of the solution inside the exchangers
3. Option. Recovery exchanger water = 40/45°C
4. Data calculated in compliance with Standard EN 14511:2013 referred to the following conditions: Internal exchanger water temperature = 12/7°C. External exchanger intake air temperature = 35°C

5. indicative values for standard units with possible +/-10% variation. The actual data are indicated on the label of the unit.
6. PHE = plates
7. AX = axial fan
8. Data calculated according to the EN 14825:2016 Regulation
9. The calculated water volume to the system does not consider the volume of water contained in the internal exchanger. With applications at low outdoor air temperature or low average loads requested, the minimum water volume to the system is obtained by increasing the indicated value by 40%.

Electrical data (EN)

Acoustic Treatment: extremely low noise (EN)

Size		352	402	432	452	502	552	602	702	802
F.L.A. - Full load current at max admissible conditions										
F.L.A. - Total	A	76,1	84,5	94,2	102,9	108,6	117	131,4	150	164,5
F.L.I. - Full load power input at max admissible conditions										
F.L.I. - Total	kW	44,2	49,0	56,6	60,0	65,4	70,2	79,0	91,8	102,4
M.I.C. Maximum inrush current										
M.I.C. - Value	A	264,6	311,6	321,3	353,7	359,3	367,7	382,1	470,2	484,7

Voltage unbalance: max 2 %

Power supply: 400/3/50 Hz +/- 10%

Electrical data refer to standard units; according to the installed accessories, the data can suffer some variations.

Operating range - Cooling (EN)

Acoustic Treatment: extremely low noise (EN)

Size			352	402	432	452	502	552	602	702	802
External exchanger											
Max inlet air temperature	1	°C	46	45	44	46	46	45	44	46	45
Max inlet air temperature	2	°C	47	46	46	47	47	46	46	47	46
Max inlet air temperature	3	°C	50	50	50	50	50	50	50	50	50
Min. inlet air temperature	4	°C	-10	-10	-10	-10	-10	-10	-10	-10	-10
Min. inlet air temperature	5	°C	-7,0	-7,0	-7,0	-7,0	-7,0	-7,0	-7,0	-7,0	-7,0
Min. inlet air temperature	6	°C	-2,0	-2,0	-2,0	-2,0	-2,0	-2,0	-2,0	-2,0	-2,0
Min. inlet air temperature	7	°C	11	11	11	11	11	11	11	11	11
Internal exchanger											
Max inlet water temperature		°C	24	24	24	24	24	24	24	24	24
Min. outlet water temperature	8	°C	5,0	5,0	5,0	5,0	5,0	5,0	5,0	5,0	5,0
Min. outlet water temperature	9	°C	-7,0	-7,0	-7,0	-7,0	-7,0	-7,0	-7,0	-7,0	-7,0

Data referred to the following conditions:

internal exchanger water = 12/7°C

air at rest

Caution: Air conditions which are at rest are defined as the absence of air flowing towards the unit. Weak winds can induce air to flow through the exchanger and air-levels which can cause a reduction in the operating range. In the presence of predominant winds it is necessary to use suitable windbreak barriers.

N.B. To ensure the correct maintenance (no operation) with outdoor air temperatures less than -10°C, the Standard unit (no FREE-COOLING configuration) must be equipped with the "Electrical panel anti-freeze protection" option and continue to be supplied with power. The hydraulic circuit must be filled with an adequate percentage of anti-freeze. In these conditions, the minimum outdoor air temperature which is permitted depends on the model of the "Electrical panel anti-freeze protection" option which has been chosen, up to a limit value of -39°C.

The operating mode can also be extended up to an outdoor air temperature of -25°C, but only in the FREE-COOLING configuration which is complete with an "Electrical panel anti-freeze protection" option of an adequate size.

The operating mode can be further extended to external air temperatures of 39°C. Only in the full FREE-COOLING configuration of the 'Device to reduce consumption of external section fans operating at variable speed (phase cut)' and 'Electrical panel antifreeze protection' of an adequate size.

In the Standard unit (no FREE-COOLING configuration) with an empty hydraulic circuit and without a power supply, correct maintenance (not operating) is possible up to an outdoor air temperature of -20°C.

1. Max. inlet air temperature - Unit at full load
2. Input air maximum temperature - Unit operating at full load with fans automatically forced at maximum speed (the sound levels in this particular operating condition are the same as the standard acoustic configuration SC)
3. Max. inlet air temperature - Unit at part load
4. Min. inlet air temperature - Unit at full load and outdoor air at rest

5. Min. inlet air temperature - Unit at part load and outdoor air at rest
6. Minimum input air temperature - Stepped unit and air speed at 0.5 m/s.
7. Minimum input air temperature - Stepped unit and air speed at 1 m/s
8. Standard unit without Low liquid temperature device and air entering the external exchanger at 35°C
9. Unit with Low liquid temperature device and air entering the external exchanger at 35°C. Fluid treated with 40% ethylene glycol.

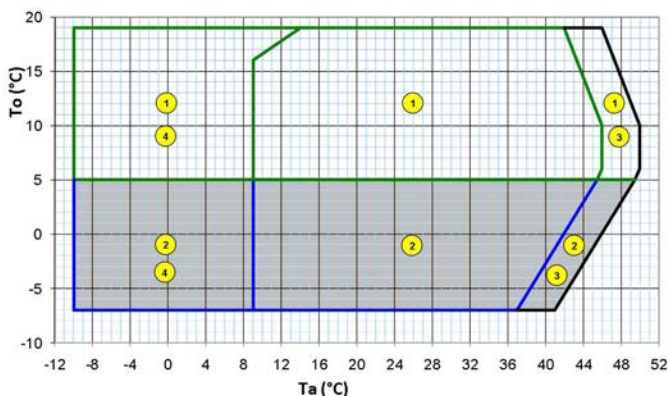

Graph referred to size 352
The detail of each size is shown in tabular data.

Ta (°C) = external exchanger inlet air temperature (dry bulb).
To (°C) = internal exchanger outlet water temperature

1. Standard unit: (no "Liquid low temperature" configuration)
2. Unit in "Low liquid temperature" configuration (40% ethylene glycol).
3. capacity-controlled unit (automatic capacity control)
4. Unit at full load: (automatic modulation of the air flow rate)

Performances in cooling (EN)

Acoustic Treatment: extremely low noise (EN)

Size	To (°C)	External exchanger input air temperature (°C)											
		25		30		35		40		42		44	
		kWf	kWe	kWf	kWe	kWf	kWe	kWf	kWe	kWf	kWe	kWf	kWe
352	5	96,4	23,4	91,4	25,6	86,1	28	80,7	30,6	78,4	31,7	76,1	32,8
	6	99,4	23,6	94,2	25,8	88,8	28,3	83,2	30,9	80,9	31,9	78,6	33
	7	102,4	23,8	97	26,1	91,5	28,5	85,8	31,1	83,4	32,2	81,1	33,3
	8	105,4	24	99,9	26,3	94,2	28,8	88,4	31,4	86	32,4	83,6	33,5
	9	108,4	24,3	102,8	26,6	97	29	91,1	31,6	88,6	32,7	86,2	33,8
	10	111,5	24,5	105,7	26,8	99,8	29,3	93,7	31,9	91,3	33	88,8	34
402	5	109,4	27	103,7	29,6	97,8	32,4	91,5	35,3	89	36,5	86,3	37,7
	6	113	27,3	107,1	29,9	100,9	32,6	94,5	35,5	91,9	36,7	89,3	37,9
	7	116,4	27,6	110,3	30,2	104	32,9	97,4	35,8	94,7	36,9	91,9	38,1
	8	119,6	27,9	113,5	30,4	107	33,2	100,1	36,1	97,2	37,3	94,2	38,5
	9	122,7	28,3	116,7	30,7	110	33,4	102,6	36,4	99,5	37,7	96,2	39
	10	125,6	28,7	119,7	31	112,8	33,7	105	36,8	101,6	38,1	98	39,6
432	5	121,9	30,3	115,5	33,3	108,8	36,4	101,8	39,9	99	41,3	96,2	42,8
	6	125,6	30,8	119,2	33,6	112,3	36,7	104,8	40,3	101,7	41,8	98,5	43,4
	7	129,3	31,2	122,8	33,9	115,7	37,1	108	40,7	104,7	42,2	101,4	43,9
	8	133	31,6	126,2	34,3	119	37,5	111,3	41	108,1	42,5	104,8	44,1
	9	136,7	31,9	129,6	34,8	122,2	37,9	114,8	41,2	111,8	42,6	108,7	44
	10	140,5	32,2	132,7	35,3	125,4	38,4	118,4	41,4	115,7	42,6	113,1	43,8
452	5	130,6	30,7	124,1	33,7	117,3	37,1	110,2	40,7	107,2	42,2	104,2	43,8
	6	134,8	31	128,1	34	121,1	37,4	113,7	41	110,7	42,5	107,6	44
	7	139	31,2	132,1	34,3	124,9	37,7	117,3	41,2	114,1	42,7	111	44,3
	8	143,2	31,5	136,1	34,6	128,6	38	120,8	41,5	117,6	43	114,3	44,5
	9	147,4	31,8	140	34,9	132,3	38,3	124,3	41,8	121,1	43,2	117,7	44,7
	10	151,5	32,1	143,9	35,3	136,1	38,6	127,9	42,1	124,5	43,5	121,1	45
502	5	140,7	34,2	133,7	37,6	126,4	41,4	118,8	45,5	115,6	47,3	112,5	49,1
	6	145,3	34,6	138	38	130,4	41,7	122,5	45,9	119,3	47,6	116,1	49,4
	7	149,8	34,9	142,2	38,3	134,4	42,1	126,3	46,2	123	47,9	119,7	49,7
	8	154,3	35,3	146,5	38,7	138,4	42,4	130,1	46,5	126,7	48,3	123,3	50,1
	9	158,8	35,6	150,8	39	142,5	42,8	133,9	46,9	130,5	48,6	126,9	50,4
	10	163,2	36	155	39,4	146,5	43,2	137,8	47,2	134,2	49	130,6	50,7
552	5	151,8	37,5	144,4	41,3	136,6	45,4	128,4	49,8	125,1	51,7	121,6	53,7
	6	156,7	37,9	149	41,6	140,9	45,7	132,4	50,2	128,9	52,1	125,4	54
	7	161,6	38,3	153,6	42	145,2	46,1	136,4	50,5	132,8	52,4	129,1	54,3
	8	166,4	38,7	158,2	42,4	149,5	46,5	140,5	50,9	136,7	52,7	132,9	54,6
	9	171,3	39,1	162,8	42,8	153,9	46,8	144,6	51,2	140,7	53	136,8	54,9
	10	176,1	39,5	167,4	43,2	158,2	47,2	148,6	51,5	144,7	53,3	140,7	55,1
602	5	173,3	43,4	164,5	47,8	155,4	52,6	145,9	57,8	142	60	138,1	62,3
	6	178,4	43,8	169,4	48,2	160	53	150,3	58,2	146,3	60,4	142,2	62,6
	7	183,6	44,3	174,3	48,6	164,7	53,4	154,7	58,5	150,6	60,7	146,4	63
	8	189	44,7	179,5	49,1	169,5	53,8	159,3	58,9	155,1	61,1	150,8	63,3
	9	194,6	45,2	184,7	49,5	174,5	54,2	164	59,3	159,6	61,4	155,3	63,6
	10	200,3	45,7	190,1	50	179,6	54,7	168,8	59,7	164,3	61,8	159,9	64
702	5	192,8	47,9	183,7	52,4	174,3	57,6	164,4	63,5	160,4	66	156,3	68,6
	6	198,7	48,3	189,3	52,9	179,5	58,1	169,4	63,9	165,2	66,4	161	69,1
	7	204,7	48,7	195	53,3	184,9	58,5	174,5	64,4	170,2	66,9	165,9	69,5
	8	210,8	49,2	200,8	53,8	190,4	59	179,7	64,8	175,2	67,3	170,7	69,9
	9	217,1	49,6	206,8	54,2	196,1	59,4	184,9	65,3	180,3	67,8	175,7	70,4
	10	223,4	50,1	212,9	54,7	201,8	59,9	190,3	65,8	185,5	68,3	180,7	70,9
802	5	215,4	54,6	205,5	59,5	195,3	65,2	184,6	71,8	180,3	74,7	175,8	77,7
	6	221,9	55	211,7	59,9	201,1	65,7	190,2	72,3	185,7	75,2	181,1	78,2
	7	228,5	55,4	218	60,4	207,1	66,2	195,9	72,9	191,2	75,7	186,5	78,7
	8	235,3	55,9	224,5	60,9	213,3	66,7	201,7	73,4	196,9	76,3	192,1	79,3
	9	242,3	56,3	231,1	61,4	219,5	67,3	207,6	73,9	202,7	76,8	197,8	79,8
	10	249,4	56,8	237,9	62	226	67,8	213,7	74,5	208,7	77,3	203,6	80,3

kWf = Cooling capacity in kW

The data do not consider the pump share, required to overcome the pressure drop for the solution circulation inside the exchangers

kWe = Electrical power absorbed by compressors (kW)

To = Leaving water temperature on hydraulic circuit, cooling side (°C), load input/output = 5°C

Sound levels (EN)

Acoustic Treatment: extremely low noise (EN)

Size	Sound power level (dB)								Sound power level	Sound pressure level
	Octave band (Hz)									
	63	125	250	500	1000	2000	4000	8000	dB(A)	dB(A)
352	82	84	84	80	71	68	60	55	81	63
402	82	83	84	80	74	70	62	57	81	63
432	82	83	86	82	75	71	62	57	83	65
452	85	85	86	83	76	70	63	58	83	65
502	84	85	87	83	76	71	63	57	84	66
552	84	85	87	83	78	72	64	59	84	66
602	84	85	87	84	78	72	64	58	85	66
702	86	86	88	85	79	73	65	59	86	67
802	86	86	89	85	80	73	66	60	86	67

Sound levels refer to full load units, in test nominal conditions. The sound pressure level refers to 1 m. from the unit outer surface operating in open field. Measures according to UNI EN ISO 9614-2 regulations, with respect to the EUROVENT 8/1 certification.

Data referred to the following conditions:
 internal exchanger water = 12/7°C
 outdoor air temperature 35°C

The indicated sound levels are only valid within the operating field of the unit in the "Supersilenced EN" configuration; with fresh air temperatures which are higher and in any case within the operating field of the "Soundproofed Compressors SC" configuration bearing in mind the sound levels of the unit in the "Soundproofed Compressors SC" configuration.

Internal exchanger pressure drops

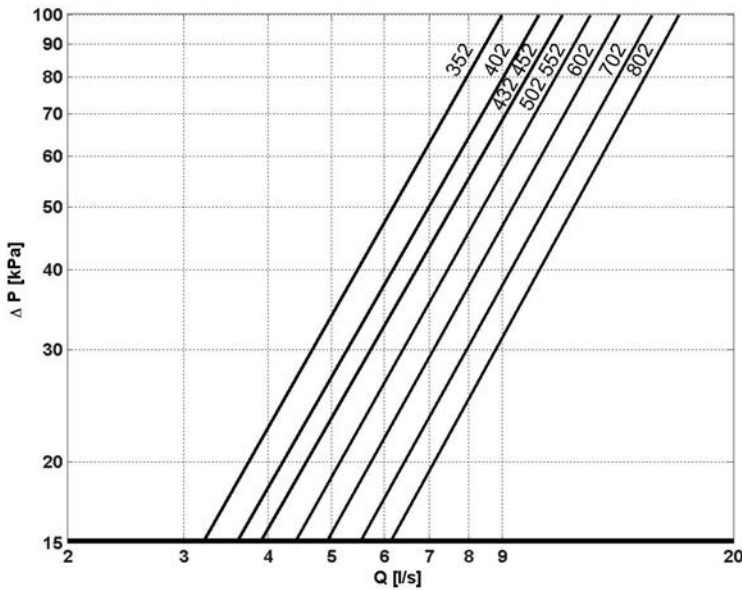

The pressure drops on the water side are calculated by considering an average water temperature at 7°C

Q = water flow rate (l/s)
 DP = pressure drop [kPa]

The water flow rate must be calculated with the following formula

$$Q \text{ [l/s]} = \frac{kWf}{4,186 \times DT}$$

kWf = Cooling capacity in kW
 DT = Temperature difference between inlet / outlet water



To the internal exchanger pressure drops must be added the pressure drops of the mechanical steel mesh strainer that must be placed on the water input line. It is a device compulsory for the correct unit operation, and it is available as Clivet option. (See the HYDRONIC ASSEMBLY ACCESSORIES). If the mechanical strainer is selected and installed by the Customer, it is forbidden the use of filters with the mesh pitch higher than 1,6 mm, because they can cause a bad unit operation and also its serious damaging.

Admissible water flow rates

Min. (Qmin) and max. (Qmax) water flow-rates admissibles for the correct unit operation.

Size		352	402	432	452	502	552	602	702	802
Qmin	[l/s]	3,2	3,6	3,9	3,9	4,4	4,4	4,9	5,5	6,1
Qmax	[l/s]	9,0	10,2	11,1	11,1	12,2	12,2	13,5	15,1	16,6

Premium version (SC)

General technical data (SC)

Acoustic configuration: compressor soundproofing (SC)

Size			352	402	432	452	502	552	602	702	802
Cooling											
Cooling capacity	1	kW	90,3	101	111	120	131	144	160	185	204
Compressor power input	1	kW	28,8	33,8	38,0	40,3	43,9	49,1	56,8	61,1	70,3
Total power input	2	kW	32,1	37,1	41,3	43,7	47,4	52,6	60,1	66,0	75,1
Total recovery heating capacity	3	kW	114	129	144	155	169	186	208	238	263
Partial recovery heating capacity	3	kW	30,0	33,9	37,7	40,5	43,6	47,9	54,5	60,9	68,4
EER	1		2,81	2,73	2,69	2,75	2,75	2,73	2,66	2,81	2,71
Cooling capacity (EN14511:2013)	4	kW	89,8	101	111	119	130	143	159	185	203
Total power input (EN14511:2013)	4	kW	32,6	37,7	42,0	44,2	48,0	53,2	61,0	66,9	75,9
EER (EN 14511:2013)	4		2,75	2,67	2,64	2,70	2,71	2,69	2,61	2,76	2,67
SEER	8		3,81	3,80	3,80	3,85	3,85	3,81	3,82	3,89	3,81
Compressor											
Type of compressors			SCROLL	SCROLL	SCROLL	SCROLL	SCROLL	SCROLL	SCROLL	SCROLL	SCROLL
No. of compressors		No	2	2	2	2	2	2	2	2	2
Rated power (C1)		HP	35	40	43	45	50	55	60	70	80
Std Capacity control steps		No	3	3	3	3	3	3	2	3	2
Oil charge (C1)		l	8,00	10,0	12,0	10,0	11,0	13,0	13,0	13,0	13,0
Refrigerant charge (C1)	5	kg	18	18	22	24	27	27	32	39	39
Refrigeration circuits		No	1	1	1	1	1	1	1	1	1
Internal exchanger											
Type of internal exchanger	6		PHE	PHE	PHE	PHE	PHE	PHE	PHE	PHE	PHE
Water flow rate (Utility Side)	1	l/s	4,30	4,80	5,30	5,70	6,20	6,90	7,60	8,90	9,70
Internal exchanger pressure drops	1	kPa	47,2	47,1	47,6	45,2	41,1	41,1	43,1	44,7	44,1
Water content		l	4,80	5,50	6,10	6,90	8,00	8,90	10,1	11,9	14,2
Min. installation water contents	9	l	397	374	500	336	472	662	880	870	1142
External Section Fans											
Type of fans	7		AX	AX	AX	AX	AX	AX	AX	AX	AX
Number of fans		No	2	2	2	2	2	2	2	3	3
Standard air flow		l/s	12474	12474	12394	12119	11871	11871	12268	18536	18536
Connections											
Water connections			2" 1/2	2" 1/2	2" 1/2	2" 1/2	2" 1/2	2" 1/2	2" 1/2	2" 1/2	2" 1/2
Power supply											
Standard power supply		V	400/3/50	400/3/50	400/3/50	400/3/50	400/3/50	400/3/50	400/3/50	400/3/50	400/3/50
Dimensions											
A - Length		mm	2710	2710	2710	2710	2710	2710	3075	4025	4025
B - Width		mm	1097	1097	1097	1097	1097	1097	1097	1097	1097
C - Height		mm	1805	1805	1805	1805	1805	1805	1805	1805	1805
Standard unit weights											
Shipping weight		kg	773	796	885	917	955	975	1077	1283	1310
Operating weight		kg	778	802	892	924	963	984	1087	1295	1324

The Product is compliant with the Erp (Energy Related Products) European Directive. It includes the Commission delegated Regulation (EU) No 2016/2281, also known as Ecodesign LOT21.

Contains fluorinated greenhouse gases(GWP 2087,5)

1. Data referred to the following conditions: internal exchanger water = 12/7 °C external exchanger inlet air 35°C
2. data referred to the following conditions: internal exchanger water = 12/7 °C. external exchanger inlet water 35°C
3. The Total Power Input value does not take into account the part related to the pumps and required to overcome the pressure drops for the circulation of the solution inside the exchangers
4. Option. Recovery exchanger water = 40/45°C
5. Data calculated in compliance with Standard EN 14511:2013 referred to the following conditions: Internal exchanger water temperature = 12/7°C. External exchanger intake air temperature = 35°C indicative values for standard units with possible +/-10% variation. The actual data are indicated on the label of the unit.

6. PHE = plates
7. AX = axial fan
8. Data calculated according to the EN 14825:2016 Regulation
9. The calculated water volume to the system does not consider the volume of water contained in the internal exchanger. With applications at low outdoor air temperature or low average loads requested, the minimum water volume to the system is obtained by increasing the indicated value by 40%.

Electrical data (SC)

Acoustic configuration: compressor soundproofing (SC)

Size		352	402	432	452	502	552	602	702	802
F.L.A. - Full load current at max admissible conditions										
F.L.A. - Total	A	76,1	84,5	90,1	98,8	104,5	112,9	127,3	145,9	160,4
F.L.I. - Full load power input at max admissible conditions										
F.L.I. - Total	kW	44,2	49,0	54,4	57,8	63,2	68,0	76,8	89,6	100,2
M.I.C. Maximum inrush current										
M.I.C. - Value	A	264,6	311,6	317,2	349,6	355,2	363,6	378	466,1	480,6

Voltage unbalance: max 2 %

Power supply: 400/3/50 Hz +/- 10%

Electrical data refer to standard units; according to the installed accessories, the data can suffer some variations.

Operating range - Cooling (SC)

Acoustic configuration: compressor soundproofing (SC)

Size			352	402	432	452	502	552	602	702	802
External exchanger											
Max inlet air temperature	1	°C	45	44	43	44	44	43	42	44	43
Max inlet air temperature	2	°C	50	50	50	50	50	50	50	50	50
Min. inlet air temperature	3	°C	-10	-10	-10	-10	-10	-10	-10	-10	-10
Min. inlet air temperature	4	°C	-7,0	-7,0	-7,0	-7,0	-7,0	-7,0	-7,0	-7,0	-7,0
Min. inlet air temperature	5	°C	-2,0	-2,0	-2,0	-2,0	-2,0	-2,0	-2,0	-2,0	-2,0
Min. inlet air temperature	6	°C	11	11	11	11	11	11	11	11	11
Internal exchanger											
Max inlet water temperature		°C	24	24	24	24	24	24	24	24	24
Min. outlet water temperature	7	°C	5,0	5,0	5,0	5,0	5,0	5,0	5,0	5,0	5,0
Min. outlet water temperature	8	°C	-7,0	-7,0	-7,0	-7,0	-7,0	-7,0	-7,0	-7,0	-7,0

Data referred to the following conditions:

internal exchanger water = 12/7°C

air at rest

Caution: Air conditions which are at rest are defined as the absence of air flowing towards the unit. Weak winds can induce air to flow through the exchanger and air-levels which can cause a reduction in the operating range. In the presence of predominant winds it is necessary to use suitable windbreak barriers.

N.B. To ensure the correct maintenance (no operation) with outdoor air temperatures less than -10°C, the Standard unit (no FREE-COOLING configuration) must be equipped with the "Electrical panel anti-freeze protection" option and continue to be supplied with power. The hydraulic circuit must be filled with an adequate percentage of anti-freeze. In these conditions, the minimum outdoor air temperature which is permitted depends on the model of the "Electrical panel anti-freeze protection" option which has been chosen, up to a limit value of -39°C.

The operating mode can also be extended up to an outdoor air temperature of -25°C, but only in the FREE-COOLING configuration which is complete with an "Electrical panel anti-freeze protection" option of an adequate size.

The operating mode can also be extended up to an external air temperature of -39°C, but only in the FREE-COOLING configuration which is complete with the "Electrical panel anti-freeze protection" option of an adequate size.

In the Standard unit (no FREE-COOLING configuration) with an empty hydraulic circuit and without a power supply, correct maintenance (not operating) is possible up to an outdoor air temperature of -20°C.

1. Max. inlet air temperature - Unit at full load
2. Max. inlet air temperature - Unit at part load
3. Min. inlet air temperature - Unit at full load and outdoor air at rest
4. Min. inlet air temperature - Unit at part load and outdoor air at rest

5. Minimum input air temperature - Stepped unit and air speed at 0.5 m/s.
6. Minimum input air temperature - Stepped unit and air speed at 1 m/s
7. Standard unit without Low liquid temperature device and air entering the external exchanger at 35°C
8. Unit with Low liquid temperature device and air entering the external exchanger at 35°C. Fluid treated with 40% ethylene glycol.

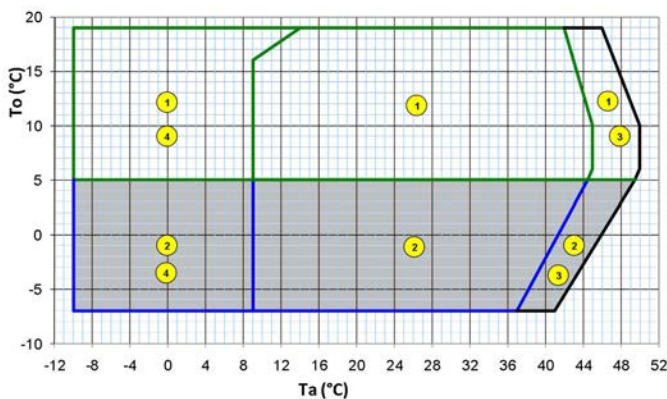

Graph referred to size 352
The detail of each size is shown in tabular data.

Ta (°C) = external exchanger inlet air temperature (dry bulb).
To (°C) = internal exchanger outlet water temperature

1. Standard unit; (no "Liquid low temperature" configuration)
2. Unit in "Low liquid temperature" configuration (40% ethylene glycol).
3. capacity-controlled unit (automatic capacity control)
4. Unit at full load: (automatic modulation of the air flow rate)

Performances in cooling (SC)

Acoustic configuration: compressor soundproofing (SC)

Size	To (°C)	Air temperature to the external exchanger (°C)											
		25		30		35		38		40		42	
		kWf	kWe	kWf	kWe	kWf	kWe	kWf	kWe	kWf	kWe	kWf	kWe
352	5	95	23,5	90,1	25,8	84,8	28,3	81,6	29,9	79,4	31	77,1	32,1
	6	98	23,8	92,9	26,1	87,6	28,5	84,2	30,1	81,9	31,2	79,6	32,3
	7	101	24	95,8	26,3	90,3	28,8	86,8	30,4	84,5	31,5	82,1	32,6
	8	104	24,2	98,6	26,6	93	29,1	89,5	30,6	87,1	31,7	84,7	32,8
	9	107	24,5	101,5	26,8	95,7	29,3	92,2	30,9	89,7	31,9	87,3	33
	10	110	24,7	104,3	27,1	98,4	29,6	94,8	31,1	92,4	32,2	89,9	33,3
402	5	107,5	27,7	101,8	30,4	95,8	33,2	92	35	89,4	36,3	86,8	37,5
	6	110,4	28	104,6	30,7	98,4	33,5	94,5	35,3	91,9	36,5	89,2	37,7
	7	113,5	28,3	107,5	31	101,2	33,8	97,2	35,5	94,5	36,7	91,8	38
	8	116,8	28,6	110,5	31,2	104	34	100	35,8	97,3	37	94,5	38,2
	9	120,2	28,8	113,8	31,5	107,1	34,3	103	36	100,2	37,2	97,3	38,4
	10	123,9	29,1	117,1	31,8	110,2	34,6	106	36,3	103,2	37,4	100,3	38,6
432	5	118	31	111,6	34,1	105	37,3	100,9	39,4	98,2	40,9	95,3	42,4
	6	121,6	31,3	115	34,4	108,1	37,7	103,9	39,8	101,1	41,2	98,2	42,7
	7	125,1	31,7	118,3	34,7	111,4	38	107,1	40	104,2	41,5	101,3	42,9
	8	128,6	32,1	121,6	35,1	114,7	38,3	110,5	40,3	107,7	41,6	104,9	43
	9	131,9	32,6	124,9	35,6	118,1	38,6	114,1	40,5	111,4	41,7	108,8	42,9
	10	135,1	33,1	128,2	36,1	121,6	39	117,9	40,6	115,5	41,7	113,1	42,7
452	5	126,5	32,9	120	36,1	113,1	39,6	108,8	41,8	105,9	43,3	102,9	44,9
	6	130,5	33,2	123,6	36,5	116,5	39,9	112,2	42,1	109,2	43,6	106,2	45,1
	7	134,4	33,6	127,3	36,8	120	40,3	115,5	42,4	112,5	43,9	109,3	45,4
	8	138,1	34	131,1	37,2	123,6	40,6	118,8	42,8	115,5	44,3	112,2	45,9
	9	141,8	34,5	134,9	37,5	127,1	40,9	122	43,2	118,5	44,8	114,8	46,4
	10	145,4	35	138,7	37,9	130,7	41,3	125,2	43,6	121,3	45,3	117,1	47,1
502	5	137,4	35,8	130,8	39,3	123,4	43,2	118,5	45,8	115,1	47,5	111,6	49,3
	6	141,3	36,1	134,5	39,7	126,9	43,6	121,9	46,1	118,4	47,8	114,8	49,6
	7	145,5	36,4	138,4	40	130,6	43,9	125,7	46,4	122,2	48,2	118,7	49,9
	8	150	36,8	142,4	40,4	134,6	44,3	129,8	46,8	126,5	48,6	123,2	50,3
	9	154,8	37,2	146,6	40,8	138,8	44,8	134,2	47,3	131,3	49	128,4	50,8
	10	159,9	37,5	151	41,2	143,2	45,2	139,1	47,7	136,5	49,5	134,2	51,3
552	5	151,7	40,1	143,6	44	135,2	48,3	130	51,1	126,5	53	123	54,9
	6	156,1	40,7	147,8	44,7	139,6	48,7	134,8	51,1	131,7	52,8	128,5	54,4
	7	160,6	41,3	152,1	45,2	143,8	49,1	139	51,5	135,8	53	132,7	54,6
	8	165,2	41,7	156,5	45,7	147,8	49,7	142,5	52,1	139	53,7	135,5	55,4
	9	169,8	42,2	161	46	151,5	50,3	145,4	53	141,3	54,9	136,9	56,8
	10	174,5	42,5	165,7	46,3	155	51	147,7	54,2	142,5	56,5	137	58,9
602	5	168,1	46,1	160	50,4	150,9	55,5	145	58,8	140,8	61,2	-	-
	6	173,3	46,7	164,7	51,2	155,3	56,1	149,4	59,3	145,4	61,6	-	-
	7	178,5	47,3	169,3	51,8	159,8	56,8	153,9	59,9	149,9	62	-	-
	8	183,6	48	174,1	52,4	164,3	57,3	158,4	60,4	154,4	62,5	-	-
	9	188,7	48,7	178,8	53	168,9	57,8	163	60,9	159	63,2	-	-
	10	193,7	49,6	183,7	53,4	173,6	58,2	167,5	61,5	163,5	63,9	-	-
702	5	194,9	50	185,3	54,7	175,3	60,1	169,1	63,7	164,9	66,1	160,6	68,7
	6	200,5	50,4	190,6	55,2	180,3	60,6	173,9	64,2	169,6	66,6	165,2	69,2
	7	206,2	50,9	196	55,7	185,5	61,1	178,9	64,6	174,5	67,1	170	69,7
	8	212,2	51,4	201,7	56,2	190,8	61,6	184,1	65,1	179,5	67,6	174,9	70,2
	9	218,4	51,8	207,5	56,7	196,3	62,1	189,4	65,6	184,8	68,1	180,1	70,6
	10	224,7	52,3	213,4	57,2	201,9	62,6	194,9	66,1	190,2	68,5	185,4	71
802	5	213	57,6	202,7	62,9	192	69,1	185,5	73,1	181,1	76	176,6	78,9
	6	219,1	58,2	208,9	63,4	197,8	69,6	190,7	73,8	185,7	76,8	180,6	80
	7	225,2	58,8	215	64	203,5	70,3	196,1	74,5	191	77,6	185,6	80,8
	8	231,6	59,6	220,8	64,8	209,2	71	201,8	75,3	196,7	78,3	191,5	81,5
	9	238,1	60,3	226,4	65,7	214,8	71,9	207,7	76	203,1	78,9	198,4	82
	10	244,7	61,1	231,9	66,7	220,3	72,9	213,9	76,8	209,9	79,5	206,1	82,3

kWf = Cooling capacity in kW

The data do not consider the pump share, required to overcome the pressure drop for the solution circulation inside the exchangers

kWe = Electrical power absorbed by compressors (kW)

To = Leaving water temperature on hydraulic circuit, cooling side (°C), load input/output = 5°C

Sound levels (SC)

Acoustic configuration: compressor soundproofing (SC)

Size	Sound power level (dB)								Sound power level	Sound pressure level
	Octave band (Hz)									
	63	125	250	500	1000	2000	4000	8000	dB(A)	dB(A)
352	90	88	86	84	78	74	66	58	85	67
402	89	87	86	83	79	75	67	59	85	67
432	89	87	86	84	79	75	67	58	85	67
452	89	87	86	84	80	74	67	58	85	67
502	89	86	86	84	80	75	67	57	85	68
552	89	87	86	85	81	76	68	59	86	68
602	89	87	86	85	81	76	68	58	86	68
702	91	89	88	87	83	77	69	60	88	69
802	91	89	88	86	83	77	69	60	88	69

Sound levels refer to full load units, in test nominal conditions. The sound pressure level refers to 1 m. from the unit outer surface operating in open field. Measures according to UNI EN ISO 9614-2 regulations, with respect to the EUROVENT 8/1 certification.

Data referred to the following conditions:
 internal exchanger water = 12/7°C
 outdoor air temperature 35°C

Internal exchanger pressure drops

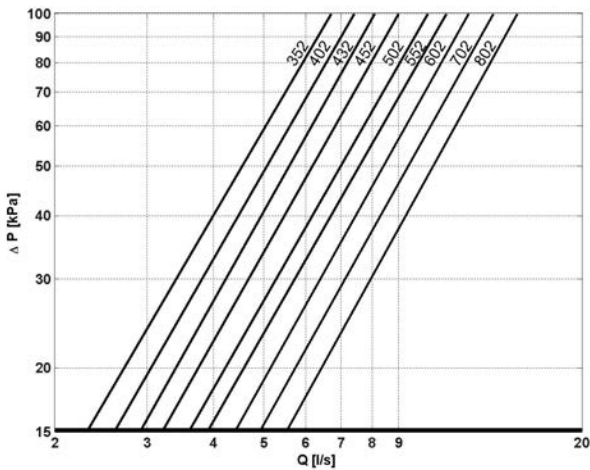

The pressure drops on the water side are calculated by considering an average water temperature at 7°

Q = water flow rate (l/s)
 DP = pressure drop [kPa]

The water flow rate must be calculated with the following formula

$$Q [l/s] = kWf / (4,186 \times DT)$$

kWf = Cooling capacity in kW
 DT = Temperature difference between inlet / outlet water



To the internal exchanger pressure drops must be added the pressure drops of the mechanical steel mesh strainer that must be placed on the water input line. It is a device compulsory for the correct unit operation, and it is available as Clivet option. (See the HYDRONIC ASSEMBLY ACCESSORIES). If the mechanical strainer is selected and installed by the Customer, it is forbidden the use of filters with the mesh pitch higher than 1,6 mm, because they can cause a bad unit operation and also its serious damaging.

Admissible water flow rates

Min. (Qmin) and max. (Qmax) water flow-rates admissible for the correct unit operation.

Size		352	402	432	452	502	552	602	702	802
Qmin	[l/s]	2,3	2,6	2,9	3,2	3,6	3,9	4,4	4,9	5,5
Qmax	[l/s]	6,6	7,4	8,1	9,0	10,2	11,1	12,2	13,5	15,1

Premium version (EN)

General technical data (EN)

Acoustic Treatment: extremely low noise (EN)

Size			352	402	432	452	502	552	602	702	802
Cooling											
Cooling capacity	1	kW	87,0	95,9	105	115	126	136	153	178	193
Compressor power input	1	kW	29,9	35,3	39,9	42,1	45,7	51,6	59,8	64,3	74,4
Total power input	2	kW	32,4	37,8	42,4	44,6	48,2	54,1	62,3	67,8	77,9
Total recovery heating capacity	3	kW	114	129	144	155	169	186	208	238	263
Partial recovery heating capacity	3	kW	28,6	32,7	37,0	39,6	42,8	47,8	54,6	59,2	68,6
EER	1		2,69	2,54	2,48	2,58	2,62	2,51	2,45	2,62	2,48
Cooling capacity (EN14511:2013)	4	kW	86,5	95,3	105	114	125	135	152	177	192
Total power input (EN14511:2013)	4	kW	32,9	38,4	43,1	45,2	48,9	54,8	63,0	68,8	78,8
EER (EN 14511:2013)	4		2,63	2,48	2,43	2,53	2,56	2,47	2,41	2,57	2,44
SEER		8	3,80	3,81	3,80	3,98	3,90	3,82	3,80	3,93	3,80
Compressor											
Type of compressors			SCROLL	SCROLL	SCROLL	SCROLL	SCROLL	SCROLL	SCROLL	SCROLL	SCROLL
No. of compressors		No	2	2	2	2	2	2	2	2	2
Rated power (C1)		HP	35	40	43	45	50	55	60	70	80
Std Capacity control steps		No	3	3	3	3	3	3	2	3	2
Oil charge (C1)		l	8,00	10,0	12,0	10,0	11,0	13,0	13,0	13,0	13,0
Refrigerant charge (C1)	5	kg	18	18	22	24	27	27	32	39	39
Refrigeration circuits		No	1	1	1	1	1	1	1	1	1
Internal exchanger											
Type of internal exchanger	6		PHE	PHE	PHE	PHE	PHE	PHE	PHE	PHE	PHE
Water flow rate (Utility Side)	1	l/s	4,20	4,60	5,00	5,50	6,00	6,50	7,30	8,50	9,20
Internal exchanger pressure drops	1	kPa	40,7	41,7	43,9	41,2	37,2	38,5	41,2	39,5	42,5
Water content		l	4,80	5,50	6,10	6,90	8,00	8,90	10,1	11,9	14,2
Min. installation water contents	9	l	383	355	473	322	454	626	842	837	1081
External Section Fans											
Type of fans	7		AX	AX	AX	AX	AX	AX	AX	AX	AX
Number of fans		No	2	2	2	2	2	2	2	3	3
Standard air flow		l/s	10025	10025	10014	9986	9937	9937	10001	15015	15015
Connections											
Water connections			2" 1/2	2" 1/2	2" 1/2	2" 1/2	2" 1/2	2" 1/2	2" 1/2	2" 1/2	2" 1/2
Power supply											
Standard power supply		V	400/3/50	400/3/50	400/3/50	400/3/50	400/3/50	400/3/50	400/3/50	400/3/50	400/3/50
Dimensions											
A - Length		mm	2710	2710	2710	2710	2710	2710	3075	4025	4025
B - Width		mm	1097	1097	1097	1097	1097	1097	1097	1097	1097
C - Height		mm	1805	1805	1805	1805	1805	1805	1805	1805	1805
Standard unit weights											
Shipping weight		kg	773	796	885	917	955	975	1077	1283	1310
Operating weight		kg	778	802	892	924	963	984	1087	1295	1324

The Product is compliant with the Erp (Energy Related Products) European Directive. It includes the Commission delegated Regulation (EU) No 2016/2281, also known as Ecodesign LOT21.

Contains fluorinated greenhouse gases(GWP 2087,5)

1. Data referred to the following conditions: internal exchanger water = 12/7 °C external exchanger inlet air 35°C
2. The Total Power Input value does not take into account the part related to the pumps and required to overcome the pressure drops for the circulation of the solution inside the exchangers
3. Option. Recovery exchanger water = 40/45°C
4. Data calculated in compliance with Standard EN 14511:2013 referred to the following conditions: Internal exchanger water temperature = 12/7°C. External exchanger intake air temperature = 35°C
5. indicative values for standard units with possible +/-10% variation. The actual data are indicated on the label of the unit.
6. PHE = plates
7. AX = axial fan
8. Data calculated according to the EN 14825:2016 Regulation
9. The calculated water volume to the system does not consider the volume of water contained in the internal exchanger. With applications at low outdoor air temperature or low average loads requested, the minimum water volume to the system is obtained by increasing the indicated value by 40%.

Electrical data (EN)

Acoustic Treatment: extremely low noise (EN)

Size		352	402	432	452	502	552	602	702	802
F.L.A. - Full load current at max admissible conditions										
F.L.A. - Total	A	76,1	84,5	90,1	98,8	104,5	112,9	127,3	145,9	160,4
F.L.I. - Full load power input at max admissible conditions										
F.L.I. - Total	kW	44,2	49,0	54,4	57,8	63,2	68,0	76,8	89,6	100,2
M.I.C. Maximum inrush current										
M.I.C. - Value	A	264,9	311,6	317,2	349,6	355,2	363,6	378	466,1	480,6

Voltage unbalance: max 2 %

Power supply: 400/3/50 Hz +/- 10%

Electrical data refer to standard units; according to the installed accessories, the data can suffer some variations.

Operating range - Cooling (EN)

Acoustic Treatment: extremely low noise (EN)

Size		352	402	432	452	502	552	602	702	802
External exchanger										
Max inlet air temperature	1 °C	43	41	40	41	41	40	40	41	40
Max inlet air temperature	2 °C	45	44	43	44	44	43	42	44	43
Max inlet air temperature	3 °C	50	50	50	50	50	50	50	50	50
Min. inlet air temperature	4 °C	-10	-10	-10	-10	-10	-10	-10	-10	-10
Min. inlet air temperature	5 °C	-7,0	-7,0	-7,0	-7,0	-7,0	-7,0	-7,0	-7,0	-7,0
Min. inlet air temperature	6 °C	-2,0	-2,0	-2,0	-2,0	-2,0	-2,0	-2,0	-2,0	-2,0
Min. inlet air temperature	7 °C	11	11	11	11	11	11	11	11	11
Internal exchanger										
Max inlet water temperature	°C	24	24	24	24	24	24	24	24	24
Min. outlet water temperature	8 °C	5,0	5,0	5,0	5,0	5,0	5,0	5,0	5,0	5,0
Min. outlet water temperature	9 °C	-7,0	-7,0	-7,0	-7,0	-7,0	-7,0	-7,0	-7,0	-7,0

Data referred to the following conditions:

internal exchanger water = 12/7°C

air at rest

Caution: Air conditions which are at rest are defined as the absence of air flowing towards the unit. Weak winds can induce air to flow through the exchanger and air-levels which can cause a reduction in the operating range. In the presence of predominant winds it is necessary to use suitable windbreak barriers.

N.B. To ensure the correct maintenance (no operation) with outdoor air temperatures less than -10°C, the Standard unit (no FREE-COOLING configuration) must be equipped with the "Electrical panel anti-freeze protection" option and continue to be supplied with power. The hydraulic circuit must be filled with an adequate percentage of anti-freeze. In these conditions, the minimum outdoor air temperature which is permitted depends on the model of the "Electrical panel anti-freeze protection" option which has been chosen, up to a limit value of -39°C.

The operating mode can also be extended up to an outdoor air temperature of -25°C, but only in the FREE-COOLING configuration which is complete with an "Electrical panel anti-freeze protection" option of an adequate size.

The operating mode can be further extended to external air temperatures of 39°C. Only in the full FREE-COOLING configuration of the 'Device to reduce consumption of external section fans operating at variable speed (phase cut)' and 'Electrical panel antifreeze protection' of an adequate size.

In the Standard unit (no FREE-COOLING configuration) with an empty hydraulic circuit and without a power supply, correct maintenance (not operating) is possible up to an outdoor air temperature of -20°C.

1. Max. inlet air temperature - Unit at full load
2. Input air maximum temperature - Unit operating at full load with fans automatically forced at maximum speed (the sound levels in this particular operating condition are the same as the standard acoustic configuration SC)
3. Max. inlet air temperature - Unit at part load
4. Min. inlet air temperature - Unit at full load and outdoor air at rest

5. Min. inlet air temperature - Unit at part load and outdoor air at rest
6. Minimum input air temperature - Stepped unit and air speed at 0.5 m/s.
7. Minimum input air temperature - Stepped unit and air speed at 1 m/s
8. Standard unit without Low liquid temperature device and air entering the external exchanger at 35°C
9. Unit with Low liquid temperature device and air entering the external exchanger at 35°C. Fluid treated with 40% ethylene glycol.

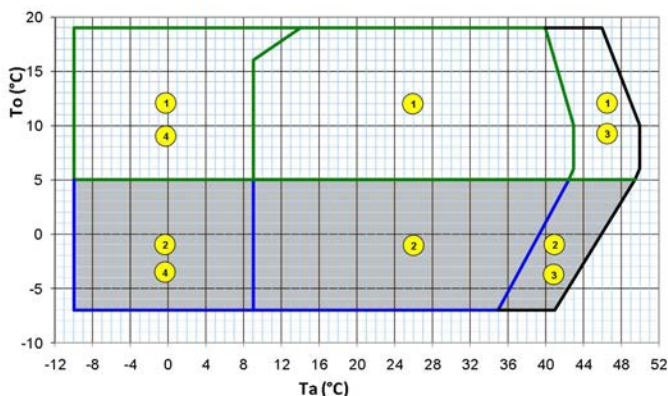

Graph referred to size 352

The detail of each size is shown in tabular date.

Ta (°C) = external exchanger inlet air temperature (dry bulb).
To (°C) = internal exchanger outlet water temperature

1. Standard unit: (no "Liquid low temperature" configuration)
2. Unit in "Low liquid temperature" configuration (40% ethylene glycol).
3. capacity-controlled unit (automatic capacity control)
4. Unit at full load: (automatic modulation of the air flow rate)

Performances in cooling (EN)

Acoustic Treatment: extremely low noise (EN)

Size	To (°C)	External exchanger input air temperature (°C)											
		25		30		32		35		38		40	
		kWf	kWe	kWf	kWe	kWf	kWe	kWf	kWe	kWf	kWe	kWf	kWe
352	5	92	24,5	87	26,8	85	27,8	81,8	29,3	78,6	30,9	76,5	32
	6	94,9	24,7	89,7	27,1	87,6	28,1	84,4	29,6	81,2	31,2	79	32,2
	7	97,8	25	92,5	27,4	90,3	28,3	87	29,9	83,6	31,4	81,4	32,5
	8	100,5	25,3	95,2	27,6	93	28,6	89,6	30,1	86,1	31,7	83,7	32,8
	9	103,2	25,6	98	27,9	95,8	28,9	92,2	30,4	88,5	32,1	85,9	33,2
	10	105,8	26	100,8	28,2	98,5	29,1	94,9	30,7	90,9	32,4	88	33,7
402	5	102,7	29,1	96,8	31,8	94,5	32,9	91,3	34,5	88,2	36,1	86,2	37,1
	6	105,8	29,4	99,3	32,1	96,9	33,2	93,5	34,9	90,2	36,6	88,2	37,7
	7	108,6	29,7	102	32,5	99,5	33,6	95,9	35,3	92,4	37	90,2	38,1
	8	111,4	30	104,8	32,8	102,2	33,9	98,5	35,6	94,8	37,2	92,4	38,3
	9	114	30,5	107,7	33,3	105,1	34,3	101,2	35,9	97,2	37,4	94,6	38,4
	10	116,5	31	110,7	33,7	108,2	34,7	104,2	36,1	99,9	37,5	96,8	38,3
432	5	112,2	32,6	106,1	35,7	103,5	37,1	99,5	39,1	95,4	41,3	92,6	42,8
	6	115,1	33,2	109,3	36,1	106,7	37,4	102,3	39,5	97,5	41,8	94	43,5
	7	118,2	33,7	112,4	36,5	109,7	37,8	105,3	39,9	100,4	42,1	97	43,7
	8	121,7	34	115,2	37	112,6	38,3	108,5	40,3	104,3	42,3	101,4	43,7
	9	125,5	34,3	117,9	37,6	115,3	38,9	111,8	40,6	108,9	42,3	107,3	43,3
	10	129,7	34,5	120,4	38,3	117,9	39,5	115,4	41	114,4	42,1	114,6	42,6
452	5	122	34,5	115,5	37,8	112,9	39,1	109,1	41,1	105,3	43	102,8	44,3
	6	125,5	34,9	118,7	38,3	116	39,6	112	41,6	108,1	43,6	105,6	44,9
	7	129,2	35,3	122,1	38,7	119,2	40,1	115,1	42,1	110,9	44,1	108,2	45,5
	8	132,9	35,7	125,7	39,1	122,7	40,4	118,2	42,5	113,7	44,6	110,7	46
	9	136,7	36,2	129,4	39,4	126,4	40,8	121,5	42,8	116,5	45	113	46,5
	10	140,7	36,7	133,4	39,7	130,2	41	124,9	43,1	119,3	45,3	115,2	46,9
502	5	133,7	37,1	126,5	40,9	123,6	42,5	119,1	44,9	114,5	47,5	111,4	49,2
	6	137,3	37,6	130,2	41,2	127,2	42,7	122,5	45,2	117,6	47,9	114,3	49,8
	7	141,1	38,1	134	41,6	130,9	43,1	126	45,7	120,8	48,4	117,2	50,4
	8	145,2	38,6	137,8	42,1	134,6	43,7	129,5	46,2	124,1	49	120,3	51
	9	149,6	39,1	141,8	42,7	138,4	44,3	133,1	46,9	127,4	49,6	123,4	51,5
	10	154,2	39,6	145,9	43,5	142,3	45,1	136,7	47,6	130,7	50,2	126,5	52
552	5	144,6	42,2	136,4	46,3	133,1	48	128,3	50,6	123,6	53,3	120,4	55,1
	6	149	42,8	140,8	46,8	137,4	48,5	132,1	51,1	126,5	53,9	122,7	55,9
	7	153,3	43,4	145,1	47,3	141,6	48,9	136	51,6	130,1	54,4	125,9	56,4
	8	157,4	44	149,2	47,8	145,6	49,4	140	52	134,1	54,7	130	56,6
	9	161,4	44,5	153,1	48,4	149,6	50	144,3	52,4	138,8	54,9	135,1	56,6
	10	165,3	45	156,7	49	153,4	50,6	148,6	52,8	144	54,9	141	56,3
602	5	161,5	49	153	53,6	149,3	55,6	143,5	58,7	137,5	62	133,2	64,3
	6	166,1	49,7	157,5	54,3	153,9	56,3	148,3	59,2	142,4	62,2	138,4	64,3
	7	170,8	50,3	162	55	158,3	56,9	152,7	59,8	146,9	62,7	142,9	64,6
	8	175,8	50,9	166,5	55,6	162,7	57,5	156,8	60,4	150,9	63,3	146,8	65,2
	9	180,9	51,5	171	56,2	166,9	58,1	160,7	61,1	154,3	64,1	150	66,1
	10	186,3	52	175,5	56,7	171	58,7	164,2	61,8	157,3	65,1	152,6	67,4
702	5	187,9	52,4	178,3	57,5	174,5	59,6	168,9	62,8	163,3	66	159,7	68,2
	6	193	53	183,2	58,1	179,2	60,2	173,2	63,6	167,1	67,1	162,9	69,5
	7	198,3	53,5	188,2	58,6	184,1	60,8	177,8	64,3	171,4	67,9	167	70,4
	8	203,9	54,2	193,3	59,2	189,1	61,4	182,7	64,9	176,2	68,6	171,9	71,1
	9	209,8	54,8	198,5	59,9	194,1	62	187,8	65,4	181,6	69,1	177,6	71,6
	10	216	55,6	203,8	60,5	199,3	62,6	193,1	65,9	187,5	69,4	184,1	71,8
802	5	202,3	61	193	66,4	188,8	68,9	182,3	72,8	175,2	77	170,3	80,1
	6	208,5	61,5	197,4	67,5	193,4	69,9	187,7	73,6	182,5	77,2	179,3	79,6
	7	214,7	62,1	202,6	68,4	198,5	70,8	193,1	74,4	188,7	77,8	186,2	80
	8	221,1	62,7	208,5	69,1	204,2	71,6	198,4	75,2	193,6	78,8	190,9	81,1
	9	227,5	63,4	215,1	69,6	210,4	72,1	203,7	76,1	197,3	80,2	193,3	83,1
	10	234	64,2	222,3	69,8	217,1	72,5	208,8	77	199,9	82,1	193,6	85,8

kWf = Cooling capacity in kW

The data do not consider the pump share, required to overcome the pressure drop for the solution circulation inside the exchangers

kWe = Electrical power absorbed by compressors (kW)

To = Leaving water temperature on hydraulic circuit, cooling side (°C), load input/output = 5°C

Sound levels (EN)

Acoustic Treatment: extremely low noise (EN)

Size	Sound power level (dB)								Sound power level	Sound pressure level
	Octave band (Hz)									
	63	125	250	500	1000	2000	4000	8000	dB(A)	dB(A)
352	83	84	85	80	72	69	60	55	81	63
402	82	83	84	80	74	70	62	57	81	63
432	82	83	86	81	75	71	62	56	82	65
452	83	83	85	82	76	70	63	57	83	65
502	81	83	86	82	75	70	62	55	83	65
552	82	83	87	83	77	72	64	58	84	66
602	82	83	86	83	78	71	64	57	84	66
702	85	85	88	85	79	73	65	59	86	67
802	84	85	88	85	79	73	65	59	86	67

Sound levels refer to full load units, in test nominal conditions. The sound pressure level refers to 1 m. from the unit outer surface operating in open field. Measures according to UNI EN ISO 9614-2 regulations, with respect to the EUROVENT 8/1 certification.

Data referred to the following conditions:
 internal exchanger water = 12/7°C
 outdoor air temperature 35°C

The indicated sound levels are only valid within the operating field of the unit in the "Supersilenced EN" configuration; with fresh air temperatures which are higher and in any case within the operating field of the "Soundproofed Compressors SC" configuration bearing in mind the sound levels of the unit in the "Soundproofed Compressors SC" configuration.

Internal exchanger pressure drops

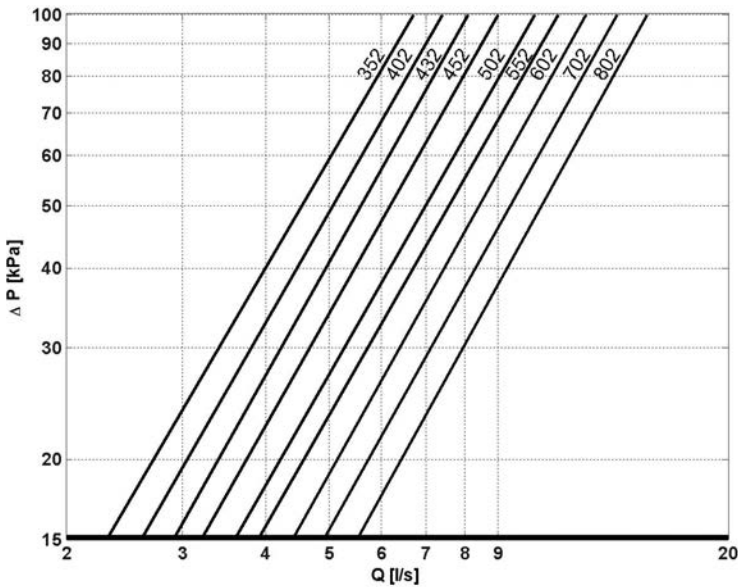

The pressure drops on the water side are calculated by considering an average water temperature at 7°

Q = water flow rate (l/s)
 DP = pressure drop (kPa)

The water flow rate must be calculated with the following formula

$$Q [l/s] = kWf / (4,186 \times DT)$$

kWf = Cooling capacity in kW
 DT = Temperature difference between inlet / outlet water



To the internal exchanger pressure drops must be added the pressure drops of the mechanical steel mesh strainer that must be placed on the water input line. It is a device compulsory for the correct unit operation, and it is available as Clivet option. (See the HYDRONIC ASSEMBLY ACCESSORIES). If the mechanical strainer is selected and installed by the Customer, it is forbidden the use of filters with the mesh pitch higher than 1,6 mm, because they can cause a bad unit operation and also its serious damaging.

Admissible water flow rates

Min. (Qmin) and max. (Qmax) water flow-rates admissibles for the correct unit operation.

Size	352	402	432	452	502	552	602	702	802
Qmin [l/s]	2,3	2,6	2,9	3,2	3,6	3,9	4,4	4,9	5,5
Qmax [l/s]	6,6	7,4	8,1	9,0	10,2	11,1	12,2	13,5	15,1

Configurations

Consult the special prospective reported in the final section to check for compatibility between different options.

B - Low water temperature

Configuration also known as “Brine”. Enables an “unfreezable” solution to be cooled (for example, water and ethylene glycol in suitable quantities) up to a temperature of between +4°C and -7°C.

It includes:

- suitable exchangers with extra-thick closed-cell insulation
- electronic expansion valve, functional calibration and safety devices suitable for particular uses.

During the selection phase it is necessary to indicate the required operating type, the unit will be optimised on the basis of this: - Unit with single operating set-point (only at low temperature) - Unit with double operating set-point

The unit in this configuration has a different operation range, indicated in the operating range section.

In low temperature operation, some staging steps could not be available.

The glycol concentration must be chosen based on the minimum temperature the water can reach. The presence of glycol influences pressure drops on the water side and the unit's output as indicated in the table reporting the “correction factors for use with glycol”.

D - Partial energy recovery

A configuration which enables the production of hot water free-of-charge while operating in the cooling mode, thanks to the partial recovery of condensation heat that would otherwise be disposed of into the external heat source.

This option is also known as “desuperheater”. It is made up of a Inox 316 stainless steel brazed plate heat exchangers, suitable for recovering a part of the capacity dispersed by the unit (the dispersed heating capacity is equal to the sum of the cooling capacity and the electrical input capacity of the compressors).

The partial recovery device is considered to be operating when it is powered by the water flow which is to be heated. This condition improves the unit performance, since it reduces the condensation temperature: in nominal conditions the cooling capacity increases indicatively by 3.2% and the power input of the compressors is reduced by 3.6%.

When the temperature of the water to be heated is particularly low, it is opportune to insert a flow regulation valve in the hydraulic circuit, to maintain the recovery output temperature at higher than 35°C and thus avoid refrigerant condensation in the partial energy recovery device.

The power delivered by the partial recovery is 20% of the thermal power dissipation (cooling + electrical power absorbed by the compressors)

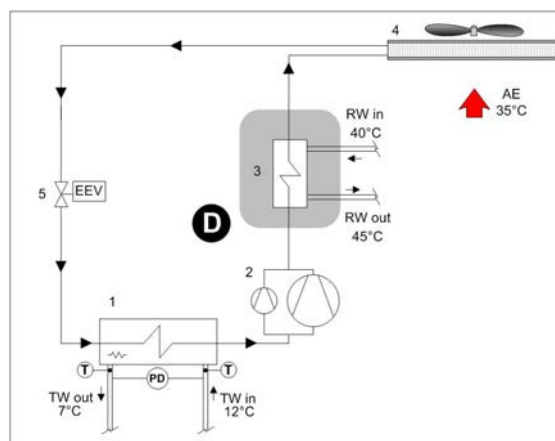

D - Partial recovery device

- 1 - Internal exchanger
- 2 - Compressors
- 3 - Recovery exchanger
- 4 - External exchanger
- 5 - Expansion electronic valve

- TW in chilled water inlet
- TW out chilled water outlet
- RW in - Recovery water input
- RW out - Recovery water output
- T - Temperature probe
- PD - Differential pressure switch
- AE Outdoor air

Pressure drops of partial energy recovery exchanger

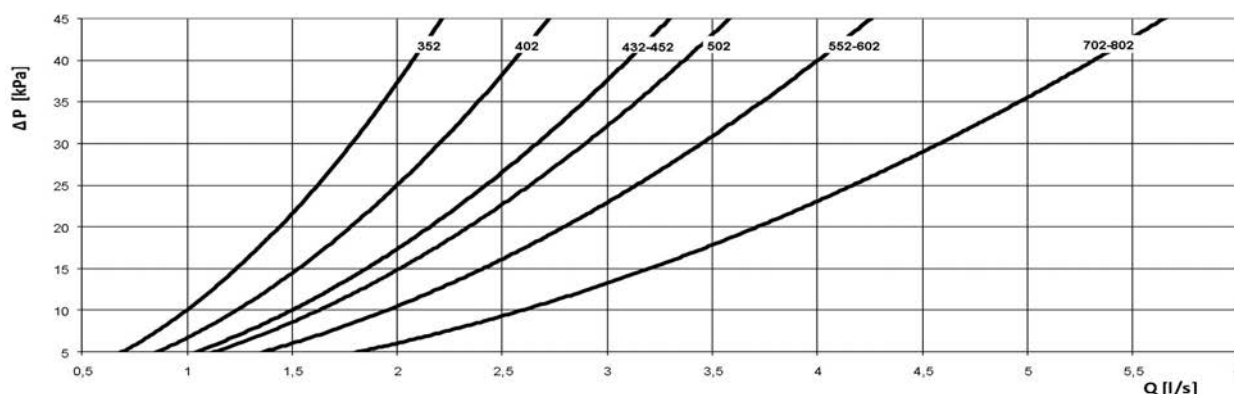

Q = Water-flow rate [l/s]
 DP = Pressure drops [kPa]

R - Total energy recovery

A configuration which enables the production of hot water free-of-charge while operating in the cooling mode, thanks to the total recovery of condensation heat that would otherwise be disposed of into the external heat source. This solution increases the overall efficiency of the system in all cases where a high-level of hot water production is required. It is made up of a brazed plate heat exchanger made of 316 stainless steel, suitable for recovering all the unit heat capacity (equal to the sum of the cooling capacity and the electrical input capacity of the compressors), from the on-off type solenoid valve, from the supply and return temperature sensors in the hot water circuit and the related two-step integrated control logic.

Hot water availability is always subordinate to the production of chilled water.

See the following example:

1. cooling capacity request = 100% / Heating capacity request = 0% >Production only of cooling capacity;
2. cooling capacity request = 100% / Heating capacity request = 0% >Production of cooling and heating capacity by recovery;
3. cooling capacity request = 50% / Heating capacity request = 100% >Production of cooling and heating capacity by recovery, equal to the 50% of the requested heating capacity.



To prevent constant switching in the unit's refrigeration circuit, it is necessary to install a storage tank with an adequate capacity in the system's hot water circuit.



In the absence of hot water circulation in the recovery exchanger, the maximum inlet air temperature is reduced by approximately 2°C compared with the unit without "Total Energy Recovery" mode.

TOTAL OPERATING ENERGY RECOVERY

When hot water is requested, the condensing coil is deactivated. Condensation takes place wholly within the recovery circuit.

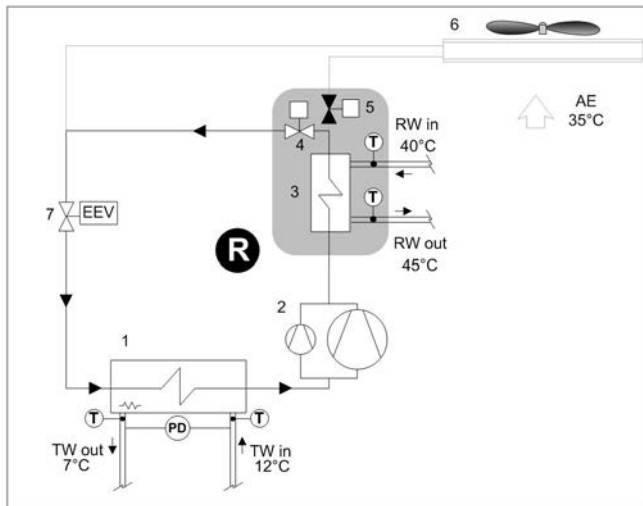

TOTAL NON-OPERATING ENERGY RECOVERY

When the recovery set-point has been satisfied, the condensing coil is reactivated. In this condition, the total recovery circuit operates as a Partial recovery circuit (Desuperheater).

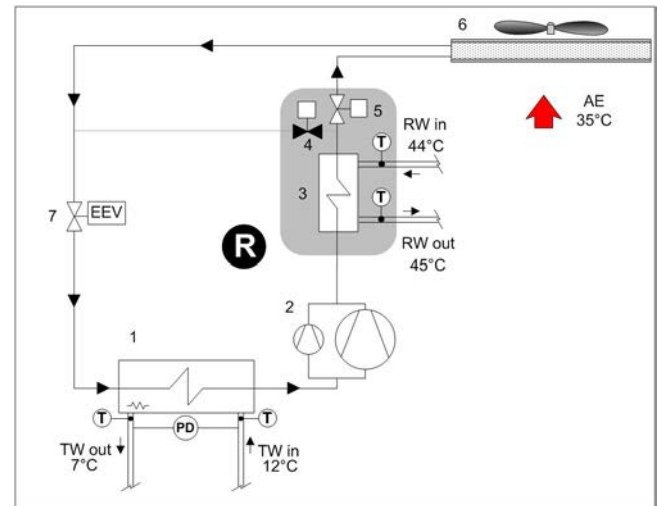

- R - Total recovery device
- 1 - Internal exchanger
- 2 - Compressors
- 3 - Recovery exchanger
- 4 - Total recovery enabling valve

- 6 - External exchanger
- 7 - Expansion electronic valve
- T - Temperature probe

- TW in chilled water inlet
- TW out chilled water outlet
- RW in - Recovery water input
- RW out - Recovery water output
- AE Outdoor air

Pressure drops of the total energy recovery exchanger

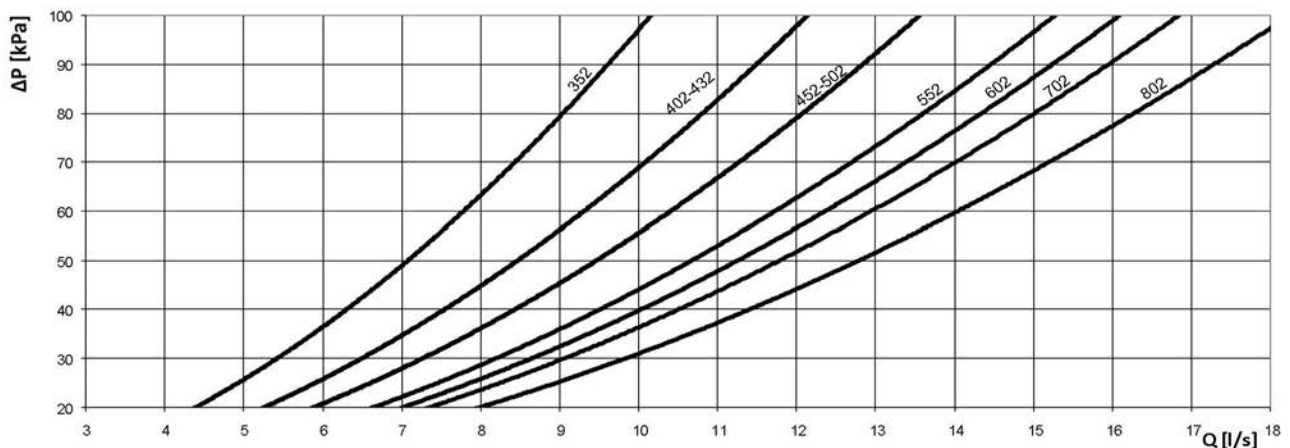

Q = Water-flow rate [l/s]
DP = Pressure drops [kPa]

FCD - Direct FREE-COOLING

Configuration that allows for considerable savings on the system's running costs in applications that require chilled water also during the cold season, such as industrial processes, data centres, telecommunications, technological applications and shopping centres.

When the external air temperature is lower than the temperature of the system's return water, the FREE-COOLING system recovers cold from the external environment and reduces the operation of the compressors until they stop completely.

The higher the temperature of the chilled water in the system (e.g. 10-15°C instead of 7-12°C), the greater the operating range of the FREE-COOLING system and, therefore, the higher the energy savings.

Use of anti-freeze solutions

The FREE-COOLING configuration is particularly indicated in buildings where, at least in certain periods of the year, the temperature of the outdoor air also reaches very low values. For this reason the liquid must be protected from the risk of freezing, typically using the addition of a suitable anti-freeze substance such as ethylene glycol. The percentage of glycol in the solution depends on the minimum temperature value foreseen in the installation zone, and is in any case within the fundamental parameters of the plan for the system.

Technical description

Compared with standard units, Clivet units in the direct FREE-COOLING configuration also include:

- a three-way switching valve with on/off adjustment
- air-water finned coil exchanger (FREE-COOLING coil)
- additional external air temperature sensor and dedicated adjustment logic
- flush hydraulic connections

Management logic

There are three main operating modes, which basically differ in terms of position of the three-way switching valve and the number of active compressors.

(A) Summer

In the summer season, with outdoor air temperatures which are greater than the return temperature of the liquid in the system, the three-way valve is switched in such a way as to exclude the FREE-COOLING coils. The cooling of the liquid is referred to the direct expansion circuit, with the intervention of the compressors as in a traditional chiller.

(B) Intermediate season

In the winter season, or rather with the outdoor air temperature at a little below the return water temperature of the system, when the unit identifies that the temperature conditions are favourable:

- switches the position of the tree-way valve, forcing the solution to transit through the FREE-COOLING coils before reaching the evaporator
- brings the fans to maximum speed to make the most of the cooling of the solution carried out by the external air
- conducts a first cooling of the solution in a 'natural way and free of charge'
- provides the capacity required via the cooling circuit using compressors with partial operation (capacity absorbed proportional to the partialisation level)

If the outdoor air temperature should increase, the microprocessor automatically converts the operating mode to the summer mode, guaranteeing the conditions requested by the user at all times.

(C) Winter

In the winter season, with the outdoor air temperature below the return water temperature of the system, the unit identifies that the temperature conditions are favourable for operating in FREE-COOLING mode:

- the 3-way valve is switched like in the previous case, forcing the solution to transit through the FREE-COOLING coils before reaching the evaporator.
- the external air temperature brings the solution at the outlet of the FREE-COOLING coils already at the temperature required by the utility
- the microprocessor control completely deactivates all the compressors which supply all the requested cooling capacity at no cost, in contrast to traditional chillers

The difference between the outdoor air temperature and that requested for use could also be such as to lower the temperature of the solution at the output of the FREE-COOLING coils to below the set-point requested for use. This is a condition which does not prejudice the safety of the unit thanks to the presence of anti-freeze in the solution. The microprocessor modulates fan speed up to the point where they are switched off. If, with all the fans switched, off the temperature continues to decrease, the three-way valve positions itself automatically in the summer operational mode, thus enabling the requested set-point to be maintained.

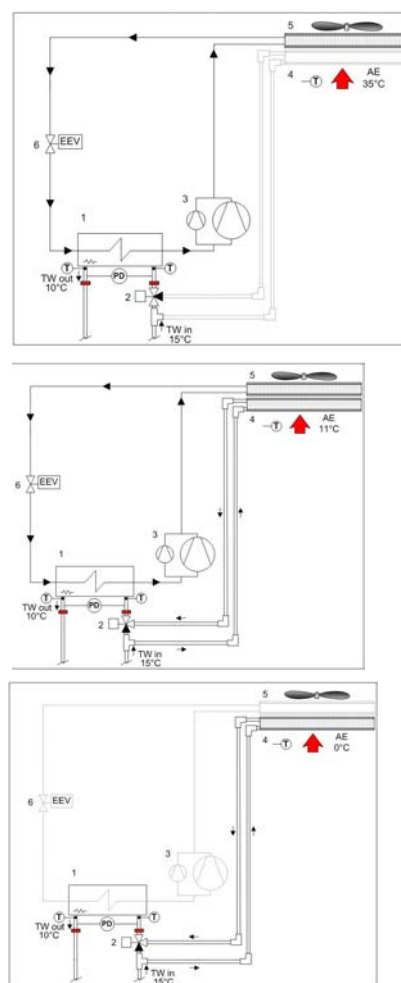

D - Partial recovery device

3 - Compressors

TW in chilled water inlet

1 - Internal exchanger

4 - External exchanger

TW out chilled water outlet

2 - Three-way valve for Free-Cooling

5 - External fan

6 - Expansion electronic valve

AE Outdoor air

Unit performance with direct free-cooling configuration

The unit performance in the direct FREE-COOLING configuration also depends on the quantity of anti-freeze in the circuit being used and is reported to follow in the two main operating modes.

Operating modes direct FREE-COOLING deactivated

The performance of the standard units is considered in the requested conditions and the following corrective coefficients are applied.

Percentage in Ethylene Glycol weight	10%	20%	30%	40%
Cooling Capacity Factor	0,97	0,96	0,95	0,94
Compressor absorbed Capacity Factor	1.040	1.034	1.030	1.027

Example:

Determine the performances of the following unit: WSAT-XEE FCD 702 SC EXC (EXCELLENCE version, direct FREE-COOLING configuration), with Water 15/10 °C / 30% glycol / Outdoor air 35°C

Reference:

WSAT-XEE 702 SC EXC - Cooling capacity = 213,9 kW / Compressor electric power = 57,3 kW

Calculation:

WSAT-XEE FCD 702 SC EXC (direct FREE-COOLING) - Cooling capacity = 213,9 x 0,95 = 203,2 kW / Compressor electric power = 56,9 x 1,03 = 59,0 kW

Operating modes: direct FREE-COOLING activated

Size (SC/EN version)		352	402	432	452	502	552	602	702	802
Free-cooling (1) nominal capacity	kW	101	113	126	136	148	160	181	204	227
Temperature with FREE-COOLING at 100% (1)	°C	0,5	-0,5	-2,0	0,0	-0,5	-1,0	-2,5	0,0	-2,5

(1) Data refer to the following conditions:
 - water temperature: 15°C inlet / 10°C outlet
 - glycol percentage 30%

When the outdoor air temperature increases, FREE-COOLING cooling capacity is lowered (at par return water temperature in the system). If the cooling capacity required by the system is known, the maximum fresh air temperature can be calculated to enable such cooling capacity to be available via FREE-COOLING. Below this temperature, only the requested capacity is supplied thanks to modulations in the air flow from the fans.

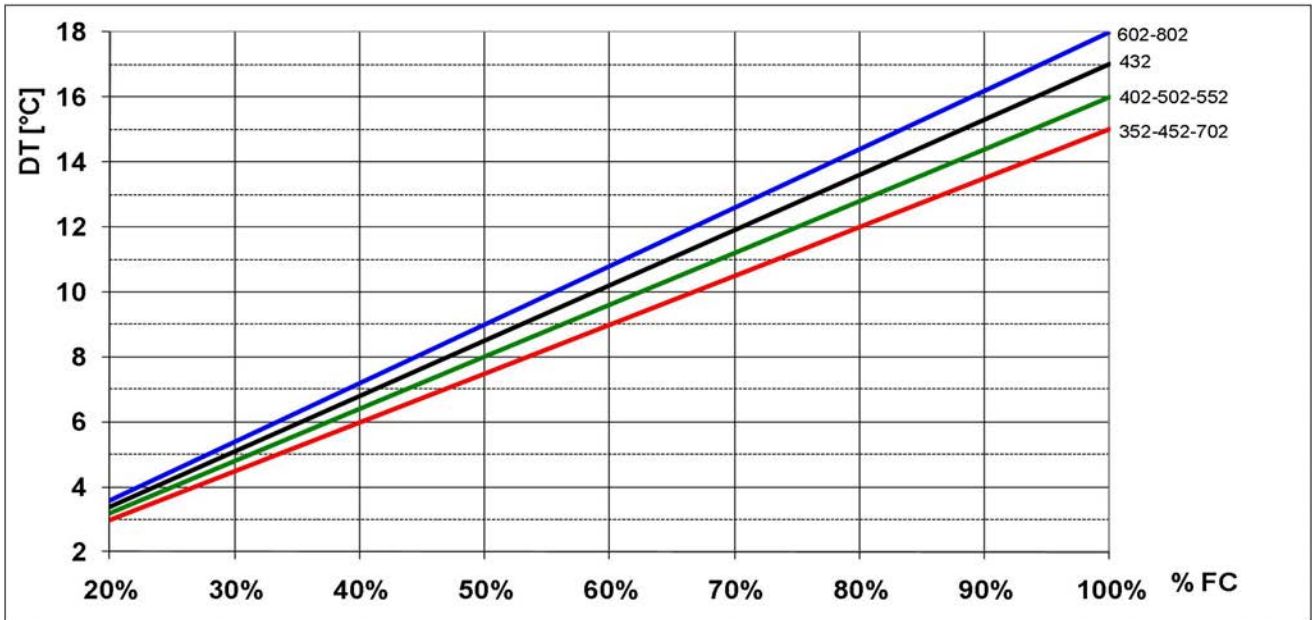

KEY
 DT Temperature difference between the system return water and the external air
 %FC FREE-COOLING percentage (in relation to the rated FREE-COOLING capacity)
 Example:

Determine the performances with outdoor air = +1°C for the following unit: WSAT-XEE FCD 702 SC EXC EXCELLENCE version, direct FREE-COOLING configuration), with water 15/10 °C / 30% glycol.

Reference:

WSAT-XEE FCD 702 SC EXC - FREE-COOLING nominal capacity = 203 kW (from table - with water 15/10 °C / 30% glycol / outdoor air temperature 0°C)

Calculation:

Difference between the installation return water and the outdoor air = 15°C - 1°C = 14°C

The graph shows that: FREE-COOLING percentage = 93% - FREE-COOLING capacity at +1°C outdoors = 203 x 93% = 188.8 kW

Accessories - hydronic assembly

1PUS - Standard pump

Option supplied on the unit. Centrifugal electric pump with pump body and impeller made with AISI 304 stainless steel. Mechanical seal by means of components made of ceramics, carbon and EPDM elastomers. Three-phase electric motor with IP55 protection rating. Complete with a thermoformed insulating casing, quick couplings with an insulated casing, a check valve, a safety valve, pressure gauges, a system safety pressure switch, stainless steel, antifreeze, intake and supply, immersion-type heaters.

The various models which are available can be differentiated by the system available pressure.

1PU1SB - Standard pump with standby pump

Option supplied on the unit. Two centrifugal electric pumps, one of which in stand-by, with AISI 304 stainless body and impeller. Mechanical seal by means of components made of ceramics, carbon and EPDM elastomers. Three-phase electric motor with IP55 protection rating. Complete with a thermoformed insulating casing, quick couplings with an insulated casing, a check valve, a safety valve, pressure gauges, a system safety pressure switch, stainless steel, antifreeze, intake and supply, immersion-type heaters. The microprocessor control balances the hours of operation and, in the event of malfunctions, it indicates the failure and automatically activates the standby pump.

The various models which are available can be differentiated by the system available pressure.



The 1PUS and 1PU1SB options are supplied as standard with the hydraulic connection kit on the system's return line (for installation outside the unit, to be provided by the Customer). The kit consists of: -no. 1 cast-iron shut-off butterfly valve equipped with throttle drive and mechanical calibration stop - no. 1 quick coupling

A300/A500 - 300/500 litres storage tank

Option supplied built-in the unit. Steel storage tank complete with double layer covering with closed-cell insulation, stainless steel anti-freeze immersion resistance, bleed valve, draw off cock, cast-iron shut-off butterfly valve with quick connections and activation lever with a mechanical calibration lock at the evaporator output, quick connections with insulated casing.

The various available models can be differentiated by capacity.



The A300 and A550 options are supplied as standard with the hydraulic connection kit on the system's return line (for installation outside the unit, to be provided by the Customer). The kit consists of: -no. 1 cast-iron shut-off butterfly valve equipped with throttle drive and mechanical calibration stop - no. 1 quick coupling

STANDARD PUMP / STANDARD PUMP WITH STANDBY PUMP

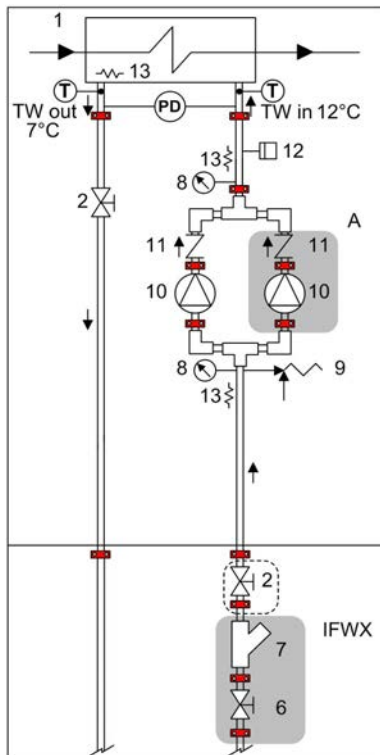

STORAGE TANK

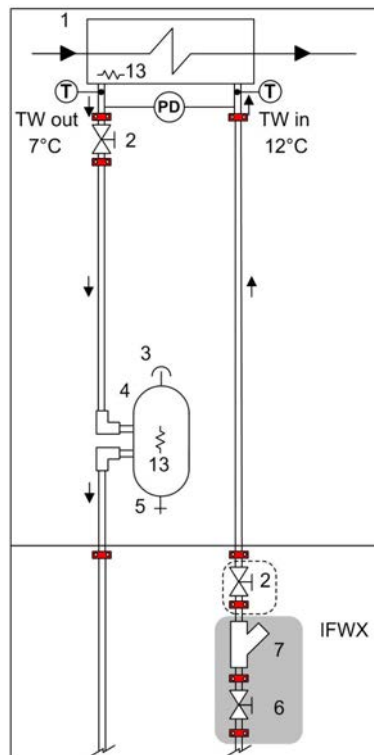

STANDARD PUMP / WITH RESERVE PUMP AND STORAGE TANK

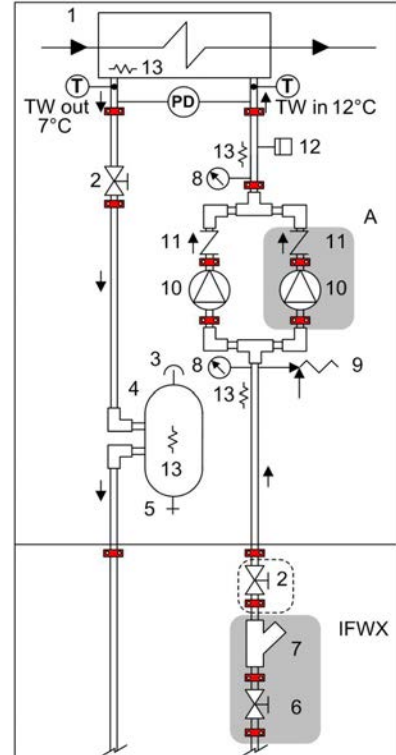

- 1 - Internal exchanger
- 2 - Cutoff valve
- 3 - Purge valve
- 4 - Storage tank with antifreeze heater
- 5 - Draw off cock
- 6 - Cutoff valve with quick joints

- 7 - Steel mesh strainer water side
- 8 - Manometer
- 9 - Safety valve (6 Bar)
- 10 - Packaged electric pump with high efficiency impeller
- 11 - Non return valve
- 12 - System safety pressure switch (prevents the pumps from operating if no water is present)

- TW in chilled water inlet
- TW out chilled water outlet
- IFWX = Steel mesh strainer water side

Water connection kit supplied as standard
The grey area indicates further optional components.

1PUS / 1PU1SB option performances

Version: Excellence

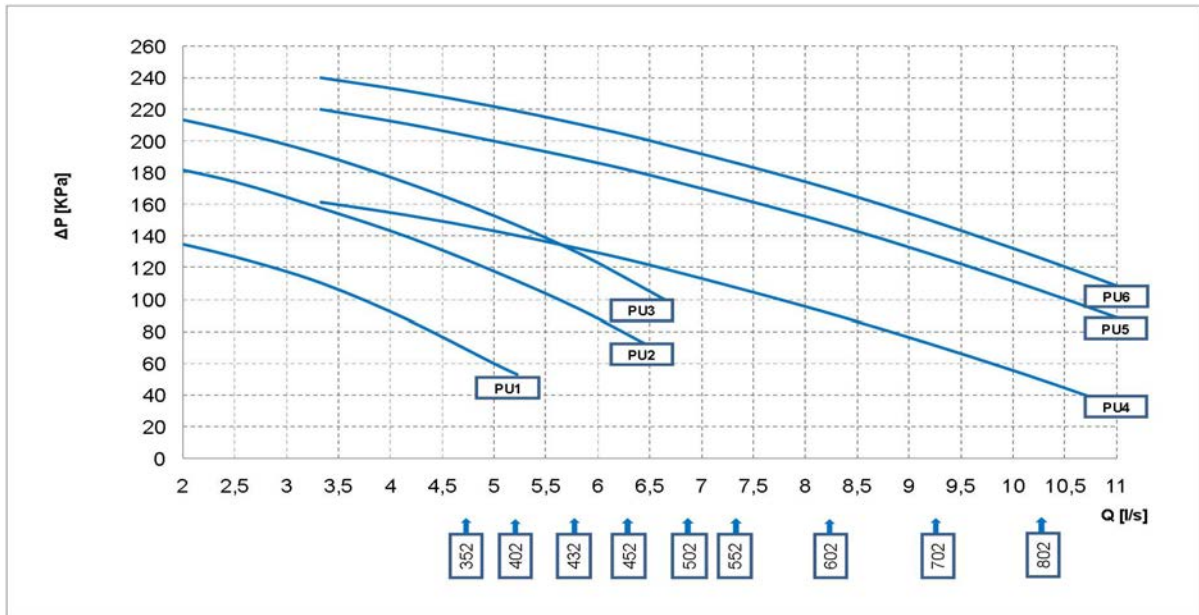

Q = Water-flow rate [l/s]
 DP = Pressure drops [kPa]

Version: Premium

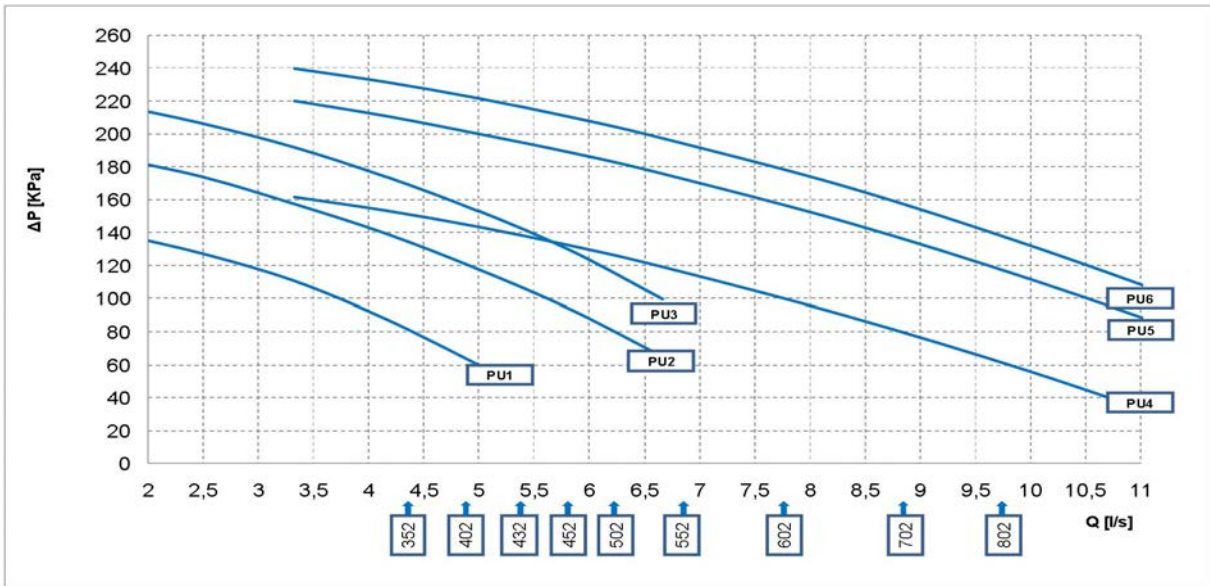

Q = Water-flow rate [l/s]
 DP = Pressure drops [kPa]



Caution: to obtain the available pressure values, you need to subtract the following from the head values represented in these diagrams:
 -Evaporator pressure drops
 -IFVX accessory -Steel mesh filter on the water side (where applicable)

Single Pump Technical Specifications

PUMP	Rated power [kW]	Nominal power [A]
PU1	1,4	2,6
PU2	1,4	2,6
PU3	1,8	3,2
PU4	1,8	3,4
PU5	2,9	4,8
PU6	3,3	5,6

A300RPS/A500RPS - 300/500 litres storage tank with primary circuit built-in

Option supplied built-in. Simplifies system design and manufacture.

Available only when the '1PUS - Standard pump' or '1PU1SB - Standard pump with standby pump' option is present, this accessory includes the components provided for the A300 / A450 / A500 / A550 option, as well as:

- primary circuit, already set up and tested inside the unit;
- cast-iron butterfly shut-off valve, with quick connections and activating handle and mechanical calibration lock in evaporator outlet and on the pump supply.



A300RPS and A500RPS options are available only with the "Low head pump" option.

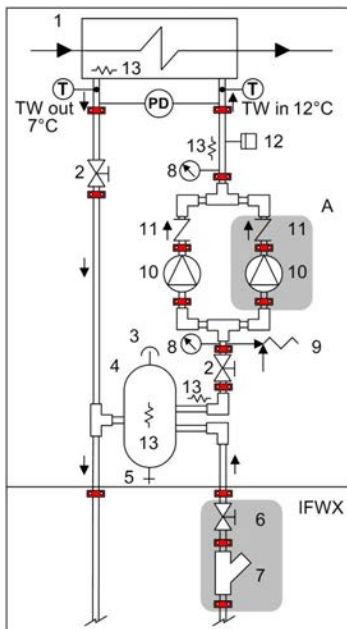

- 1 - Internal exchanger
- 2 - Cutoff valve
- 3 - Purge valve
- 4 - Storage tank with antifreeze heater
- 5 - Draw off cock
- 6 - Cutoff valve with quick joints
- 7 - Steel mesh strainer water side
- 8 - Manometer
- 9 - Safety valve (6 Bar)
- 10 - Packaged electric pump with high efficiency impeller
- 11 - Non return valve
- 12 - System safety pressure switch (prevents the pumps from operating if no water is present)
- 13 - Antifreeze heater

IFWX = Steel mesh strainer water side

TW in chilled water inlet
TW out chilled water outlet

The grey area indicates further optional components.

l f



the water flow rate on the primary circuit is greater than the one on the secondary circuit, this allows to directly control the supply temperature to the secondary one. Vice versa, if the water flow rate on the primary circuit is lower than the one on the secondary circuit, this means the supply water is mixed with the system's return water and therefore there is no direct control over the temperature of the chilled water produced

IFWX - Steel mesh strainer water side

The device stops the exchanger from being clogged by any impurities which are in the hydraulic circuit. The mechanical steel mesh strainer must be placed on the water input line. It can be easily dismantled for periodical maintenance and cleaning. It also includes:

- cast-iron shut-off butterfly valve with quick connections and activation lever with a mechanical calibration lock;
- quick connections with insulated casing.

STEEL KNIT FILTER PRESSURE DROP

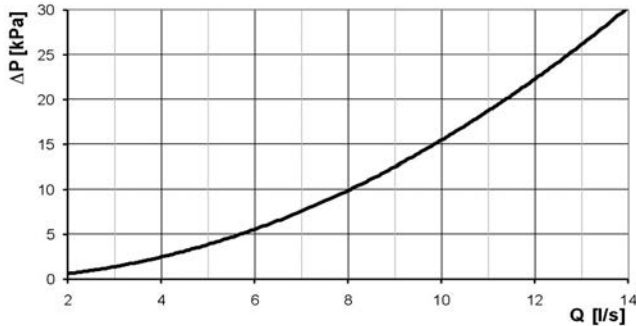

Q = water flow rate (l/s)
DP = water side pressure drops (kPa)



Pressure drop referred to a clean filter



Installation is the responsibility of the Client, externally to the unit.



Check for the presence of the required hydraulic shut-off valves in the system, in order to undertake periodical maintenance.

Accessory separately supplied

ABU - Flush hydraulic connections

An option which simplifies the hydraulic connections which would otherwise be carried out within the unit (with the responsibility of the client).

Includes internal piping to the external unit panel, two quick connections flush to the unit, two outlet connections for the system connections which are to be soldered by the client.

The accessory is provided and installed built-in the unit.

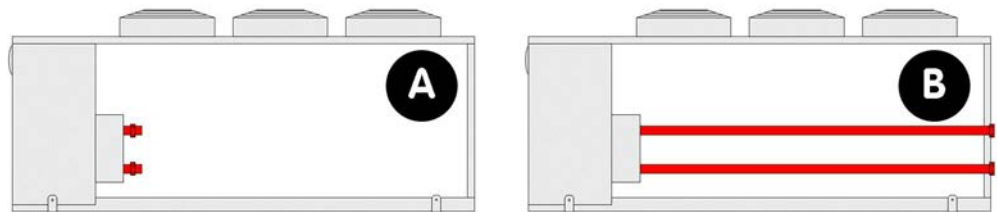

A - Standard unit
B - Unit with ABU option

Main diagram, not to scale



IMPORTANT!

The water connections flush with the unit are supplied as standard in units which are complete with at least one of the following options:

- Direct FREE-COOLING configuration
- Standard pump / Standard pump with standby pump
- Storage tank
- Storage tank with primary circuit built-in
- HYDROPACK



GENERAL NOTE

It is also advisable to provide the system with the following components, which are excluded from the Clivet supplies:

- Shut-off valves, if not included in Clivet's supply
- Devices to support pipes and anti-vibration elastic joints
- Expansion tank (e.g. for closed-circuit systems)
- Control thermostat on supply
- Additional vents and drains where necessary

HydroPack

2PM - Hydropack with 2 pumps

Option supplied on the unit. Pumping unit consisting of two parallel electric pumps with a self-adaptive modular activation logic.

It enables the automatic reduction of the liquid flow rate in critical conditions, avoiding blocks due to overloading and consequential intervention work by specialised technical personnel.

Centrifugal electric pump, with body and impeller made with AISI 304 steel.

Mechanical seal using ceramic, carbon and EPDM elastomer components.

Three-phase electric motor with IP44-protection. Complete with thermoformed insulated casing, quick connections with insulated casing, non return valve, safety valve, pressure gauges, system load safety pressure switch, stainless steel antifreeze immersion heaters located at the return and supply point.

The various models which are available can be differentiated by the system available pressure.

The 2PM option is supplied as standard with the hydraulic connection kit on the system's return line (for installation outside the unit, to be provided by the Customer). The kit consists of: no. 1 cast-iron shut-off butterfly valve equipped with throttle drive and mechanical calibration stop; no. 1 quick coupling

The 2PM option is supplied with a kit made up of 2 quick blind connections, for the removal of one pump in case of maintenance.

The 2PM option is: compatible with the A300 / A500 option - 300 / 500 litre storage tank; not compatible with the A300RPS / A500RPS option- 300 / 500 litre storage tank with primary circuit in the unit

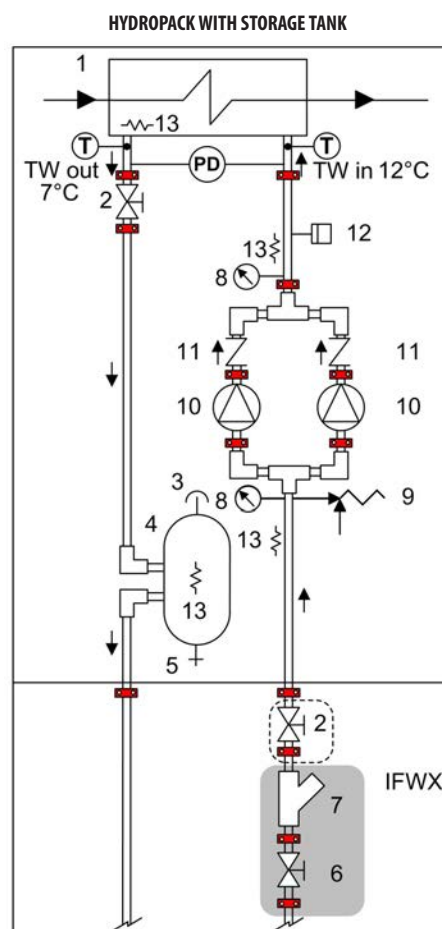
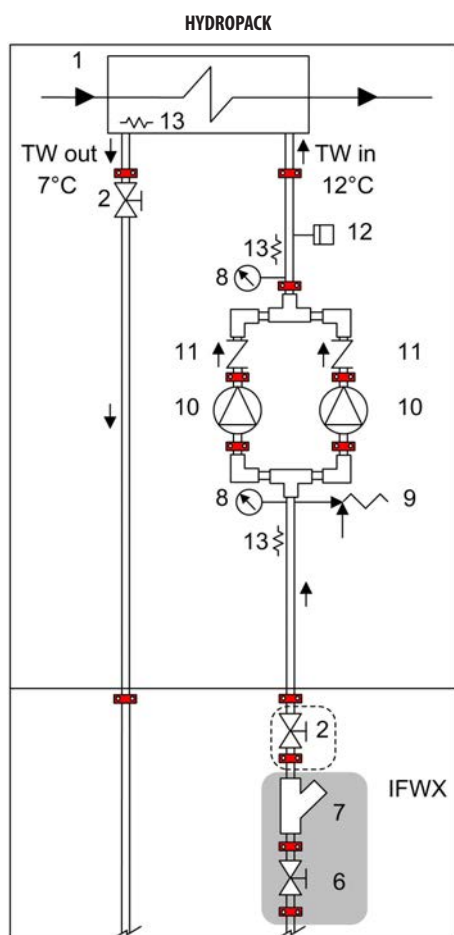

- 1 - Internal exchanger
- 2 - Cutoff valve
- 3 - Purge valve
- 4 - Storage tank with antifreeze heater
- 5 - Draw off cock
- 6 - Cutoff valve with quick joints

- 7 - Steel mesh strainer water side
- 8 - Manometer
- 9 - Safety valve (6 Bar)
- 10 - Packaged electric pump with high efficiency impeller
- 11 - Non return valve
- 12 - System safety pressure switch (prevents the pumps from operating if no water is present)
- 13 - Antifreeze heater

- TW in chilled water inlet
- TW out chilled water outlet
- IFWX = Steel mesh strainer water side

Water connection kit supplied as standard
The grey area indicates further optional components.

2PM option performances (Hydropack)

Version: Excellence

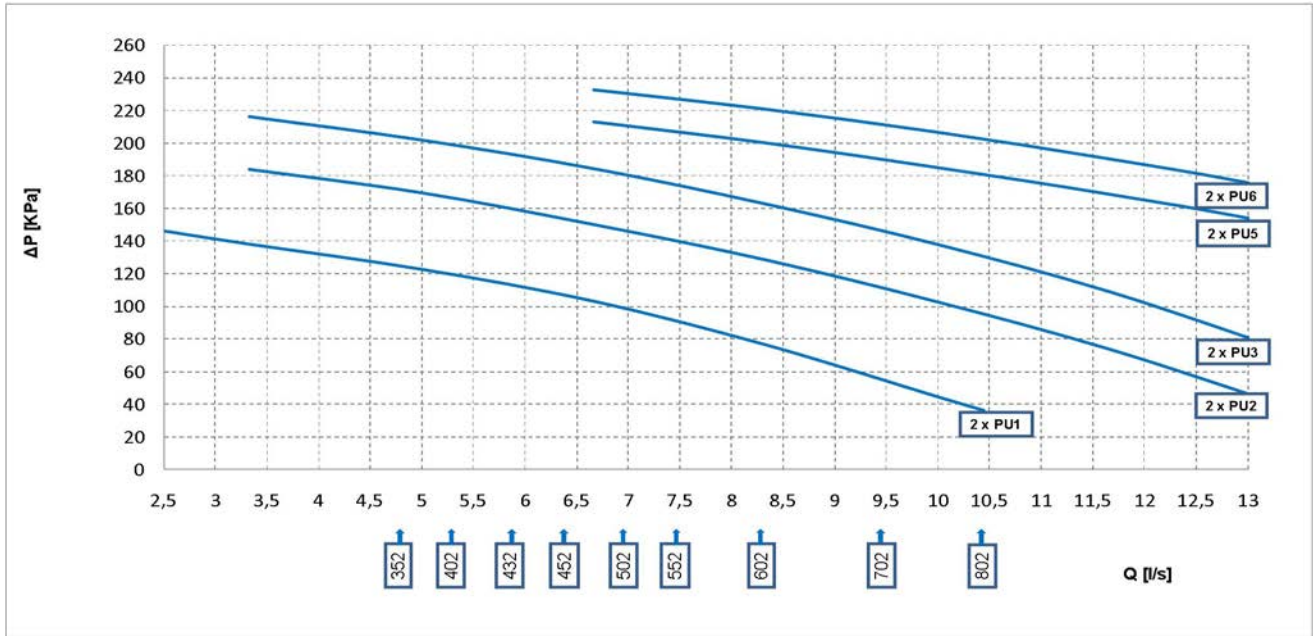

Q = Water-flow rate [l/s]
 ΔP = Head pump [kPa]

Version: Premium

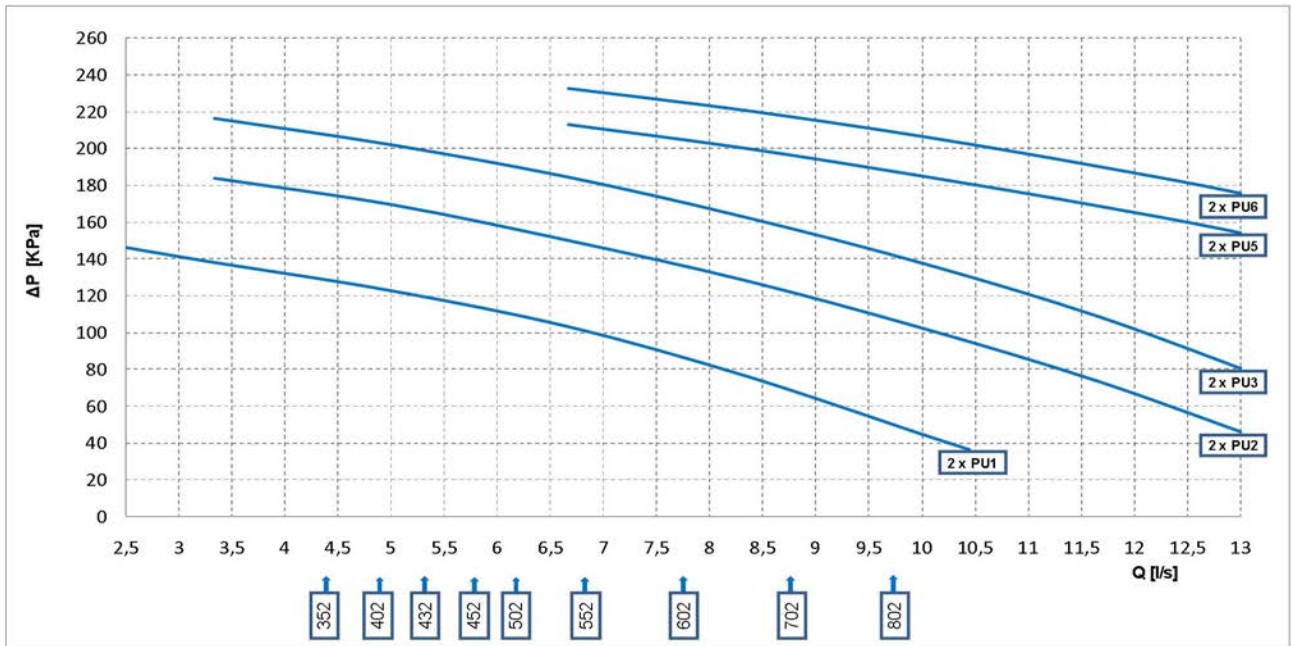

Q = Water-flow rate [l/s]
 ΔP = Head pump [kPa]



Caution: to obtain the available pressure values, you need to subtract the following from the head values represented in these diagrams: -Evaporator pressure drops -IFVX accessory -Steel mesh filter on the water side (where applicable)

Hydropack technical specifications

PUMP	Rated power [kW]	Nominal power [A]
2PU1	2×1.4	2×2.6
2PU2	2×1.4	2×2.6
2PU3	2×1.8	2×3.2
2PU5	2×2.9	2×4.8
2PU6	2×3.3	2×5.6

Accessories

PGFC - Finned coil protection grilles

This accessory is used to protect the external coil from the accidental contact with external things or people.

Ideal for installation in places where persons can pass from, such as car parks, terraces, etc.

The accessory is provided and installed built-in the unit.



This option is not suitable for application in sulphuric environments

PGCCH - Anti-hail protection grilles

These accessories are to protect the external coil from hail damage. Indeed, hail impact can deform the coil fins worsening the heat exchange with the air.

The accessory is provided and installed built-in the unit.

CCCA - Copper / aluminium condensing coil with acrylic lining

Coils with copper pipes and aluminium fins with acrylic lacquering. Can be used in settings with moderately aggressive saline concentrations and other chemical agents.

Attention!

- Cooling capacity variation -2.7%
- Variation in compressor power input +4.2%
- Operating range reduction -2.1°C

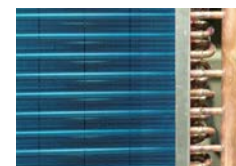

CCCA1 - Copper/aluminum condensing coil with fin guard treatment (silver)

A treatment which offers an optimal thermal exchange and guarantees and protects the finned coil exchangers from corrosion over time. Can be used in settings with very aggressive saline concentrations and other chemical agents in the air thus maintaining the performance of the coils over time.



CCCC - Copper / copper condensing coil

Coils with copper pipes, copper fins and brass structure. Can be used in settings with moderately aggressive saline concentrations and other chemical agents.



This option is not suitable for application in sulphuric environments



Option available on request

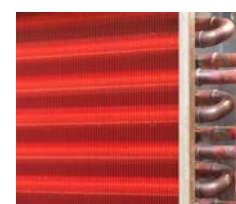

MHP - High and low pressure gauges

Although the standard unit already displays digital parameters of pressures in the refrigeration circuit, this option allows analog display of refrigerant pressures on suction and discharge lines for ease of use by maintenance technicians.

The two liquid pressure gauges and corresponding pressure sockets are installed on the machine in an easily accessible location.

The device is installed built-in the unit.



SDV - Cutoff valve on compressor supply and return

An option which integrates the supply cutoff valve, which is supplied as standard. The presence of the cock at the intake as well enables the compressors to be isolated and substituted without discharging the refrigerant from within the refrigeration circuit. This means that the extraordinary maintenance activities are facilitated.

The device is installed built-in the unit.

1. Compressors
2. Cutoff valve
3. Safety valve
4. SDV option

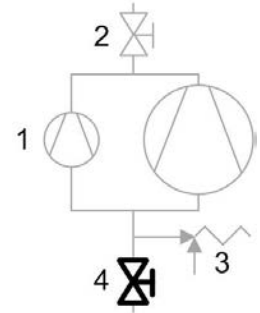

FANQE - Electrical panel ventilation

An option which regards the external helical fans, as an alternative to the ECOBREEZE device which is supplied as standard in the A-class version. It provides for an IP54 three-phase electrical motor with an external rotor and incorporated thermal protection. Supplied with variable speed control.

The device is installed and wired built-in the unit.



RE-20 / RE-25 / RE-30 / RE-35 / RE-39 - Electrical panel anti-freeze protection

This option is necessary for very cold climates, where the external temperature can be between -10°C and -39°C . It includes self-regulating temperature maintaining resistances which are able to protect the electrical panel against condensation and frost guaranteeing that it functions correctly. The choice of device should be carried out on the basis of the minimum temperatures reached at the unit installation site.

The device is installed built-in the unit.



This accessory is necessary for the unit to operate correctly in the FCD (FREE-COOLING) configuration with external temperature at less than -10°C . Furthermore, it is necessary for correct unit maintenance (not operations) in all the remaining configurations.



This accessory operates even when the unit is switched off provided that the power supply is maintained active and the unit continues to be connected.



This accessory does not lead to substantial variations in the electrical data for the unit which has been declared in the Electrical Data section.



MF2 - Multifunction phase monitor

The phase monitor controls the electrical parameters of the power line to the unit. It works on the command circuit and orders the unit to be switched off when one of the following cases is present: when the phase connections do not respect the correct sequence, or when there is over voltage or under voltage for a certain amount of time (limit values of over and under voltage and the time interval can be manually and separately set). When the line conditions are re-established, the unit is re-armed automatically.

The device is installed and wired built-in the unit.



This accessory is available only in the PREMIUM version. Supplied as standard in the EXCELLENCE version



The device prevents sudden changes of voltage; however, the voltage must always be in a range between 380V and 480V.



PFCP - Power-factor capacitors

The component is necessary to lower the phase difference between current and voltage in the electromagnetic components of the unit (e.g. asynchronous motors). The component allows to put the cosφ power factor to values on average higher than 0.9, reducing the network reactive power. This often leads to an economic benefit which the energy provider grants to the final user.

The device is installed built-in the unit.



ECS - ECOSHARE function for the automatic management of a group of units

The device allows automatic management of units that operate on the same hydraulic circuit, by creating a local communication network.

There are two control modes that can be set via a parameter during the activation stage. They both distribute the heat load on the available units by following the distribution logic to benefit from efficiency levels at part load.

Moreover:

Mode 1 - it keeps all the pumps active

Mode 2 - it activates only the pumps of the unit required to operate

The device allows for rotation based on the criterion of minimum wear and management of units in stand-by. There are various unit sizes. Every unit must be fitted with the ECOSHARE feature. The set of units is controlled by a Master unit.

The local network can be extended up to 7 units (1 Master and 6 Slave).



The unit supplied with this device can also be equipped at the same time with the RCMRX option and one of the CMSC8 / CMSC9 / CMSC10 options.

SFSTR – Starting current reduction device

This option is also known as “Soft starter”. An electronic device which automatically starts up the compressors gradually, reducing the starting current for the unit by around 40% in comparison with the nominal value.

This results in the electrical capacity system and the related protection devices being sized with lower parameters, thus having a lower initial investment cost.

The device is installed and wired built-in the unit.

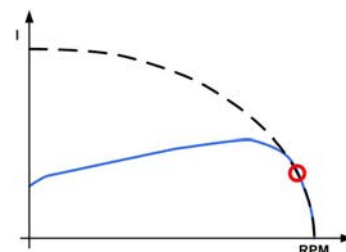

--- Absorbed current without SFSTR option
 — Absorbed current with SFSTR option

ELFOEnergy Large² electrical data (WSAT-XEE SERIES) with SFSTR option

Size		352	402	432	452	502	552	602	702	802
M.I.C. Maximum inrush current										
M.I.C. - Value (EXCELLENCE VERSION)	A	167	179	189	216	222	230	244	298	313
M.I.C. - Value (PREMIUM VERSION)	A	167	179	184	212	217	226	240	294	309

CMSC8 - Serial communication module for BACnet supervisor

Allows the serial connection to supervision systems, by using BACnet as communication protocol. It allows the access to the entire list of operation variables, controls and alarms. With this accessory, every unit can communicate with the main supervision systems.

The device is installed and wired built-in the unit.



The configuration and management activities for the BACnet networks are the responsibility of the client.



The total length of each serial line do not exceed 1000 meters and the line must be connected in bus typology (in/out)



CMSC9 - Serial communication module for MODBUS supervisor

This enables the serial connection of the supervision system, using Modbus as the communication protocol. It enables access to the complete list of operational variables, commands and alarms. Using this accessory every unit can dialogue with the main supervision systems.

The device is installed and wired built-in the unit.



The total length of each serial line do not exceed 1000 meters and the line must be connected in bus typology (in/out)



CMSC10 - Serial communication module for LonWorks supervisor

This enables the serial connection of the supervision system which uses the LonWorks communication protocol. It enables access to a list of operating variables, commands and alarms which comply with the Echelon® standard.

The device is installed and wired built-in the unit.



The configuration and management activities for the BACnet networks are the responsibility of the client.



LonWorks technology uses the LonTalk® protocol for communicating between the network nodes. Contact the service supplier for further information.



The total length of each serial line do not exceed 1000 meters and the line must be connected in bus typology (in/out)



CREFP - External section fan consumption reduction device at variable speed (phase-cutting)

An option which regards the external helical fans, as an alternative to the ECOBREEZE device which is supplied as standard in the EXCELLENCE version. It provides for an IP54 three-phase electrical motor with an external rotor and incorporated thermal protection. Supplied with variable speed control.

The device is installed and wired built-in the unit.

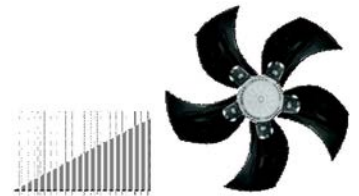

CONTA2 - Energy meter

Allows to display and record the unit's main electrical parameters. The data can be displayed with the user interface on the unit or via the supervisor through the specific protocol variables.

It is possible to control:

- voltage (V),
- absorbed current (A),
- frequency (Hz),
- $\cos\phi$,
- power input (KW),
- absorbed energy (KWh),
- harmonic components (%).

The device is installed and wired built-in the unit.



Only the following parameters are available on the LonWorks protocol: absorbed power (kW) and absorbed energy (kWh)

SPC4 - Set-point compensation with 0-10 V signal

This device enables the set-point to be varied which is pre-set using an external 0÷10 V signal.

The device is installed and wired built-in the unit.

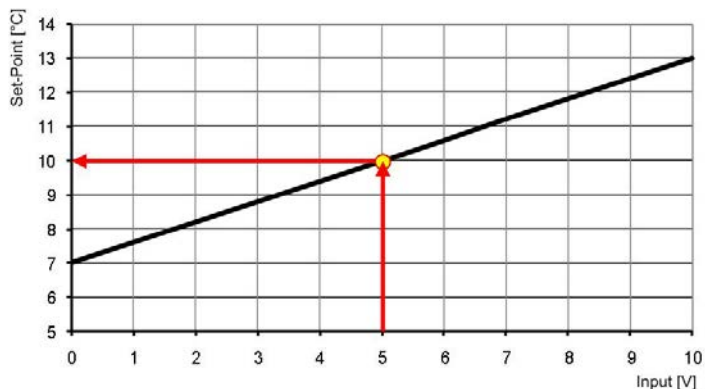

SPC2 - set point compensation with outdoor air probe

This device enables the set-point to be varied automatically which is pre-set depending on the enthalpy of the outdoor air. This device enables the liquid flow temperature to be obtained, which varies depending on external conditions, enabling energy savings throughout the entire system.

The device is installed and wired built-in the unit.

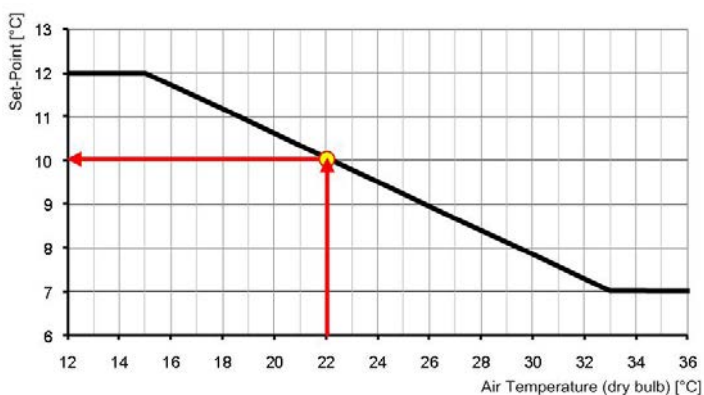

Accessories separately supplied

RCMRX - Remote control via microprocessor remote control

This option allows to have full control over all the unit functions from a remote position.

It can be easily installed on the wall and has the same aspect and functions of the user interface on the unit.

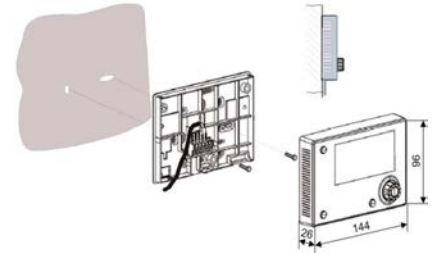

All device functions can be repeated with a normal portable PC connected to the unit with an Ethernet cable and equipped with an internet navigation browser.



The device must be installed on the wall with suitable plugs and connected to the unit (installation and wiring to be conducted by the Customer). Maximum remote control distance 350 m without auxiliary power supply. For distances greater than 350 m and in any case less than 700 m it is necessary to install the 'PSX - Mains power unit' accessory.



Data and power supply serial connection cable n.1 twisted and shielded pair. Diameter of the individual conductor 0.8 mm.

PSX - Mains power supply unit

The device allows the unit and the remote control to communicate with the user interface even when the serial line is longer than 350m.

It must be connected to the serial line at a distance of 350m from the unit and allows to extend the length to 700m maximum in total. The device requires an external power supply at 230V AC.



Power supply at 230V AC provided by Customer



AMMX - Spring antivibration mounts

The spring antivibration mounts are attached in special housing on the support frame and serve to smooth the vibrations produced by the unit thus reducing the noise transmitted to the support structure.



Correction factors for glycol use

% ethylene glycol by weight		5%	10%	15%	20%	25%	30%	35%	40%
Freezing temperature	°C	-2,0	-3,9	-6,5	-8,9	-11,8	-15,6	-19,0	-23,4
Safety temperature	°C	3,0	1,0	-1,0	-4,0	-6,0	-10,0	-14,0	-19,0
Cooling Capacity Factor	No	0,995	0,99	0,985	0,981	0,977	0,974	0,971	0,968
Compressor input Factor	No	0,997	0,993	0,99	0,988	0,986	0,984	0,982	0,981
Internal exchanger Glycol solution flow Factor	No	1,003	1,01	1,02	1,033	1,05	1,072	1,095	1,124
Pressure drop Factor	No	1,029	1,06	1,09	1,118	1,149	1,182	1,211	1,243

The correction factors shown refer to water and glycol ethylene mixes used to prevent the formation of frost on the exchangers in the water circuit during inactivity in winter.

Fouling Correction Factors

m2 K / W	Internal exchanger	
	F1	FK1
0.44 x 10 (-4)	1,0	1,0
0.88 x 10 (-4)	0,97	0,99
1.76 x 10 (-4)	0,94	0,98

F1 = Cooling capacity correction factors

FK1 = Compressor power input correction factor

Overload and control device calibrations

			open	closed	value
high pressure safety pressure switch		[kPa]	4050	3300	-
low pressure safety switch		[kPa]	450	600	-
low pressure switch (Brine)		[kPa]	200	350	-
antifreeze protection		[°C]	3	5.5	-
high pressure safety valve		[kPa]	-	-	4500
low pressure safety valve		[kPa]	-	-	3000
Max no. of compressor starts per hour		[n°]	-	-	10
high compressor discharge temperature safety thermostat		[°C]	-	-	120

Plate exchanger operating range

	Internal exchanger	
	DPr	DPw
	[kPa]	[kPa]
CLIVET C	4500	1000
PED (CE)	4500	1000

DPr = Max. operating pressure refrigerant gas side

DPw = Max. operating pressure water side (utility)

Option compatibility of Excellence version

REF.	Description	352	402	432	452	502	552	602	702	802
Configurations and main accessories										
B	Water low temperature	0	0	0	0	0	0	0	0	0
D	Partial energy recovery	0	0	0	0	0	0	0	0	0
R	Total energy recovery	0	0	0	0	0	0	0	0	0
FCD	direct FREE-COOLING	0	0	0	0	0	0	0	0	0
B + D	Low water temperature + Partial energy recovery	0	0	0	0	0	0	0	0	0
B + R	Low water temperature + Total energy recovery	0	0	0	0	0	0	0	0	0
B + FCD	Low water temperature + direct FREE-COOLING	X	X	X	X	X	X	X	X	X
D + FCD	Partial energy recovery + direct FREE-COOLING	0	0	0	0	0	0	0	0	0
R + FCD	Total energy recovery + direct FREE-COOLING	X	X	X	X	X	X	X	X	X
A300	300-litre storage tank	0	0	0	0	0	0	0	X	X
A500	500-litre storage tank	X	X	X	X	X	X	X	0	0
1PUS - Standard pump										
(PU1)	Type 1 pump	0	0	0	X	X	X	X	X	X
(PU2) / (PU3)	Pump type 2/Pump type 3	0	0	0	0	0	X	X	X	X
(PU4) / (PU5) / (PU6)	Pump type 4 / Pump type 5/Pump type 6	0	0	0	0	0	0	0	0	0
+ D	+ Partial energy recovery	0	0	0	0	0	0	0	0	0
+ D + A300	+ Partial energy recovery + 300 litres storage tank	0	0	0	0	0	0	0	X	X
+ D + A500	+ Partial energy recovery + 500 litres storage tank	X	X	X	X	X	X	X	0	0
+ A300RPS (PU1)	+ 300-litre storage tank with primary circuit built-in	0	0	0	X	X	X	X	X	X
+ A300RPS (PU4)	+ 300-litre storage tank with primary circuit built-in	X	X	X	0	0	0	0	X	X
+ A500RPS (PU4)	+ 500 litres storage tank with primary circuit built-in	X	X	X	X	X	X	X	0	0
1PU1SB - Standard pump with standby pump										
(PU1)	Type 1 pump	0	0	0	X	X	X	X	X	X
(PU2) / (PU3)	Pump type 2/Pump type 3	0	0	0	0	0	X	X	X	X
(PU4) / (PU5) / (PU6)	Pump type 4 / Pump type 5/Pump type 6	0	0	0	0	0	0	0	0	0
+ D	+ Partial energy recovery	0	0	0	0	0	0	0	0	0
+ D + A300	+ Partial energy recovery + 300 litres storage tank	0	0	0	0	0	0	0	X	X
+ D + A500	+ Partial energy recovery + 500 litres storage tank	X	X	X	X	X	X	X	0	0
+ A300RPS (PU1)	+ 300-litre storage tank with primary circuit built-in	0	0	0	X	X	X	X	X	X
+ A300RPS (PU4)	+ 300-litre storage tank with primary circuit built-in	X	X	X	0	0	0	0	X	X
+ A500RPS (PU4)	+ 500 litres storage tank with primary circuit built-in	X	X	X	X	X	X	X	0	0
2PM - Hydropack with 2 pumps										
(PU1)	Type 1 pump	0	0	0	0	0	0	0	0	X
(PU2) / (PU3)	Pump type 2/Pump type 3	0	0	0	0	0	0	0	0	0
(PU4)	Type 4 pump	X	X	X	X	X	X	X	X	X
(PU5) / (PU6)	Pump type 5 / Pump type 6	X	X	X	X	X	X	0	0	0
+ A300RPS	+ 300-litre storage tank with primary circuit built-in	X	X	X	X	X	X	X	X	X
+ A500RPS	+ 500 litres storage tank with primary circuit built-in	X	X	X	X	X	X	X	X	X
Other accessories										
CREFB	Device to reduce the consumption levels of Eco Breeze fans on the external section	•	•	•	•	•	•	•	•	•
CREFP	Device for consumption reduction of the external section at variable speed (phase-cutting)	0	0	0	0	0	0	0	0	0
FCD + CCCA	Direct FREE-COOLING + Copper / aluminium condensing coil with acrylic lining	0	0	0	0	0	0	0	0	0
FCD + CCCA1	Direct FREE-COOLING + Copper / aluminium condensing coil with Fin Guard treatment (Silver)	X	X	X	X	X	X	X	X	X
FCD + CCCC	Direct FREE-COOLING + Copper / copper condensing coil	X	X	X	X	X	X	X	X	X

• Standard

◦ Option

× Not available

Option compatibility of Premium version

REF.	DESCRIPTION	352	402	432	452	502	552	602	702	802
Configurations and main accessories										
B	Water low temperature	0	0	0	0	0	0	0	0	0
D	Partial energy recovery	0	0	0	0	0	0	0	0	0
R	Total energy recovery	0	0	0	0	0	0	0	0	0
FCD	direct FREE-COOLING	X	X	X	X	X	X	X	X	X
B + D	Low water temperature + Partial energy recovery	0	0	0	0	0	0	0	0	0
B + R	Low water temperature + Total energy recovery	0	0	0	0	0	0	0	0	0
B + FCD	Low water temperature + direct FREE-COOLING	X	X	X	X	X	X	X	X	X
D + FCD	Partial energy recovery + direct FREE-COOLING	X	X	X	X	X	X	X	X	X
R + FCD	Total energy recovery + direct FREE-COOLING	X	X	X	X	X	X	X	X	X
A300	300-litre storage tank	0	0	0	0	0	0	0	X	X
A500	500-litre storage tank	X	X	X	X	X	X	X	0	0
1PUS - Standard pump										
(PU1)	Type 1 pump	0	0	0	X	X	X	X	X	X
(PU2) / (PU3)	Pump type 2 / Pump type 3	0	0	0	0	0	X	X	X	X
(PU4) / (PU5) / (PU6)	Pump type 4 / Pump type 5 / Pump type 6	0	0	0	0	0	0	0	0	0
+ D	+ Partial energy recovery	0	0	0	0	0	0	0	0	0
+ D + A300	+ Partial energy recovery + 300 litres storage tank	0	0	0	0	0	0	0	X	X
+ D + A500	+ Partial energy recovery + 500 litres storage tank	X	X	X	X	X	X	X	0	0
+ A300RPS (PU1)	+ 300-litre storage tank with primary circuit built-in	0	0	0	X	X	X	X	X	X
+ A300RPS (PU4)	+ 300-litre storage tank with primary circuit built-in	X	X	X	0	0	0	0	X	X
+ A500RPS (PU4)	+ 500 litres storage tank with primary circuit built-in	X	X	X	X	X	X	X	0	0
1PU1SB - Standard pump with standby pump										
(PU1)	Type 1 pump	0	0	0	X	X	X	X	X	X
(PU2) / (PU3)	Pump type 2 / Pump type 3	0	0	0	0	0	X	X	X	X
(PU4) / (PU5) / (PU6)	Pump type 4 / Pump type 5 / Pump type 6	0	0	0	0	0	0	0	0	0
+ D	+ Partial energy recovery	0	0	0	0	0	0	0	0	0
+ D + A300	+ Partial energy recovery + 300 litres storage tank	0	0	0	0	0	0	0	X	X
+ D + A500	+ Partial energy recovery + 500 litres storage tank	X	X	X	X	X	X	X	0	0
+ A300RPS (PU1)	+ 300-litre storage tank with primary circuit built-in	0	0	0	X	X	X	X	X	X
+ A300RPS (PU4)	+ 300-litre storage tank with primary circuit built-in	X	X	X	0	0	0	0	X	X
+ A500RPS (PU4)	+ 500 litres storage tank with primary circuit built-in	X	X	X	X	X	X	X	0	0
2PM - Hydropack with 2 pumps										
(PU1)	Type 1 pump	0	0	0	0	0	0	0	0	X
(PU2) / (PU3)	Pump type 2 / Pump type 3	0	0	0	0	0	0	0	0	0
(PU4)	Type 4 pump	X	X	X	X	X	X	X	X	X
(PU5) / (PU6)	Pump type 5 / Pump type 6	X	X	X	X	X	X	0	0	0
+ A300RPS	+ 300-litre storage tank with primary circuit built-in	X	X	X	X	X	X	X	X	X
+ A500RPS	+ 500 litres storage tank with primary circuit built-in	X	X	X	X	X	X	X	X	X
Other accessories										
CREFB	Device to reduce the consumption levels of Eco Breeze fans on the external section	X	X	X	X	X	X	X	X	X
CREFP	Device for consumption reduction of the external section at variable speed (phase-cutting)

- Standard
- Option
- × Not available

Dimensional drawings: Excellence version

WSAT-XEE 352-402-432

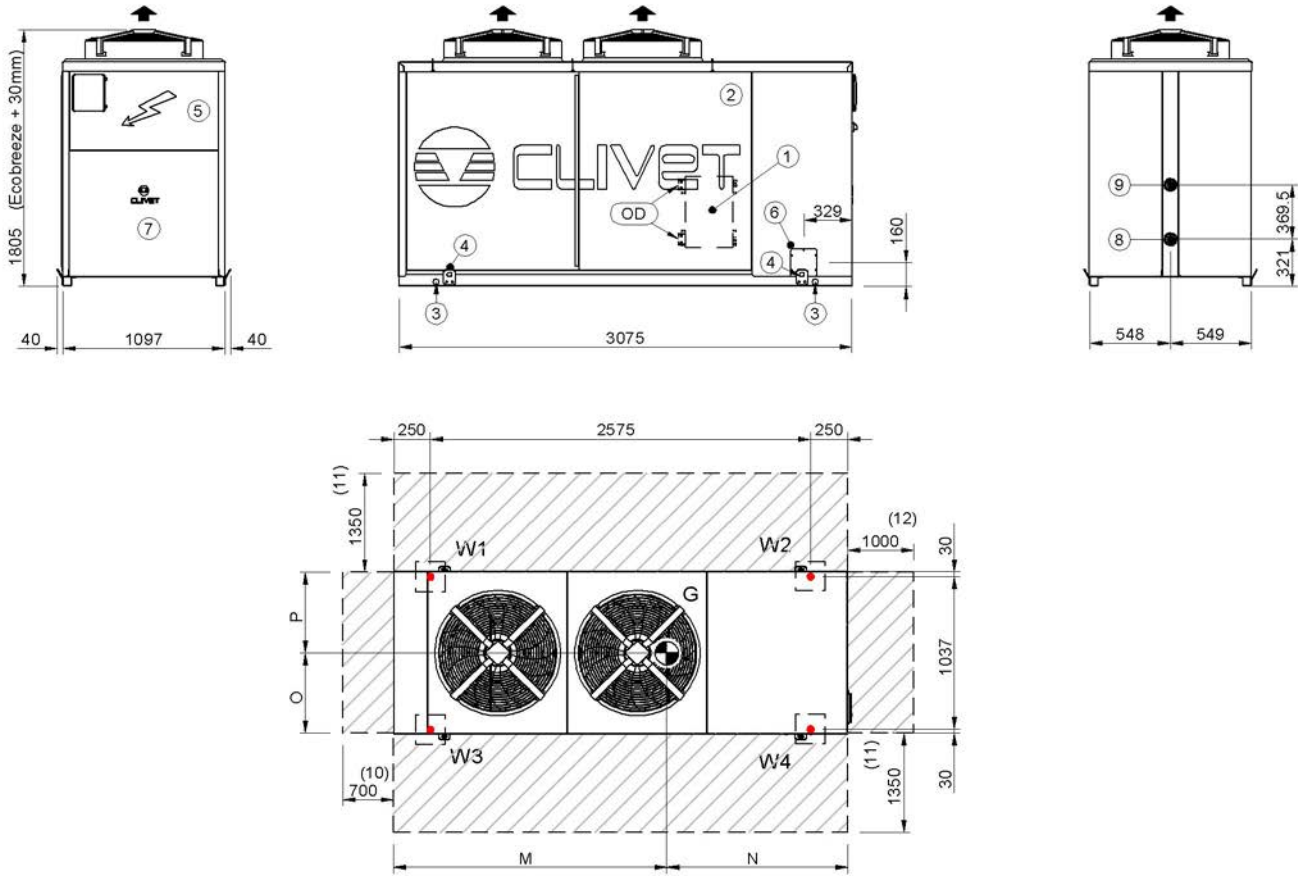

- 1. Internal exchanger (evaporator)
- 2. External exchanger (condenser)
- 3. Unit fixing holes
- 4. Lifting brackets (removable, if required, after the unit positioning)
- 5. Electrical panel
- 6. Power input
- 7. Soundproofed cabin
- 8. Internal exchanger water outlet. The heights of the connections may change if there are optional components: pump, storage tank, free-cooling, partial or total recovery.
- 9. Internal exchanger water inlet. The heights of the connections may change if there are optional components: pump, storage tank, free-cooling, partial or total recovery.
- 10. Minimum Safe Clearance
- 11. Minimum Clearance for a Proper Air flow to the Condenser
- 12. Minimum Clearance Electrical Panel Side
- (G) Centre of gravity

		SC-EXC			EN-EXC		
Size		352	402	432	352	402	432
M	mm	1933	1946	2011	1933	1946	2011
N	mm	1142	1129	1064	1142	1129	1064
O	mm	579	581	590	579	581	590
P	mm	518	516	507	518	516	507
OD	mm	76	76	76	76	76	76
Length	mm	3075	3075	3075	3075	3075	3075
Depth	mm	1097	1097	1097	1097	1097	1097
Height	mm	1805	1805	1805	1805	1805	1805
W1 Supporting Point	kg	149	153	156	149	153	156
W2 Supporting Point	kg	325	342	396	325	342	396
W3 Supporting Point	kg	161	165	168	161	165	168
W4 Supporting Point	kg	261	272	304	261	272	304
Shipping weight	kg	889	925	1015	889	925	1015
Operating weight	kg	896	933	1024	896	933	1024

The presence of optional accessories may result in a substantial variation of the weights shown in the table.

WSAT-XEE 452-502-552-602

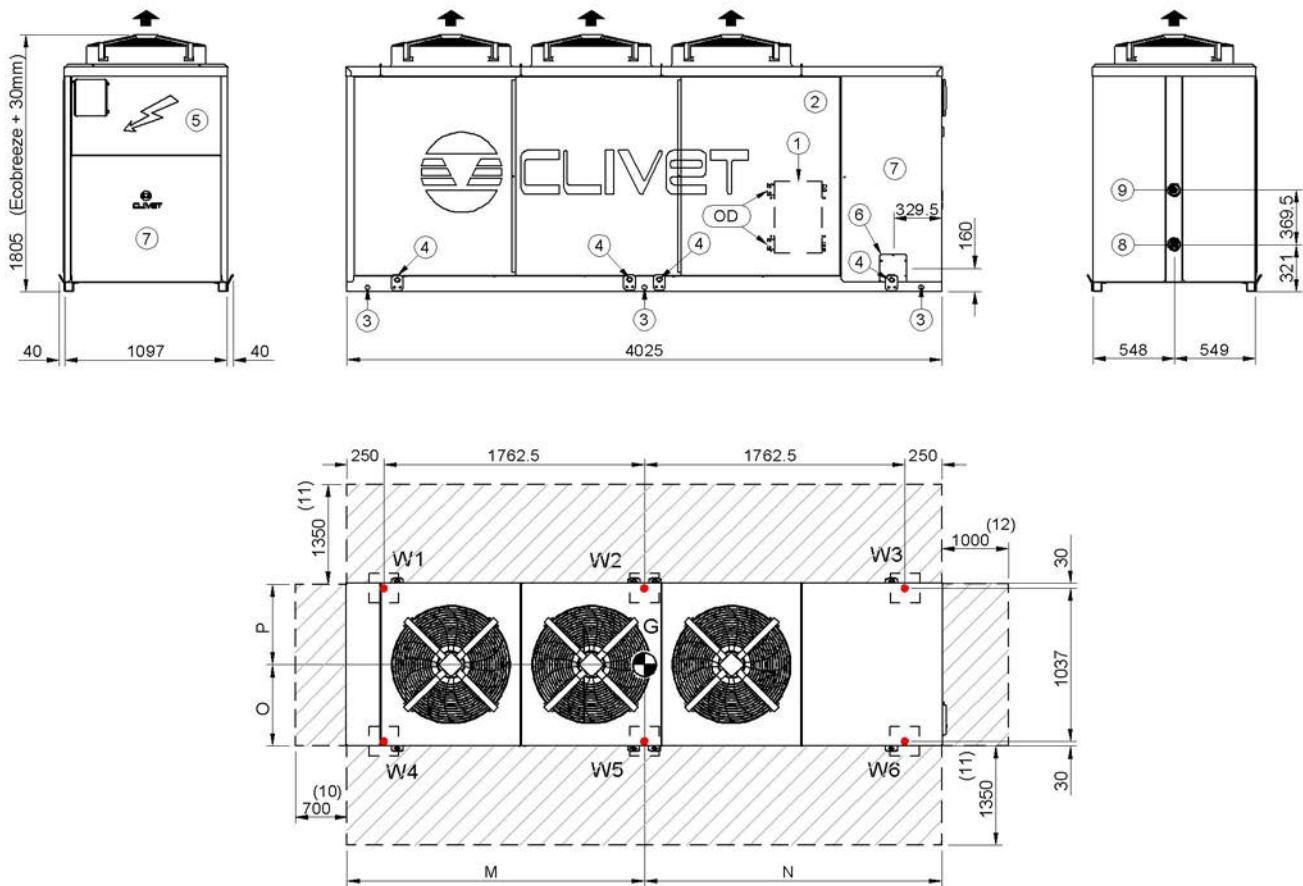

1. Internal exchanger (evaporator)
2. External exchanger (condenser)
3. Unit fixing holes
4. Lifting brackets (removable, if required, after positioning the unit)
5. Electrical panel
6. Power input
7. Soundproofed cabin
8. Internal exchanger water outlet. The heights of the connections may change if there are optional components: pump, storage tank, free-cooling, partial or total recovery.
9. Internal exchanger water inlet. The heights of the connections may change if there are optional components: pump, storage tank, free-cooling, partial or total recovery.
10. Minimum Safe Clearance
11. Minimum Clearance for a Proper Air flow to the Condenser
12. Minimum Clearance Electrical Panel Side
- (G) Centre of gravity

Size		SC-EXC				EN-EXC			
		452	502	552	602	452	502	552	602
M	mm	2553	2576	2574	2590	2553	2576	2574	2590
N	mm	1472	1449	1451	1435	1472	1449	1451	1435
O	mm	564	565	565	566	564	565	565	566
P	mm	533	532	532	531	533	532	532	531
OD	mm	76	76	76	76	76	76	76	76
Length	mm	4025	4025	4025	4025	4025	4025	4025	4025
Depth	mm	1097	1097	1097	1097	1097	1097	1097	1097
Height	mm	1805	1805	1805	1805	1805	1805	1805	1805
W1 Supporting Point	kg	80	80	82	84	80	80	82	84
W2 Supporting Point	kg	254	257	261	267	254	257	261	267
W3 Supporting Point	kg	287	301	306	323	287	301	306	323
W4 Supporting Point	kg	85	85	87	89	85	85	87	89
W5 Supporting Point	kg	253	255	259	265	253	255	259	265
W6 Supporting Point	kg	247	258	262	275	247	258	262	275
Shipping weight	kg	1198	1224	1246	1290	1198	1224	1246	1290
Operating weight	kg	1207	1234	1256	1302	1207	1234	1256	1302

The presence of optional accessories may result in a substantial variation of the weights shown in the table.

WSAT-XEE 702-802

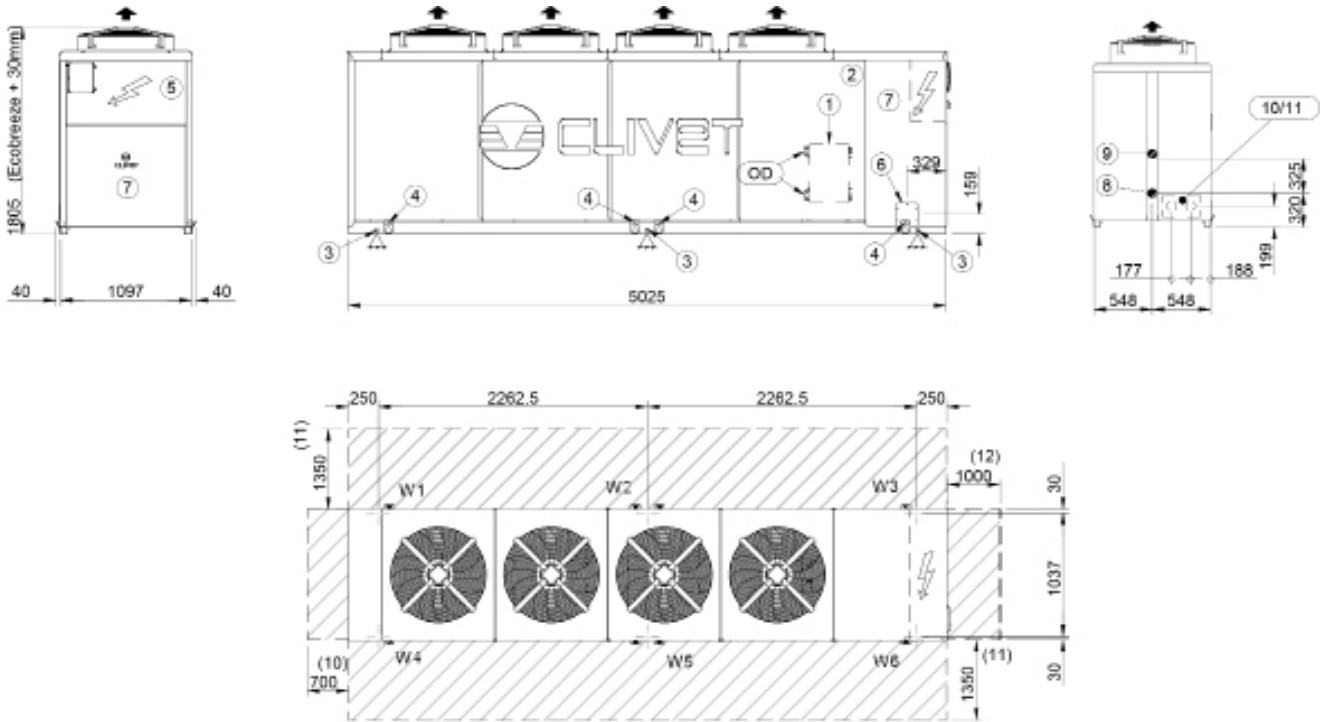

1. Internal exchanger (evaporator)
2. External exchanger (condenser)
3. Unit fixing holes
4. Lifting brackets (removable, if required, after positioning the unit)
5. Electrical panel
6. Power input
7. Soundproofed cabin
8. Internal exchanger water outlet. The heights of the connections may change if there are optional components: pump, storage tank, free-cooling, partial or total recovery.
9. Internal exchanger water inlet. The heights of the connections may change if there are optional components: pump, storage tank, free-cooling, partial or total recovery.
10. Total recovery water inlet connections (OD=1"1/4 or 2" Victaulic type) Optional
11. Partial recovery water outlet connections (OD=1"1/4 or 2" Victaulic type) Optional
- (G) Centre of gravity

		SC-EXC		EN-EXC	
Size		702	802	702	802
M	mm	3216	3227	3216	3227
N	mm	1809	1798	1809	1798
O	mm	564	565	564	565
P	mm	533	532	533	532
OD	mm	76	76	76	76
Length	mm	5025	5025	5025	5025
Depth	mm	1097	1097	1097	1097
Height	mm	1805	1805	1805	1805
W1 Supporting Point	kg	114	115	114	115
W2 Supporting Point	kg	284	292	284	292
W3 Supporting Point	kg	374	389	374	389
W4 Supporting Point	kg	108	109	108	109
W5 Supporting Point	kg	306	315	306	315
W6 Supporting Point	kg	312	323	312	323
Shipping weight	kg	1483	1527	1483	1527
Operating weight	kg	1497	1544	1497	1544

The presence of optional accessories may result in a substantial variation of the weights shown in the table.

Dimensional drawings: Premium version

WSAT-XEE 352-402-432-452-502-552

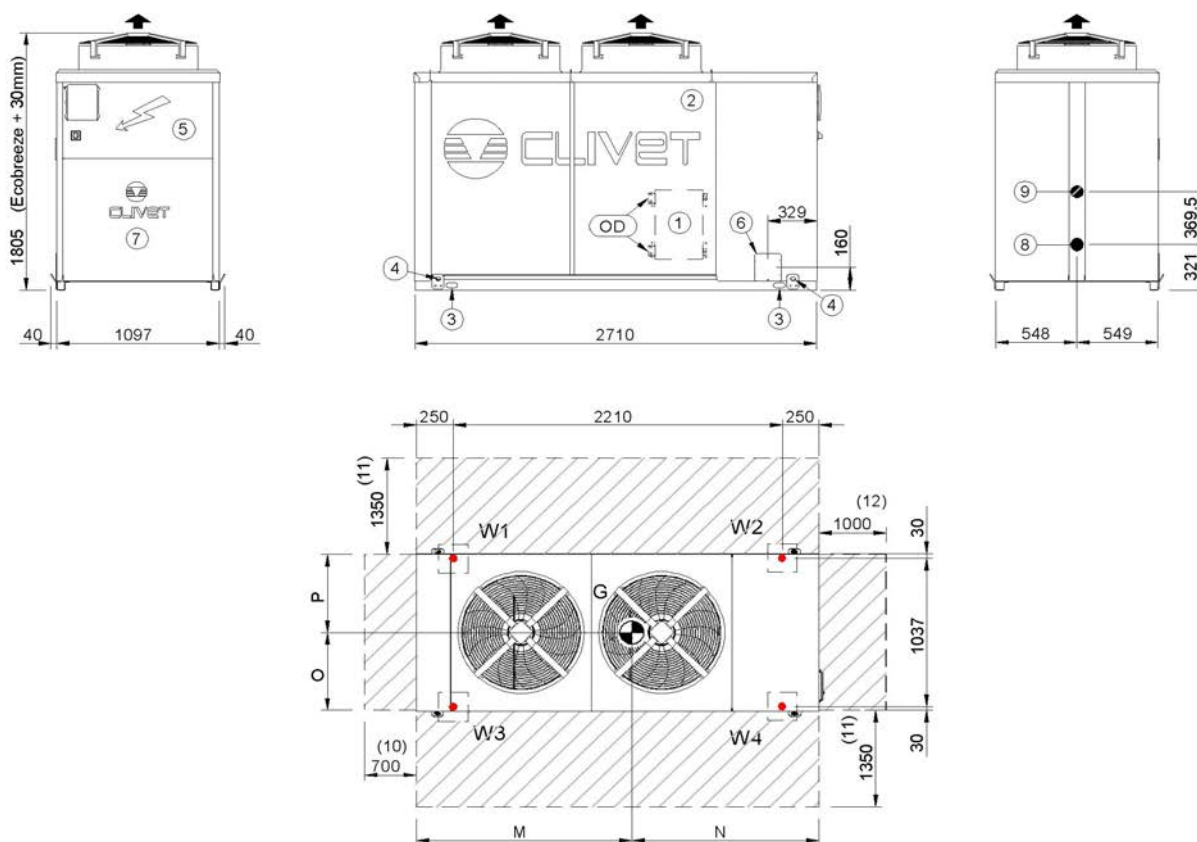

1. Internal exchanger (evaporator)
2. External exchanger (condenser)
3. Unit fixing holes
4. Lifting brackets (removable, if required, after positioning the unit)
5. Electrical panel
6. Power input
7. Soundproofed cabin
8. Internal exchanger water outlet. The heights of the connections may change if there are optional components: pump, storage tank, free-cooling, partial or total recovery.
9. Internal exchanger water inlet. The heights of the connections may change if there are optional components: pump, storage tank, free-cooling, partial or total recovery.
10. Minimum Safe Clearance
11. Minimum Clearance for a Proper Air flow to the Condenser
12. Minimum Clearance Electrical Panel Side
- (G) Centre of gravity

		SC-PRM						EN-PRM					
Size		352	402	432	452	502	552	352	402	432	452	502	552
M	mm	1637	1658	1724	1699	1704	1714	1637	1658	1724	1699	1704	1714
N	mm	1073	1052	986	1011	1006	996	1073	1052	986	1011	1006	996
O	mm	584	587	596	594	596	596	584	587	596	594	596	596
P	mm	513	510	501	503	501	501	513	510	501	503	501	501
OD	mm	76	76	76	76	76	76	76	76	76	76	76	76
Length	mm	2710	2710	2710	2710	2710	2710	2710	2710	2710	2710	2710	2710
Depth	mm	1097	1097	1097	1097	1097	1097	1097	1097	1097	1097	1097	1097
Height	mm	1805	1805	1805	1805	1805	1805	1805	1805	1805	1805	1805	1805
W1 Supporting Point	kg	138	138	141	152	158	159	138	138	141	152	158	159
W2 Supporting Point	kg	277	291	344	350	367	377	277	291	344	350	367	377
W3 Supporting Point	kg	152	153	155	166	172	173	152	153	155	166	172	173
W4 Supporting Point	kg	211	219	250	256	267	274	211	219	250	256	267	274
Shipping weight	kg	773	796	885	917	955	975	773	796	885	917	955	975
Operating weight	kg	778	802	892	924	963	984	778	802	892	924	963	984

The presence of optional accessories may result in a substantial variation of the weights shown in the table.

WSAT-XEE 602

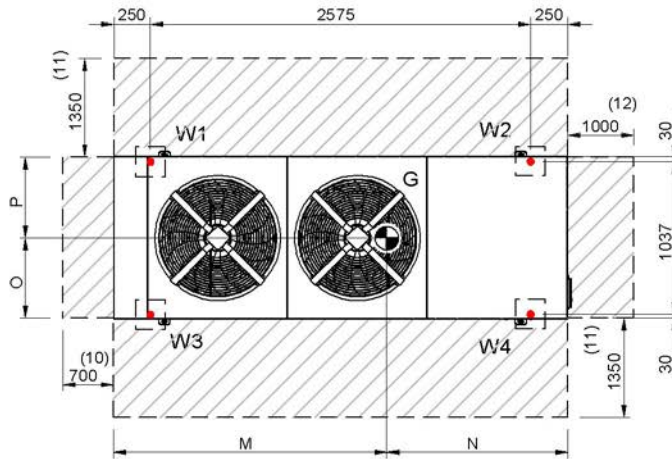
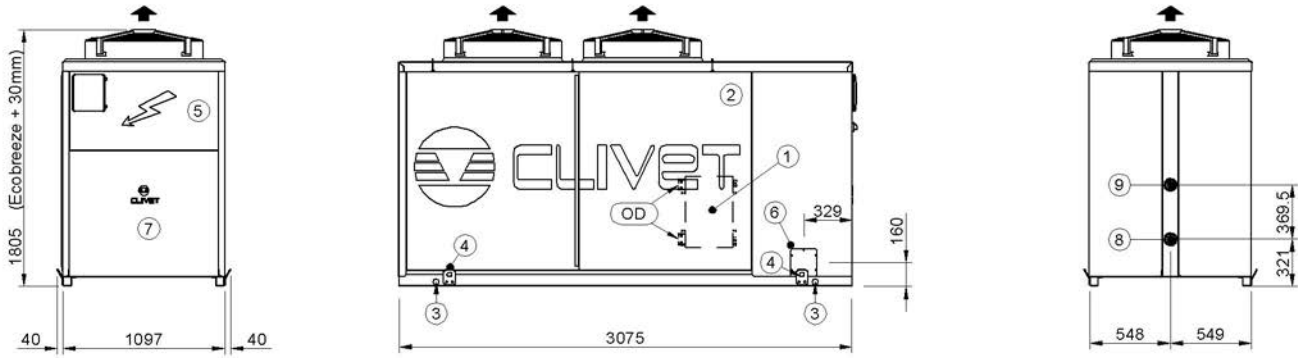

- 1. Internal exchanger (evaporator)
- 2. External exchanger (condenser)
- 3. Unit fixing holes
- 4. Lifting brackets (removable, if required, after positioning the unit)
- 5. Electrical panel
- 6. Power input
- 7. Soundproofed cabin
- 8. Internal exchanger water outlet. The heights of the connections may change if
- 9. Internal exchanger water inlet. The heights of the connections may change if there are optional components: pump, storage tank, free-cooling, partial or total recovery.
- 10. Minimum Safe Clearance
- 11. Minimum Clearance for a Proper Air flow to the Condenser
- 12. Minimum Clearance Electrical Panel Side
- (G) Centre of gravity

		SC-PRM	EN-PRM
Size		602	602
M	mm	2052	2052
N	mm	1023	1023
O	mm	595	595
P	mm	502	502
OD	mm	76	76
Length	mm	3075	3075
Depth	mm	1097	1097
Height	mm	1805	1805
W1 Supporting Point	kg	157	157
W2 Supporting Point	kg	434	434
W3 Supporting Point	kg	169	169
W4 Supporting Point	kg	326	326
W5 Supporting Point	kg	0.0	0.0
W6 Supporting Point	kg	0.0	0.0
Shipping weight	kg	1077	1077
Operating weight	kg	1087	1087

The presence of optional accessories may result in a substantial variation of the weights shown in the table.

WSAT-XEE 702-802

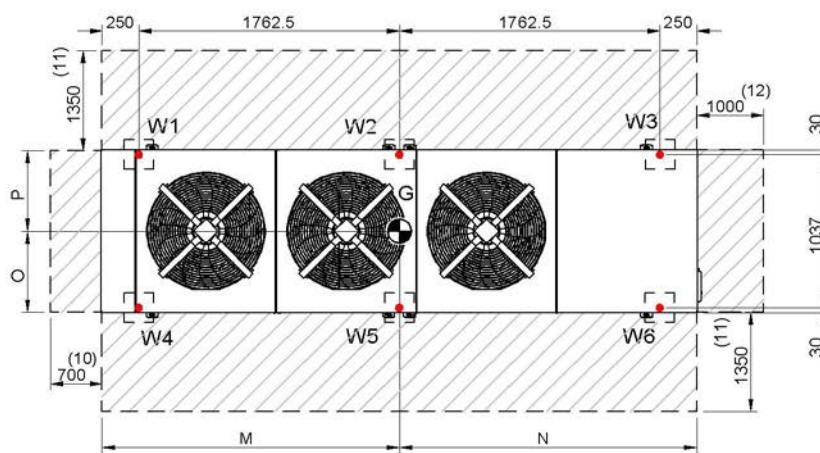
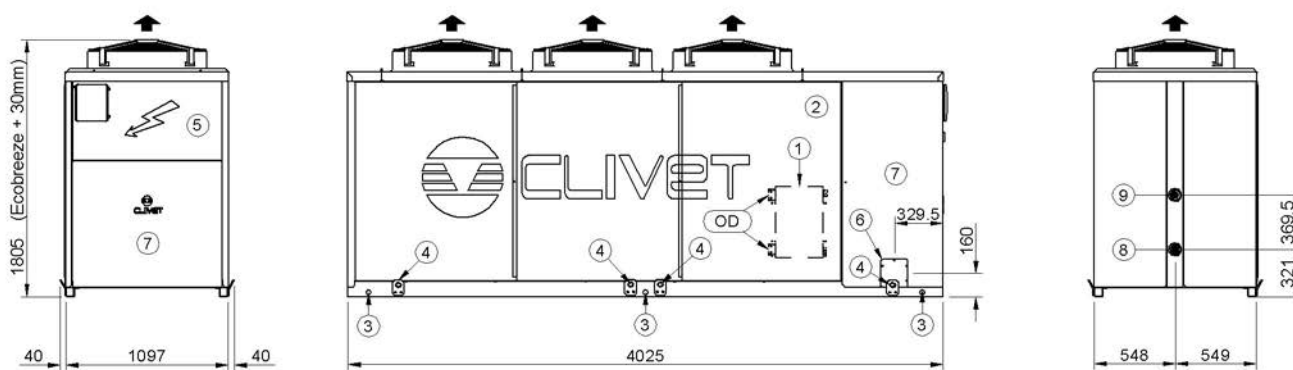

1. Internal exchanger (evaporator)
2. External exchanger (condenser)
3. Unit fixing holes
4. Lifting brackets (removable, if required, after positioning the unit)
5. Electrical panel
6. Power input
7. Soundproofed cabin
8. Internal exchanger water outlet. The heights of the connections may change if
9. Internal exchanger water inlet. The heights of the connections may change if there are optional components: pump, storage tank, free-cooling, partial or total recovery.
10. Minimum Safe Clearance
11. Minimum Clearance for a Proper Air flow to the Condenser
12. Minimum Clearance Electrical Panel Side
- (G) Centre of gravity

Size		SC-PRM		EN-PRM	
		702	802	702	802
M	mm	2626	2643	2626	2643
N	mm	1399	1382	1399	1382
O	mm	567	567	567	567
P	mm	530	530	530	530
OD	mm	76	76	76	76
Length	mm	4025	4025	4025	4025
Depth	mm	1097	1097	1097	1097
Height	mm	1805	1805	1805	1805
W1 Supporting Point	kg	79	79	79	79
W2 Supporting Point	kg	260	264	260	264
W3 Supporting Point	kg	332	344	332	344
W4 Supporting Point	kg	84	84	84	84
W5 Supporting Point	kg	258	262	258	262
W6 Supporting Point	kg	282	292	282	292
Shipping weight	kg	1283	1310	1283	1310
Operating weight	kg	1295	1324	1295	1324

The presence of optional accessories may result in a substantial variation of the weights shown in the table.

Page intentionally left blank

Page intentionally left blank

FOR OVER 30 YEARS WE HAVE BEEN
OFFERING SOLUTIONS TO ENSURE
SUSTAINABLE COMFORT AND THE WELL-
BEING OF PEOPLE AND THE ENVIRONMENT

www.clivet.com

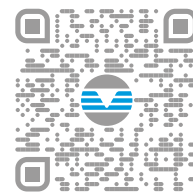

sale and assistance



CLIVET SPA
Via Camp Lonc 25, Z.I. Villapaiera
32032 Feltre (BL) - Italy
Tel. +39 0439 3131 - Fax +39 0439 313300
info@clivet.it

ELFOEnergy Large² - WSAT-XEE 352-802 - BT12N001GB-07

MideaGroup
humanizing technology