



HIGH STATIC PRESSURE DUCT

CN-2-XMi series D71÷D560

MANUAL
FOR INSTALLATION,
USE AND MAINTENANCE



MONB00002-01 - 01/2021

INTRODUCTION

Dear Customer,

Thank you for choosing a **CLIVET** product.

The model which you have chosen is a high performance product of advanced design and technology, high reliability and quality construction.

We suggest that you entrust its management and maintenance to professionally qualified personnel you trust, who, when necessary, only use original spare parts.

This manual contains important information and tips that must be followed for easier installation and the best possible use of the appliance.

SERIES

VRF systems	
HIGH STATIC PRESSURE DUCT unit	from D71 to D560

SYMBOLS USED IN THE MANUAL AND THEIR MEANING



WARNING

To indicate special information.



CAUTION

To indicate particularly important and delicate operations.



CAUTION DANGER

To indicate actions which, if not carried out correctly, may result in general accidents or may cause malfunctions or material damage to the appliance; therefore, they require special attention and adequate preparation.



ATTENTION ELECTRIC DANGER

To indicate actions which, if not carried out correctly, may result in accidents of electrical origin; therefore, they require special attention and adequate preparation.



IT IS PROHIBITED TO

indicate actions that **MUST NOT** be performed.

WARRANTY

The product **CLIVET** is covered by a **conventional warranty**, valid from the date of purchase of the appliance, the conditions of which are specified in the GENERAL CONDITIONS OF SALE available at www.clivet.com



WARNING

- The warranty is void if the appliance has been used without following the instructions in this manual.
- The warranty will be forfeited if the customer makes changes and/or attempts to repair the product himself or through third parties not authorised by the manufacturer/authorised dealer.
- The product must be intended for the use intended by **CLIVET** for which it was expressly made. Any contractual and non-contractual liability **CLIVET** for damage caused to persons, animals or property by installation, adjustment, maintenance and misuse errors is excluded.

INDEX

1	General Details	4	6	Use.....	36
1.1	General warnings and safety rules	4	6.1	Description of system components	36
1.2	Description of system components	8	6.2	Manual operation (without remote control)	37
1.3	Accessories	9	6.3	Other functions	37
1.4	Identification	9	6.4	Airflow angle control	37
2	Installation	10	7	Maintenance.....	38
2.1	Product receiving	10	7.1	Cleaning the indoor unit	38
2.2	Size and weight	10	7.2	Cleaning the air filter	38
2.3	Installation - preliminary warnings	10	7.3	Extended periods of inactivity	39
2.4	Installation	11	7.4	Maintenance at the start of the season	39
2.4.1	Installation room	11	7.5	Troubleshooting	40
2.4.2	Hang the indoor unit	14	7.5.1	Common problems	40
2.4.3	Installation of the air duct	20	7.5.2	Anomalies and remedies	41
2.4.4	Preparation for connection pipes	24	7.6	Indoor unit error codes	42
2.4.5	Drainage pipe	24	8	Disposal	43
3	Electrical connections.....	27	9	Attachments	44
3.1	Preliminary information	27	9.1	Indoor unit wiring diagrams	44
3.2	Power cable connection	28	9.2	Declaration of conformity	48
3.2.1	Electrical wiring specifications	28			
3.3	Communication wiring	29			
3.3.1	Communication wiring between the indoor and outdoor units	30			
3.3.2	Communication wiring between the indoor unit and the wired controller	30			
4	Configuration	32			
4.1	Power setting	32			
4.2	Address setting	33			
4.3	DIP Switch settings on main board	33			
5	Running the test	35			
5.1	Checks to perform before running the test	35			
5.2	Running the test	35			

Section dedicated to the USER

1 GENERAL DETAILS

1.1 General warnings and safety rules



WARNING

- This manual is the property of CLIVET and reproduction or transfer to third parties of the contents of this document is prohibited. All rights reserved. It is an integral part of the product; make sure that it is always supplied with the appliance, even in case of sale/transfer to another owner, so that it can be consulted by the user or by personnel authorised to carry out maintenance and repairs.
- Read this manual carefully before using the appliance to ensure its safe operation.
- Periodically check the integrity of the power cable. If the power cable is damaged, it may only be replaced by the manufacturer or the local distributor who sold the appliance or by authorised maintenance and repair personnel.
- Installation must be in accordance with the IEC 61000-3-12 standard.
- The installation must be carried out by an authorised dealer or a qualified technician. Incorrect installation may cause water leakage, electric shock and fire, or cause the appliance to malfunction.
- The installation must be carried out according to the instructions provided. An incorrect installation may cause water leaks, electric shock or fire.
- Perform the installation using only the supplied accessories and parts specified. The use of non-standard components may cause water leakage, electric shock or fire and cause the unit to malfunction.
- Work on the refrigerant circuit must only be carried out by persons with a valid certification, issued by an accredited body, certifying their competence to handle refrigerants safely in compliance with the specifications in force in the sector.
- Use a vacuum pump with a non return valve to evacuate the system. Do not perform an air purge using refrigerant.
- Use deoxidised phosphorous copper piping for the refrigerant (seamless copper alloy piping and tubing). Keep the inner and outer surface of the pipes clean and free of contaminants.
- Store the piping indoors and keep both ends of the pipes sealed until it is time to flare or weld.
- Do not use any means other than those recommended by the manufacturer to accelerate the defrosting process or to clean the unit.
- The appliance must be placed in a room that does not contain any ignition sources (e.g. open flames, gas appliances or electric heaters).
- Weld the pipes purging with nitrogen to avoid oxidation.
- Keep the interconnection cable away from the copper pipe. The temperature of the refrigerant circuit is high.
- Note that the refrigerants are odourless.
- Use only the refrigerants indicated in the manual.
- Recharge the refrigerant when it is in the liquid state.
- After installation, verify that there are no refrigerant leaks.
- Do not touch the components of the refrigerant line during or immediately after operation of the appliance. There is a risk of burns or frostbite.
- Install the connection joints and manifolds referring to the installation manual.
- Install the drainage pipe according to the instructions in this manual. Incorrect draining can cause water seepage or flooding with possible damage to the home and other property.
- Insulate the piping to avoid condensation.

- Always use the specified cables for all electrical work. Connect the cables securely and secure them in a stable manner to prevent the terminals from being damaged by external forces. Incorrect electrical connection may cause overheating conditions and may result in fire and electrocution.
- Install the electrical cables making sure that they are not taut. Otherwise, they could break or overheat causing smoke or fire.
- The cables must be arranged so that the control board cover can close properly. If the control board cover is not closed properly, corrosion may occur and the connection points on the terminals may become hot, ignite or cause electric shock.
- Always disconnect all power supply circuits before touching the terminals for any reason.
- It is advisable to install a Class B or F differential magnetothermic circuit breaker on the power supply line of the appliance.
- For electrical work, comply with the provisions of the national electrical code, local regulations, current regulations and the requirements contained in the installation manual. It is necessary to use an independent circuit and a single power supply socket. Do not connect other appliances to the same electrical outlet. Insufficient electrical capacity or faulty electrical installation may cause risk of electric shock or fire.
- Incorporate in the wiring an omnipolar isolator switch with a separation distance of at least 3mm between all poles and a residual current device (RCD) with a value greater than 10mA. Observe the domestic regulations.
- Replace the fuses only with others of the same value and technical characteristics.
- Install the appliance and its power cables at least one metre away from other electrical equipment in order to avoid interference or noise.
- The appliance must be stored in such a way as to prevent any mechanical damage.
- Consult a qualified technician for unit repair or maintenance.
- Do not modify or alter the safety or protection devices.
- Do not touch the appliance with wet or damp parts of the body as to do so could lead to electric shock.
- Make sure that the power is disconnected before performing any service or maintenance.
- If you notice any anomalies (e.g. a burning smell), stop the appliance, turn off the power switch and consult your dealer.
- Make sure that the air inlet and outlet are not blocked as this could trigger the protective device that stops the appliance.
- This appliance is intended for use on commercial premises by experienced or suitably trained users
- This appliance is designed to cool or heat spaces intended for the presence of human beings. It must not be used to cool or heat food, plants, animals, machinery, equipment or works of art.
- Read this manual carefully before using the appliance to ensure its safe operation.

**CAUTION DANGER**

- When connecting refrigerant piping, keep substances or gases other than the specified refrigerant from entering the unit. The presence of other gases or substances can reduce unit performance and cause an abnormal increase in pressure in the refrigeration cycle. This can lead to explosion hazards and resulting injuries.
- Install the unit on a stable stand that can support its weight. If the chosen stand cannot support the weight of the unit, or if the installation is not performed correctly, the unit may fall and cause injury and serious damage.
- Do not pierce or ignite the appliance.
- The appliance must be placed in a well-ventilated room whose dimensions correspond to those specified for operation.
- The product must be installed with earthing in accordance with the law to avoid the risk of electrocution. Do not connect the earth cable to gas or water mains, lightning rods or phone earth cables.
- Install an earthing connection switch. Failure to install this can result in electric shock.
- Do not operate the appliance if the protections have been removed.
- Do not install the unit:
 - in a location that can be exposed to combustible gas leaks. Any accumulation of combustible gas around the unit may cause a fire hazard;
 - near the coast (except in the case of corrosion resistant models);
 - near a source of hot water due to the presence of caustic gas in the air;
 - in the presence of strong electromagnetic waves;
 - in the presence of significant voltage flicker;
 - in the presence of acid or alkaline liquid that evaporates;
 - in the presence of flammable materials or gas.
- Wear the required PPE (protective gloves) during installation and maintenance. High pressure piping poses a risk of burns during operation.
- Measure the insulation resistance and make sure it is at least $1M \Omega$ once the wiring work is done.
- Do not use flammable paints, enamels, sprays or other products that may release flammable fumes or vapours near the appliance as they could cause fires.
- Do not install open flame units near the appliance. The heat released could ruin it.
- Do not insert your fingers between the fans during operation. This could lead to injury.
- Do not allow children to play near the unit as it may cause injury.



IT IS PROHIBITED TO

- Make changes and/or repair attempts to the product. Any repairs must be carried out by a qualified technician.
- Touch the appliance with wet, damp and/or barefoot body parts. If you notice current leakage that can be detected on contact with metal parts of the appliance, disconnect the switch, unplug it from the power supply socket and contact an authorised dealer.
- Disperse in the environment and leave within the reach of children the packaging material as it may be a potential source of danger. It must therefore be disposed of in accordance with current legislation.
- Use the same electrical outlet for other appliances. Incorrect or insufficient power supply may cause fire or electric shock hazard.
- Connect the electric air conditioner to the power supply before having finished wiring the power lines and pipes. Connect the cables of the outdoor unit and then those of the indoor unit.
- Perform maintenance in the rain. Electrical leakage, electric shock, short circuit, malfunction, smoke or fire may occur.



Notes on fluorinated gases

- This air conditioner contains fluorinated gas. For specific information on gas types and quantities, please refer to the plate found on the unit. It is always necessary to comply with national regulations regarding the use of gases.
- Installation, service, maintenance and repair of the unit must be performed by a qualified technician.
- The uninstallation and recycling of the product must be carried out by qualified technical personnel.
- If a leak detection device is installed in the system, it is necessary to check that there are no leaks at least every 12 months. When checking the unit for leaks, it is recommended to keep a detailed record of all inspections.
- Pay attention to the fact that refrigerant R410A is odourless.

1.2 Description of system components

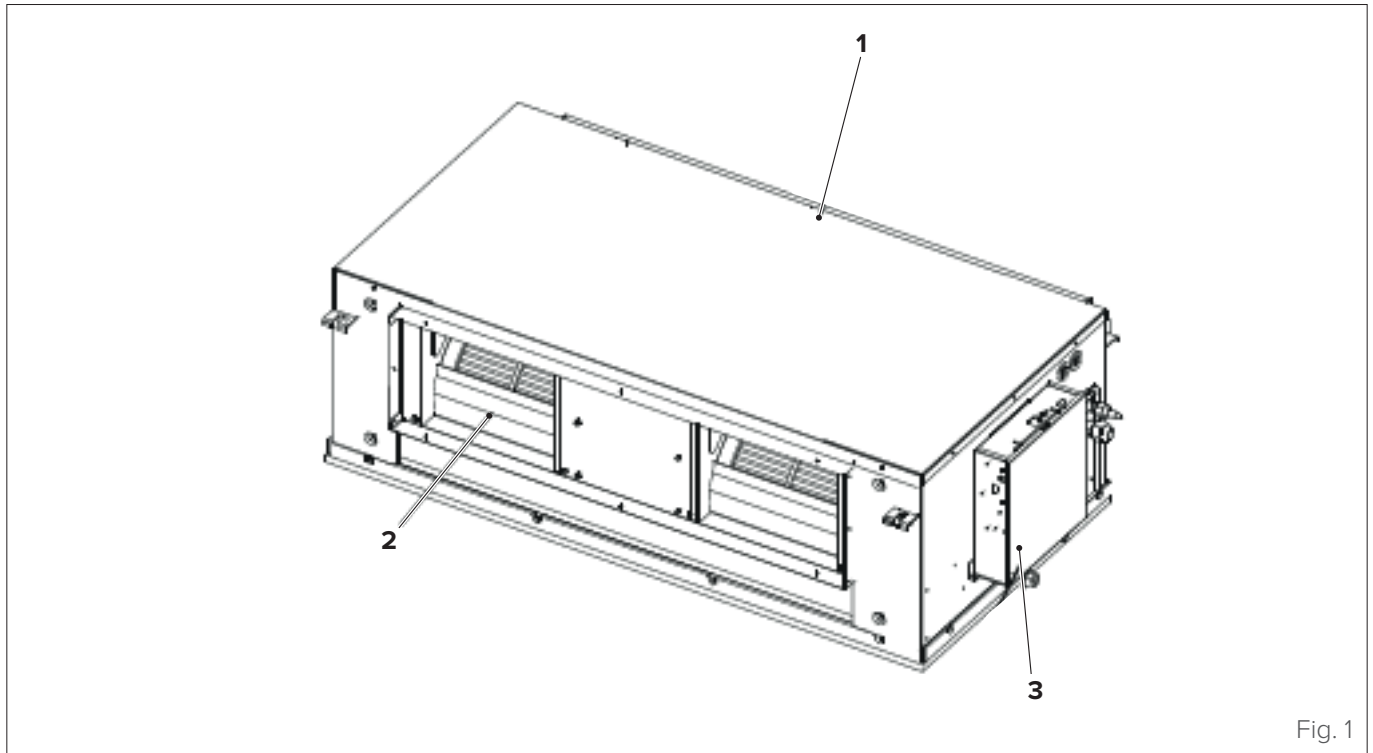

Fig. 1







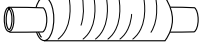

- 1 Air inlet
- 2 Air outlet
- 3 Electrical panel

**WARNING**

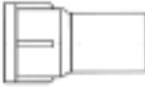



The images in this manual are provided for illustrative purposes only. The appearance of your appliance may differ slightly from the illustrations shown here. Refer to the actual characteristics of the unit.

1.3 Accessories

The air conditioning system is provided with the following accessories. Use all specified installation components and accessories to install it.

Description	Aspect	Quantity
Piping insulation		2
Flexible water drain hose		1
Hose clamp		1
Brass nut		2
Water connection pipe		2
Adhesive tape for gasket		2
Foam		2
Remote display		1
Connection cables		1
Wire ON/OFF		1
Installation manual		1

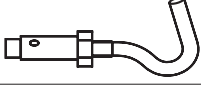
Accessories not supplied

Description	Aspect	Notes
Copper piping		Use to connect the internal refrigerant piping.
PVC water drain piping (outer Ø: 37-39 mm, inner Ø: 32 mm)		Use to drain condensate from the indoor unit.
Piping insulation		Protect the piping from condensate.
Hook with M10 expansion bolt		4 for indoor unit installation
M10 rods		4 for indoor unit installation
Cable tie		To be purchased on the basis of actual project requirements.

1.4 Identification

The indoor unit can be identified by the serial number label that shows the technical and performance data of the appliance and what is required by the legislation in force.

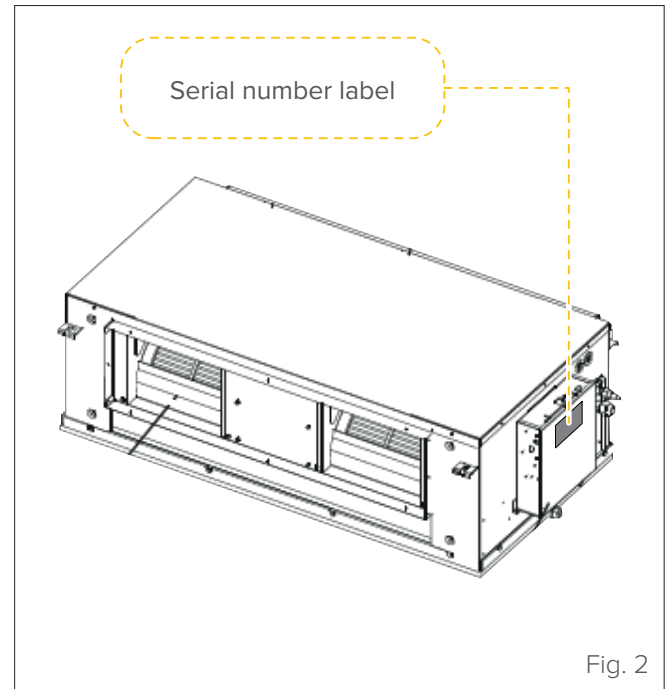

Fig. 2



CAUTION

Tampering, removal, lack of identification labels or anything else that does not allow safe product identification, makes any installation and maintenance operation difficult.

2 INSTALLATION

2.1 Product receiving

The appliance is supplied packed in several parcels. Handling must be carried out by appropriate means in view of the overall weight of the package.

Upon receiving the appliance, check the perfect integrity of all parts.

In case of damage to the appliance or missing material, please contact your authorised dealer promptly.



WARNING

The manual is an integral part of the product and therefore it is recommended that you read it before installing and commissioning the appliance and keep it with care for future reference or transfer to another Owner or User.



IT IS PROHIBITED TO

disperse the packaging material in the environment and leave it within the reach of children as it can be a potential source of danger. It must be disposed of in accordance with current legislation.



WARNING

During all handling operations, use the appropriate PPE such as hard hat, gloves and safety shoes.

2.2 Size and weight

	Width (mm)	Depth (mm)	Height (mm)	Weight (kg)
D71	965	690	423	41
D80	965	690	423	41
D90	965	690	423	51
D112	965	690	423	51
D140	1322	691	423	63
D160	1322	691	423	63
D200	1454	931	515	130
D250	1454	931	515	130
D280	1454	931	515	130
D400	2010	905	680	210
D450	2010	905	680	210
D560	2010	905	680	218



CAUTION

Handle the appliance with the hooks. Do not exert any force on other parts of the unit, especially on refrigerant and water drain pipes and plastic parts.

2.3 Installation - preliminary warnings



WARNING

Before installing the indoor unit, consult the label on the product package to check that the model number matches the model number of the outdoor unit.



CAUTION

All installation operations must be carried out with the appliance completely stopped and after disconnecting all external power supplies. Before any installation work, pay close attention to the labels on the appliance. During the activities you must not tamper with or disconnect safety devices for any reason, create by-passes, or use them for purposes other than those envisaged by the manufacturer.

Below are the guidelines for achieving a compliant installation.

- Identify a suitable area for installation.**
See [“2.4.1 Installation room”](#) page 11
- Put the appliance in place.**
See [“2.4.2 Hang the indoor unit”](#) page 14
- Lay the refrigerant piping.**
- Perform correct installation of the condensate drain piping.**
- Clean the refrigerant piping.**
- Make the refrigerating connections.**
- Test the tightness of the system at the pressures indicated by the manufacturer.**
- Carry out the correct pressurisation of the system.**
- Carry out the electrical wiring, configurations and addressing according to the diagrams provided.**
See [“3 Electrical connections”](#) page 27



ATTENTION ELECTRIC DANGER

- All electrical connections must be done by a licensed electrician according to the provisions of national and local electrical codes.
- All electrical connections must be made according to the wiring diagram on the panels of the indoor and outdoor units.
- If the electrical system has serious safety problems, stop work immediately. Explain the situation to the customer and refuse to install the unit until the safety problem has been resolved.
- The power supply should correspond to 90–100% of the rated voltage. Insufficient power supply may cause malfunction, electric shock or fire.
- If the power cables are permanently installed connected to the electrical system, install overcurrent protection and a main power switch with a capacity of 1.5 times the maximum current of the unit.
- The power supply line must have a special protection upstream against short circuits and earthing leakage that sections the system with respect to other utilities. The technician must choose an approved differential circuit-breaker or main circuit breaker.
- Connect the unit to a single socket of a dedicated branch of the circuit. Do not connect other appliances to the same electrical outlet.
- The air conditioner must be properly grounded.
- All cables and conductors must be connected securely. Loosening a conductor may cause the terminal to overheat, which in turn may result in fire hazards or product malfunction.
- The electrical cables must not touch or rest against the refrigerant pipes, the compressor or any moving parts of the unit.

Outdoor air handling units can be used either alone or combined with other types of indoor units. If used alone, the total capacity of the outdoor air handling units must be between 50% and 100% of that of the outdoor units. If used with other types of indoor units, the total capacity of the indoor units and outdoor air handling units must be between 50% and 100% of that of the outdoor units and the total capacity of the outdoor air handling units must not exceed 30% of that of the outdoor units.

2.4 Installation

2.4.1 Installation room



CAUTION

The appliance must be placed in a well-ventilated room, with a minimum surface area that varies according to the amount of refrigerant present.



CAUTION

If the indoor room temperature and the relative humidity exceed 30°C and 80%, attach insulation materials that are more than 10mm thick to the unit casing.

The following information can help you choose a suitable location.

The installation location must have the following characteristics:

- good air circulation.
- ease of drainage.
- the noise emitted by the unit must not disturb other people.
- stability and robustness - no exposure to vibration.
- sufficient capacity to support the weight of the unit. If the structure is too weak, the unit can fall and cause serious or fatal personal injury, material damage and damage to the appliance.
- at least one metre away from any other electrical device (e.g. TV, radio, computer).
- installation at a height of 2.5 m to 3.5 m off the ground.
- if the indoor unit is installed on a metal bracket, it must be earthed.
- the unit must be at least 1m away from the nearest wall.
- the space must be sufficient for installation and maintenance operations.
- the space must be sufficient for connection of the piping and drain pipe.
- the ceiling must be horizontal and its structure must be strong enough to support the weight of the indoor unit.
- the air inlet and outlet must not be blocked.
- The airflow must be able to reach the whole room.
- The static pressure of the indoor unit air duct is within the permissible range.



It is **PROHIBITED** to install the indoor unit in the following locations:

- in a bathroom or laundry room, because excess humidity can reduce its service life and corrode the cables;
- near sources of heat, steam or combustible gas;
- near flammable objects, such as curtains or fabrics;
- near obstacles that could obstruct air circulation;
- near the entrance;
- in an area that is not exposed to direct sunlight;
- areas exposed to strong electromagnetic waves;



It is **PROHIBITED** to install the indoor unit in the following locations:

- oil extraction drilling or fracking areas;
- coastal areas with extremely salty air;
- areas with an atmosphere impregnated with caustic gases, for example near thermal sources;
- areas subject to strong power fluctuations, for example factories;
- enclosed spaces (cabinets, etc.);
- kitchens with natural gas cooker hobs;
- areas used for storing gas or flammable materials.

Distances:

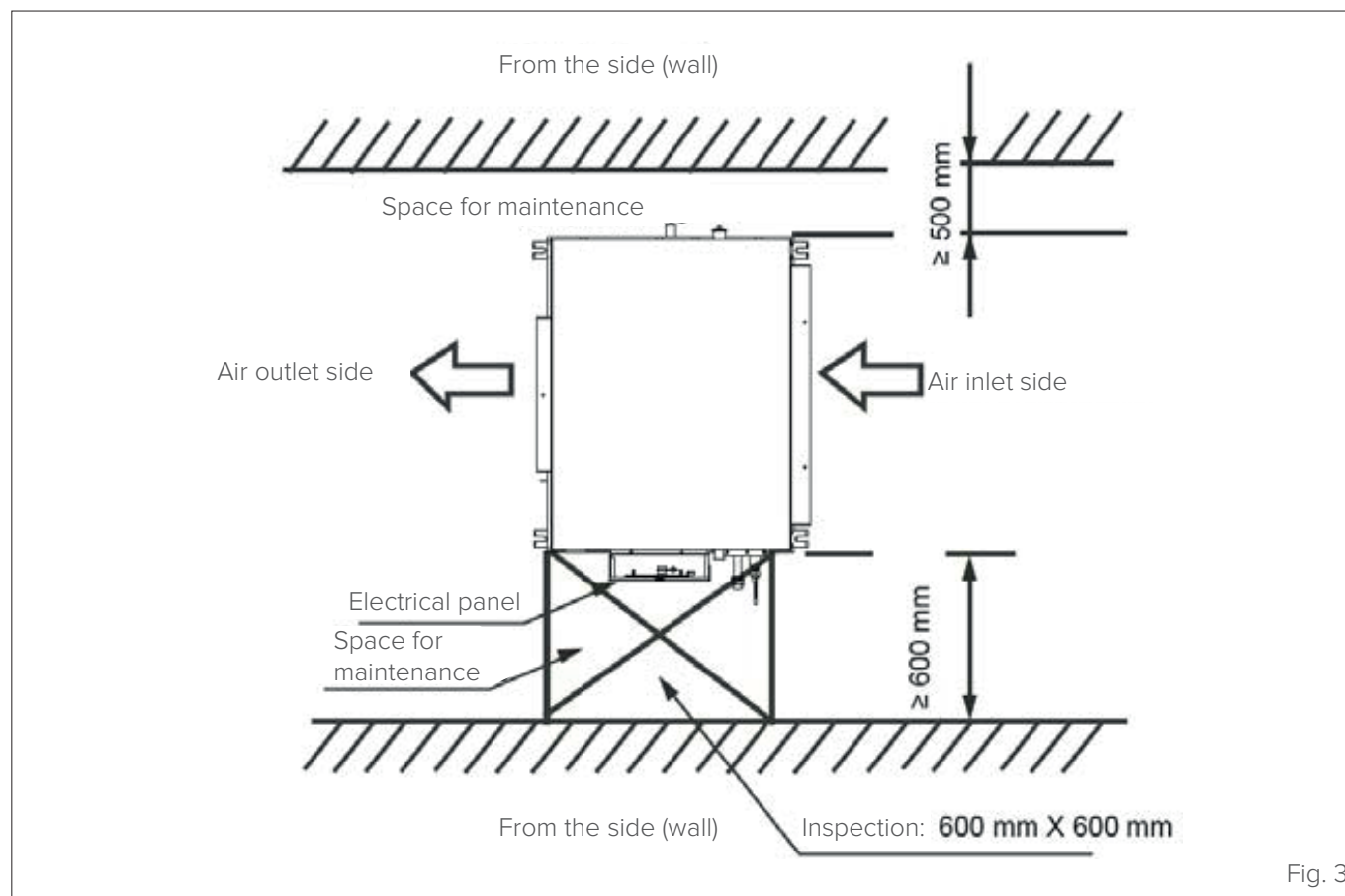

Fig. 3

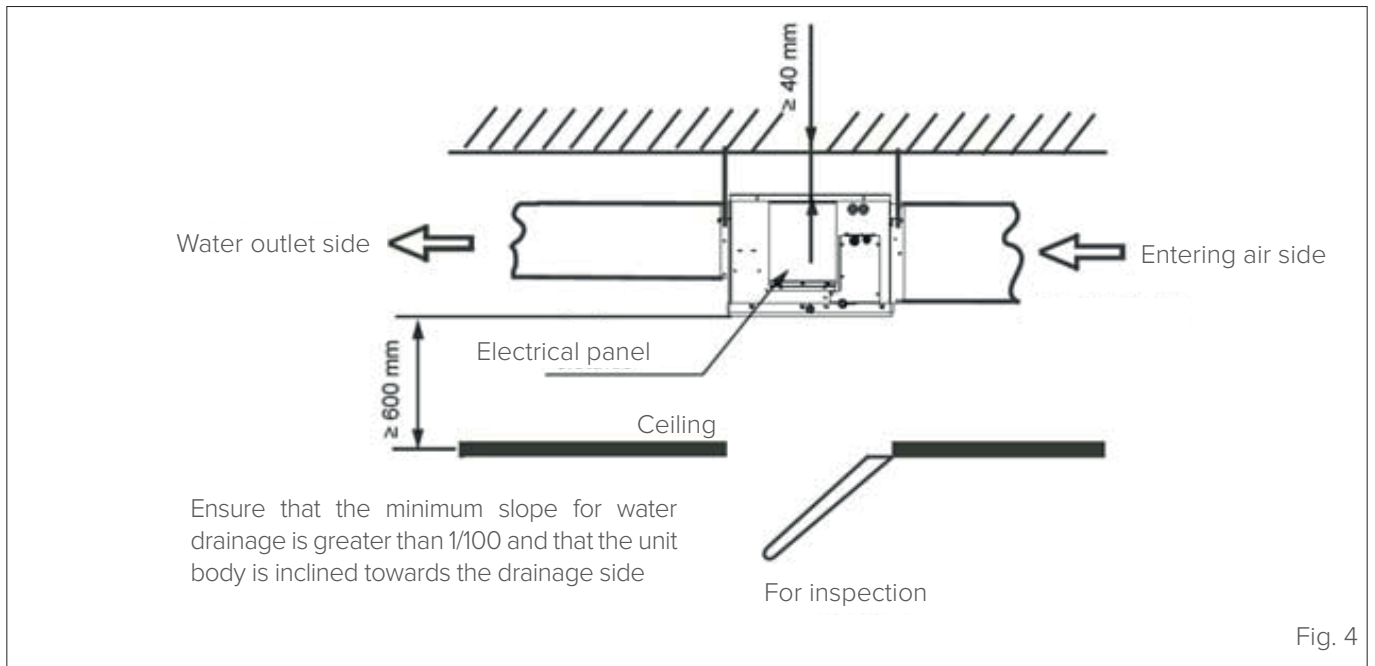

Fig. 4

2.4.2 Hang the indoor unit

Size:
7.1 ÷ 11.2 kW

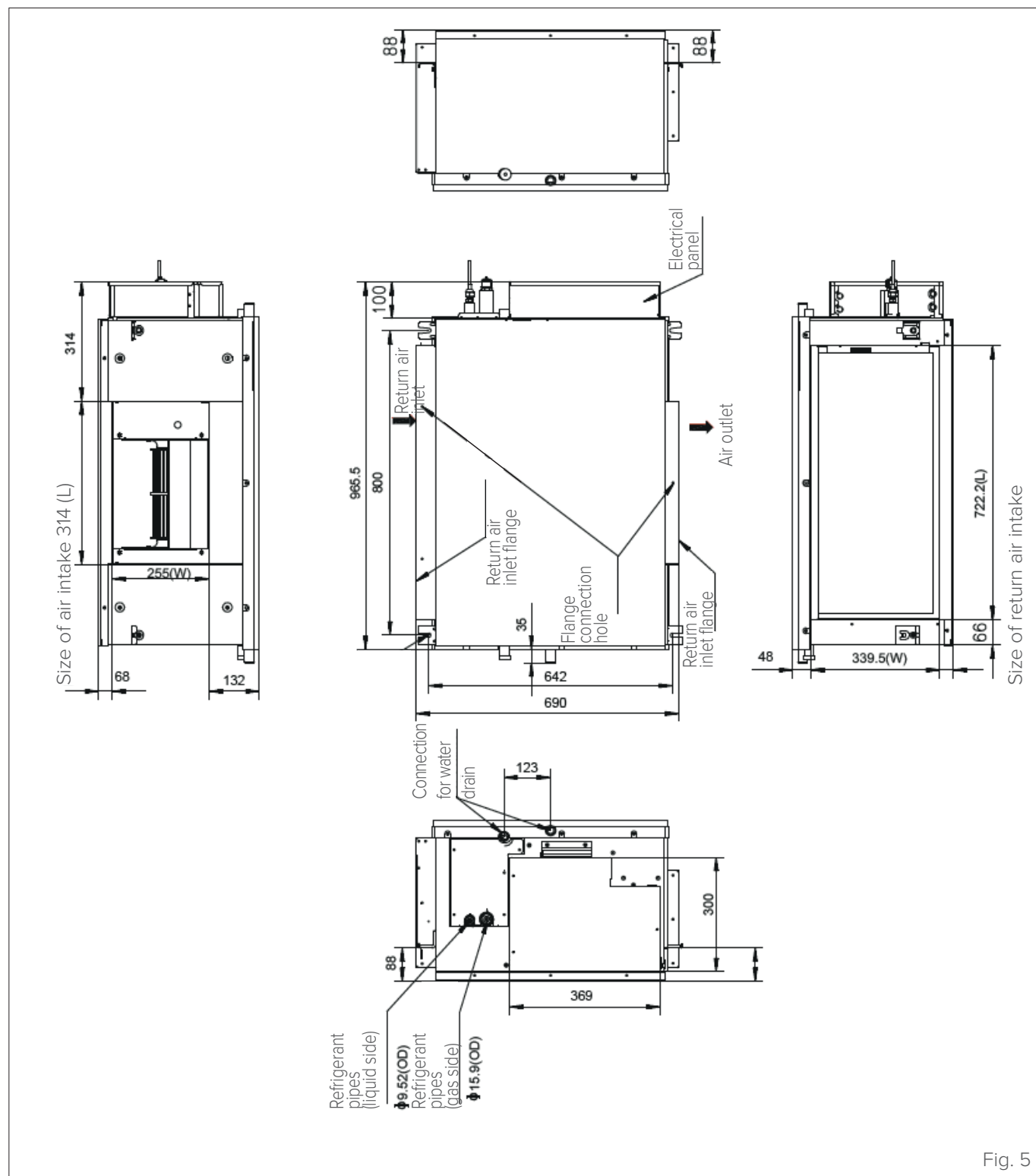

Fig. 5

14 ÷ 16 kW

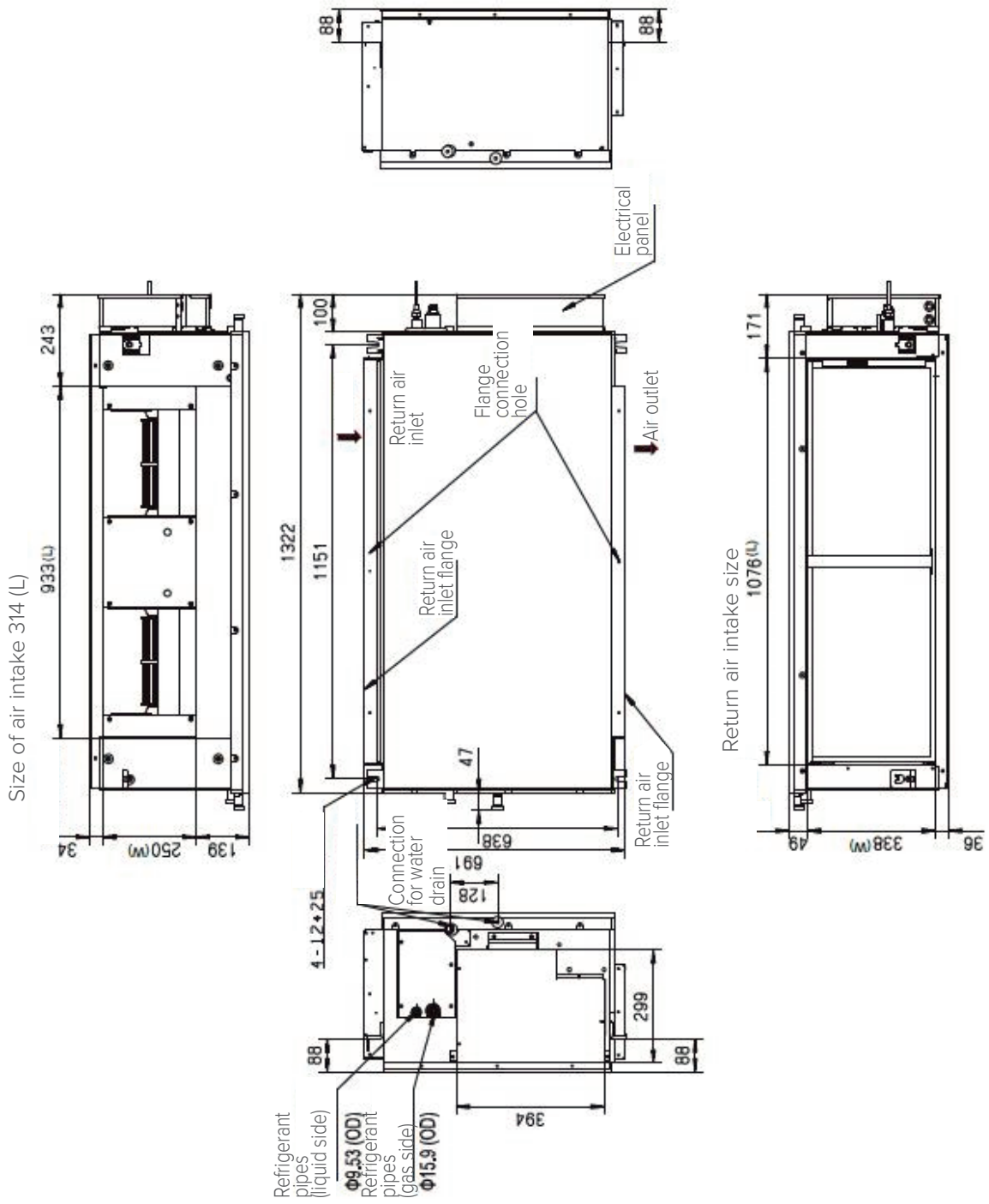

Fig. 6

20.0 ÷ 28.0 kW

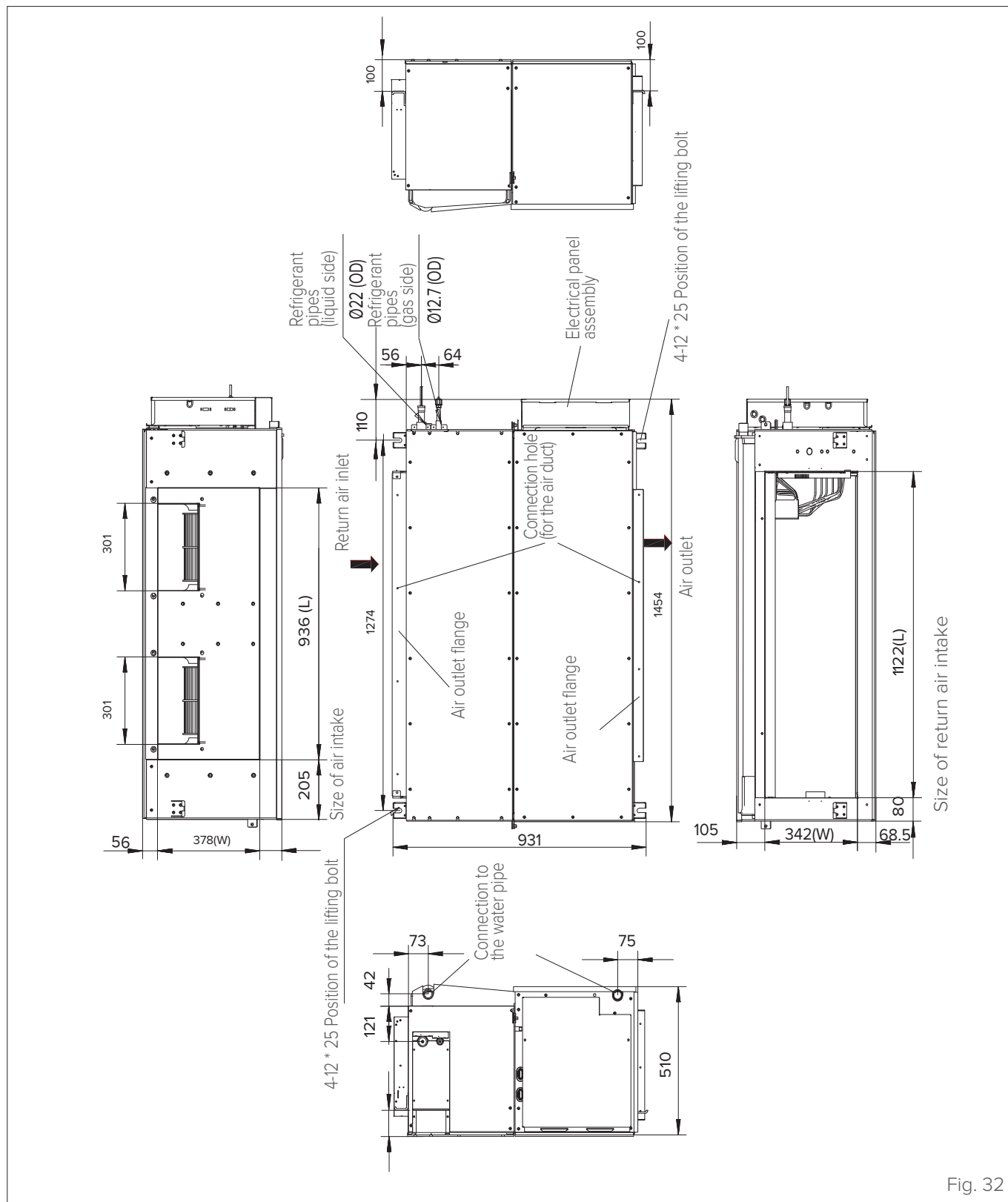

Fig. 32

40.0 ÷ 56.0 kW

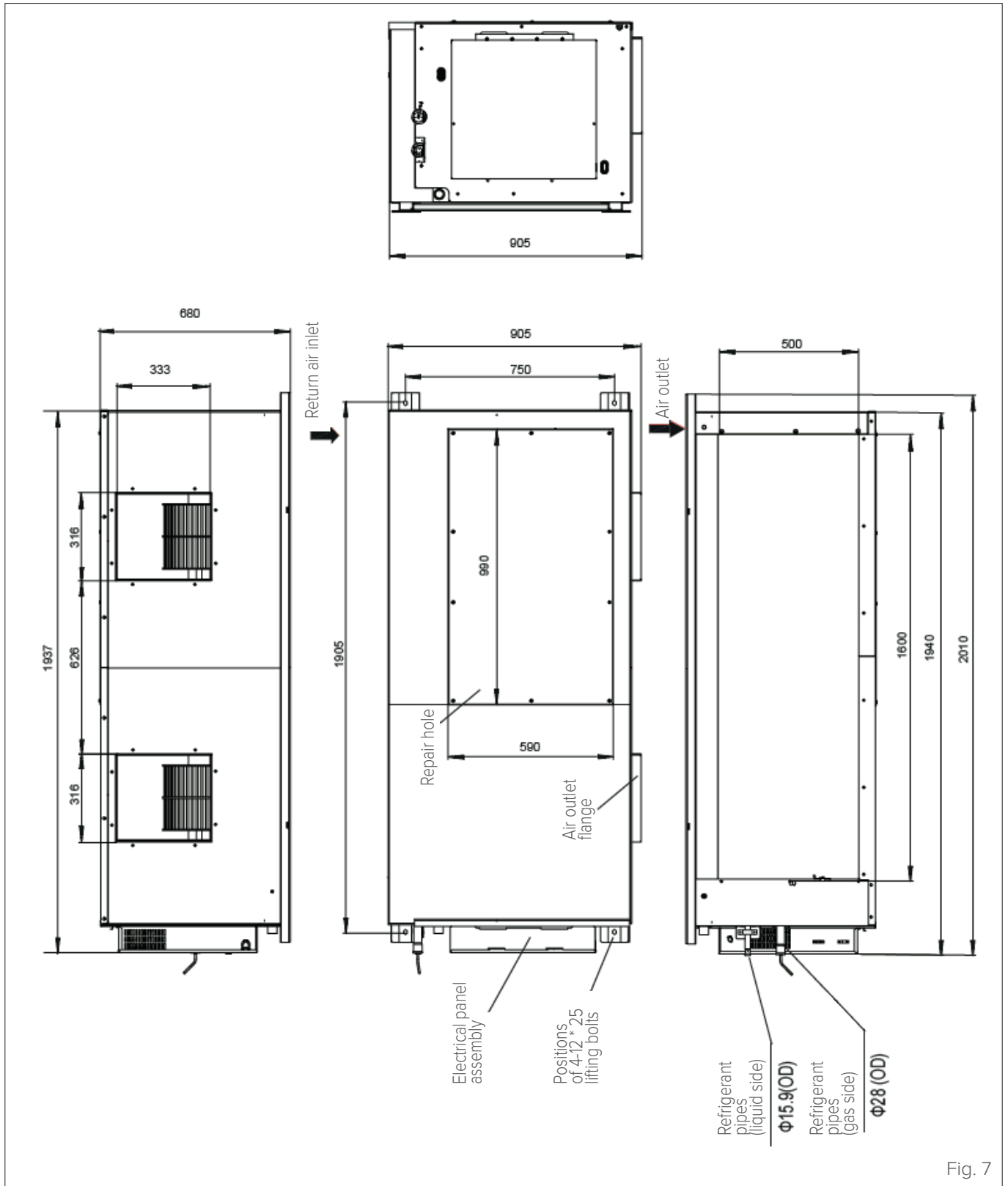
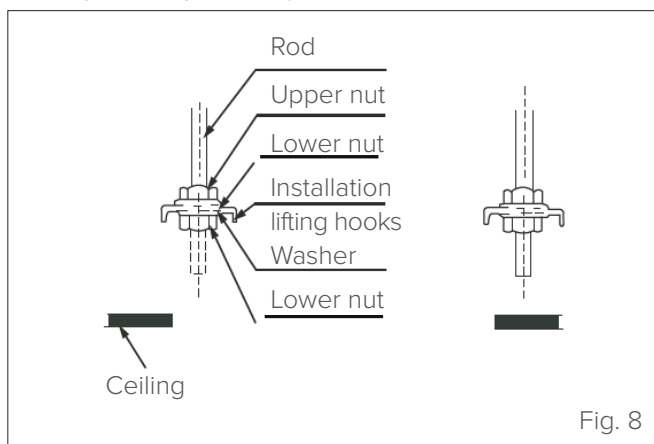
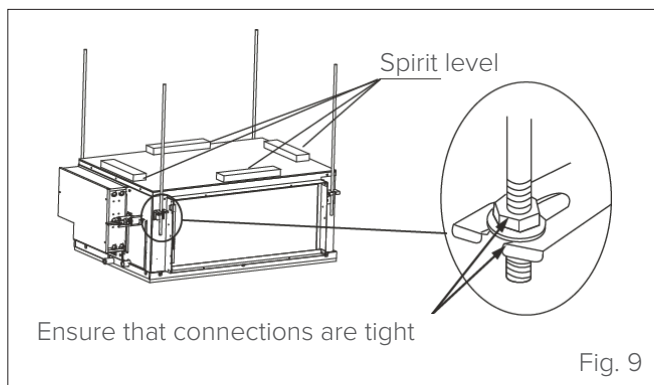

Fig. 7

- 1 To assemble the indoor unit's eye bolts on the suspension rings, fit the tie rod's nut and washer into the long opening of the eye bolts.



- 2 Adjust the height of the indoor unit.
- 3 Use a spirit level to check that the unit casing is aligned (sliding the unit casing down, drainage side).



– **Roof with wooden structure**

Place the wooden assembly panel crosswise over the roof beam, then install the anchor rods

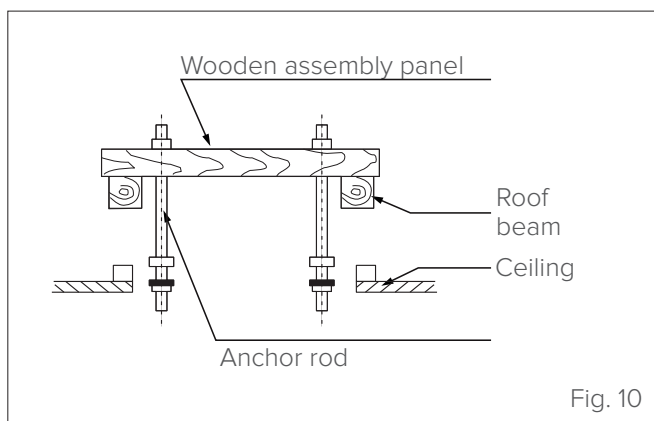

– **New concrete slab**

Embed the anchor rods.

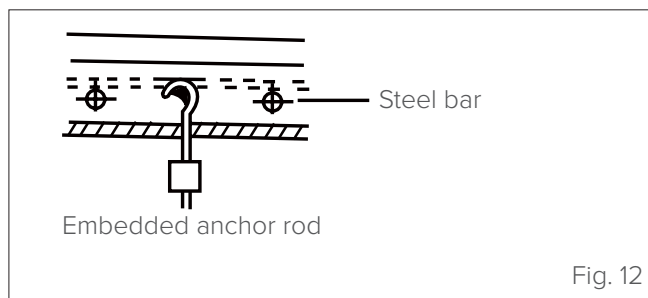
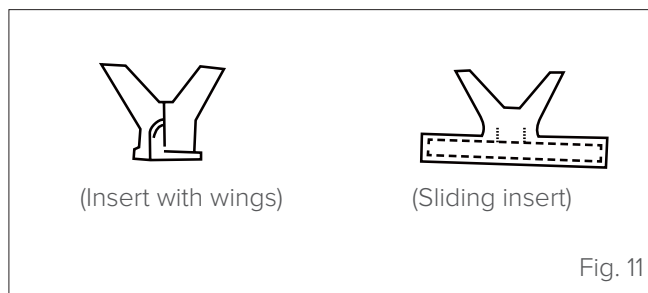

– **Existing concrete slab**

Install the suspension hook with expansion anchor 45~50 mm deep in the concrete to prevent it from loosening.

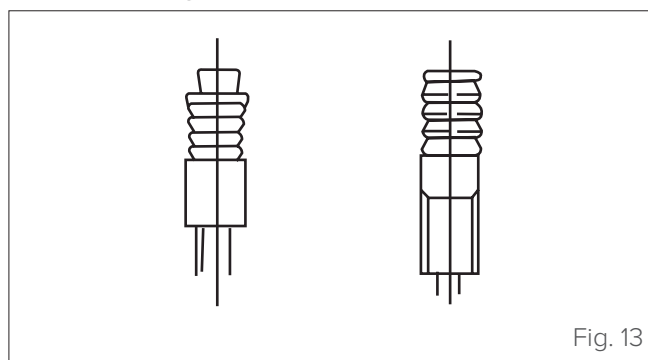

– **Roof with steel structure**

Install and use the angled steel brackets

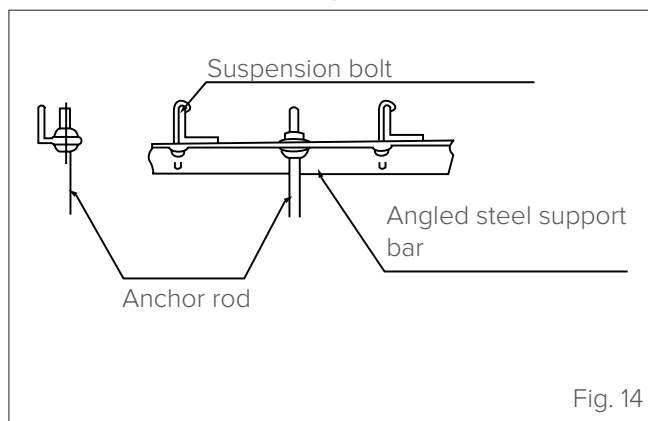

- 4 Install the four anchor rods (M10).
- 5 Determine the length of the rods based on the height of the ceiling. Remove the surplus part.

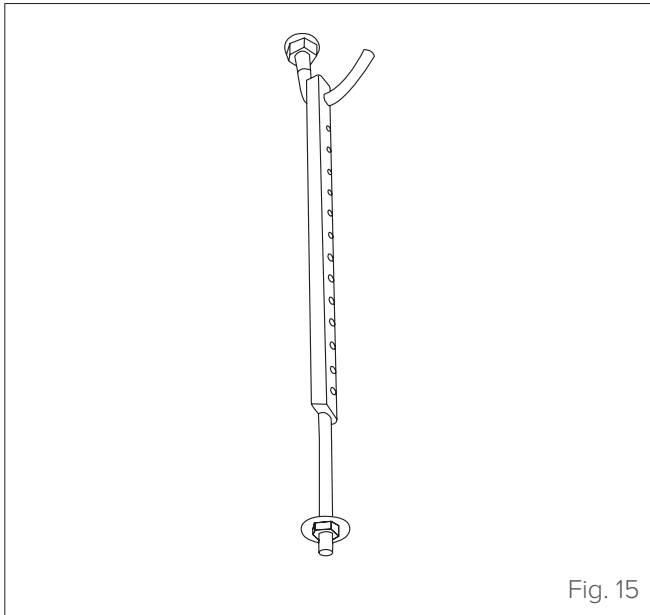

WARNING

Check that the indoor unit is horizontal. The unit has a drain pump and a float switch. If the unit tilts in the opposite direction to that of the condensate flow (with the drain pipe side raised), the float switch may not work properly and cause a water leak.

- 7 Use the hexagonal nuts on the four assembly hooks to adjust and ensure that the unit's casing is level.
- 8 Adjust the position of the unit's casing and ensure that the gap with the ceiling is even on all four sides.
- 9 Once the position of the casing has been adjusted, tighten the nuts to secure the unit.



CAUTION DANGER

The unit body must be aligned exactly with the hole. Before proceeding, check that the hole is the same size as the unit.

- 6 Assemble the indoor unit. Two people are needed to lift and fasten the unit. Insert the anchor rods into the unit's attachment holes. Fasten them with washers and hexagonal nuts.

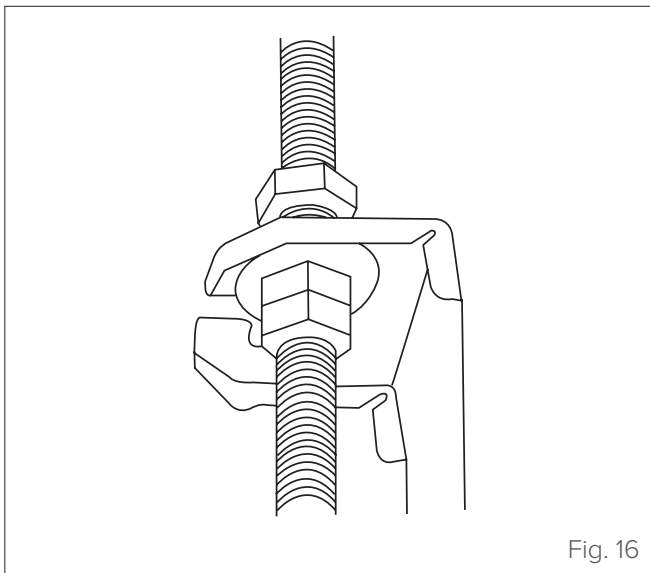

CAUTION DANGER

Check that the unit is completely horizontal. Incorrect installation can cause the drain pipe to go back into the unit or possible water leaks.

2.4.3 Installation of the air duct

- To prevent the air supply circuit from short-circuiting, the air drain and return pipes must not be too close together.
- The indoor unit does not have an air filter installed. The filter should be installed in a position in the air inlet where it is easy to carry out maintenance. (Without an air filter, dust particles can end up on the heat exchanger, which can lead to air conditioner faults and air leaks).
- Connect the insulation pipe to the air drain and return ducts to prevent vibrations from the indoor unit from reaching the ceiling.
- Use 25 mm thick or more thermal insulation materials to prevent condensation on the air duct.
- Connect the air duct. All components require on-site preparation except for the air conditioner.

Unit duct with static pressure requirements

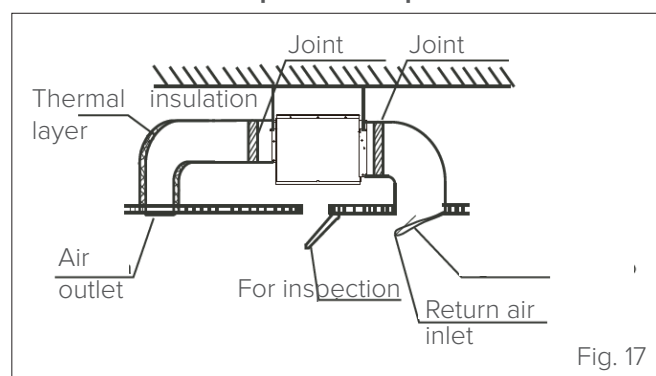

WARNING

Once the air conditioner casing and the fabric joints are riveted together, the flanged plate must be fastened with the screws. (12 M6 screws are prepared on site.)

Fan performance
7.1/8.0 kW

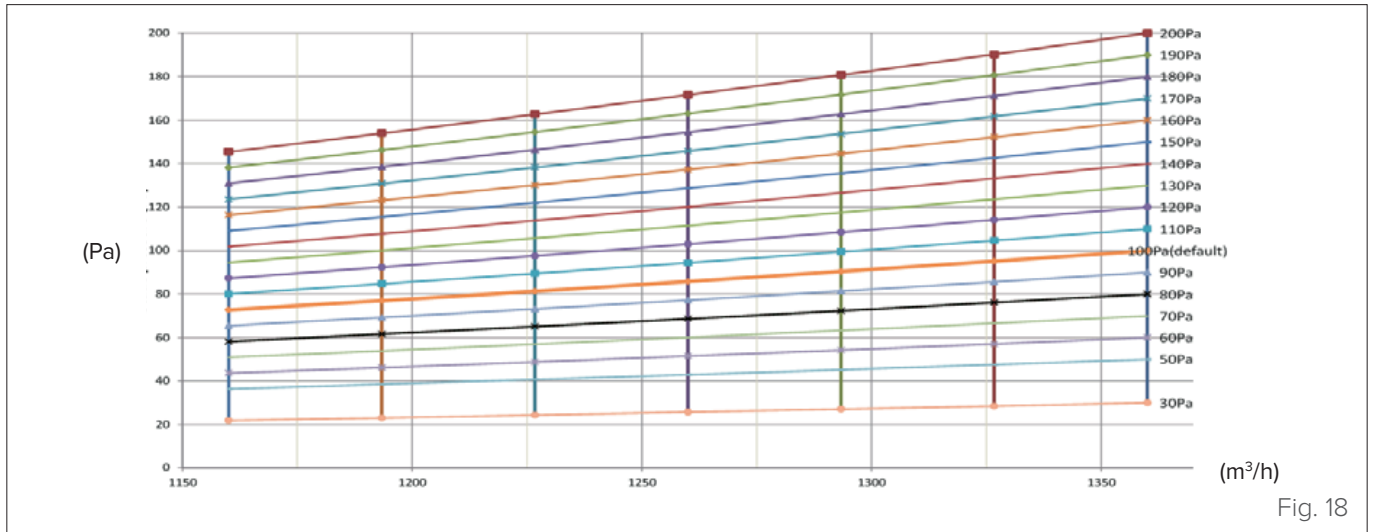

Fig. 18

9.0 kW

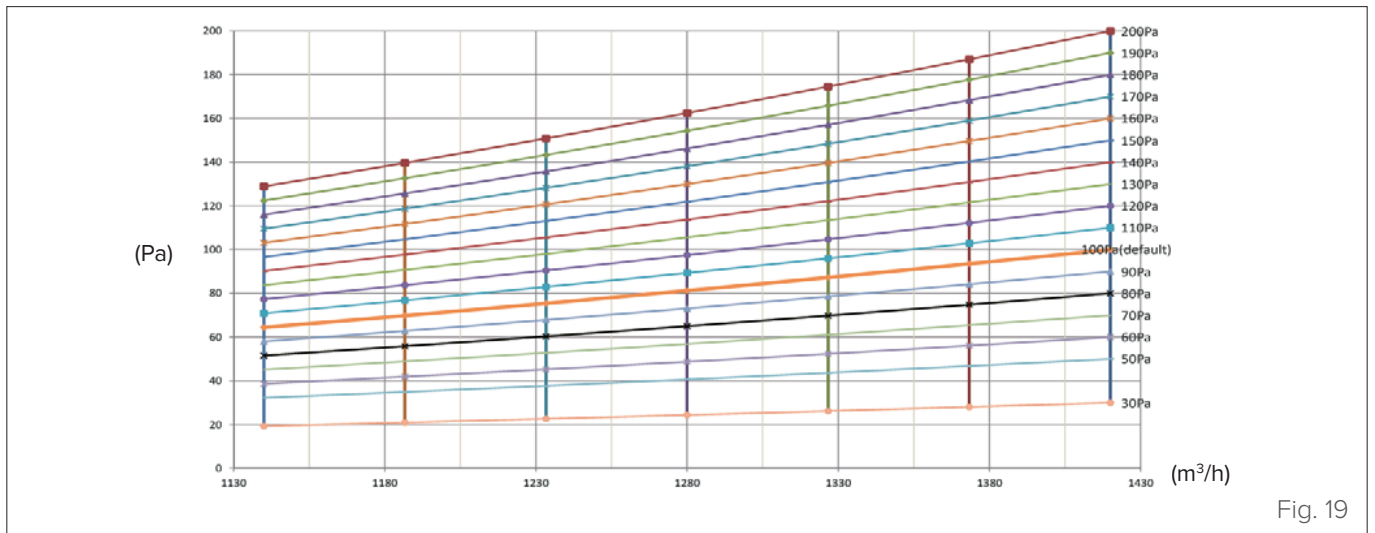

Fig. 19

11.2 kW

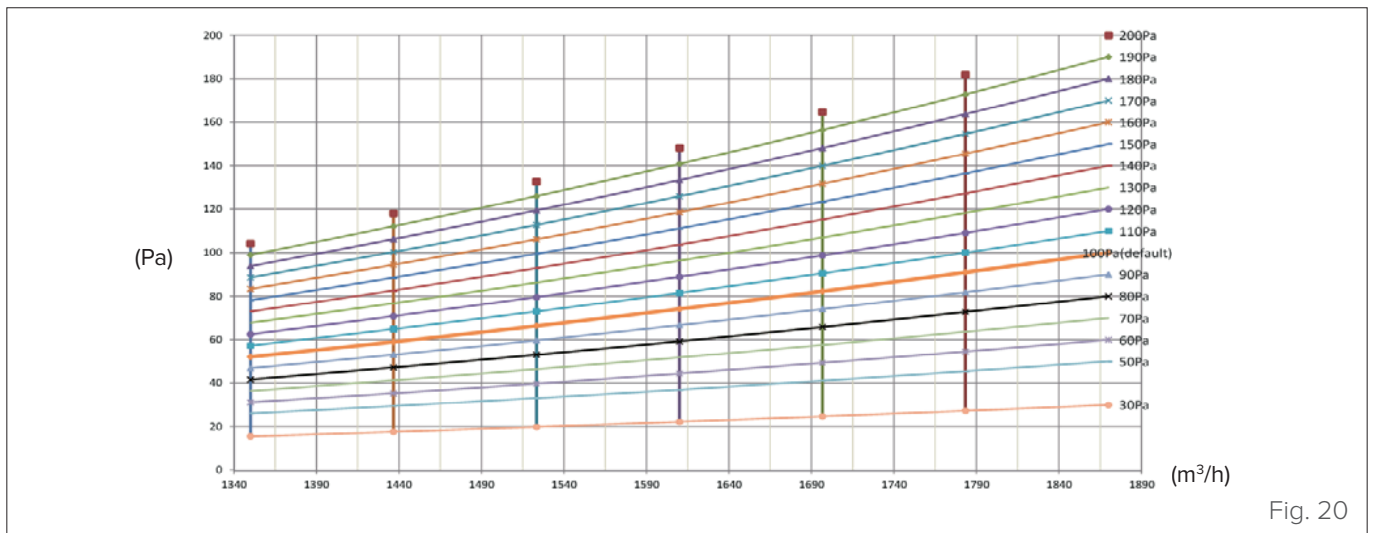

Fig. 20

14 kW

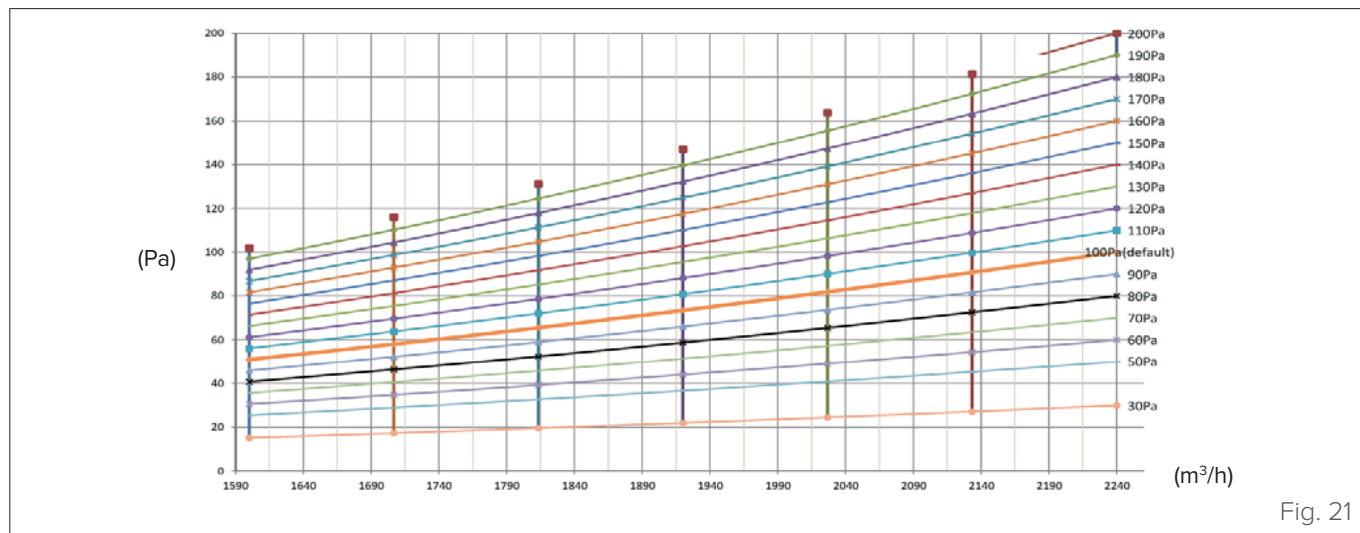

Fig. 21

16 kW

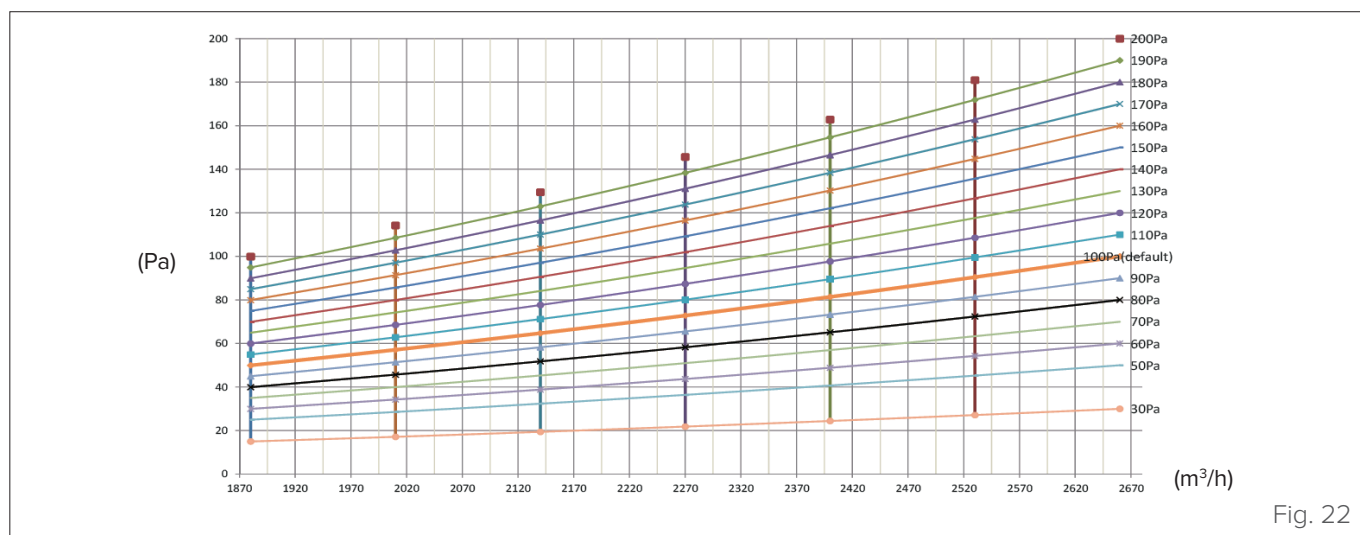

Fig. 22

20.0/25.0/28.0 kW

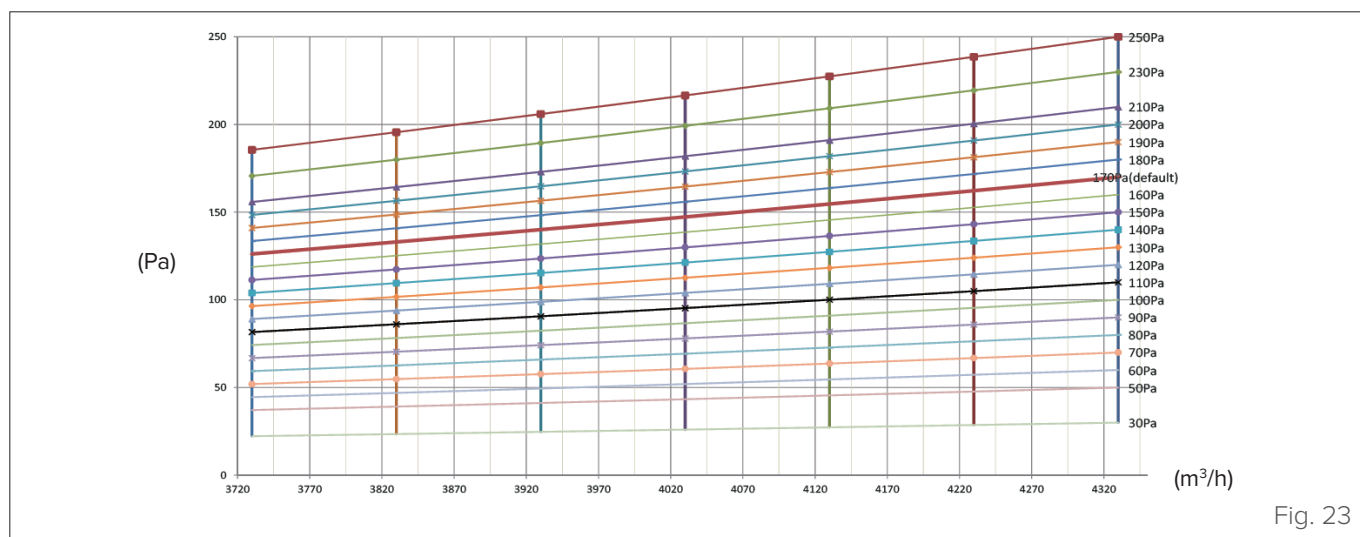
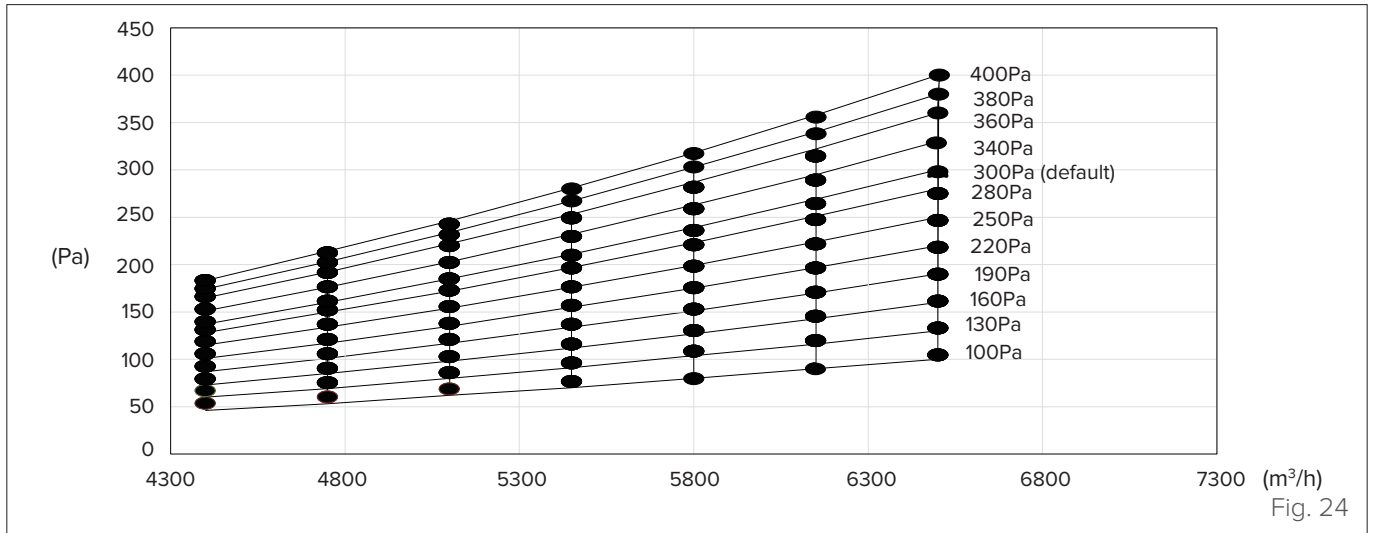
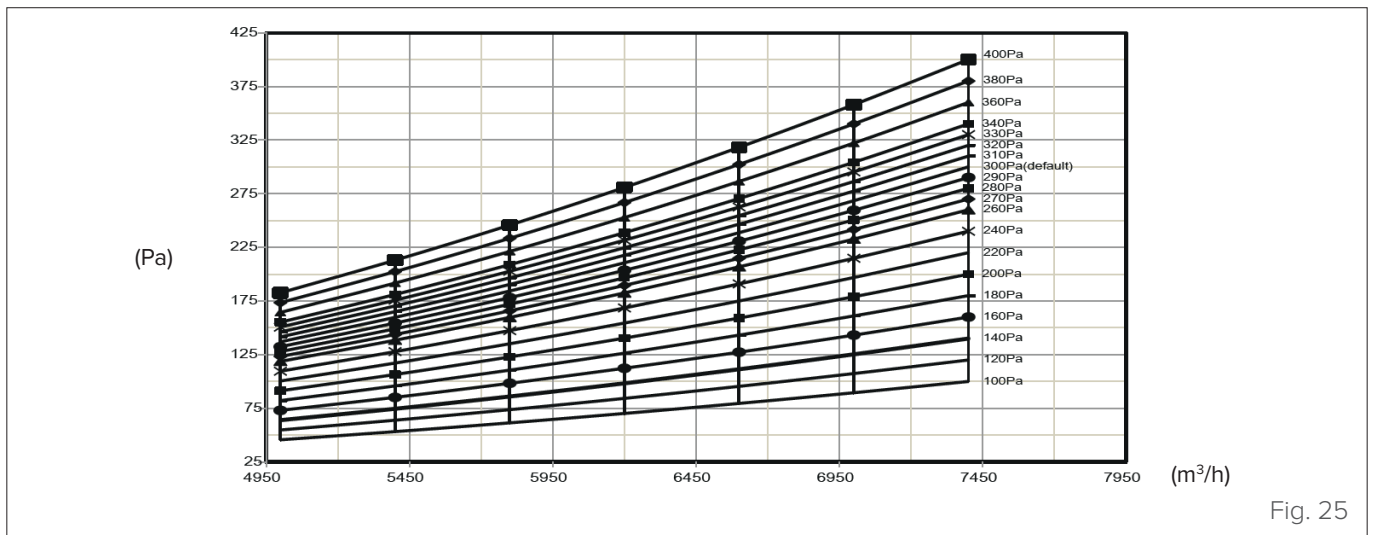

Fig. 23

40/45 kW



56 kW



Set the correct external static pressure (ESP) according to the actual installation conditions. Otherwise, problems may occur.

- If the connection duct is long and the ESP setting is low, the air flow will be very weak, resulting in poor performance.
- If the connection duct is short and the ESP setting is very high, the operating noise will be higher and water may be blown out of the air outlet.
- The ESP can be set with DiP switch SW2 on the main board or the new wired controller. Please refer to the ““DIP Switch settings on main board” on page 33” paragraph for the SW2 setting or the wired controller manual for the wired controller setting.

Up to four ESPs can be set with DIP Switch SW2.

Capacity [kW]	ESP1 [Pa]	ESP2 [Pa]	ESP3 [Pa]	ESP4 [Pa]
7.1÷16.0	100	50	170	200
20.0÷28.0	170	100	200	250
56	300	100	200	400

Up to twenty ESPs can be set with the new wired controller.

Capacity [kW]	00 [Pa]	01 [Pa]	02 [Pa]	03 [Pa]	04 [Pa]	05 [Pa]	06 [Pa]	07 [Pa]	08 [Pa]	09 [Pa]
7.1÷16.0	30	50	60	70	80	90	100	110	120	130
20.0÷28.0	30	50	60	70	80	90	100	110	120	130
56	100	120	140	160	180	200	220	240	260	270

Capacity [kW]	10 [Pa]	11 [Pa]	12 [Pa]	13 [Pa]	14 [Pa]	15 [Pa]	16 [Pa]	17 [Pa]	18 [Pa]	19 [Pa]
7.1÷16.0	140	150	160	170	180	190	200	200	200	200
20.0÷28.0	140	150	160	170	180	190	200	210	230	250
56	280	290	300	310	320	330	340	360	380	400

2.4.4 Preparation for connection pipes

It is necessary to make a hole in the wall where the refrigerant piping, drainage pipe and electrical cables that will connect the indoor unit to the outdoor unit will pass through.

- 1 Determine hole position in the wall according to the position of the outdoor unit.
- 2 Drill the hole in the wall using a 65 mm drill bit. The hole should have a slight inclination, so that the outer end is lower than the inner one by about 12 mm. This will facilitate water drainage.

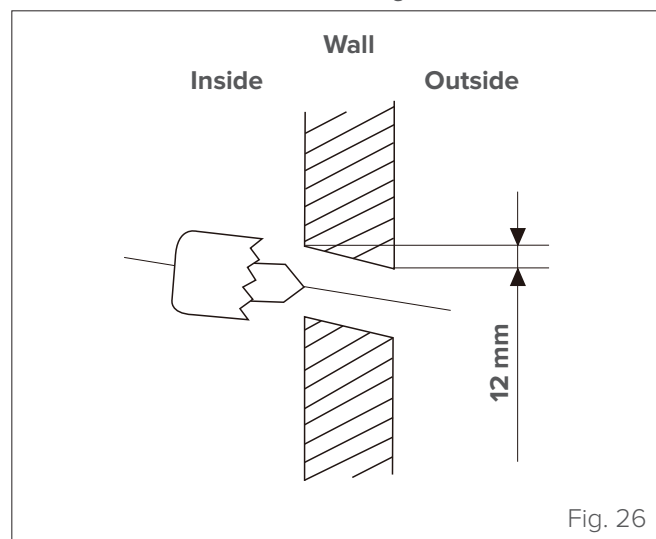

- 3 Insert the protective sleeve into the wall, which will protect the edges of the hole and improve the seal after installation.



CAUTION DANGER

When drilling holes, pay attention to avoid electrical wires, hydraulic hoses and other delicate components.



CAUTION

The drain pipe outlet must be at least 5 cm from the floor. If it touches the ground, the unit can block and not work properly. If the water is discharged directly into the sewer system, use a U- or S-shaped drain pipe to block odours which would otherwise flow back inside.

2.4.5 Drainage pipe

The drainage pipe is used to drain the water from the unit. Incorrect installation can cause damage to the unit and other material damage.



CAUTION DANGER

- Insulate all of the pipes to prevent condensate from forming, which could cause water damage.
- If the drainage pipe is bent or not installed properly, the water can escape and cause the float switch to malfunction.
- In HEAT mode, the unit discharges water. Make sure that the drainage pipe is in a suitable area to avoid water damage and slipping hazards caused by the discharge water freezing.
- **DO NOT** pull the drainage pipe, as this could detach it.



WARNING

This installation requires a polyethylene pipe (outer diameter = 37-39mm, inner diameter = 32mm). Depending on actual installation requirements, users can buy suitably sized pipes from their local dealer, from an after-sales service centre or directly off the market.

- 1 Insert the water drain pipe into the unit's water intake connection pipe and use a clamping ring to securely close the insulated water drain pipes.
- 2 Use the water drain pipe insulation to tie the indoor unit's water intake and drain pipes together (particularly for the indoor part) and use water drain pipe cable ties to tie them securely and ensure that the air does not enter and condense.
- 3 In order to prevent water from flowing back into the air conditioner after the operation has been completed, the water drain pipe should be inclined outwards with a slope (drainage part) greater than 1/100. Ensure that the water drain pipe does not bulge or retain water. If it does, then it will be noisy. See "Fig. 27".
- 4 When connecting the water drain pipe, do not pull the intake pipes with force so that the connections do not come loose. At the same time, fit a support bracket every 0.8~1 metres to prevent the water drain pipes from bending. See "Fig. 27".
- 5 When connecting a long water drain pipe, the connections must be covered with insulation to prevent them from coming loose.

6 When the water drain pipe outlet is higher than the water intake pipe connection, try to keep the drain pipe as vertical as possible; the outlet pipe connections will bend so that the height of the drain pipe is 1000 mm from the base of the drain pan. Vice versa, there will be an excessive flow of water at the end of operation. See “Fig. 27”.

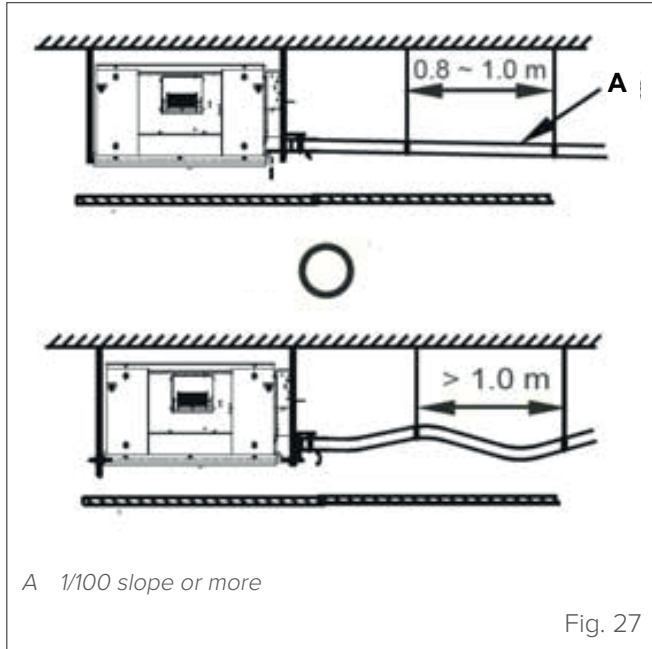

Water drain pipes from multiple units are connected to the main water drain pipe to be discharged through the purification pipe. The drain must have a downward slope of 1/100 or more.

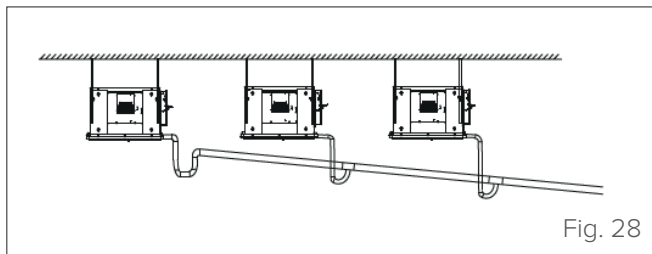

Water drain pipes from multiple units are connected to the main drain pipe that flows into the waste water pipes.

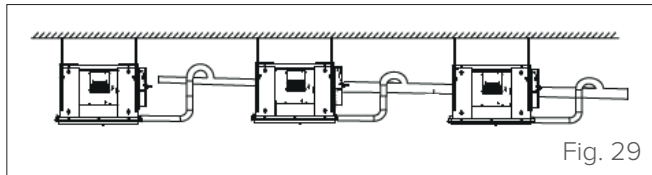

Install the water tank elbow

- For a water drain duct connected to the main drain pan in the indoor unit, the water drain pipe must have a water tank elbow to prevent the loading pressure from increasing during operation of the indoor unit and causing poor water drainage, water leaks or water discharged out of the air outlet duct.
- If the indoor unit operates continuously for long periods (48 hours or more), or when the relative air humidity is 85% or more, connect the water drain pipe as shown in the figure. Install the siphon so that it is easy to clean. Install the water tank elbow, as shown in “Fig. 30”. Install it so that it is easy to clean

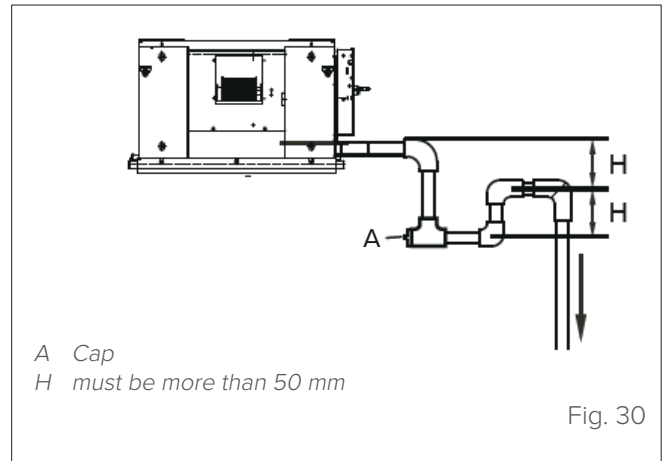

7 The end of the drain pipe must be more than 50 mm off the ground or base of the drain slot. Moreover, do not put the pipe in the water.



WARNING

- When using an extension for the drainage pipe, tighten the connection on the inside with an additional protection pipe to stop it from coming loose.
- The drainage pipe must slope by at least 1/100 to prevent the water from flowing back into the air conditioner.
- To stop the pipe from bending, fix the suspension elements every 1-1.5 m.
- If the drainage pipe outlet is higher than the pump fitting on the unit body, use a lifting pipe for the discharge outlet of the indoor unit. The lifting pipe must be installed no more than 100 cm from the false ceiling and no further than 20 cm from the unit. Incorrect installation can cause the water to flow back into the unit.
- To prevent air bubbles from forming, keep the drainage pipe horizontal or slightly inclined upwards (<75 mm).

CHECK DRAINAGE

Before the test, ensure that the water drain flows smoothly and check that each connection is properly sealed.

Run the water drain test in the new room before completing the ceiling.

Indoor unit without drainage pump

- 1 Use the water intake pipe to supply approximately 2000 ml of water into the drain pan.
- 2 Check that the water drain pipe outlet drains correctly (depending on the length of the pipe, draining can take about one minute), and check near each joint for water leaks.

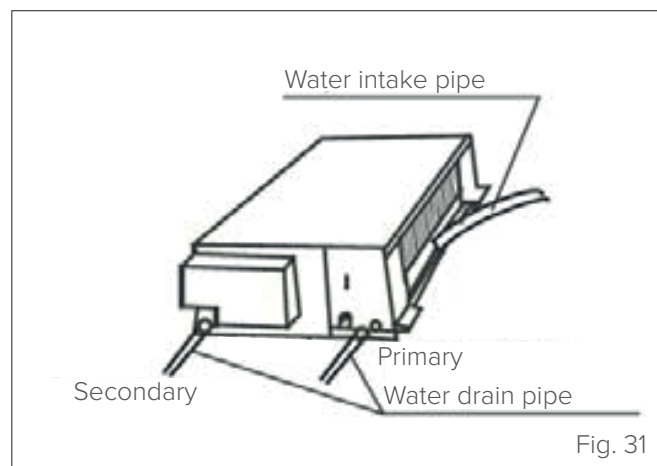

Indoor unit with a drainage pump (optional)

- 1 Use the water intake pipe to supply approximately 2000 ml of water into the drain pan.
- 2 Connect the power supply and set the air conditioner to operate in cooling mode. Check the sound of the drainage pump in operation, and whether the water adequately drains from the discharge water outlet.
- 3 Stop the air conditioner. Wait three minutes, then check for any anomalies. If the water drain pipe diagram is not correct, excessive water flow will result in a water level error and the error code "EE" will be displayed on the screen. Water may overflow from the drain pan.
- 4 Continue adding water until the level is exceeded and the alarm is triggered. Check that the drainage pump drains water immediately. After three minutes, if the water level does not fall below the warning level, the unit will switch off. The power supply must now be switched off and any accumulated water must be drained before the unit can be switched on normally.
- 5 Disconnect the power supply.

3 ELECTRICAL CONNECTIONS

3.1 Preliminary information



ATTENTION ELECTRIC DANGER

- All electrical connections must be done by a licensed electrician according to the provisions of national and local electrical codes.
- Only use copper cables.
- Air conditioners must use a dedicated power supply socket. The power supply voltage must be in line with the rated voltage.
- Electrical wiring must be carried out by a qualified technician and must comply with the circuit diagram labels.
- Before carrying out electrical connections, close the power supply to prevent electric shocks from causing injury.
- The air conditioner’s outdoor power supply must include an earth line, and the earth line of the power cable to the indoor unit must be safely connected to the earth line to the outdoor power supply.
- Differential circuit-breakers must be configured in compliance with the current technical standards and requirements for electrical and electronic devices.
- The connected fixed wiring must be equipped with a differential circuit-breaker with a contact separation distance of at least 3 mm.
- The power cable must be at least 300 mm away from the signalling line in order to prevent electrical interference, malfunctions or damage to electrical components. Similarly, these lines must not come into contact with pipes or valves.
- The electrical wiring must comply with the relevant electrical requirements.
- After completing the wiring and connections and ensuring that they are correct, connect the power supply.



ATTENTION ELECTRIC DANGER

Before making electrical connections, turn off the main switch of the system.

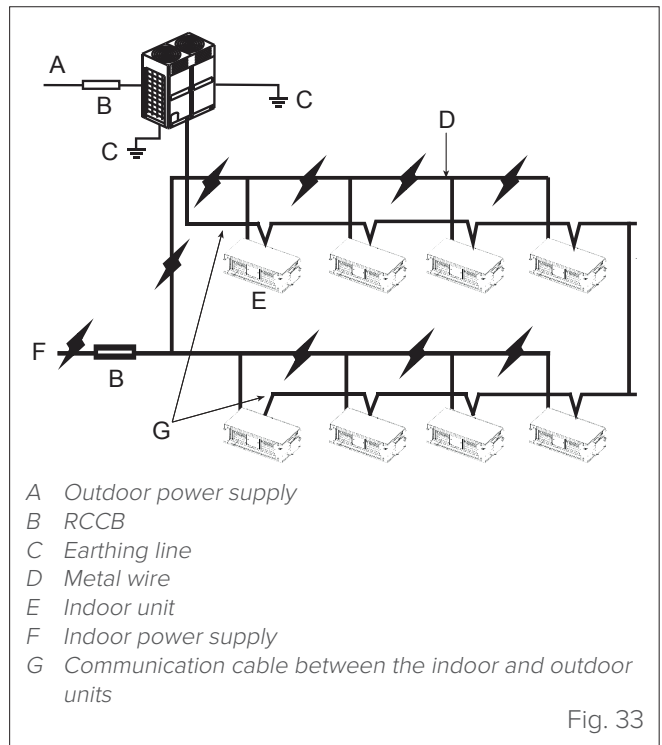

Fig. 33

The specifications for the power cable and communication cable are given below. Wiring with not enough power can cause the electrical wiring to overheat and result in an accident if the unit is damaged.

Model		7.1 ÷ 56.0 kW
Power supply	Phase	1-phase
	Volts and frequency	220-240V-50Hz 220-240V-50/60Hz
Communication cable between the indoor and outdoor units		Shielded 3×AWG16-AWG18
Communication cable between the indoor unit and the wired controller		Shielded AWG16-AWG20
Fuses		15A/30A

3.2 Power cable connection

Use a dedicated power supply to the indoor unit that is different from that to the outdoor unit.
Indoor units connected to the same outdoor unit must be connected to the same power supply, the same circuit breaker and the same differential circuit-breaker.

“Fig. 34” shows the power supply terminal of the indoor unit.

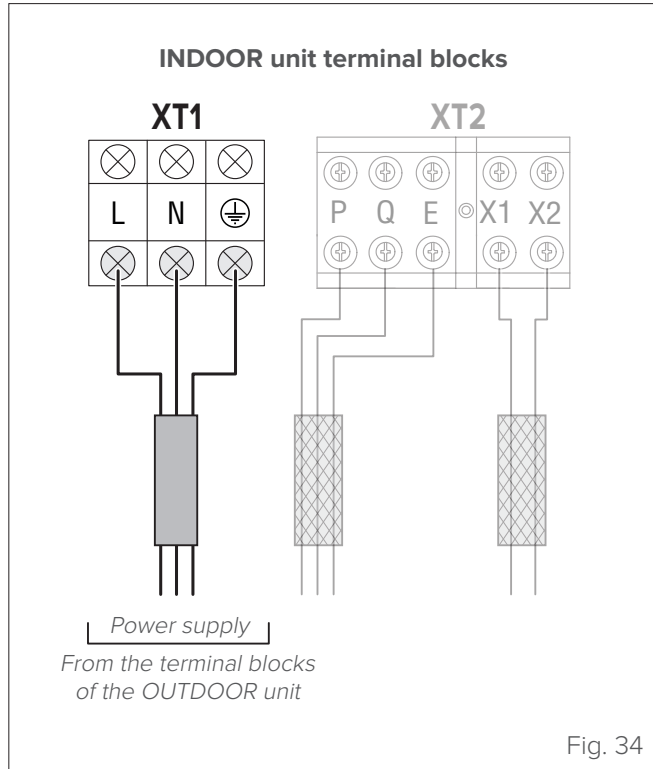

Fig. 34

To connect to the power supply terminal, use the insulated ring terminal “Fig. 35”.

Use a power cable that meets the specifications and securely connect it. To prevent the cable from being pulled from the outside, make sure it is securely fastened.

If the insulated ring terminal cannot be used, make sure you:

- Do not connect two power cables with different diameters to the same terminal (this can cause the cables to overheat due to loose wiring) “Fig. 35”.

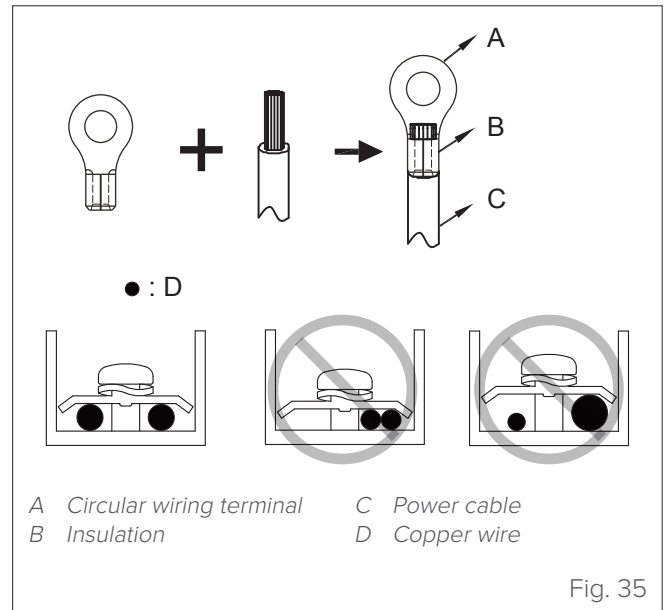

Fig. 35

3.2.1 Electrical wiring specifications

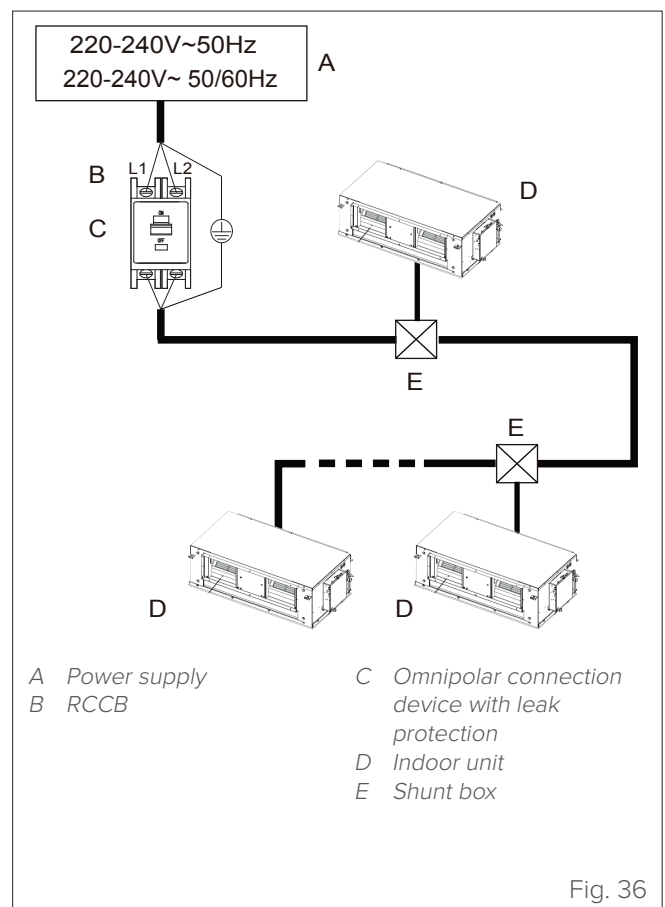

Fig. 36

Electrical connections

Refer to the tables below for power cable specifications.

Electrical characteristics of indoor units

Capacity [kW]	Power supply			IFM		
	Hz	Volts	MCA	MFA	kW	FLA
7.1	50 50/60	220- 240	2.1	15	0.15	1.7
8.0			2.1	15	0.15	1.7
9.0			2.2	15	0.18	1.7
11.2			2.9	15	0.31	2.3
14.0			4.5	15	0.34	3.6
16.0			4.7	15	0.56	3.8
20.0			6.7	15	0.8	5.4
25.0			6.7	15	0.92	5.4
28.0			6.7	15	0.92	5.4
40.0-45.0			12.5	30	1.84	12.4
56.0			15.4	30	1.84	12.4

Abbreviations:

MCA: Minimum circuit Amps

MFA: Maximum fuse Amps

IFM: Indoor unit fan motor

kW: Motor rated power

FLA: Full load Amps

- 1 Select the individual cable diameters (minimum value) for each unit based on the table below:

Rated current of the appliance (A)	Nominal section area (mm ²)	
	Flexible cables	Fixed wiring cable
≤ 3	0.5 < ... ≥ 0.75	1 < ... ≥ 2.5
3 < ... ≥ 6	0.75 < ... ≥ 1	1 < ... ≥ 2.5
6 < ... ≥ 10	1 < ... ≥ 1.5	1 < ... ≥ 2.5
10 < ... ≥ 16	1.5 < ... ≥ 2.5	1.5 < ... ≥ 4
16 < ... ≥ 25	2.5 < ... ≥ 4	2.5 < ... ≥ 6
25 < ... ≥ 32	4 < ... ≥ 6	4 < ... ≥ 10
32 < ... ≥ 50	6 < ... ≥ 10	6 < ... ≥ 16
50 < ... ≥ 63	10 < ... ≥ 16	10 < ... ≥ 25

- 2 The maximum permissible variation of the voltage range between phases is 2%.
- 3 Select a circuit breaker that has a contact separation at all poles of no less than 3 mm that provides full disconnection, where MFA is used to select RCCBs and RCDs



WARNING

Choose the power cable and wiring with reference to the laws and regulations in force. Assign a professional to choose and install the wiring.

3.3 Communication wiring

- Only use shielded cables for communication wiring. Any other type of cable can produce interference between signals, causing the units to malfunction.
- Do not carry out electrical work such as welding with the equipment switched on.
- All shielded wiring in the network is interconnected, and possibly earthed at the same point.
- Do not tie refrigerant pipes, power cables and communication cables together. If the power cable and communication wiring are parallel, the distance between the two lines must be 300 mm or more to prevent signal source interference.
- The communication wiring must not form a closed circuit.

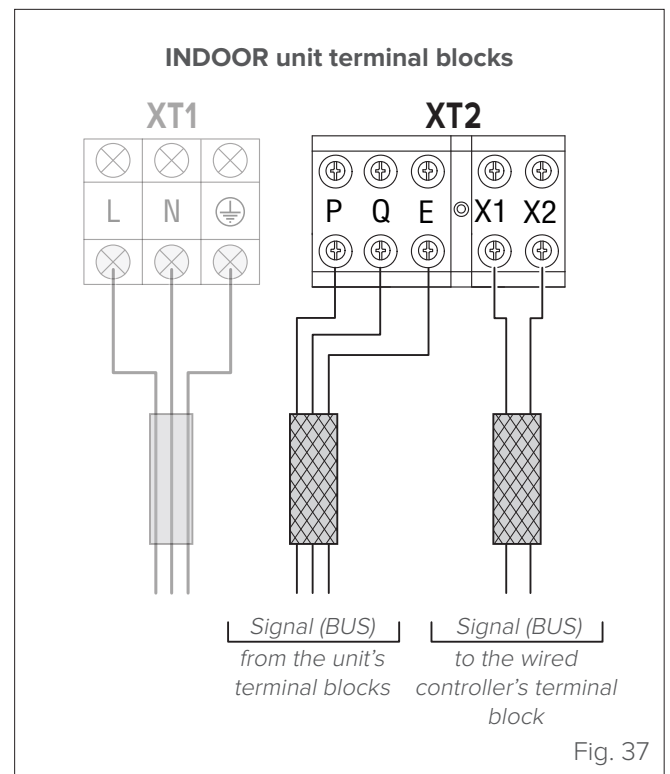

3.3.1 Communication wiring between the indoor and outdoor units

- The indoor and outdoor units communicate via the RS485 serial port.
- Wire the communication bus of the indoor and outdoor units in a daisy-chain configuration from the master outdoor unit to the last indoor unit. The shielding must be connected properly to earth at one point.
- To increase the stability of the communication system, add a resistor to the last indoor unit. See "Fig. 38".
- Do not use star or closed-loop connections because they are incorrect: they cause instability in the communication system and faults in the control system.
- Use a three-pole shielded cable (0.75 mm² or more) for the communication wiring between the indoor and outdoor units. Ensure that the wiring is connected properly. The connection for this communication cable must come from the main outdoor unit.
- Install a 120 Ohm termination heater between terminals P-Q of the last indoor unit.

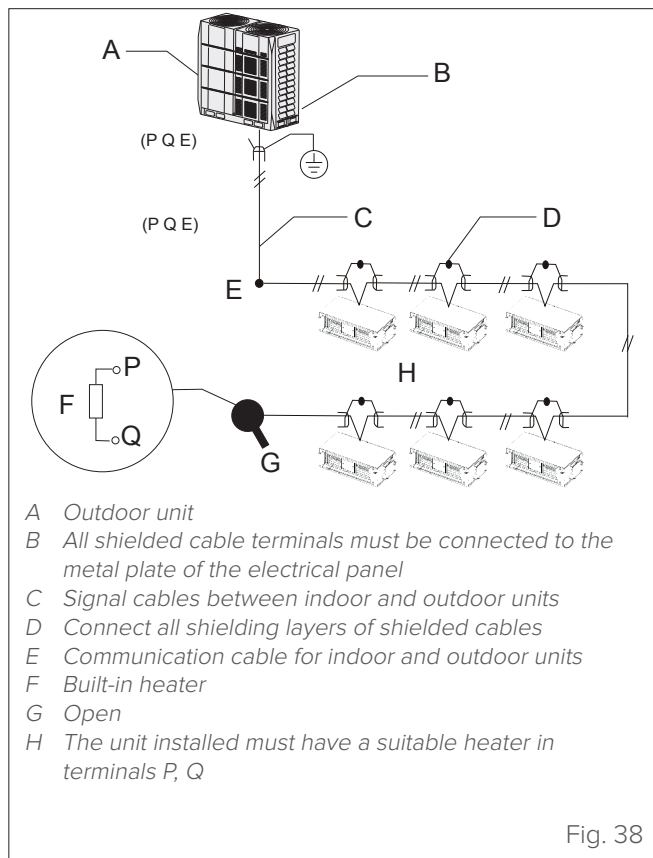

Fig. 38

3.3.2 Communication wiring between the indoor unit and the wired controller

The wired controller and the indoor unit can be connected in different ways, depending on the forms of communication.

1 For a two-way communication mode:

- Use 1 wired controller or 2 wired controllers (one main and one secondary) to control 1 indoor unit (See "Fig. 38");

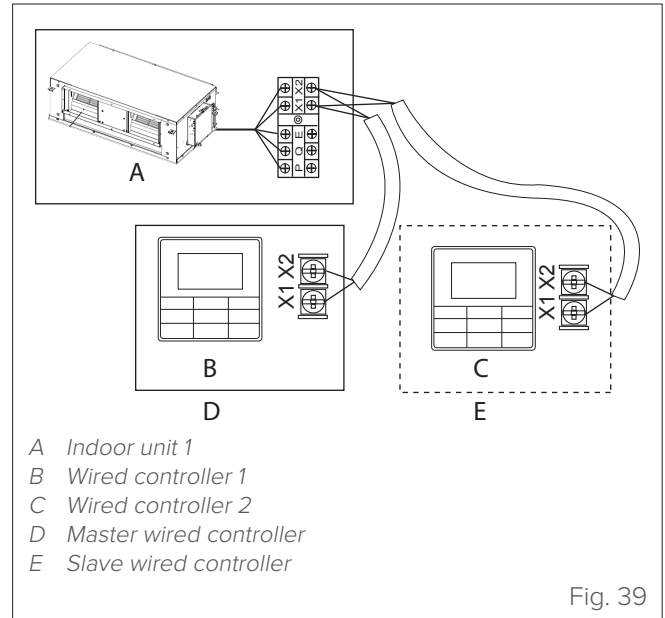

Fig. 39

- Use 1 wired controller or 2 wired controllers (one main and one secondary) to control multiple indoor units (See "Fig. 40");

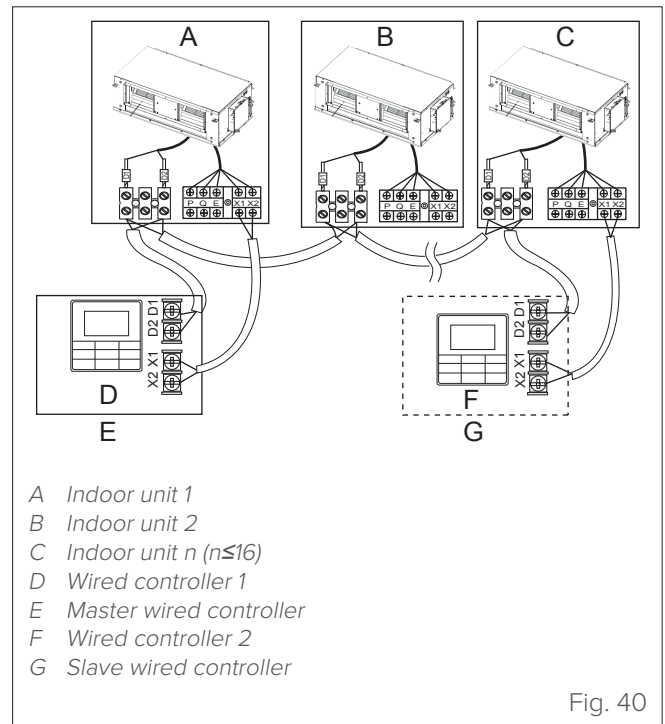
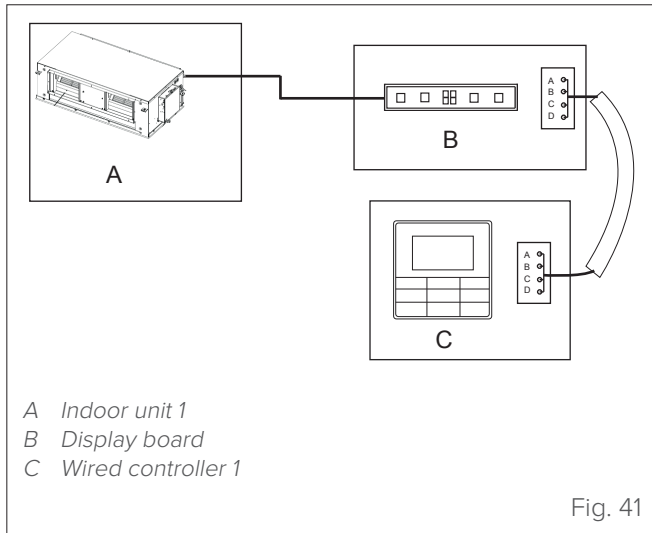

Fig. 40

2 For a one-way communication mode

- Use 1 wired controller to control 1 indoor unit (See “Fig. 41”).



- Once the wiring has been laid and the connections have been made, fasten and secure the wiring properly to prevent an external force from pulling on the connection point.
- Keep the wiring straight so that there are no differences in height that prevent the electrical panel cover from being closed tightly.
- Use professional insulating and sealing materials to seal and protect perforated cables. Inadequate sealing can lead to condensation and encourage the entry of small animals or insects which can cause short circuits in parts of the electrical system, thereby causing a fault.

- For connection, refer to the wiring and connection instructions in the wired controller manual.
- Ports X1/X2, D1/D2 on either side of the main control board and the one-way communication port (display board side) are for different types of wired controller (See “Fig. 42”).
- Use the connection cables (accessory) to connect ports D1/D2.

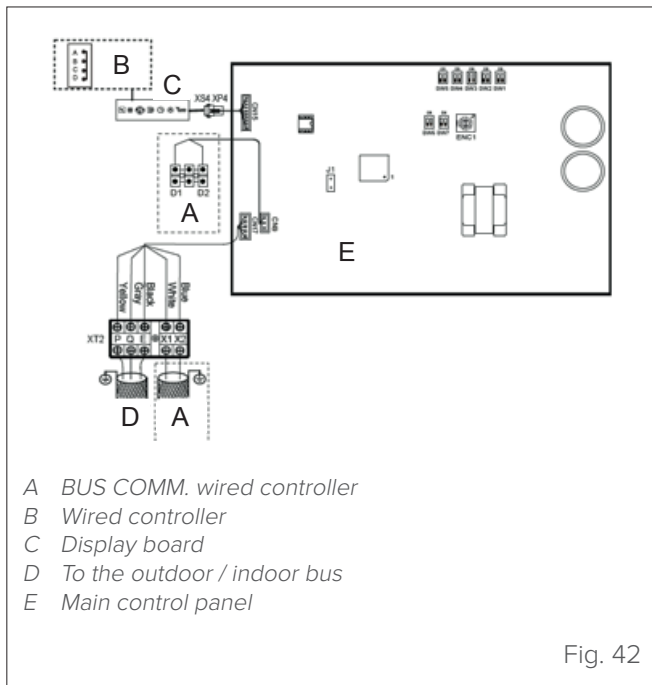

4 CONFIGURATION

4.1 Power setting

Set the board's DIP switch on the internal electrical panel for different applications. Once it has been set, disconnect the main power switch and then reconnect it. If the main switch is not disconnected and then reconnected, the setting will not be applied.

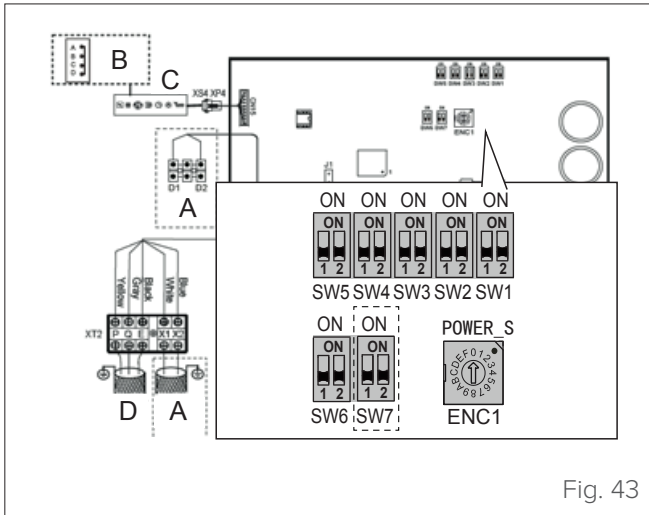
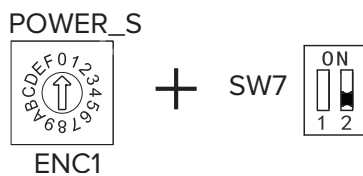

Fig. 43

Key	
	Dip-switch ON (1)
	Dip-switch OFF (0)



ENC1 Power DIP Switch settings:

POWER_S ENC1	
Toggle switch	Set cooling capacity
Dial code	Cooling capacity
0	2200 W (*)
1	2800 W (*)
2	3600 W (*)
3	4500 W (*)
4	5600 W (*)
5	7100 W
6	8000 W
7	9000 W
8	10000 W (*)
9	11200 W
A	12500 W (*)
B	14000 W
C	16000 W
D	18000W (*)
E	20000W
F	25000W

(*) Reserved

POWER_S ENC1	
Toggle switch	Set cooling capacity
Dial code	Cooling capacity
0	28000 W
1	33500 W (*)
2	40000 W
3	45000 W
4	56000 W

(*) Reserved



WARNING

The power DIP switches have been configured before delivery. These settings must only be changed by qualified maintenance personnel.

4.2 Address setting

When the indoor unit is connected to the outdoor unit, the outdoor unit will automatically distribute the address to the indoor unit. Or the controller can be used to set the address manually.

- Indoor units can have the same address in the same system.
- The network address and the indoor unit address are the same and do not have to be configured separately.
- Once the address settings have been completed, mark the address on each indoor unit to facilitate after-sales maintenance.
- The centralised controller for the indoor unit is completed on the outdoor unit. For further details, refer to the outdoor unit manual.



CAUTION

Once the indoor unit has completed the centralised control function on the outdoor unit, the DIP switch on the main control panel of the outdoor unit must be set to auto-addressing; otherwise the indoor units in the system are not controlled by the centralised controller.

- The system can connect up to 64 indoor units (0~63 addresses) simultaneously. Units with the same address can cause a malfunction

4.3 DIP Switch settings on main board





SW1_1	
	Cooling mode temperature compensation: 0°C
	Cooling mode temperature compensation: 2°C





SW1_2	
	EEV in position 96 (step) waiting in heating mode
	EEV in position 72 (step) waiting in heating mode





SW2	
	External static pressure 1
	External static pressure 2
	External static pressure 3
	External static pressure 4

SW3_1	
	Reserved
	Indoor unit address deletion

SW3_2	
	Reserved



SW4	
 [00]	When the set temperature is reached in heating mode, the fan operates on a 4-minute off / 1-minute on cycle.
 [01]	When the set temperature is reached in heating mode, the fan operates on an 8-minute off / 1-minute on cycle.
 [10]	When the set temperature is reached in heating mode, the fan operates on a 12-minute off / 1-minute on cycle.
 [11]	When the set temperature is reached in heating mode, the fan operates on a 16-minute off / 1-minute on cycle.



SW5	
 [00]	In heating mode, the fan does not operate when the temperature midpoint of the internal heat exchanger is 15°C or lower.
 [01]	In heating mode, the fan does not operate when the temperature midpoint of the internal heat exchanger is 20°C or lower.
 [10]	In heating mode, the fan does not operate when the temperature midpoint of the internal heat exchanger is 24°C or lower.
 [11]	In heating mode, the fan does not operate when the temperature midpoint of the internal heat exchanger is 26°C or lower.

SW6	
 [00]	Heating mode temperature compensation: 6°C
 [01]	Heating mode temperature compensation: 2°C
 [10]	Heating mode temperature compensation: 4°C
 [11]	Heating mode temperature compensation: 0°C

SW7	
 [00]	Reserved

SW7_1	
 [0_]	Reserved

SW7_2	
 [_0]	Unit with < 28 kW capacity
 [_1]	Unit with ≥ 28 kW capacity

J1	
	Automatic restart function enabled
	Automatic restart function disabled



CAUTION
All DIP switches (including power DIP switches) have been configured before delivery. These settings should only be changed by qualified maintenance personnel.

An incorrect setting of the DIP switch can cause condensation, noise or unexpected system malfunction.

5 RUNNING THE TEST

5.1 Checks to perform before running the test

- Indoor and outdoor units properly installed;
- Correct pipes and wiring;
- No seepage from the refrigerant piping system;
- Correct water drain;
- Full insulation;
- Earth connection correctly connected;
- Piping length adjusted and refrigerant filled up;
- Power supply voltage corresponding to the rated voltage of the air conditioner;
- The inlets and outlets of the indoor and outdoor units are not obstructed;
- The gas and liquid taps of the outdoor unit are open;

When the remote/wired controller is used to set air conditioner cooling, check the following points one by one. In case of fault, refer to troubleshooting in the manual.

5.2 Running the test

- The remote/wired controller function buttons work properly;
- Room temperature control is normal;
- The LED indicator is on;
- Water drainage is normal;

No vibrations or noise during operation

Note: Once the power supply is connected, when the unit is switched on or started immediately after the unit is switched off, the air conditioner uses a protective function that delays compressor start-up

6 USE

6.1 Description of system components

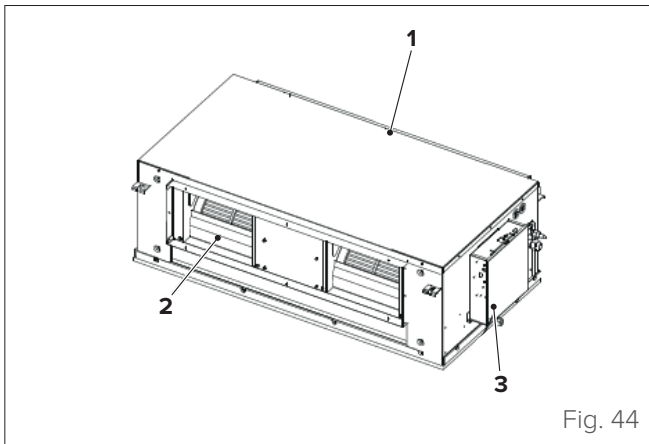

Fig. 44

- 1 Air inlet
- 2 Air outlet
- 3 Electrical panel



WARNING

The images in this manual are provided for illustrative purposes only. The appearance of your appliance may differ slightly from the illustrations shown here. Refer to the actual characteristics of the unit.



CAUTION DANGER

- If an abnormal condition occurs (e.g. there is a smell of burning), turn the unit off immediately and ask the dealer for assistance to avoid the risk of injury, fire or electrocution.
- DO NOT allow the indoor unit or the remote control to get wet. Humidity can cause an electric shock or a fire risk.
- DO NOT insert fingers, bars or other objects into the air inlet or outlet openings. These operations can be dangerous because the fan can rotate at high speed.
- DO NOT use flammable sprays, such as hairspray or paint, near the unit. These materials can cause fire or combustion.



WARNING

- DO NOT touch the air outlet while the flaps are swinging. Fingers can get trapped or the unit can break down.
- To prevent the appliance from deteriorating, do not use the air conditioner for preservation purposes (food, plants, animals, works of art, etc.).
- DO NOT touch the indoor unit's evaporator coils. The evaporator coils are sharp and can cause personal injury.
- DO NOT place objects that are not resistant to humidity under the indoor unit. A relative humidity of 80% can cause condensate to form.
- DO NOT expose heat generating appliances to cold air and do not place them under the indoor unit. The airflow can cause incomplete combustion, while the heat can cause the unit to deform.
- After long periods of use, check the indoor unit to make sure that it is not damaged. Damage can cause the indoor unit to fall and cause personal injury.
- If the air conditioner is used at the same time as other heating devices, the room must be aired properly to avoid oxygen deficiencies.
- DO NOT use the air conditioner if an insecticidal fumigant is used in the room. The chemicals can be absorbed by the unit and create dangerous situations for people who are hypersensitive to those substances.

6.2 Manual operation (without remote control)

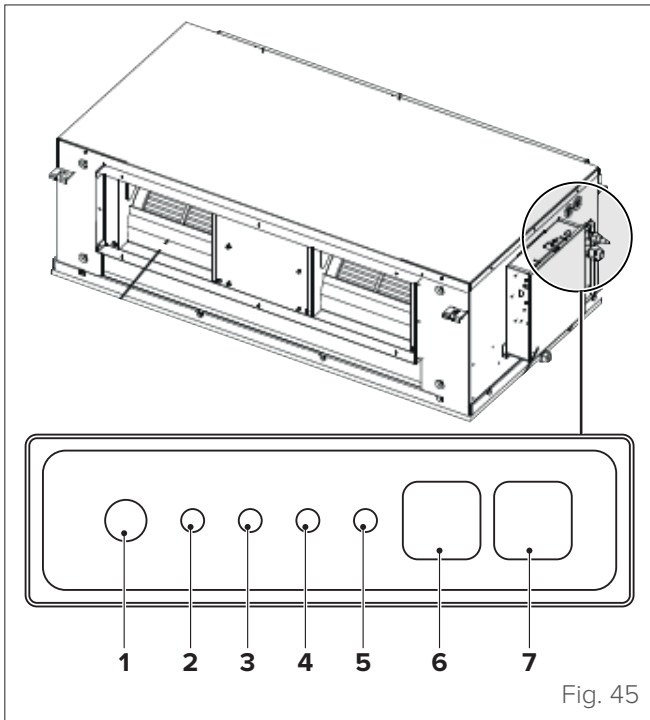

Fig. 45

- 1 Manual button
- 2 Operation indicator
- 3 Timer light
- 4 PRE-DEF indicator (preheating/defrosting)
- 5 Alarm indicator
- 6 Infrared receiver
- 7 LED display (shows the temperature set or the error codes if an alarm is triggered)
 - **MANUAL button:** This button is used to select the operating mode in the following order: AUTO, FORCED COOL, OFF.
 - **Forced Cooling Mode:** In FORCED COOL mode, the operation light flashes. The system operates with the fan at high speed for 30 minutes, then switches to AUTO mode. During this operating cycle, the remote control is disabled.

The operating temperature range:

	Cooling Mode	Heating Mode
Room temperature	17°C ÷ 32°C	≤ 27°C
Ambient humidity	≤ 80% (*)	

(*) Condensate forms on the surface of the unit and water drips out of the unit when the indoor humidity is higher than 80%

6.3 Other functions

– Automatic restart

If the power supply to the unit is interrupted, the unit will automatically restart with the last settings when it is restored.

– Detection of refrigerant leaks

The indoor unit automatically displays “EC” when it detects a refrigerant leak.

6.4 Airflow angle control

As hot air rises and cold air falls, the distribution of heated/cooled air in a closed room can be improved by positioning the unit’s louvers.

The angle of the louver can be adjusted by pressing the [SWING] button on the remote control.



WARNING

- During the heating phase, the horizontal air flow will enhance the uneven distribution of the room temperature.
- In Cooling mode, do not leave the direction of the louver at an angle that is too vertical for a prolonged period. In this position condensate may form on the louver, which may then fall on the floor and furniture.

Auto-swing

Press SWING to continuously swing the louvers up and down.

Manual swing

Adjust the louvers to enhance the hot or cold effect.

During cooling, adjust the ventilation louvers horizontally.

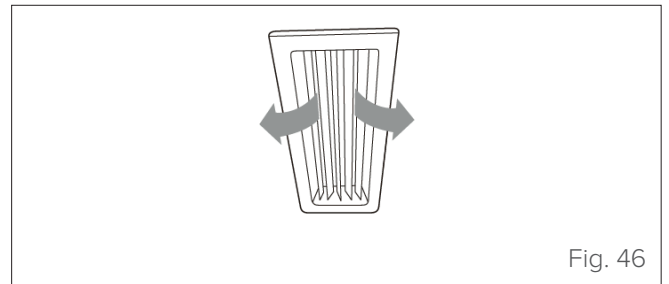

Fig. 46

During heating, adjust the ventilation louvers downwards.

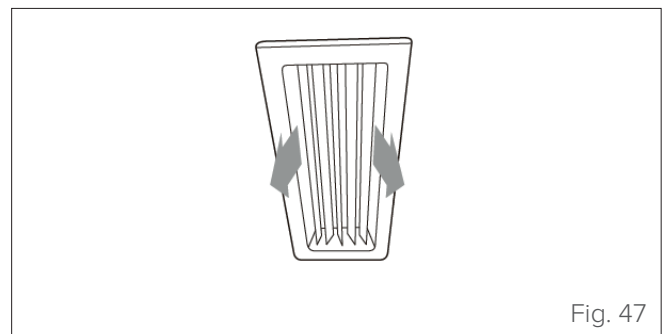

Fig. 47

7 MAINTENANCE

It is good practice to periodically clean both the internal and external parts of the appliance. This guarantees its proper operation and durability.

Carry out periodic maintenance of the appliance in accordance with the regulations in force.

Maintenance must be carried out by qualified technical personnel.

Improper maintenance or service can cause electric shock, fire or water leakage.

7.1 Cleaning the indoor unit



ATTENTION ELECTRIC DANGER

- Before cleaning or maintenance, always switch off the air conditioner and disconnect it from the power supply.
- DO NOT replace blown fuses with fuses of different amps because this could damage the circuit or cause a fire hazard.
- Check that all cables are connected correctly. Incorrectly connecting cables can create a fire or electrocution risk.



CAUTION

- Use only a soft, dry cloth to clean the unit. If the unit is particularly dirty, you can use a cloth moistened in warm water.
- Check that the drain pipe is installed according to the instructions. If it is not, water leaks may occur resulting in material damage and fire and electrocution risks.



IT IS PROHIBITED TO

- use chemicals or chemically treated cloths to clean the unit;
- use benzene, thinners, polishing powders or other solvents to clean the unit. These substances can cause cracking or deformation of the plastic surface;
- use water at temperatures above 40°C to clean the front panel. Very hot water can cause the panel to deform or discolour.

7.2 Cleaning the air filter

The filter stops dust and other particles from entering the indoor unit. A build-up of dust can reduce the efficiency of the air conditioner. For optimal efficiency, clean the air filter every two weeks or, if the zone is very dusty, more frequently. If the filter is very clogged and cannot be perfectly cleaned, it is advisable to replace it.



WARNING

It can be dangerous to remove and clean the filter. Disassembly and maintenance operations must be carried out by certified technical personnel.



CAUTION DANGER

When removing the filter, avoid touching the metal parts of the unit. Sharp metal edges can be sharp.



IT IS PROHIBITED TO

dry the filter by exposing it to direct sunlight. The filter may shrink

- 1 Unlock the grille by pushing the two catches towards the centre at the same time.
- 2 Detach the grille from the main unit by tilting it 45°, lifting it slightly and then pulling it forward.

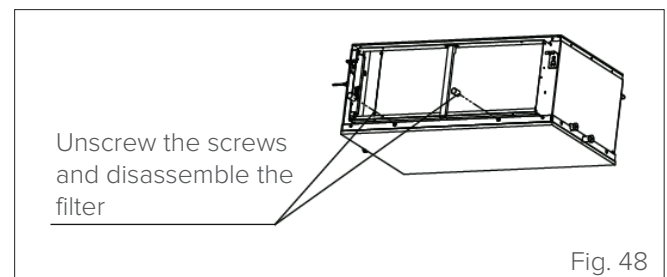

Fig. 48

- 3 Remove the air filter.

- 4 Clean the air filter with a vacuum cleaner or wash it with warm water and a mild detergent.
 - If you use a vacuum cleaner, put the inlet side facing the vacuum cleaner.

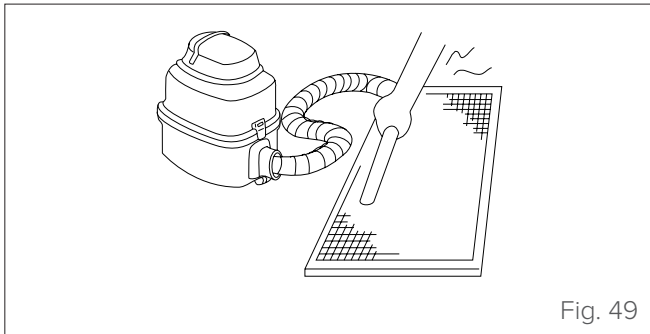

Fig. 49

- If you use water, the inlet side must face downwards, in the opposite direction to the water flow.

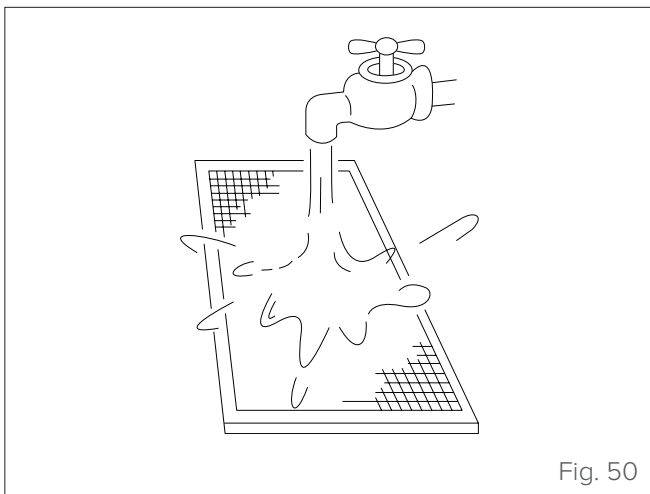
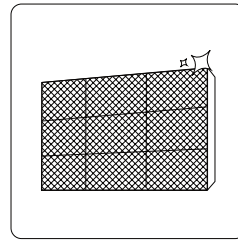

Fig. 50

- 5 Rinse the filter with clean water and let it dry in a cool, dry place, away from direct sunlight.
- 6 Once dry, reinsert the filter into the indoor unit.
- 7 Refit the front grille and reconnect the display cable to the electrical panel on the main body.

7.3 Extended periods of inactivity

If you do not plan to use the air conditioner for an extended period of time, proceed as follows:



Clean all filters

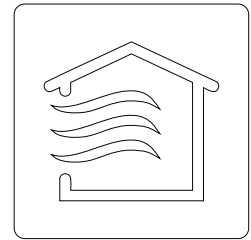

Activate the Ventilation mode until the unit is completely dry (at least 12 hours)

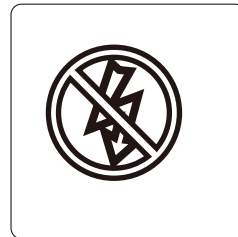

Switch the unit off and disconnect it from the mains power supply

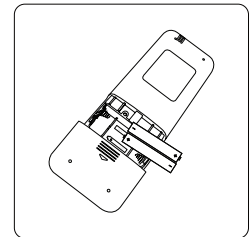

Remove the batteries from the remote control

7.4 Maintenance at the start of the season

After a long period of non-use, or before a period of frequent use, proceed as follows:

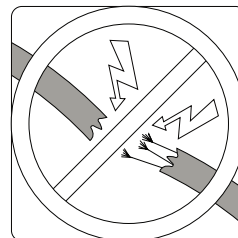

Check that the cables are intact

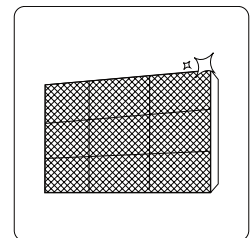

Clean all filters



Check that there are no leaks

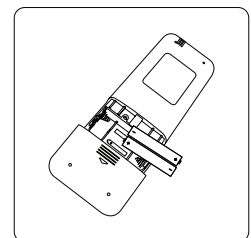

Replace batteries

Remove all obstacles that could block the openings of the indoor and outdoor units.

Clean the air filter and the front grille of the indoor unit. Refit the clean and dry air filter in its original position.

Turn the main power switch on at least 12 hours before switching the unit on.

7.5 Troubleshooting



CAUTION DANGER

If any of the following conditions occur, switch the unit off immediately.

- The power cable is damaged or unusually hot.
- You can smell burning.
- The unit makes loud or abnormal noises.
- A fuse blows or the circuit breaker trips frequently.
- Water or other substance have fallen into the unit, or water or other substance have leaked from the unit.

DON'T TRY TO SOLVE THE PROBLEM YOURSELF. IMMEDIATELY CONTACT AN AUTHORISED SERVICE CENTRE.

7.5.1 Common problems

The problems described below do not represent malfunctions and, in most cases, do not require repair.

Problem	Possible causes
The unit does not switch on when the ON/OFF button is pressed	<ul style="list-style-type: none"> - In order to protect some of the system's components, the system intentionally starts or restarts with a delay of up to 12 minutes under certain operating conditions. If the OPERATION LED lights up on the unit's panel, the system will operate normally and the unit will start after the intentional delay has finished. - The heating mode works, if the "DEF./FAN" LED lights on the panel are on, the indoor unit activates protective measures due to low leaving temperature.
The indoor unit emits a white haze	- In humid regions, a marked difference in temperature between the air in the room and the air conditioning can cause a white mist to form. The phenomenon ceases when the humidity in the room is restored to normal levels.
Both the indoor and outdoor units emit a white haze	- When the unit restarts in Heating mode after a defrosting cycle, it may emit a white haze due to moisture generated by the defrosting process.
Indoor or outdoor unit emits dust	- During a long period of non-use, dust may accumulate on the unit and be emitted when it is turned on again. This problem can be partly solved by covering the unit during prolonged periods of inactivity.
The unit smells bad	<ul style="list-style-type: none"> - The unit may absorb ambient odours (furniture, cooking, cigarettes, etc.) and emit them during operation. - Mold has formed on the unit's filters and must be removed.
Operation is erratic or unpredictable, or the unit does not respond to commands	<p>Interference from mobile phone repeaters and remote amplifiers may cause the unit to malfunction.</p> <p>In this case, try to solve the problem as follows:</p> <ul style="list-style-type: none"> - Disconnect the unit from the power mains and then reconnect it. - Press the ON/OFF button on the remote control to restart operation.

NOTE: if the problem persists, contact your local dealer or nearest service centre, providing a detailed description of the malfunction and specifying the model code.

7.5.2 Anomalies and remedies

If problems occur, please check the following before contacting a service centre.

Anomalies	Possible causes	Remedies
Unsatisfactory cooling performance	The set temperature may be higher than the room temperature	Set a lower temperature
	The heat exchanger of the indoor or outdoor unit is dirty	Clean the heat exchanger (Service Centre)
	The air filter is dirty	Remove the filter and clean it following instructions
	The air inlet or outlet of the indoor or outdoor unit is blocked	Switch the unit off, remove the cause of the obstruction and switch the air conditioner on again
	Open doors and windows	Close doors and windows when using the unit
	Sunlight produces excessive heat	Close curtains and windows during the hottest hours or when the sun is brightest
	Too many heat sources in the room (people, computers, electronic devices, etc.)	Reduce heat sources
	Low refrigerant level due to leakage or prolonged use	Check for leaks, reseal the system if necessary and refill the refrigerant (Service Centre)
The unit does not work	Power failure	Wait for power to be restored
	The power supply switch is off	Unit's power supply. This indoor unit is part of an air conditioning system that has multiple indoor units all connected. The indoor units cannot be powered individually - they are all connected to the same switch.
	The fuse is blown	Replace the fuse (Service Centre)
	Remote control batteries are low	Replace batteries
The unit starts or stops frequently	The amount of refrigerant in the system is excessive or insufficient	Check for leaks and top up the refrigerant (Service Centre)
	Incompressible gas has entered or moisture has penetrated the system.	Evacuate the system and recharge the refrigerant (Service Centre)
	The compressor is faulty	Replace the compressor (Service Centre)
	The voltage is too high or too low	Install a voltage controller (Service Centre)
Unsatisfactory heating performance	Cold air enters through doors and windows	Close doors and windows when using the unit
	Low refrigerant level due to leakage or prolonged use	Check for leaks, reseal the system if necessary and refill the refrigerant (Service Centre)
The indicator lights continue to flash	The unit may stop or continue to operate properly. If the indicator lights continue to flash or error codes are displayed, wait approximately 10 minutes. The problem may solve itself. If not, disconnect the unit from the power mains and reconnect it. Switch on the unit. If the problem persists, disconnect the unit from the power supply and contact the nearest service centre.	
An error code appears on the display of the indoor unit: • E0, E1, E2... • P1, P2, P3... • F1, F2, F3...		

NOTE: if, after performing the above checks and diagnostic procedures, the problem persists, switch the unit off immediately and contact an authorised service centre.

7.6 Indoor unit error codes

Error code	Description	Possible causes
E0	Mode conflict	<ul style="list-style-type: none"> – The operating mode of the indoor unit clashes with that of the outdoor units.
E1	Communication error between indoor and outdoor units	<ul style="list-style-type: none"> – Communication cables between indoor and outdoor units are not connected properly. – Interference from high voltage wires or other sources of electromagnetic radiation. – Communication cable too long. – Main PCB is damaged.
E2	Internal air temperature sensor error (T1)	<ul style="list-style-type: none"> – Temperature sensor not connected properly or has malfunctioned. – Main PCB is damaged.
E3	Internal heat exchanger temperature midpoint sensor error (T2)	
E4	Internal heat exchanger leaving temperature sensor error (T2B)	
E6	Fan error	<ul style="list-style-type: none"> – Fan jammed or obstructed. – Fan motor not connected properly or has malfunctioned. – Power supply abnormal. – Main PCB is damaged.
E7	EEPROM error	
Eb	Internal EEV coil error	<ul style="list-style-type: none"> – Loose or broken line. – The electronic expansion valve has jammed. – Main PCB is damaged.
Ed	Outdoor unit faulty	<ul style="list-style-type: none"> – Outdoor unit error.
EE	Water level alarm malfunction	<ul style="list-style-type: none"> – The water level float is stuck. – The water level switch is not connected correctly. – Main PCB is damaged. – The drain pump has malfunctioned.
FE	No address assigned to the indoor unit	<ul style="list-style-type: none"> – No address assigned to the indoor unit.
A1 *	Refrigerant leak	
A0 *	Emergency stop	
F7+ repeated address *	Multiple indoor units with the same address	
U4 *	MS box self-diagnosis error	
F8 *	MS box error	

NOTES:

(*) only for V6R systems

Fast flash = 0.5 s

Slow flash = 1 s

8 DISPOSAL

The manufacturer is registered on the National EEE Register, in compliance with implementation of Directive 2012/19/EU and pertinent national regulations on electrical and electronic equipment waste.

This Directive requires electrical and electronic equipment to be disposed of properly.

Equipment bearing the crossed-out wheelee bin symbol must be disposed of separately at the end of its lifecycle to prevent damage to human health and to the environment.

Electrical and electronic equipment must be disposed of together with all of its parts.

To dispose of “household” electrical and electronic equipment, the manufacturer recommends contacting an authorised dealer or an authorised ecological site.

“Professional” electrical and electronic equipment must be disposed of by authorised personnel through established waste disposal authorities around the country.

In this regard, here is the definition of household WEEE and professional WEEE.

WEEE from private households: WEEE originating from private households and WEEE which comes from commercial, industrial, institutional and other sources which, because of its nature and quantity, is similar to that from private households. Subject to the nature and quantity, where the waste from EEE was likely to have been used by both a private household and users of other than private households, it will be classed as private household WEEE;

Professional WEEE: all WEEE which comes from something other than private households.

This equipment may contain:

- refrigerant gas, the entire contents of which must be recovered in suitable containers by specialised personnel with the necessary qualifications;
- lubrication oil contained in compressors and in the refrigeration circuit to be collected;
- mixtures with antifreeze in the water circuit, the contents of which are to be collected;
- mechanical and electrical parts to be separated and disposed of as authorised.

When the components to be replaced for maintenance purposes are removed or when the entire unit reaches the end of its life and needs to be removed from the installation, waste should be separated by its nature and disposed of by authorised personnel at existing collection centres.



9 ATTACHMENTS

9.1 Indoor unit wiring diagrams

Series	Size
CN-2-XMi	D71 ÷ D80

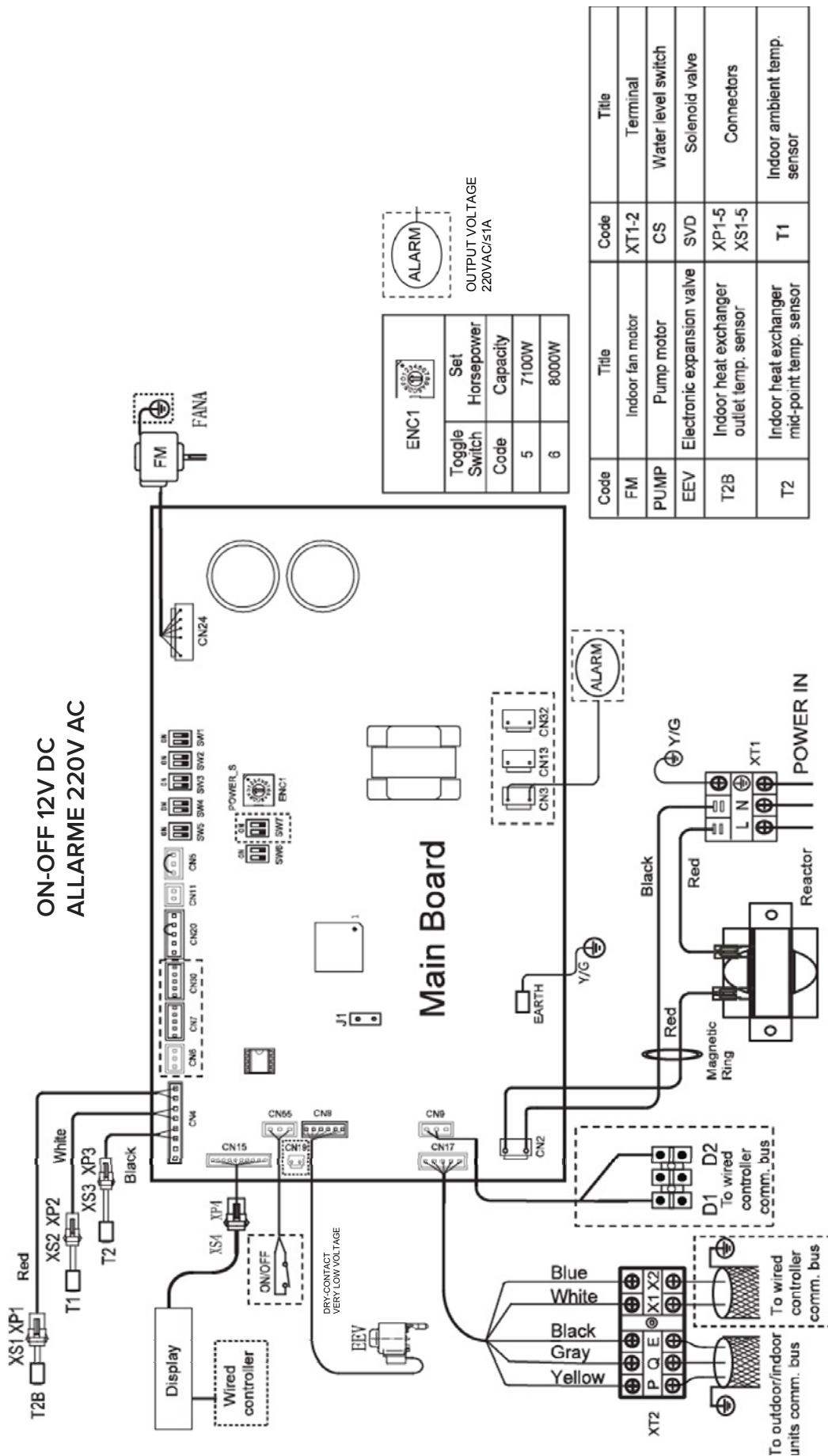

Series	Size
CN-2-XMI	D90 ÷ D160

ON-OFF 12V DC
ALLARME 220V AC

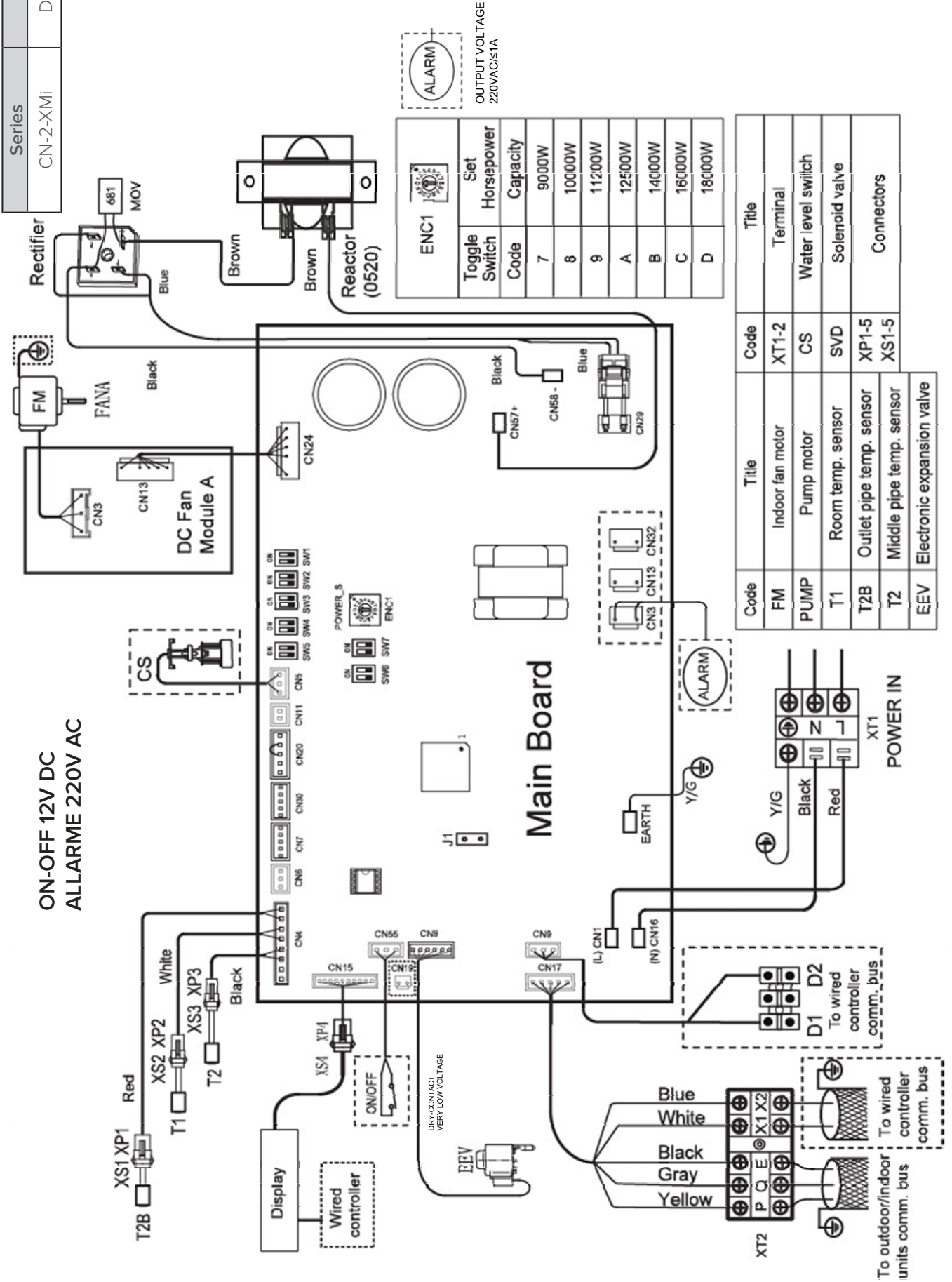

Series	Size
CN-2-XMI	D250 ÷ D280

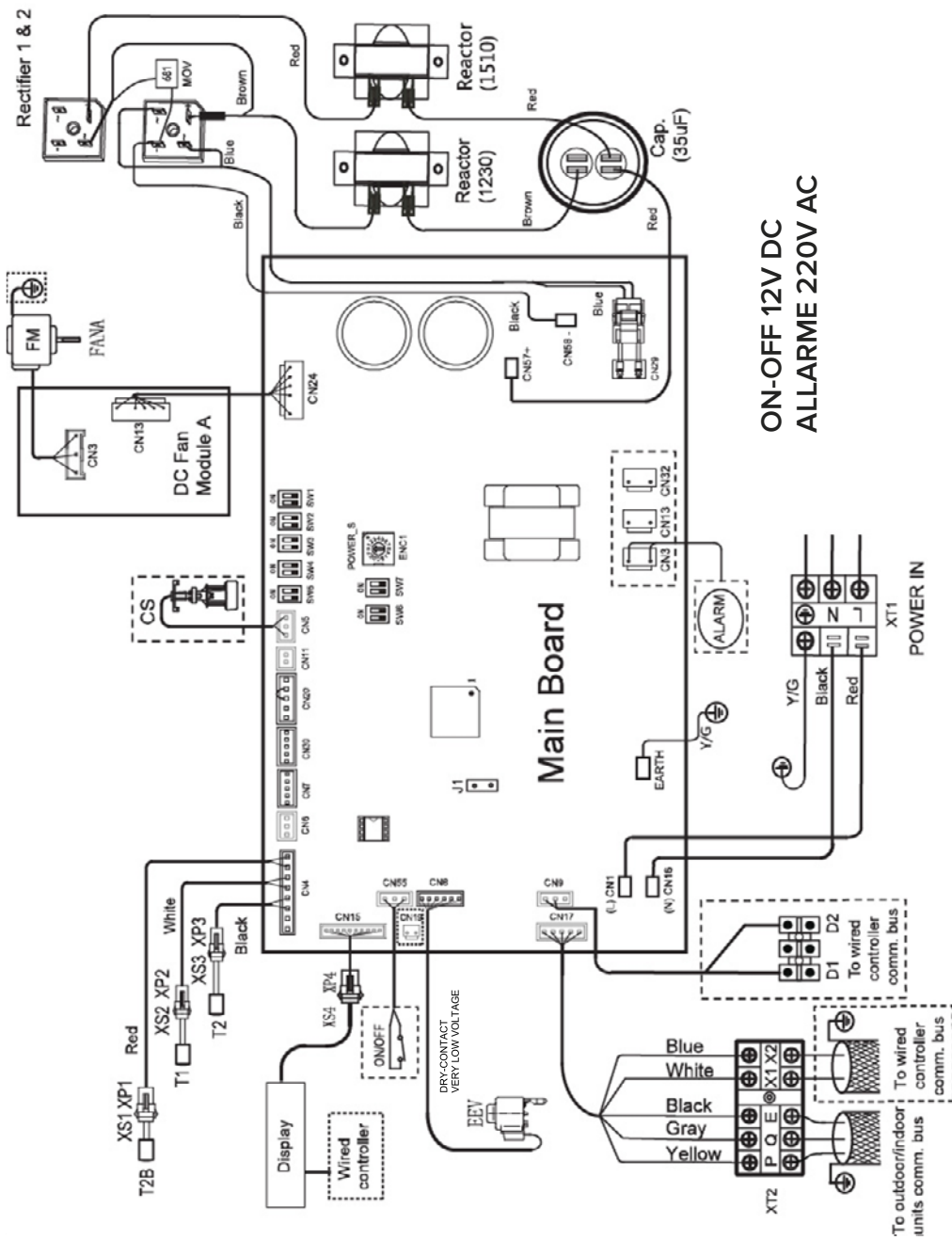

ENC1	SW7	ON	+	[0]	ENC1	SW7	ON	+	[1]
Toggle Switch	Set Horsepower	Code	Capacity	20000W	Toggle Switch	Set Horsepower	Code	Capacity	28000W
E					F				

Code	Title
FM	Indoor fan motor
PUMP	Pump motor
T1	Room temp. sensor
T2B	Outlet pipe temp. sensor
T2	Middle pipe temp. sensor
EEV	Electronic expansion valve
XT1-2	Terminal
CS	Water level switch
XP1-5	Connectors
XS1-5	Connectors
SVD	Scienoid valve

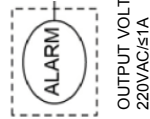

OUTPUT VOLTAGE
220VAC/5/1A

ON-OFF 12V DC
ALLARME 220V AC

POWER IN

To outdoor/indoor units comm. bus

To wired controller comm. bus

Series	Size
CN-2-XMI	D400 - D450 - D560

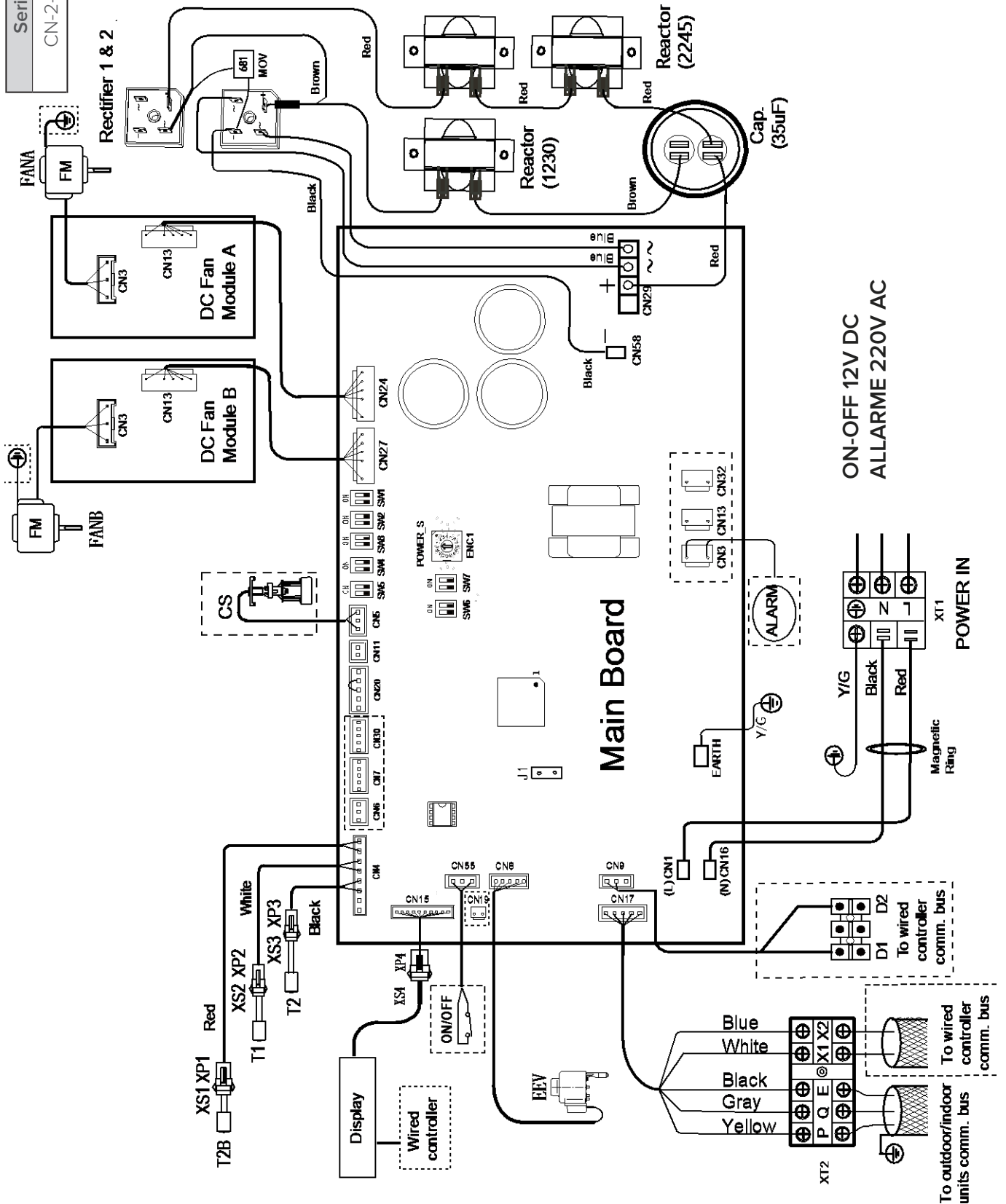

9.2 Declaration of conformity



DECLARATION OF CONFORMITY UE

DICHIARAZIONE DI CONFORMITÀ EU
KONFORMITÄTSEKTLÄRUNG UE
DECLARATION DE CONFORMITE UE
DECLARACIÓN DE CONFORMIDAD UE

WE DECLARE UNDER OUR SOLE RESPONSIBILITY THAT THE MACHINE

DICHIARIAMO SOTTO LA NOSTRA SOLA RESPONSABILITÀ CHE LA MACCHINA
WIR ERKLÄREN EIGENVERANTWORTLICH, DASS DIE MASCHINE
NOUS DÉCLARONS SOUS NOTRE SEULE RESPONSABILITÉ QUE LA MACHINE
EL FABRICANTE DECLARA BAJO SU EXCLUSIVA RESPONSABILIDAD QUE LA MÁQUINA

CATEGORY DIRECT EXPANSION TERMINALS - Heat pump
CATEGORIA TERMINALI AD ESPANSIONE DIRETTA - Pompa di calore
KATEGORIE DIREKTVERDAMPFUNGSGERÄTE - Wärmepumpe
CATEGORIE TERMINAUX À DÉTENTE DIRECTE - Pompe à chaleur
CATEGORIA TERMINALES POR EXPANSIÓN DIRECTA - Bomba de calor

TYPE / TIPO / TYP / TYPE / TIPO

MODEL	MODEL
CN-2-XMi D71	CN-2-XMi D160
CN-2-XMi D80	CN-2-XMi D200
CN-2-XMi D90	CN-2-XMi D250
CN-2-XMi D112	CN-2-XMi D280
CN-2-XMi D140	

- COMPLIES WITH THE FOLLOWING EC DIRECTIVES, INCLUDING THE MOST RECENT AMENDMENTS, AND THE RELEVANT NATIONAL HARMONISATION LEGISLATION CURRENTLY IN FORCE:
- RISULTA IN CONFORMITÀ CON QUANTO PREVISTO DALLE SEGUENTI DIRETTIVE CE, COMPRESSE LE ULTIME MODIFICHE, E CON LA RELATIVA LEGISLAZIONE NAZIONALE DI RECEPIMENTO:
- DEN IN DEN FÖLGENDE EG-RICHTLINIEN VORGESEHENEN VORSCHRIFTEN, EINSCHLIEßLICH DER LETZTEN ÄNDERUNGEN, SOWIE DEN ANGEWANDTEN LANDESGESETZEN ENTSPRICHT:
- EST CONFORME AUX DIRECTIVES CE SUIVANTES, Y COMPRIS LES DERNIÈRES MODIFICATIONS, ET À LA LÉGISLATION NATIONALE D'ACCUEIL CORRESPONDANTE:
- ES CONFORME A LAS SIGUIENTES DIRECTIVAS CE, INCLUIDAS LAS ÚLTIMAS MODIFICACIONES, Y A LA RELATIVA LEGISLACIÓN NACIONAL DE RECEPCIÓN:

- 2006/42/EC** **machinery directive**
direttiva macchine
Maschinenrichtlinie
directive sur les machines
directiva máquinas
- 2014/30/UE** **electromagnetic compatibility**
compatibilità elettromagnetica
Elektromagnetische Verträglichkeit
compatibilité électromagnétique
compatibilidad electromagnética
- 2009/125/CE** **Ecodesign /Progettazione ecocompatibile / Ecodesign / Éco-conception / Ecodiseño**
- 2011/65/UE** **RoHs**

-Unit manufactured and tested according to the followings Standards:
-Unità costruita e collaudata in conformità alle seguenti Normative:
-Unité construite et testée en conformité avec les Réglementations suivantes
-Unidad construida y probada de acuerdo con las siguientes Normativas
-Gebautes und geprüftes Gerät nach folgenden Normen

EN 60335-1 :2012/A13 :2017 EN 60335-2-40 :2003/A13 :2012
EN 62233 :2008 EN 61000-6-1 :2007 EN 61000-6-3 :2007/A1 :2011
EN 62321-1 :2013 EN 62321-2 :2014 EN 62321-3-1 :2014
EN 62321-4 :2014 EN 62321-5 :2014 EN 62321-6 :2015
EN 62321-7-1 :2015 EN 62321-7-2 :2017 EN 62321-8 :2017

-Responsible to constitute the technical file is the company n°00708410253 and registered at the Chamber of Commerce of Belluno Italy
-Responsabile a costituire il fascicolo tecnico è la società n° 00708410253 registrata presso la Camera di Commercio di Belluno Italia
-Verantwortliche für die technischen Unterlagen zusammenstellen n°00708410253 ist das Unternehmen bei der Handelskammer von Belluno Italien registriert
-Responsable pour compiler le dossier technique est la société n°00708410253 enregistrée à la Chambre de Commerce de Belluno en Italie
-Encargado de elaborar el expediente técnico es la empresa N° 00708410253 registrada en la Cámara de Comercio de Belluno Italia

FELTRE, 29/10/2018
NAME / NOME / VORNAME / PRÉNOM / NOMBRE
SURNAME / COGNOME / ZUNAME / NOM / APELLIDOS
COMPANY POSITION / POSIZIONE / BETRIEBSPOSITION / FONCTION / CARGO
LEGALE RAPPRESENTANTE



CLIVET DECLARATION OF CONFORMITY UE

DICHIARAZIONE DI CONFORMITÀ EU
KONFORMITÄT SERKLÄRUNG UE
DECLARATION DE CONFORMITE UE
DECLARACIÓN DE CONFORMIDAD UE

WE DECLARE UNDER OUR SOLE RESPONSIBILITY THAT THE MACHINE

DICHIARIAMO SOTTO LA NOSTRA SOLA RESPONSABILITÀ CHE LA MACCHINA
WIR ERKLÄREN EIGENVERANTWORTLICH, DASS DIE MASCHINE
NOUS DÉCLARONS SOUS NOTRE SEULE RESPONSABILITÉ QUE LA MACHINE
EL FABRICANTE DECLARA BAJO SU EXCLUSIVA RESPONSABILIDAD QUE LA MÁQUINA

CATEGORY	DIRECT EXPANSION TERMINALS - Heat pump
CATEGORIA	TERMINALI AD ESPANSIONE DIRETTA - Pompa di calore
KATEGORIE	DIREKTVERDAMPFUNGSGERÄTE - Wärmepumpe
CATEGORIE	TERMINAUX À DÉTENTE DIRECTE - Pompe à chaleur
CATEGORIA	TERMINALES POR EXPANSIÓN DIRECTA - Bomba de calor

TYPE / TIPO / TYP / TYPE / TIPO

MODEL
CN-2-XMi D400
CN-2-XMi D450
CN-2-XMi D560

- **COMPLIES WITH THE FOLLOWING EC DIRECTIVES, INCLUDING THE MOST RECENT AMENDMENTS, AND THE RELEVANT NATIONAL HARMONISATION LEGISLATION CURRENTLY IN FORCE:**
- RISULTA IN CONFORMITÀ CON QUANTO PREVISTO DALLE SEGUENTI DIRETTIVE CE, COMPRESE LE ULTIME MODIFICHE, E CON LA RELATIVA LEGISLAZIONE NAZIONALE DI RECEPIMENTO:
- DEN IN DEN FOLGENDEN EG-RICHTLINIEN VORGESEHENEN VORSCHRIFTEN, EINSCHLIEßLICH DER LETZTEN ÄNDERUNGEN, SOWIE DEN ANGEWANDTEN LANDESGESETZEN ENTSPRICHT:
- EST CONFORME AUX DIRECTIVES CE SUIVANTES, Y COMPRIS LES DERNIÈRES MODIFICATIONS, ET À LA LÉGISLATION NATIONALE D'ACCUEIL CORRESPONDANTE:
- ES CONFORME A LAS SIGUIENTES DIRECTIVAS CE, INCLUIDAS LAS ÚLTIMAS MODIFICACIONES, Y A LA RELATIVA LEGISLACIÓN NACIONAL DE RECEPCIÓN:

- 2006/42/EC** **machinery directive**
direttiva macchine
Maschinenrichtlinie
directive sur les machines
directiva máquinas
- 2014/30/UE** **electromagnetic compatibility**
compatibilità elettromagnetica
Elektromagnetische Verträglichkeit
compatibilité électromagnétique
compatibilidad electromagnética
- 2009/125/CE** **Ecodesign /Progettazione ecocompatibile / Ecodesign / Éco-conception / Ecodiseño**
- 2011/65/UE** **RoHs**

-Unit manufactured and tested according to the followings Standards:
-Unità costruita e collaudata in conformità alle seguenti Normative:
-Unité construite et testée en conformité avec les Réglementations suivantes
-Unidad construida y probada de acuerdo con las siguientes Normativas
-Gebautes und geprüftes Gerät nach folgenden Normen

EN 60335-1 :2012/A13 :2017 EN 60335-2-40 :2003/A13 :2012
EN 62233 :2008 EN 61000-6-1 :2007 EN 61000-6-3 :2007/A1 :2011
EN 62321-1 :2013 EN 62321-2 :2014 EN 62321-3-1 :2014
EN 62321-4 :2014 EN 62321-5 :2014 EN 62321-6 :2015
EN 62321-7-1 :2015 EN 62321-7-2 :2017 EN 62321-8 :2017

-Responsible to constitute the technical file is the company n°.00708410253 and registered at the Chamber of Commerce of Belluno Italy

-Responsabile a costituire il fascicolo tecnico è la società n° 00708410253 registrata presso la Camera di Commercio di Belluno Italia
-Verantwortliche für die technischen Unterlagen zusammenstellen n°.00708410253 ist das Unternehmen bei der Handelskammer von Belluno Italien registriert
-Responsable pour compiler le dossier technique est la société n°00708410253 enregistrée à la Chambre de Commerce de Belluno en Italie
-Encargado de elaborar el expediente técnico es la empresa N ° 00708410253 registrada en la Cámara de Comercio de Belluno Italia

FELTRE, 05/12/2019

NAME / NOME / VORNAME / PRÉNOM / NOMBRE	 STEFANO BELLÒ
SURNAME / COGNOME / ZUNAME / NOM / APELLIDOS	
COMPANY POSITION / POSIZIONE / BETRIEBSPOSITION / FONCTION / CARGO	LEGALE RAPPRESENTANTE

FOR 30 YEARS WE HAVE BEEN OFFERING
SOLUTIONS FOR SUSTAINABLE
COMFORT AND THE WELL-BEING OF
PEOPLE AND THE ENVIRONMENT

www.clivet.com

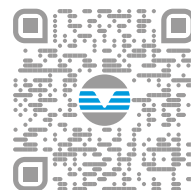

sales and service



CLIVET SPA

Via Camp Lonc 25, Z.I. Villapaiera
32032 Feltre (BL) - Italy
Tel. +39 0439 3131 - Fax +39 0439 313300
info@clivet.it

A Group Company of

