



1-WAY CASSETTE

Q1DN-2-XMi D18-D71

MANUAL
FOR INSTALLATION,
USE AND MAINTENANCE



Dear Customer,

Congratulations for having chosen this product.

Clivet has been working for years to offer the market systems able to assure maximum and long-lasting wellbeing with high reliability, efficiency, quality ad safety.

The company aim is that to offer its customers developed systems that assure the best comfort, reduce energy consumptions and installation and maintenance costs for the entire life-span of the system.

With this manual, we intend giving information useful throughout alla phases: from reception, to installation, to use and even disposal, so that such a developed system meets the best installation and use methods.

With kind regards and...good reading!

CLIVET Spa

The data contained in this manual is not binding and may be changed by the manufacturer with out prior notice
All reproduction, even partial, is PROHIBITED © Copyright - CLIVET S.p.A. - Feltre (BL) - Italia

Contents

	Page		
Installation manual	5	Part names	22
Safety Precaution	7	The explain of the display panel	22
Accessories	9	Air conditioner operations and performance	22
Before installation	10	Adjusting air flow direction	22
Choosing an installation site	10	Maintenance	23
Indoor unit installation	10	Symptoms that are not faults	24
Refrigerant piping installation	14	Troubleshooting	24
Water discharge piping installation	16	Wiring diagram	28
Electrical wiring (REVIEW)	17	Declaration of conformity UE	31
On-site configuration	19		
Test run	20		
Operation manual	20		

Page intentionally left blank

Installation manual

Page intentionally left blank

Installation Manual

Safety Precautions

Read carefully before you install the air conditioner to make sure that the installation is correct.

There are two types of precautions as described below:

⚠ Warning: Failure to comply may lead to death or serious injury.
⚠ Caution: Failure to comply may lead to injury or damage of the unit. Depending on the situation, this may also lead to serious injury. Once the installation is completed, and the unit has been tested and verified to be operating normally, please explain to the customer how to use and maintain the unit according to this manual. In addition, make sure that the manual is kept properly for future reference.

⚠ Warning

- Installation, maintenance and cleaning the filter work must be carried out by professional installers. Refrain from doing it yourself. Improper installation may cause water leakage, electric shock, or fire.
- Install the air conditioner according to the steps described in this manual. Improper installation may cause water leakage, electric shock, or fire.
- For installation in smaller rooms, you must adopt the relevant measures to prevent the refrigerant concentration from exceeding the limit. Please consult the sales agent on the relevant measures required. A high concentration of refrigerant in an airtight space can cause oxygen insufficiency (anoxia).
- Make sure the required parts and accessories are installed. Using unspecified parts may cause the air conditioner to malfunction or drop, as well as water leakage, electric shock, and fire.
- Mount the air conditioner in a place that is sturdy enough to bear its weight. If the base is not secured properly, the air conditioner may drop leading to damages and injuries.
- Take in full consideration to the effects of strong winds, typhoons and earthquakes, and reinforce the installation. Improper installation may cause the air conditioner to drop leading to accidents.
- Make sure a standalone circuit is used for the power supply. All electrical parts must comply with the local laws and regulations, and what is stated in this installation manual. The installation works must be carried out by a professional and qualified electrician. Insufficient capacity or improper electrical works can lead to electric shock or fire.
- Use only electrical cables that fulfil the specifications. All wiring on site must be carried out in accordance with the connection diagram attached to the product. Make sure that there are no external forces acting on the terminals and wires. Improper wiring and installation may cause a fire.
- Make sure the power cord, communication and controller wiring are straight and level when you are working on the connections, and the cover on the electric box is tight. If the electric box is not closed properly, it may lead to electric shock, fire or overheating of electrical components.
- If the refrigerant leaks during installation, open the doors and windows immediately to ventilate the area. Refrigerant can produce toxic gases when in contact with fire.
- Switch off the power supply before touching any electrical component.
- Do not touch the switch with wet hands. This is to prevent electrical shocks.
- Do not come in direct contact with the refrigerant leaking from the connections of refrigerant piping. Otherwise, it may lead to frostbite.
- The air conditioner must be grounded. Do not connect the earth line (ground) to gas piping, water piping, lightning rods or telephone earth lines. Improper grounding can lead to electric shock or fire, and may cause mechanical failure due to current surges from lightning and so on.
- The earth leakage circuit breaker must be installed. There is a risk of electric shock or fire if the earth leakage circuit breaker is not installed.
- The appliance shall be installed in accordance with national wiring regulations.
- The appliance must be installed 2,3m above floor.
- If the supply cord is damaged, it must be replaced by the manufacturer or its service agent or a similarly qualified person in order to avoid a hazard.
- An all-pole disconnection switch having a contact separation of at least 3mm in all poles should be connected in fixed wiring.
- The temperature of refrigerant circuit will be high, please keep the interconnection cable away from the copper tube.
- The power cord type designation is H05RN-For above/H07RN-F.
- Check the power supply before installation. Ensure that the power supply must be reliably grounded following local, state and National Electrical Codes. If not, for example, if the ground wire is detected charged, installation is prohibited before it is rectified. Otherwise, there is a risk of fire and electric shock, causing physical injury or death.
- Check the electric wire, water and gas pipeline layout inside the wall, floor and ceiling before installation. Do not implement drilling unless confirm safety with the user, especially for the hidden power wire. An electroprobe can be used to test whether a wire is passing by at the drilling location, to prevent physical injury or death caused by insulation broken cords.

 Caution







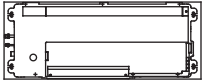

- Install the water discharge piping according to the steps described in this manual, and make sure that the water discharge is smooth, and the piping is properly insulated to prevent condensation.
- Improper installation of the water discharge piping may lead to water leakage, and damage the indoor furniture.
- When mounting the indoor and outdoor units, make sure the power cord is installed at a distance of at least 1 m away from any TV or radio so as to prevent noise or interference with the images.
- The refrigerant required for the installation is R410A. Make sure the refrigerant is correct before installation. Incorrect refrigerant may cause the unit to malfunction.

Do not install the air conditioner in the following places:



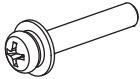
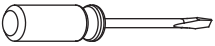

- 1) Where there is oil or gas, such as the kitchen. Otherwise, the plastic parts may age, fall off or water may leak.
 - 2) Where there are corrosive gases (such as sulphur dioxide). Corrosion in the copper pipes or welded parts may cause the refrigerant to leak.
 - 3) Where there are machines emitting electromagnetic waves. Electromagnetic waves may interfere with the control system, causing the unit to malfunction.
 - 4) Where there is a high salt content in the air. When exposed to air with a high salt content, the mechanical parts will experience accelerated ageing which will severely compromise the service life of the unit.
 - 5) Where there are major voltage fluctuations. Operating the unit using a power supply system that has large voltage fluctuations will reduce the service life of the electronic components, and cause the unit's controller system to malfunction.
 - 6) Where there is a risk of leakage of flammable gases. Examples are sites that contain carbon fibres or combustible dust in the air, or where there are volatile combustibles (such as diluent or petrol). The above gases may cause explosion and fire.
 - 7) Do not touch the fins of the heat exchanger as this may lead to injury.
 - 8) Some products use the PP packing belt. Do not pull or tug on the PP packing belt when you transport the product. It will be dangerous if the packing belt breaks.
 - 9) Note the recycling requirements for nails, wood, carton and other packaging materials. Do not discard these materials directly as these may lead to bodily harm.
 - 10) Tear up the packaging bag for recycling to prevent children from playing with it, and leading to suffocation.
 - 11) The appliance shall not be installed in the laundry.
- When the product is used for commercial application. This appliance is intended to be used by expert or trained users in shops, in light industry and on farms, or for commercial use by lay persons, the sound pressure level is below 70 dB(A).

Accessories

Verify that the air conditioner includes the following accessories.

Code	Name	Appearance	Qty	Purpose
1	Installation Manual for Indoor Unit	This manual	1	(Please make sure you hand over to the user)
2	Installation paper		1	For installation works on the boom, and to cut drop ceiling
3	Protection sleeve for refrigerant piping		2	For insulation of piping connections
4	Cable tie		10	For tightening and fixing
5	Water discharge hose		1	Connection between air conditioner and water discharge piping
6	Ring clamp		1	To secure the water discharge hose
7	Large washer		8	To secure the suspended air conditioner
8	Nut		8	To secure the suspended air conditioner
9	Installation screws for panel		7	Used to install the panel on the air conditioner (6 pieces for 18-36 models, 7 pieces for 45-71 models)
10	Slotted screwdriver		1	For installation of wiring/DIP switch (Included with 18-36 models only)
11	Brass nut		1	For connecting pipes
12	Connecting wire group		1	_____

Accessories to purchase locally

Code	Name	Appearance	Dimensions	Qty	Note
1	Copper pipe	_____	Choose and purchase copper pipes that correspond to the length and size calculated for the selected model in the installation manual of the outdoor unit and your actual project requirements.	To purchase based on actual project requirements.	Used to connect indoor refrigerant piping.
2	PVC pipe for water discharge		Outer diameter: 37-39 mm, inner diameter: 32 mm	To purchase based on actual project requirements.	Used to discharge condensed water from the indoor unit.
3	Insulation casing for piping		The inner diameter is based on the diameter of the copper and PVC pipes. The thickness of the pipe casing is 10 mm or more. Increase the thickness of the casing (20 mm or thicker) when the temperature exceeds 30°C or the humidity exceeds RH80%.	To purchase based on actual project requirements.	Protect piping from condensation.
4	Expansion hook anchor		M10	4	For installation of indoor unit
5	Mounting hooks		M10	4	For installation of indoor unit

1. Before Installation

1. Determine the route to move the unit to the installation site.
2. First unseal and unpack the unit. Then, hold the seats of the hanger (4 pcs) to move the unit. Refrain from exerting force on other parts of the unit, especially the refrigerant piping, water discharge piping, and the plastic parts.

2. Choosing an Installation Site

1. Choose a site that fully complies with the following conditions and user requirements to install the air conditioning unit.
 - ♦ Well ventilated.
 - ♦ Unobstructed airflow.
 - ♦ Strong enough to bear the weight of the indoor unit.
 - ♦ Ceiling has no obvious slant.
 - ♦ There is sufficient space for repair and maintenance work to be carried out.
 - ♦ No leakage of flammable gas.
 - ♦ The length of the piping between the indoor and outdoor units is within the permitted range (refer to the manual on installation of the outdoor unit).
2. Mounting height
 - ♦ Mounting height is 2.5 ~ 3.5 metres.
3. Mount using the mounting screws.
4. Space required for installation (unit (mm)):

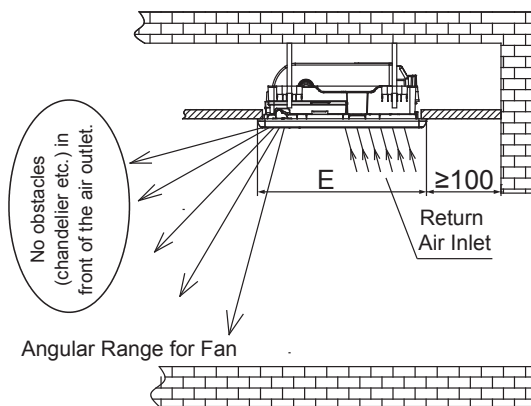
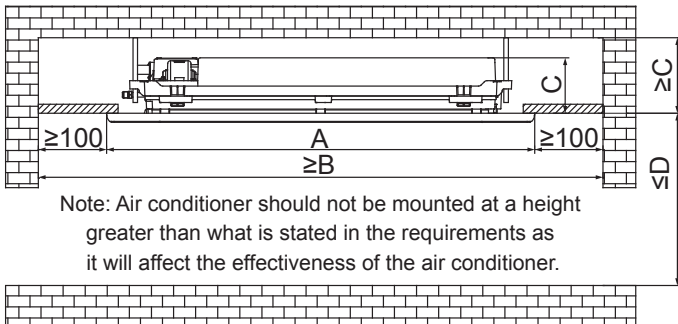

Figure 2.1

Model No.	18-36	45-71
A	1180	1350
B	1380	1550
C	153	189
D	3200	4000
E	465	505

5. Based on the shape of the room, determine the airflow directions for the installation site. See Figure 2.2 for the schematic on the direction of airflow.

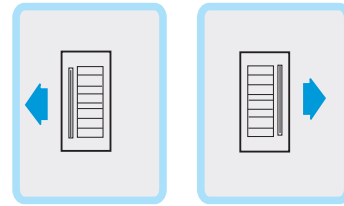

Figure 2.2

3. Indoor Unit Installation

Make sure that only specified components are used for the installation works.

3.1 Installation with Lifting Bolts

Use different bolts for the installation depending on the installation environment.

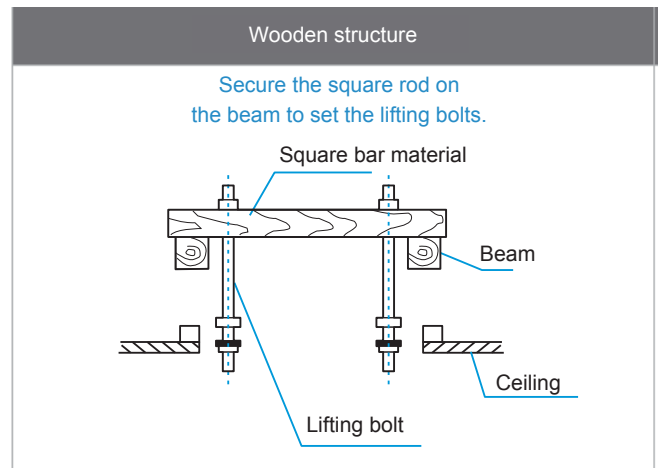

Figure 3.1

Original concrete slab structure

Use embedded bolts, and pull bolts.

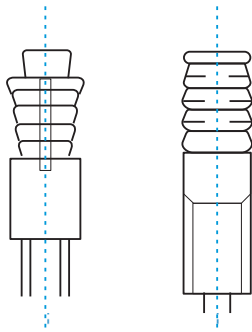

Figure 3.2

Steel framework

Directly set and use an angled steel rod for support.

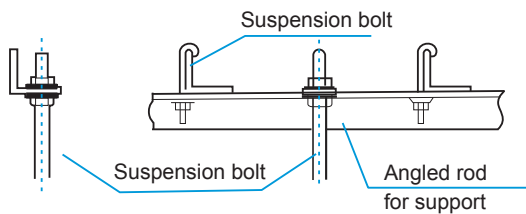

Figure 3.3

Newly set concrete slab structure

Set using embedded appliances, and embedded type of bolts.

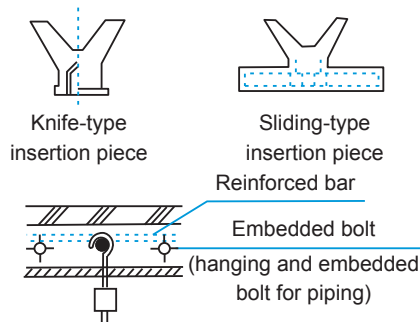

Figure 3.4

Caution

- All bolts should be made from high quality carbon steel (with galvanized surface or other rust prevention treatment) or stainless steel.
- How the ceiling should be handled will differ with the type of building. For specific measures, please consult the building and renovation engineers.
- How the lifting bolt should be secured depends on the specific situation, and it must be secure and reliable.

3.2. Indoor Unit Installation

3.2.1 Installation sequence for existing ceiling:

- Must maintain the ceiling at a level position.

1. Drill 430 mm x 1100 mm holes (18-36 models) or 470 mm x 1290 mm holes (45-71 models) into the ceiling based on the layout of the installation board (accessory Installation paper).
 - The centre of the ceiling opening should match the centre of the body of the indoor unit.
 - Determine the length and outlets of the connecting pipes, water discharge piping and the electrical wiring.
 - In order to keep the ceiling level and prevent vibrations, reinforce the strength of the ceiling when necessary.

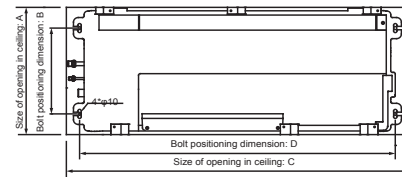

Model No.	18-36	45-71
A	430	470
B	290	300
C	1100	1290
D	1015	1235

Figure 3.5

2. Install the hooks in four corners based on the layout for the hooks outlined in the installation board (accessory Installation paper).
 - Determine the location on the ceiling of the room or building roof for mounting, and drill four $\Phi 12$ mm X 50-55 mm holes. Then embed and set up the expansion hook anchors (purchased accessory Expansion hook anchor) in these holes.
 - During the installation of the hooks (purchased accessory Mounting hooks), make sure that the concave portion of the hanger corresponds to that of the expansion hook anchors. Determine the appropriate hook length for installation based on the ceiling's height. Remove any excess.
 - Use M10 or W3/8" bolts for the screws of the mounting hooks.

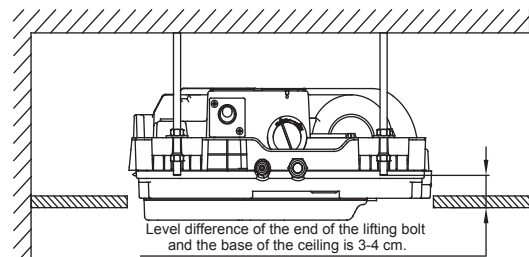

Figure 3.6

3. Use the hex nuts on the four mounting hooks to adjust and make sure that the unit body is level.
 - Adjust the height of Nut 2 so that the difference between the upper surface of Washer 2 and the base of the ceiling is as follows: A = 70 mm for 18-36 models, A = 75 mm for 45-71 models.
 - Suspend the air conditioner on the lifting bolt as shown in Figure 3.4. Use a spirit level to find the length and width at level. During the process, you need to repeatedly adjust four Nut 2 on the boom. This situation may arise: In making sure that the air conditioner is level, the height difference between Washer 2 of the four lifting bolts and the bottom surface of the ceiling may not be consistent, hence A is not uniform. At this time, the priority should be to ensure that the unit body is level. Level the entire unit up and down until four level differences are as close as possible to A.
 - Once you have adjusted the height and make sure that the unit body is level, use four Nut 1 on the boom to reliably secure the air conditioner.

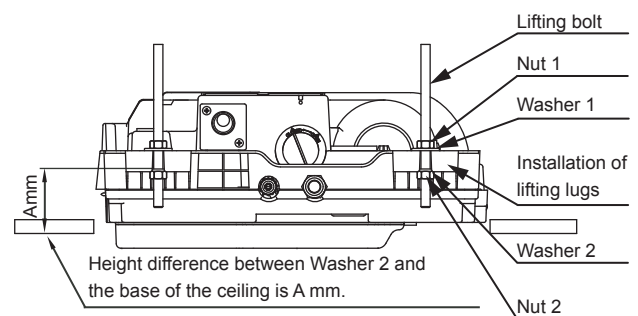

Figure 3.7

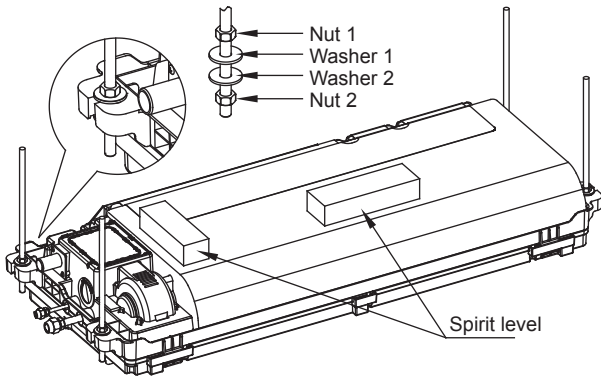

Figure 3.8

⚠ Caution

- If the unit body is not level, this can lead to water leakage, poor water drainage, and cracks in the panel and ceiling.

3.2.2 Installation sequence for new ceiling:

1. Refer to Step 2 of the "Installation sequence for existing ceiling". Pre-bury the hooks in the new ceiling, and make sure that they are strong enough to bear the weight of the indoor unit, and that the unit will not become loose when the concrete shrinks.
2. Once you have lifted and mounted the unit, use M6x12 screws (accessory Installation screws for panel) to secure the installation board (accessory installation paper) on the unit body. Make sure you verify the size and positions of the opening in the ceiling before you do so. See Figure 3.8.
 - Before you mount the unit onto the ceiling, make sure the ceiling is level.
 - The rest of the procedures are the same as Step 2 of the "Installation sequence for existing ceiling".
3. Refer to Step 3 of the "Installation sequence for existing ceiling".
4. Remove the installation board (accessory installation paper).
 - 2.1) Fold the installation paper, making sure that you fold in a direction such that the surface without text is protruding (Figures 3.9 - 3.10);
 - 2.2) Affix the installation paper on the lower side of the indoor unit with the screws used to secure the plate (see Figure 3.11).
 - 2.3) The size of the opening in the ceiling coincides with the size on the outside of the installation paper .
 - 2.4) Verify that the level difference between the lower side of the ceiling and the lower side of the installation paper is about 24 mm (see Figure 3.12). The hoisting height of the air conditioner is not correct if this requirement is not fulfilled.[AD1]

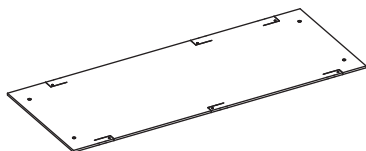

Figure 3.9

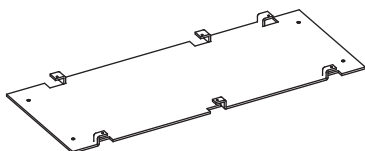

Figure 3.10

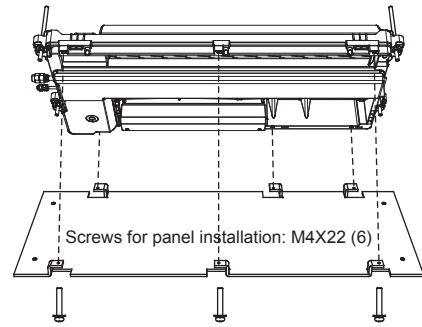

Figure 3.11

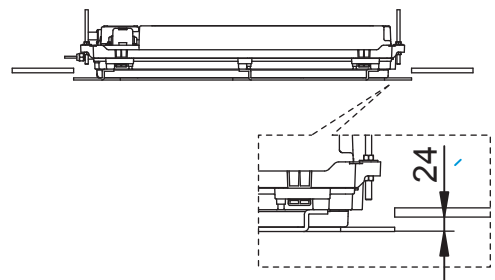

Figure 3.12

⚠ Caution

- Once the ceiling is cut, remove the installation paper. Make sure you keep the screws properly as you need them for the installation board.

3.3 Panel Installation

3.3.1 Remove the air inlet grille

- (1) Pull along the direction indicated by the grille switch arrow to unlock the buckle to remove the return air grille;

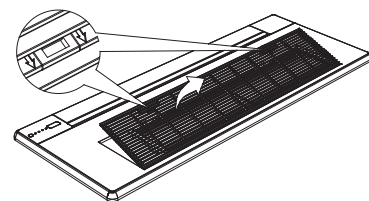

Figure 3.13

- (2) Toggle the buckle shown in the diagram to remove the filter;

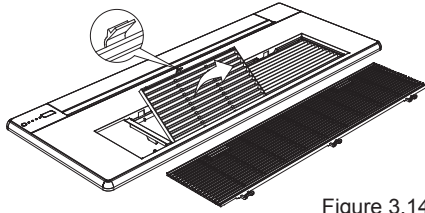

Figure 3.14

- (3) Open the fan guide vane and remove the three concealed-cap screws;

Open the fan guide vane and remove the three concealed-cap screws as indicated in the diagram. Make sure that the return air grille, filter, and concealed-cap screws are probably stored after removal.

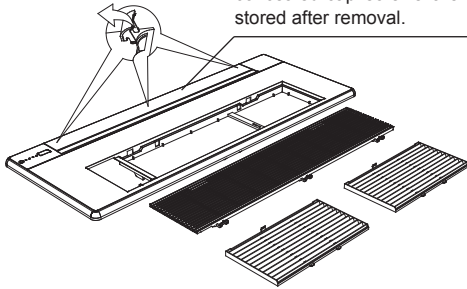

Figure 3.15

⚠ Caution

- Do not place the panel such that it faces downwards or leans against the wall. Do not place it on a protruding object either.
- Do not hit or squeeze the air deflector.

3.3.2 Panel installation

- 1) There are two buckle structures on the panel assembly for the installation of the auxiliary panel, and the assembly method of these buckles is as shown in Figure 3.16.
- 2) Electrical wiring for panel assembly: Open the cover plate of the electric control box of the air conditioner, connect the terminals of the control display of the panel assembly, and the terminals of the motor of the fan guide to the main controller board of the air conditioner as shown in the diagram.

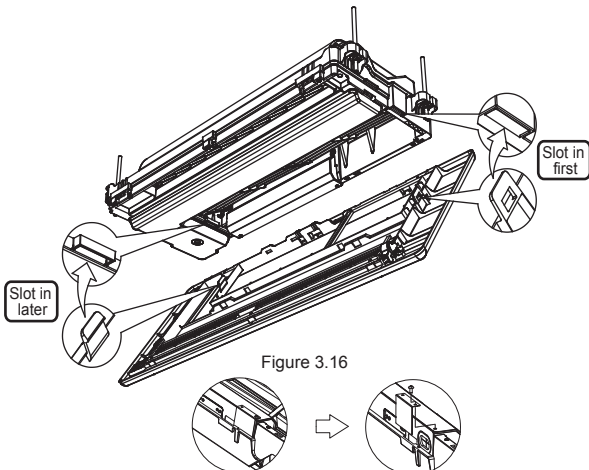

Figure 3.16

After the baffle is removed, the baffle is discarded.

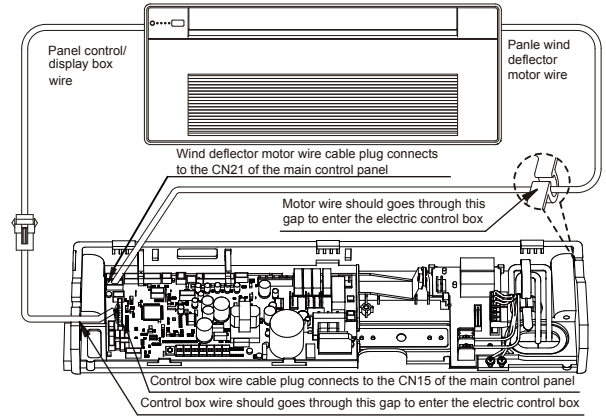

Figure 3.17 (18-36 model)

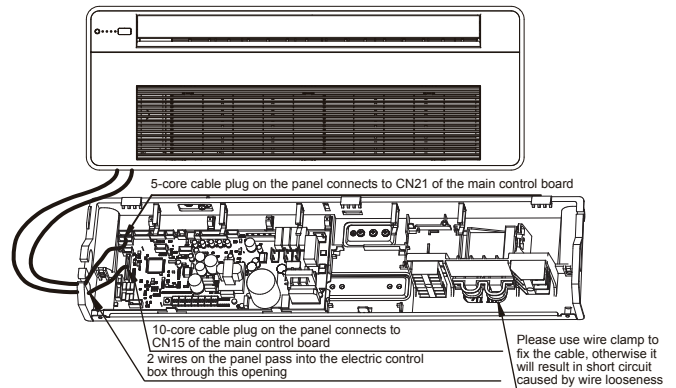

Figure 3.18 (45-71 model)

⚠ Caution

- Wiring for panel assembly
Follow what is indicated in the diagram strictly. The panel assembly may not work properly if the wiring is wrong. Connect the cables according to what is indicated in the installation schematic.
If the wiring is done properly, the cover of the electric control box can be closed correctly without clamping the wires. If the wires are clamped, this may lead to problems like air leakage and water condensation on the panel assembly.

3.3.3 Installation screws (example shown is a 18-36 model but method is also applicable to 45-71 models as well)

3.3.5 Putting back the filter and return air grille (example shown is a 18-36 model but method is also applicable to 45-71 models as well)

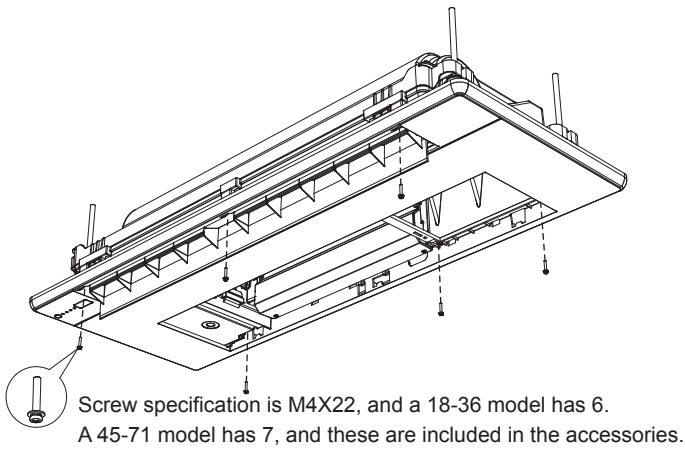

Figure 3.19

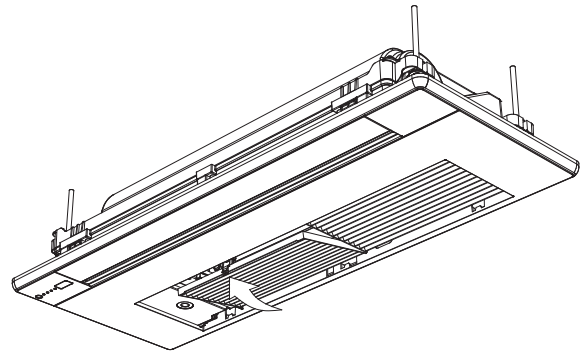

Figure 3.22

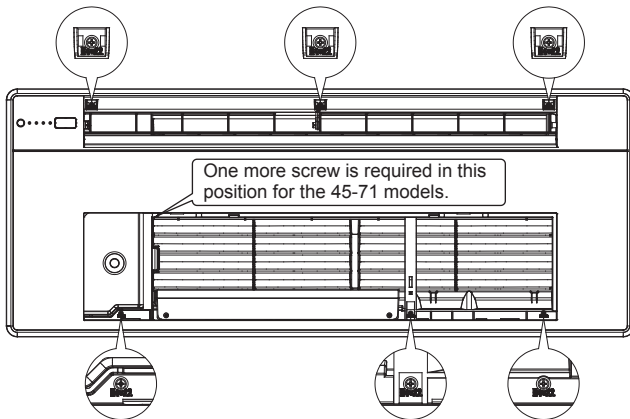

Figure 3.20

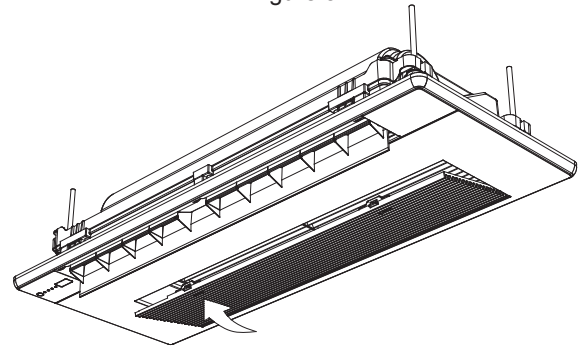
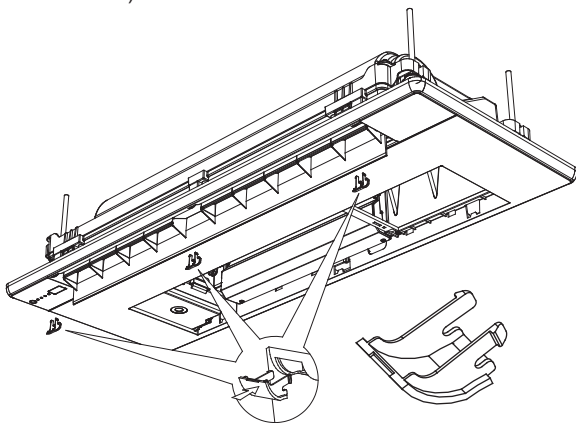

Figure 3.23

⚠ Caution

- Make sure the cables connected to the panel and air conditioner are not clamped before you install the screws. If the cable is clamped by the panel, you may damage the cable when you tighten the screws, and the panel may not work properly after installation.

3.3.4 Install concealed-cap screws on panel (example shown is a 18-36 model but method is also applicable to 45-71 models as well)



Panel with concealed-cap screws

Figure 3.21

4. Refrigerant Piping Installation

4.1 Length and Level Difference Requirements for the Piping Connections to the Indoor and Outdoor Units

The length and level difference requirements for the refrigerant piping are different for different indoor and outdoor units. Refer to the installation manual of the outdoor unit.

4.2 Piping Material and Size

1. Piping material: Copper pipes for air handling.
2. Piping size: Choose and purchase copper pipes that correspond to the length and size calculated for the selected model in the installation manual of the outdoor unit and your actual project requirements. Below are for reference only. See Figure 4.1.

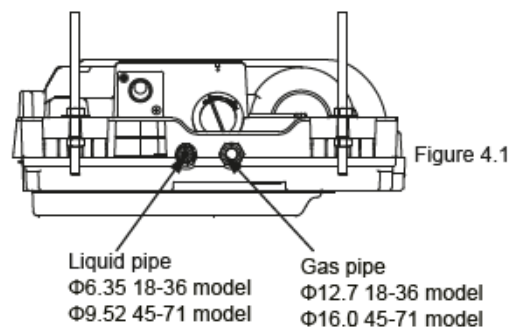

Figure 4.1

4.3 Piping Layout

1. Seal the two ends of the piping properly before you connect the indoor and outdoor piping. Once unsealed, connect the piping of the indoor and outdoor units as quickly as possible to prevent dust or other debris from entering the piping system via the unsealed ends, as this may cause the system to malfunction.
2. If the piping needs to go through walls, drill the opening in the wall, and place accessories like casings and covers for the opening properly.
3. Place the refrigerant connecting piping and the communication wiring for the indoor and outdoor units together, and bundle them tightly to make sure air does not enter and condensate to form water that may leak from the system.
4. Insert the bundled piping and wiring from outside the room through the wall opening into the room. Be careful when you lay out the piping. Do not damage the piping.

4.4 Piping Installation

- Refer to the installation manual attached with the outdoor unit on installation of the refrigerant piping for the outdoor unit.
- All gas and liquid piping must be properly insulated; otherwise, this may cause water to leak. Use heat insulation materials that can withstand high temperatures above 120°C to insulate the gas pipes. In addition, the insulation of the refrigerant piping should be reinforced (20 mm or thicker) in situations where there is high temperature and/or high humidity (when part of refrigerant piping part is higher than 30°C or when the humidity exceeds RH80%). Otherwise, the surface of the heat insulation material may be exposed.
- Before the works are carried out, verify that the refrigerant is R410A. If the wrong refrigerant is used, the unit may malfunction.
- Other than the specified refrigerant, do not let air or other gases enter the refrigeration circuit.
- If the refrigerant leaks during installation, make sure you fully ventilate the room.
- Use two wrenches when you install or dismantle the piping, a common wrench and a torque wrench. See Figure 4.2.

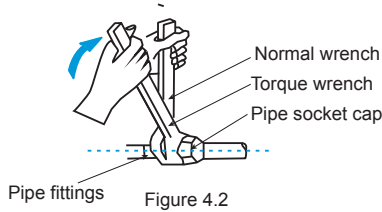

- Slot the refrigerant piping into the brass nut (accessory Brass nut), and expand the pipe socket. Refer to the following table for the size of the pipe socket and the appropriate tightening torque.

External diameter (mm)	Tightening torque	Flared opening diameter (A)	Flared opening
Φ6.35	14.2-17.2N·m	8.3-8.7mm	
Φ9.53	32.7-39.9N·m	12-12.4mm	
Φ12.7	49.5-60.3N·m	15.4-15.8mm	
Φ15.9	61.8-75.4N·m	18.6-19mm	
Φ19.1	97.2-118.6N·m	22.9-23.3mm	

⚠ Caution

- Apply the appropriate tightening torque according to the installation conditions. Excessive torque will damage the socket cap, and the cap will not be tight if you apply insufficient torque, leading to leakages.

- Before the socket cap is installed on the pipe socket, apply some refrigerant oil on the socket (both inside and outside), and then rotate it three or four times before you tighten the cap. See Figure 4.3.

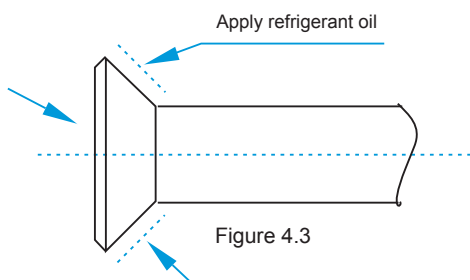

- Before you weld the refrigerant pipes, fill the pipes with nitrogen first to discharge the air in the pipes. If no nitrogen is filled during welding, a large amount of oxide film will form inside the piping which may cause the air conditioning system to malfunction.
- Welding can be carried out on the refrigerant pipes when the nitrogen gas has been replaced or refilled.
- When the pipe is filled with nitrogen during welding, the nitrogen must be reduced to 0.02 MPa using the pressure release valve. See Figure 4.4.

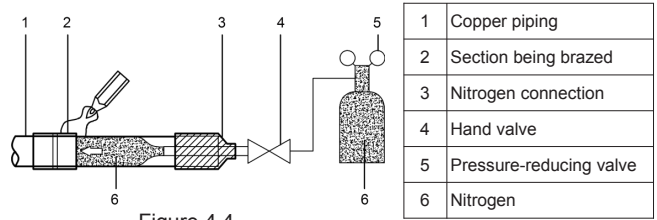

Figure 4.4

4.5 Air Tightness Test

Carry out the air tightness test on the system according to the instructions in the installation manual of the outdoor unit.

⚠ Caution

- The Air Tightness Test helps to ensure that the air and liquid cut-off valves of the outdoor unit are all closed (maintain the factory defaults).

4.6 Heat Insulation Treatment for Gas-Liquid Piping Connections for the Indoor Unit

- The heat insulation treatment is carried out on the piping at the gas and liquid sides of the indoor unit respectively.
 - a. The piping on the gas side must use heat insulation material that can withstand temperatures of 120°C and more.
 - b. For the piping connections of the indoor unit, use the insulation casing for copper pipes (accessory Protection sleeve for refrigerant piping) to carry out the insulation treatment, and close all gaps.

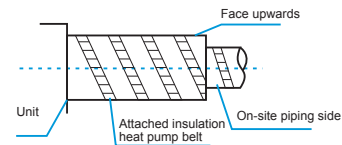

Figure 4.5

4.7 Vacuum

Create a vacuum in the system according to the instructions in the installation manual of the outdoor unit.

⚠ Caution

- For the vacuum, make sure that the air and liquid cut-off valves of the outdoor unit are all closed (maintain the factory status).

4.8 Refrigerant

Charge the system with refrigerant according to the instructions in the installation manual of the outdoor unit.

! SEE REVIEW AT THE END OF THE DOCUMENT

5. Water Discharge Piping Installation

5.1. Water Discharge Piping Installation for Indoor Unit

1. Use PVC pipes for the water discharge pipes (outer diameter: 37~39 mm, inner diameter: 32 mm). Based on the actual installation circumstance, users can purchase the appropriate piping length from sales agent or local after-sales service centre, or purchase directly from the local market.
2. Insert the water discharge pipe into the end of the water suction connecting pipe of the unit body, and use the ring clamp (accessory Ring clamp) to clamp the water discharge pipes with the insulation casing for the water outlet piping securely.
3. Use the insulation casing for water discharge piping (accessory Insulation casing for piping) to bundle the water suction and discharge pipes of the indoor unit (especially the indoor portion), and use the tie for the water discharge piping (accessory Cable tie) to bind them firmly to make sure air does not enter and condense.
4. In order to prevent the back-flow of water into the interior of the air conditioner when the operation stops, the water discharge pipe should slope downwards towards the outside (drainage side) at a slope of more than 1/100. Make sure that the water discharge pipe does not swell or store water; otherwise, it will cause strange noises. See Figure 5.1.
5. When connecting the water discharge piping, do not use force to pull the pipes to prevent the water suction pipe connections from coming loose. At the same time, set a supporting point at every 0.8~1 m to prevent the water discharge pipes from bending. See Figure 5.1.

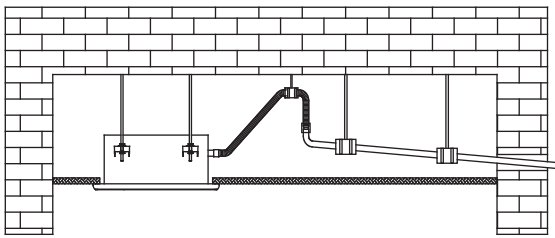

Figure 5.1

6. When connecting to a long water discharge pipe, the connections must be covered with the insulation casing to prevent the long pipe from coming loose.
7. When the outlet of the water discharge pipe is higher than the pipe connection for water suction, try to keep the water discharge pipe as vertical as possible, and the water outlet connecting fittings will bend so that the height of the water discharge pipe should be within 1000 mm away from the base of the water pan. Otherwise there will be excessive water flow when the operation stops.

Water discharge pipes from multiple units are connected to the main water discharge pipe to be discharged through the sewage pipe.

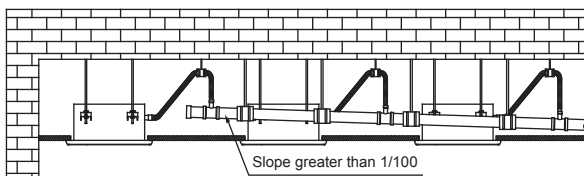

Figure 5.2

8. The end of the water discharge pipe must be more than 50 mm above the ground or from the base of the water discharge slot. Besides, do not put it in the water.

⚠ Caution

- Make sure all the connections in the piping system are properly sealed to prevent water leakages.

9. Drainage system design requirements

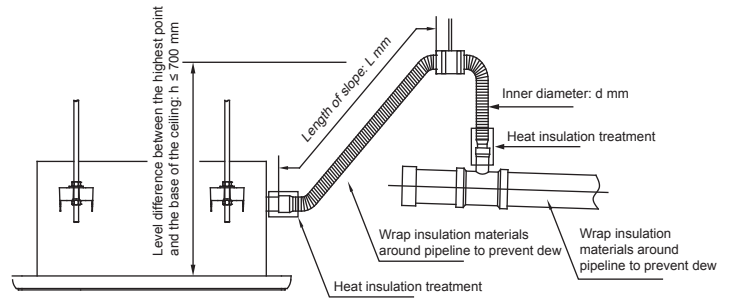

Figure 5.3

Description:

Length of slope, L, and inner diameter of the pipe, d, should satisfy the relation: $L \cdot d \leq 650000$ (L and d are in millimetres)

That is, the volume inside the water pipe in the slope section is not more than 500 ml. Excessive accumulated water in the piping on the slope will lead to problems like poor drainage, backflow, and water leakage.

Installation works for the water pipes must be based on the requirements. Recommendation is to use a pipe with an inner diameter of 25 mm, and the length of the slope is not more than 1 m.

5.2 Water Discharge Test

- Before the test, make sure that the water discharge pipeline is smooth, and check that each connection is sealed properly.
 - Conduct the water discharge test in the new room before the ceiling is paved.
1. Connect the power supply, and set the air conditioner to operate in the cool mode. Check the running sound of the drainage pump.

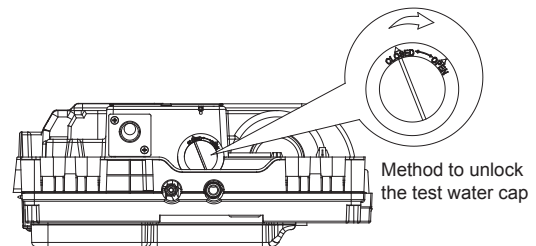

Figure 5.4

2. Remove the test water cap to connect to the test water outlet to inject water into the water pan, and at the same time, observe if there is any water discharged from the drainage outlet. Make sure water is discharged normally from the water drainage outlet.
3. Stop the air conditioner. Wait for three minutes, and then check if there is anything unusual. If the water discharge piping layout is not correct, the excessive water flow will cause the water level error and "EE" error code will be displayed on the display panel. There may even be water overflowing from the water pan.
4. Continue to add water until the alarm for excessive water levels is triggered. Check if the drainage pump drains water immediately. After three minutes, if the water level does not fall below the warning level, the unit will shut down. At this time, you need to turn off the power supply, and drain away the accumulated water before you can turn on the unit normally.
5. Turn off the power supply, remove the water manually using the drainage plug, and put the test cap back to the original place.

⚠ Caution

- The drainage plug at the bottom of the unit body is used to discharge accumulated water from the drain pan when the air conditioner malfunctions. When the air conditioner is operating normally, make sure the drainage plug is properly plugged to prevent water from leaking.

6 Electrical Wiring

Warning

- All the supplied parts, materials and electrical works must comply with local regulations.
- Use only copper wires.
- Use a dedicated power supply for the air-conditioners. The power voltage must be in line with the rated voltage.
- The electrical wiring works must be carried out by a professional technician, and must comply with the labels stated in the circuit diagram.
- Before the electrical connection works are carried out, turn off the power supply to prevent injuries caused by electric shock.
- The external power supply circuit of the air conditioner must include an earth line, and the earth line of the power cord connecting to the indoor unit must be securely connected to the earth line of the external power supply.
- Leakage protective devices must be configured according to the local technical standards and requirements for electrical and electronic devices.
- The fixed wiring connected must be equipped with an all-pole disconnection device with a minimum 3 mm contact separation.
- The distance between the power cord and signalling line must be at least 300 mm to prevent the occurrences of electrical interference, malfunction or damage to electrical components. At the same time, these line must not come in contact with the piping and valves.
- Choose electrical wiring that conforms to the corresponding electrical requirements.
- Connect to the power supply only after all the wiring and connection works have been completed, and carefully checked to be correct.

SEE REVIEW AT THE END OF THE DOCUMENT

6.1 Power Cord Connection

- Use a dedicated power supply for the indoor unit that is different from the power supply for the outdoor unit.
- Use the same power supply, circuit breaker and leakage protective device for the indoor units connected to the same outdoor unit.

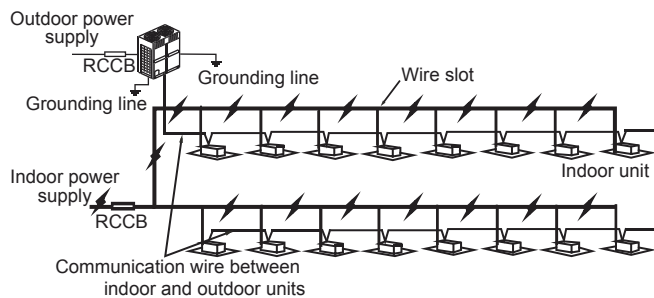

Figure 6.1

Figure 6.2 shows the power supply terminal of the indoor unit.

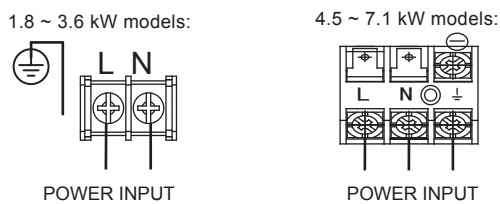

Figure 6.2

When connecting to the power supply terminal, use the circular wiring terminal with the insulation casing (see Figure 6.3).

Use power cord that conforms to the specifications and connect the power cord firmly. To prevent the cord from being pulled out by external force, make sure it is fixed securely.

If circular wiring terminal with the insulation casing cannot be used, please make sure that:

- Do not connect two power cords with different diameters to the same power supply terminal (may cause overheating of wires). See Figure 6.4.

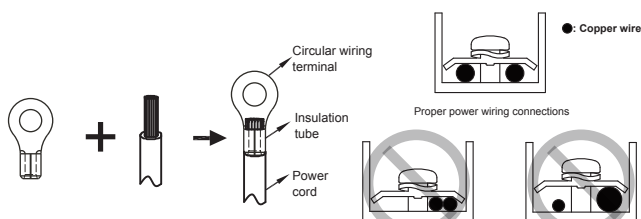

Figure 6.3

Figure 6.4

6.2 Electrical Wiring Specifications

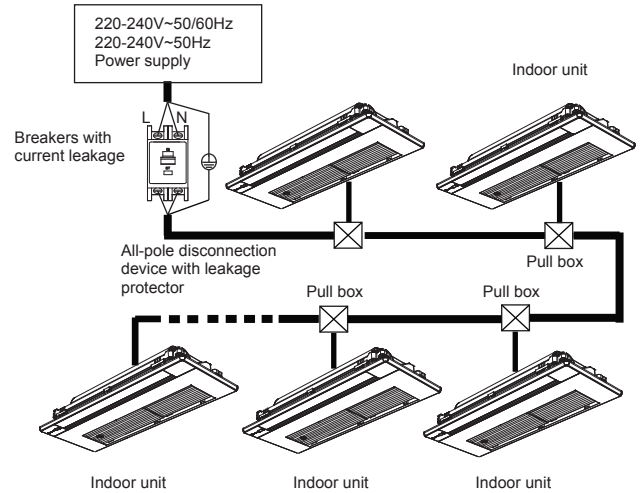

Figure 6.5

Refer to Tables 6.1 and 6.2 for the specifications of the power cord and communication wire. A wiring capacity that is too small will cause the electrical wiring to become too hot, and lead to accidents when the unit burns and becomes damaged.

Table 6.1

Model	1.8-7.1kW	
Power supply	Phase	1-phase
	Volt and frequency	220-240V~50Hz 220-240V~50/60Hz
Communication wire between indoor and outdoor units	Shielded 3×AWG16-AWG18	
Communication wire between indoor unit and wired controller *	Shielded AWG16-AWG20	
Field fuses	15A	

* Please refer to the corresponding wired controller manual for the wired controller wiring.

Table 6.2 Indoor units electrical characteristics

Capacity	Power supply				IFM	
	Hz	Volts	MCA	MFA	kW	FLA
1.8kW	50 50/60	220-240	0.38	15	0.02	0.30
2.2kW			0.38	15	0.02	0.30
2.8kW			0.39	15	0.02	0.31
3.6kW			0.39	15	0.02	0.31
4.5kW			0.53	15	0.06	0.42
5.6kW			0.57	15	0.06	0.46
7.1kW			0.59	15	0.06	0.47

Abbreviations:

MCA: Minimum Circuit Amps

MFA: Maximum Fuse Amps

IFM: Indoor Fan Motor

kW: Rated motor output

FLA: Full Load Amps

Warning

Refer to local laws and regulations when deciding on the dimensions for the power cords and wiring. Get a professional to select and install the wiring.

6.3 Communication Wiring

- Use only shielded wires for the communication wiring. Any other type of wires may produce a signal interference that will cause the units to malfunction.
- Do not carry out electrical works like welding with the power on.
- All shielded wiring in the network are interconnected, and will eventually connect to earth at the same point "⊕".
- Do not bind the refrigerant piping, power cords and communication wiring together. When the power cord and communication wiring are parallel, the distance between the two lines must be 300 mm or more in order to prevent signal source interference.
- Communication wiring must not form a closed loop.

6.3.1 Communication wiring between the indoor and outdoor units

- The indoor and outdoor units communicate via the RS485 serial port.
- The communication wiring between the indoor and outdoor units should connect one unit after another in a daisy chain from the outdoor unit to the final indoor unit, and the shielded layer must be properly grounded, and a build-out resistor must be added to the last indoor unit to enhance the stability of the communication system (see Figure 6.6).
- Incorrect wiring such as a star connection or a closed ring will cause instability of the communication system and system control anomalies.
- Use a three core shielded wire (greater than or equal to 0.75 mm²) for the communication wiring between the indoor and outdoor units. Make sure the wiring is connected correctly. The connecting lead for this communication wire must come from the master outdoor unit.

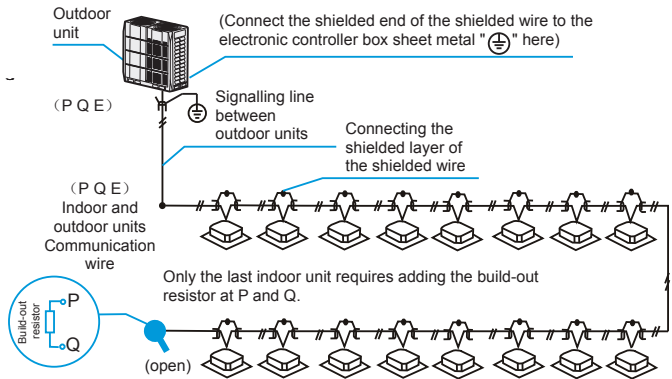

Figure 6.6

6.3.2 Communication wiring between the indoor unit and wired controller

The wired controller and the indoor unit can be connected in different manners, depending on the forms of communication.

1) For a bidirectional communication mode:

- Use 1 wired controller to control 1 indoor unit or 2 wired controllers (one master and one slave controller) to control 1 indoor unit (see Figure 6.7);
- Use 1 wired controller to control multiple indoor units or 2 wired controllers (one master and one slave controller) to control multiple indoor units (see Figure 6.8);

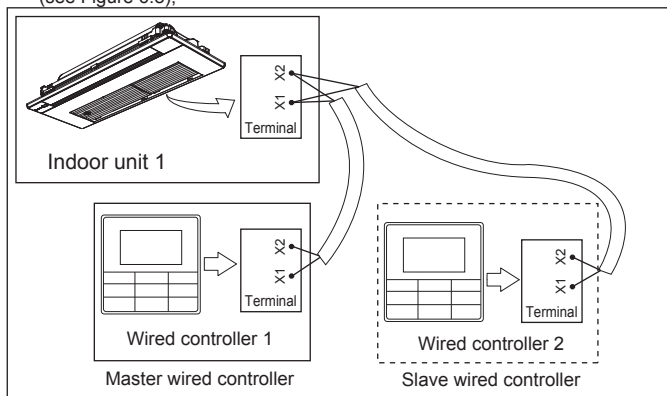

Figure 6.7

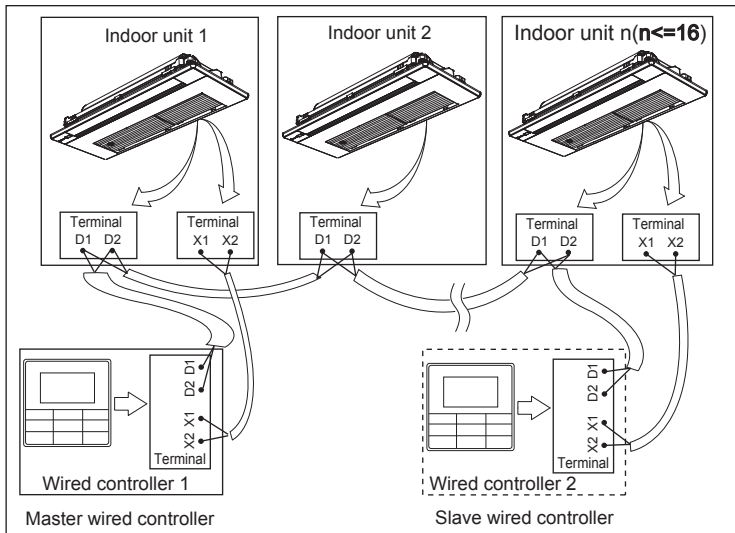

Figure 6.8

2) For a unidirectional communication mode:

- Use 1 wired controller to control 1 indoor unit (see Figure 6.9).

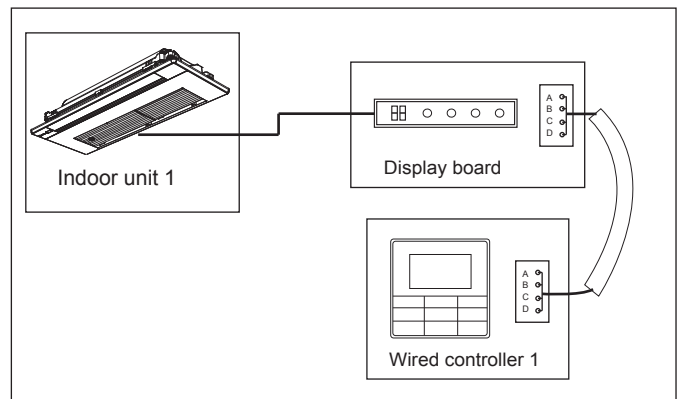

Figure 6.9

- The X1/X2, D1/D2 terminals on the sides of the main control board and the unidirectional communications terminal (display board) are for different types of wired controllers (see Figures 6.10 and 6.11).
- Use the connecting wires (accessories) to connect the D1/D2 terminals.

1.8 ~ 3.6 kW models - Wiring diagram page 28

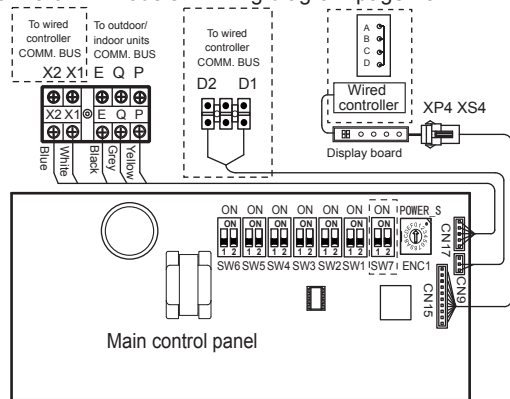

Figure 6.10

4.5 ~ 7.1 kW models - Wiring diagram page 29

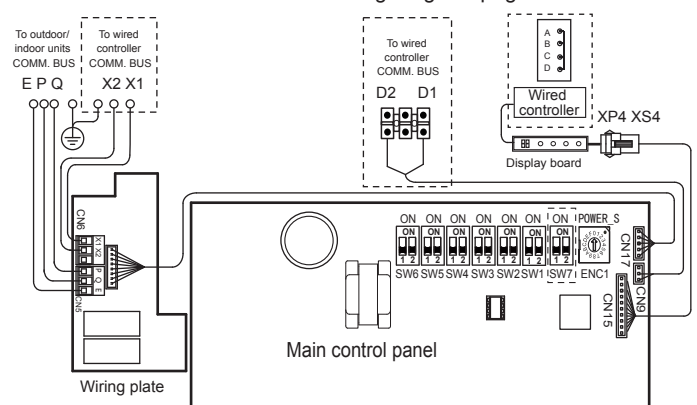

Figure 6.11

⚠ Caution

- For the specific connection method, refer to the instructions in the corresponding wired controller manual to carry out the wiring and connections.

6.4 Handling the Electrical Wiring Connection Points

- Once the wiring and connections are done, use tie straps to secure the wiring properly so that the connection joint cannot be pulled apart by external force. The connection wiring must be straight out so that the cover of the electrical box is level and can be closed tightly.
- Use professional insulation and sealing materials to seal and protect the perforated wires. Poor sealing may lead to condensation, and entry of small animals and insects that may cause short circuits in parts of the electrical system, causing the system to fail.

7. On-site Configuration

7.1 Capacity Settings

Set up the PCB DIP switch on the indoor electric control box to cater to different uses. Once the settings are done, make sure you cut off the main power switch again, and then switch the power on. If the power is not cut off and switched on again, the settings will not be executed.

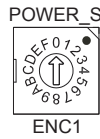

ENC1 Settings for Capacity DIP Switch:

DIP Switch Code	Capacity
0	1800W
0	2200W
1	2800W
2	3600W
3	4500W
4	5600W
5	7100W

⚠ Caution

- The capacity DIP switches have been configured before delivery. Only a professional maintenance personnel should change these settings.

7.2 Address Settings

When this indoor unit is connected to the outdoor unit, the outdoor unit will automatically allocate the address to the indoor unit. Alternatively, you may use the controller to manually set the address.

- The addresses of any two indoor units in the same system cannot be the same.
- The network address and the indoor unit address are the same, and does not have to be configured separately.
- Once the address settings are completed, mark the address of each indoor unit to facilitate after-sales maintenance.
- The centralized control of the indoor unit is completed on the outdoor unit. For details, refer to the manual on the outdoor unit.

⚠ Caution

- Once the centralized control function for the indoor unit has been completed on the outdoor unit, the DIP switch on main control panel of the outdoor unit must be set to auto addressing; otherwise, the indoor unit in the system are not controlled by the centralized controller.
- The system can connect up to 64 indoor units (address 0~63) at the same time. Each indoor unit can only have one address DIP switch in the system. The addresses of any two indoor units in the same system cannot be the same. Units that have the same address may malfunction.

7.3 DIP Switch Settings on Main Board

0/1 definition of each dial code switch:

	means 0		means 1
--	---------	--	---------

SW1_1	
SW1 [0]	Cooling mode temperature compensation is 0°C
SW1 [1]	Cooling mode temperature compensation is 2°C
SW1_2	
SW1 [0]	EEV at position 96 (steps) in standby in heating mode
SW1 [1]	EEV at position 72 (steps) in standby in heating mode

SW2	
SW2 [00]	Factory settings

SW3_1	
SW3 [0]	Reserved
SW3 [1]	Clear indoor unit address

SW3_2	
SW3 [0]	Reserved

SW4	
SW4 [00]	In heating mode when the set temperature has been reached, the fan operates in a 4 minutes off / 1 minute on repeating cycle
SW4 [01]	In heating mode when the set temperature has been reached, the fan operates in an 8 minutes off / 1 minute on repeating cycle
SW4 [10]	In heating mode when the set temperature has been reached, the fan operates in a 12 minutes off / 1 minute on repeating cycle
SW4 [11]	In heating mode when the set temperature has been reached, the fan operates in a 16 minutes off / 1 minute on repeating cycle

SW5	
SW5 [00]	In heating mode fan does not run when indoor heat exchanger mid-point temperature is 15°C or below
SW5 [01]	In heating mode fan does not run when indoor heat exchanger mid-point temperature is 20°C or below
SW5 [10]	In heating mode fan does not run when indoor heat exchanger mid-point temperature is 24°C or below
SW5 [11]	In heating mode fan does not run when indoor heat exchanger mid-point temperature is 26°C or below

SW6	
SW6 [00]	Heating mode temperature compensation is 6°C
SW6 [01]	Heating mode temperature compensation is 2°C
SW6 [10]	Heating mode temperature compensation is 4°C
SW6 [11]	Heating mode temperature compensation is 0°C (use follow me function)

SW7: reserved	
J1	Auto restart function enabled
J1	Auto restart function disabled

SW7: reserved

J1	
J1	Auto restart function enabled
J1	Auto restart function disabled

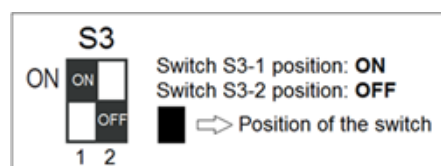

Caution

- All DIP switches (including the capacity DIP switch) have been configured before delivery. Only a professional maintenance personnel should change these settings.
- Improper DIP switch settings may cause condensation, noise, or unexpected system malfunction.

7.4 Error Codes and Definitions

Error code	Content
E0	Mode conflict
E1	Communication error between indoor and outdoor units
E2	Indoor ambient temperature sensor (T1) error
E3	Indoor heat exchanger mid-point temperature sensor (T2) error
E4	Indoor heat exchanger outlet temperature sensor (T2B) error
E6	Fan error
E7	EEPROM error
Eb	Indoor EEV coil error
Ed	Outdoor unit error
EE	Water level error
FE	Indoor unit has not been assigned an address

8. Test Run

8.1 Things to Note Before Test Run

- Indoor and outdoor units are properly installed;
- Piping and wiring are correct;
- No leakage from the refrigerant piping system;
- Water discharge is smooth;
- Insulation is complete;
- Grounding line has been properly connected;
- Piping length, and amount of refrigerant filled have been recorded;
- The voltage of the power supply is the same as the rated voltage of the air conditioner;
- No obstacles at the air inlet and outlet of the indoor and outdoor units;
- Cut-off valves for the gas and liquid ends of the outdoor unit are opened;

8.2. Test Run



When the wired/remote controller is used to set the cooling operations of the air conditioner, check the following items one by one. If there is a fault, troubleshoot according to the manual.

- Function keys of the wired/remote controller are operating normally;
- Room temperature regulation is normal;
- LED indicator is on;
- Water discharge is normal;
- No vibration and strange sounds during operation;

Note: Once the power is connected, when the unit is turned on or started immediately after the unit is turned off, the air conditioner has a protective function which delays the start of the compressor.

Operation manual

There are two types of precautions as described below:

-  Warning: Failure to comply may lead to death or serious injury.
-  Caution: Failure to comply may lead to injury or damage of the unit. Depending on the situation, this may also lead to serious injury. Once the installation is completed, please keep the manual properly for future reference. When this air conditioner is handed over to other users, make sure that the manual is included with the handover.

Warning

- Do not use this unit in locations where flammable gas may exist. If flammable gas comes into contact with the unit, a fire may occur, which could result in serious injury or death.
- If this unit exhibits any abnormal behavior (such as emitting smoke) there is a danger of serious injury. Disconnect the power supply and contact your supplier or service engineer immediately.
- The refrigerant in this unit is safe and should not leak if the system is designed and installed properly. However, if a large amount of refrigerant leaks into a room, the oxygen concentration will decrease rapidly, which can cause serious injury or death. The refrigerant used in this unit is heavier than air, so the danger is greater in basements or other underground spaces. In the event of a refrigerant leak, turn off any devices that produce a naked flame and any heating devices, ventilate the room, and contact your supplier or service engineer immediately.
- Toxic fumes may be produced if the refrigerant in this unit comes into contact with naked flames (such as from a heater, gas stove/burners, or electric appliances).
- If this unit is used in the same room as a cooker, stove, hob, or burner, ventilation for sufficient fresh air must be ensured, otherwise the oxygen concentration will fall, which may cause injury.
- Dispose of this unit's packaging carefully, so children cannot play with it. Packaging, especially plastic packaging, can be dangerous, can cause serious injury or death. Screws, staples and other metal packaging components can be sharp and should be disposed of carefully to avoid injury.
- Do not attempt to inspect or repair this unit yourself. This unit should only be serviced and maintained by a professional air conditioning service engineer. Incorrect servicing or maintenance can cause electric shocks, fire or water leaks.
- This unit should only be re-positioned or re-installed by a professional technician. Incorrect installation can lead to electric shocks, fire or water leaks. The installation and grounding of electrical appliances should only be carried out by licensed professionals. Ask your supplier or installation engineer for further information.
- Do not allow this unit or its remote controller to come into contact with water, as this can lead to electric shocks or fire.

- Turn off the unit before cleaning it to avoid electric shocks. Otherwise, an electric shock and injury may result.
- To avoid electric shocks and fires, install an earth leakage detector.
- Do not use paint, varnish, hair spray, other flammable sprays or other liquids that may give off flammable fumes/vapor near this unit, as doing so can cause fires.
- When replacing a fuse, ensure that the new fuse to be installed completely complies with requirements.
- Do not open or remove the unit's panel when the unit is powered on. Touching the unit's internal components while the unit is powered on can lead to electric shocks or injuries caused by moving parts such as the unit's fan.
- Ensure that the power supply is disconnected before any servicing or maintenance is carried out.
- Do not touch the unit or its remote controller with wet hands, as doing so can lead to electric shocks.
- Do not allow children to play near this unit, as doing so risks injury.
- Do not insert your fingers or other objects into the unit's air inlet or air outlet to avoid injury or damage to the equipment.
- Do not spray any liquids onto the unit or allow any liquids to drip onto the unit.
- Do not place vases or other liquid containers on the unit or in places where liquid could drip onto it. Water or other liquids that come into contact with the unit can lead to electric shocks or fires.
- Do not remove the remote controller's front or back covers and do not touch the remote controller's internal components, as doing so can cause injury. If the remote controller stops working, contact your supplier or service engineer.
- Ensure that the unit is properly grounded, otherwise electric shocks or a fire may result. Electrical surges (such as those that can be caused by lightning) can damage electrical equipment. Ensure that suitable surge protectors and circuit breakers are properly installed, otherwise electric shocks or a fire may result.
- Dispose of this unit properly and in accordance with regulations. If electrical appliances are disposed of in landfills or dumps, hazardous substances can leak into the groundwater and thus enter the food chain.
- Do not use the unit until the qualified technician instructs you that it is safe to do so.
- Do not place appliances that produce naked flames in the path of the airflow from the unit. The airflow from the unit may increase the rate of combustion, which may cause a fire and cause serious injury or death. Alternatively, the airflow may cause incomplete combustion which can lead to reduced oxygen concentration in the room, which can cause serious injury or death.

Caution

- Only use the air conditioner for its intended purpose. This unit should not be used to provide refrigeration or cooling for food, plants, animals, machinery, equipment or art.
- Do not insert your fingers or other objects into the unit's air inlet or air outlet to avoid injury or damage to the equipment.
- The fins on the unit's heat exchanger are sharp and can cause injury if touched. To prevent injury, when the unit is being serviced,

gloves should be worn or the heat exchanger should be covered.

- Do not place items which might be damaged by moisture under the unit. When the humidity is greater than 80% or if the drain pipe is blocked or the air filter is dirty, water could drip from the unit and damage objects placed under the unit.
- Ensure that the drain pipe functions properly. If the drain pipe is blocked by dirt or dust, water leaks may occur when the unit is running in cooling mode. If this happens, turn the unit off and contact your supplier or service engineer.
- Do not touch the internal parts of the controller. Do not remove the front panel. Some internal parts may cause injury or be damaged.
- Ensure that children, plants and animals are not directly exposed to the airflow from the unit.
- When fumigating a room with insecticide or other chemicals, cover the unit well and do not run it. Failure to observe this caution could lead to chemicals getting deposited inside the unit and later emitted from the unit when it running, endangering the health of any room occupants.
- Do not dispose of this product as unsorted waste. It must be separately collected and processed. Ensure that all applicable legislation regarding the disposal of refrigerant, oil and other materials is adhered to. Contact your local waste disposal authority for information about disposal procedures.
- To avoid damaging the remote controller, exercise caution when using it and replacing its batteries. Do not place objects on top of it.
- Do not place appliances that have naked flames under or near the unit, as heat from the appliance can damage the unit.
- Do not place the unit's remote controller in direct sunlight. Direct sunlight can damage the remote controller's display.
- Do not use strong chemical cleaners to clean the unit, as doing so can damage the unit's display or other surfaces. If the unit is dirty or dusty, use a slightly damp cloth with very diluted and mild detergent to wipe the unit. Then, dry it with a dry cloth.
- Children shall not play with the appliance.
- Do not dispose of this product as unsorted waste. It must be separately collected and processed. Ensure that all applicable legislation regarding the disposal of refrigerant, oil and other materials is adhered to. Contact your local waste disposal authority for information about disposal procedures.
- This appliance is not intended for use by persons (including children) with reduced physical, sensory or mental capabilities, or lack of experience and knowledge, unless they have been given supervision or instruction concerning use of the appliance by a person responsible for their safety. Children should be supervised to ensure that they do not play with the appliance.
- This appliance can be used by children aged from 8 years and above and persons with reduced physical, sensory or mental capabilities or lack of experience and knowledge if they have been given supervision or instruction concerning use of the appliance in a safe way and understand the hazards involved. Children shall not play with the appliance. Cleaning and user maintenance shall not be made by children without supervision.



9. Part Names

The figure shown above is for reference only and may be slightly different from the actual product.

Air Outlet Louver (adjustable)

For in-situ adjustment to three-direction or two-direction, please contact the local dealer.

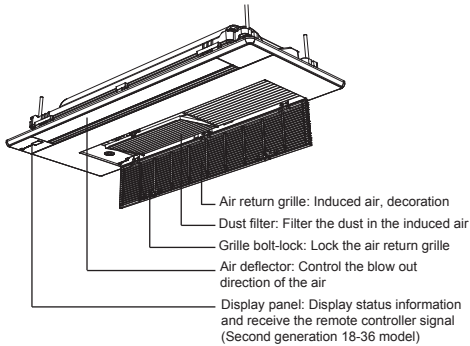

Figure 9.1

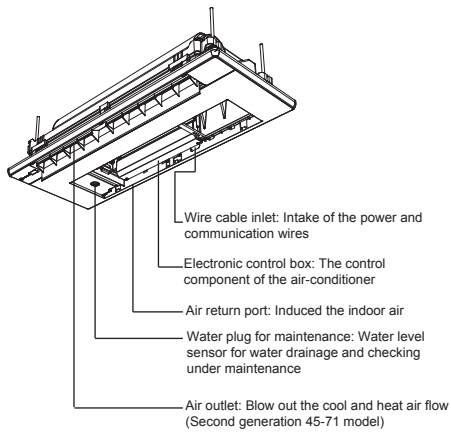

Figure 9.2

10. The Explain Of The Display Panel

The display panel has one type and the appearance of the type is shown in Figure 10.1.

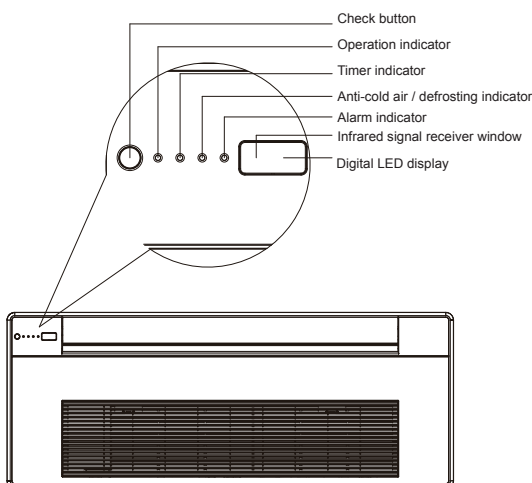

Figure 10.1

Table: Display panel output under normal operating conditions.

Unit state	Display output		
	Digital display panels		
	Unit state	Digital display	
Standby	Operation indicator flashes slowly		
Shutting-down	All indicators off		
Operation	Normal operation	Operation indicator on	Cooling and heating modes: set temperature Fan only mode: indoor ambient temperature
	Cold draft prevention or outdoor unit defrosting operation	Operation and Anti-cold / defrosting indicators on	Set temperature
A timer has been set		Timer indicator on	

11. Air Conditioner Operations and Performance

The operating temperature range under which the unit runs stably are given in below table.

Mode	Temperature	Indoor temperature
Cooling operation		17°C ~ 32°C
		Indoor Humidity Below 80%. Condensation will form on the surface with 80% humidity or above.
Heating operating (cooling only type without)		≤27°C

⚠ Note

- Using the unit outside of the accepted range may affect how it runs.
- Please close doors and windows if outside is humid to prevent condensation from forming on the unit.
- The unit performs best in this temperature range.
- The protection system is activated if abnormal conditions apply.

■ Please note the following correct operation for saving energy and achieve the quick and comfortable cooling/heating effect.

- **If the air filter is blocked, the cooling/heating effect is diminished.**
- **Close the door/window**
Do not let hot or cool air leak from the doors and windows.
- **Do not overcool or overheat.**
Avoid excessive exposure to cold air as it is not healthy. This applies especially to children, the elderly, and those with disabilities.
- **To maintain a comfortable temperature.**
Adjust the air-out direction using the air-out louver.

12. Adjusting Air Flow Direction

Because cold air flows down and hot air flows up, you can improve the cooling or heating and dispersal effect by adjusting the air flow louver direction.

⚠ Note

The heating operation with horizontal air outlet increases the difference of the room temperature.

The louver direction :

Choose horizontal outlet mode for cooling. Note the downward air flow will cause condensation on the air outlet and louver surface.

Adjust the Air Flow Direction Up and Down

● **Auto-swing**

Press SWING for the louver will swing up and down automatically.

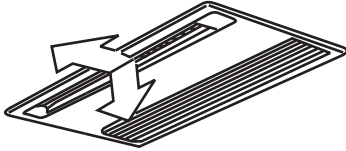

Figure 12.1

● **Manual swing**

Adjust the louver to improve the cooling or heating effect.

● **When cooling**

Adjust the louver horizontally.

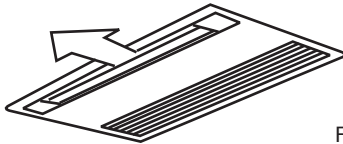

Figure 12.2

● **When heating**

Adjust the louver downwards (vertically).

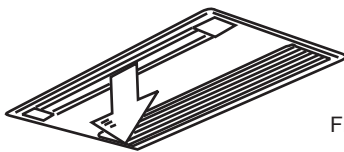

Figure 12.3

⚠ Caution

- 1 Water may drip from the surface of the unit or horizontal louver when cooling if the expel-air direction is vertically down.
- 2 The indoor temperature will not be even in heating mode when the air-out direction is horizontal.
- 3 Do not move the horizontal louver with hands or a malfunction may occur. Adjust it with the swing button on the wire controller.

13. Maintenance

⚠ Caution

- Please release pressure before disassembly.
- Before you clean the air conditioner, ensure it is powered off.
- Check that the wiring is undamaged and connected.
- Use a dry cloth to wipe the indoor unit and remote controller.
- A wet cloth may be used to clean the indoor unit if it is very dirty.
- Never use a damp cloth on the remote controller.
- Do not use a chemically treated duster on the unit or leave this type of material on the unit to avoid damaging the finish.
- Do not use benzene, thinner, polishing powder, or similar solvents for cleaning. These may cause the plastic surface to crack or warp.

◆ **Method for cleaning the air filter**

- a. The air filter can prevent the dust or other particles from entering the unit. If the filter is blocked, the unit will not work well. Clean the filter every two weeks when you use it regularly.
- b. If the air conditioner is positioned in a dusty place, clean the filter often.
- c. Replace the filter if it is too dusty to clean (the replaceable air filter is an optional fitting).

◆ **Take out the air-in grill**

Remove the air-in grille, hold the air-in buckle with two hands and open the grille downwards, Pull it to the inside, and push the filter buckle to remove the grille.

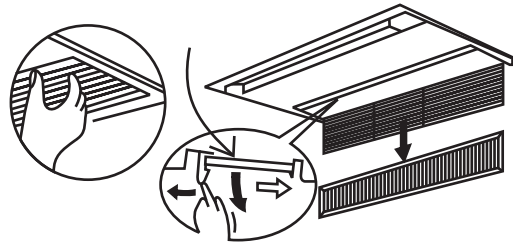

Figure 13.1

1. Dismantle the air filter.
2. Clean the air filter

Dusts will accumulate on the filter along with the unit operation, and need to be removed from the filter, or the unit would not function effectively.

Clean the filter every two weeks when you use the unit regularly. Clean the air filter with a vacuum cleaner or water.

- a. The air intake side should face up when using a vacuum cleaner. (Refer to Figure 13.2)
- b. The air intake side should face down when using clean water. (Refer to Figure 13.3)

For excessive dusts, use a soft brush and natural detergent to clean it and dry in a cool place.

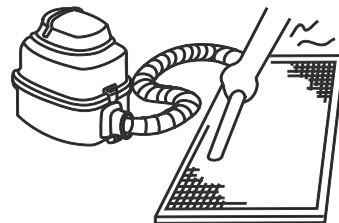

Figure 13.2

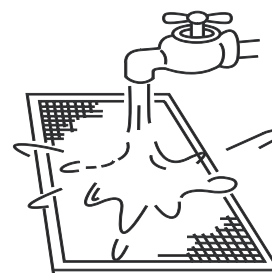



Figure 13.3

 **Caution**

- Do not dry out the air filter under direct sunshine or with fire.
- The air filter should be installed before the unit body installation.

3. Re-install the air filter.
 4. Install and close the air inlet grille by reversing steps 1 and 2, and connect the control box cables to the corresponding terminals in the main body.
- ♦ **Maintenance before stopping using the unit for a long time (e.g., at the end of a season)**
 - a. Let the indoor units run in fan only mode for about half a day to dry the interior of the unit.
 - b. Clean the air filter and indoor unit casing.
 - c. Refer to "Cleaning the air filter" for details. Install cleaned air filters back in their original positions.
 - d. Turn off the unit with the ON/OFF button on the remote controller, and then unplug it.

 **Caution**

- When the power switch is connected, some energy will be consumed even if the unit is not running. Disconnect the power to save energy.
- A degree of dirt will accumulate when the unit has been used several times, which will require cleaning.
- Take of the batteries from the remote controller.

- ♦ **Maintenance after a long period of non-use**
 - a. Check for and remove anything that might be blocking the inlet and outlet vents of the indoor units and outdoor units.
 - b. Clean the unit casing and clean the filter. Refer to [Cleaning the filter] and "Cleaning the filter" for instructions. Re-install the filter before running the unit.
 - c. Turn on the power at least 12 hours before you want to use the unit to ensure it works properly. As soon as the power is turned on, the remote control display appears.

14. Symptoms That Are Not Faults

The following symptoms may be experienced during the normal operation of the unit and are not considered faults. Note: If you are not sure whether a fault has occurred, contact your supplier or service engineer immediately.

Symptom 1: The unit will not run

- ♦ **Symptom:** When the ON/OFF button on the remote controller is pressed, the unit does not immediately start running.
Cause: to protect certain system components, system start-up or re-start is intentionally delayed for up to 12 minutes under some operating conditions. If the OPERATION LED on the unit's panel is lighting, the system is working normally and the unit will start after the intentional delay is complete.
- ♦ Heating mode is running when the following panel lights are on: operation and the "DEF./FAN LED indicator."
Cause: the indoor unit activates protective measures because of the low outlet temperature.

Symptom 2: The unit emits white mist

- ♦ White mist is generated and emitted when the unit starts to operate in a very humid environment. This phenomenon will stop once the humidity in the room is reduced to normal levels.
- ♦ The unit occasionally emits white mist when it runs in heating mode. This occurs when the system finishes periodic defrosting. Moisture that may accumulate on the unit's heat exchanger coil during defrosting becomes mist and is emitted from the unit.

Symptom 4: Dust is emitted from the unit

- ♦ This can occur when the unit first runs after a long idle period.

Symptom 5: The unit gives off a strange odor

- ♦ If smells such as those of strong-smelling food or tobacco smoke are present in the room, they can enter the unit, leave trace deposits on the unit's internal components, and later be emitted from the unit.

15. Troubleshooting

15.1 General

- ♦ Sections 15.2 and 15.3 describe some initial troubleshooting steps that can be taken when an error occurs. If these steps do not resolve the issue, arrange for a professional technician to investigate the problem. Do not attempt further investigations or troubleshooting yourself.
- ♦ If any of the following errors occur, power the unit off, contact a professional technician immediately and do not attempt troubleshooting yourself:
 - a. A safety device such as a fuse or circuit breaker frequently blows/trips.
 - b. An object or water enters the unit.
 - c. Water is leaking from the unit.

 **Caution**

- Do not attempt to inspect or repair this unit by yourself. Arrange for a qualified technician to carry out all servicing and maintenance.

15.2 Unit Troubleshooting

Symptom	Possible causes	Troubleshooting steps
The unit does not start	A power cut has occurred (the power to the premises has been cut-off).	Wait for the power to come back on.
	The unit is powered off.	Power on the unit. This indoor unit forms part of an air conditioning system that has multiple indoor units that are all connected. The indoor units cannot be powered on individually - they are all connected to one, single power switch. Ask a professional technician for advice regarding how to safely power on the units.
	The power switch fuse may have burned out.	Replace the fuse.
	The remote controller's batteries are dead.	Replace the batteries.
Air flows normally but doesn't cool	The temperature setting is not correct.	Set the desired temperature on the remote controller.
The unit starts or stops frequently	Arrange for a professional technician to check the following: <ul style="list-style-type: none"> ◆ Too much or too little refrigerant. ◆ No gas in the refrigerant circuit. ◆ The outdoor unit compressors have malfunctioned. ◆ The power supply voltage is too high or too low. ◆ There is a blockage in the piping system. 	
Low cooling effect	Doors or windows are open.	Close the doors and windows.
	Sunlight is shining directly onto the unit.	Close shutters/blinds to shield the unit from direct sunlight.
	The room contains many heat sources such as computers or refrigerators.	Turn off some of the computers during the hottest part of the day.
	The unit's air filter is dirty.	Clean the filter.
	The outside temperature is unusually high .	The cooling capacity of the system reduces as the outdoor temperature rises and the system may not provide sufficient cooling if the local climate conditions are not considered when the system's outdoor units were selected.
	Engage a professional air conditioning engineer to check the following: <ul style="list-style-type: none"> ◆ The unit's heat exchanger is dirty. ◆ The unit's air inlet or outlet is blocked. ◆ A refrigerant leak has occurred. 	
Low heating effect	Doors or windows are not completely closed.	Close doors and windows.
	Arrange for a professional technician to check the following: A refrigerant leak has occurred.	

15.3 Remote Controller Troubleshooting

Warning:

Certain troubleshooting steps that a professional technician may perform when investigating an error are described in this owner's manual for reference only. Do not attempt to undertake these steps yourself – arrange for a professional technician to investigate the problem.

If any of the following errors occur, power the unit off and contact a professional technician immediately. Do not attempt troubleshooting yourself:

- ◆ A safety device such as a fuse or circuit breaker frequently blows/trips.
- ◆ An object or water enters the unit.
- ◆ Water is leaking from the unit.

Symptom	Possible causes	Troubleshooting steps
The fan speed cannot be adjusted	Check whether the MODE indicated on the display is "AUTO".	In automatic mode, the air conditioner will automatically change the fan's speed.
	Check whether the MODE indicated on the display is "DRY".	When dry mode is selected, the air conditioner automatically adjusts the fan speed. (The fan speed can be selected during "COOL", "FAN ONLY", and "HEAT".)
The remote controller signal is not transmitted even when the ON/OFF button is pushed	A power cut has occurred (the power to the premises has been cut-off).	Wait for the power to come back on.
	The remote controller's batteries are dead.	Replace the batteries.
The indication on the display disappears after a certain time	Check whether the timer operation has come to an end when TIMER OFF is indicated on the display.	The air conditioner operation will stop up to the set time.
The TIMER ON indicator goes off after a certain time	Check whether the timer operation has come to an end when TIMER ON is indicated on the display.	Up to the set time, the air conditioner will automatically start and the appropriate indicator will go off.
No receiving sound from the indoor unit when the ON/OFF button is pressed	Check whether the signal transmitter of the remote controller is properly directed to the infrared signal receiver of the indoor unit when the ON/OFF button is pressed.	Directly transmit the signal transmitter of the remote controller to the infrared signal receiver of the indoor unit, and then press the ON/OFF button twice.

15.4 Error Codes

With the exception of a mode conflict error, contact your supplier or service engineer if any of the error codes listed in the following table are displayed on the unit's display panel. If the mode conflict error is displayed and persists, contact your supplier or service engineer. These errors should only be investigated by a professional technician. The descriptions are provided in this manual for reference only.

Content	Digital display output	Possible causes
Mode conflict	E0	<ul style="list-style-type: none"> ◆ The indoor unit's operating mode conflicts with that of the outdoor units.
Communication error between indoor and outdoor units	E1	<ul style="list-style-type: none"> ◆ Communication wires between indoor and outdoor units not connected properly. ◆ Interference from high voltage wires or other sources of electromagnetic radiation. ◆ Communication wire too long. ◆ Damaged main PCB.
Indoor ambient temperature sensor (T1) error	E2	<ul style="list-style-type: none"> ◆ Temperature sensor not connected properly or has malfunctioned. ◆ Damaged main PCB.
Indoor heat exchanger mid-point temperature sensor (T2) error	E3	
Indoor heat exchanger outlet temperature sensor (T2B) error	E4	
Fan error	E6	<ul style="list-style-type: none"> ◆ Fan stuck or blocked. ◆ Fan motor not connected properly or has malfunctioned. ◆ Power supply abnormal. ◆ Damaged main PCB.
EEPROM error	E7	<ul style="list-style-type: none"> ◆ Damaged main PCB.
Indoor EEV coil error	Eb	<ul style="list-style-type: none"> ◆ Line loosened or broken. ◆ The electronic expansion valve is stuck. ◆ Damaged main PCB.
Outdoor unit error	Ed	<ul style="list-style-type: none"> ◆ Outdoor unit error.
Water level error	EE	<ul style="list-style-type: none"> ◆ Water level float stuck. ◆ Water level switch not connected properly. ◆ Damaged main PCB. ◆ Drain pump has malfunctioned.
The indoor unit has not been assigned an address	FE	<ul style="list-style-type: none"> ◆ Indoor unit has not been assigned an address.

Notes:

Flashing rapidly means flashing twice per second; flashing slowly means flashing once per second.

Wiring Diagram

Model: Q1DN-2-XMi D18 - Q1DN-2-XMi D22 - Q1DN-2-XMi D28 - Q1DN-2-XMi D36

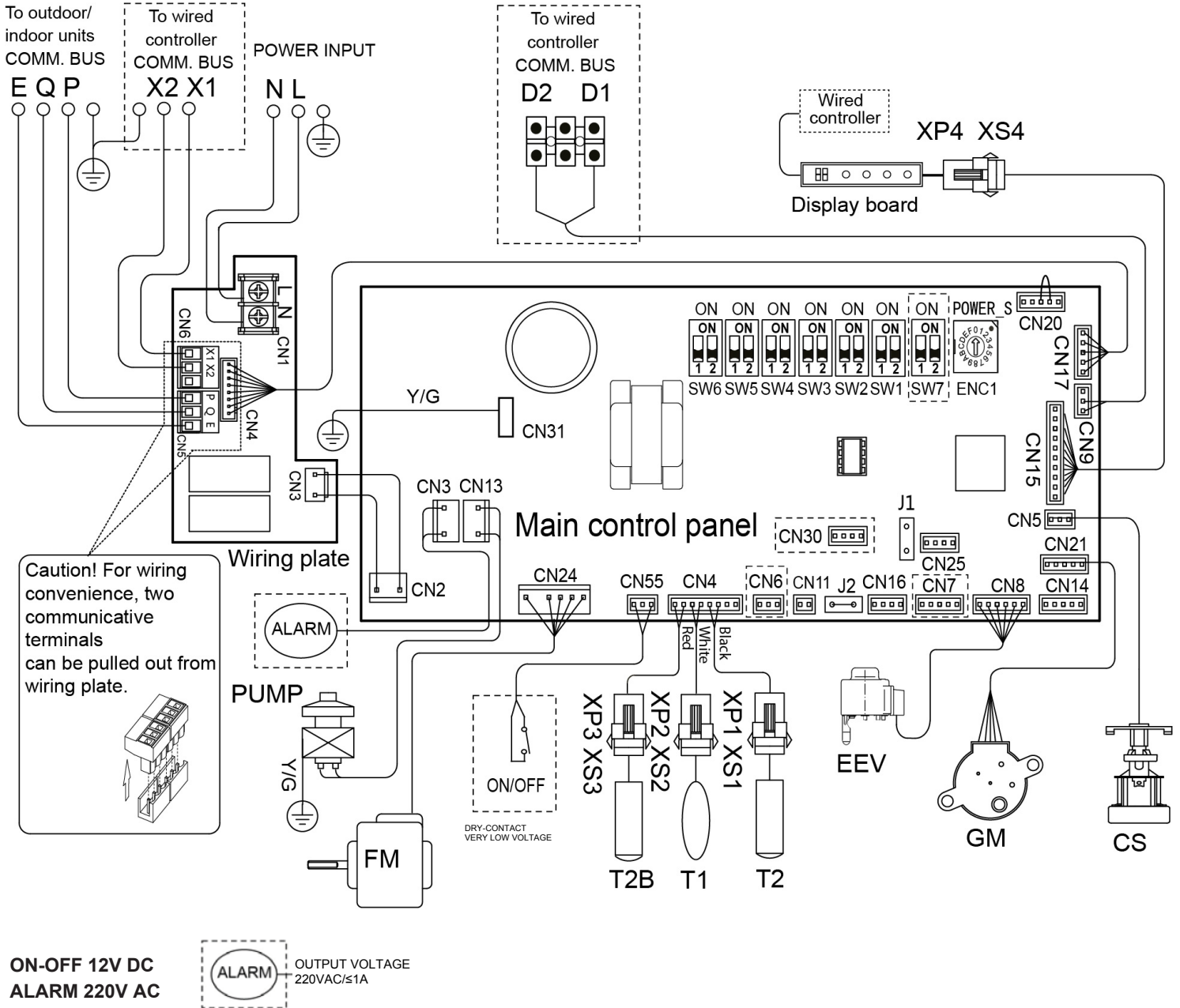

HP set switch ENC1 definition list		Code	Name
Code	Indoor unit capacity value	FM	Indoor fan motor
0	1800W	GM	Swinging motor
0	2200W	PUMP	Water drainage pump
1	2800W	CS	Water level sensor
2	3600W	EEV	Electronic expansion valve
3	4500W	T1	Indoor ambient temp. sensor
4	5600W	T2	Indoor heat exchanger mid-point temp. sensor
5	7100W	T2B	Indoor heat exchanger outlet temp. sensor
		XP1-4	Connectors
		XS1-4	Connectors

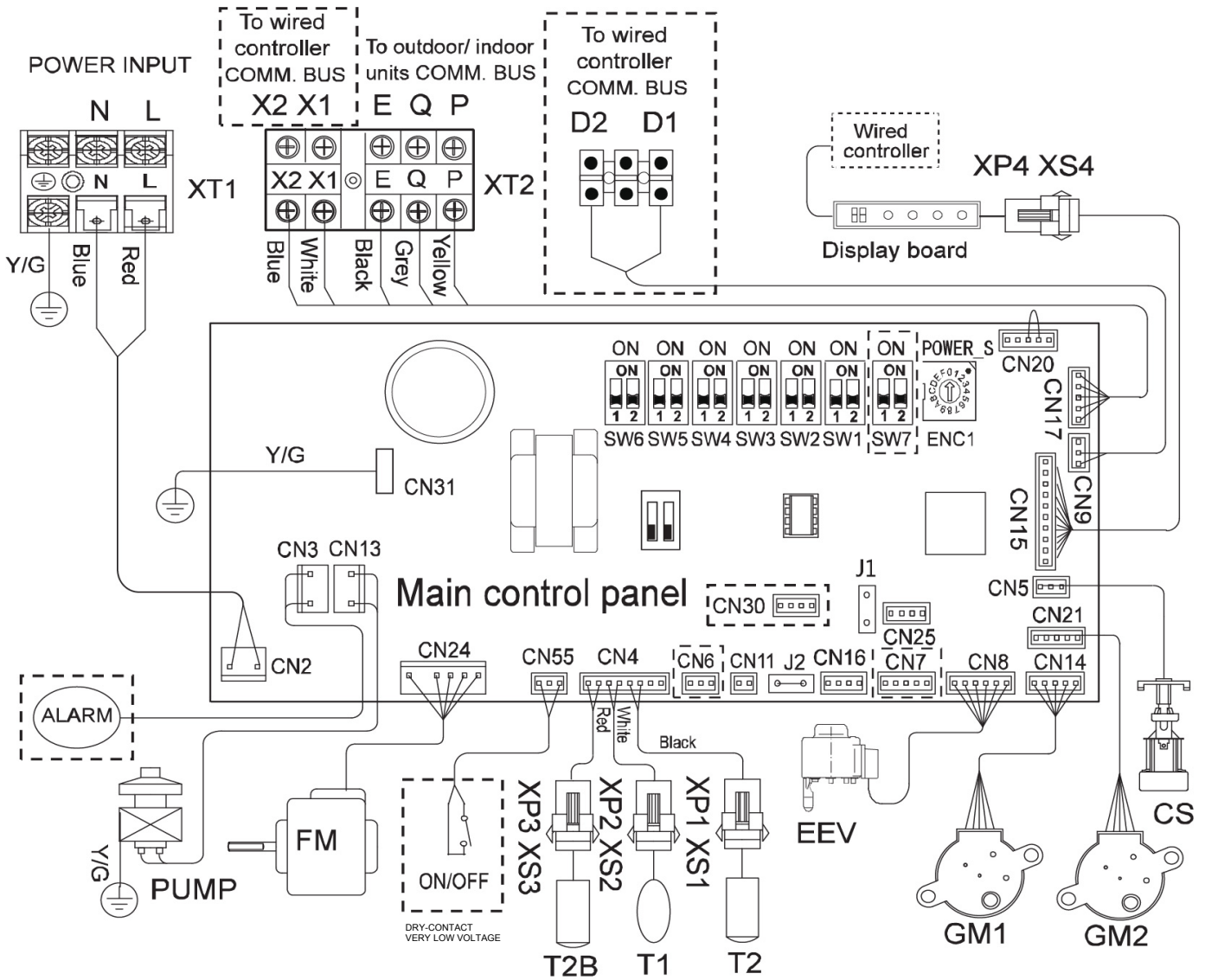

ON-OFF 12V DC
ALARM 220V AC

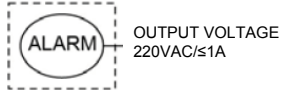

HP set switch ENC1 definition list		Code	Name
Code	Indoor unit capacity value	FM	Indoor fan motor
0	1800W	GM1-2	Swinging motor
0	2200W	PUMP	Water drainage pump
1	2800W	CS	Water level sensor
2	3600W	EEV	Electronic expansion valve
3	4500W	T1	Indoor ambient temp. sensor
4	5600W	T2	Indoor heat exchanger mid-point temp. sensor
5	7100W	T2B	Indoor heat exchanger outlet temp. sensor
		XP1-4	Connectors
		XS1-4	Connectors
		XT1-2	Terminal

REVISIONS

ELECTRICAL WIRING

Premise:

In order to be sure that the automatic addressing will end successfully please respect the following suggested timings.

ODU: Outdoor unit

IDU: Indoor unit

Procedure for M5 e Mini VRF (sizes from 200T to 450T):

1. Power off all the ODUs and all the IDUs;
2. On the ODU (only on the Master in case of multiple ODUs), set the S6 switch on «Clean indoor units addresses»;
3. Check that all the switches on the S7 are in OFF position (ONLY for 400T and 450T sizes);
4. Power on all the IDUs and wait at least for 20 seconds;
5. Power on all the ODUs and wait at least for 60 seconds;
6. Power off only the ODUs and wait at least for 60 seconds;
7. Ended the point 6, set the S6 switch in «Auto Addressing» position and then power on the ODUs;
8. Wait the end of the automatic addressing: the operation will be completed when all the IDUs will display the "OPERATION" led blinking slowly and, if the IDUs are equipped with display, the two fixed indents «--»;
9. Finish.

Procedure for MV6:

1. Power off all the ODUs and all the IDUs;
2. Set the IDUs number on the rotary switch ENC3 and the dip-switch S12 using the description on the wiring diagram (paste on the cover of the electrical box) or on the Service Manual available on the Clivet Portal;
3. On the ODU (only on the Master in case of multiple ODUs), set the S6 switch on «Clean indoor units addresses»;
4. Power on all the IDUs and wait at least for 20 seconds;
5. Power on all the ODUs and wait at least for 60 seconds;
6. Power off only the ODUs and wait at least for 60 seconds;
7. Ended the point 6, set the S6 switch in «Auto Addressing» position and then power on the ODUs;
8. Wait the end of the automatic addressing: the operation will be completed when all the IDUs will display the "OPERATION" led blinking slowly and, if the IDUs are equipped with display, the two fixed indents «--»;
9. Finish.

Procedure for Mini VRF (sizes from 80M to 180T)

The sizes from 80M to 105M have the SW3 (dip with 2 switches):

The sizes from 120M to 160M have the SW1 (dip with 3 switches):

The sizes from 120T to 180T have the SW7 (SW3) (dip with 2 switches):

1. Power off all the ODUs and all the IDUs;
2. On the ODU, set the switch SW3 (or SW1) on «Revocation indoor unit network address»;
3. Power on all the IDUs and wait at least for 20 seconds
4. Power on the ODU and wait at least for 60 seconds;
5. Power off only the ODU and wait at least for 60 seconds;
6. Ended the point 5, set the SW3 (or SW1) on «Obtain network address automatically» and then power on the ODU;
7. Wait the end of the automatic addressing: the operation will be completed when all the IDUs will display the "OPERATION" led blinking slowly and, if the IDUs are equipped with display, the two fixed indents «--»;
8. Finish.

INFORMATIVE TIP

The outdoor units Mini VRF // M5 // MV6 // MW (water source) series, dispose of the possibility to address MANUALLY or AUTOMATICALLY the indoor units.

The outdoor units MHR series (3 pipes heat recovery system) only dispose of the possibility to address MANUALLY the indoor units.

HOW to carry out the MANUAL addressing and WHEN use it:

Always, on the system with outdoor unit MHR series (3 pipes heat recovery system);

The manual addressing allows the user to set a specific address (from 0 to 63) to the main PCB of an indoor unit.

If the wired-controller or the wireless controller dispose of "addressing" function, it's necessary to carry out the procedure written on the controller manual :each controller has its procedure.

[1] It's advisable, but NOT strictly necessary, to carry out the addressing with a consecutive numbering (starting from 0).

[2] If there are more VRF systems to connect at a single centralized, it's MANDATORY that all the indoor units have their addresses different from each other (indoor units with the same address are NOT permitted);

WARNING:

If the VRF system is connected to a centralized controller (ex: CCM09 // CCM30 // CCM15) it's MANDATORY setting the address-dip-switch on the outdoor unit in AUTOMATIC position.

Power-off and power-on the system.

This will NOT modify the set address of the indoor units (neither powering off/on the system): it's only a modify of the dip-switch position.

HOW to carry out the AUTOMATIC addressing and WHEN use it:

With the automatic addressing the outdoor unit assigns arbitrarily an address (always a progressive number from 0 to n-1) at each of the n indoor units main PCBs;

The automatic addressing CAN be modified subsequently MANUALLY always leaving the addressing dip-switch of the outdoor unit in AUTOMATIC position.

Real case (example):

- a system equipped with 23 indoor units is addressed automatically;
- the set addresses start from 0 to 22;
- the user want to set a set the address 63 to a specific indoor unit (in order to use the VIP function);
- it is possible to carry out the manual addressing (as explained in the previous topic) WITHOUT modify the addressing dip-switch of the outdoor unit (leave it in AUTOMATIC).
- Power-off and power-on the system.

We advise to use this type of addressing on a single VRF system.

ELECTRICAL WIRING

The type of cable used for RS 485 communication, if not suitable for such use, can compromise the packets transmission.

For the specific case, it requires a 3-wire+ shield cable for the RS 485 type transmission.

A suitable type of cable for this activity is surely Belden in the annex.

Attention: the type of cable used must be checked for "type of data transmitted" according to the installation where it will be placed too.

Following some key-point that must be respect in order to get the best communication performance:

Shield connection:

- The serial cable shield must be connect to a noise-free ground.
- The shield must be connect to the ground at one point only.
- The continuity of the screen must be provide throughout the extension of the serial cable.

NB: These provisions are generally valid. In some areas characterized by the presence of particular types of coupling of electromagnetic disturbances, a different type of screen connection may be necessary.

General prescriptions:

- The cable must have insulation and voltage characteristics in accordance with current electrical standards.
- The insulation of the cable must have characteristics of non-propagation of the flame or fire, commensurate with the reference electrical standards for the type of system on which it is place.
- The cable must be place according to the rules of the art rule.
- The cable must be place separately with respect to other cables, especially if they are power cables or powered at different voltages
- The cable must be place away from cables or devices that can induce electromagnetic noise.
- The RS485 serial line must be make in "Bus topology – hand by hand". Different topologies are not allowed (ring, star etc.)
- The serial line must be place by trained and experienced electricians in data communication networks.

Network port of the VRF system - RS485 interface

+	+	GND
X	Y	E
K1	K2	E
P	Q	E
F1	F2	E
A1	B1	E
A2	B2	E
H1	H2	E
A	O	E

WATER DISCHARGE PIPING INSTALLATION

The pump works always when the IDU is ON and in COOLING mode;

If the unit is working in another mode or it is OFF, the pump is OFF but, in case of water level switch intervention, it is switch ON.

5.4.5 Connecting VRF piping assembly



Caution

- The wrong installation will cause the unit to malfunction.

The branch joints should be as level as possible, and the angular error does not exceed 10°.

U type branch joint

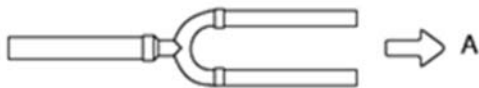

A-direction view

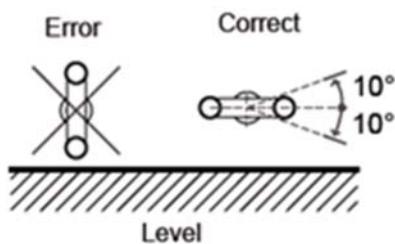

Figure 5.8

Page intentionally left blank

WE DECLARE UNDER OUR SOLE RESPONSIBILITY THAT THE MACHINE

DICHIARIAMO SOTTO LA NOSTRA SOLA RESPONSABILITÀ CHE LA MACCHINA
 WIR ERKLÄREN EIGENVERANTWORTLICH, DASS DIE MASCHINE
 NOUS DÉCLARONS SOUS NOTRE SEULE RESPONSABILITÉ QUE LA MACHINE
 EL FABRICANTE DECLARA BAJO SU EXCLUSIVA RESPONSABILIDAD QUE LA MÁQUINA

CATEGORY DIRECT EXPANSION TERMINALS - Heat pump
 CATEGORIA **TERMINALI AD ESPANSIONE DIRETTA - Pompa di calore**
 KATEGORIE **DIREKTVERDAMPFUNGSGERÄTE - Wärmepumpe**
 CATEGORIE **TERMINAUX À DÉTENTE DIRECTE - Pompe à chaleur**
 CATEGORIA **TERMINALES POR EXPANSIÓN DIRECTA - Bomba de calor**

TYPE / TIPO / TYP / TYPE / TIPO

MODEL	MODEL
Q1DN-2-XMi D18	Q1DN-2-XMi D45
Q1DN-2-XMi D22	Q1DN-2-XMi D56
Q1DN-2-XMi D28	Q1DN-2-XMi D71
Q1DN-2-XMi D36	

- **COMPLIES WITH THE FOLLOWING EC DIRECTIVES, INCLUDING THE MOST RECENT AMENDMENTS, AND THE RELEVANT NATIONAL HARMONISATION LEGISLATION CURRENTLY IN FORCE:**
- RISULTA IN CONFORMITÀ CON QUANTO PREVISTO DALLE SEGUENTI DIRETTIVE CE, COMPRESSE LE ULTIME MODIFICHE, E CON LA RELATIVA LEGISLAZIONE NAZIONALE DI RECEPIMENTO:
- DEN IN DEN FOLGENDEN EG-RICHTLINIEN VORGEGEHENEN VORSCHRIFTEN, EINSCHLIEßLICH DER LETZTEN ÄNDERUNGEN, SOWIE DEN ANGEWANDTEN LANDESGESETZEN ENTSPRICHT:
- EST CONFORME AUX DIRECTIVES CE SUIVANTES, Y COMPRIS LES DERNIÈRES MODIFICATIONS, ET À LA LÉGISLATION NATIONALE D'ACCUEIL CORRESPONDANTE:
- ES CONFORME A LAS SIGUIENTES DIRECTIVAS CE, INCLUIDAS LAS ÚLTIMAS MODIFICACIONES, Y A LA RELATIVA LEGISLACIÓN NACIONAL DE RECEPCIÓN:

- 2006/42/EC** **machinery directive**
 direttiva macchine
 Maschinenrichtlinie
 directive sur les machines
 directiva máquinas
- 2014/30/UE** **electromagnetic compatibility**
 compatibilità elettromagnetica
 Elektromagnetische Verträglichkeit
 compatibilité électromagnétique
 compatibilidad electromagnética
- 2009/125/CE** **Ecodesign /Progettazione ecocompatibile / Ecodesign / Éco-conception / Ecodiseño**
- 2011/65/UE** **RoHs**

-Unit manufactured and tested according to the followings Standards:
 -Unità costruita e collaudata in conformità alle seguenti Normative:
 -Unité construite et testée en conformité avec les Réglementations suivantes
 -Unidad construida y probada de acuerdo con las siguientes Normativas
 -Gebautes und geprüftes Gerät nach folgenden Normen

EN 60335-1 :2012/A13 :2017 EN 60335-2-40 :2003/A13 :2012
 EN 62233 :2008 EN 61000-6-1 :2007 EN 61000-6-3 :2007/A1 :2011
 EN 62321-1 :2013 EN 62321-2 :2014 EN 62321-3-1 :2014
 EN 62321-4 :2014 EN 62321-5 :2014 EN 62321-6 :2015
 EN 62321-7-1 :2015 EN 62321-7-2 :2017 EN 62321-8 :2017

-Responsible to constitute the technical file is the company n°00708410253 and registered at the Chamber of Commerce of Belluno Italy
 -Responsabile a costituire il fascicolo tecnico è la società n° 00708410253 registrata presso la Camera di Commercio di Belluno Italia
 -Verantwortliche für die technischen Unterlagen zusammenstellen n°00708410253 ist das Unternehmen bei der Handelskammer von Belluno Italien registriert
 -Responsable pour compiler le dossier technique est la société n°00708410253 enregistrée à la Chambre de Commerce de Belluno en Italie
 -Encargado de elaborar el expediente técnico es la empresa N ° 00708410253 registrada en la Cámara de Comercio de Belluno Italia

NAME / NOME / VORNAME / PRÉNOM / NOMBRE
 SURNAME / COGNOME / ZUNAME / NOM / APELLIDOS



STEFANO
 BELLÒ

FELTRE, 29/10/2018

COMPANY POSITION / POSIZIONE / BETRIEBSPOSITION / FONCTION / CARGO LEGALE RAPPRESENTANTE

FOR OVER 30 YEARS, WE HAVE
BEEN OFFERING SOLUTIONS TO
ENSURE SUSTAINABLE COMFORT
AND THE WELL-BEING OF PEOPLE
AND THE ENVIRONMENT

www.clivet.com

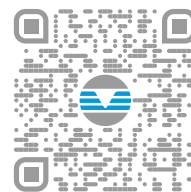

sales and assistance



CLIVET SPA

Via Camp Lonc 25, Z.I. Villapaiera
32032 Feltre (BL) - Italy
Tel. +39 0439 3131 - Fax +39 0439 313300
info@clivet.it

A Group Company of

