



4-WAY CASSETTE

Q4DN-2-XMi series D28÷D140

MANUAL
FOR INSTALLATION,
USE AND MAINTENANCE



MOVY00002-01 - 12/2020

INTRODUCTION

Dear Customer,

Thank you for choosing a **CLIVET** product.

The model which you have chosen is a high performance product of advanced design and technology, high reliability and quality construction.

We suggest that you entrust its management and maintenance to professionally qualified personnel you trust, who, when necessary, only use original spare parts.

This manual contains important information and tips that must be followed for easier installation and the best possible use of the appliance.

SERIES

VRF systems	
4-WAY CASSETTE unit	from D28 to D140

SYMBOLS USED IN THE MANUAL AND THEIR MEANING



WARNING

To indicate special information.



CAUTION

To indicate particularly important and delicate operations.



CAUTION DANGER

To indicate actions which, if not carried out correctly, may result in general accidents or may cause malfunctions or material damage to the appliance; therefore, they require special attention and adequate preparation.



ATTENTION ELECTRIC DANGER

To indicate actions which, if not carried out correctly, may result in accidents of electrical origin; therefore, they require special attention and adequate preparation.



IT IS PROHIBITED TO

indicate actions that **MUST NOT** be performed.

WARRANTY

The product **CLIVET** is covered by a **conventional warranty**, valid from the date of purchase of the appliance, the conditions of which are specified in the GENERAL CONDITIONS OF SALE available at www.clivet.com



WARNING

- The warranty is void if the appliance has been used without following the instructions in this manual.
- The warranty will be forfeited if the customer makes changes and/or attempts to repair the product himself or through third parties not authorised by the manufacturer/authorised dealer.
- The product must be intended for the use intended by **CLIVET** for which it was expressly made. Any contractual and non-contractual liability **CLIVET** for damage caused to persons, animals or property by installation, adjustment, maintenance and misuse errors is excluded.

INDEX

1	General Details	4	6	Use.....	32
1.1	General warnings and safety rules	4	6.1	Description of system components	32
1.2	Description of system components	8	6.2	Operation	33
1.3	Accessories	9	6.2.1	Meaning of the display codes	33
1.4	Identification	9	6.3	Other functions	33
2	Installation	10	6.4	Airflow angle control	34
2.1	Product receiving	10	7	Maintenance.....	35
2.2	Size and weight	10	7.1	Cleaning the indoor unit	35
2.3	Installation - preliminary warnings	10	7.2	Cleaning the air filter	35
2.4	Installation	11	7.3	Extended periods of inactivity	36
2.4.1	Installation room	11	7.4	Maintenance at the start of the season	36
2.4.2	Hang the indoor unit	14	7.5	Troubleshooting	37
2.4.3	Derived ducts	17	7.5.1	Common problems	37
2.4.4	Preparation for connection pipes	18	7.5.2	Anomalies and remedies	38
2.4.5	Drainage pipe	18	7.6	Indoor unit error codes	39
3	Electrical connections.....	21	8	Disposal	40
3.1	Preliminary information	21	9	Attachments	41
3.2	Power cable connection	22	9.1	Indoor unit wiring diagrams	41
3.2.1	Electrical wiring specifications	22	9.2	Declaration of conformity	43
3.3	Communication wiring	23			
3.3.1	Communication wiring between the indoor and outdoor units	24			
3.3.2	Communication wiring between the indoor unit and the wired controller	24			
3.4	Assembling the panel	26			
4	Configuration	29			
4.1	Power setting	29			
4.2	Address setting	29			
4.3	DIP Switch settings on main board	30			
5	Running the test	31			
5.1	Checks to perform before running the test	31			
5.2	Running the test	31			

Section dedicated to the USER

1 GENERAL DETAILS

1.1 General warnings and safety rules



WARNING

- This manual is the property of CLIVET and reproduction or transfer to third parties of the contents of this document is prohibited. All rights reserved. It is an integral part of the product; make sure that it is always supplied with the appliance, even in case of sale/transfer to another owner, so that it can be consulted by the user or by personnel authorised to carry out maintenance and repairs.
- Read this manual carefully before using the appliance to ensure its safe operation.
- Periodically check the integrity of the power cable. If the power cable is damaged, it may only be replaced by the manufacturer or the local distributor who sold the appliance or by authorised maintenance and repair personnel.
- Installation must be in accordance with the IEC 61000-3-12 standard.
- The installation must be carried out by an authorised dealer or a qualified technician. Incorrect installation may cause water leakage, electric shock and fire, or cause the appliance to malfunction.
- The installation must be carried out according to the instructions provided. An incorrect installation may cause water leaks, electric shock or fire.
- Perform the installation using only the supplied accessories and parts specified. The use of non-standard components may cause water leakage, electric shock or fire and cause the unit to malfunction.
- Work on the refrigerant circuit must only be carried out by persons with a valid certification, issued by an accredited body, certifying their competence to handle refrigerants safely in compliance with the specifications in force in the sector.
- Use a vacuum pump with a non return valve to evacuate the system. Do not perform an air purge using refrigerant.
- Use deoxidised phosphorous copper piping for the refrigerant (seamless copper alloy piping and tubing). Keep the inner and outer surface of the pipes clean and free of contaminants.
- Store the piping indoors and keep both ends of the pipes sealed until it is time to flare or weld.
- Do not use any means other than those recommended by the manufacturer to accelerate the defrosting process or to clean the unit.
- The appliance must be placed in a room that does not contain any ignition sources (e.g. open flames, gas appliances or electric heaters).
- Weld the pipes purging with nitrogen to avoid oxidation.
- Keep the interconnection cable away from the copper pipe. The temperature of the refrigerant circuit is high.
- Note that the refrigerants are odourless.
- Use only the refrigerants indicated in the manual.
- Recharge the refrigerant when it is in the liquid state.
- After installation, verify that there are no refrigerant leaks.
- Do not touch the components of the refrigerant line during or immediately after operation of the appliance. There is a risk of burns or frostbite.
- Install the connection joints and manifolds referring to the installation manual.
- Install the drainage pipe according to the instructions in this manual. Incorrect draining can cause water seepage or flooding with possible damage to the home and other property.
- Insulate the piping to avoid condensation.

- Always use the specified cables for all electrical work. Connect the cables securely and secure them in a stable manner to prevent the terminals from being damaged by external forces. Incorrect electrical connection may cause overheating conditions and may result in fire and electrocution.
- Install the electrical cables making sure that they are not taut. Otherwise, they could break or overheat causing smoke or fire.
- The cables must be arranged so that the control board cover can close properly. If the control board cover is not closed properly, corrosion may occur and the connection points on the terminals may become hot, ignite or cause electric shock.
- Always disconnect all power supply circuits before touching the terminals for any reason.
- It is advisable to install a Class B or F differential magnetothermic circuit breaker on the power supply line of the appliance.
- For electrical work, comply with the provisions of the national electrical code, local regulations, current regulations and the requirements contained in the installation manual. It is necessary to use an independent circuit and a single power supply socket. Do not connect other appliances to the same electrical outlet. Insufficient electrical capacity or faulty electrical installation may cause risk of electric shock or fire.
- Incorporate in the wiring an omnipolar isolator switch with a separation distance of at least 3mm between all poles and a residual current device (RCD) with a value greater than 10mA. Observe the domestic regulations.
- Replace the fuses only with others of the same value and technical characteristics.
- Install the appliance and its power cables at least one metre away from other electrical equipment in order to avoid interference or noise.
- The appliance must be stored in such a way as to prevent any mechanical damage.
- Consult a qualified technician for unit repair or maintenance.
- Do not modify or alter the safety or protection devices.
- Do not touch the appliance with wet or damp parts of the body as to do so could lead to electric shock.
- Make sure that the power is disconnected before performing any service or maintenance.
- If you notice any anomalies (e.g. a burning smell), stop the appliance, turn off the power switch and consult your dealer.
- Make sure that the air inlet and outlet are not blocked as this could trigger the protective device that stops the appliance.
- This appliance is intended for use on commercial premises by experienced or suitably trained users
- This appliance is designed to cool or heat spaces intended for the presence of human beings. It must not be used to cool or heat food, plants, animals, machinery, equipment or works of art.
- Read this manual carefully before using the appliance to ensure its safe operation.

**CAUTION DANGER**

- When connecting refrigerant piping, keep substances or gases other than the specified refrigerant from entering the unit. The presence of other gases or substances can reduce unit performance and cause an abnormal increase in pressure in the refrigeration cycle. This can lead to explosion hazards and resulting injuries.
- Install the unit on a stable stand that can support its weight. If the chosen stand cannot support the weight of the unit, or if the installation is not performed correctly, the unit may fall and cause injury and serious damage.
- Do not pierce or ignite the appliance.
- The appliance must be placed in a well-ventilated room whose dimensions correspond to those specified for operation.
- The product must be installed with earthing in accordance with the law to avoid the risk of electrocution. Do not connect the earth cable to gas or water mains, lightning rods or phone earth cables.
- Install an earthing connection switch. Failure to install this can result in electric shock.
- Do not operate the appliance if the protections have been removed.
- Do not install the unit:
 - in a location that can be exposed to combustible gas leaks. Any accumulation of combustible gas around the unit may cause a fire hazard;
 - near the coast (except in the case of corrosion resistant models);
 - near a source of hot water due to the presence of caustic gas in the air;
 - in the presence of strong electromagnetic waves;
 - in the presence of significant voltage flicker;
 - in the presence of acid or alkaline liquid that evaporates;
 - in the presence of flammable materials or gas.
- Wear the required PPE (protective gloves) during installation and maintenance. High pressure piping poses a risk of burns during operation.
- Measure the insulation resistance and make sure it is at least $1M \Omega$ once the wiring work is done.
- Do not use flammable paints, enamels, sprays or other products that may release flammable fumes or vapours near the appliance as they could cause fires.
- Do not install open flame units near the appliance. The heat released could ruin it.
- Do not insert your fingers between the fans during operation. This could lead to injury.
- Do not allow children to play near the unit as it may cause injury.



IT IS PROHIBITED TO

- Make changes and/or repair attempts to the product. Any repairs must be carried out by a qualified technician.
- Touch the appliance with wet, damp and/or barefoot body parts. If you notice current leakage that can be detected on contact with metal parts of the appliance, disconnect the switch, unplug it from the power supply socket and contact an authorised dealer.
- Disperse in the environment and leave within the reach of children the packaging material as it may be a potential source of danger. It must therefore be disposed of in accordance with current legislation.
- Use the same electrical outlet for other appliances. Incorrect or insufficient power supply may cause fire or electric shock hazard.
- Connect the electric air conditioner to the power supply before having finished wiring the power lines and pipes. Connect the cables of the outdoor unit and then those of the indoor unit.
- Perform maintenance in the rain. Electrical leakage, electric shock, short circuit, malfunction, smoke or fire may occur.



Notes on fluorinated gases

- This air conditioner contains fluorinated gas. For specific information on gas types and quantities, please refer to the plate found on the unit. It is always necessary to comply with national regulations regarding the use of gases.
- Installation, service, maintenance and repair of the unit must be performed by a qualified technician.
- The uninstallation and recycling of the product must be carried out by qualified technical personnel.
- If a leak detection device is installed in the system, it is necessary to check that there are no leaks at least every 12 months. When checking the unit for leaks, it is recommended to keep a detailed record of all inspections.
- Pay attention to the fact that refrigerant R410A is odourless.

1.2 Description of system components

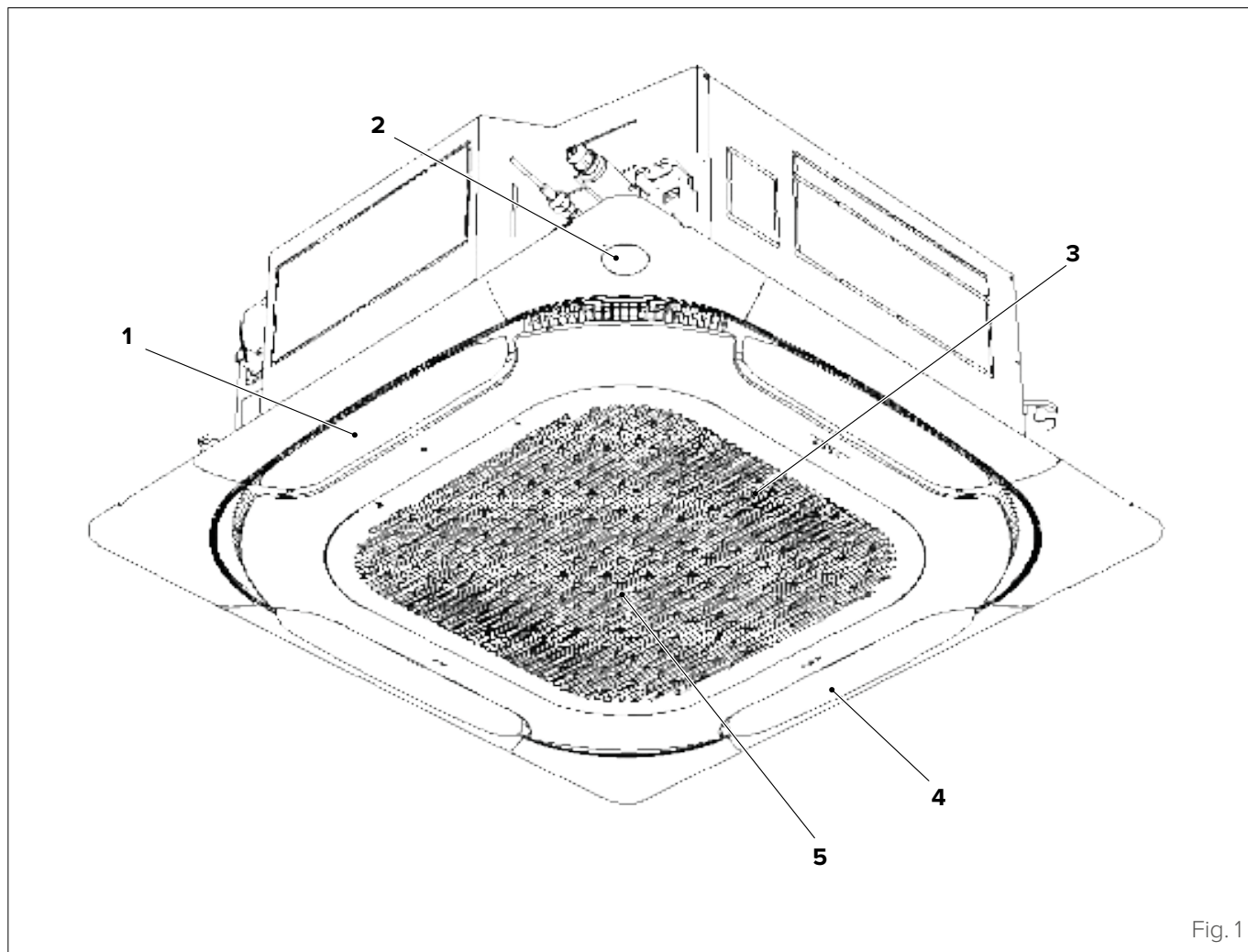

Fig. 1

- | | |
|-----------------------------|---------------------|
| 1 Ventilation louver | 4 Air outlet |
| 2 Display LED | 5 Air inlet |
| 3 Front grille | |











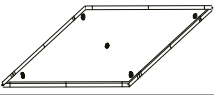

WARNING

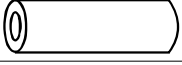
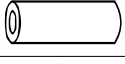

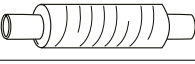

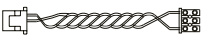
The images in this manual are provided for illustrative purposes only. The appearance of your appliance may differ slightly from the illustrations shown here. Refer to the actual characteristics of the unit.

1.3 Accessories

The air conditioning system is provided with the following accessories. Use all specified installation components and accessories to install it.

Description	Aspect	Quantity
Installation template		1
Foam (250x250x8)		1
Foam (60x100x5)		1
Cable tie		6
Insulation for copper piping		2
Insulation for water drain piping		1
Hose clamp		1
Cable tie for water drain piping		5
Flexible water drain hose		1
M6 bolt		4
Brass nut		2
D1D2 auxiliary connector		1
Installation manual		1

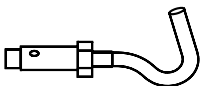
Accessories not supplied

Description	Aspect	Notes
Copper piping		Use to connect the internal refrigerant piping.
PVC water drain piping (outer Ø: 37-39 mm, inner Ø: 32 mm)		Use to drain condensate from the indoor unit.
Piping insulation		Protect the piping from condensate.
Hook with M10 expansion bolt		4 for indoor unit installation
M10 rods		4 for indoor unit installation

1.4 Identification

The indoor unit can be identified by the serial number label that shows the technical and performance data of the appliance and what is required by the legislation in force.

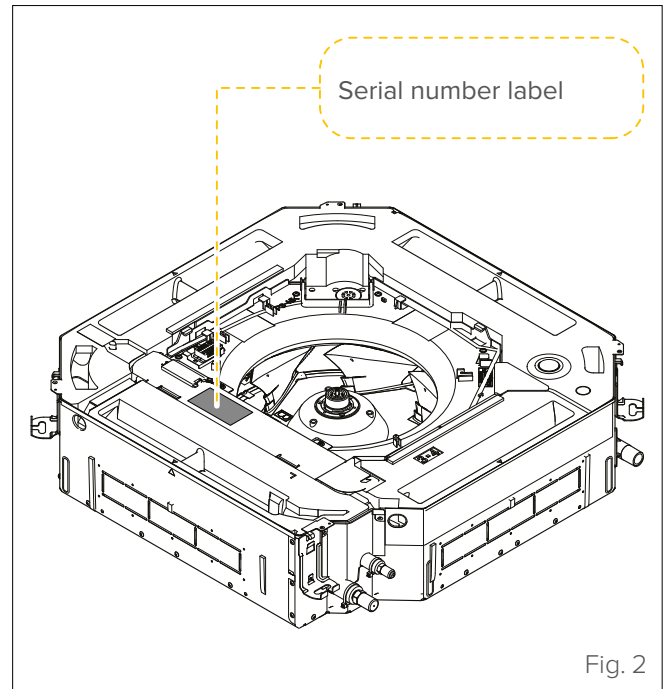

CAUTION

Tampering, removal, lack of identification labels or anything else that does not allow safe product identification, makes any installation and maintenance operation difficult.

2 INSTALLATION

2.1 Product receiving

The appliance is supplied packed in several parcels. Handling must be carried out by appropriate means in view of the overall weight of the package.

Upon receiving the appliance, check the perfect integrity of all parts.

In case of damage to the appliance or missing material, please contact your authorised dealer promptly.



WARNING

The manual is an integral part of the product and therefore it is recommended that you read it before installing and commissioning the appliance and keep it with care for future reference or transfer to another Owner or User.



IT IS PROHIBITED TO

disperse the packaging material in the environment and leave it within the reach of children as it can be a potential source of danger. It must be disposed of in accordance with current legislation.



WARNING

During all handling operations, use the appropriate PPE such as hard hat, gloves and safety shoes.

2.2 Size and weight

	Width (mm)	Depth (mm)	Height (mm)	Weight (kg)
D28	840	840	230	21.3
D36	840	840	230	21.3
D45	840	840	230	23.2
D56	840	840	230	23.2
D71	840	840	230	23.2
D80	840	840	230	23.2
D90	840	840	300	28.4
D100	840	840	300	28.4
D112	840	840	300	28.4
D140	840	840	300	30.7
Panel	950	950	70	5.8



CAUTION

Handle the appliance with the hooks. Do not exert any force on other parts of the unit, especially on refrigerant and water drain pipes and plastic parts.

2.3 Installation - preliminary warnings



WARNING

Before installing the indoor unit, consult the label on the product package to check that the model number matches the model number of the outdoor unit.



CAUTION

All installation operations must be carried out with the appliance completely stopped and after disconnecting all external power supplies. Before any installation work, pay close attention to the labels on the appliance. During the activities you must not tamper with or disconnect safety devices for any reason, create by-passes, or use them for purposes other than those envisaged by the manufacturer.

Below are the guidelines for achieving a compliant installation.

- Identify a suitable area for installation.**
See “Installation room” page 11.
- Put the appliance in place.**
See “Hang the indoor unit” page 14.
- Lay the refrigerant piping.**
- Perform correct installation of the condensate drain piping.**
- Clean the refrigerant piping.**
- Make the refrigerating connections.**
- Test the tightness of the system at the pressures indicated by the manufacturer.**
- Carry out the correct pressurisation of the system.**
- Carry out the electrical wiring, configurations and addressing according to the diagrams provided.**
See “Electrical connections” page 21.



ATTENTION ELECTRIC DANGER

- All electrical connections must be done by a licensed electrician according to the provisions of national and local electrical codes.
- All electrical connections must be made according to the wiring diagram on the panels of the indoor and outdoor units.
- If the electrical system has serious safety problems, stop work immediately. Explain the situation to the customer and refuse to install the unit until the safety problem has been resolved.
- The power supply should correspond to 90-100% of the rated voltage. Insufficient power supply may cause malfunction, electric shock or fire.
- If the power cables are permanently installed connected to the electrical system, install overcurrent protection and a main power switch with a capacity of 1.5 times the maximum current of the unit.
- The power supply line must have a special protection upstream against short circuits and earthing leakage that sections the system with respect to other utilities. The technician must choose an approved differential circuit-breaker or main circuit breaker.
- Connect the unit to a single socket of a dedicated branch of the circuit. Do not connect other appliances to the same electrical outlet.
- The air conditioner must be properly grounded.
- All cables and conductors must be connected securely. Loosening a conductor may cause the terminal to overheat, which in turn may result in fire hazards or product malfunction.
- The electrical cables must not touch or rest against the refrigerant pipes, the compressor or any moving parts of the unit.

2.4 Installation

2.4.1 Installation room



CAUTION

The appliance must be placed in a well-ventilated room, with a minimum surface area that varies according to the amount of refrigerant present.

The following information can help you choose a suitable location.

The installation location must have the following characteristics:

- good air circulation.
- ease of drainage.
- the noise emitted by the unit must not disturb other people.
- stability and robustness - no exposure to vibration.
- sufficient capacity to support the weight of the unit. If the structure is too weak, the unit can fall and cause serious or fatal personal injury, material damage and damage to the appliance.
- at least one metre away from any other electrical device (e.g. TV, radio, computer).
- installation at a height of 2.5m to 3.5m off the ground.
- if the indoor unit is installed on a metal bracket, it must be earthed.
- the unit must be at least 1m away from the nearest wall.
- the space must be sufficient for installation and maintenance operations.
- the space must be sufficient for connection of the piping and drain pipe.
- the ceiling must be horizontal and its structure must be strong enough to support the weight of the indoor unit.
- the air inlet and outlet must not be blocked.
- the airflow must be able to reach the whole room.



It is PROHIBITED to install the indoor unit in the following locations:

- in a bathroom or laundry room, because excess humidity can reduce its service life and corrode the cables;
- near sources of heat, steam or combustible gas;
- near flammable objects, such as curtains or fabrics;
- near obstacles that could obstruct air circulation;
- near the entrance;
- in an area that is not exposed to direct sunlight;
- areas exposed to strong electromagnetic waves;



It is PROHIBITED to install the indoor unit in the following locations:

- oil extraction drilling or fracking areas;
- coastal areas with extremely salty air;
- areas with an atmosphere impregnated with caustic gases, for example near thermal sources;
- areas subject to strong power fluctuations, for example factories;
- enclosed spaces (cabinets, etc.);
- kitchens with natural gas cooker hobs;
- areas used for storing gas or flammable materials.

Please refer to the following diagrams for installation distances:

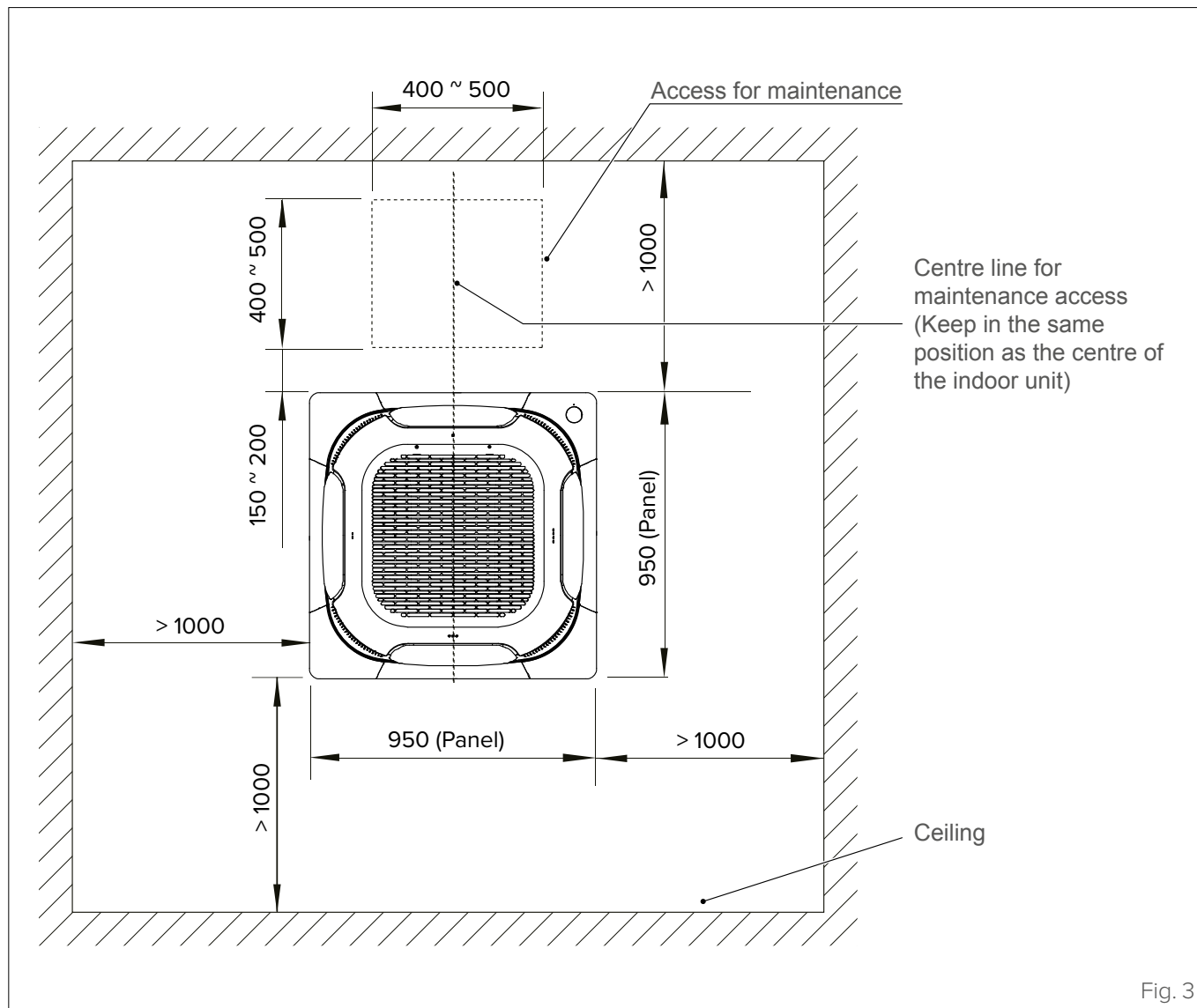

Fig. 3

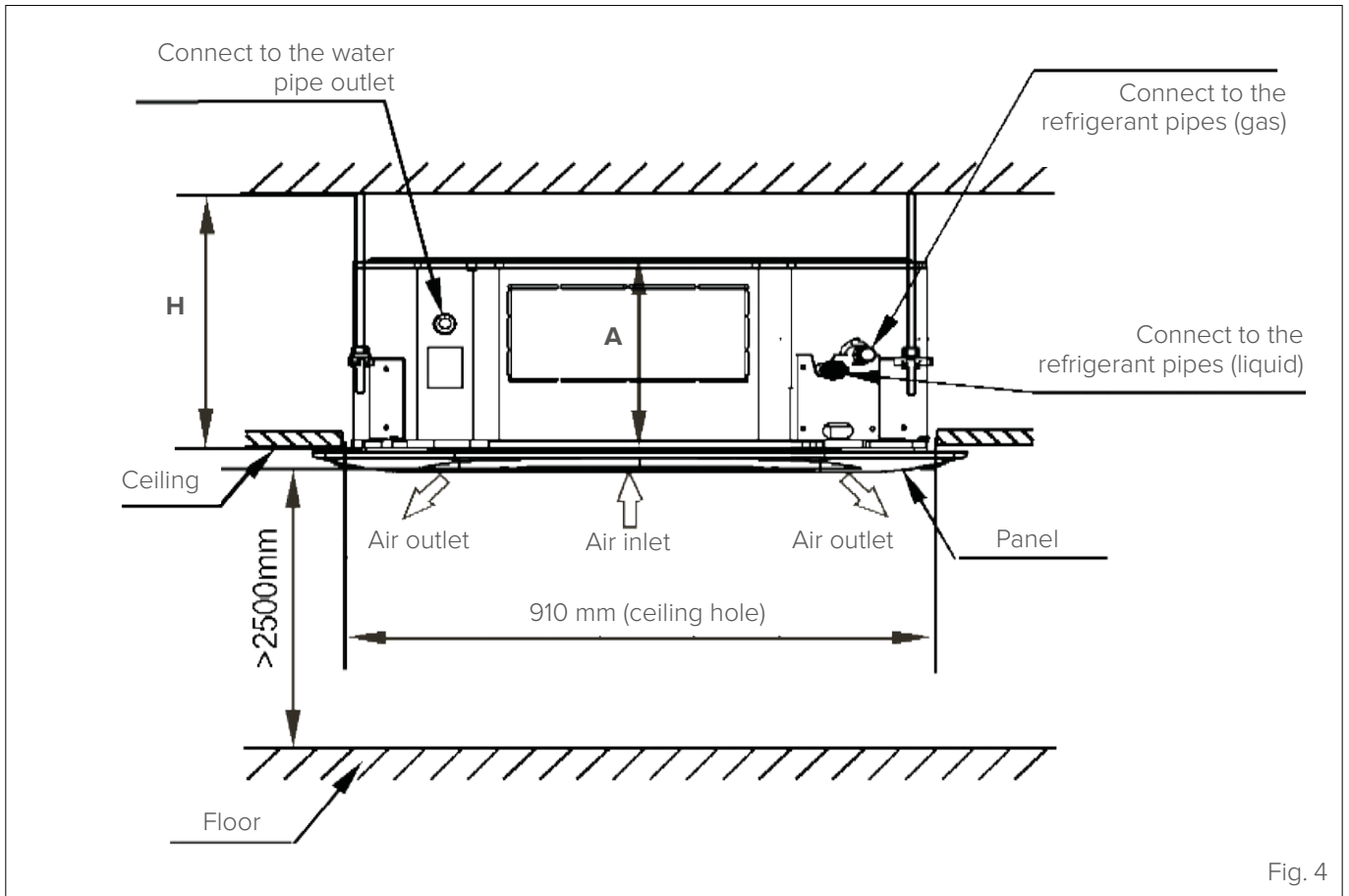

Fig. 4

Model	A (mm)	H (mm)
≤ 8.0 kW	230	≤ 260
≤ 9.0 kW	300	≤ 330

Based on the layout of the installation room, determine the direction of air flow. See “Fig. 5” for the air flow direction diagram. To lockout the air flow, a deflector must be inserted into the unit’s casing.

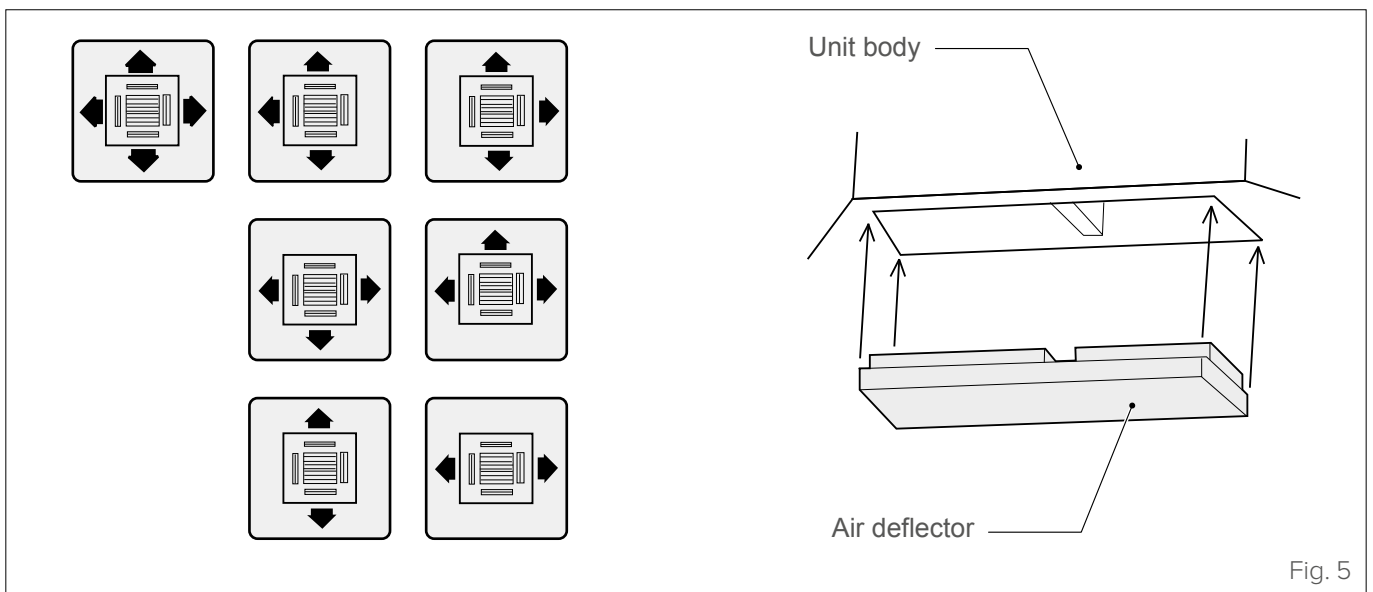

Fig. 5



WARNING

- The deflector is not included.
- Remove the panel before installing the deflector.

2.4.2 Hang the indoor unit

Size:

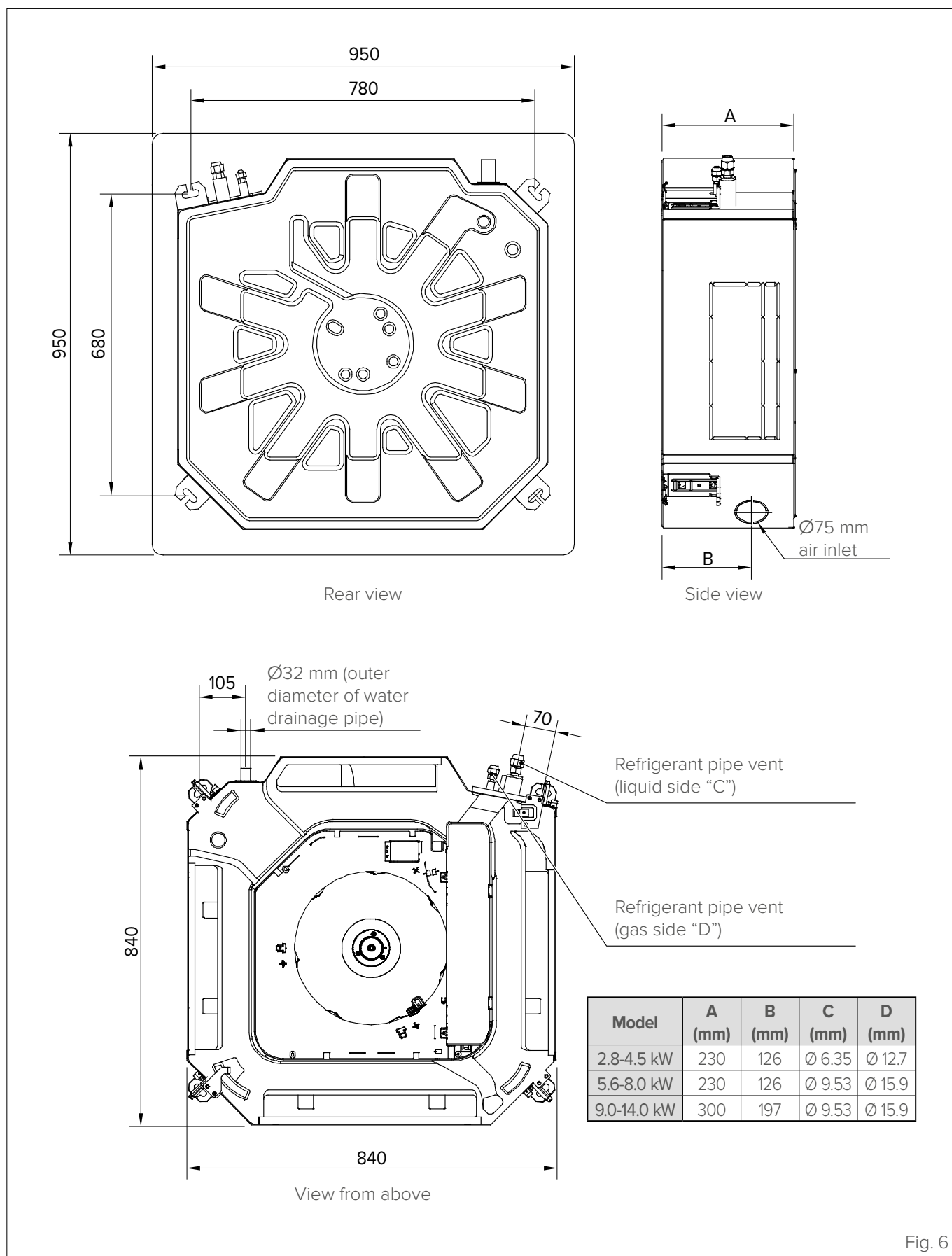

Fig. 6

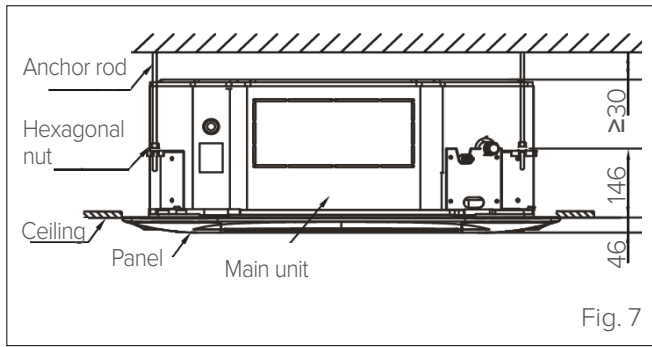

Fig. 7



CAUTION DANGER

Before installing the indoor unit, remove the packing elements (A) used for transport purposes between the fan and the pipe fitting. Do not start the unit without removing the elements (A) so as not to damage the fan motor.

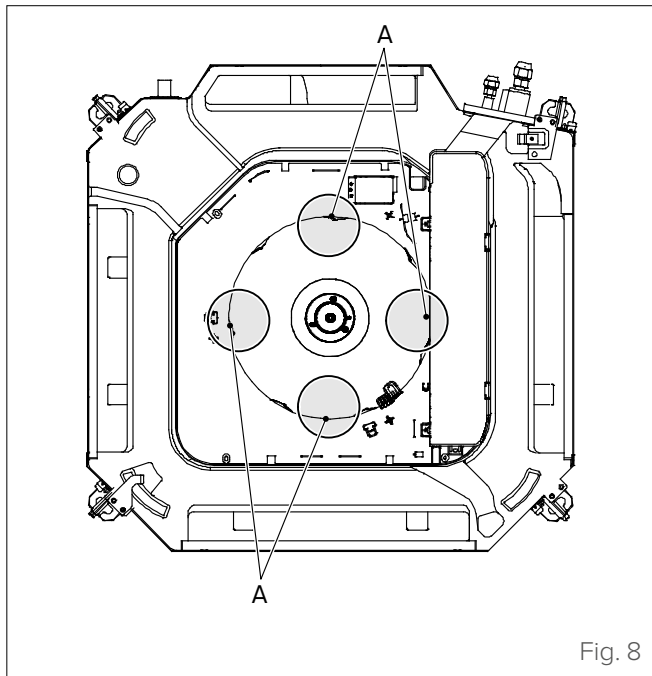

Fig. 8

- 1 Using the paper template provided, make a 910mm x 910mm hole in the ceiling.
- 2 The midpoint of the ceiling opening must correspond to the centre of the indoor unit's casing.

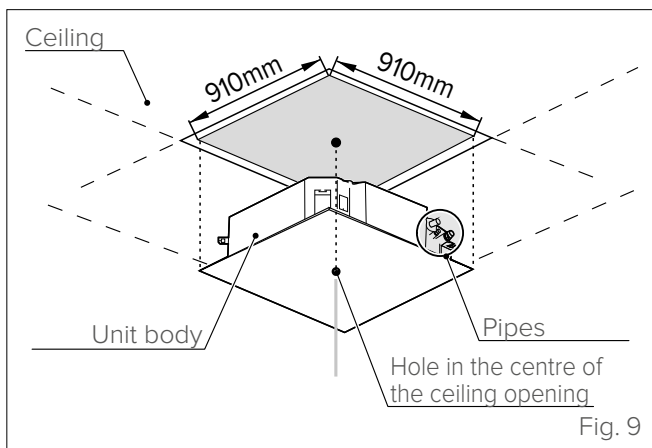

Fig. 9

- 3 Reinforce the ceiling where necessary to stop it from sagging.
- 4 Determine the length and direction of the pipes to be installed and the wiring.
- 5 After choosing the installation position, put the refrigerant piping, the drainage pipes and the internal and external electrical lines in their respective connection points before installing the appliance.
- 6 Locate and mark the position of the anchor rods in the 4 corners using the paper template provided.
- 7 Based on the type of ceiling and depending on the weight of the indoor unit, provide a suitable rod support system:

– **Roof with wooden structure**

Place the wooden assembly panel crosswise over the roof beam, then install the anchor rods

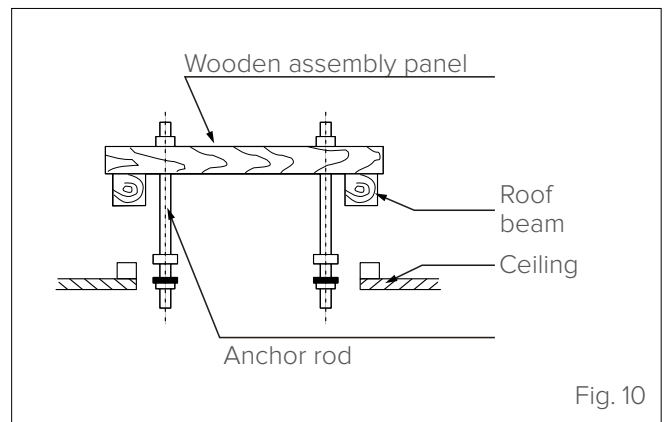

Fig. 10

– **New concrete slab**

Embed the anchor rods.

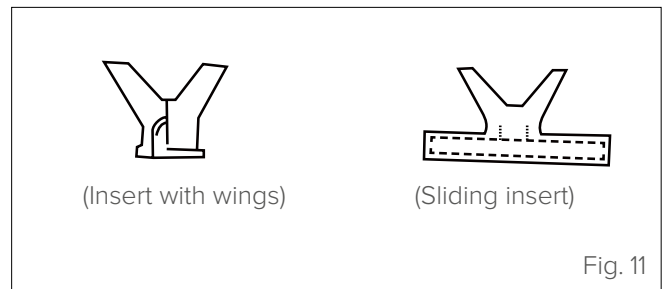

Fig. 11

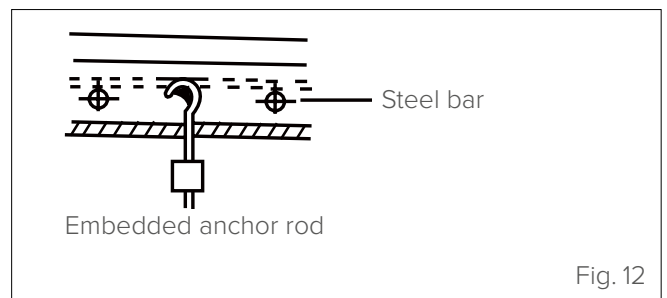

Fig. 12

– Existing concrete slab

Install the suspension hook with expansion anchor 45~50 mm deep in the concrete to prevent it from loosening.

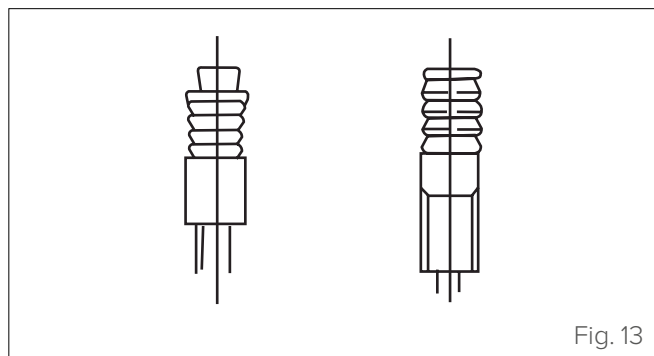

Fig. 13

– Roof with steel structure

Install and use the angled steel brackets

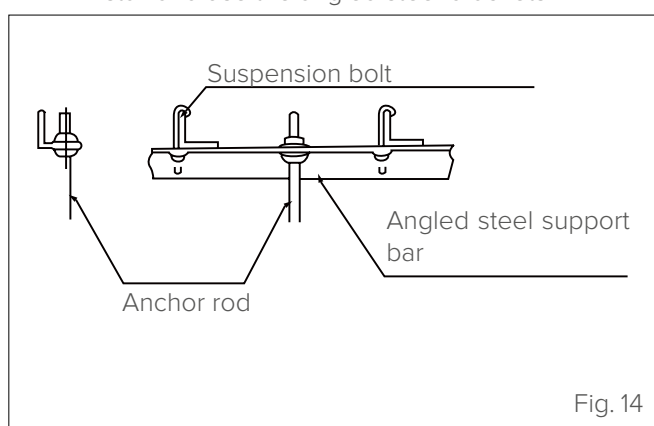

Fig. 14

8 Install the four anchor rods (M10).

9 Determine the length of the rods based on the height of the ceiling. Remove the surplus part.

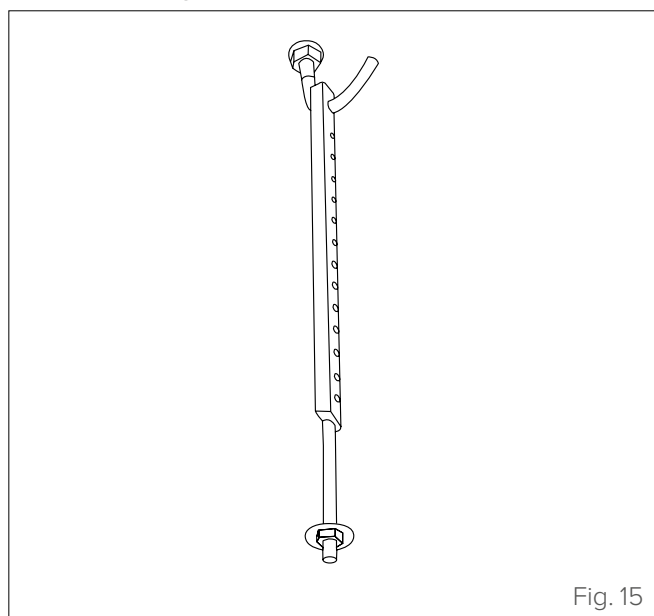

Fig. 15

10 Assemble the indoor unit. Two people are needed to lift and fasten the unit. Insert the anchor rods into the unit's attachment holes. Fasten them with washers and hexagonal nuts.

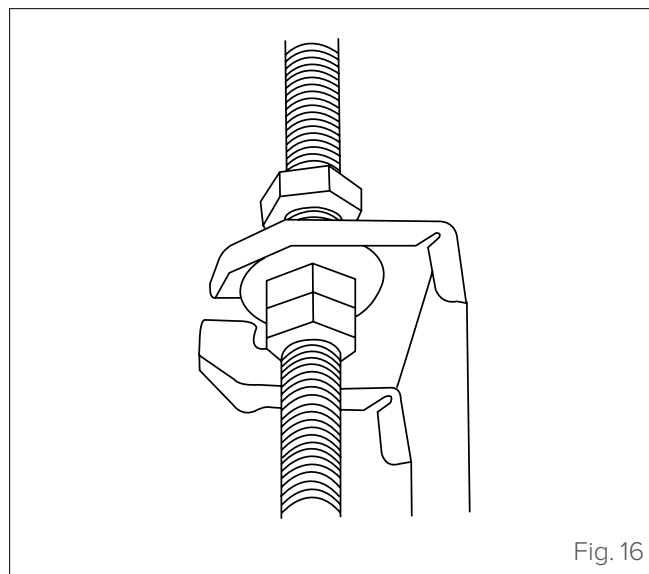

Fig. 16



WARNING

The bottom of the unit must be 10-12 mm higher than the false ceiling. In general, measurement "L" must be half the length of the anchor rod or be long enough to stop the nuts from coming off.

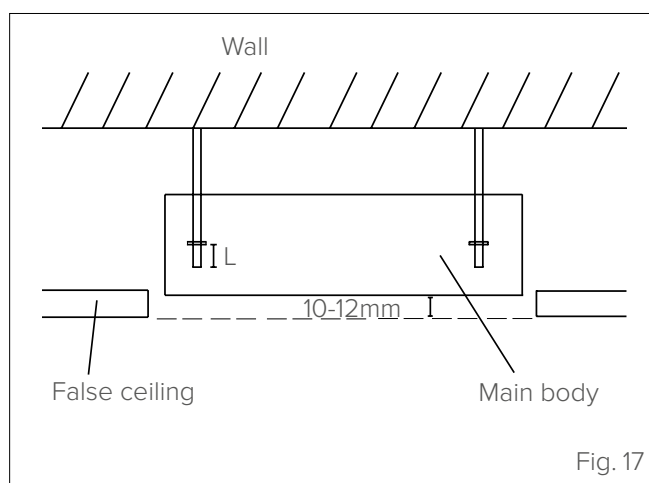

Fig. 17



CAUTION DANGER

Check that the unit is completely horizontal. Incorrect installation can cause the drain pipe to go back into the unit or possible water leaks.



CAUTION DANGER

The unit body must be aligned exactly with the hole. Before proceeding, check that the hole is the same size as the unit.

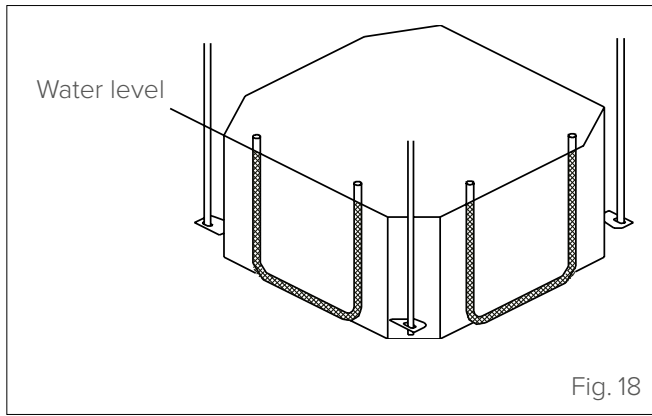

Fig. 18



WARNING

Check that the indoor unit is horizontal. The unit has a drain pump and a float switch. If the unit tilts in the opposite direction to that of the condensate flow (with the drain pipe side raised), the float switch may not work properly and cause a water leak.

- 11 Use the hexagonal nuts on the four assembly hooks to adjust and ensure that the unit's casing is level.
- 12 Adjust the position of the unit's casing and ensure that the gap with the ceiling is even on all four sides.
- 13 Once the position of the casing has been adjusted, tighten the nuts to secure the unit.

NOTE FOR INSTALLATION IN NEW BUILDS

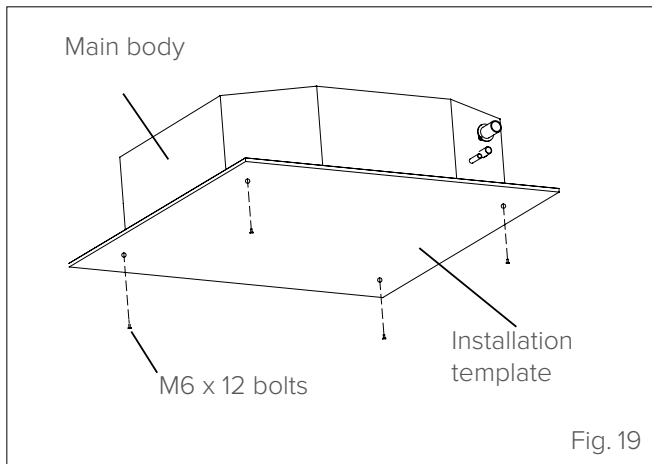

Fig. 19



WARNING

When the unit is to be installed in a new build, the hooks may already be fitted in the ceiling. In this case, check that the hooks have not come loose due to concrete shrinkage.

2.4.3 Derived ducts

These units can be fitted with small ducts for air conditioning a small room nearby. The units are designed for ducting on 3 sides: the side with the electronic expansion valve cannot be ducted.

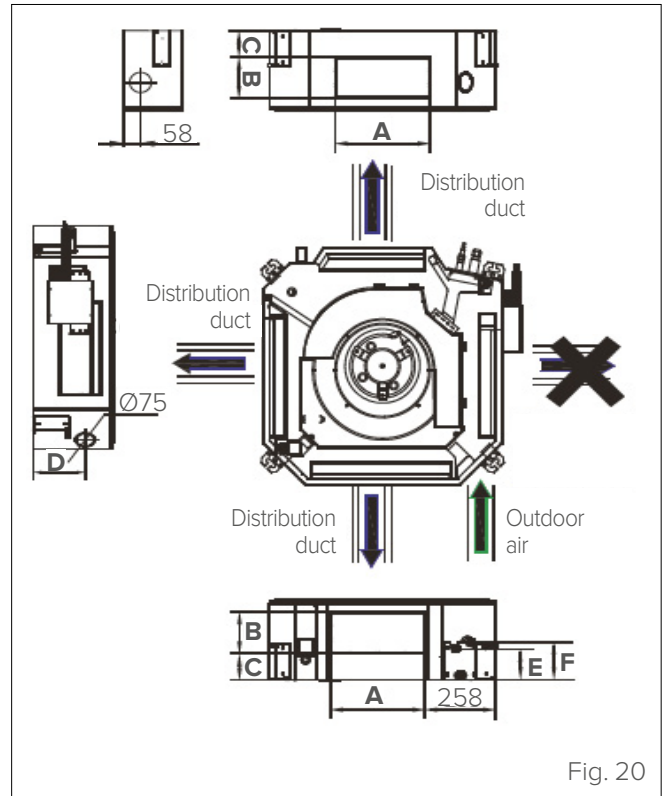

Fig. 20

Model	A (mm)	B (mm)	C (mm)	D (mm)	E (mm)	F (mm)
2.8-8.0 kW	350	85	107	126	121	145
9.0-14.0 kW	350	155	107	197	121	145

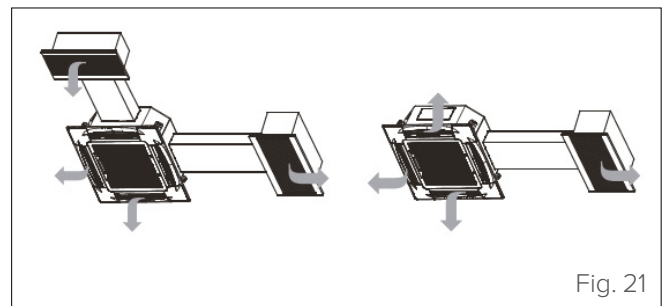

Fig. 21

- If only one air duct is connected:
 - for 5.6~8.0 kW models, the volume of air in the duct is about 300~360 m³/h.
 - for 9.0~14.0 kW models, the volume of air in the duct is about 400~640 m³/h.
- The air duct must not be longer than 2 metres.

- If two air ducts are connected:
for 5.6~8.0 kW models, the volume of air in the duct is about 200~260 m³/h.

for 9.0~14.0 kW models, the volume of air in the duct is about 300~500 m³/h.

The air duct must not be longer than 1.5 metres.



WARNING

If a duct is connected, the corresponding louver on the panel must be plugged.
If the capacity of the unit is less than 5.6 kW, no air duct can be connected.

2.4.4 Preparation for connection pipes

It is necessary to make a hole in the wall where the refrigerant piping, drainage pipe and electrical cables that will connect the indoor unit to the outdoor unit will pass through.

- 1 Determine hole position in the wall according to the position of the outdoor unit.
- 2 Drill the hole in the wall using a 65 mm drill bit. The hole should have a slight inclination, so that the outer end is lower than the inner one by about 12 mm. This will facilitate water drainage.

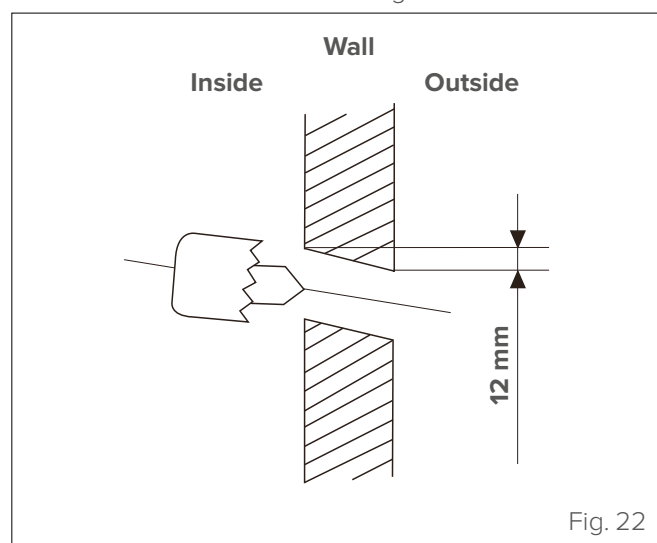

Fig. 22

- 3 Insert the protective sleeve into the wall, which will protect the edges of the hole and improve the seal after installation.



CAUTION DANGER

When drilling holes, pay attention to avoid electrical wires, hydraulic hoses and other delicate components.



CAUTION

The drain pipe outlet must be at least 5 cm from the floor. If it touches the ground, the unit can block and not work properly. If the water is discharged directly into the sewer system, use a U- or S-shaped drain pipe to block odours which would otherwise flow back inside.

2.4.5 Drainage pipe

The drainage pipe is used to drain the water from the unit. Incorrect installation can cause damage to the unit and other material damage.



CAUTION DANGER

- Insulate all of the pipes to prevent condensate from forming, which could cause water damage.
- If the drainage pipe is bent or not installed properly, the water can escape and cause the float switch to malfunction.
- In HEAT mode, the unit discharges water. Make sure that the drainage pipe is in a suitable area to avoid water damage and slipping hazards caused by the discharge water freezing.
- **DO NOT** pull the drainage pipe, as this could detach it.



WARNING

This installation requires a polyethylene pipe (outer diameter = 37-39 mm, inner diameter = 32 mm). Depending on actual installation requirements, users can buy suitably sized pipes from their local dealer, from an after-sales service centre or directly off the market.

- 1 Insert the water drain pipe into the unit's water intake connection pipe and use a clamping ring to securely close the insulated water drain pipes.
- 2 Use the water drain pipe insulation to tie the indoor unit's water intake and drain pipes together (particularly for the indoor part) and use water drain pipe cable ties to tie them securely and ensure that the air does not enter and condense.
- 3 In order to prevent water from flowing back into the air conditioner after the operation has been completed, the water drain pipe should be inclined outwards with a slope (drainage part) greater than 1/100. Ensure that the water drain pipe does not bulge or retain water. If it does, then it will be noisy. See "Fig. 23".
- 4 When connecting the water drain pipe, do not pull the intake pipes with force so that the connections do not come loose. At the same time, fit a support bracket

Installation

every 0.8~1 metres to prevent the water drain pipes from bending. See “Fig. 23”.

- 5 When connecting a long water drain pipe, the connections must be covered with insulation to prevent them from coming loose.
- 6 When the water drain pipe outlet is higher than the water intake pipe connection, try to keep the drain pipe as vertical as possible; the outlet pipe connections will bend so that the height of the drain pipe is 1000 mm from the base of the drain pan. Vice versa, there will be an excessive flow of water at the end of operation. See “Fig. 24”.

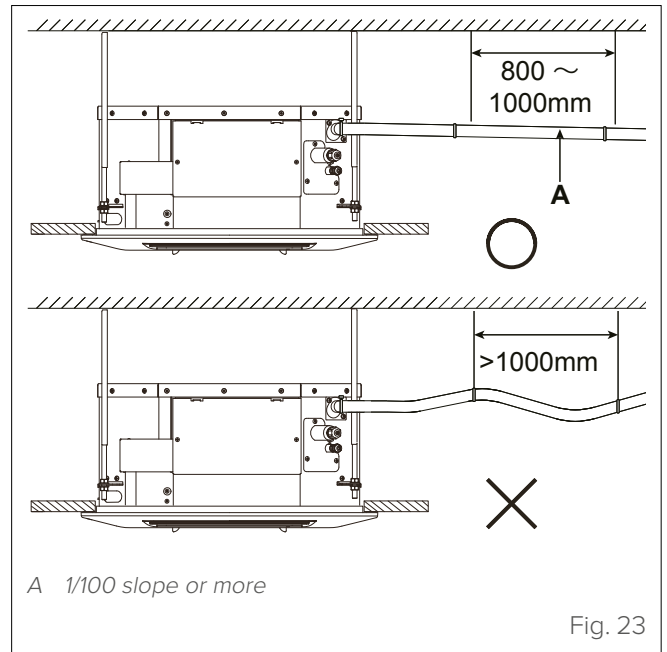

Water drain pipes from multiple units are connected to the main drain pipe that flows into the waste water pipes.

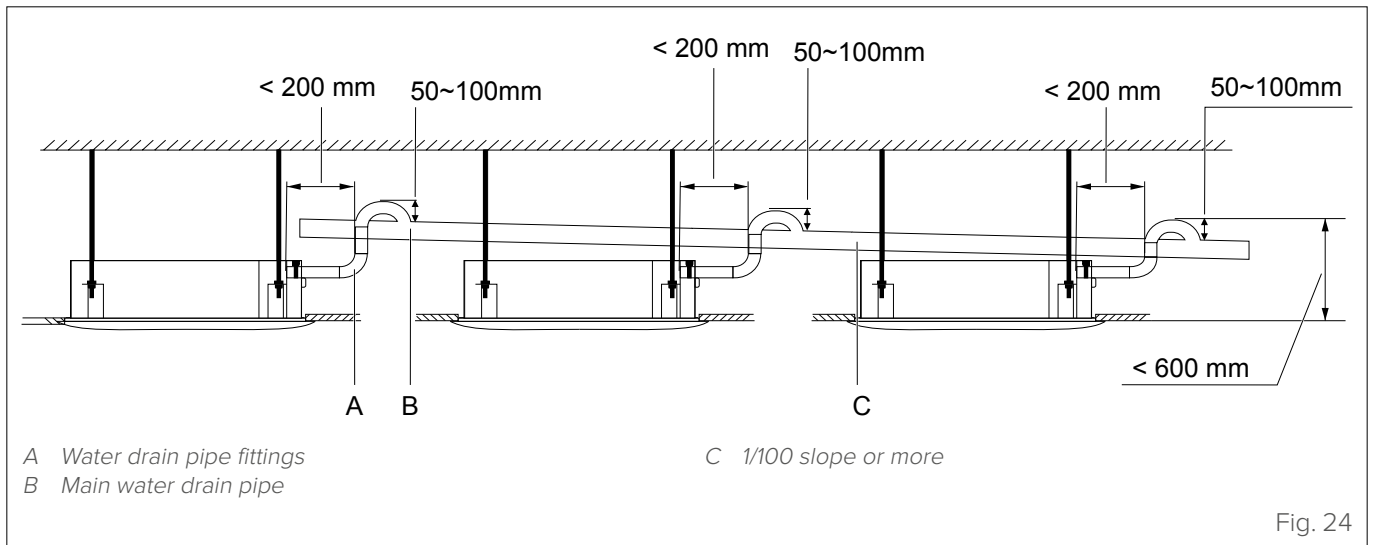

- 7 The end of the drain pipe must be more than 50 mm off the ground or base of the drain slot. Moreover, do not put the pipe in the water.

**WARNING**

- When using an extension for the drainage pipe, tighten the connection on the inside with an additional protection pipe to stop it from coming loose.
- The drainage pipe must slope by at least 1/100 to prevent the water from flowing back into the air conditioner.
- To stop the pipe from bending, fix the suspension elements every 1-1.5 m.
- If the drainage pipe outlet is higher than the pump fitting on the unit body, use a lifting pipe for the discharge outlet of the indoor unit. The lifting pipe must be installed no more than 100 cm from the false ceiling and no further than 20 cm from the unit. Incorrect installation can cause the water to flow back into the unit.
- To prevent air bubbles from forming, keep the drainage pipe horizontal or slightly inclined upwards (<75 mm).

**CAUTION DANGER**

- The drain cap at the base of the unit's casing is used to drain the water accumulated in the drain pan should the air conditioner malfunction. When the air conditioner is operating normally, make sure that the drain cap is closed properly to prevent water from leaking.

CHECK DRAINAGE

Before the test, ensure that the water drain flows smoothly and check that each connection is properly sealed.

Run the water drain test in the new room before completing the ceiling.

- 1 Connect the power supply and set the air conditioner to operate in cooling mode. Check the sound of the drainage pump in operation, and whether the water adequately drains from the discharge water outlet.

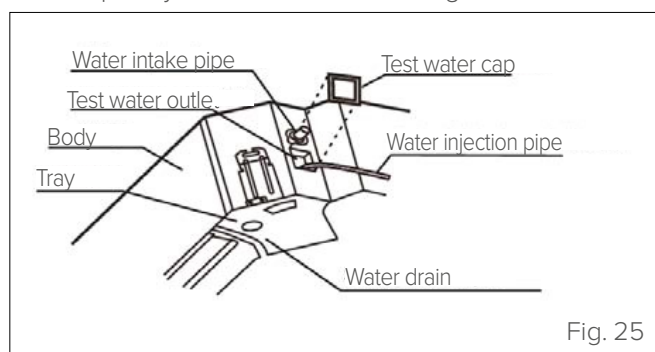

Fig. 25

- 2 Switch off the air conditioner and after 3 minutes check for any abnormal situations. If the drainage pipe remains exposed for any reason, too much water may flow back and cause a warning light on the electrical panel to flash or the water tank to overflow
- 3 Continue to add water until the water level exceeds the alarm level for 3 minutes, the appliance goes into alarm and switches off. A protection function prevents the air conditioner from being operated for about 3 minutes when it is restarted immediately after being switched off
- 4 Switch it off, remove the water and put the water control cover back in place.

3 ELECTRICAL CONNECTIONS

3.1 Preliminary information



ATTENTION ELECTRIC DANGER

- All electrical connections must be done by a licensed electrician according to the provisions of national and local electrical codes.
- Only use copper cables.
- Air conditioners must use a dedicated power supply socket. The power supply voltage must be in line with the rated voltage.
- Electrical wiring must be carried out by a qualified technician and must comply with the circuit diagram labels.
- Before carrying out electrical connections, close the power supply to prevent electric shocks from causing injury.
- The air conditioner’s outdoor power supply must include an earth line, and the earth line of the power cable to the indoor unit must be safely connected to the earth line to the outdoor power supply.
- Differential circuit-breakers must be configured in compliance with the current technical standards and requirements for electrical and electronic devices.
- The connected fixed wiring must be equipped with a differential circuit-breaker with a contact separation distance of at least 3 mm.
- The power cable must be at least 300 mm away from the signalling line in order to prevent electrical interference, malfunctions or damage to electrical components. Similarly, these lines must not come into contact with pipes or valves.
- The electrical wiring must comply with the relevant electrical requirements.
- After completing the wiring and connections and ensuring that they are correct, connect the power supply.



ATTENTION ELECTRIC DANGER

Before making electrical connections, turn off the main switch of the system.

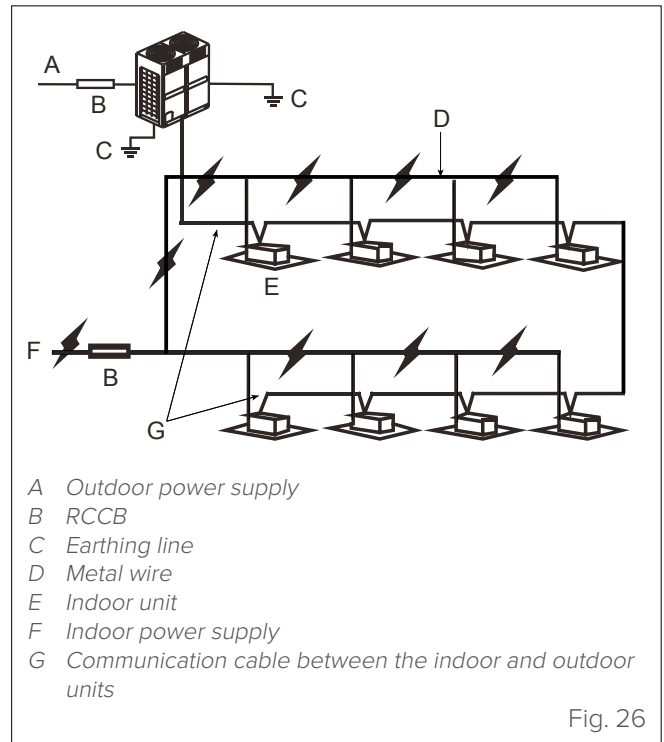

Fig. 26

The specifications for the power cable and communication cable are given below. Wiring with not enough power can cause the electrical wiring to overheat and result in an accident if the unit is damaged.

Model		2.2 - 7.1 kW
Power supply	Phase	1-phase
	Volts and frequency	220-240V~50Hz 220-240V~50/60Hz
Communication cable between the indoor and outdoor units		Shielded 3×AWG16-AWG18
Communication cable between the indoor unit and the wired controller		Shielded AWG16-AWG20
Fuses		15A

3.2 Power cable connection

Use a dedicated power supply to the indoor unit that is different from that to the outdoor unit.
Indoor units connected to the same outdoor unit must be connected to the same power supply, the same circuit breaker and the same differential circuit-breaker.

“Fig. 27” shows the power supply terminal of the indoor unit.

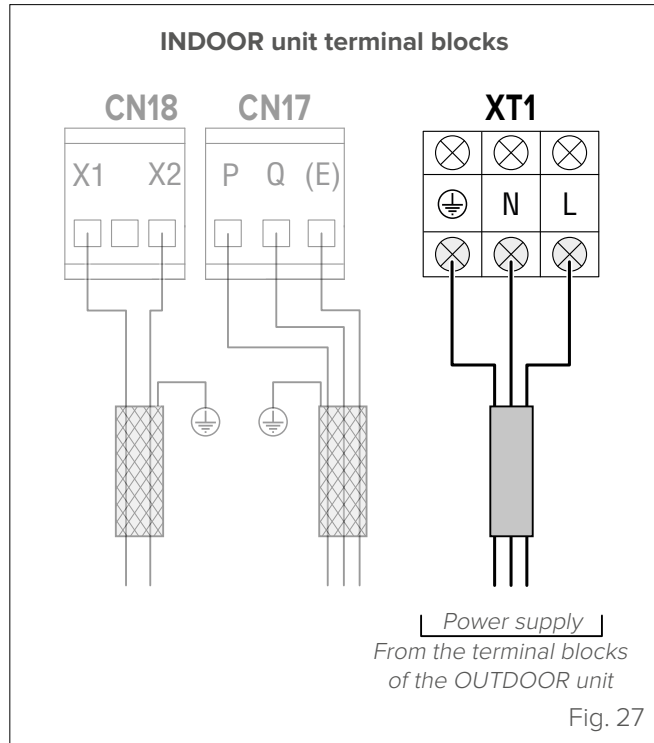

Fig. 27

To connect to the power supply terminal, use the insulated ring terminal “Fig. 28”.
Use a power cable that meets the specifications and securely connect it. To prevent the cable from being pulled from the outside, make sure it is securely fastened.

If the insulated ring terminal cannot be used, make sure you:

- Do not connect two power cables with different diameters to the same terminal (this can cause the cables to overheat due to loose wiring) “Fig. 28”.

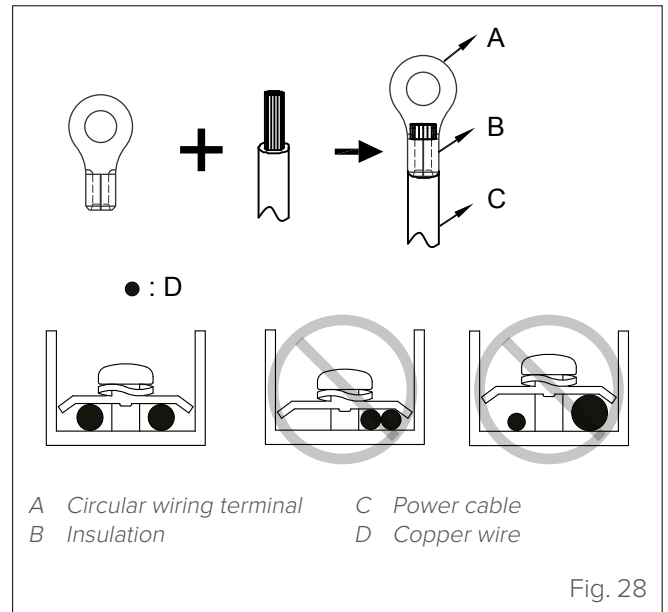

Fig. 28

3.2.1 Electrical wiring specifications

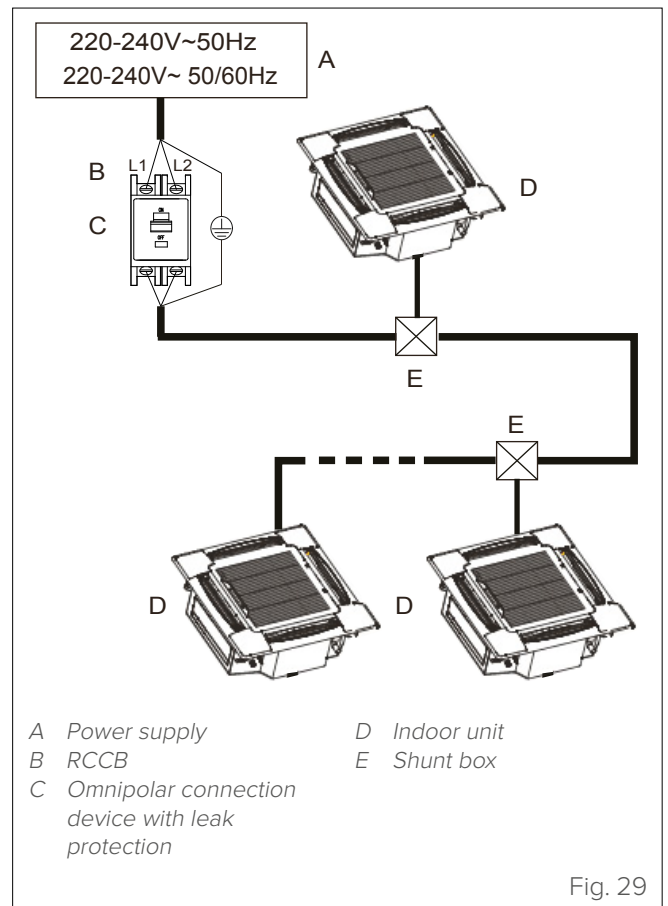

Fig. 29

Refer to the tables below for power cable specifications.

Electrical characteristics of indoor units

Capacity	Power supply			IFM		
	Hz	Volts	MCA	MFA	kW	FLA
2.8 kW	50 50/60	220- 240	0.41	15	0.08	0.33
3.6 kW			0.41	15	0.08	0.33
4.5 kW			0.56	15	0.08	0.45
5.6 kW			0.56	15	0.08	0.45
7.1 kW			0.56	15	0.08	0.45
8.0 kW			0.76	15	0.08	0.61
9.0 kW			0.88	15	0.17	0.70
10.0 kW			1.00	15	0.17	0.80
11.2 kW			1.00	15	0.17	0.80
14.0 kW			1.20	15	0.17	0.96

Abbreviations:

MCA: Minimum circuit Amps

MFA: Maximum fuse Amps

IFM: Indoor unit fan motor

kW: Motor rated power

FLA: Full load Amps

- 1 Select the individual cable diameters (minimum value) for each unit based on the table below:

Rated current of the appliance (A)	Nominal section area (mm ²)	
	Flexible cables	Fixed wiring cable
≤ 3	0.5 < ... ≥ 0.75	1 < ... ≥ 2.5
3 < ... ≥ 6	0.75 < ... ≥ 1	1 < ... ≥ 2.5
6 < ... ≥ 10	1 < ... ≥ 1.5	1 < ... ≥ 2.5
10 < ... ≥ 16	1.5 < ... ≥ 2.5	1.5 < ... ≥ 4
16 < ... ≥ 25	2.5 < ... ≥ 4	2.5 < ... ≥ 6
25 < ... ≥ 32	4 < ... ≥ 6	4 < ... ≥ 10
32 < ... ≥ 50	6 < ... ≥ 10	6 < ... ≥ 16
50 < ... ≥ 63	10 < ... ≥ 16	10 < ... ≥ 25

- 2 The maximum permissible variation of the voltage range between phases is 2%.



WARNING

Choose the power cable and wiring with reference to the laws and regulations in force. Assign a professional to choose and install the wiring.

3.3 Communication wiring

- Only use shielded cables for communication wiring. Any other type of cable can produce interference between signals, causing the units to malfunction.
- Do not carry out electrical work such as welding with the equipment switched on.
- All shielded wiring in the network is interconnected, and possibly earthed at the same point.
- Do not tie refrigerant pipes, power cables and communication cables together. If the power cable and communication wiring are parallel, the distance between the two lines must be 300 mm or more to prevent signal source interference.
- The communication wiring must not form a closed circuit.

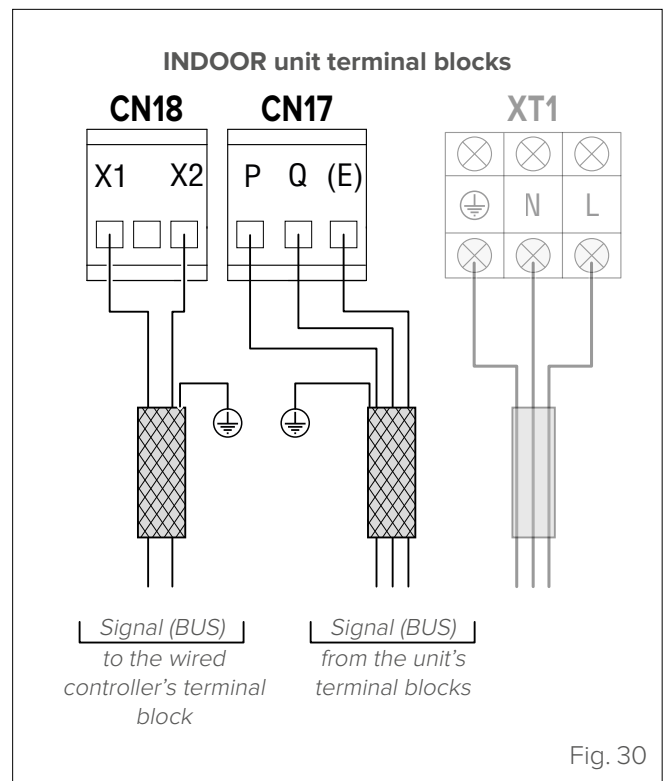

Fig. 30

3.3.1 Communication wiring between the indoor and outdoor units

- The indoor and outdoor units communicate via the RS485 serial port.
- Wire the communication bus of the indoor and outdoor units in a daisy-chain configuration from the master outdoor unit to the last indoor unit. The shielding must be connected properly to earth at one point.
- To increase the stability of the communication system, add a resistor to the last indoor unit. See “Fig. 31”.
- Do not use star or closed-loop connections because they are incorrect: they cause instability in the communication system and faults in the control system.
- Use a three-pole shielded cable (0.75 mm² or more) for the communication wiring between the indoor and outdoor units. Ensure that the wiring is connected properly. The connection for this communication cable must come from the main outdoor unit.
- Install a 120 Ohm termination heater between terminals P-Q of the last indoor unit.

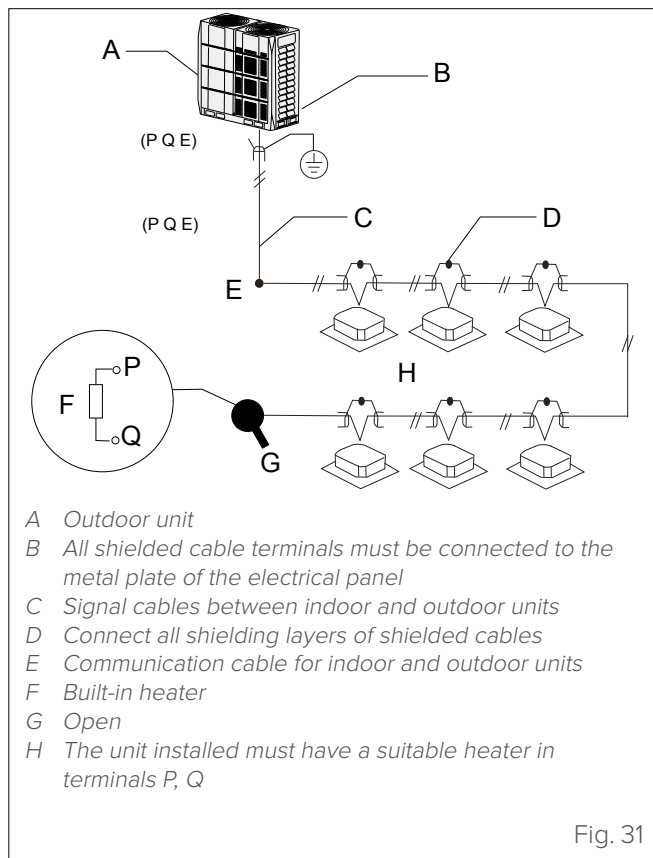

Fig. 31

3.3.2 Communication wiring between the indoor unit and the wired controller

The wired controller and the indoor unit can be connected in different ways, depending on the forms of communication.

1 For a two-way communication mode:

- Use 1 wired controller or 2 wired controllers (one main and one secondary) to control 1 indoor unit (See “Fig. 31”);

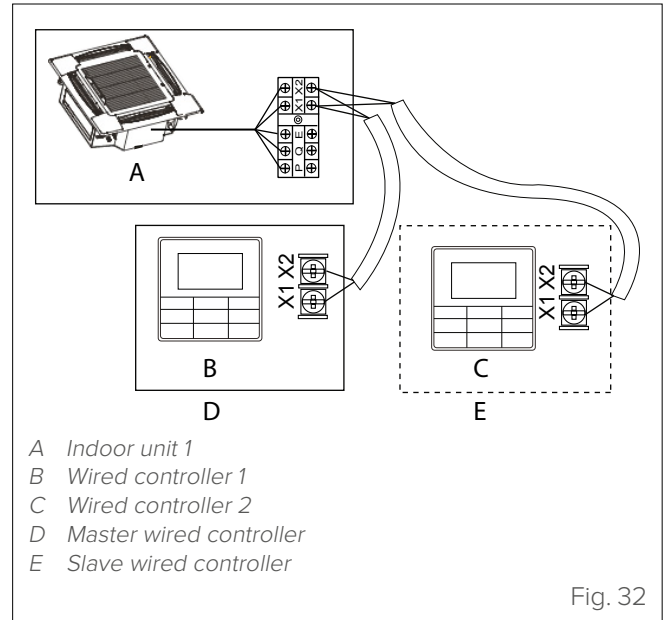

Fig. 32

- Use 1 wired controller or 2 wired controllers (one main and one secondary) to control multiple indoor units (See “Fig. 33”);

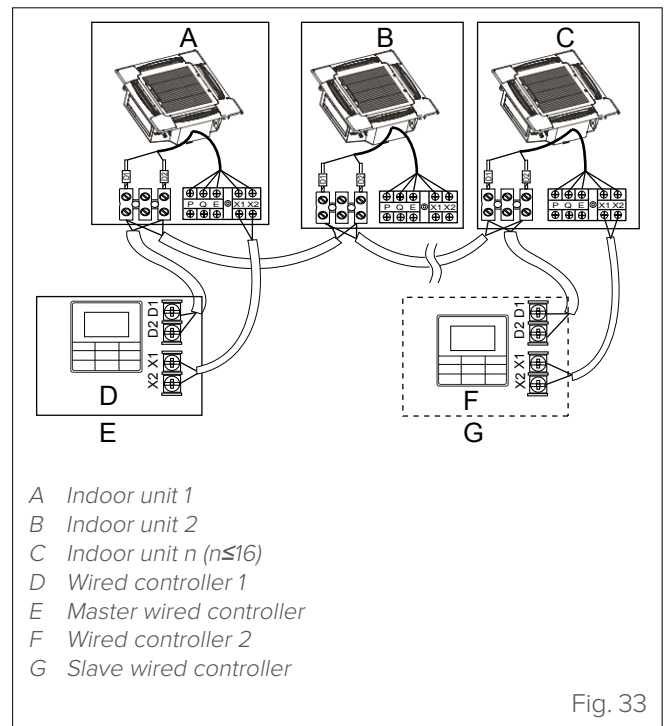
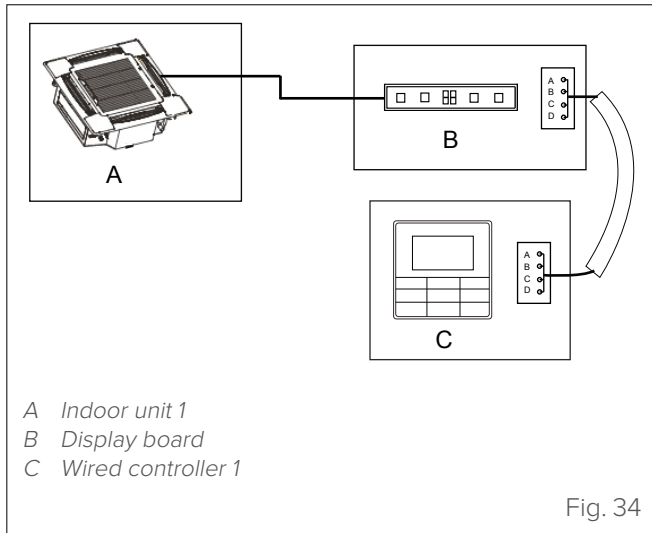

Fig. 33

2 For a one-way communication mode

- Use 1 wired controller to control 1 indoor unit (See “Fig. 34”).



- Once the wiring has been laid and the connections have been made, fasten and secure the wiring properly to prevent an external force from pulling on the connection point.
- Keep the wiring straight so that there are no differences in height that prevent the electrical panel cover from being closed tightly.
- Use professional insulating and sealing materials to seal and protect perforated cables. Inadequate sealing can lead to condensation and encourage the entry of small animals or insects which can cause short circuits in parts of the electrical system, thereby causing a fault.

- For connection, refer to the wiring and connection instructions in the wired controller manual.
- Ports X1/X2, D1/D2 on either side of the main control board and the one-way communication port (display board side) are for different types of wired controller (See “Fig. 35”).
- Use the connection cables (accessory) to connect ports D1/D2.

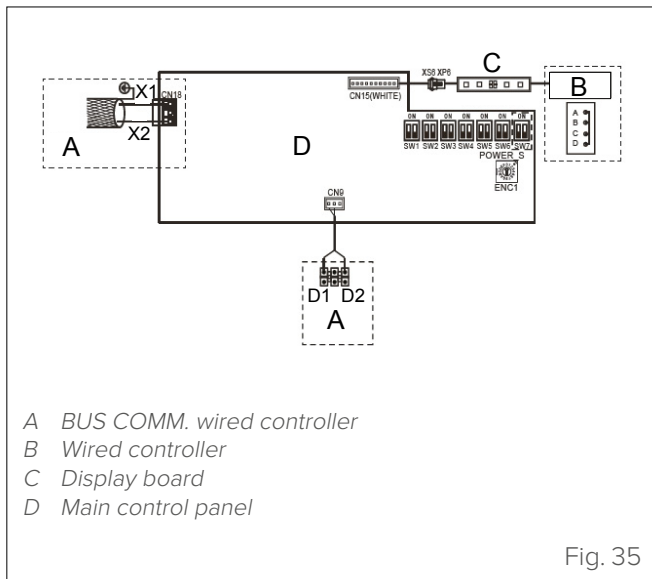

3.4 Assembling the panel



IT IS PROHIBITED TO

- place the panel face down on the floor, against a wall or on an uneven surface.
- hit or crush the deflector.

1 Remove the air intake grille.

- Push the two tongues towards the centre at the same time to unlock the grille catch

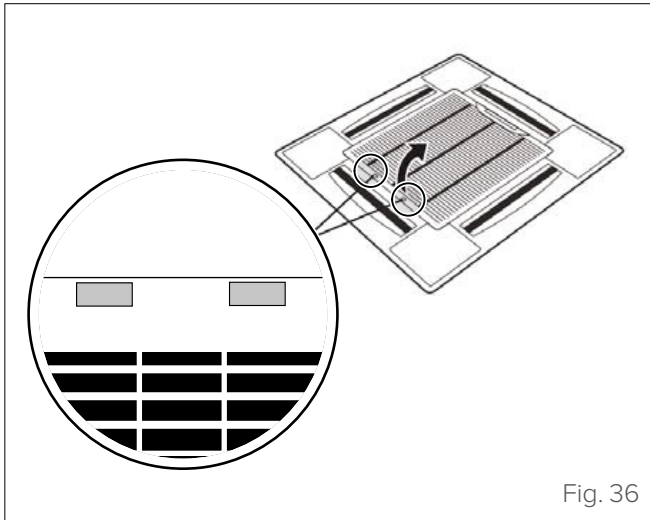

- Lift the air intake grille about 45° and detach it from the main body.

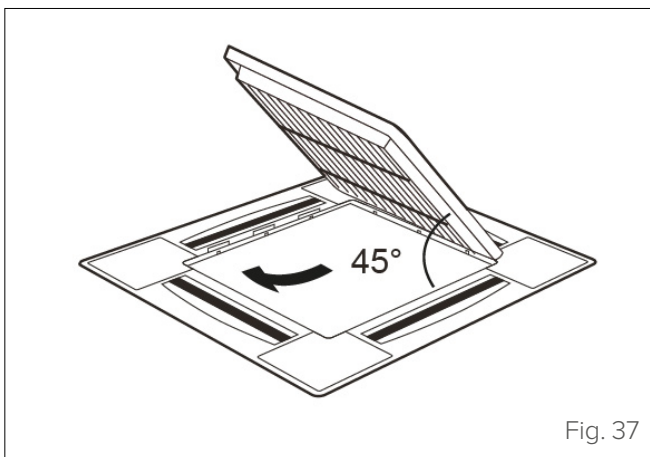

WARNING

One panel air vent is shorter than the other three. During installation, position the panel so that the shortest vent is in line with the shortest louver on the unit body.

2 Remove the installation covers in the four corners by sliding them outwards.

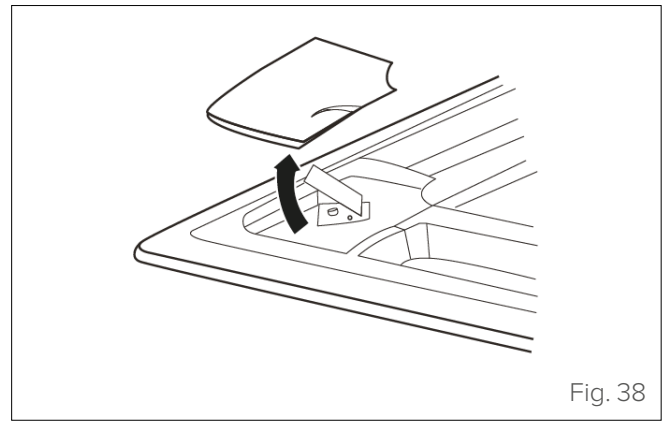

3 Install the panel

- Align the panel with the main unit body, taking into account the position of the pipes and the drain side.
- Attach the four panel rings to the indoor unit hooks.
- First hang the swing motor side of the panel and hook the drain pan hook onto the opposite side. Then hang the two remaining hooks on the corresponding suspension bracket of the indoor unit casing.

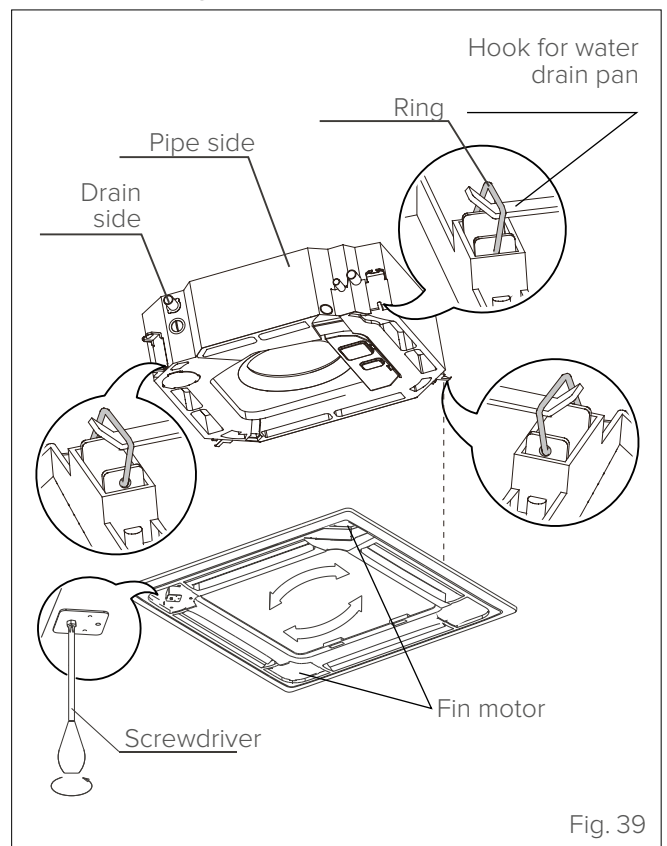

- Electrically connect the motor and display: insert the swing motor cable into the housing on the panel and connect the connection cables from the swing motor and the display box from the panel to the corresponding connectors on the unit casing. Use a protective sleeve to wrap the connection terminals. Use a reliable fastener and reinforce the safety insulation of the terminals.

Electrical connections

- Position and secure the panel on the main unit body with M6 bolts and washers. Ensure that the motors are embedded in the housing provided.
- Tighten the screws of the panel hooks in the four corners equally.



CAUTION

Tighten the screws until the thickness of the spongy material between the main body and the panel is down to 4-6 mm. The edge of the panel must fully touch the ceiling.

- Adjust the panel by turning it to completely cover the opening in the ceiling.

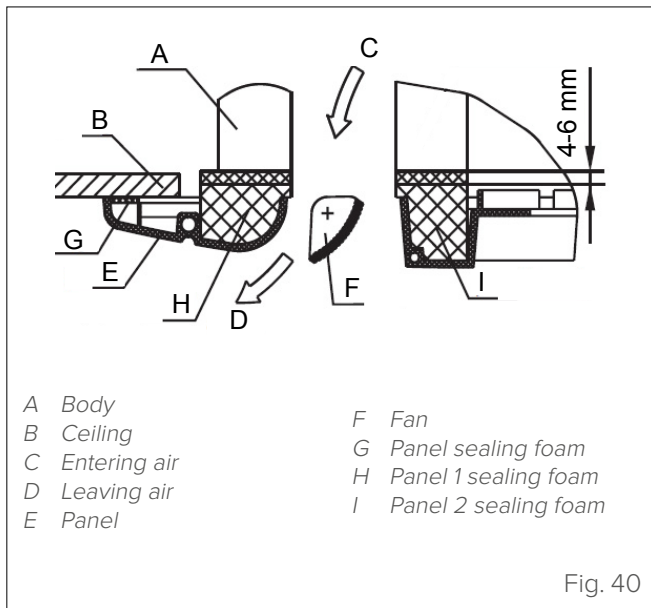

- Ensure that the wiring is free and the cables are not squashed.
- Fasten the screws properly to prevent air or water leaks.



CAUTION

Insufficient tightening of the screws can cause water leaks.

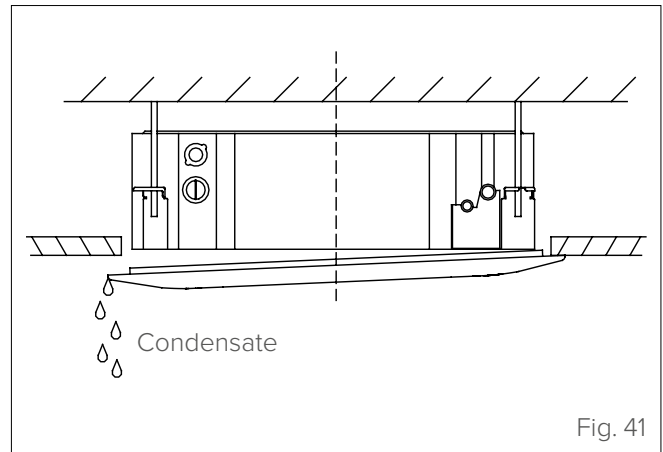

CAUTION

If the unit is not hung properly and there is an empty space, the height of the unit will have to be adjusted to ensure correct operation.



WARNING

The height of the unit can be adjusted through the openings on the four sides of the panel by unscrewing the top nut and adjusting the bottom nut. Check that this adjustment does not affect the internal electrical connections and the drain pipe.

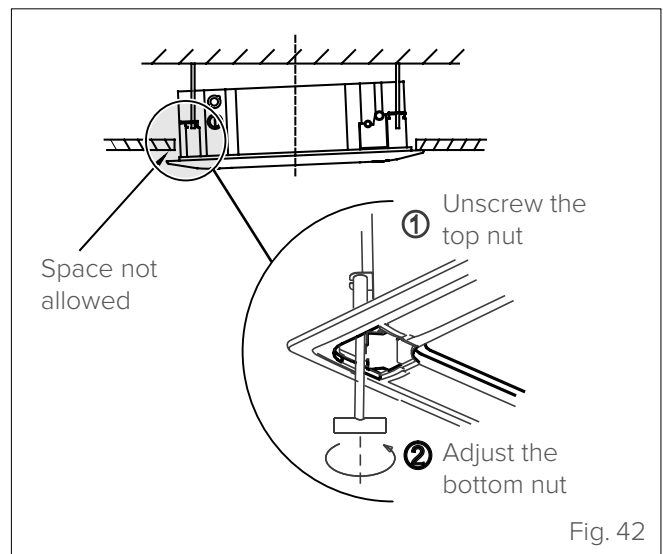

- Insert a protective sheath and connect the panel connectors to the corresponding connectors on the main body.
- Slide the sheath over the connectors and tie it with cable ties to securely fasten both ends.

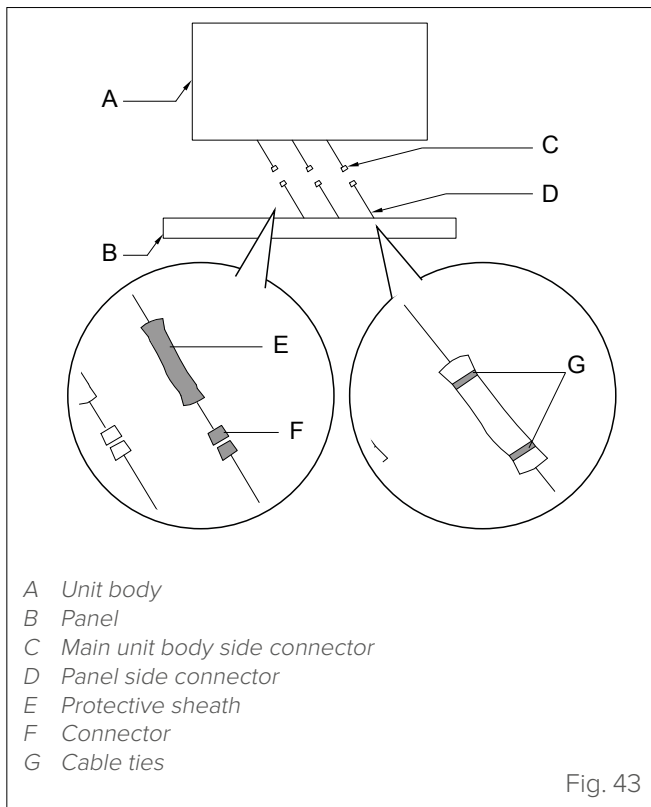

- Fasten the installation covers to the four corners by pushing them inwards.

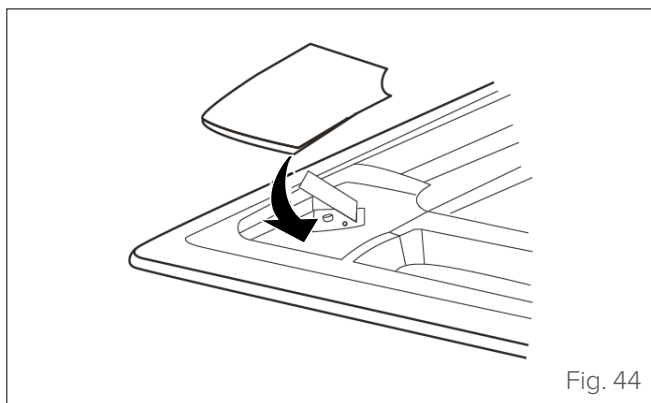

- Refit the air intake grille, following the steps used to remove it in reverse order.

- Fasten the door.

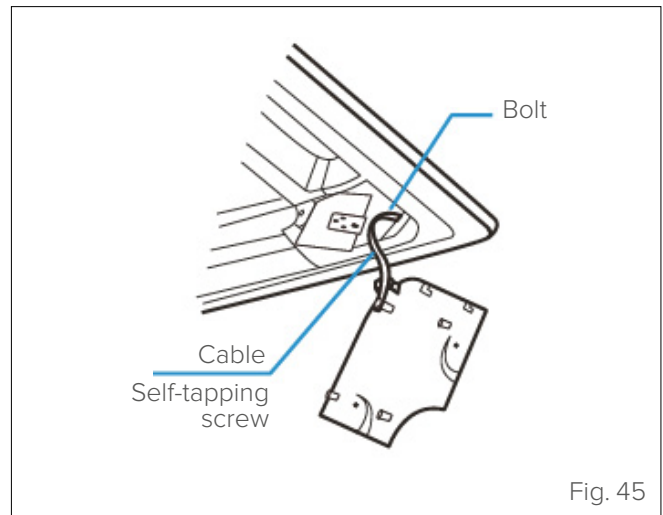

- Slide hooks into the slots

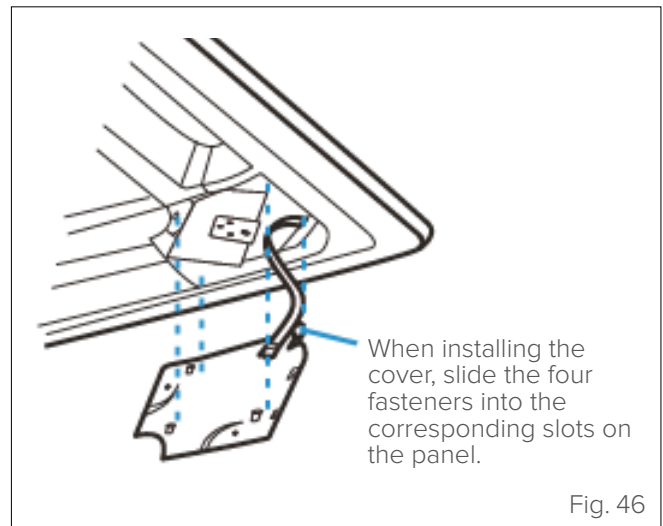

4 CONFIGURATION

4.1 Power setting

Set the board's DIP switch on the internal electrical panel for different applications. Once it has been set, disconnect the main power switch and then reconnect it. If the main switch is not disconnected and then reconnected, the setting will not be applied.

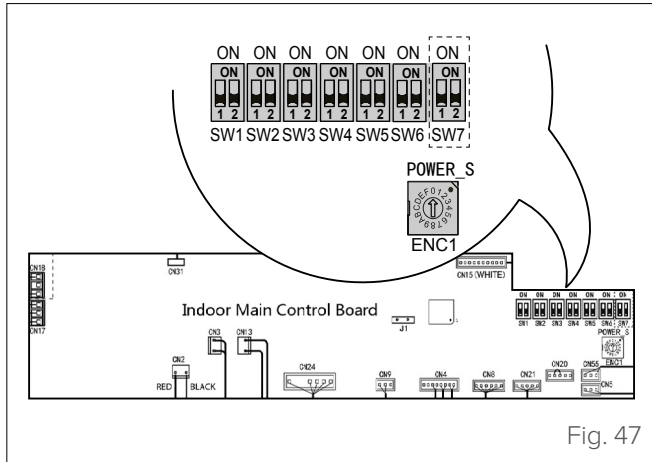
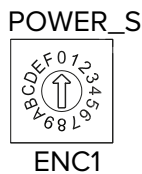

Fig. 47

Key	
	Dip-switch ON (1)
	Dip-switch OFF (0)



ENC1 Power DIP Switch settings:

Toggle switch	Set cooling capacity
Dial code	Cooling capacity
0	2200 W
1	2800 W
2	3600 W
3	4500 W
4	5600 W
5	7100 W
6	8000 W
7	9000 W
8	10000 W
9	11200 W
A	12500 W
B	14000 W



WARNING

The power DIP switches have been configured before delivery. These settings must only be changed by qualified maintenance personnel.

4.2 Address setting

When the indoor unit is connected to the outdoor unit, the outdoor unit will automatically distribute the address to the indoor unit. Or the controller can be used to set the address manually.

- Indoor units can have the same address in the same system.
- The network address and the indoor unit address are the same and do not have to be configured separately.
- Once the address settings have been completed, mark the address on each indoor unit to facilitate after-sales maintenance.
- The centralised controller for the indoor unit is completed on the outdoor unit. For further details, refer to the outdoor unit manual.



















CAUTION





Once the indoor unit has completed the centralised control function on the outdoor unit, the DIP switch on the main control panel of the outdoor unit must be set to auto-addressing; otherwise the indoor units in the system are not controlled by the centralised controller.

- The system can connect up to 64 indoor units (0~63 addresses) simultaneously. Units with the same address can cause a malfunction



4.3 DIP Switch settings on main board

SW1_1	
 [0_]	Cooling mode temperature compensation: 0°C
 [1_]	Cooling mode temperature compensation: 2°C
SW1_2	
 [_0]	EEV in position 96 (step) waiting in heating mode
 [_1]	EEV in position 72 (step) waiting in heating mode
SW2	
 [00]	Factory settings
SW3_1	
 [0_]	Reserved
 [1_]	Indoor unit address deletion
SW3_2	
 [_0]	Reserved
SW4	
 [00]	When the set temperature is reached in heating mode, the fan operates on a 4-minute off / 1-minute on cycle.
 [01]	When the set temperature is reached in heating mode, the fan operates on an 8-minute off / 1-minute on cycle.
 [10]	When the set temperature is reached in heating mode, the fan operates on a 12-minute off / 1-minute on cycle.
 [11]	When the set temperature is reached in heating mode, the fan operates on a 16-minute off / 1-minute on cycle.
SW5	
 [00]	In heating mode, the fan does not operate when the temperature midpoint of the internal heat exchanger is 15°C or lower.

 [01]	In heating mode, the fan does not operate when the temperature midpoint of the internal heat exchanger is 20°C or lower.
 [10]	In heating mode, the fan does not operate when the temperature midpoint of the internal heat exchanger is 24°C or lower.
 [11]	In heating mode, the fan does not operate when the temperature midpoint of the internal heat exchanger is 26°C or lower.

SW6	
 [00]	Heating mode temperature compensation: 6°C
 [01]	Heating mode temperature compensation: 2°C
 [10]	Heating mode temperature compensation: 4°C
 [11]	Heating mode temperature compensation: 0°C

SW7	
 [00]	Reserved

J1	
	Automatic restart function enabled
	Automatic restart function disabled



CAUTION
All DIP switches (including power DIP switches) have been configured before delivery. These settings should only be changed by qualified maintenance personnel.

An incorrect setting of the DIP switch can cause condensation, noise or unexpected system malfunction.

5 RUNNING THE TEST

5.1 Checks to perform before running the test

- Indoor and outdoor units properly installed;
- Correct pipes and wiring;
- No seepage from the refrigerant piping system;
- Correct water drain;
- Full insulation;
- Earth connection correctly connected;
- Piping length adjusted and refrigerant filled up;
- Power supply voltage corresponding to the rated voltage of the air conditioner;
- The inlets and outlets of the indoor and outdoor units are not obstructed;
- The gas and liquid taps of the outdoor unit are open;

When the remote/wired controller is used to set air conditioner cooling, check the following points one by one. In case of fault, refer to troubleshooting in the manual.

5.2 Running the test

- The remote/wired controller function buttons work properly;
- Room temperature control is normal;
- The LED indicator is on;
- Water drainage is normal;

No vibrations or noise during operation

Note: Once the power supply is connected, when the unit is switched on or started immediately after the unit is switched off, the air conditioner uses a protective function that delays compressor start-up

6 USE

6.1 Description of system components

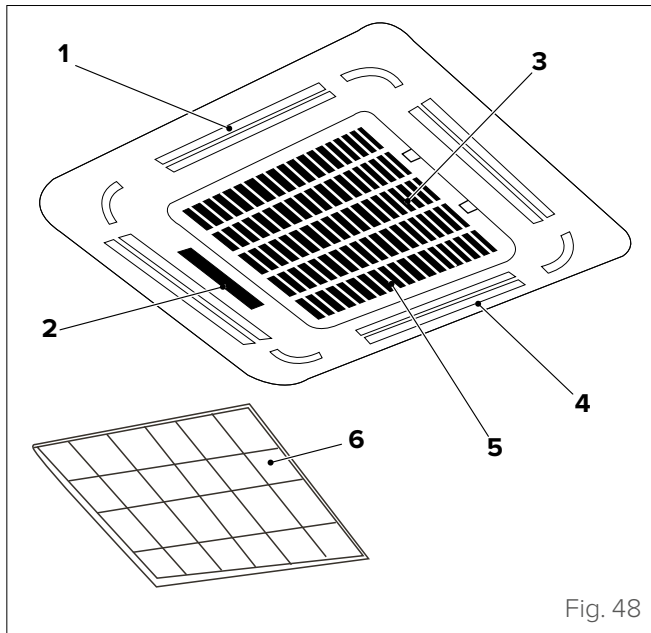

Fig. 48

- 1 Ventilation louver
- 2 Display LED
- 3 Front grille
- 4 Air outlet
- 5 Air inlet



WARNING

The images in this manual are provided for illustrative purposes only. The appearance of your appliance may differ slightly from the illustrations shown here. Refer to the actual characteristics of the unit.



CAUTION DANGER

- If an abnormal condition occurs (e.g. there is a smell of burning), turn the unit off immediately and ask the dealer for assistance to avoid the risk of injury, fire or electrocution.
- DO NOT allow the indoor unit or the remote control to get wet. Humidity can cause an electric shock or a fire risk.
- DO NOT insert fingers, bars or other objects into the air inlet or outlet openings. These operations can be dangerous because the fan can rotate at high speed.
- DO NOT use flammable sprays, such as hairspray or paint, near the unit. These materials can cause fire or combustion.



WARNING

- DO NOT touch the air outlet while the flaps are swinging. Fingers can get trapped or the unit can break down.
- To prevent the appliance from deteriorating, do not use the air conditioner for preservation purposes (food, plants, animals, works of art, etc.).
- DO NOT touch the indoor unit's evaporator coils. The evaporator coils are sharp and can cause personal injury.
- DO NOT place objects that are not resistant to humidity under the indoor unit. A relative humidity of 80% can cause condensate to form.
- DO NOT expose heat generating appliances to cold air and do not place them under the indoor unit. The airflow can cause incomplete combustion, while the heat can cause the unit to deform.
- After long periods of use, check the indoor unit to make sure that it is not damaged. Damage can cause the indoor unit to fall and cause personal injury.
- If the air conditioner is used at the same time as other heating devices, the room must be aired properly to avoid oxygen deficiencies.
- DO NOT use the air conditioner if an insecticidal fumigant is used in the room. The chemicals can be absorbed by the unit and create dangerous situations for people who are hypersensitive to those substances.

6.2 Operation

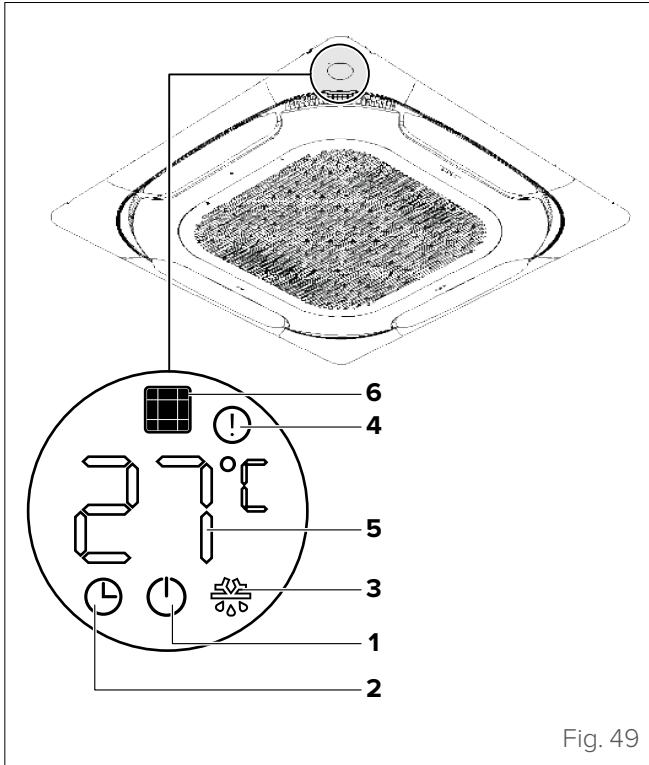

Fig. 49

- 1 Operation indicator
- 2 Timer
- 3 Defrosting indicator
- 4 Alarm indicator
- 5 Display LED
- 6 Infrared receiver

For optimum performance in cooling, heating and dehumidification modes, use the appliance within the temperature ranges below. If the air conditioner is used outside of these ranges, some protective functions may trip and cause suboptimal operation.

	Cooling Mode	Heating Mode
Room temperature	17°C ÷ 32°C	≤27°C

To further optimise unit performance, take the following steps:

- Keep doors and windows closed.
- Limit power consumption using the ON TIMER and OFF TIMER.
- Avoid obstructing air inlets or outlets.
- Inspect and clean the filters regularly.

6.2.1 Meaning of the display codes

Display	Description
	Operation indicator: during normal operation the light is on. If the unit is in stand-by, the light flashes.
	The light turns on if a timer has been set.
	The light turns on if the defrosting function is activated. The display shows the set Temperature.
	The warning light turns on if there is an alarm signal.
	In ventilation mode (FAN), the unit shows room temperature. In other modes, the unit shows the set temperature

6.3 Other functions

– Automatic restart

If the power supply to the unit is interrupted, the unit will automatically restart with the last settings when it is restored.



WARNING

For a detailed explanation of the unit's advanced features, refer to the **Remote Control Manual**.

6.4 Airflow angle control

As hot air rises and cold air falls, the distribution of heated/cooled air in a closed room can be improved by positioning the unit's louvers.

The angle of the louvers can be adjusted by pressing the [SWING] button on the remote control.



WARNING

- During the heating phase, the horizontal air flow will enhance the uneven distribution of the room temperature.
- In Cooling mode, do not leave the ventilation louver at an angle that is too vertical for a prolonged period. In this position condensate may form on the louver fin, which may then fall on the floor and furniture.

Auto-swing

Press SWING to continuously swing the louvers up and down.

Manual swing

Adjust the louvers to enhance the hot or cold effect.

During cooling, adjust the ventilation louvers horizontally.

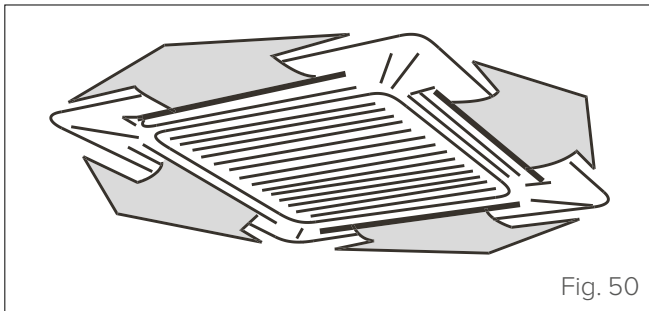

Fig. 50

During heating, adjust the ventilation louvers downwards.

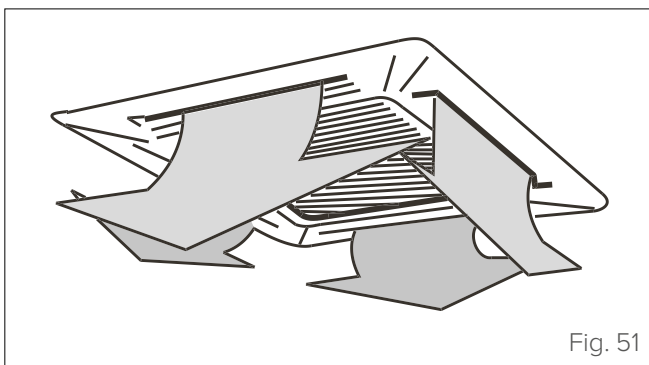

Fig. 51

7 MAINTENANCE

It is good practice to periodically clean both the internal and external parts of the appliance. This guarantees its proper operation and durability.

Carry out periodic maintenance of the appliance in accordance with the regulations in force.

Maintenance must be carried out by qualified technical personnel.

Improper maintenance or service can cause electric shock, fire or water leakage.

7.1 Cleaning the indoor unit



ATTENTION ELECTRIC DANGER

- Before cleaning or maintenance, always switch off the air conditioner and disconnect it from the power supply.
- DO NOT replace blown fuses with fuses of different amps because this could damage the circuit or cause a fire hazard.
- Check that all cables are connected correctly. Incorrectly connecting cables can create a fire or electrocution risk.



CAUTION

- Use only a soft, dry cloth to clean the unit. If the unit is particularly dirty, you can use a cloth moistened in warm water.
- Check that the drain pipe is installed according to the instructions. If it is not, water leaks may occur resulting in material damage and fire and electrocution risks.



IT IS PROHIBITED TO

- use chemicals or chemically treated cloths to clean the unit;
- use benzene, thinners, polishing powders or other solvents to clean the unit. These substances can cause cracking or deformation of the plastic surface;
- use water at temperatures above 40°C to clean the front panel. Very hot water can cause the panel to deform or discolour.

7.2 Cleaning the air filter

The filter stops dust and other particles from entering the indoor unit. A build-up of dust can reduce the efficiency of the air conditioner. For optimal efficiency, clean the air filter every two weeks or, if the zone is very dusty, more frequently. If the filter is very clogged and cannot be perfectly cleaned, it is advisable to replace it.



WARNING

It can be dangerous to remove and clean the filter. Disassembly and maintenance operations must be carried out by certified technical personnel.



CAUTION DANGER

When removing the filter, avoid touching the metal parts of the unit. Sharp metal edges can be sharp.



IT IS PROHIBITED TO

dry the filter by exposing it to direct sunlight. The filter may shrink

- 1 Unlock the grille by pushing the two catches towards the centre at the same time.
- 2 Disconnect the display cable from the electrical panel on the main body.

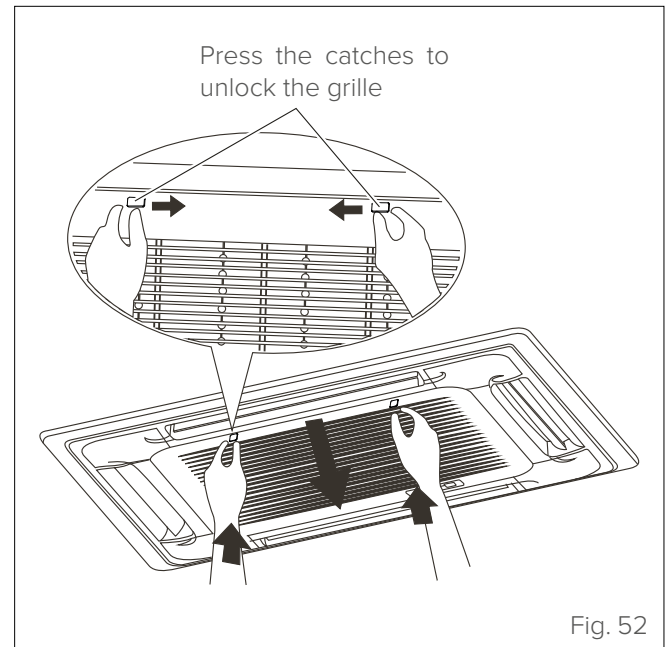

- 3 Detach the grille from the main unit by tilting it 45°, lifting it slightly and then pulling it forward.

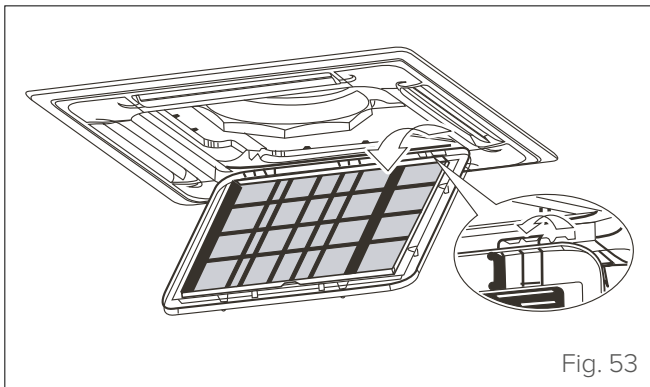

Fig. 53

- 4 Remove the air filter.
- 5 Clean the air filter with a vacuum cleaner or wash it with warm water and a mild detergent.
 - If you use a vacuum cleaner, put the inlet side facing the vacuum cleaner.

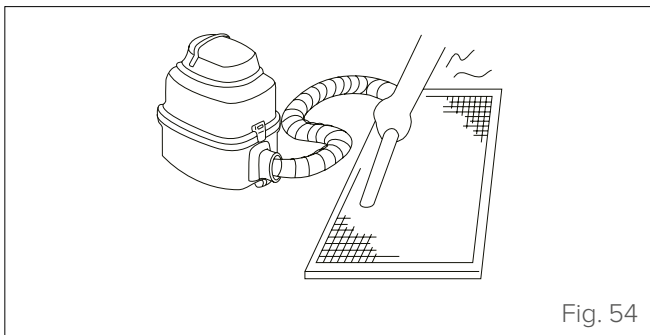

Fig. 54

- If you use water, the inlet side must face downwards, in the opposite direction to the water flow.

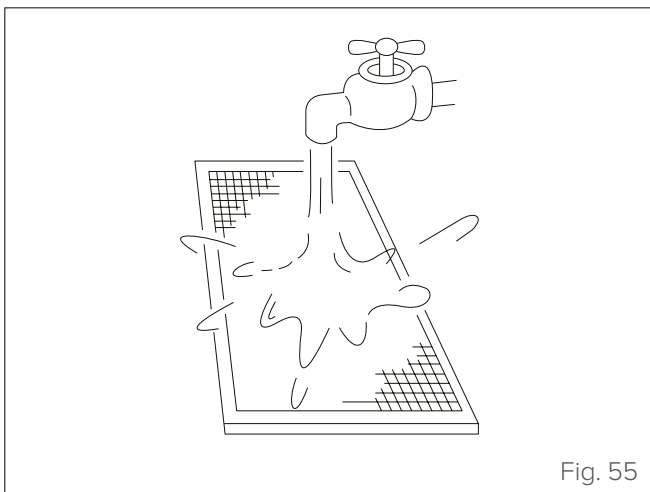
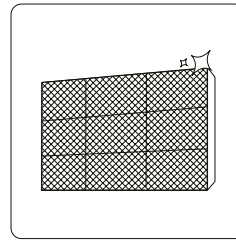

Fig. 55

- 6 Rinse the filter with clean water and let it dry in a cool, dry place, away from direct sunlight.
- 7 Once dry, reinsert the filter into the indoor unit.
- 8 Refit the front grille and reconnect the display cable to the electrical panel on the main body.

7.3 Extended periods of inactivity

If you do not plan to use the air conditioner for an extended period of time, proceed as follows:



Clean all filters

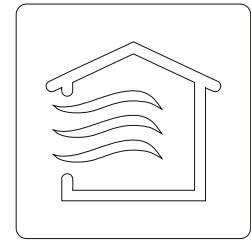

Activate the Ventilation mode until the unit is completely dry (at least 12 hours)

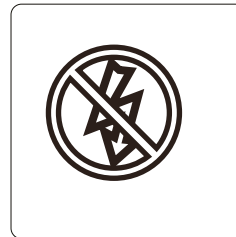

Switch the unit off and disconnect it from the mains power supply

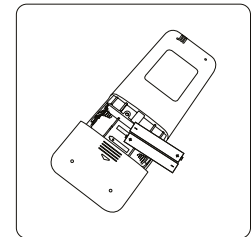

Remove the batteries from the remote control

7.4 Maintenance at the start of the season

After a long period of non-use, or before a period of frequent use, proceed as follows:

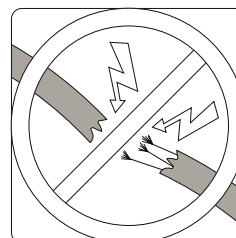

Check that the cables are intact

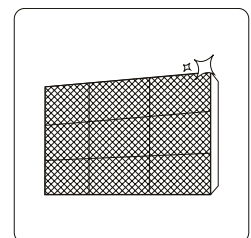

Clean all filters



Check that there are no leaks

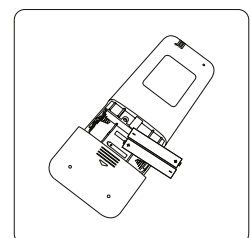

Replace batteries

Remove all obstacles that could block the openings of the indoor and outdoor units.

Clean the air filter and the front grille of the indoor unit. Refit the clean and dry air filter in its original position.

Turn the main power switch on at least 12 hours before switching the unit on.

7.5 Troubleshooting



CAUTION DANGER

If any of the following conditions occur, switch the unit off immediately.

- The power cable is damaged or unusually hot.
- You can smell burning.
- The unit makes loud or abnormal noises.
- A fuse blows or the circuit breaker trips frequently.
- Water or other substance have fallen into the unit, or water or other substance have leaked from the unit.

DON'T TRY TO SOLVE THE PROBLEM YOURSELF. IMMEDIATELY CONTACT AN AUTHORISED SERVICE CENTRE.

7.5.1 Common problems

The problems described below do not represent malfunctions and, in most cases, do not require repair.

Problem	Possible causes
The unit does not switch on when the ON/OFF button is pressed	<ul style="list-style-type: none"> - In order to protect some of the system's components, the system intentionally starts or restarts with a delay of up to 12 minutes under certain operating conditions. If the OPERATION LED lights up on the unit's panel, the system will operate normally and the unit will start after the intentional delay has finished. - The heating mode works, if the "DEF./FAN" LED lights on the panel are on, the indoor unit activates protective measures due to low leaving temperature.
The indoor unit emits a white haze	- In humid regions, a marked difference in temperature between the air in the room and the air conditioning can cause a white mist to form. The phenomenon ceases when the humidity in the room is restored to normal levels.
Both the indoor and outdoor units emit a white haze	- When the unit restarts in Heating mode after a defrosting cycle, it may emit a white haze due to moisture generated by the defrosting process.
Indoor or outdoor unit emits dust	- During a long period of non-use, dust may accumulate on the unit and be emitted when it is turned on again. This problem can be partly solved by covering the unit during prolonged periods of inactivity.
The unit smells bad	<ul style="list-style-type: none"> - The unit may absorb ambient odours (furniture, cooking, cigarettes, etc.) and emit them during operation. - Mold has formed on the unit's filters and must be removed.
Operation is erratic or unpredictable, or the unit does not respond to commands	<p>Interference from mobile phone repeaters and remote amplifiers may cause the unit to malfunction.</p> <p>In this case, try to solve the problem as follows:</p> <ul style="list-style-type: none"> - Disconnect the unit from the power mains and then reconnect it. - Press the ON/OFF button on the remote control to restart operation.

NOTE: if the problem persists, contact your local dealer or nearest service centre, providing a detailed description of the malfunction and specifying the model code.

7.5.2 Anomalies and remedies

If problems occur, please check the following before contacting a service centre.

Anomalies	Possible causes	Remedies
Unsatisfactory cooling performance	The set temperature may be higher than the room temperature	Set a lower temperature
	The heat exchanger of the indoor or outdoor unit is dirty	Clean the heat exchanger (Service Centre)
	The air filter is dirty	Remove the filter and clean it following instructions
	The air inlet or outlet of the indoor or outdoor unit is blocked	Switch the unit off, remove the cause of the obstruction and switch the air conditioner on again
	Open doors and windows	Close doors and windows when using the unit
	Sunlight produces excessive heat	Close curtains and windows during the hottest hours or when the sun is brightest
	Too many heat sources in the room (people, computers, electronic devices, etc.)	Reduce heat sources
	Low refrigerant level due to leakage or prolonged use	Check for leaks, reseal the system if necessary and refill the refrigerant (Service Centre)
The unit does not work	Power failure	Wait for power to be restored
	The power supply switch is off	Unit's power supply. This indoor unit is part of an air conditioning system that has multiple indoor units all connected. The indoor units cannot be powered individually - they are all connected to the same switch.
	The fuse is blown	Replace the fuse (Service Centre)
	Remote control batteries are low	Replace batteries
The unit starts or stops frequently	The amount of refrigerant in the system is excessive or insufficient	Check for leaks and top up the refrigerant (Service Centre)
	Incompressible gas has entered or moisture has penetrated the system	Evacuate the system and recharge the refrigerant (Service Centre)
	The compressor is faulty	Replace the compressor (Service Centre)
	The voltage is too high or too low	Install a voltage controller (Service Centre)
Unsatisfactory heating performance	Cold air enters through doors and windows	Close doors and windows when using the unit
	Low refrigerant level due to leakage or prolonged use	Check for leaks, reseal the system if necessary and refill the refrigerant (Service Centre)
The indicator lights continue to flash	The unit may stop or continue to operate properly. If the indicator lights continue to flash or error codes are displayed, wait approximately 10 minutes. The problem may solve itself. If not, disconnect the unit from the power mains and reconnect it. Switch on the unit. If the problem persists, disconnect the unit from the power supply and contact the nearest service centre.	
An error code appears on the display of the indoor unit: • E0, E1, E2... • P1, P2, P3... • F1, F2, F3...		

NOTE: if, after performing the above checks and diagnostic procedures, the problem persists, switch the unit off immediately and contact an authorised service centre.

7.6 Indoor unit error codes

Error code	Description	Possible causes
E0	Mode conflict	<ul style="list-style-type: none"> – The operating mode of the indoor unit clashes with that of the outdoor units.
E1	Communication error between indoor and outdoor units	<ul style="list-style-type: none"> – Communication cables between indoor and outdoor units are not connected properly. – Interference from high voltage wires or other sources of electromagnetic radiation. – Communication cable too long. – Main PCB is damaged.
E2	Internal air temperature sensor error (T1)	<ul style="list-style-type: none"> – Temperature sensor not connected properly or has malfunctioned. – Main PCB is damaged.
E3	Internal heat exchanger temperature midpoint sensor error (T2)	
E4	Internal heat exchanger leaving temperature sensor error (T2B)	
E6	Fan error	<ul style="list-style-type: none"> – Fan jammed or obstructed. – Fan motor not connected properly or has malfunctioned. – Power supply abnormal. – Main PCB is damaged.
E7	EEPROM error	
Eb	Internal EEV coil error	<ul style="list-style-type: none"> – Loose or broken line. – The electronic expansion valve has jammed. – Main PCB is damaged.
Ed	Outdoor unit faulty	<ul style="list-style-type: none"> – Outdoor unit error.
EE	Water level alarm malfunction	<ul style="list-style-type: none"> – The water level float is stuck. – The water level switch is not connected correctly. – Main PCB is damaged. – The drain pump has malfunctioned.
FE	No address assigned to the indoor unit	<ul style="list-style-type: none"> – No address assigned to the indoor unit.
A1 *	Refrigerant leak	
A0 *	Emergency stop	
F7+ repeated address *	Multiple indoor units with the same address	
U4 *	MS box self-diagnosis error	
F8 *	MS box error	

NOTES:

(*) only for V6R systems

Fast flash = 0.5 s

Slow flash = 1 s

8 DISPOSAL

The manufacturer is registered on the National EEE Register, in compliance with implementation of Directive 2012/19/EU and pertinent national regulations on electrical and electronic equipment waste.

This Directive requires electrical and electronic equipment to be disposed of properly.

Equipment bearing the crossed-out wheelee bin symbol must be disposed of separately at the end of its lifecycle to prevent damage to human health and to the environment.

Electrical and electronic equipment must be disposed of together with all of its parts.

To dispose of “household” electrical and electronic equipment, the manufacturer recommends contacting an authorised dealer or an authorised ecological site.

“Professional” electrical and electronic equipment must be disposed of by authorised personnel through established waste disposal authorities around the country.

In this regard, here is the definition of household WEEE and professional WEEE.

WEEE from private households: WEEE originating from private households and WEEE which comes from commercial, industrial, institutional and other sources which, because of its nature and quantity, is similar to that from private households. Subject to the nature and quantity, where the waste from EEE was likely to have been used by both a private household and users of other than private households, it will be classed as private household WEEE;

Professional WEEE: all WEEE which comes from something other than private households.

This equipment may contain:

- refrigerant gas, the entire contents of which must be recovered in suitable containers by specialised personnel with the necessary qualifications;
- lubrication oil contained in compressors and in the refrigeration circuit to be collected;
- mixtures with antifreeze in the water circuit, the contents of which are to be collected;
- mechanical and electrical parts to be separated and disposed of as authorised.

When the components to be replaced for maintenance purposes are removed or when the entire unit reaches the end of its life and needs to be removed from the installation, waste should be separated by its nature and disposed of by authorised personnel at existing collection centres.



9 ATTACHMENTS

9.1 Indoor unit wiring diagrams

Series	Size
Q4DN-2-XMi	D28 ÷ D80

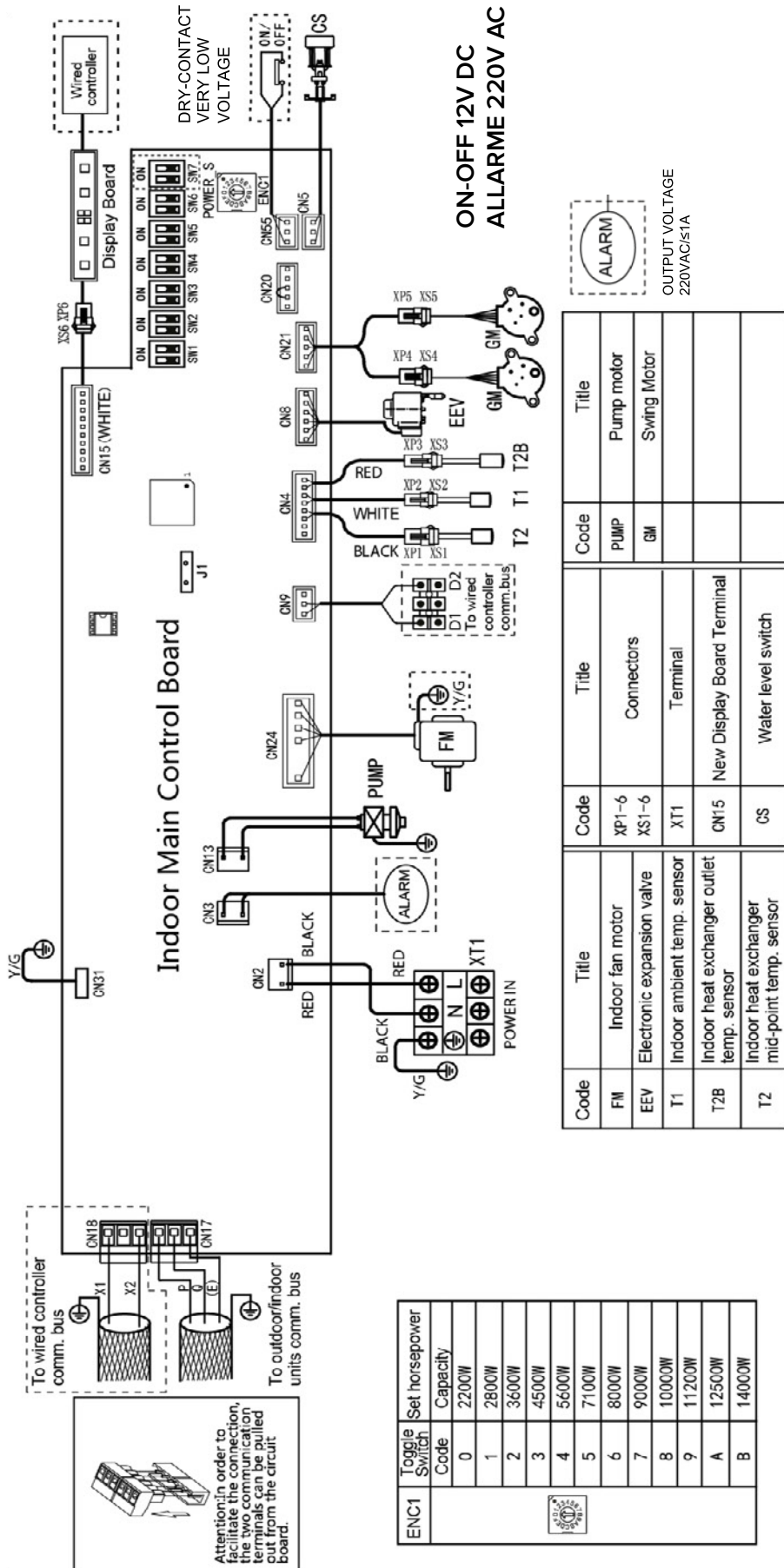

ENC1	Toggle Switch Code	Set horsepower Capacity
	0	2200W
	1	2800W
	2	3600W
	3	4500W
	4	5600W
	5	7100W
	6	8000W
	7	9000W
	8	10000W
	9	11200W
	A	12500W
	B	14000W

Code	Title	Code	Title	Code	Title
FM	Indoor fan motor	XP1-6	Connectors		
EEV	Electronic expansion valve	XS1-6			
T1	Indoor ambient temp. sensor	XT1	Terminal		
T2B	Indoor heat exchanger outlet temp. sensor	CN15	New Display Board Terminal		
T2	Indoor heat exchanger mid-point temp. sensor	CS	Water level switch		

Series	Size
Q4DN-2-XMi	D90 ÷ D140

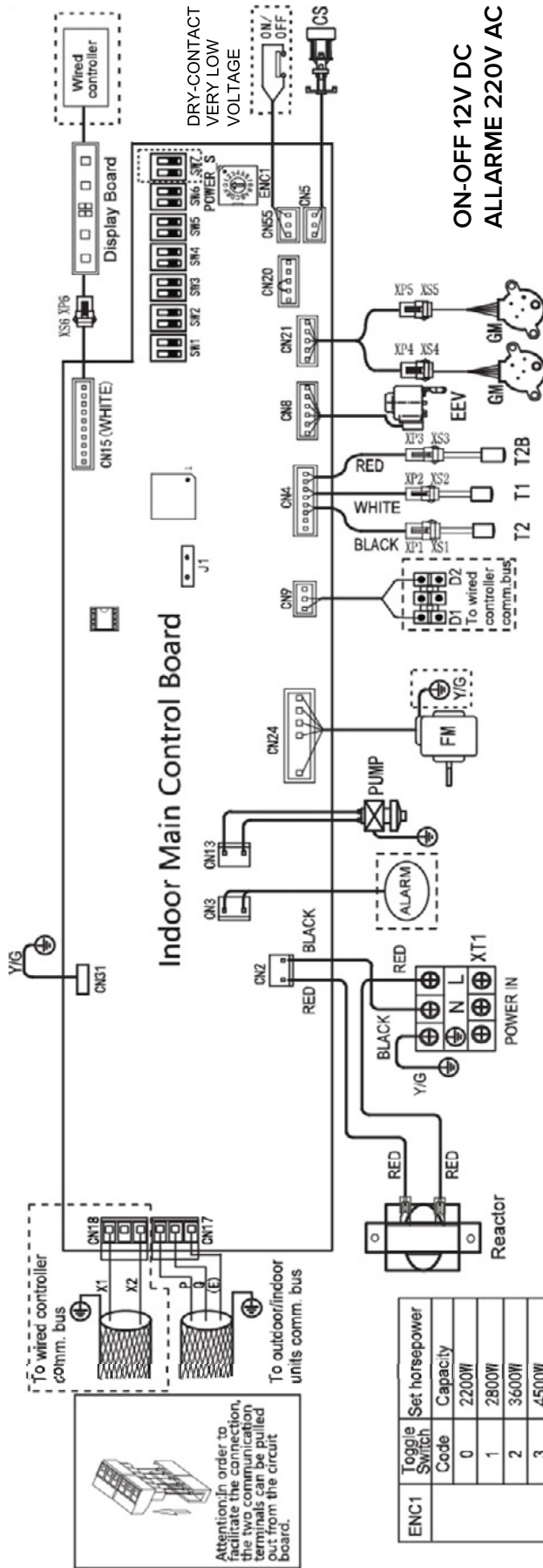

ON-OFF 12V DC
ALLARME 220V AC

Code	Title	Code	Title
FM	Indoor fan motor	XP1-6	Connectors
EEV	Electronic expansion valve	XS1-6	Terminal
T1	Indoor ambient temp. sensor	XT1	New Display Board Terminal
T2B	Indoor heat exchanger outlet temp. sensor	CN15	Water level switch
T2	Indoor heat exchanger mid-point temp. sensor	CS	



OUTPUT VOLTAGE
220VAC/51A

ENC1	Toggle Switch Code	Set horsepower Capacity
	0	2200W
	1	2800W
	2	3600W
	3	4500W
	4	5600W
	5	7100W
	6	8000W
	7	9000W
	8	10000W
	9	11200W
	A	12500W
	B	14000W

9.2 Declaration of conformity



DECLARATION OF CONFORMITY UE

DICHIARAZIONE DI CONFORMITÀ EU
 KONFORMITÄTSEKTLÄRUNG UE
 DECLARATION DE CONFORMITE UE
 DECLARACIÓN DE CONFORMIDAD UE

WE DECLARE UNDER OUR SOLE RESPONSIBILITY THAT THE MACHINE

DICHIARIAMO SOTTO LA NOSTRA SOLA RESPONSABILITÀ CHE LA MACCHINA
 WIR ERKLÄREN EIGENVERANTWORTLICH, DASS DIE MASCHINE
 NOUS DÉCLARONS SOUS NOTRE SEULE RESPONSABILITÉ QUE LA MACHINE
 EL FABRICANTE DECLARA BAJO SU EXCLUSIVA RESPONSABILIDAD QUE LA MÁQUINA

CATEGORY	DIRECT EXPANSION TERMINALS - Heat pump
CATEGORIA	TERMINALI AD ESPANSIONE DIRETTA - Pompa di calore
KATEGORIE	DIREKTVERDAMPFUNGSGERÄTE - Wärmepumpe
CATEGORIE	TERMINAUX À DÉTENTE DIRECTE - Pompe à chaleur
CATEGORIA	TERMINALES POR EXPANSIÓN DIRECTA - Bomba de calor

TYPE / TIPO / TYP / TYPE / TIPO

MODEL	MODEL
Q4DN-2-XMi D28	Q4DN-2-XMi D80
Q4DN-2-XMi D36	Q4DN-2-XMi D90
Q4DN-2-XMi D45	Q4DN-2-XMi D100
Q4DN-2-XMi D56	Q4DN-2-XMi D112
Q4DN-2-XMi D71	Q4DN-2-XMi D140

- **COMPLIES WITH THE FOLLOWING EC DIRECTIVES, INCLUDING THE MOST RECENT AMENDMENTS, AND THE RELEVANT NATIONAL HARMONISATION LEGISLATION CURRENTLY IN FORCE:**
- RISULTA IN CONFORMITÀ CON QUANTO PREVISTO DALLE SEGUENTI DIRETTIVE CE, COMPRESSE LE ULTIME MODIFICHE, E CON LA RELATIVA LEGISLAZIONE NAZIONALE DI RECEPIMENTO:
- DEN IN DEN FOLGENDEN EG-RICHTLINIEN VORGESEHENEN VORSCHRIFTEN, EINSCHLIEßLICH DER LETZTEN ÄNDERUNGEN, SOWIE DEN ANGEWANDTEN LANDESGESETZEN ENTSPRICHT:
- EST CONFORME AUX DIRECTIVES CE SUIVANTES, Y COMPRIS LES DERNIÈRES MODIFICATIONS, ET À LA LÉGISLATION NATIONALE D'ACCUEIL CORRESPONDANTE:
- ES CONFORME A LAS SIGUIENTES DIRECTIVAS CE, INCLUIDAS LAS ÚLTIMAS MODIFICACIONES, Y A LA RELATIVA LEGISLACIÓN NACIONAL DE RECEPCIÓN:

- 2006/42/EC** **machinery directive**
 direttiva macchine
 Maschinenrichtlinie
 directive sur les machines
 directiva máquinas
- 2014/30/UE** **electromagnetic compatibility**
 compatibilità elettromagnetica
 Elektromagnetische Verträglichkeit
 compatibilité électromagnétique
 compatibilidad electromagnética
- 2009/125/CE** **Ecodesign /Progettazione ecocompatibile / Ecodesign / Éco-conception / Ecodiseño**
- 2011/65/UE** **RoHs**

-Unit manufactured and tested according to the followings Standards:
 -Unità costruita e collaudata in conformità alle seguenti Normative:
 -Unité construite et testée en conformité avec les Réglementations suivantes
 -Unidad construida y probada de acuerdo con las siguientes Normativas
 -Gebautes und geprüftes Gerät nach folgenden Normen

EN 60335-1 :2012/A13 :2017 EN 60335-2-40 :2003/A13 :2012
 EN 62233 :2008 EN 61000-6-1 :2007 EN 61000-6-3 :2007/A1 :2011
 EN 62321-1 :2013 EN 62321-2 :2014 EN 62321-3-1 :2014
 EN 62321-4 :2014 EN 62321-5 :2014 EN 62321-6 :2015
 EN 62321-7-1 :2015 EN 62321-7-2 :2017 EN 62321-8 :2017

-Responsible to constitute the technical file is the company n°.00708410253 and registered at the Chamber of Commerce of Belluno Italy
 -Responsabile a costituire il fascicolo tecnico è la società n° 00708410253 registrata presso la Camera di Commercio di Belluno Italia
 -Verantwortliche für die technischen Unterlagen zusammenstellen n° 00708410253 ist das Unternehmen bei der Handelskammer von Belluno Italien registriert
 -Responsable pour compiler le dossier technique est la société n°00708410253 enregistrée à la Chambre de Commerce de Belluno en Italie
 -Encargado de elaborar el expediente técnico es la empresa N ° 00708410253 registrada en la Cámara de Comercio de Belluno Italia

FELTRE, **29/10/2018**

NAME / NOME / VORNAME / PRÉNOM / NOMBRE
 SURNAME / COGNOME / ZUNAME / NOM / APELLIDOS
 COMPANY POSITION / POSIZIONE / BETRIEBSPOSITION / FONCTION / CARGO LEGALE RAPPRESENTANTE

STEFANO
BELLÒ

FOR 30 YEARS WE HAVE BEEN OFFERING
SOLUTIONS FOR SUSTAINABLE COMFORT
AND THE WELL-BEING OF PEOPLE AND
THE ENVIRONMENT

www.clivet.com

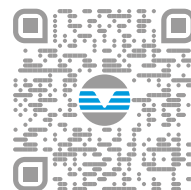

sales and service



CLIVET SPA
Via Camp Lonc 25, Z.I. Villapaiera
32032 Feltre (BL) - Italy
Tel. +39 0439 3131 - Fax +39 0439 313300
info@clivet.it

A Group Company of

