



# High Temperature Hydro Module

HWM-2-XMI 140



TECHNICAL BULLETIN



# CONTENTS

<b>1 External Appearance .....</b>	<b>3</b>
<b>2 Nomenclature .....</b>	<b>3</b>
<b>3 System Schematic .....</b>	<b>4</b>
<b>4 Specifications .....</b>	<b>5</b>
<b>5 BOM .....</b>	<b>7</b>
<b>6 Dimensions .....</b>	<b>9</b>
<b>7 Unit Installation .....</b>	<b>16</b>
<b>8 Application Examples .....</b>	<b>30</b>
<b>9 Pump Model Selection .....</b>	<b>43</b>
<b>10 Selection of Expansion Tank Volume and Preset Pressure .....</b>	<b>44</b>
<b>11 Final Check and Test Run .....</b>	<b>45</b>
<b>12 Piping Design .....</b>	<b>46</b>
<b>13 Wiring Diagram .....</b>	<b>47</b>
<b>14 Sound Levels .....</b>	<b>48</b>
<b>15 Accessories .....</b>	<b>50</b>



## 1 External Appearance

Figure 1.1: Appearance



## 2 Nomenclature

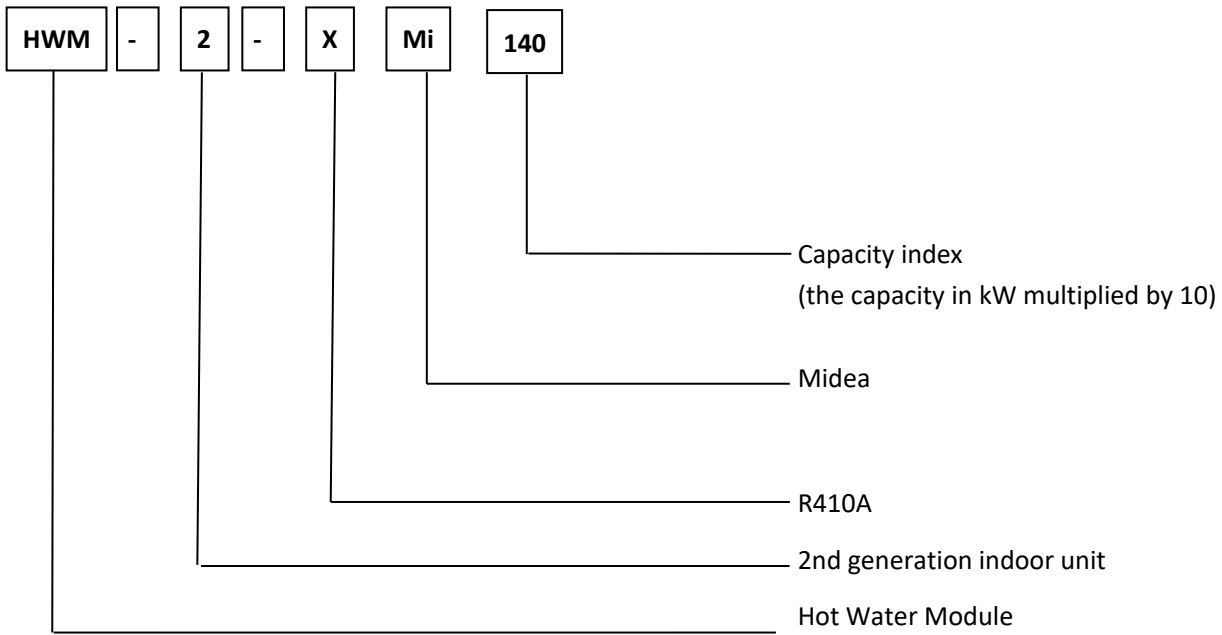

## 3 System Schematic

The following picture shows a schematic diagram using the High Temperature Hydraulic module in a VRF MV6R system. The below picture is just an example reporting all units which can be connected to VRF MV6R series outdoor units, please check its relative technical documentation for further information.

Figure 3.1: Hydraulic box connection method

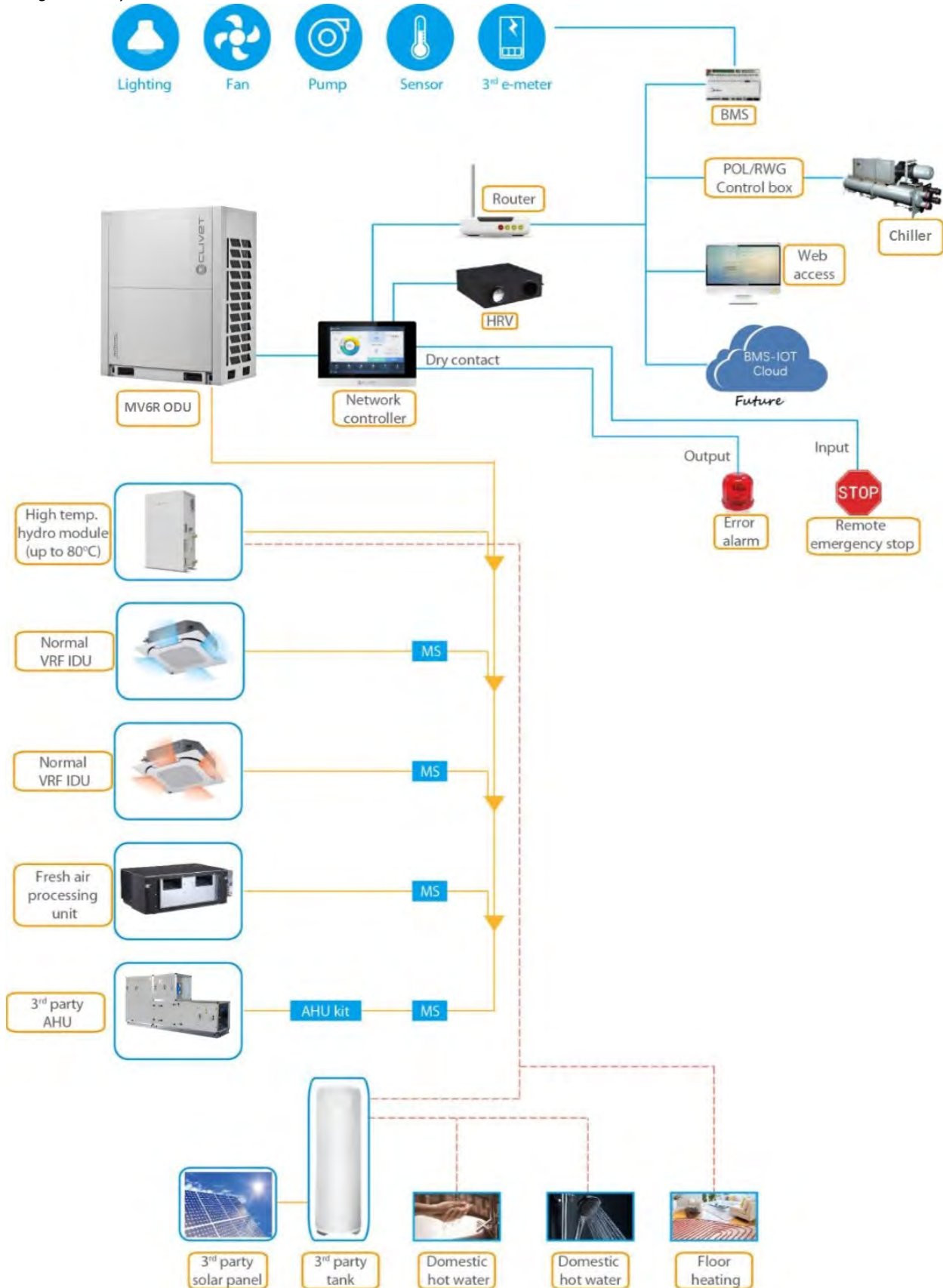

## 4 Specifications

Specification	Standard	Unit	Value
<b>Heating capacity</b>	Rated	kW	14
	Water outlet : 45°C, inlet 40°C		
	Outdoor air : 7°C DB / 6°C WB		
<b>Casing</b>	Colour		Polar white
<b>Net Dimensions</b>	Height	mm	795
	Width	mm	450
	Depth	mm	300
<b>Packaging Dimensions</b>	Height	mm	940
	Width	mm	748
	Depth	mm	390
<b>Weight</b>	Unit	kg	63
	Packed unit	kg	71
<b>Water Flow Rate</b>	Minimum	m <sup>3</sup> /h	1.2
	Nominal	m <sup>3</sup> /h	2.4
	Maximum	m <sup>3</sup> /h	2.9
<b>Water circuit</b>	Inlet piping connection diameter	mm	25.4
	Outlet piping connection diameter	mm	25.4
	Connection type		External screw thread
<b>Design pressure</b>	Allowed water pressure	Mpa	0.1~0.3
	R410a	Mpa	4
	R134a	Mpa	3.1
<b>R134a refrigerant circuit</b>	Refrigerant type		R-134a
	Refrigerant charged volume	kg	1.2
	Oil type		FV50S
	Oil charged volume	L	0.4
<b>R410a refrigerant circuit</b>	Gas piping connection diameter	mm	12.7
	Liquid piping connection diameter	mm	9.52
	Connection type		Welding
<b>Sound pressure level</b>	Nom.	dB (A)	43
<b>Sound Power Level</b>	Nom.	dB (A)	54
<b>Heating Operation Range</b>	Ambient, Min	°C	-20
	Ambient, Max	°C	30
	Water Side, Min	°C	25
	Water Side, Max	°C	80
<b>Domestic Hot Water Operation Range</b>	Ambient, Min	°C	-20
	Ambient, Max	°C	43
	Water Side, Min	°C	25
	Water Side, Max	°C	80

Specification	Standard	Unit	Value
<b>Refrigerant side heat exchanger</b>	Type		Plate heat exchanger
	Quantity		1
	Plate	Pieces	76
<b>Water side heat exchanger</b>	Type		Plate heat exchanger
	Quantity		1
	Plate	Pieces	38
<b>Unit Location</b>	Ambient, Min-Max	°C	0~40
<b>Installation place</b>			Indoor only
<b>Power supply</b>	Phase		1-ph
	Frequency	Hz	50/60
	Voltage	V	220 ~ 240
	Voltage Range, Min/Max	%	± 10
<b>Current Amperes</b>	Maximum running current (MCA)	A	16
	Recommended Fuse	A	20

Note:

\*Nominal heating conditions

inlet water temperature: 40 °C

water flow rate: 2.4 m<sup>3</sup>/h

Outdoor Temp. : 7°C DB/6°C WB

\*The water circuit must use the closed circuit.

\*Please do not use it as a drinking water.

\*Due to continuing improvement, the above specifications may be subject to change without notice.

\*Please don't use the steel material for the water piping material.

\*Please always make water circulate or pull out the circulation water completely when not using it.

\*Please do not use groundwater and well water.



5 BOM

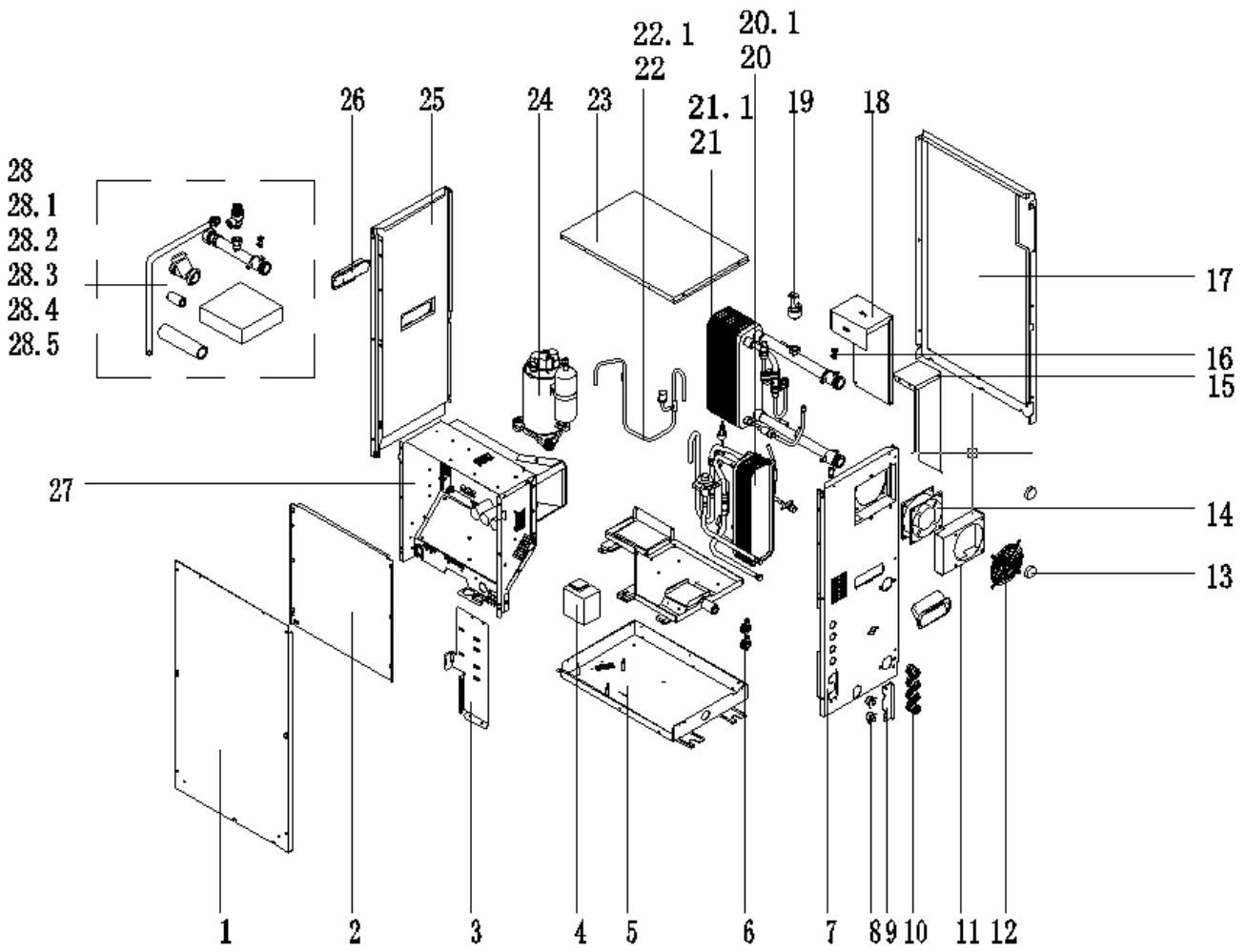

Engineering Data



<b>1</b>	<b>Front panel assembly</b>
<b>2</b>	Electric control box cover assembly
<b>3</b>	Connecting plate
<b>4</b>	Pearl cotton
<b>5</b>	Chassis assembly
<b>6</b>	Pressure pipe clamp
<b>7</b>	Right panel assembly
<b>8</b>	Rubber washer
<b>9</b>	Connecting plate
<b>10</b>	Cable gland
<b>11</b>	Connecting plate
<b>12</b>	Grill
<b>13</b>	Dust plug
<b>14</b>	AC fan
<b>15</b>	Connecting plate
<b>16</b>	Drainage pipe adapter
<b>17</b>	Rear panel assembly
<b>18</b>	Connecting plate assembly
<b>19</b>	Flow Switch (RoHS)
<b>20</b>	Plate heat exchanger assembly
<b>20.1</b>	Plate heat exchanger assembly
<b>21</b>	Plate heat exchanger assembly
<b>21.1</b>	Plate heat exchanger assembly
<b>22</b>	Air discharge pipe assembly
<b>22.1</b>	Pressure switch
<b>23</b>	Top cover assembly
<b>24</b>	DC Inverter rotary compressor
<b>25</b>	Left panel assembly
<b>26</b>	Handle
<b>27</b>	E-part box assembly
<b>27.1</b>	Power drive mounting plate assembly
<b>27.2</b>	Hydraulic module, Main control board assembly
<b>27.3</b>	Wire joint
<b>28</b>	Accessory package
<b>28.1</b>	Connecting pipe assembly
<b>28.2</b>	Y shape filter
<b>28.3</b>	Accessory- Drainage hose
<b>28.4</b>	Wired controller
<b>28.5</b>	Magnetic ring
<b>29</b>	Water temperature sensor
<b>30</b>	Water temperature sensor
<b>31</b>	Pipe Temperature Sensor
<b>32</b>	Pipe Temperature Sensor
<b>33</b>	Pipe Temperature Sensor

6 Dimensions

6.1 Structural Dimensions

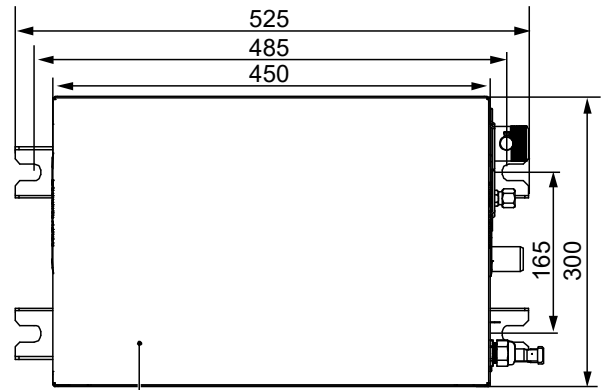
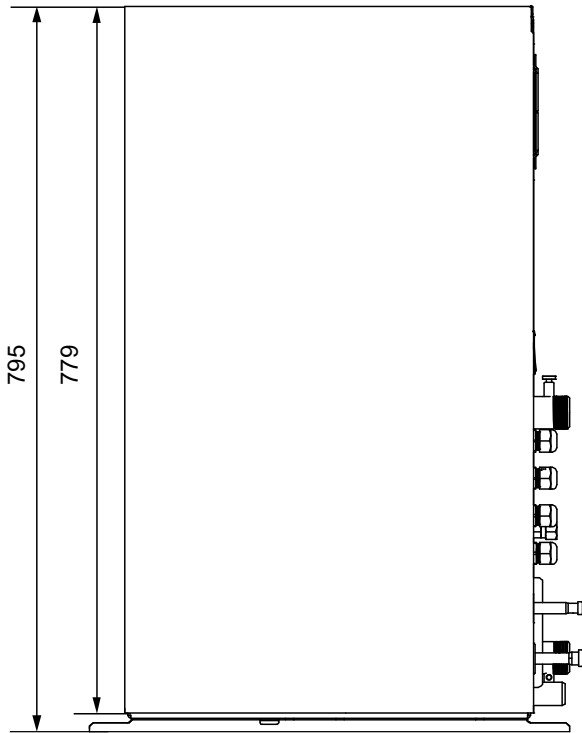

Hydro module unit (top view)

## 6.2 Center of gravity

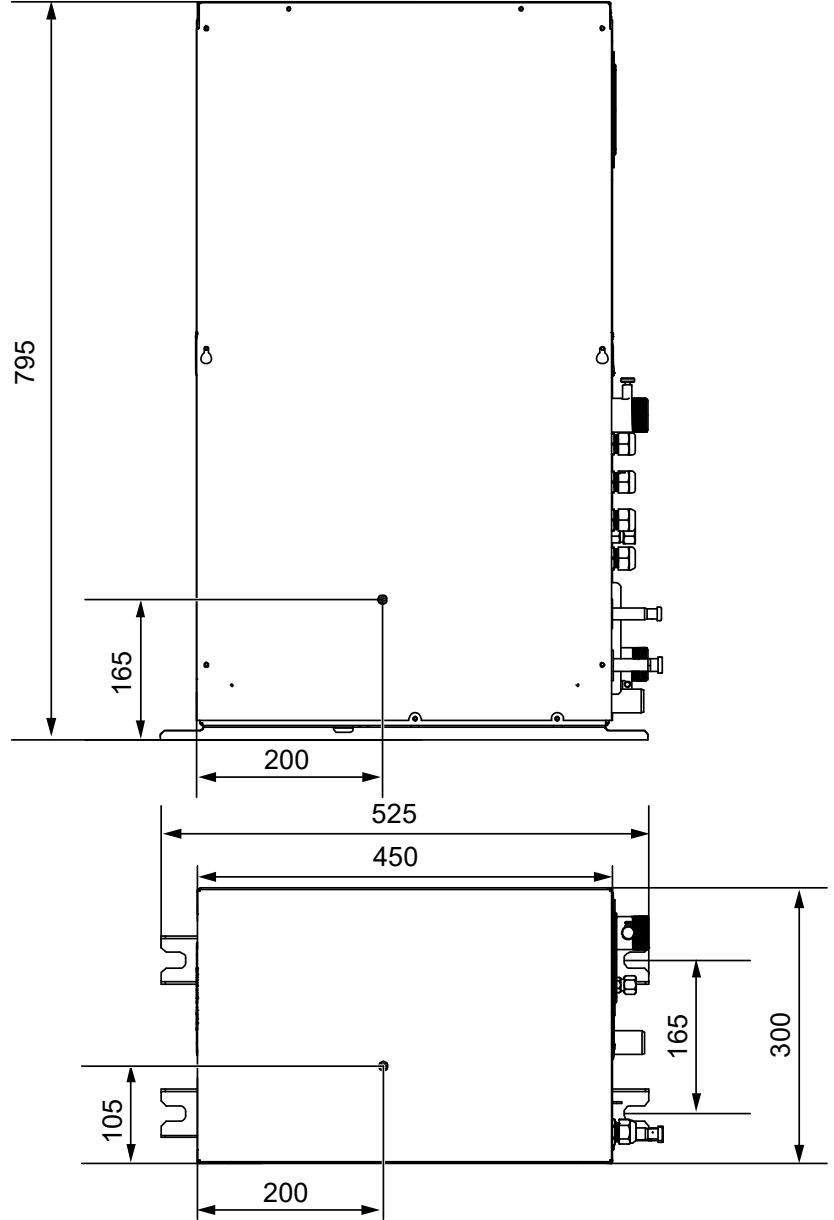
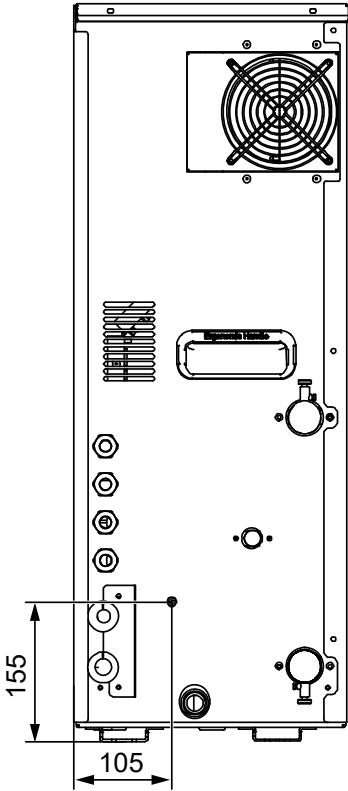

6.3 Installation Space

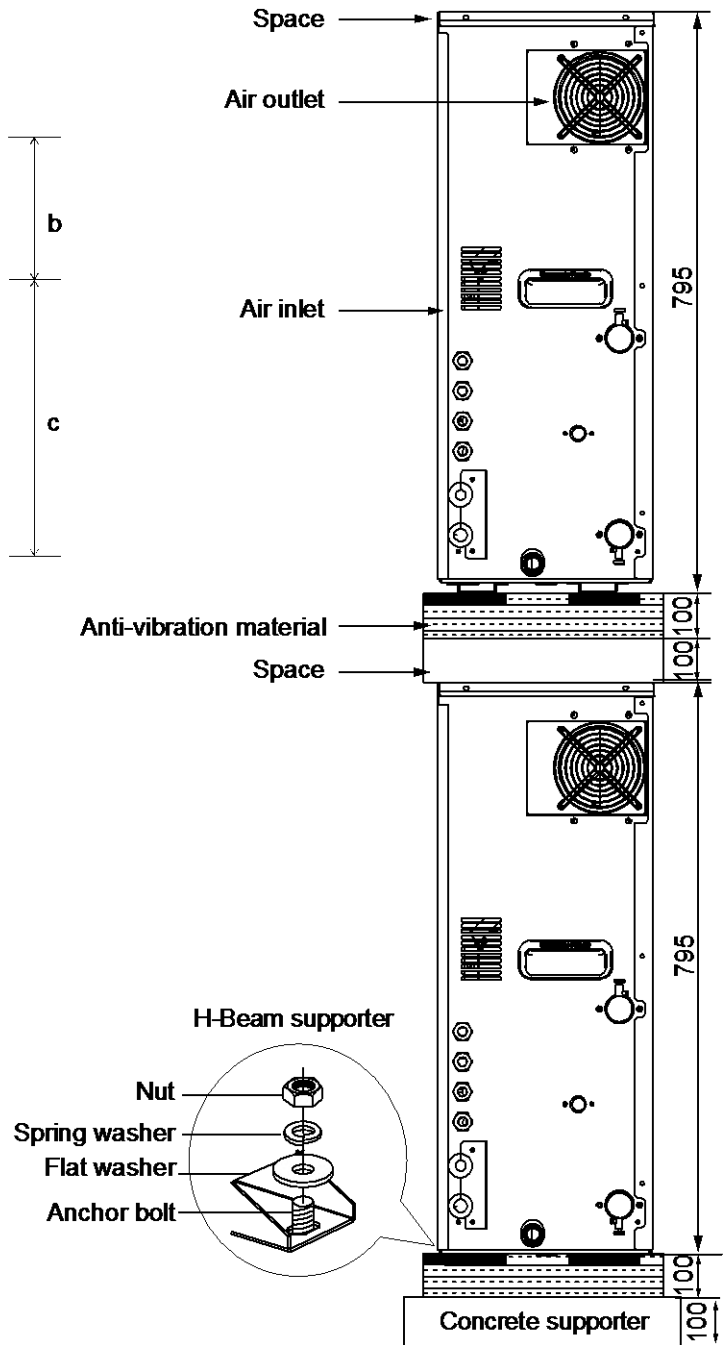
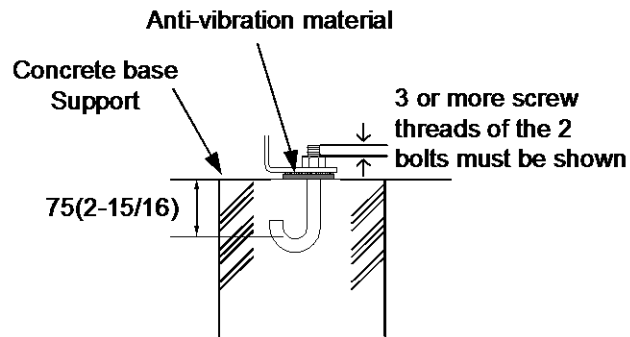
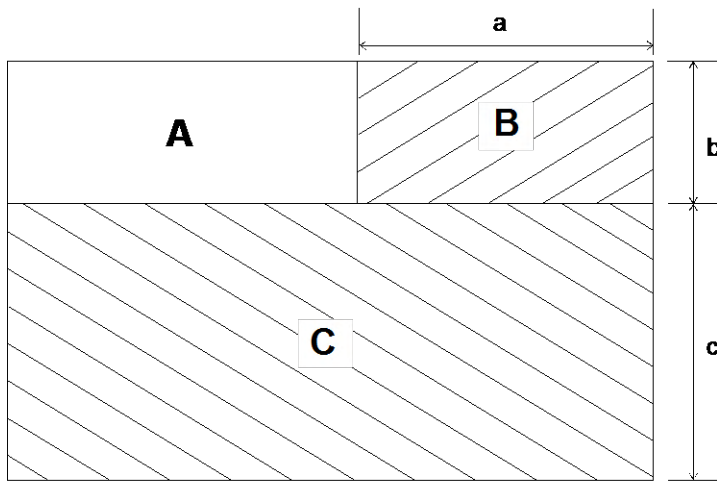

Engineering Data

A	High Temperature Hydraulic module
B	Space for installing piping (on the right side)
C	Space for installation and maintenance (in the front)

## 6.4 General Precautions about Installation Site

Select an installation site that meets the following conditions:

- The floor that supports unit weight should be hard enough. The floor should be level to avoid vibration and noise.
- The space around the unit should be wide enough for maintenance and repair. The space dimensions are as follows:  $a \geq 400$  mm;  $b \geq 300$  mm;  $c \geq 600$  mm. If double-layer installation is required, the upper and lower space between units should be not less than 150 mm.
- There should be enough space around the unit for ventilation.
- If flammable gas leaks, ensure that there are no hazards that could lead to fire.
- This unit is not designed to operate in an environment where explosions could occur.
- Select the installation site according to the corresponding legal provisions. The noise should not affect any person. Carefully select an installation site. Do not install the unit in an environment that is sensitive to sound, such as living rooms and bedrooms.
- If water leaks, the leakage should not cause damage to the installation site or the surroundings.
- Take enough measures according to the corresponding legal provisions to deal with refrigerant leakage.
- When the unit is installed in a small room, take measures to ensure that concentration of the leaking refrigerant cannot exceed the allowed limit.
- Do not climb, sit on, or stand on the unit.
- Do not place any article or equipment on the top of the unit (top panel of the unit).
- Do not install the unit in a workshop, for example, a construction site, because at construction sites, the equipment will be covered in dust.
- Do not install the unit in a highly damp site, such as a restroom. (The maximum relative humidity is 85%.)
- When installing the unit, reserve enough space for the air inlet and air outlet. Do not obstruct them.

### Notes for installers and service engineers

#### Caution

In an airtight space, excessively high concentration of the refrigerant may lead to insufficient oxygen.

## 6.5 General precautions about the Water System

Check the following items before continuing installation:

- Max. hydraulic pressure: 10 bar
- Max. water temperature: 80 °C
- Install enough safety devices in the water loops to ensure that the hydraulic pressure does not exceed the maximum operating pressure (10 bar).
- Provide a drainage hole at all the low points of the system so that the water is completely drained from the water system when you repair or maintain the unit. A drain valve has been installed at the water inlet to facilitate water discharge from the unit's water system.
- Ensure that you have provided a suitable water discharge pipe to the safety valve to prevent water from coming into contact with any electrical part. A water discharge pipe has been provided with the unit.
- You must deploy air outlets at all the high points of the system. The air outlets should be deployed at the places where they can be easily maintained. A drain valve has been installed at the water outlet to facilitate air discharge from the unit's water system.
- Ensure that all the components installed on pipes on site can bear water pressure and water temperature.
- You should use materials that are compatible with water and equipment in the system.
- Anti-freezing protection of the water system:
- Freezing may cause damage to the system. The ODU may be exposed to temperatures below 0 C. You must prevent the system from freezing.
- All the internal water systems are insulated to prevent heat loss. On site, pipes should be fitted with insulating materials.
- The unit is designed with an anti-freezing function. The unit uses a heat pump to prevent the entire system from freezing. When the water temperature in the system decreases to a certain value, the unit will heat water. The anti-freezing function will be disabled only when the water temperature rises to a certain value.
- In the event of power failure, the anti-freezing function cannot protect the unit from freezing.
- Using anti-freezing liquid in the water system is recommended, because power failure may happen when no one is present.
- Ensure that the water system is full of the ethylene glycol concentration provided in the following table, according to the expected lowest outdoor temperature. When ethylene glycol is added to the system, device performance will be affected. The following table lists the correction coefficients of the unit capacity, flow, and pressure drop of the system.

<i>Ethylene Glycol</i>					
Quality of Glycol %	Modification Coefficient				Freezing Point in degree C
	Cooling Capacity Modification	Power Modification	Water Resistance	Water Flow Modification	
<b>0</b>	1.000	1.000	1.000	1.000	0.0000
<b>10</b>	0.984	0.998	1.118	1.019	-4.000
<b>20</b>	0.973	0.995	1.268	1.051	-9.000
<b>30</b>	0.965	0.992	1.482	1.092	-16.000
<b>40</b>	0.960	0.989	1.791	1.145	-23.000
<b>50</b>	0.950	0.983	2.100	1.200	-37.000

<i>Propylene Glycol</i>					
Quality of Glycol %	Modification Coefficient				Freezing Point in degree C
	Cooling Capacity Modification	Power Modification	Water Resistance	Water Flow Modification	
0	1.000	1.000	1.000	1.000	0.0000
10	0.976	0.996	1.071	1.000	-3.000
20	0.961	0.992	1.189	1.016	-7.000
30	0.948	0.988	1.380	1.034	-13.000
40	0.938	0.984	1.728	1.078	-22.000
50	0.925	0.975	2.150	1.125	-35.000

- If ethylene glycol is not added, water must be discharged when power is cut off

## 6.6 Checking, Handling and Unpacking the Unit

- When the unit is delivered, you must check the equipment and immediately report damage (if any) to the claims agent of the carrier.
- Put the packaged unit as close as possible to its final installation site to prevent damage during the handling process.
- Check all the accessories of the IDU. (For details, see “1. Accessories” on page 1.)

### Notes for installers and service engineers

#### Caution

- Remove the plastic packaging bag so that children cannot play with it. Children may face the danger of death by suffocation if playing with the plastic packaging bag.
- Both ethylene glycol and propylene glycol are toxic substances. The concentration mentioned in the preceding table cannot prevent freezing, but can prevent breaking caused by liquid pressure.



6.7 Installation Diagram

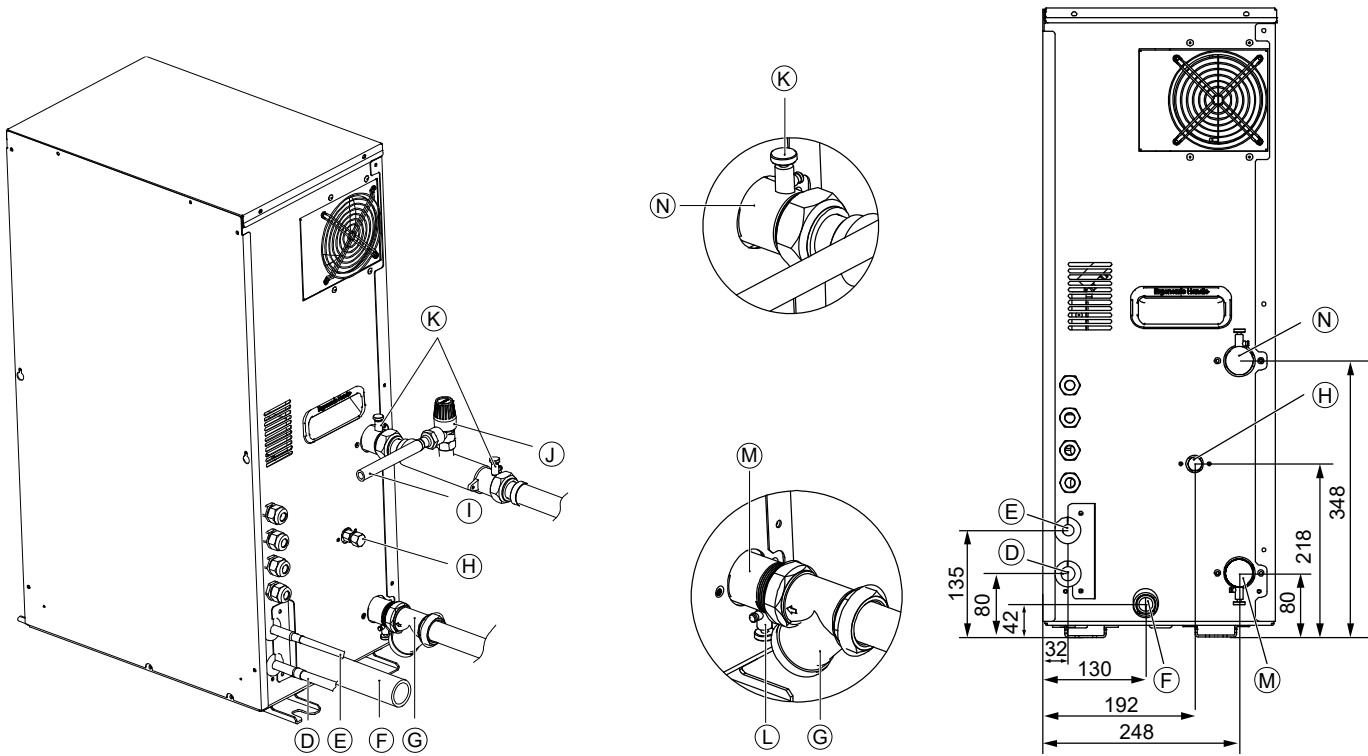

- Ⓓ Liquid pipe (connected to the ODU)
- Ⓔ Gas pipe (connected to the ODU)
- Ⓕ Water discharge pipe (drainage pan)
- Ⓖ Y-shaped filter
- Ⓗ Access hole (for charging/discharging refrigerant)
- Ⓛ Water discharge pipe (safety valve)
- Ⓜ Safety valve
- Ⓚ Discharge valve
- Ⓝ Water inlet
- Ⓛ Drain valve
- Ⓝ Water outlet

## 7 Unit Installation

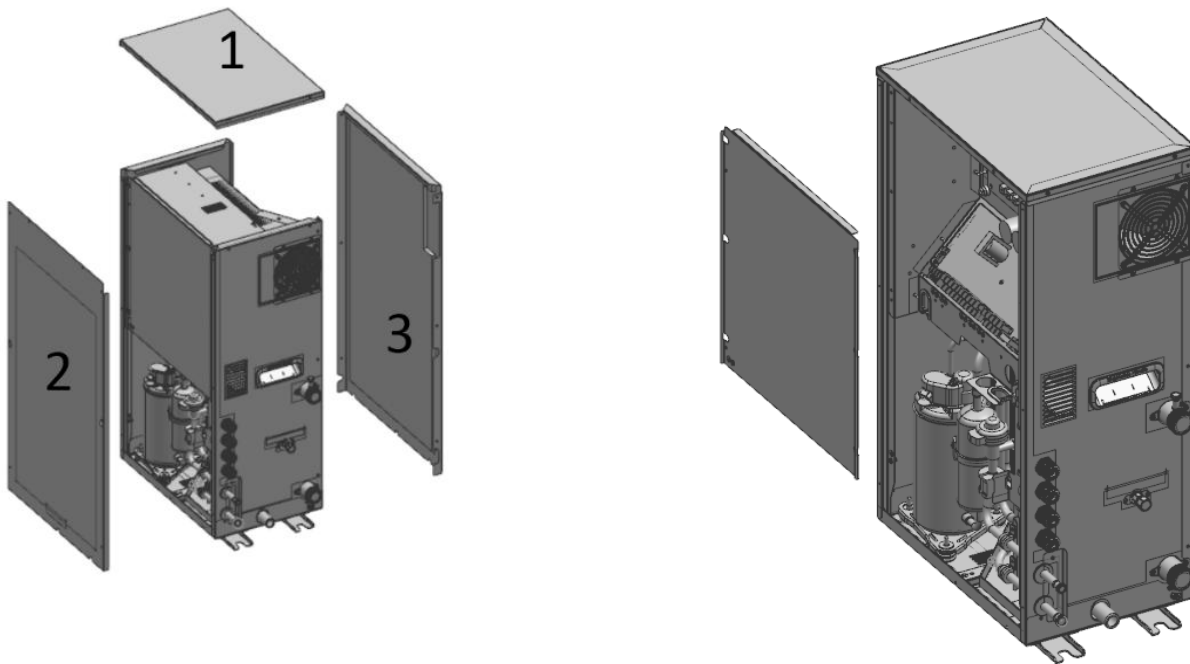

### Notes for installers and service engineers

#### Caution

The unit should be installed by professional installation operators. Material selection and installation must confirm with the local legal provisions.

- To check the interior of the unit, open the top panel, front panel, and rear panel first. After you open these three panels, you can see the main parts of the unit. If you just install or maintain the internal parts of the electric control box, you need to open the front panel without needing to open the top or rear panel.

- 1 Top panel
- 2 Front panel
- 3 Rear panel

To open the electric control box and operate the interior of the electric control box, open the electric control box cover plate. To open the electric control box, you can open the front panel without needing to open the top or rear panel.

## Main parts of the unit

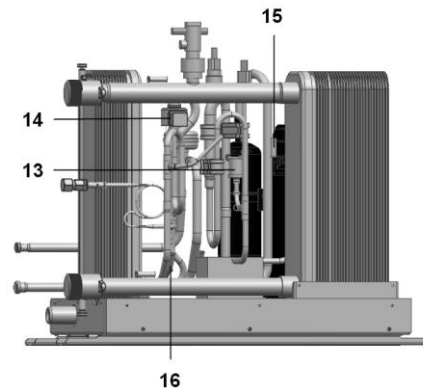
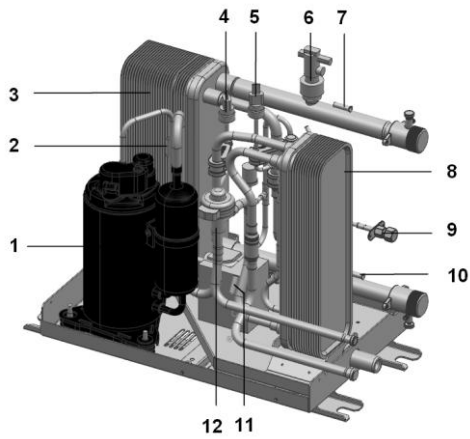

<b>1</b>	<b>Compressor</b>	<b>9</b>	<b>Access hole</b>
<b>2</b>	Discharge temperature sensor	<b>10</b>	Water inlet temperature sensor
<b>3</b>	Plate heat exchanger used by the condenser	<b>11</b>	Liquid pipe temperature sensor at the outlet on the R410A refrigerant side
<b>4</b>	Low pressure sensor	<b>12</b>	Electronic expansion valve on the R410A loop
<b>5</b>	High pressure sensor	<b>13</b>	High pressure switch
<b>6</b>	Water flow switch	<b>14</b>	Electronic expansion valve on the R134a loop
<b>7</b>	Water outlet temperature sensor	<b>15</b>	Suction temperature sensor
<b>8</b>	Plate heat exchanger used by the evaporator	<b>16</b>	Cold outlet temperature sensor on the R134a refrigerant side

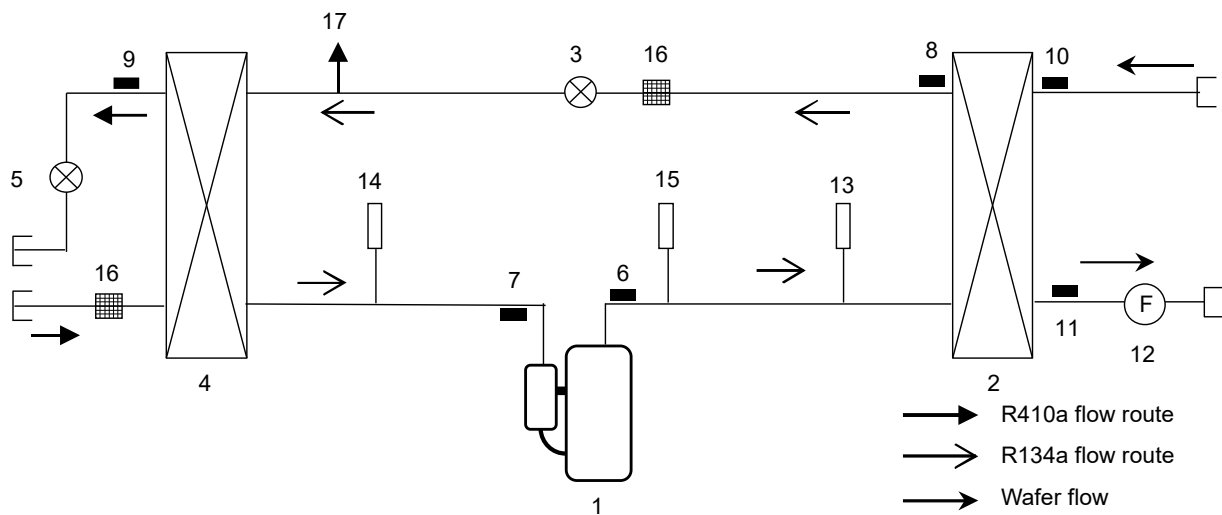

1	Compressor	10	Water inlet temperature sensor
2	Plate heat exchanger used by the condenser	11	Water outlet temperature sensor
3	Electronic expansion valve on the R134a loop	12	Water flow switch
4	Plate heat exchanger used by the evaporator	13	High pressure sensor
5	Electronic expansion valve on the R410A loop	14	Low pressure sensor
6	Discharge temperature sensor	15	High pressure switch
7	Suction temperature sensor	16	Filter
8	Cold outlet temperature sensor on the R134a refrigerant side	17	Access hole
9	Liquid pipe temperature sensor at the outlet on the R410A refrigerant side		

- Connecting pipes on the refrigerant side and water system side
- Use screw thread to connect the pipe on the water system side. Tighten the pipe to avoid water leakage.
- Brazing is required on the refrigerant side.

## Notes for installers and service engineers

### Brazing Precautions

- In the event of brazing, please use nitrogen for sweeping. This can prevent the occurrence of oxidation inside pipes. Oxidation will have adverse effects on the valves and compressors in the cooling system, and may hamper normal operations.
- Use the pressure relief valve to set the nitrogen pressure to 0.02 MPa (a pressure that can just be felt by the skin).
- Do not use antioxidants when brazing pipe connectors. Residues will block pipes and damage equipment.
- Do not use a flux when brazing copper refrigerant pipes. Use copper-phosphorus alloys (BCuP) where no flux is required.
- Flux is harmful to the cooling pipe system. For example, if a chlorine-based flux is used, pipes will be corroded. Especially when the flux contains fluorine, the flux will degrade the frozen oil.

## Connecting wires

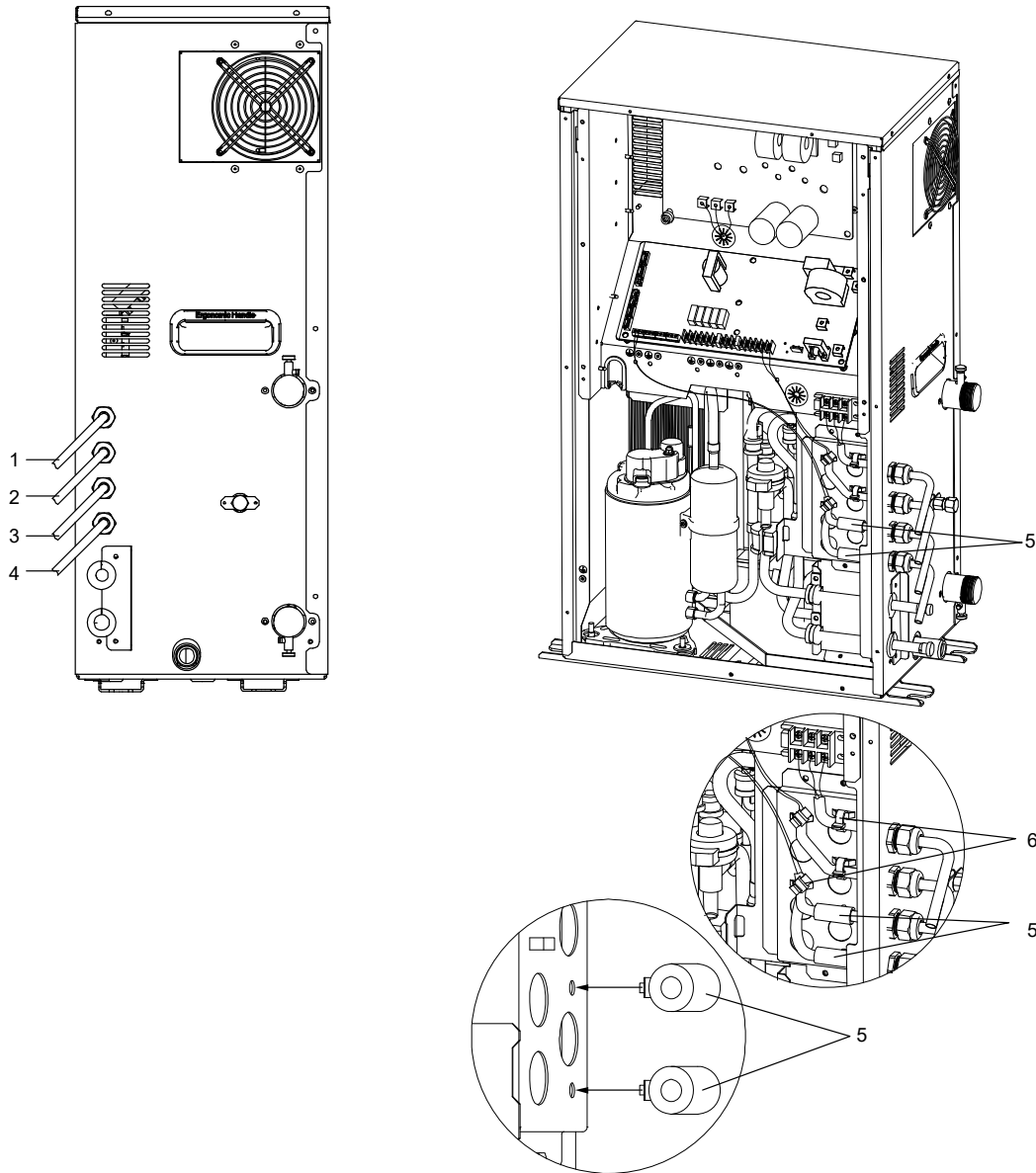

1	Power input
2	High Voltage Signal
3	Low Voltage Signal
4	Communication Cables
5	Magnetic Ring
6	Cable Tie

- When the external wire enters the interior of the unit through a waterproof cable connector, you need to separate the strong-current cable from the weak-current cable for cabling. For details, see the diagram.
- Inside the unit, wires should be fixed by using a cable tie through the overpass-shape component.
- Both the signal cable and output cable must be fitted with a magnetic ring, and then fixed on the overpass-shaped component by using a cable tie.

- Connection for other components

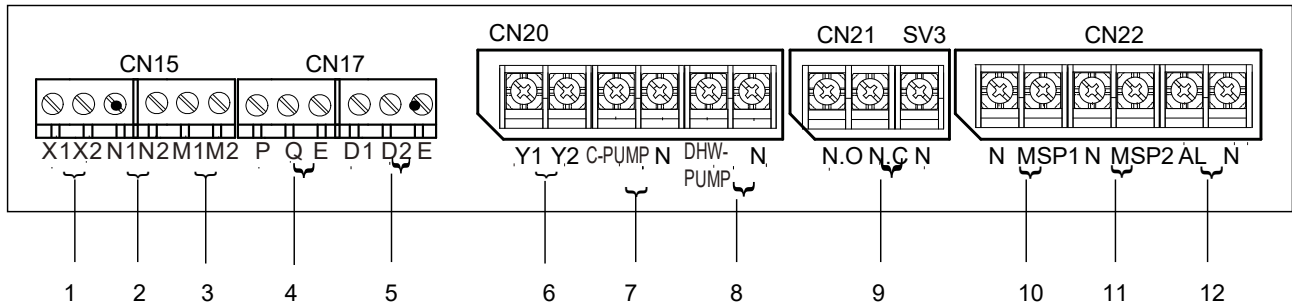

Coding	Assembly unit	Coding	Assembly unit
1	Connecting the wired controller	7	Connecting the circulating water pump AC contactor
2	Free electrical signal	8	Connecting the AC contactor for controlling water tanks and water pumps
3	Cheap electrical signal	9	Connecting the three-way valve
4	Outdoor/MS units communication .bus	10	Energy demand adjustment 1 input
5	Hydraulic module group control interface/connecting to the KNX gateway	11	Energy demand adjustment 2 input
6	Reserved	12	Alarm output -230 V~

- Wired controller wiring

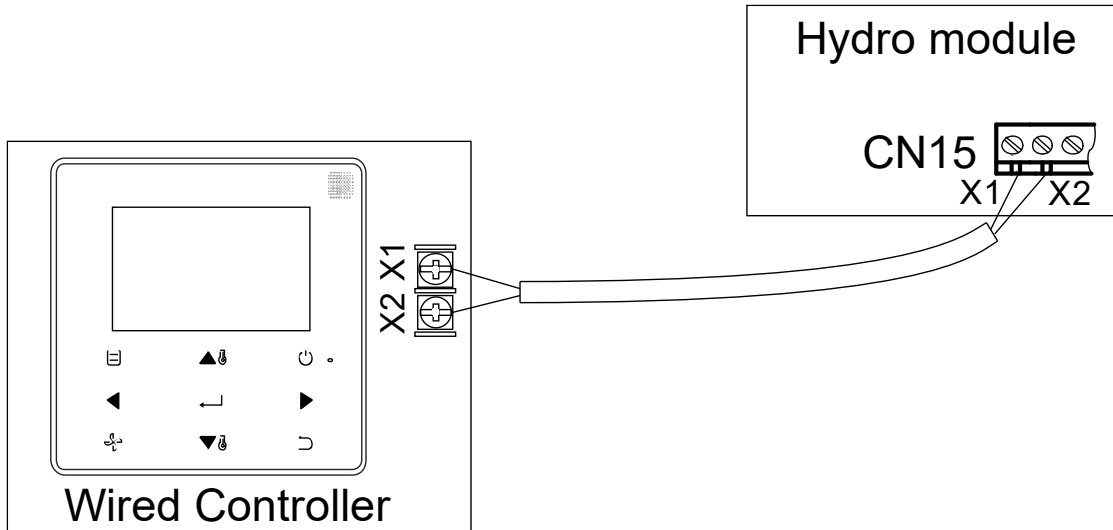

- Wires X1 and X2 do not have polarity requirements.

Voltage	18 V DC
Maximum running current (A)	0.1
Wiring size (mm <sup>2</sup> )	2x0.5

- Free electrical signal port N1/N2
- Cheap electrical signal port M1/M2

Used for energy management and to identify cheap or free electricity. When N1 is connected to N2, the electricity is determined to be free electricity. When M1 is connected to M2, the electricity is determined to be cheap electricity. When receiving cheap or free electrical signal, the hydraulic module will automatically start. (For detailed settings, refer to the Service Manual)

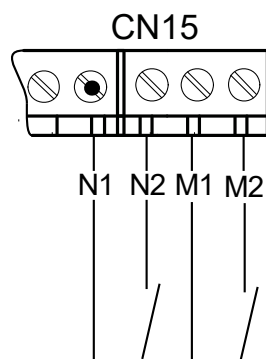

Voltage	12 V DC
Maximum running current (A)	< 0.1
Wiring size (mm <sup>2</sup> )	2x0.5

- Connection line group for IDU and ODU / MS communication

Used to connect IDU and ODU communication and transfer the control signals of the IDU and ODU. Please use the wire with a shield layer and ensure that the shield layer is grounded. For instructions on how to connect the ODU or MS, please see the corresponding manual.

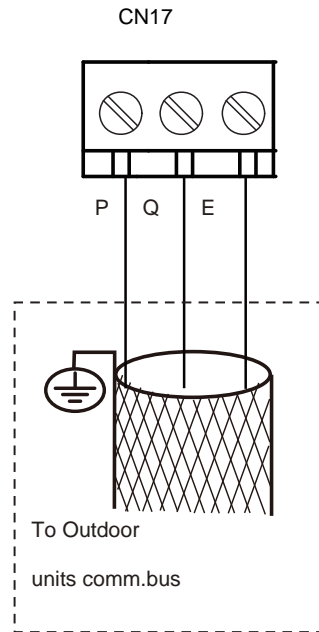

Voltage	5 V DC
Maximum running current (A)	< 0.1
Wiring size (mm <sup>2</sup> )	3x0.75 shielded cable

- Group control connection method/KNX gateway connection method
- The hydraulic module can provide the function of group control so that one module can control multiple units. In the entire system, only one master wired controller can be deployed to control units. Each unit can connect one slave wired controller for data query.
- Up to 10 units can be controlled.

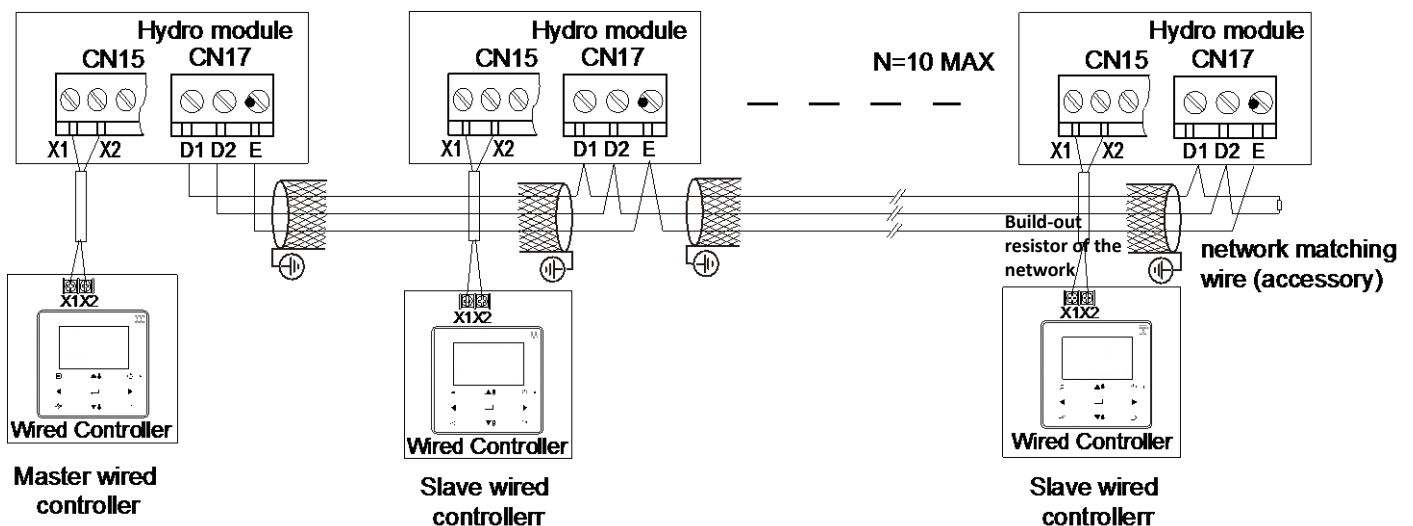



- The hydraulic module can connect the KNX gateway via D1\D2\E so that the third-party wired controller can control the hydraulic module. In this case, X1 and X2 can be used for check query by connecting or without connecting the wired controller, but cannot be used for control.

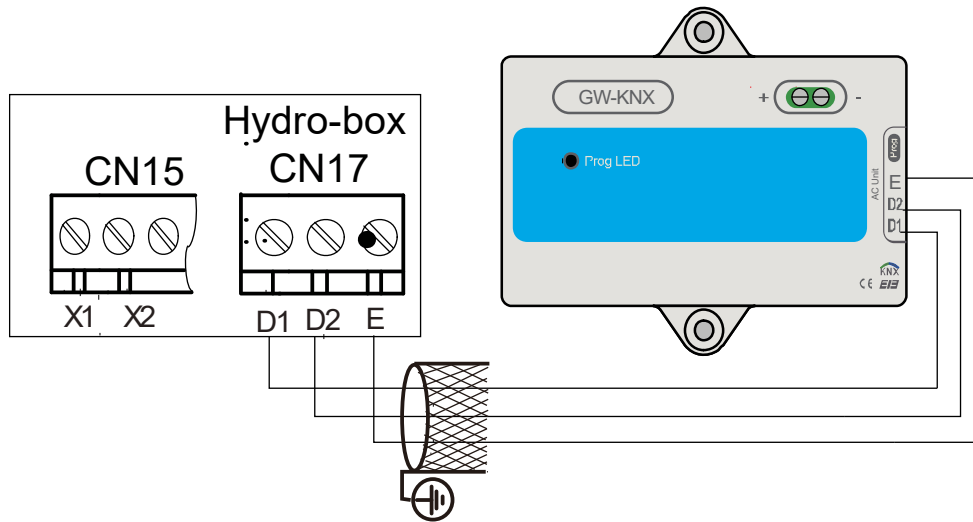

Voltage	5 V DC
Maximum running current (A)	< 0.1
Wiring size (mm <sup>2</sup> )	3x0.75 shielded cable

## HWM-2 High Temperature Hydro Module

- Reserving Y1/Y2 at port
- Output control interface of the circulating water pump
- Output control interface of the water tank and water pump

Note: The circulating water pump, water tank and water pump are connected to an external contactor for control. Do not directly connect the water pump.

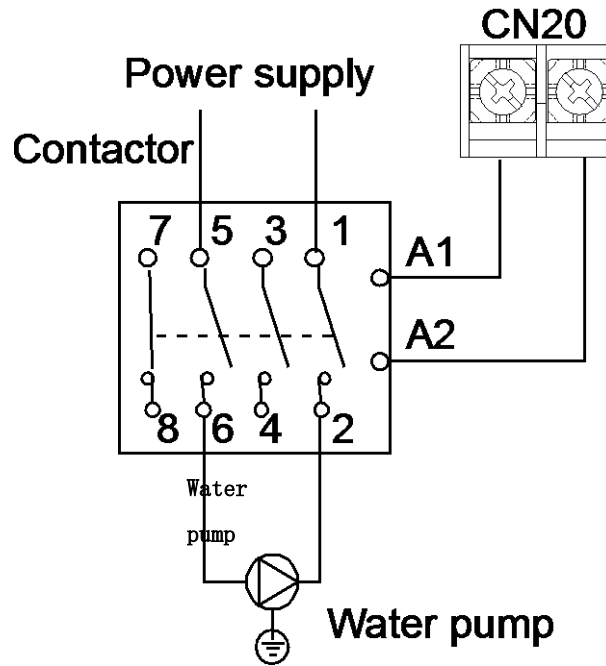

Voltage	220-240V
Maximum running current (A)	2
Wiring size (mm <sup>2</sup> )	2x0.75

• **Controlling ports via a three-way valve**

The three-way valve offers the following two methods, subject to the models sold in the market. For details, see the three-way valve manual. N.O indicates normally open output, while N.C indicates normally closed output.

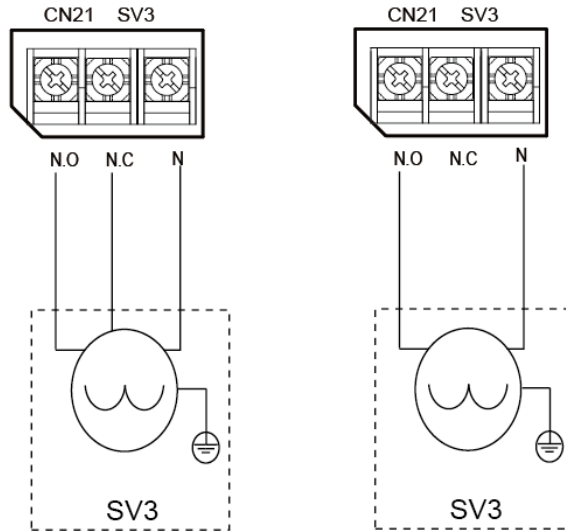

Voltage	220-240V~
Maximum running current (A)	1
Wiring size (mm <sup>2</sup> )	3x0.75

• **Three-way valve installation**

Check the three-way valve type. Connect it to the electric control board. For instructions on how to connect ports and wires.

Note: Before installing the three-way valve, check the port opening direction.

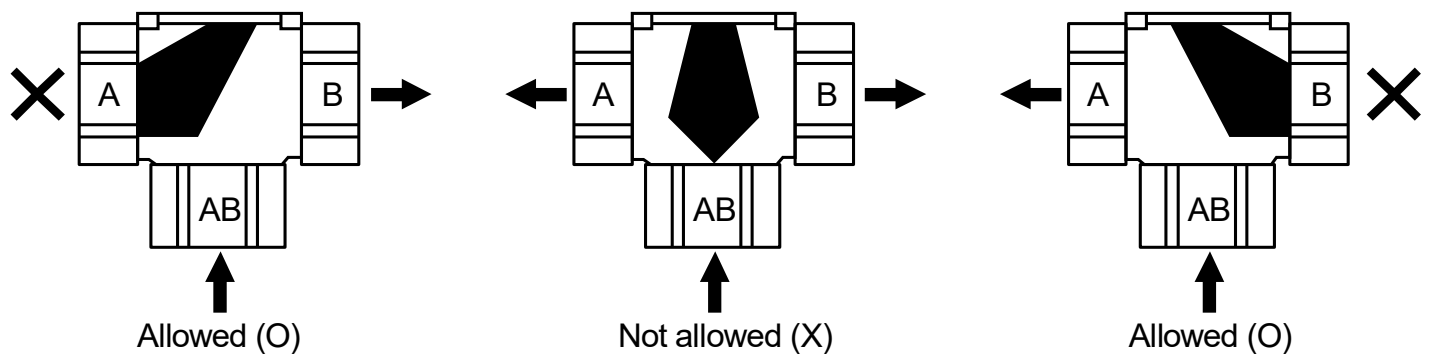

- Input port 1 of temperature multiple set point
- Input port 1 of temperature multiple set point

# HWM-2 High Temperature Hydro Module

To set the temperature at multiple points, connect a third-party thermostat to set different temperature set points.

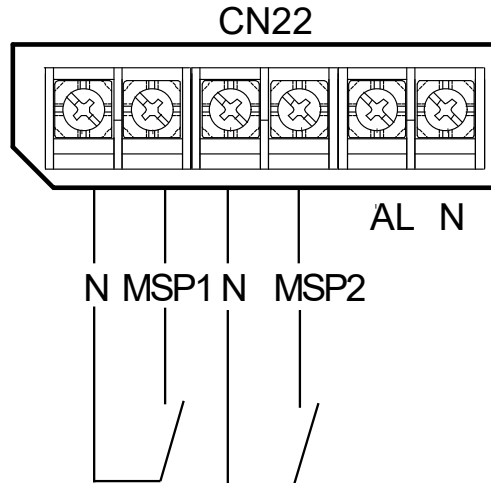

Voltage	220-240V~
Maximum running current (A)	< 0.1
Wiring size (mm <sup>2</sup> )	2x0.75

- **Alarm output signal**

When the unit fails, a signal can be output to indicate the unit status.

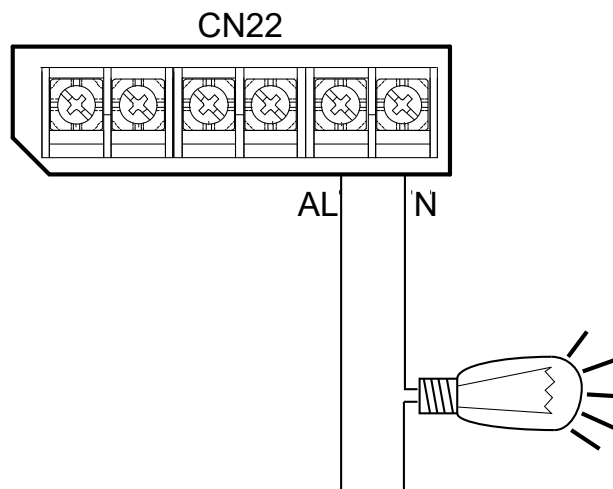

Voltage	220-240V~
Maximum running current (A)	1
Wiring size (mm <sup>2</sup> )	2x0.75

Note: After wires are connected, do not place the redundant wires into the unit.

- **Installing the wired controller**

This unit is equipped with a wired controller, which is used to set, operate, and maintain this unit. Before operating the wired controller, please follow the installation procedures.

### Notes for installers and service engineers

#### Caution

- The connecting wire is excluded tank temperature. The hydraulic module controls the three-way valve to switch to heating or DHW modes.
- The wired controller is delivered as a kit and must be installed indoors.
- When the temperature control function of the wired controller is used, please select an installation site that satisfies the following conditions:
  - The average temperature of the room can be detected.
  - The installation site is free from direct sunshine.
  - The installation site is not near the heat source and the temperature is between 0 °C and 50 °C.
  - The installation site is not affected by outdoor air or air pressure, for example, opening/closing of the door.
  - The display can be kept clean.

- **Wired controller dimensions**

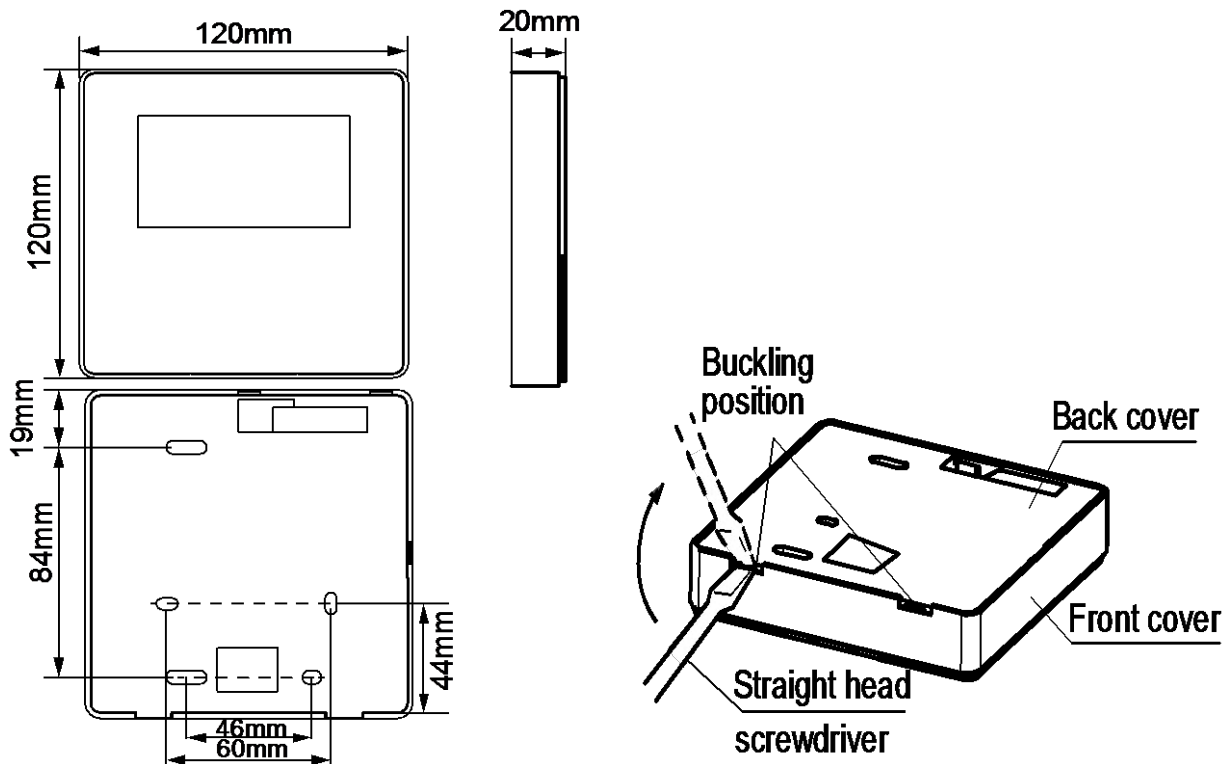

- ① Insert the tip of a straight head screwdriver into the bending location at the bottom of the wired controller. Raise the screwdriver to pry open the rear cover. Pay attention to the direction when prying open the rear cover. Prying in an incorrect direction will damage the rear cover.

- ② Fix the rear cover on the wall.

Note: Do not excessively tighten the installation screws to prevent rear cover deformation of the wired controller.

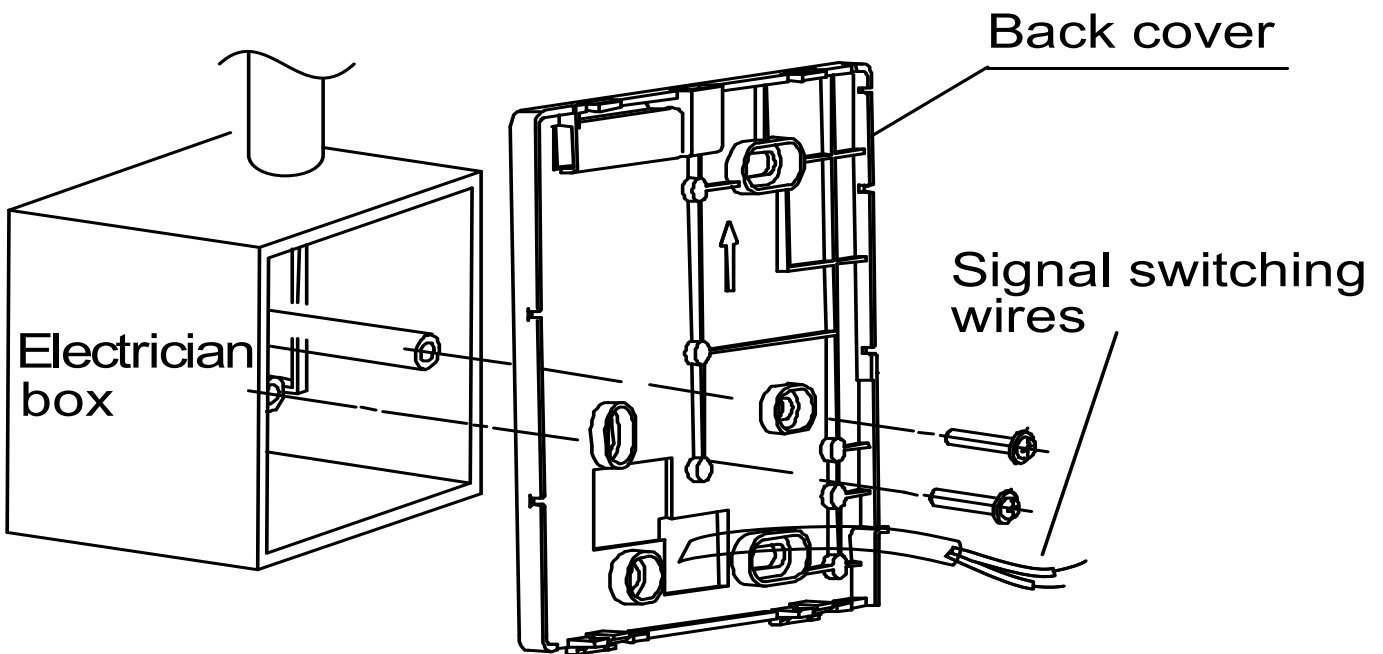
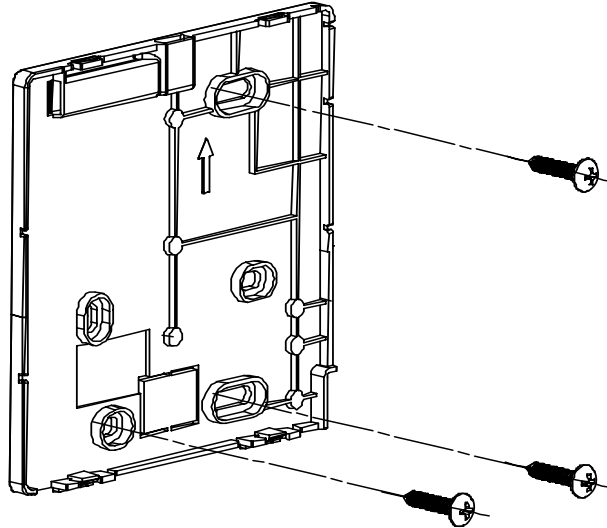

③ Wire the wired controller.

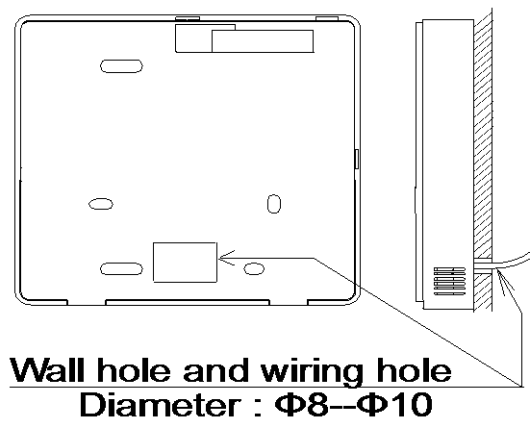
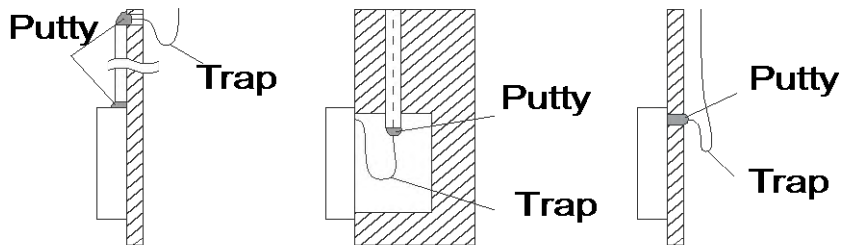
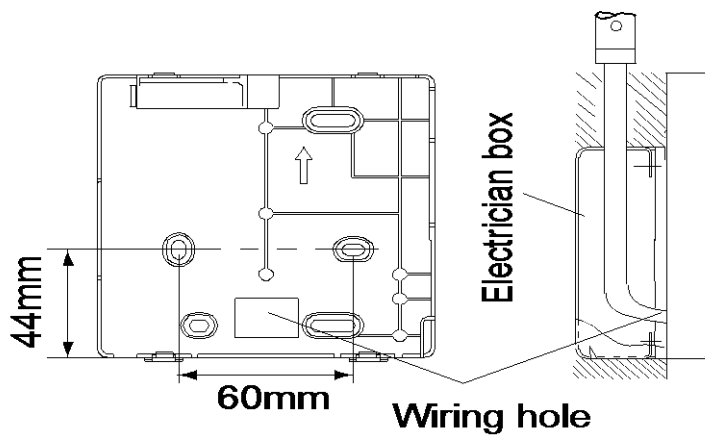
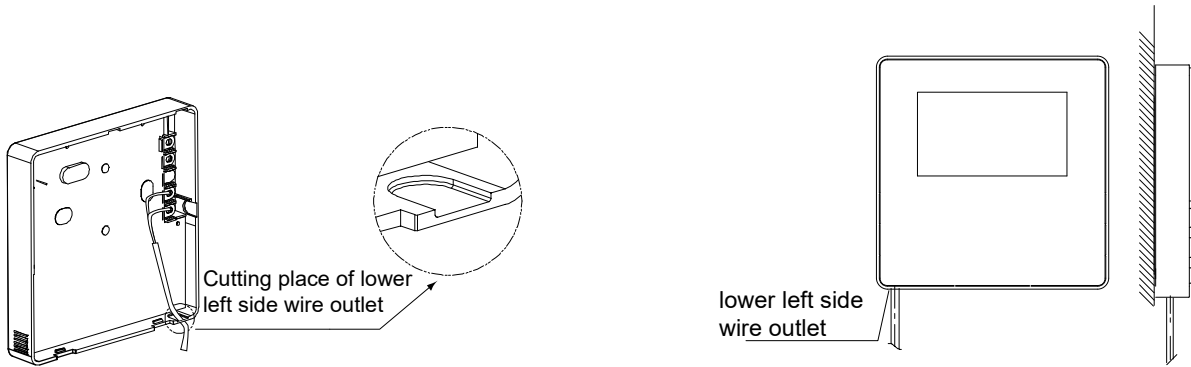

④ Connect the wired controller to the unit.

Note: \* Do not jam wires during installation.

## 8 Application Examples

Only heating mode and water outlet temperature control mode.

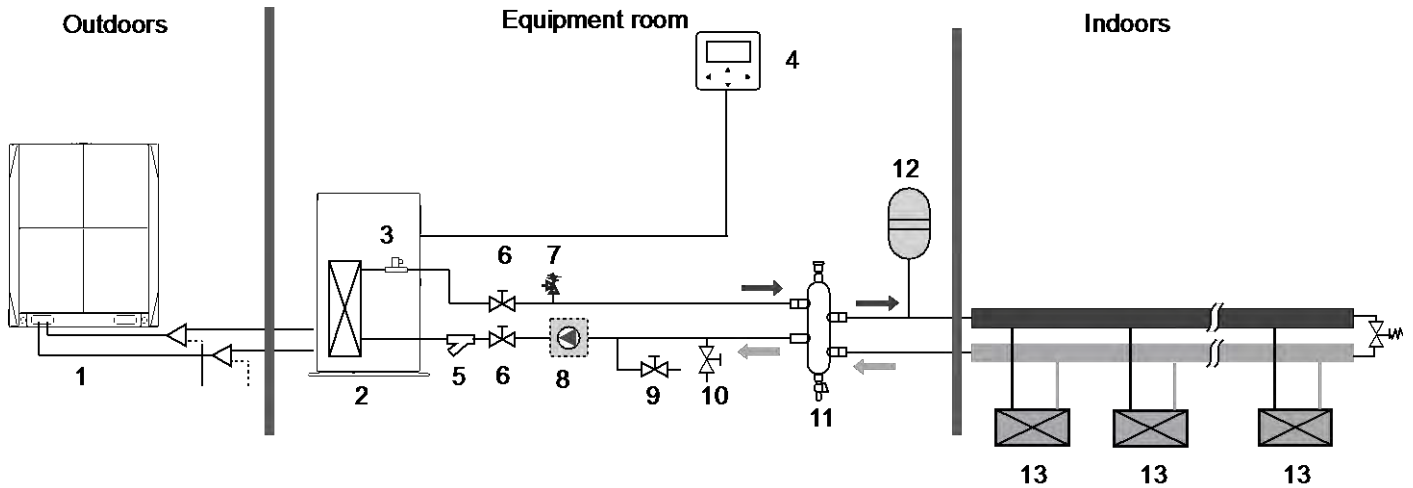

1	ODU
2	Hydraulic module
3	Water flow switch
4	Wired controller (Accessory)
5	Y-shaped filter (Accessory)
6	Check valve (Provided on site)
7	Safety valve (Accessory)
8	Water pump (Provided on site. For model selection, see page 32.)
9	Drain valve (Provided on site)
10	Water replenishing valve (Provided on site)
11	Water collector (Provided on site)
12	Water expansion tank (Provided on site. For model selection, see page 33.)
13	Terminals. The unit can connect to the floor heating device FHL (25 °C-45 °C), fan coil FCU (45 °C-60 °C), and radiator (60 °C-80 °C), which have different temperature requirements.



On-site settings of the wired controller:

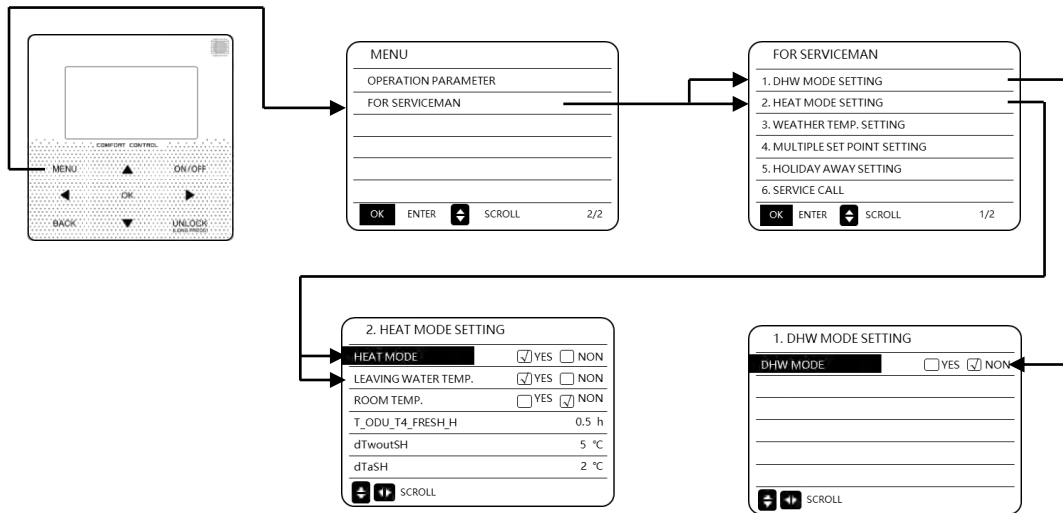

HEAT MODE=YES  
Heat mode is valid.  
LEAVING WATER  
TEMP.=YES  
Water outlet temperature  
control is valid.

DHW MODE=NON  
DHW mode is  
invalid.

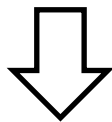

Temperature  
settings

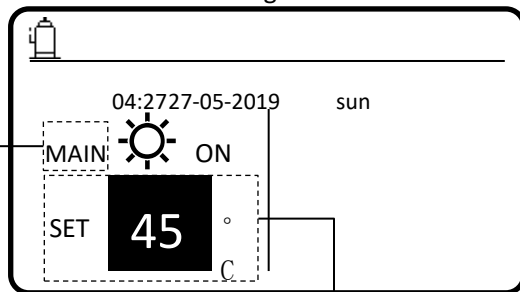

MAIN indicates water  
outlet temperature  
control.

Sets the desired water  
outlet temperature,  
ranging from 25 C to 80 C.

# HWM-2 High Temperature Hydro Module

Only heating mode and room temperature control mode.

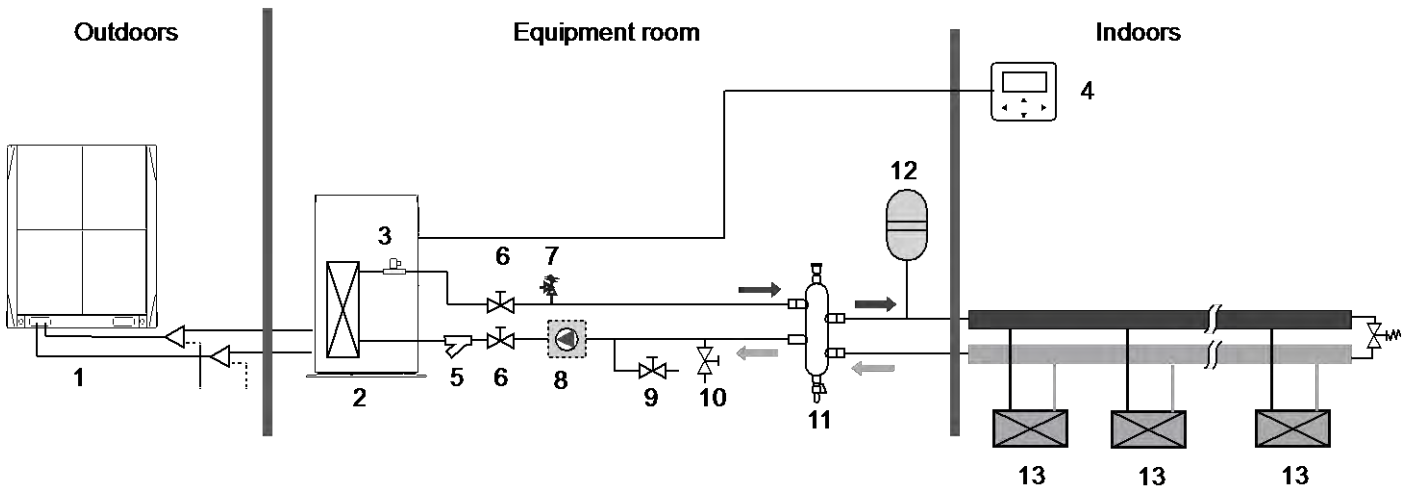

1	ODU
2	Hydraulic module
3	Water flow switch
4	Wired controller (Accessory)
5	Y-shaped filter (Accessory)
6	Check valve (Provided on site)
7	Safety valve (Accessory)
8	Water pump (Provided on site. For model selection, see page 32.)
9	Drain valve (Provided on site)
10	Water replenishing valve (Provided on site)
11	Water collector (Provided on site)
12	Water expansion tank (Provided on site. For model selection, see page 33.)
13	Terminals. The unit can connect to the floor heating device FHL (25 °C-45 °C), fan coil FCU (45 °C-60 °C), and radiator (60 °C -80 °C), which have different temperature requirements.

Note: \*The wired controller is placed indoors. Room temperature is detected by the embedded temperature sensor.

On-site settings of the wired controller:

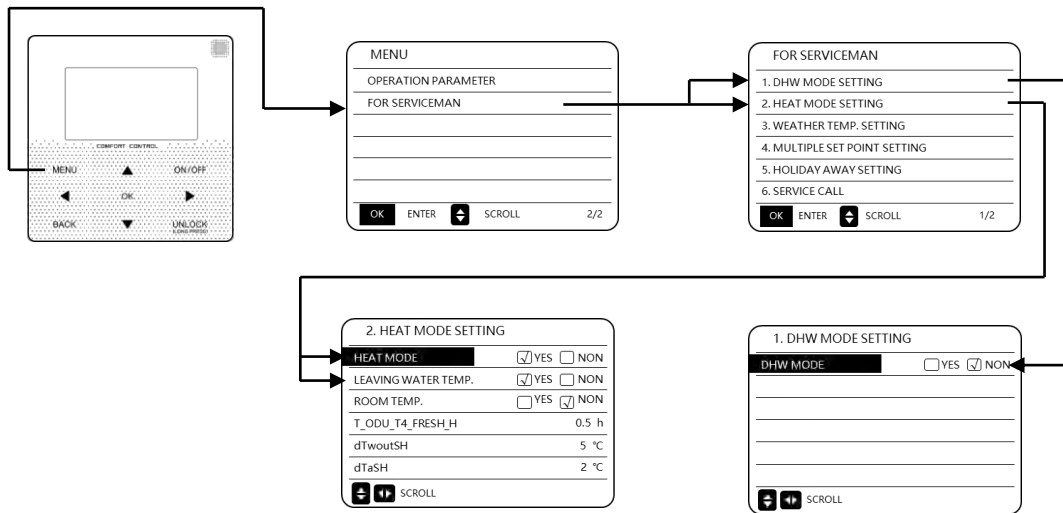

**HEAT MODE=YES**  
Heat mode is valid.  
**LEAVING WATER TEMP.=YES**  
Water outlet temperature control is valid.

**DHW MODE=NON**  
DHW mode is invalid.

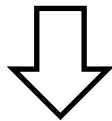

**Temperature settings**

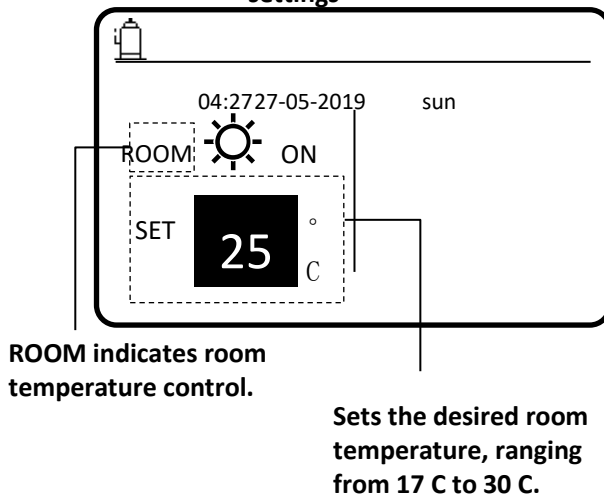

# HWM-2 High Temperature Hydro Module

Only DHW mode.

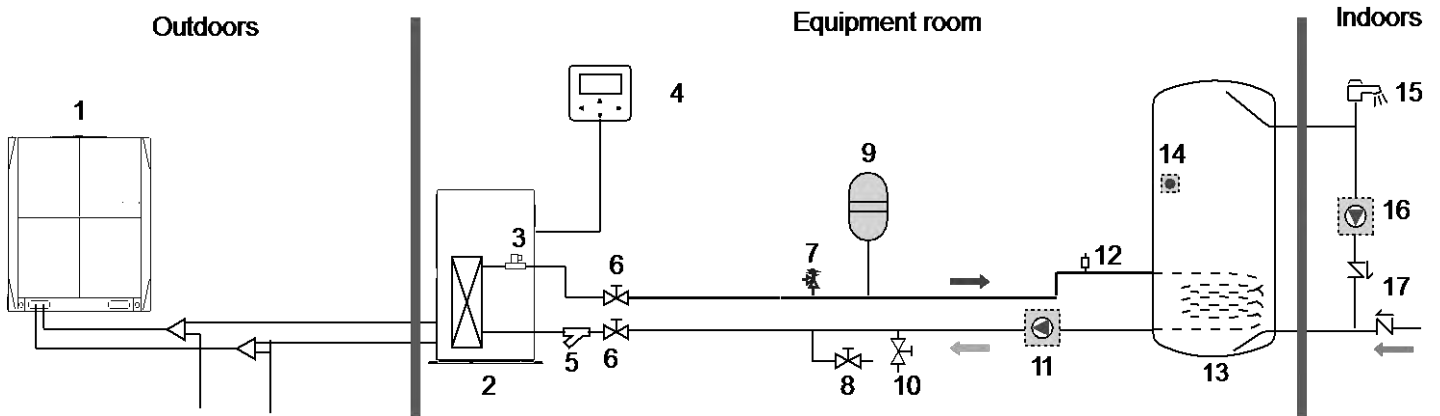

1	ODU
2	Hydraulic module
3	Water flow switch
4	Wired controller (Accessory)
5	Y-shaped filter (Accessory)
6	Check valve (Provided on site)
7	Safety valve (Accessory)
8	Drain valve (Provided on site)
9	Water expansion tank (Provided on site. For model selection, see page 32.)
10	Water replenishing valve (Provided on site)
11	Water pump (Provided on site. For model selection, see page 33.)
12	Discharge valve (Provided on site)
13	Water tank (Provided on site)
14	Temperature sensor of the water tank (Accessory)
15	Tap (Provided on site)
16	Water tank and water pump (Provided on site)
17	One-way valve (Provided on site)

On-site settings of the wired controller:

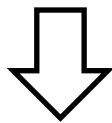
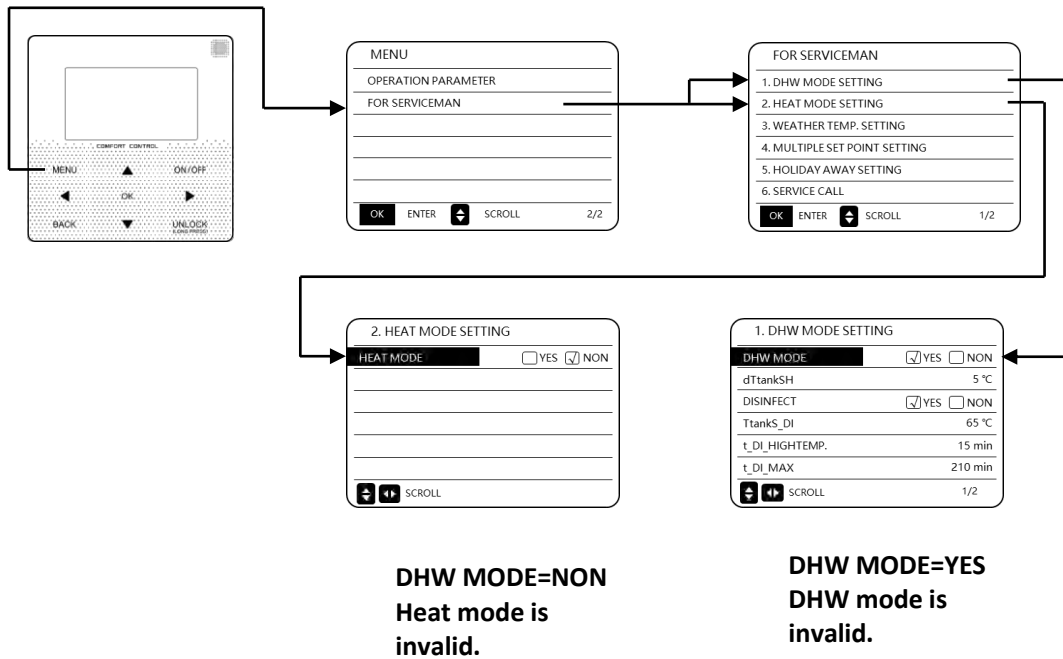

Temperature settings

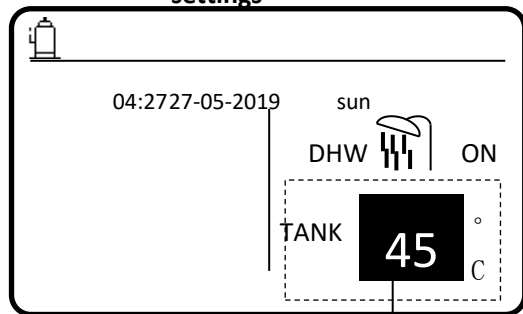

Sets the desired water tank temperature, ranging from 25 C to 80 C.

# HWM-2 High Temperature Hydro Module

Heat Mode and DHW Mode

Clivet HWM-2-XMi Technical Bulletin

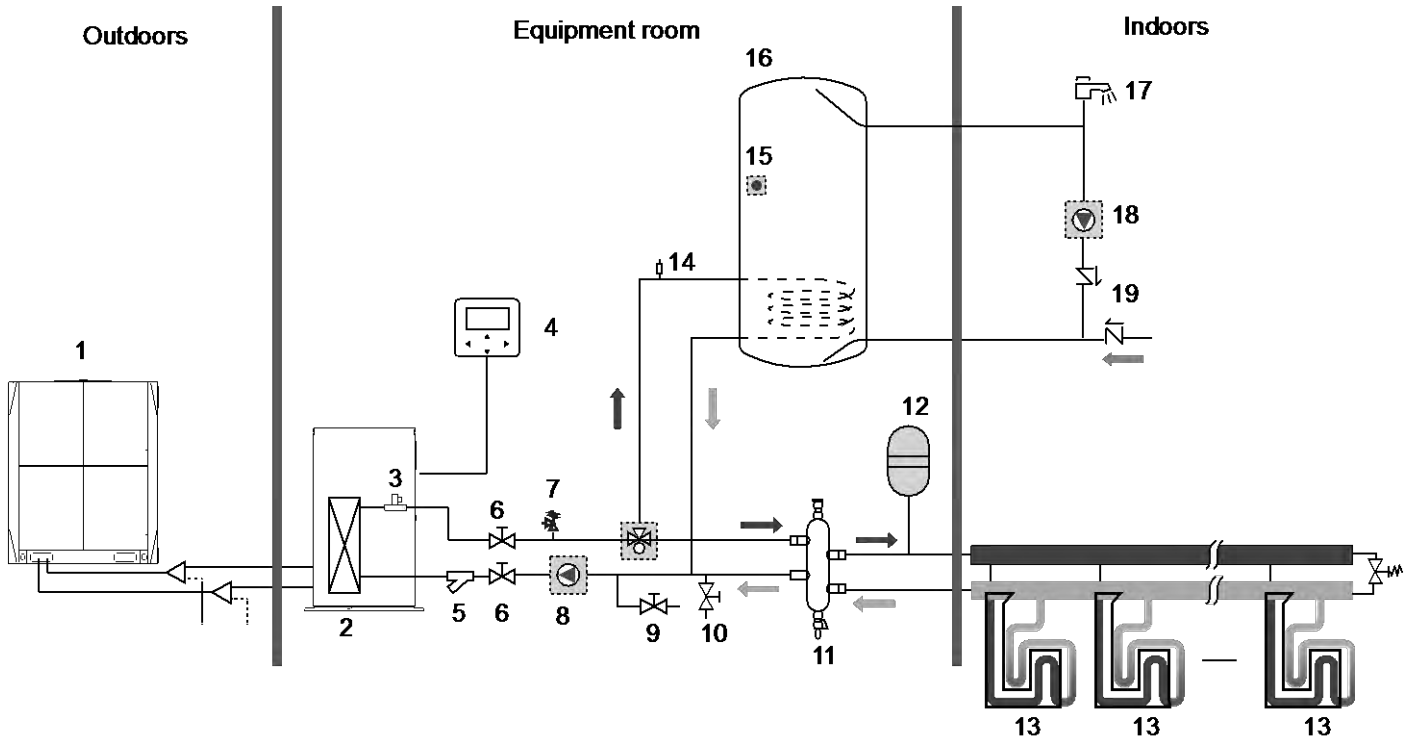

1	ODU
2	Hydraulic module
3	Water flow switch
4	Wired controller (Accessory)
5	Y-shaped filter (Accessory)
6	Check valve (Provided on site)
7	Safety valve (Accessory)
8	Water pump (Provided on site. For model selection, see page 32.)
9	Drain valve (Provided on site)
10	Water replenishing valve (Provided on site)
11	Water collector (Provided on site)
12	Water expansion tank (Provided on site. For model selection, see page 33.)
13	Terminals. The unit can connect to the floor heating device FHL (25 °C-45 °C), fan coil FCU (45 °C-60 °C), and radiator (60 °C-80 °C), which have different temperature requirements.
14	Discharge valve (Provided on site)
15	Water tank (Provided on site)
16	Temperature sensor of the water tank (Accessory)
17	Tap (Provided on site)
18	Water tank and water pump (Provided on site)
19	One-way valve (Provided on site)

## Notes for installers and service engineers

### Caution

Terminals on the water system side can connect the fan coil (floor heating device/radiator) for heating or a water tank for water heating. Water heating requires the temperature sensor of the water tank provided among accessories to detect

On-site settings of the wired controller:

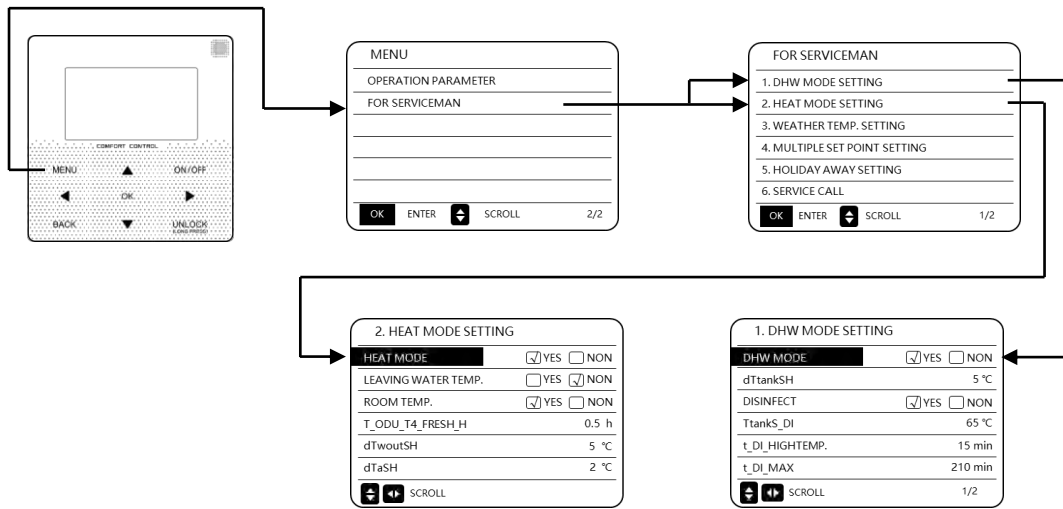

**DHW MODE=YES**  
Heat mode is  
invalid.

**DHW MODE=YES**  
DHW mode is  
invalid.

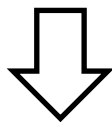

Temperature  
settings

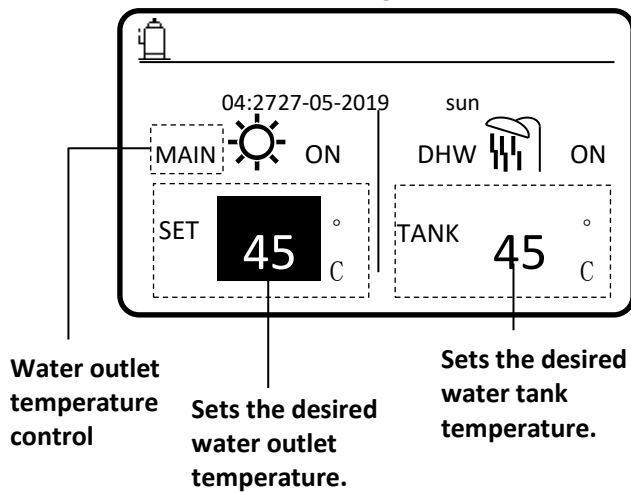

# HWM-2 High Temperature Hydro Module

Only heating mode and multiple set points for heating mode.

## Notes for installers and service engineers

### Caution

When one hydraulic module is connected to multiple terminals that have different temperature requirements (such as the floor heating device, fan coil unit, and radiator), you need to use the multiple set point function.

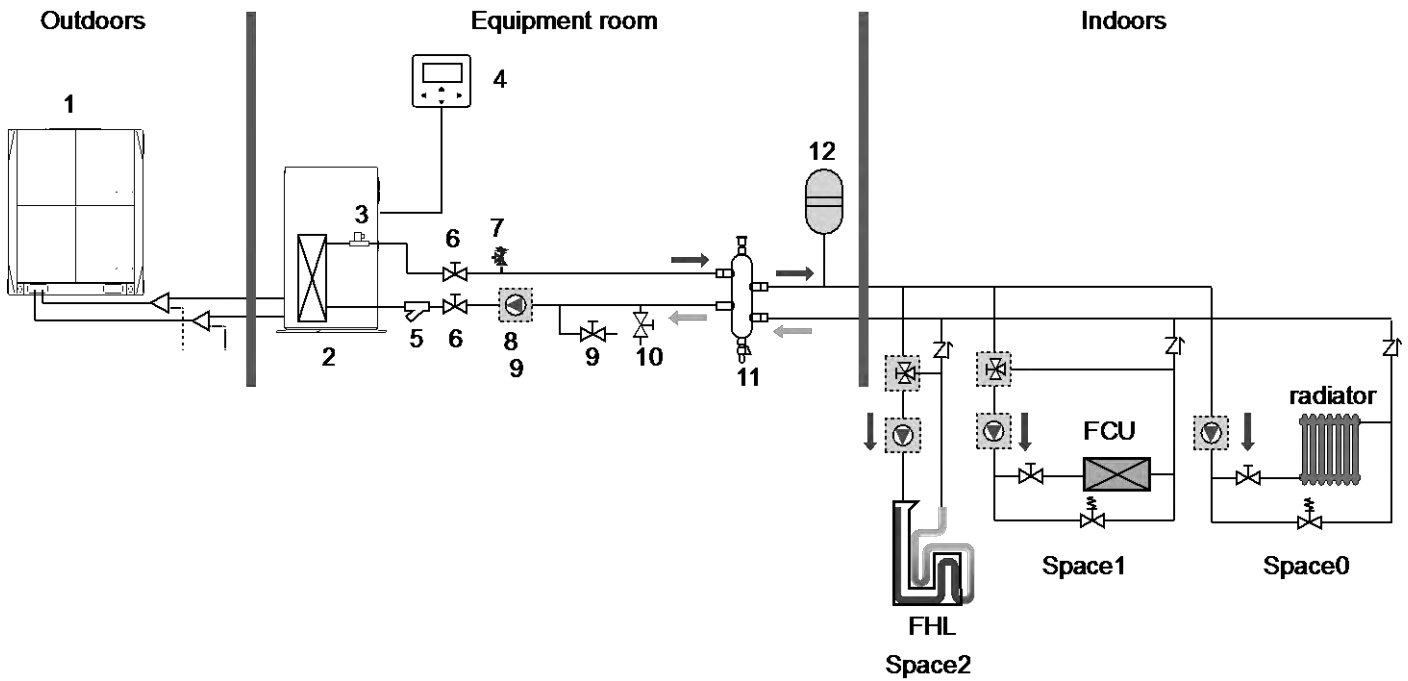

1	ODU
2	Hydraulic module
3	Water flow switch
4	Wired controller (Accessory)
5	Y-shaped filter (Accessory)
6	Check valve (Provided on site)
7	Safety valve (Accessory)
8	Water pump (Provided on site. For model selection, see page 32.)
9	Drain valve (Provided on site)
10	Water replenishing valve (Provided on site)
11	Water collector (Provided on site)
12	Water expansion tank (Provided on site. For model selection, see page 33.)



**Enabling the multiple set point of the wired controller:**

- When only heating mode is available, the settings are the same as those described above.
- Multiple set point settings are as follows:

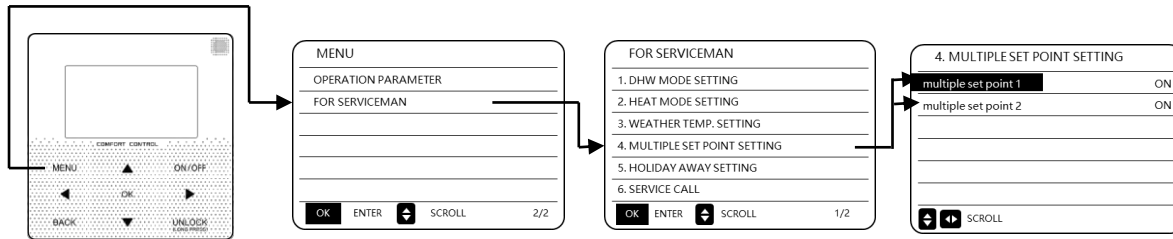

**multiple setpoint1=ON: Enable multiple set point 1;  
multiple setpoint2=ON: Enable multiple set point 2;**

- Temperature settings of multiple set points

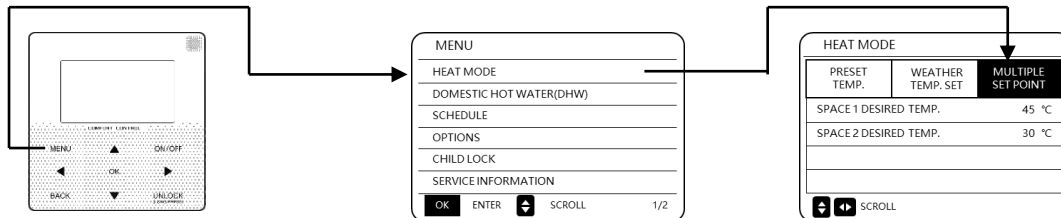

**SPACE 1 DESIRED TEMP.: Desired temperature of multiple set point 1;  
SPACE 2 DESIRED TEMP.: Desired temperature of multiple set point 2;**

No.	Desired temp.	Thermo status			
space 0	a	OFF	ON	OFF	OFF
space 1	b	OFF	ON/OFF	ON	OFF
space 2	c	OFF	ON/OFF	ON/OFF	ON
Resulting desired temp.		OFF	a	b	c

**Notes for installers and service engineers**

**Caution**

- space0 can be set on the main interface of the wired controller, while space1 and space2 temperature are set on the HEAT MODE interface
- space0 should be the terminal that requires the highest temperature, while space2 requires the lowest temperature. The temperature required by space1 is between those of space0 and space2. Both space1 and space2 require a temperature reduction device.
- The hydraulic module controls the water outlet temperature according to the highest required temperature in the event of energy demand availability

# HWM-2 High Temperature Hydro Module

Multiple hydro modules connected to the same outdoor unit in group control

## Notes for installers and service engineers

### Caution

When multiple hydraulic modules heat water for one water tank, the group control function of the hydraulic module should be used.

The group control function is only valid to the DHW mode.

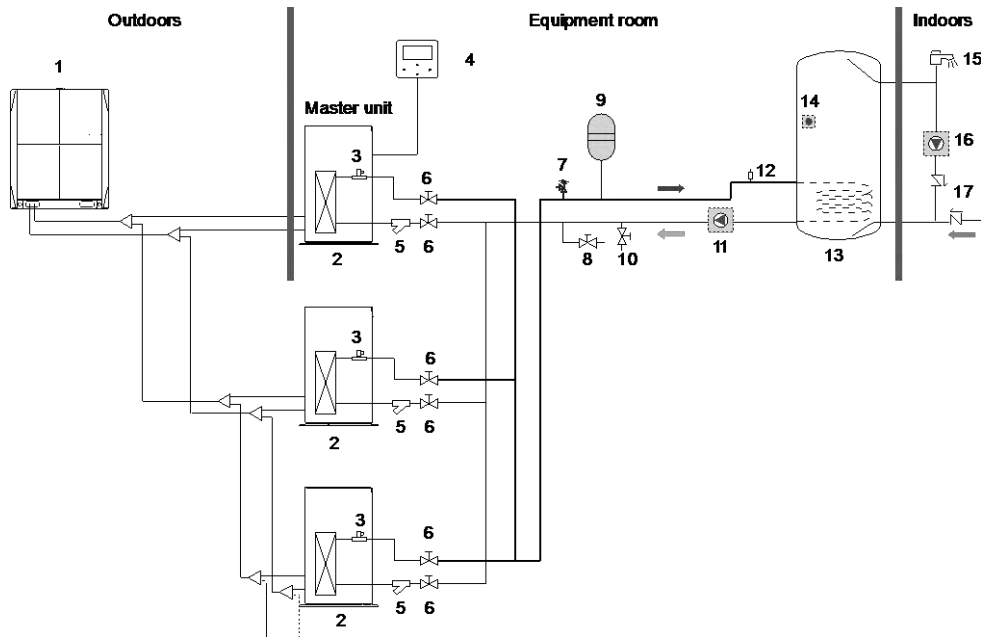

1	ODU
2	Hydraulic module
3	Water flow switch
4	Wired controller (Accessory)
5	Y-shaped filter (Accessory)
6	Check valve (Provided on site)
7	Safety valve (Accessory)
8	Drain valve (Provided on site)
9	Water expansion tank (Provided on site. For model selection, see page 32.)
10	Water replenishing valve (Provided on site)
11	Water pump (Provided on site. For model selection, see page 33.)
12	Discharge valve (Provided on site)
13	Water tank (Provided on site)
14	Temperature sensor of the water tank (Accessory)
15	Tap (Provided on site)
16	Water tank and water pump (Provided on site)
17	One-way valve (Provided on site)

To enable the group control function, you need to use the following steps to set the DIP switch on the main board: for the master hydraulic module, turn digit 11; for the slave hydraulic module, turn digit 10.

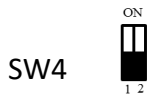

Group control function setting:

00 and 01: Group control function is unavailable.

11: Group control function is available. This hydraulic module is a master hydraulic module.

10: Group control function is available. This hydraulic module is a slave hydraulic module.

### Notes for installers and service engineers

#### Caution

- By default, the value is 00, indicating that a controlled group contains only one master unit.
- The master unit must be connected to a wired controller. The wired controller is used to set the desired water tank temperature.
- The slave unit can be connected to or is not connected to a wired controller. The wired controller of the slave unit provides the query function only.
- The pump is controlled by the master unit. The temperature sensor of the water tank is connected to the master unit.
- The wired controller is connected to the master unit is used to set the desired water tank temperature.

## Temperature settings for the wired controller of the master unit:

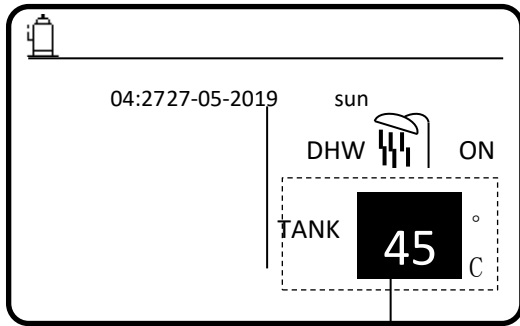

Sets the desired water tank temperature, ranging from 25 C to 80 C.

### Notes for installers and service engineers

#### Caution

- When the water system side of multiple hydraulic modules are connected in parallel and heat water for a single water tank, you need to set master and slave hydraulic modules. The temperature sensor of the water tank is connected to the master hydraulic module and the master hydraulic module sends the water tank temperature to the slave hydraulic module.
- Only the wired controller connected to the master unit can be used to set the desired water tank temperature. The master unit is used to control the switch of the circulating water pump.
- In all the preceding installation scenarios, it is recommended that the automatic air discharge valve should be installed at the highest point of the water system.

### 9 Pump Model Selection

- The water pump should meet the flow requirements of the hydraulic module. The rated flow of the hydraulic module is 2.4 m<sup>3</sup>/h, while the allowed flow range is [1.2, 2.9] m<sup>3</sup>/h.
- The water pump model is based on the calculation of the water resistance and pipe resistance of the hydraulic module. The hydraulic module fluid pressure is as shown in the following figure.

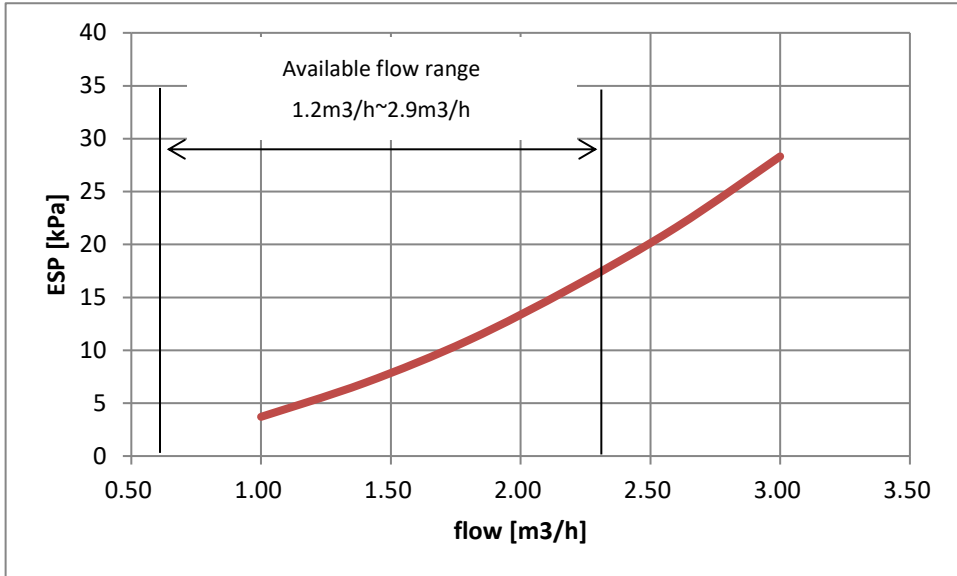

For example:

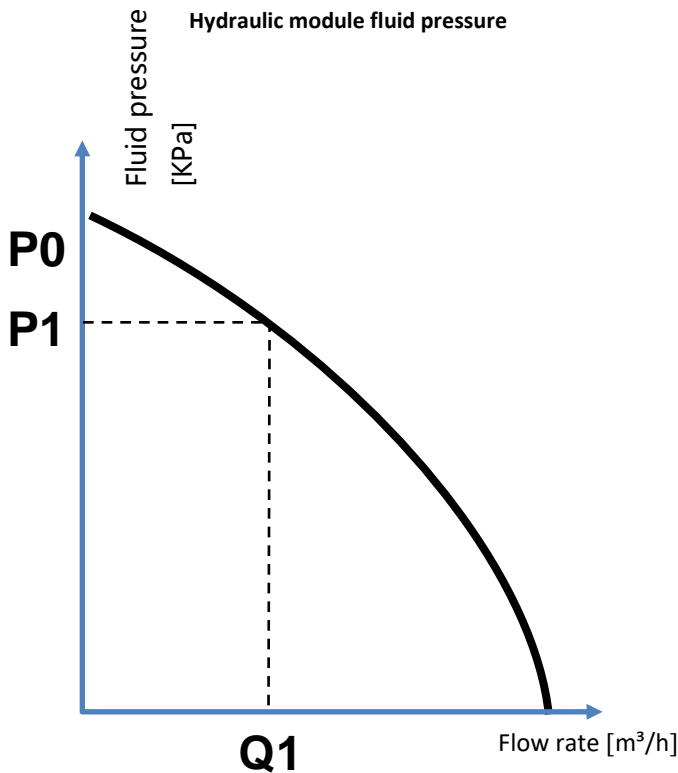

Assume that the performance curve of the selected water pump is as shown in the black figure. When total water resistance in the water system is P1, the flow rate is Q1. When Q1 is within the allowed range of the hydraulic module, the water pump is suitable. When Q1 is greater than 2.9 m<sup>3</sup>/h, water pump capacity can be decreased. When Q2 is less than 1.2 m<sup>3</sup>/h, the water pump capacity should be increased.

## 10 Selection of Expansion Tank Volume and Preset Pressure

- Calculating the preset pressure of the expansion tank

$$Pg = \frac{H}{10} + 0.3 \text{ bar}$$

**H—The highest point of the water system is higher than the hydraulic module.**

If  $Pg$  is less than the initially preset pressure of the expansion tank, you do not need to adjust the preset pressure of the expansion tank. In general, the initially preset pressure of the expansion tank is 1.5 bar.

- Calculating the minimum volume of the expansion tank

$$V = 0.0693 * V_{\text{water}} / (2.5 - Pg)$$

**$V_{\text{water}}$ —Total water volume of the water system**

Example 1: Total water volume of the water system of a project is 200 L. The highest point of the water system is 12 m higher than the hydraulic module. Calculate the preset pressure and volume of the expansion tank.

Answer: The preset pressure of the expansion tank is  $12 / 10 + 0.3 = 1.5$  bar. The required minimum volume of the expansion tank is  $V = 0.0693 * 200 / (2.5 - 1.5) = 13.86$  L.

Example 2: Total water volume of the water system of a project is 72 L. The highest point of the water system is 0 m higher than the hydraulic module. Calculate the preset pressure and volume of the expansion tank.

Answer: The preset pressure of the expansion tank  $Pg = 0 / 10 + 0.3 = 0.3$  bar, which is 1.5 bar less than the initially preset pressure of the expansion tank. The required minimum volume of the expansion tank is  $V = 0.0693 * 72 / (2.5 - 1.5) = 4.98$  L.

## 11 Domestic hot water tank

A domestic hot water tank (with or without booster heater) can be connected to the unit. The requirement of the tank is different for different unit and material of heat exchanger.

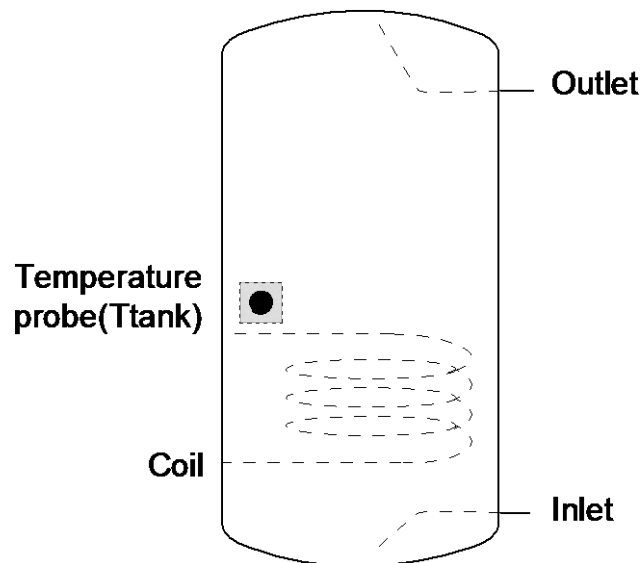

If the tank volume is greater than 240L, the temperature probe ( $T_{\text{Tank}}$ ) should be installed at a position higher than half of the tank's height.

If the tank volume is less than 240L, the temperature probe should be installed at a position higher than 2/3 of the tank's height.

If the booster is installed, the booster heater should be installed below the temperature probe.

The heat exchanger (coil) should be installed below the temperature probe.

The pipe length between the hydro module and tank should be less than 5 meters.

## 12 Final Check and Test Run

### 12.1 Final Check

Before closing the switch of the unit, please read the following information:

- When you complete installation of the unit and have performed all the necessary settings, ensure that all the metal plates are closed. This can protect you from electrical parts and high-temperature parts inside the unit.
- The electric control box cover plate can only be opened by an electrician who is certified for maintenance.
- Discharge air in the system.

### 12.2 Test Run

Test run is described on the installation manual of the ODU. This is an automatic test run, which will last for more than 1 hour.

## 13 Piping Design

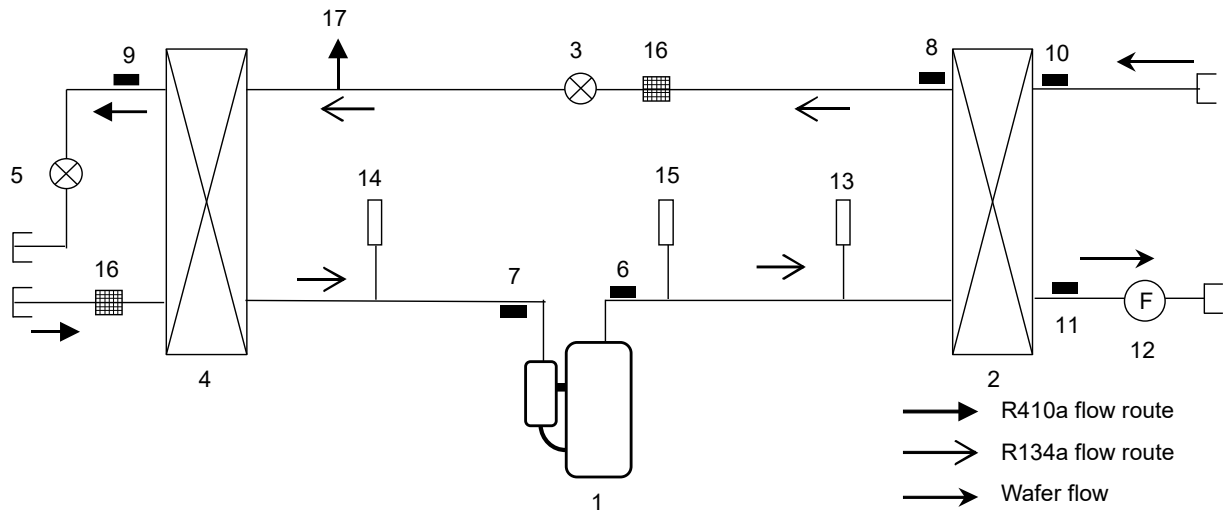

NO.	Description	
1	Compressor	/
2	R134a to water Plate heat exchanger	/
3	Electronic expansion valve 1	EEV1
4	R410a to R134a Plate heat exchanger	/
5	Electronic expansion valve 2	EEV2
6	Discharge pipe temperature sensor	T7C
7	Suction pipe temperature sensor	T7
8	R134a circle liquid pipe temperature sensor	T3
9	R410a circle liquid pipe temperature sensor	T2A
10	Water inlet temperature sensor	Twin
11	Water outlet temperature sensor	Twout
12	Flow switch	FS
13	High pressure sensor	H-YL
14	Low pressure sensor	L-YL
15	High pressure switch	H-Pro
16	strainer	/
17	Service pot	/

### Key components:

1. Compressor: Drive R134a coolant flow
2. R134a to water Plate heat exchanger :
3. Electronic expansion valve 1: Control R134a refrigerant circulation flow
4. R410a to R134a Plate heat exchanger : Heat transfer between R410a and R134a refrigerants
5. Electronic expansion valve 2: Control the R410a coolant flow of the hydraulic module



14 Wiring Diagram

Figure 9.1: Power and communication wiring

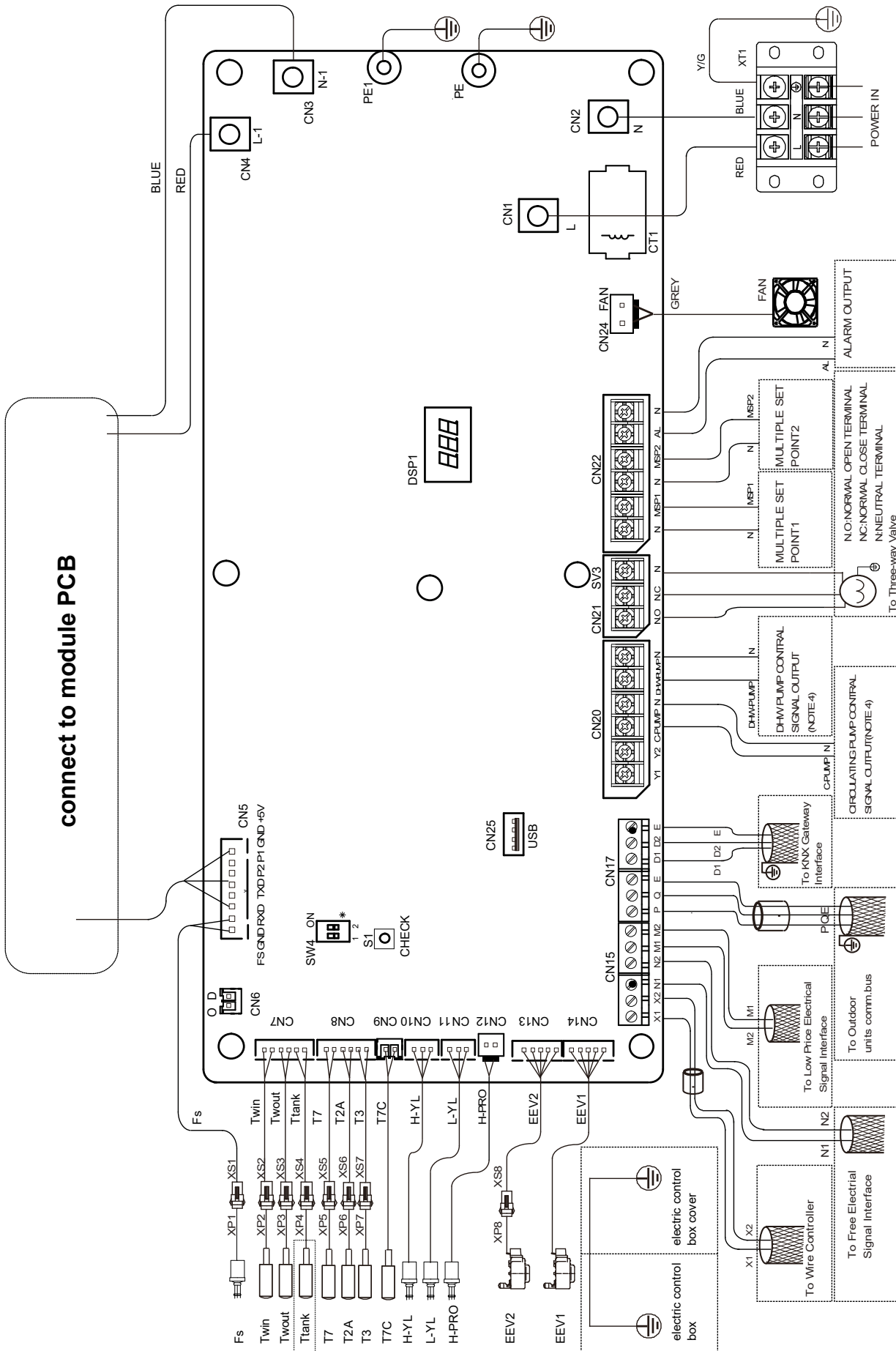

## 15 Sound Levels

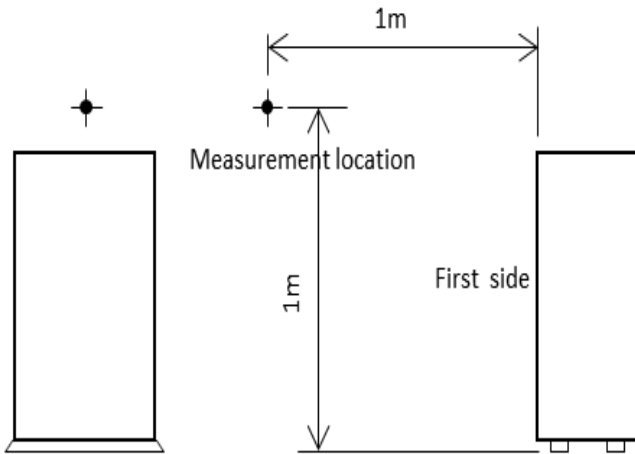







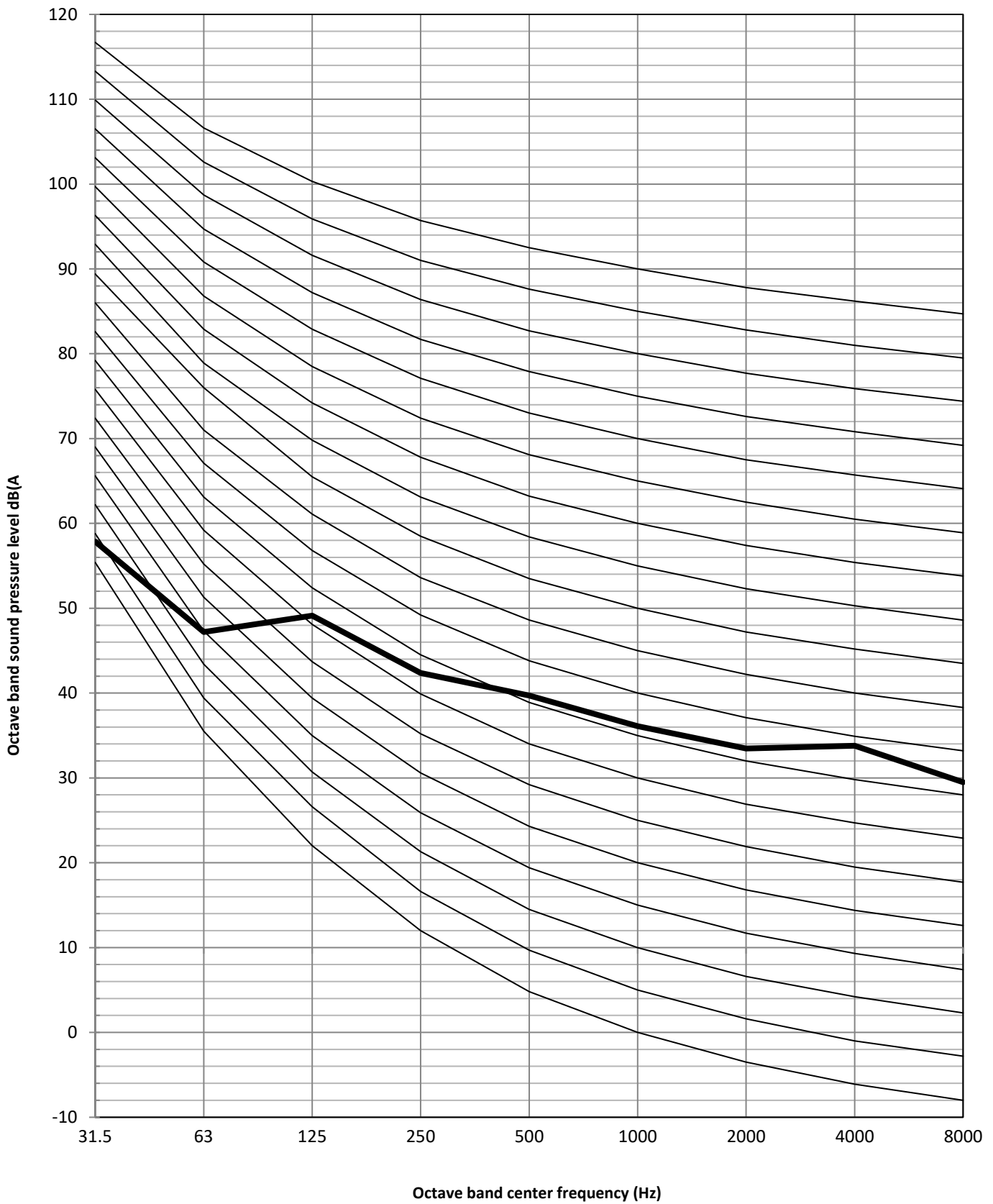

**Notes:**

- Sound measured at 1.0m away from the center of the unit.
- Data is valid at free field condition
- Data is valid at nominal operating condition
- Sound level will vary depending on a range of factors such as the construction (acoustic absorption coefficient) of particular room in which the equipment is installed.
- Condition: rated heating condition  
 Inlet water Temp. : 40°C  
 Outlet water Temp. : 45°C  
 Water flow rate : 2.4 m<sup>3</sup>/h  
 Outdoor Temp. : 7 °C/6°C (DB/WB)

Sound pressure level	<b>Nom.</b>	<b>dB (A)</b>	<b>43</b>
Sound Power Level	Nom.	dB (A)	54

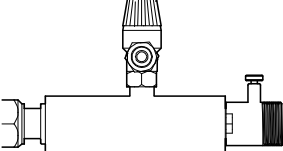

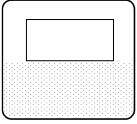
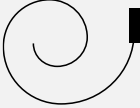
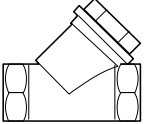
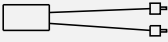
## 16 Accessories

Installation Manual	1		
User Manual	1		
Connecting pipe assembly (Including safety valve)	1		Connected to the water-outlet pipe side
Water discharge hose	1		Connected to the outlet of the drainage pan
Wired controller	1		To control the unit
Water temperature sensor	1		For detecting water tank temperature
Y-shaped filter	1		Connected to the water-inlet pipe side
Magnetic ring	2		
Cable tie	6		Fixing the wire and magnetic ring

Page intentionally left blank

Page intentionally left blank

Page intentionally left blank

FOR OVER 30 YEARS WE HAVE BEEN  
OFFERING SOLUTIONS TO ENSURE  
SUSTAINABLE COMFORT AND THE WELL-  
BEING OF PEOPLE AND THE ENVIRONMENT

[www.clivet.com](http://www.clivet.com)



sales and assistance

HWM-2-XMI 140- BT20G233GB-00



**CLIVET SPA**

Via Camp Lonc 25, Z.I. Villapaiera  
32032 Feltre (BL) - Italy

Tel. +39 0439 3131 - Fax +39 0439 313300

[info@clivet.it](mailto:info@clivet.it)

A Group Company of

