



*High efficiency air cooled
reversible heat pump for
outdoor installation*

ELFOENERGY LARGE² WSAN-XEE 352-802 RANGE



TECHNICAL BULLETIN



SIZE	352	402	432	452	502	552	602	702	802
HEATING CAPACITY KW	99,2	115	126	134	144	165	182	211	233
COOLING CAPACITY KW	85,1	97,2	106	114	123	141	156	183	203



Cost or reliability?

The dilemma of modern system engineering applications

Air-conditioning systems in trade centres influence both the starting investment and monthly management costs, for the whole of their working lives.

This theme is even more relevant in residential applications with centralised systems. Furthermore, maximum working flexibility requirements should be added to that, in serving different users while avoiding wasting energy and thus, money.

Finally, there are several industrial applications which require hot or chilled water as service fluid, process fluid or vector fluid for operator comfort and for conserving goods and enabling cycles to function correctly. Furthermore, in all these cases, the working reliability of the system is decisive.



High efficiency hydronic systems

The high efficiency hydronic systems are extremely versatile, reliable and widespread

Despite their apparently low costs, split, multi-split and VRF direct expansion systems have a lot of limits in these applications. For example, they require a separate system for primary air treatment.

The pipes that contain the refrigerant cross the served rooms and therefore they are subject to restrictions and use limitations. They cannot operate in the FREE-COOLING mode, the high efficiency and convenient mode that allows energy savings.

The hydronic systems are certainly more complete and versatile. They make it possible to adopt various types of terminals in the served environment, from fan coil units exposed or integrated in the furnishings, up to radiant or induction systems. They are also irreplaceable in the service and process industrial applications.

The main component performances, like air-cooled liquid chillers and hydronic heat pumps, are checked and certificated by appropriate certification programs, as Eurovent.



Clivet technological evolution

Clivet chillers reduce consumption and are compact and reliable

With over twenty years of technological evolution, Clivet liquid chillers and heat pumps represent the state of the art in air-conditioning of residential, trade and industrial environments.

Their success is based on high energy efficiency, compactness and management maintenance simplicity, with wide versatility in the choice of the most suitable model for the specific use.



ELFOEnergy Large²

Provides all Clivet technological developments for their medium capacity hydronic systems

High efficiency Scroll compressors, high performance heat exchangers, electronic control fans, fully automatic operation: these are only some of the technologies available with ELFOEnergy LARGE², in a range of models that are ideal for high capacity air conditioning systems in commercial, residential and industrial buildings.



- ELFOEnergy Large² stands out for its extremely high energy efficiency with operation at both partial and full load (class A unit based on Eurovent's efficiency rating in heating*)
- Furthermore, ELFOEnergy Large² with its numerous configurations, can be completed with most common system options built-in.

* The units from size 452 to size 802 are class A units based on Eurovent's efficiency rating in heating



Advantages

High efficiency all year round

ELFOEnergy Large² reversible heat pump is optimized for heating operation, with performances in class A in standard version with ECOBREEZE fans.

It reduces yearly energy consumption thanks to its high part-load efficiency i.e., by far the most frequent condition throughout the system's life-cycle.

This way, even the value of the served building increases. The main components are manufactured on an industrial scale, with maximum manufacturing reliability and can be easily found as spare parts.



System simplification

All of the features are provided by Clivet already assembled and tested built-in, differently then other manufacturers who make numerous additional components available to be installed on site.

Compact and versatile

Suitable for any type of terminals, from fan coils to radiant systems and cold beams, ELFOEnergy Large² heat pump is also available in Supersilent configuration. Energy recovery for producing hot water free of charge.

To further increase energy efficiency in a system with several ELFOEnergy Large² units operating on the same equipment, there is the innovative ECOSHARE feature, which automatically distributes the load and activates the necessary pumps.

Comfort and energy saving in one solution

Maximum efficiency is necessary with a part load

The system is required to generate maximum capacity only for a short amount of time.

Therefore, it is essential to have the maximum efficiency under part-load conditions.

This is the only way to actually reduce overall yearly consumptions.

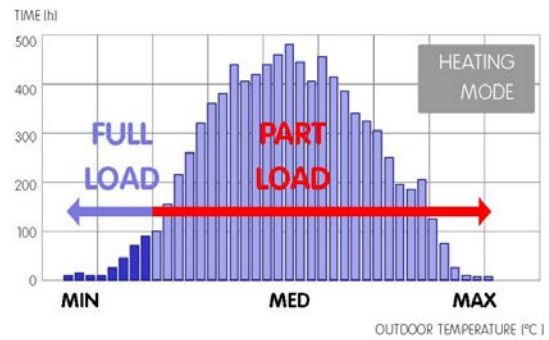

Part load efficiency determines the seasonal efficiency

In cooling mode, seasonal efficiency is conventionally represented by ESEER parameters according to Eurovent and IPLV parameters according to ARI.

Both give great importance to part-load operation, since it is the predominant condition.

SYSTEM LOAD	WEIGHT (ESEER) *	WEIGHT (IPLV) *
100%	3%	1%
75%	33%	42%
50%	41%	45%
25%	23%	12%

* EUROVENT (ESEER) supply times reference and ARI (IPLV) reference for seasonal efficiency calculations in the cooling operating.

The units for the production of hot and cold water with a capacity between 80 and 200 kW, represent 30% of the overall market.

On this basis, the Clivet mission must be the design and construction of units that satisfy the expressed needs of investors and traders who buy and use such units, both in terms of energy efficiency, low power consumption and compliance the environment, in terms of quick installation and high reliability.

High production efficiency

Since the maximum power generated by the system is requested only for short periods of time, it is fundamental to dispose of the maximum efficiency in the conditions of part-load.

This is the only way to actually reduce overall yearly consumptions.

The maximum efficiency at part-load is the result of a combination of technologies:

- use more scroll compressors arranged in parallel on the same circuit
- optimal choice of exchange surfaces

The availability of compressors of different sizes arranged in parallel on a single circuit can also allow more capacity steps. When operating at partial load the single compressor can use the whole exchange surfaces.

Therefore the operating temperatures improve significantly, increasing both the efficiency of each compressor and the efficiency of the whole system.

The unit management, mounted on board, activates resources in order to faithfully follow the loading, favouring the maximum efficiency conditions and starting up the resources with the method of minimal wear of the components.



Efficient and silent ventilation technology

Advanced aerofoil fans

The external axial fans are equipped with the innovative Winglet airfoil-vane with integrated baffle, able to increase the aerodynamic efficiency.

It results in a consumption reduction of the 10% and a medium sound emission lower of 6 dB than the traditional fans.

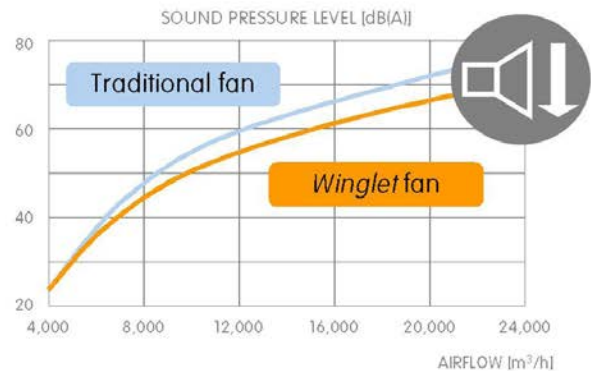
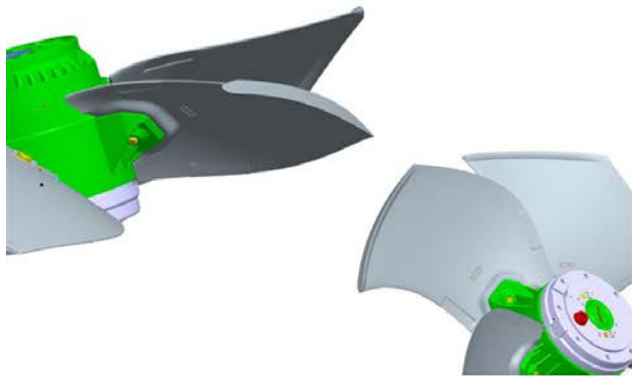

The ECOBREEZE technology at electronic control

With ECOBREEZE, the electric motor with an external rotor is driven by the continuous magnetic switching of the stator, deriving from the integrated electronic control.

The advantages are:

- 70% increase in efficiency thanks to the brushless technology and the special electricity supply;
- increase in the working life, thanks to the elimination of the brush wear;
- Reduction in the electrical consumption by the system, thanks to a drastic reduction of the inrush current for the fans obtained using the integrated 'Soft starter' function.



Fans at variable speed for minimal noise emission

All the ELFOEnergy Large² units fitted with ECOBREEZE fans are supplied with a condensation electronic control, which automatically reduces the fan speed as the heat load drops.

Since the fans are the unit's main noise source, the benefits are evident especially during the night hours, when the load is reduced but sensitivity to noise is enhanced.

All this translates into a reduction of sound pressure down to 8 dB(A) compared to full load operation in 90% of operating time of the unit.

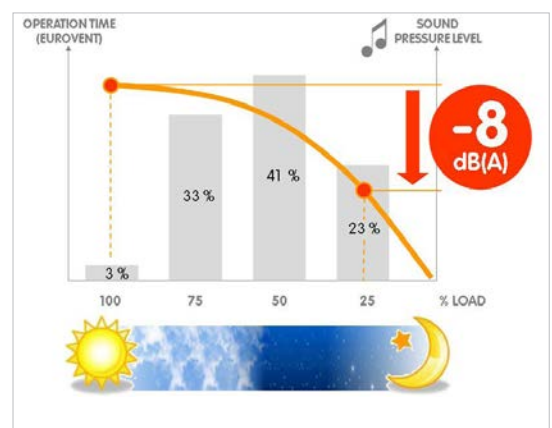

Superior flexibility and reliability

Efficient precision

The sequential activation logics of ELFOEnergy Large² compressors allow:

- accurately following the load heating/cooling, supplying better comfort;
- reducing the number of compressor start-ups which is the main cause for wear and tear
- increasing the life cycle of the unit
- reducing time and costs for any repairs, thanks to the modularity of components, their reduced dimensions and the lower cost compared to semi-hermetic compressors.

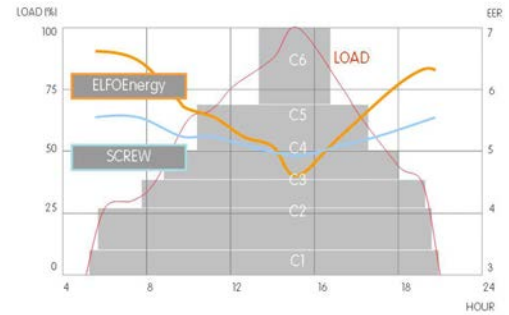

THE NUMBER OF START-UPS DECREASES THEREFORE THE LIFE CYCLE INCREASES

Stable and reliable operation

The electronic expansion valve (EEV) adapts rapidly and precisely to the actual load required for usage, allowing stable and reliable adjustment in comparison with mechanical thermostatic valves (TEV). This results also in a further increase in efficiency and longer compressor life.

The overheating control allows preventing phenomena that are hazardous to the compressors, such as overtemperature and return fluids, thereby increasing even more efficiency and durability.

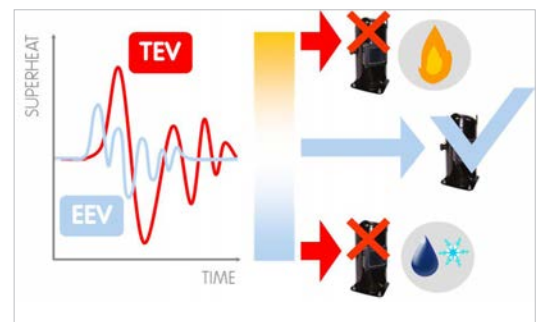

Simplified maintenance

Besides being efficient, ELFOEnergy Large² improves the system maintenance.

Indeed, the malfunction of a compressor does not compromise overall operation.

Moreover, Scroll compressors have a very compact design, are easy to find and easy to handle in case of replacements.



Practically unstoppable

ELFOEnergy Large² can operate even if the operation limits are temporarily exceeded. This occurs by increasing the fan speed at first and then passing to part-load condition (units equipped with ECOBREEZE fans).

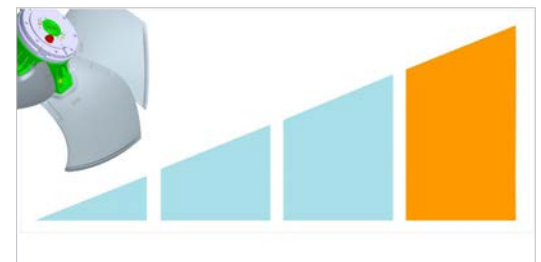

Controlled power supply

Proper power supply ensures optimal unit operation and protects its many electrical components.

The phase monitor, standard supplied:

- controls the presence and the exact sequence of the phases
- checks any voltage anomalies (-10%)
- automatically restarts the unit as soon as the proper power supply is restored.

The monitor is a multifunction type, where limit values and the service schedule of Clivet's Technical Support can be modified.

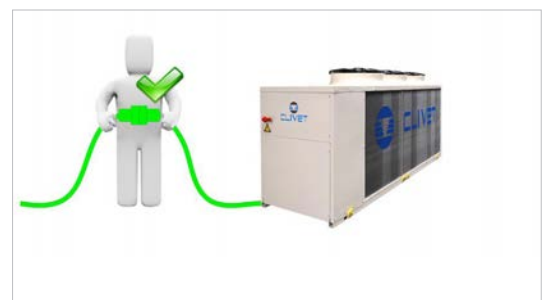

Advanced heat pump

The electric Heat pump technology promotes and provides incentives by the European Union with specific standards, such as the EU Directive 2009/28/CE of April 23rd 2009 that recognises ambient heat as a renewable source.

Compared to a combustion system, the electric heat Pump allows:

- Energy saving and reduction of the CO₂ emissions by an average of 50%
- Use of electric energy, increasingly produced through alternative and renewable sources
- Operation and reduced maintenance reliability
- No fossil combustion and therefore absence of chimney, absence of periodical controls on the emissions in the ambient and no local production of fine dust
- Cost reduction of first investment with the reversible models that use a single system for both heating and cooling.

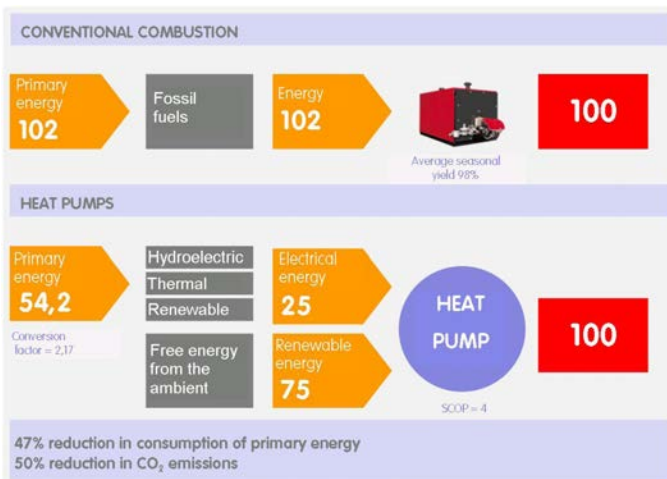

In heating mode, the reversible heat pump range by ELFOEnergy Large² offers high efficiency in both full load operation and part-load. The energy saving cycle operation throughout the year is noteworthy, thanks to the brilliant half-load performance even when in cooling mode. This result was aided with precise technological choices and a long history of specialised experience.

Coils protected against the formation of ice

The advanced heat pumps particular technology for this unit, guarantees its continued and reliable operation.

The ICE PROTECTION SYSTEM device prevents icing on the base of the external exchanger during winter operation, thanks to a special subcooling circuit.

This prevents damages caused by freezing.



Smart management of defrosts

The automatic defrost cycles on the remaining external exchanger surface are managed in predictive mode, reducing both the frequency and the duration. The electronics on board analyse not only the external conditions, but also the evaporation pressure variation in the exchanger.



High efficient refrigerant

R410A is the mix of two refrigerants used in equal parts: R32 that supplies the heating capacity and R125 that controls the flammability. It is a chlorine free refrigerant (HFC) with numerous advantages:

- ODP (Ozone Depletion Potential) = 0
- High volumetric effect thanks to the high coefficient global heat exchange and to the pressure variation (glide) which is almost nil during the evaporation phase

Elevated density and efficiency, with greater compactness of the refrigeration circuit and therefore the responsible use of materials and small refrigerant quantity, for a reduced environmental impact.

R-410A

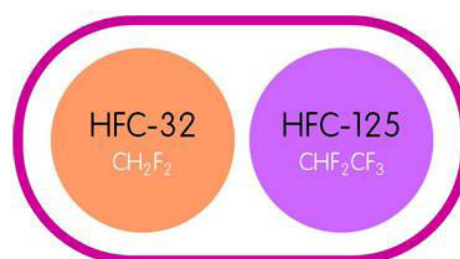

The automatic control device coordinates resources ensuring maximum efficiency

Operating completely automatic

The microprocessor control automatically manages operation according to the maximum efficiency criterion and includes many safety and alarm management functions.

It also includes advanced functions, such as daily and weekly programming and automatic maximum power consumption limitation (demand limit).

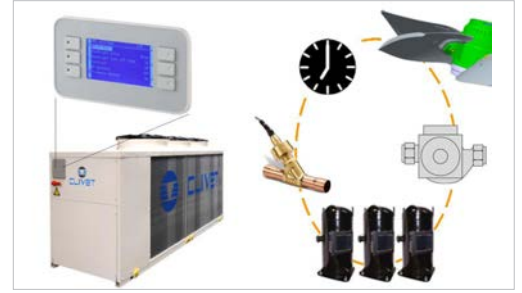

Versatility

The various supply temperatures that can be set, make ELFOEnergy Large² perfectly suitable for various types of systems, such as:

- heat integration for water loop systems
- distribution to terminal units, such as fan coils or other air treatment units
- distribution to radiant panels, induction terminals or chilled beams



PERFECT FOR THE VARIOUS TYPES OF SYSTEMS

Modularity

In the event of particularly large buildings requiring high capacities, it is advisable to use several units.

The ELFOEnergy Large² units are designed to be connected in parallel in modular logic, thereby granting the following advantages:

- increased flexibility, enhanced by the adjustment that can adapt to the load
- increased reliability, since the malfunction of one unit does not compromise the capacity supply of the other units
- increased efficiency, since energy is produced where and when required, according to the area served.

The microprocessor control combined with ECOSHARE allows controlling up to 7 units in local network (1 Master unit and 6 Slave).

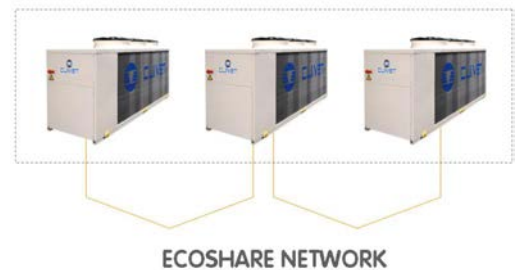

ECOSHARE ENHANCES THE BENEFITS OF MODULAR SCROLL TECHNOLOGY

Remote system management

The unit is standard equipped with:

- potential-free contact for remote on-off control
- potential-free contacts for remote display of the compressor status
- settings from user interface Off / Local on / Serial on
- potential-free contact for the remote control of any alarms

The various communication protocols allow the unit to exchange information with the main supervision systems by means of serial connections.



ELFOEnergy Large² technology industrialised the system

ELFOEnergy Large² can be supplied equipped with components that are often separately provided. So are reduced:

- design time: all the accessories are created to guarantee the best overall performance;
- installation costs: the accessories which are already mechanically connected, electrically wired and individually checked are ready to start operating immediately;
- the dimensions: the unit integration of the installation parts reduces the shafts and increases the space for other uses.

Built-in inertial accumulation available

In most ELFOEnergy Large² systems it can be installed without inertial accumulation on the system.

The unit in fact adapts to load very quickly, thanks to the compressor modularity, electronic thermostatic valve, plate exchangers at low water content.

However, in the event of hydraulic distribution networks with reduced dimensions, it is important to provide the system with an hydraulic flywheel. In such cases, inertial accumulation is available built-in, equipped with insulating coating and all the necessary safety devices. This allows eliminating installation times and costs and freeing space inside the building.

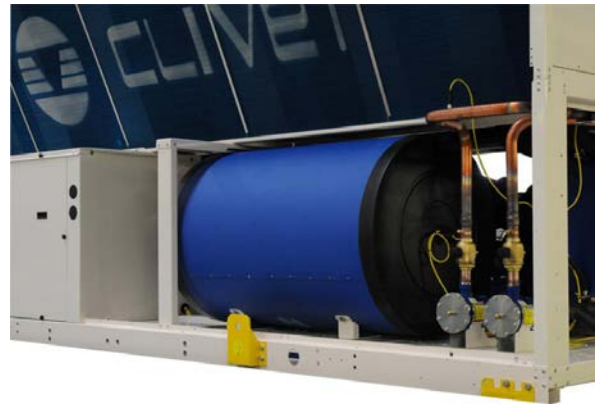

Configuration flexibility

Depending on the requirements of the system, the accessories can be configured so as to answer different requirements in a single solution.

The pumping unit available in versions:

- **Single pump:** in the configurations shown below
- **Double pump:** in this configuration, one pump is foreseen as reserve to the other. The microprocessor automatically balances the hours of operating of both pumps and, in case of fault, the unit signal the block of the out of service pump.
- **Hydropack with 2 pumps:** the pumps operating in parallel. Thanks to this modularity the water flow rate can be automatically reduced if the temperature increases above the operating range. The device appears very useful during start-ups, week-end pauses or after a long period of inactivity. When the temperature of the water in the hydronic circuit is particularly high, unwanted locks due to overload are avoided and consequent interventions of specialised staff for assisted start-up. In case of pump failure, the unit continues to operate providing 60% of rated capacity.

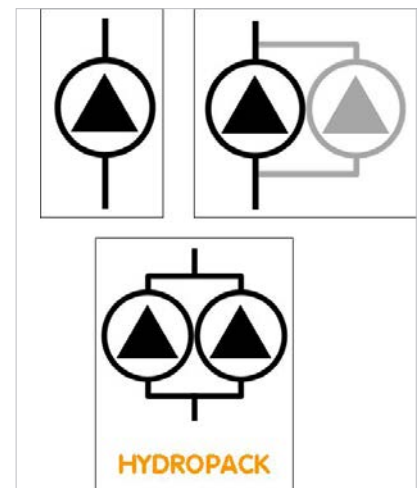

Even the primary circuit can be integrated built-in

A connection to the secondary use circuit is all that's needed. In this way, the system results even more simple and reliable.

The units are complete with quick connections on the hydraulic side, which further reduce start-up times by eliminating pipe threading operations.

Furthermore, other system components are also available as accessories, such as hydraulic connections reported on the external walls of the unit and the required water filter.

ELFOEnergy Large² MAY INCLUDE MOST OF SYSTEM COMPONENTS

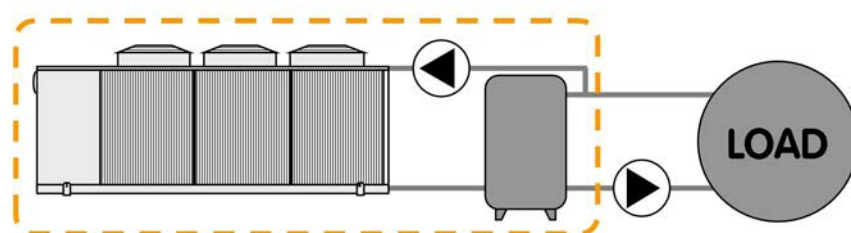

THE QUICK CONNECTIONS ARE STANDARD SUPPLIED

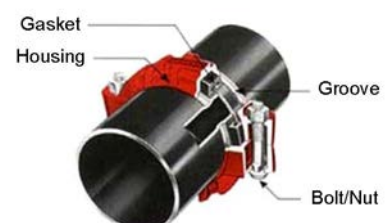

Produces hot water freely

In the cooling operating the condensation heat recovery can be:

- Partial: it recovers about the 20% of the available heat (desuperheater)
- Total: it recovers the 100% of the available heat

It allows the free DHW production for:

- Hot water coil supply for reheat
- Domestic hot water production (with intermediate exchanger)
- Other processes or operations

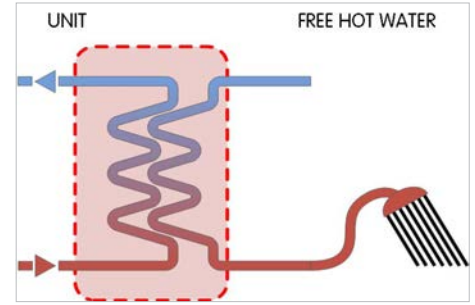

Even for low water temperature

The unit is also perfectly adapted for use in process cooling where the low temperature version (Brine) together with the addition of glycol to the thermo-vector liquid produces chilled water down to -8°C .



Demand limit

The partial or total activation of the compressors can be disabled to limit the overall electric capacity absorbed

The external signal is of analogical type 0-10 V / 4-20 mA. The greater the signal, the lower the capacity that the unit is enabled to deliver, activating the compressors and fans.

The Demand Limit function does not act on the control.

The Demand Limit function on the reversible heat pump models can affect any automatic defrosting cycles. In these conditions, the user can therefore decide to limit its activation.



The represented number of compressors constitutes an indicative example

A unique system for summer and winter

Thanks to its versatility, the heat pump is the packaged solution that serves to the system in the summer and in the winter.

A great opportunity for renovation of present installation in the name of the reduction of consumption and energy efficiency

Heating and air-conditioning systems have seen radical changes both in technical and consumption terms in the tertiary sector and in collective applications over the last 15 years.

Recent European level normative regulations make these systems obsolete, inefficient and are causing demand for requalification investments from property administrators and managers to improve efficiency and reduce consumption and polluting emissions.

Efficient use of energy with heat recovery

In almost all systems fitted with a chiller used to produce chilled water there is also the need to have hot water. The recovery of condensation heat is an efficient way of producing hot water while the chiller is in operation. It has the double benefit of both reducing the heat load to the condenser, thereby eliminating dissipation costs and generating free hot water, thereby reducing the costs of the auxiliary heater.

Application versatility of recovery devices

The hot water produced by heat recovery can be used in a number of ways: to reheat air in handling units, to preheat hot water for domestic use or industrial processes, to heat up water in swimming pools, showers and spas, to preheat hot water for laundries or industrial kitchens.



Post-heating in air handling units to control humidity levels in hospitals and labs



Preheating of hot water for domestic use or for industrial process



Heating of water in swimming pools, showers and SPAS



Preheating of hot water for laundries and industrial kitchens

Water heating up

The heat recovery device can be used to cover the entire heat load required. The hot water supply temperature is controlled via a modulating control valve that needs to be fitted on the system at the outlet of the recovery unit. The auxiliary heating device is recommended to cover the thermal energy demand when the chiller is not in operation or is operating at part load.

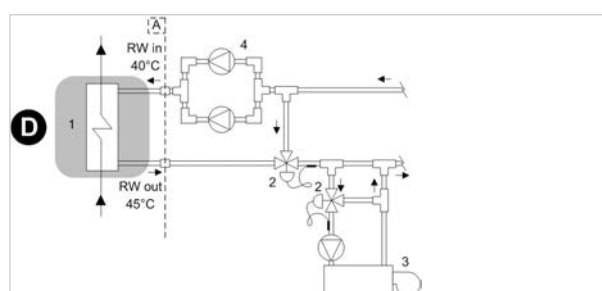

Example of how heat recovery is used to cover the entire heat demand and control the operating temperature

Water preheating

The heat recovery device can be used to preheat water at the inlet of the main heating device (e.g. boiler). In this case, the demand for hot water is greater than the amount of heat recovered by condensation and the recovery device only covers part of the required heat load. By preheating the water, heating consumption levels are therefore reduced and the main heating device has a lower installed power requirement.

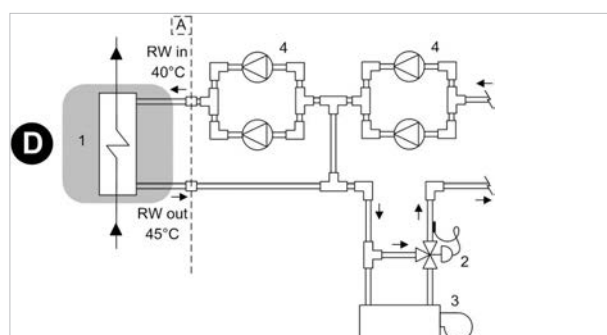

Example of how heat recovery is used to preheat hot water in the system

Domestic hot water production

The heat recovery device can be used to produce water for domestic use. In order to prevent contamination of domestic water with the chiller's process fluid, it is necessary to insert an intermediate heat exchanger. Using an inertial heat storage tank allows to have a reserve of preheated water and enables the intermediate exchanger to operate more efficiently.

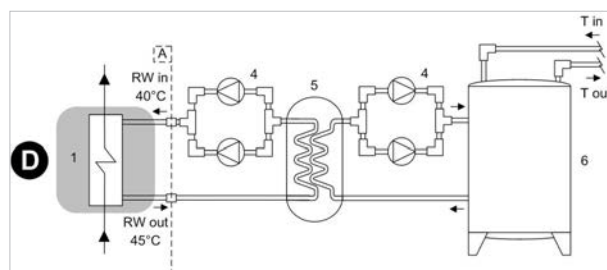

Example of how heat recovery is used to preheat hot water for domestic use

- | | |
|--|--|
| A - Unit supply limit | D - Partial energy recovery |
| 1 - Recovery exchanger | 2 - Control modulating valve |
| 3 - Auxiliary heating device (ex.boiler) | 4 - Electric pump with standby pump |
| 5 - Intermediate heat exchanger | 6 - Inertial heat storage |
| RW in - Recovery water inlet | RW out - Recovery water outlet |
| T in - Drinkable water inlet | T out - Drinkable water outlet to the auxiliary heater |

The diagrams refer to partial energy recovery, though they also apply to total energy recovery (Clivet R). Please note that the diagrams are only meant as a guide.

Standard unit technical specifications

Compressor

Hermetic orbiting scroll compressor complete with motor over-temperature and over-current devices and protection against excessive gas discharge temperature. Fitted on rubber antivibration mounts and complete with oil charge.

An oil heater, which starts automatically, keeps the oil from being diluted by the refrigerant when the compressor stops.

The compressors are connected in TANDEM on a single refrigerating circuit. They have a biphasic oil equalisation.

Structure

The bearing structure is made from hot-galvanized and painted plate and the external panelling from pre-painted aluminium (RAL9001), ensuring maximum weatherability. The uniform unit weight distribution is guaranteed by the base structure, realized with galvanized and painted plate section bars, featuring holes and/or brackets to simplify the unit lifting and earthing.

The entire structure has been sized with modern calculation tools and finished elements to ensure the maximum safety and sturdiness of the system.

Panelling

External pre-painted aluminium panelling that ensures superior resistance to corrosion for outdoor installation and eliminates the need for periodical painting. The panels can be easily removed to fully access internal components and are lined with sound-proof material on the inside to contain the unit's sound levels.

Internal exchanger

Direct expansion heat exchanger with braze welded stainless steel INOX AISI 316 plates and complete with external thermal/anti-condensation insulation.

The exchanger is complete with:

- differential pressure switch, water side
- antifreeze heater to protect the water side exchanger, preventing the formation of frost if the water temperature falls below a set value.

External exchanger

Direct expansion finned coil exchanger made with copper pipes placed on staggered rows mechanically expanded to better adhere to the fin collar. The fins are made from aluminium with a corrugated surface and adequately distanced to ensure the maximum heat exchange efficiency.

Correct power supply to the expansion valve is ensured by the under-cooling circuit.

This circuit also prevents the formation of ice at the base of the heat exchanger during winter operation.

Protective coverings available on request.

Fan

ECOBREEZE device (STD)

Axial fans with sickle profile blades terminating with winglets, directly coupled to the electronic controlled motor (IP54), driven by the magnetic commutation of the stator. The brushless technology and the special supply increase both the life expectancy and the efficiency. As a result the electric consumption is reduced up to 50%. Fans are housed in aerodynamically shaped structures to increase efficiency and reduce noise level. The assembly is protected by accident prevention guards.

Supplied with variable speed control.

Refrigeration circuit

Refrigeration circuit with:

- replaceable anti-acid solid cartridge dehydrator filter
- sight glass with moisture and liquid indicator
- liquid receiver
- electronic expansion valve
- non-return valve
- 4-way reverse cycle valve
- high pressure safety pressure switch
- low pressure safety switch
- high pressure safety valve
- low pressure safety valve
- cutoff valve on liquid line
- solenoid valve on the liquid line

Electrical panel

The capacity section includes:

- main door lock isolator switch
- isolating transformer for auxiliary circuit power supply
- compressor circuit breakers
- fan overload circuit breakers
- compressor control contactor

The control section includes:

- interface terminal with graphic display
- display of the set values, the error codes and the parameter index
- ON/OFF and alarm reset buttons
- proportional-integral-derivative water temperature control
- daily, weekly programmer of temperature set-point and unit on/off
- unit switching on management by local or remote (serial)
- antifreeze protection water side
- compressor overload protection and timer
- prealarm function for water anti-ice and high refrigerant gas pressure
- self-diagnosis system with immediate display of the error code
- automatic compressor start rotation control
- compressor operating hour display
- input for remote ON/OFF control
- Input for remote HEAT/COOL control
- relay for remote cumulative fault signal
- inlet for demand limit (power input limitation according to a 0÷10V external signal)
- digital input for double set-point enabling
- potential-free contacts for compressor status
- multifunction phase monitor

Configurations

D - Partial energy recovery

R - Totale energy recovery

B - Low water temperature

SC - Acoustic configuration with compressor soundproofing

EN - Extremely low noise acoustic configuration

Accessories - hydronic assembly

- Standard pump (n.b.: other types are available by head)
- Standard pump with standby pump (n.b.: other types are available by head)
- HYDROPACK (n.b.: other types are available by head)
- Storage tank
- Storage tank with primary circuit built-in the unit (n.b.: only for units complete with a Standard pump / Standard pump with a standby pump).
- Steel mesh mechanical strainer (accessory separately provided). Note: To be located at the exchanger inlet. We disclaim any liability and make the guarantee void, if an appropriate mechanical filter is not provided inside the system.

Accessories

- Finned coil protection grill
- Anti-hail protection grilles
- Copper / aluminium condensing coil with acrylic lining
- Copper/copper condensing coil with Energy Guard DCC Aluminum treatment
- High and low pressure gauges
- Electrical panel ventilation
- Electrical panel antifreeze protection
- Power factor correction capacitors (cosφ > 0.9)
- ECOSHARE function for the automatic management of a group of units
- Breakaway current reducing device (SOFT STARTER)
- Serial communication module for BACnet supervisor
- Serial communication module for Modbus supervisor
- Serial communication module for LonWorks supervisor
- Device for consumption reduction of the external section at variable speed (phase-cutting)
- Remote control via microprocessor remote control (accessory separately supplied)
- Mains power supply unit (accessory separately supplied)
- Energy meter
- Set-point compensation with signal 0-10 V
- Set-point compensation with outdoor air temperature probe
- Functioning limits extension kit up to -10°C (W.B.)
- Spring antivibration mounts (supplied separately)

On request are available:

- copper / copper condensing coils with brass shoulders

Test

All the units are factory-tested in specific steps, before shipping them. After the approval, the moisture contents present in all circuits are analyzed, in order to ensure the respect of the limits set by the manufacturers of the different components.



General technical data

Size			352	402	432	452	502	552	602	702	802
Cooling											
Cooling capacity	1	kW	85,1	97,2	106	114	123	141	156	183	203
Compressor power input	1	kW	29,3	33,1	37,6	40,2	44,8	46,7	56,2	60,9	70,4
Total power input	2	kW	32,3	35,9	40,8	43,1	48,1	50,8	60,2	66,2	75,9
Total recovery heating capacity	3	kW	112	127	141	151	164	183	208	239	267
Partial recovery heating capacity	3	kW	28,1	31,9	35,6	37,7	41,3	45,8	52,4	59,9	67,0
EER	1		2,64	2,70	2,60	2,65	2,55	2,77	2,59	2,76	2,67
Cooling capacity (EN14511:2013)	4	kW	84,4	96,7	105	114	122	140	156	183	202
Total power input (EN14511:2013)	4	kW	32,7	36,5	41,3	43,6	48,5	51,3	60,8	66,9	76,5
EER (EN 14511:2013)	4		2,58	2,65	2,55	2,61	2,52	2,73	2,56	2,73	2,64
SEER	10		3,37	3,50	3,40	3,57	3,52	3,62	3,47	3,66	3,50
Heating											
Heating capacity	5	kW	99,2	115	126	134	144	165	182	211	233
Compressor power input	5	kW	29,2	33,2	36,9	39,4	42,2	46,2	52,3	59,2	66,2
Total power input	2	kW	32,0	36,0	39,7	41,5	45,1	50,3	56,4	64,5	71,6
COP	5		3,10	3,20	3,18	3,23	3,20	3,27	3,22	3,28	3,25
Heating capacity (EN14511:2013)	6	kW	101	116	127	136	147	165	183	212	234
Total power input (EN14511:2013)	6	kW	32,6	36,7	40,4	42,1	45,8	51,1	57,1	65,3	72,6
COP (EN 14511:2013)	6		3,08	3,16	3,14	3,23	3,20	3,24	3,21	3,25	3,23
SCOP - AVERAGE Climate - W35	10		3,40	3,41	3,48	3,54	3,54	3,48	3,49	3,44	3,40
Compressor											
Type of compressors			SCROLL	SCROLL	SCROLL	SCROLL	SCROLL	SCROLL	SCROLL	SCROLL	SCROLL
No. of compressors		No	2	2	2	2	2	2	2	2	2
Rated power (C1)		HP	35	40	43	45	50	55	60	70	80
Std Capacity control steps		No	3	3	3	3	3	3	2	3	2
Oil charge (C1)		l	8,00	10,0	12,0	10,0	11,0	13,0	13,0	13,0	13,0
Refrigerant charge (C1)	7	kg	39	43	48	50	54	58	61	67	72
Refrigeration circuits		No	1	1	1	1	1	1	1	1	1
Internal exchanger											
Type of internal exchanger	8		PHE	PHE	PHE	PHE	PHE	PHE	PHE	PHE	PHE
Water flow rate (Utility Side)	1	l/s	4,10	4,60	5,10	5,50	5,90	6,70	7,40	8,70	9,70
Internal exchanger pressure drops	1	kPa	39	40	40	28	28	27	30	28	31
Water content		l	4,80	5,50	6,10	8,00	8,90	10,1	11,1	14,2	15,8
Min. installation water contents	11	l	694	805	895	925	1008	1122	1274	1456	1631
External exchanger											
Quantity		No	2	2	2	2	2	2	2	2	2
Front surface		m ²	6,30	6,30	6,30	6,30	6,30	8,90	8,90	11,6	11,6
External Section Fans											
Type of fans	9		AX	AX	AX	AX	AX	AX	AX	AX	AX
Number of fans		No	2	2	2	2	2	3	3	4	4
Standard airflow		l/s	12497	12281	12281	12217	12105	18255	18255	24267	24267
Connections											
Water connections			2"1/2	2"1/2	2"1/2	2"1/2	2"1/2	2"1/2	2"1/2	2"1/2	2"1/2
Power supply											
Standard power supply		V	400/3/50	400/3/50	400/3/50	400/3/50	400/3/50	400/3/50	400/3/50	400/3/50	400/3/50
Standard unit weights											
Shipping weight		kg	910	970	1053	1093	1117	1315	1330	1535	1550
Operating weight		kg	915	975	1059	1101	1126	1326	1341	1549	1564

The Product is compliant with the Erp (Energy Related Products) European Directive. It includes the Commission delegated Regulation (EU) No 811/2013 (rate heat output < 70 kW at specified reference conditions) and the Commission delegated Regulation (EU) No 813/2013 (rated heat output < 400 kW at specified reference conditions).

*Contains fluorinated greenhouse gases (GWP 2087,5)

- Data referred to the following conditions: Internal exchanger water temperature = 12 / 7 °C. External exchanger inlet air temperature = 35°C
- The Total Power Input value does not take into account the part related to the pumps and required to overcome the pressure drops for the circulation of the solution inside the exchangers
- Recovery exchanger water=40/45°C
- Data calculated in accordance with EN14511:2013 regulations referred to the following conditions: internal exchanger water temperature = 12/7 °C air entering the external exchanger = 35°C
- Data referred to the following conditions: Internal exchanger water temperature = 40/45 °C. External exchanger air temperature 7 D.B. /6.1°C W.B.
- Data calculated in compliance with Standard EN 14511:2013 referred to the following conditions: Internal exchanger water temperature = 40/45 °C. external exchanger air temperature 7 D.B. /6°C W.B.
- Indicative values for standard units with possible +/-10% variation. The actual data are indicated on the label of the unit.
- PHE = plates
- AX = axial fan
- Data calculated according to the EN 14825:2016 Regulation
- The calculated water volume to the system does not consider the volume of water contained in the internal exchanger. With applications at low outdoor air temperature or low average loads requested, the minimum water volume to the system is obtained by increasing the indicated value by 40%.

Acoustic configuration: compressor soundproofing (SC)

Electrical data

Size			352	402	432	452	502	552	602	702	802
F.L.A. - Full load current at max admissible conditions											
F.L.A. - Total		A	76,1	84,5	90,1	98,8	104,5	117,0	131,4	150,0	164,5
F.L.I. - Full load power input at max admissible conditions											
F.L.I. - Total		kW	44,2	49,0	54,4	57,8	63,2	70,2	79,0	91,8	102,4
M.I.C. Maximum inrush current											
M.I.C. - Value		A	264,6	311,6	317,2	349,6	355,2	367,7	382,1	470,2	484,7

Voltage unbalance: max 2%

Power supply: 400/3/50 Hz +/- 10%

Electrical data refer to standard units; according to the installed accessories, the data can suffer some variations.

Operating range (Cooling)

Size			352	402	432	452	502	552	602	702	802
External exchanger											
Max entering air temperature	1	°C	45	46	45	45	44	46	45	46	46
Max entering air temperature	2	°C	50	50	50	50	50	50	50	50	50
Min. entering air temperature	3	°C	-10	-10	-10	-10	-10	-10	-10	-10	-10
Min. entering air temperature	4	°C	-7,0	-7,0	-7,0	-7,0	-7,0	-7,0	-7,0	-7,0	-7,0
Min. entering air temperature	5	°C	-2,0	-2,0	-2,0	-2,0	-2,0	-2,0	-2,0	-2,0	-2,0
Min. entering air temperature	6	°C	11	11	11	11	11	11	11	11	11
Internal exchanger											
Max inlet water temperature		°C	24	24	24	24	24	24	24	24	24
Min. outlet water temperature	7	°C	5,0	5,0	5,0	5,0	5,0	5,0	5,0	5,0	5,0
Min. outlet water temperature	8	°C	-8,0	-8,0	-8,0	-8,0	-8,0	-8,0	-8,0	-8,0	-8,0

1. Max inlet temperature - unit at full load
2. Max inlet air temperature - capacity-controlled unit with standard limit device
3. Min inlet air temperature - unit at full load and outdoor air at rest
4. Min inlet air temperature - unit at part load and outdoor air at rest

5. Min inlet air temperature - unit at partial load and air speed of 0.5 m/s.
6. Min inlet air temperature - unit at partial load and air speed of 1 m/s.
7. standard unit. external exchanger entering air 35°C
8. B = Low temperature. external exchanger inlet air 35°C. Fluid treated with 40% ethylene glycol

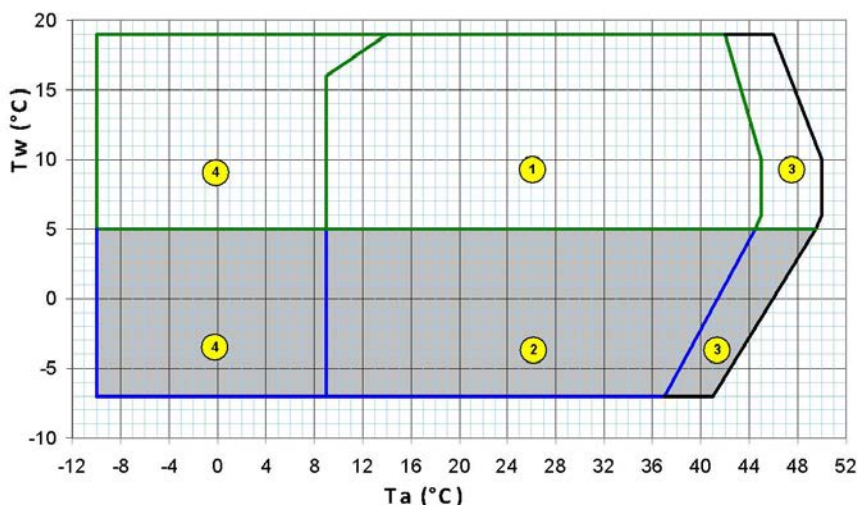

To = Entering air temperature to the external exchanger

Tw [°C] = Exchanger outlet water temperature

Graph informed to size 352, for more details for each size, refer to the table below.

1. Standard Version
2. Low temperature version "B" (fluid with ethylene glycol)
3. Capacity-controlled unit (automatic capacity control)
4. Full-load unit with air flow module

Acoustic configuration: compressor soundproofing (SC)

Operating range (Heating)

Size			352	402	432	452	502	552	602	702	802
External exchanger											
Max entering air temperature (WB)	1	°C	25	25	25	25	25	25	25	25	25
Min inlet air temperature (D.B.)		°C	-6,0	-6,0	-6,0	-6,0	-6,0	-6,0	-6,0	-6,0	-6,0
Min inlet air temperature (D.B.)	2	°C	-10	-10	-10	-10	-10	-10	-10	-10	-10
Internal exchanger											
Min. outlet water temperature		°C	25	25	25	25	25	25	25	25	25
Max water outlet temperature		°C	53	53	53	53	53	53	53	53	53

5. Unit at full load. internal exchanger water = 40/45 °C

6. Limit with option OHE

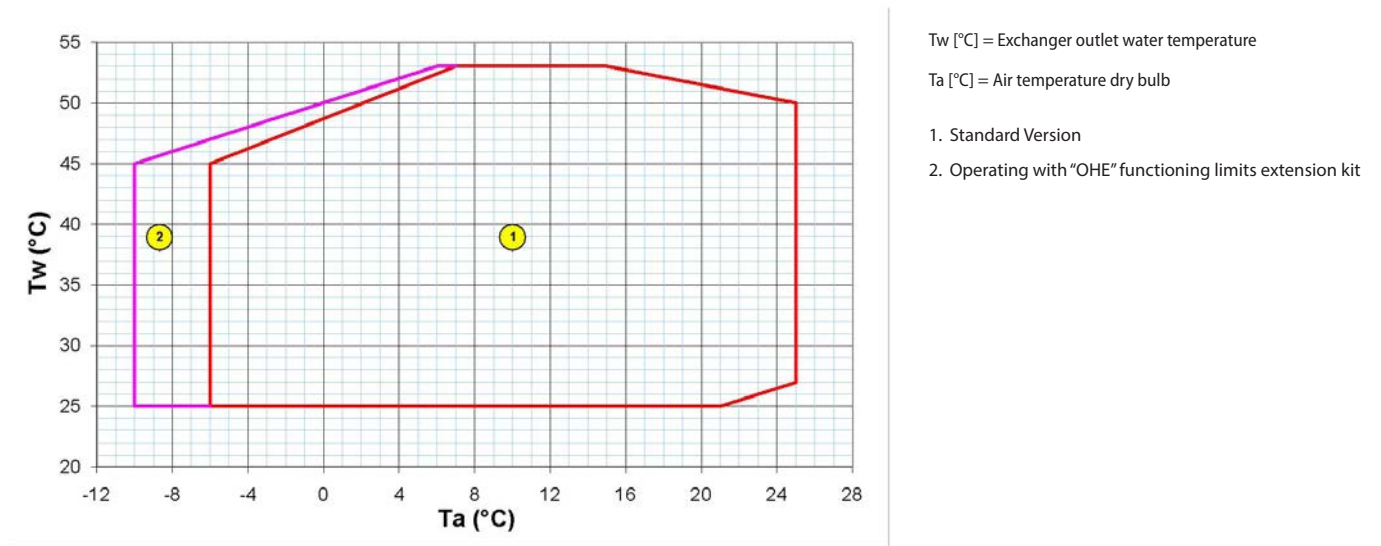

Tw [°C] = Exchanger outlet water temperature

Ta [°C] = Air temperature dry bulb

1. Standard Version
2. Operating with "OHE" functioning limits extension kit

Acoustic configuration: compressor soundproofing (SC)

Performances in Cooling

Size	To (°C)	Entering external exchanger air temperature (°C)													
		25		30		32		35		38		41		43	
		kWf	kWe	kWf	kWe	kWf	kWe	kWf	kWe	kWf	kWe	kWf	kWe	kWf	kWe
352	5	90,3	24,0	85,1	26,3	83,0	27,3	79,6	28,9	76,0	30,6	72,3	32,4	69,8	33,6
	6	93,2	24,3	87,9	26,6	85,7	27,6	82,3	29,1	78,9	30,7	75,4	32,4	72,9	33,5
	7	96,1	24,5	90,7	26,9	88,5	27,8	85,1	29,3	81,8	30,9	78,3	32,5	76,1	33,5
	8	99,1	24,8	93,5	27,2	91,3	28,1	87,9	29,6	84,6	31,1	81,3	32,6	79,1	33,6
	9	102	25,1	96,4	27,4	94,1	28,4	90,7	29,8	87,4	31,3	84,2	32,7	82,1	33,7
	10	105	25,3	99,2	27,7	96,9	28,7	93,6	30,1	90,3	31,5	87,1	32,9	85,0	33,8
402	5	103	26,8	97,5	29,5	95,1	30,6	91,3	32,5	87,3	34,6	83,1	36,7	80,2	38,2
	6	106	27,0	101	29,7	98,1	30,9	94,2	32,8	90,1	34,8	85,9	37,0	82,9	38,5
	7	110	27,3	104	30,0	101	31,2	97,2	33,1	93,0	35,1	88,7	37,2	85,6	38,7
	8	113	27,6	107	30,3	104	31,5	100	33,3	95,9	35,3	91,5	37,4	88,5	38,9
	9	116	27,9	110	30,6	107	31,7	103	33,6	98,9	35,6	94,4	37,7	91,3	39,1
	10	120	28,1	113	30,8	111	32,0	106	33,9	102	35,8	97,4	37,9	94,2	39,3
432	5	113	30,6	106	33,6	103	34,9	99,2	36,9	95,0	39,1	90,6	41,3	87,6	42,9
	6	117	30,9	110	33,9	107	35,2	103	37,3	98,2	39,4	93,7	41,6	90,7	43,2
	7	120	31,2	113	34,3	110	35,6	106	37,6	101	39,7	96,9	41,9	93,8	43,4
	8	124	31,6	117	34,6	114	35,9	109	37,9	105	40,0	100	42,2	96,9	43,7
	9	128	31,9	120	35,0	117	36,3	113	38,3	108	40,4	103	42,5	100	44,0
	10	132	32,3	124	35,3	121	36,6	116	38,6	111	40,7	107	42,8	103	44,3
452	5	120	32,9	114	36,1	111	37,5	107	39,6	103	41,8	98,5	44,1	95,6	45,6
	6	124	33,2	118	36,4	115	37,8	111	39,9	106	42,1	102	44,4	98,8	45,9
	7	128	33,5	121	36,8	118	38,1	114	40,2	110	42,4	105	44,6	102	46,2
	8	132	33,8	125	37,1	122	38,4	118	40,5	113	42,7	109	44,9	106	46,4
	9	136	34,2	129	37,4	126	38,8	121	40,9	117	43,0	112	45,2	109	46,7
	10	140	34,5	133	37,8	130	39,1	125	41,2	120	43,3	116	45,4	113	46,9
502	5	130	36,8	123	40,3	120	41,7	115	44,0	110	46,4	106	48,8	103	50,5
	6	134	37,2	127	40,7	123	42,1	119	44,4	114	46,7	109	49,1	106	50,8
	7	138	37,6	131	41,1	127	42,5	123	44,8	118	47,1	113	49,5	110	51,1
	8	143	38,0	135	41,5	131	42,9	126	45,2	121	47,5	116	49,9	113	51,5
	9	147	38,4	139	41,9	135	43,3	130	45,6	125	47,9	120	50,3	117	51,9
	10	151	38,8	143	42,3	139	43,7	134	46,0	129	48,3	124	50,7	120	52,3
552	5	148	38,3	140	42,0	137	43,6	132	46,0	127	48,5	122	51,2	118	53,0
	6	153	38,6	145	42,3	142	43,9	136	46,3	131	48,9	126	51,5	122	53,4
	7	158	39,0	150	42,7	146	44,3	141	46,7	135	49,2	130	51,8	126	53,6
	8	163	39,3	154	43,1	151	44,6	145	47,0	140	49,5	134	52,1	130	53,9
	9	168	39,7	159	43,4	155	45,0	150	47,4	144	49,9	138	52,4	134	54,2
	10	173	40,1	164	43,8	160	45,4	154	47,7	148	50,2	142	52,7	139	54,4
602	5	163	46,2	154	50,6	151	52,4	145	55,3	140	58,2	134	61,2	130	63,2
	6	169	46,8	160	51,1	156	52,9	150	55,7	145	58,7	139	61,7	135	63,8
	7	175	47,4	165	51,6	162	53,4	156	56,2	150	59,2	143	62,3	139	64,4
	8	180	47,9	171	52,1	167	53,9	161	56,7	155	59,6	148	62,8	144	64,9
	9	186	48,5	176	52,6	172	54,4	166	57,2	160	60,1	153	63,2	148	65,4
	10	192	49,0	182	53,1	177	54,8	171	57,6	164	60,6	158	63,7	153	65,8
702	5	192	50,2	182	54,8	178	56,8	172	60,0	166	63,4	160	67,0	156	69,6
	6	198	50,6	188	55,2	184	57,3	177	60,5	171	63,9	165	67,5	161	70,0
	7	205	51,0	194	55,7	190	57,7	183	60,9	176	64,3	170	68,0	165	70,5
	8	211	51,4	200	56,1	195	58,2	189	61,4	182	64,8	175	68,4	170	71,0
	9	217	51,8	206	56,6	201	58,6	194	61,8	187	65,3	180	68,9	175	71,4
	10	224	52,3	212	57,0	207	59,1	200	62,3	193	65,8	185	69,4	180	71,9
802	5	212	57,9	201	63,1	196	65,4	189	69,2	182	73,4	174	77,9	169	81,1
	6	220	58,4	208	63,7	203	66,0	196	69,8	188	73,9	181	78,4	176	81,5
	7	227	59,0	215	64,2	210	66,6	202	70,4	195	74,5	187	78,9	182	82,0
	8	235	59,5	222	64,8	217	67,2	209	71,0	201	75,0	194	79,4	189	82,5
	9	242	60,1	229	65,4	224	67,8	216	71,5	208	75,6	200	79,9	195	83,0
	10	249	60,6	236	66,0	230	68,3	222	72,1	214	76,2	206	80,5	201	83,5

kWf = Cooling capacity in kW

The data do not consider the pump share, required to overcome the pressure drop for the solution circulation inside the exchangers

kWe = Compressor power input in kW

To = Leaving water temperature on hydraulic circuit, cooling side (°C), load input/output = 5°C



Performance in Heating

Size	Ta (°C) DB/WB	External exchanger water inlet / outlet temperature (°C)									
		30 / 35		35 / 40		40 / 45		42 / 47		45 / 50	
		kWt	kWe	kWt	kWe	kWt	kWe	kWt	kWe	kWt	kWe
352	-5/-5,4	74,5	22,5	75,1	25,1	75,2	28,2	75,1	29,5	–	–
	0/-0,6	86,1	23,0	85,1	25,6	84,4	28,6	84,1	29,9	83,8	31,9
	5/3,9	97,9	23,5	95,7	26,0	94,0	29,0	93,6	30,2	93,0	32,2
	7/6,1	104,0	23,7	101,2	26,3	99,2	29,2	98,5	30,5	97,7	32,4
	10/8,2	109,9	23,9	106,8	26,5	104,3	29,4	103,5	30,7	102,5	32,7
	15/13	124,3	24,4	120,3	27,1	116,8	30,0	115,6	31,3	113,9	33,2
402	-5/-5,4	88,7	25,9	88,5	28,7	88,1	32,1	88,0	33,6	–	–
	0/-0,6	99,6	26,2	99,7	29,1	98,9	32,5	98,3	34,1	97,1	36,5
	5/3,9	112,1	26,5	111,0	29,5	109,7	33,0	109,2	34,5	108,3	37,0
	7/6,1	118,9	26,7	116,8	29,7	115,3	33,2	114,9	34,7	114,5	37,3
	10/8,2	126,0	26,9	122,5	29,9	120,8	33,4	120,6	35,0	121,0	37,5
	15/13	143,7	27,5	136,1	30,4	134,0	33,9	134,7	35,5	137,6	38,0
432	-5/-5,4	97,6	28,7	97,1	32,0	97,1	35,8	97,3	37,5	–	–
	0/-0,6	109,5	29,1	109,9	32,4	107,7	36,2	106,0	37,8	102,7	40,4
	5/3,9	122,4	29,6	123,1	32,9	119,6	36,6	116,9	38,2	111,7	40,8
	7/6,1	129,4	29,8	130,0	33,1	126,1	36,9	123,2	38,5	117,6	41,0
	10/8,2	136,5	30,1	136,8	33,4	132,7	37,1	129,8	38,7	124,1	41,3
	15/13	154,2	30,7	153,3	34,1	149,4	37,8	147	39,4	142,4	42
452	-5/-5,4	102,6	31,0	102,6	34,4	102,5	38,3	102,5	40,1	–	–
	0/-0,6	114,3	31,4	115,6	34,8	113,9	38,7	112,3	40,5	109,2	43,2
	5/3,9	127,9	31,7	129,4	35,2	126,8	39,2	124,7	40,9	120,3	43,6
	7/6,1	135,5	31,9	136,7	35,4	134,0	39,4	131,9	41,1	127,5	43,8
	10/8,2	143,3	32,1	144	35,6	141,4	39,6	139,4	41,3	135,4	44,1
	15/13	163,2	32,6	162	36,1	160,1	40,1	159,1	41,9	157,4	44,6
502	-5/-5,4	109,8	33,1	109,7	36,8	110,6	41,1	111,2	43,0	–	–
	0/-0,6	124,4	33,7	123,5	37,3	122,7	41,5	122,5	43,3	122,1	46,3
	5/3,9	140,1	34,2	138,6	37,8	136,6	42,0	135,7	43,7	134,2	46,6
	7/6,1	148,5	34,4	146,7	38,1	144,3	42,2	143,1	44,0	141,2	46,8
	10/8,2	157,0	34,7	154,9	38,3	152,1	42,4	150,8	44,2	148,6	47,0
	15/13	178,1	35,2	175,3	38,9	172,0	43,1	170,5	44,9	168,1	47,7
552	-5/-5,4	125,1	36,4	124,0	40,4	124,9	45,0	125,9	47,1	–	–
	0/-0,6	142,8	36,9	141,5	40,9	140,4	45,5	139,9	47,5	139,2	50,7
	5/3,9	160,6	37,4	158,8	41,4	156,6	46,0	155,6	47,9	154	51,1
	7/6,1	169,7	37,7	167,5	41,7	165,1	46,2	164,1	48,2	162,6	51,3
	10/8,2	178,7	37,9	175,9	41,9	173,6	46,5	172,8	48,4	171,8	51,6
	15/13	200,3	38,5	195,8	42,6	194,5	47,1	194,8	49,1	196,2	52,2
602	-5/-5,4	140,6	41,1	140,0	45,7	139,9	51,0	139,9	53,3	–	–
	0/-0,6	157,7	41,8	156,1	46,4	155,2	51,5	154,9	53,7	154,8	57,1
	5/3,9	176,1	42,4	174,2	47,0	172,2	52,0	171,4	54,1	170,2	57,5
	7/6,1	186,0	42,7	184,1	47,3	181,5	52,3	180,3	54,4	178,2	57,7
	10/8,2	196,0	43,0	194,1	47,6	190,9	52,5	189,2	54,6	186,3	57,9
	15/13	220,6	43,5	219,6	48,2	214,7	53,2	211,6	55,3	205,9	58,5
702	-5/-5,4	164,1	47,4	162,6	51,7	161,5	57,4	161,1	60,1	–	–
	0/-0,6	185,3	47,9	183,7	52,3	180,4	58,1	178,7	60,8	175,6	65,3
	5/3,9	207,1	48,5	204,7	52,9	200,7	58,8	198,6	61,5	195,1	66
	7/6,1	218,4	48,7	215,4	53,2	211,4	59,1	209,6	61,9	206,5	66,4
	10/8,2	229,7	49,0	225,9	53,5	222,2	59,4	220,7	62,2	218,6	66,7
	15/13	256,9	49,6	250,8	54,2	248,8	60,2	249,1	63,0	250,7	67,6
802	-5/-5,4	186,3	53,8	184,1	58,2	182,1	64,2	181,4	67,1	–	–
	0/-0,6	206,2	54,1	201,2	58,7	200,6	65,0	201,6	68,0	204,4	73,1
	5/3,9	228,2	54,6	222,0	59,3	221,5	65,8	222,9	68,9	226,7	74,2
	7/6,1	240,2	54,8	233,8	59,6	232,9	66,2	234,1	69,3	237,5	74,7
	10/8,2	252,4	55,1	246,1	59,9	244,6	66,6	245,3	69,8	247,8	75,1
	15/13	282,9	55,8	277,8	60,7	274,0	67,5	272,8	70,7	271,3	76,1

Wt = internal exchanger heat power (kW)

The data do not consider the pump share, required to overcome the pressure drop for the solution circulation inside the exchangers

kWe = total power input(kW)

WB = wet bulb DB = dry bulb

Acoustic configuration: compressor soundproofing (SC)

Sound levels

Size	Sound power level (dB)								Sound power level	Sound pressure level
	Octave band (Hz)									
	63	125	250	500	1000	2000	4000	8000	dB(A)	dB(A)
352	68	78	87	83	77	78	72	70	85	67
402	67	77	86	82	77	79	73	70	85	67
432	66	77	86	83	77	79	73	69	85	67
452	66	77	85	83	78	78	73	70	85	67
502	66	77	86	83	78	79	72	69	85	67
552	68	78	87	84	80	80	74	71	87	68
602	68	78	87	84	80	80	74	71	87	68
702	72	82	91	88	83	83	77	74	90	71
802	72	82	91	88	84	83	78	74	90	71

Sound levels refer to full load units, in test nominal conditions. The sound pressure level refers to 1 m. from the unit outer surface operating in open field.

Measures according to UNI EN ISO 9614-2 regulations, with respect to the EUROVENT 8/1 certification.

Data referred to the following conditions:

- internal exchanger water = 12/7°C

- outdoor air temperature 35°C

Internal exchanger pressure drops

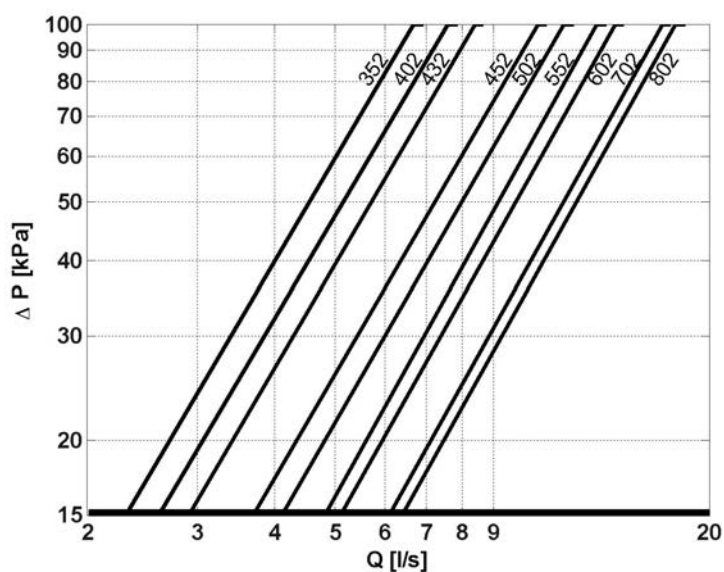

The pressure drops on the water side are calculated by considering an average water temperature at 7°C

Q = water flow rate [l/s]

DP = pressure drop [kPa]

The water flow rate must be calculated with the following formula

$$Q \text{ [l/s]} = \frac{kWf}{4,186 \times DT}$$

kWf = Cooling capacity in kW

DT = Temperature difference between inlet / outlet water



To the internal exchanger pressure drops must be added the pressure drops of the steel mesh mechanical filter that must be placed on the water input line. It is a device compulsory for the correct unit operation, and it is available as Clivet option (IFWX). If the mechanical filter is selected and installed by the Customer, it is forbidden the use of filters with the mesh pitch higher than 1,6 mm, because they can cause a bad unit operation and also its serious damaging.

Admissible water flow rates

Min. (Qmin) and max. (Qmax) water flow-rates admissibles for the correct unit operation.

Size		352	402	432	452	502	552	602	702	802
Qmin	[l/s]	2,3	2,6	2,9	3,2	3,6	3,9	4,4	4,9	5,5
Qmax	[l/s]	6,7	7,6	8,4	10,6	11,7	13,2	14,1	16,8	17,7

Acoustic configuration: extremely low noise (EN)

General technical data

Size			352	402	432	452	502	552	602	702	802
Cooling											
Cooling capacity	1	kW	81,5	94,0	102	110	117	136	150	177	195
Compressor power input	1	kW	30,7	34,7	40,0	42,3	47,7	48,7	59,1	63,1	74,3
Total power input	2	kW	32,3	36,3	41,5	43,9	49,5	51,1	61,2	66,5	76,7
Total recovery heating capacity	3	kW	110	126	139	149	162	181	205	235	264
Partial recovery heating capacity	3	kW	27,5	31,5	34,7	37,3	41,1	45,4	51,2	58,7	66,0
EER			2,52	2,59	2,45	2,51	2,37	2,67	2,45	2,67	2,55
Cooling capacity (EN14511:2013)	4	kW	81,0	93,3	101	110	117	136	150	177	195
Total power input (EN14511:2013)	4	kW	32,8	36,9	42,1	44,4	49,8	51,6	61,8	67,0	77,4
EER (EN 14511:2013)	4		2,47	2,53	2,41	2,47	2,34	2,63	2,42	2,64	2,52
SEER	10		3,49	3,65	3,55	3,75	3,62	3,74	3,52	3,92	3,63
Heating											
Heating capacity	5	kW	99,2	115	126	134	144	165	182	211	233
Compressor power input	5	kW	29,2	33,2	36,9	39,4	42,2	46,2	52,3	59,2	66,2
Total power input	2	kW	32,0	36,0	39,7	41,5	45,1	50,3	56,4	64,5	71,6
COP	5		3,10	3,20	3,18	3,23	3,20	3,27	3,22	3,28	3,25
Heating capacity (EN14511:2013)	6	kW	101	116	127	136	147	165	183	212	234
Total power input (EN14511:2013)	6	kW	32,6	36,7	40,4	42,1	45,8	51,1	57,1	65,3	72,6
COP (EN 14511:2013)	6		3,08	3,16	3,14	3,23	3,20	3,24	3,21	3,25	3,23
SCOP - AVERAGE Climate - W35	10		3,40	3,41	3,48	3,54	3,54	3,48	3,49	3,44	3,40
Compressor											
Type of compressors			SCROLL	SCROLL	SCROLL	SCROLL	SCROLL	SCROLL	SCROLL	SCROLL	SCROLL
No. of compressors		Nr	2	2	2	2	2	2	2	2	2
Rated power (C1)		HP	35	40	43	45	50	55	60	70	80
Std Capacity control steps		Nr	3	3	3	3	3	3	2	3	2
Oil charge (C1)		l	8,00	10,0	12,0	10,0	11,0	13,0	13,0	13,0	13,0
Refrigerant charge (C1)	7	kg	39	43	48	50	54	58	61	67	72
Refrigeration circuits		Nr	1	1	1	1	1	1	1	1	1
Internal exchanger											
Type of internal exchanger	8		PHE	PHE	PHE	PHE	PHE	PHE	PHE	PHE	PHE
Water flow rate (Utility Side)	1	l/s	3,90	4,50	4,90	5,30	5,60	6,50	7,20	8,50	9,30
Internal exchanger pressure drops	1	kPa	36	37	36	26	26	26	27	26	29
Water content		l	4,80	5,50	6,10	8,00	8,90	10,1	11,1	14,2	15,8
External exchanger											
Quantity		Nr	2	2	2	2	2	2	2	2	2
Front surface		m ²	6,30	6,30	6,30	6,30	6,30	8,90	8,90	11,6	11,6
External Section Fans											
Type of fans	9		AX	AX	AX	AX	AX	AX	AX	AX	AX
Number of fans		Nr	2	2	2	2	2	3	3	4	4
Standard airflow		l/s	12497	12281	12281	12217	12105	18255	18255	24267	24267
CONNECTIONS											
Water connections			2" 1/2	2" 1/2	2" 1/2	2" 1/2	2" 1/2	2" 1/2	2" 1/2	2" 1/2	2" 1/2
Power supply											
Standard power supply		V	400/3/50	400/3/50	400/3/50	400/3/50	400/3/50	400/3/50	400/3/50	400/3/50	400/3/50
STANDARD UNIT WEIGHTS											
Shipping weight		kg	910	970	1053	1093	1117	1315	1330	1535	1550
Operating weight		kg	915	975	1059	1101	1126	1326	1341	1549	1564

The Product is compliant with the Erp (Energy Related Products) European Directive. It includes the Commission delegated Regulation (EU) No 811/2013 (rate heat output < 70 kW at specified reference conditions) and the Commission delegated Regulation (EU) No 813/2013 (rated heat output < 400 kW at specified reference conditions).

*Contains fluorinated greenhouse gases (GWP 2087,5)

1. Data referred to the following conditions: internal exchanger water = 12/7 °C external exchanger inlet air 35°C
2. The Total Power Input value does not take into account the part related to the pumps and required to overcome the pressure drops for the circulation of the solution inside the exchangers
3. Recovery exchanger water=40/45°C
4. Data calculated in compliance with Standard EN 14511:2013 referred to the following conditions: - Internal exchanger water temperature = 12/7°C - external exchanger entering air temperature = 35°C
5. Data referred to the following conditions: Internal exchanger water temperature = 40/45 °C. External exchanger air temperature 7 D.B. /6.1°C W.B.
6. Data calculated in compliance with Standard EN 14511:2013 referred to the following conditions: Internal exchanger water temperature = 40/45 °C. external exchanger air temperature 7 D.B. /6°C W.B.
7. Indicative values for standard units with possible +/-10% variation. The actual data are indicated on the label of the unit.
8. PHE = plates
9. AX = axial fan
10. Data calculated according to the EN 14825:2016 Regulation

Acoustic configuration: extremely low noise (EN)

Electrical data

Size		352	402	432	452	502	552	602	702	802
F.L.A. - Full load current at max admissible conditions										
F.L.A. - Total	A	76,1	84,5	90,1	98,8	104,5	117,0	131,4	150,0	164,5
F.L.I. - Full load power input at max admissible conditions										
F.L.I. - Total	kW	44,2	49,0	54,4	57,8	63,2	70,2	79,0	91,8	102,4
M.I.C. Maximum inrush current										
M.I.C. - Value	A	264,6	311,6	317,2	349,6	355,2	367,7	382,1	470,2	484,7

Voltage unbalance: max 2 %
power supply: 400/3/50 Hz +/- 6%

Power supply: 400/3/50 Hz +/- 10%
Electrical data refer to standard units; according to the installed accessories, the data can suffer some variations.

Operating range (Cooling)

Size			352	402	432	452	502	552	602	702	802
External exchanger											
Max entering air temperature	1	°C	44	44	43	43	41	44	42	45	44
Max entering air temperature	2	°C	45	46	45	45	44	46	45	46	46
Max entering air temperature	3	°C	50	50	50	50	50	50	50	50	50
Min. entering air temperature	4	°C	-10	-10	-10	-10	-10	-10	-10	-10	-10
Min. entering air temperature	5	°C	-7,0	-7,0	-7,0	-7,0	-7,0	-7,0	-7,0	-7,0	-7,0
Min. entering air temperature	6	°C	-2,0	-2,0	-2,0	-2,0	-2,0	-2,0	-2,0	-2,0	-2,0
Min. entering air temperature	7	°C	11	11	11	11	11	11	11	11	11
Internal exchanger											
Max inlet water temperature		°C	24	24	24	24	24	24	24	24	24
Min. outlet water temperature	8	°C	5,0	5,0	5,0	5,0	5,0	5,0	5,0	5,0	5,0
Min. outlet water temperature	9	°C	-8,0	-8,0	-8,0	-8,0	-8,0	-8,0	-8,0	-8,0	-8,0

Data referred to the following conditions:

- internal exchanger water = 12/7°C
- difference between inlet / outlet water temperature = 5°C

Caution: Air conditions which are at rest are defined as the absence of air flows to the unit. Weak winds can induce air flows through the exchanger which can cause a reduction in the operating range (see limits with air speed at 0,5 m/s & 1 m/s).

Note: In any case, the unit should never be exposed to or operated, transported and/or stored at temperatures below -10°C.

ATTENTION: IN CASE OF PREDOMINANT WINDS, WINDBREAK BARRIERS ARE NECESSARY.

- | | |
|---|---|
| <ol style="list-style-type: none"> 1. Max inlet temperature - unit at full load 2. Inlet air Max Temperature - unit at full load with standard limit device. For the sound levels under these operating conditions, please refer to the data for the SC version 3. Max inlet air temperature - capacity-controlled unit with standard limit device 4. Min inlet air temperature - unit at full load and outdoor air at rest | <ol style="list-style-type: none"> 5. Min inlet air temperature - unit at part load and outdoor air at rest 6. Min inlet air temperature - unit at partial load and air speed of 0.5 m/s. 7. Min inlet air temperature - unit at partial load and air speed of 1 m/s. 8. Standard unit. external exchanger entering air 35°C 9. B = Low temperature. external exchanger inlet air 35°C. Fluid treated with 40% ethylene glycol |
|---|---|

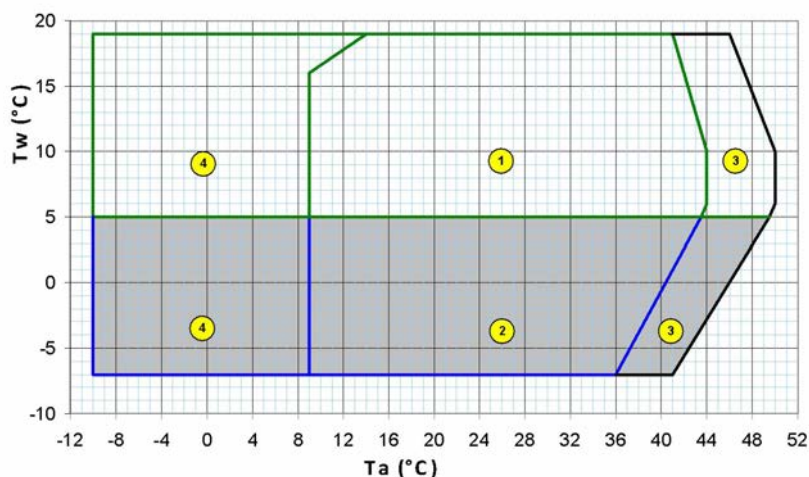

Ta = Entering air temperature to the external exchanger

Tw [°C] = Exchanger outlet water temperature

Graph informed to size 352, for more details for each size, refer to the table below.

1. Standard Version
2. Low temperature version "B" (fluid with ethylene glycol)
3. Capacity-controlled unit (automatic capacity control)
4. Full-load unit with air flow module

Acoustic configuration: extremely low noise (EN)

Operating range (Heating)

Size			352	402	432	452	502	552	602	702	802
External exchanger											
Max entering air temperature (WB)	1	°C	25	25	25	25	25	25	25	25	25
Min inlet air temperature (D.B.)		°C	-6,0	-6,0	-6,0	-6,0	-6,0	-6,0	-6,0	-6,0	-6,0
Min inlet air temperature (D.B.)	2	°C	-10	-10	-10	-10	-10	-10	-10	-10	-10
Internal exchanger											
Min. outlet water temperature		°C	25	25	25	25	25	25	25	25	25
Max water outlet temperature		°C	53	53	53	53	53	53	53	53	53

Data referred to the following conditions:

- internal exchanger water = 12/7°C
- difference between inlet / outlet water temperature = 5°C

Caution: Air conditions which are at rest are defined as the absence of air flows to the unit. Weak winds can induce air flows through the exchanger which can cause a reduction in the operating range (see limits with air speed at 0,5 m/s & 1 m/s).

Note: In any case, the unit should never be exposed to or operated, transported and/or stored at temperatures below -10°C.

ATTENTION: IN CASE OF PREDOMINANT WINDS, WINDBREAK BARRIERS ARE NECESSARY.

1. Unit at full load. internal exchanger water = 40/45 °C

2. Limit with option OHE

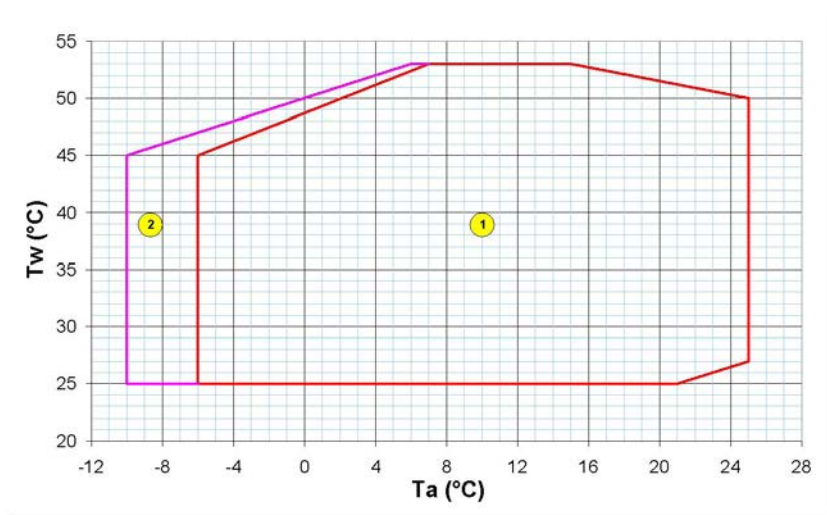

Twu [°C] = Exchanger water outlet temperature

Ta [°C] = Air temperature dry bulb

1. Standard Version
2. Operating with "OHE" functioning limits extension kit

Acoustic configuration: extremely low noise (EN)

Performances in Cooling

Size	To (°C)	Entering external exchanger air temperature (°C)													
		25		30		32		35		38		41		43	
		kWf	kWe	kWf	kWe	kWf	kWe	kWf	kWe	kWf	kWe	kWf	kWe	kWf	kWe
352	5	86,8	24,9	81,8	27,4	79,8	28,4	76,6	30,0	73,4	31,8	70,0	33,6	67,7	34,8
	6	89,5	25,2	84,3	27,7	82,2	28,7	79,0	30,4	75,9	32,1	72,7	33,8	70,6	35,0
	7	92,3	25,5	86,8	28,0	84,6	29,1	81,5	30,7	78,4	32,3	75,4	34,0	73,5	35,2
	8	95,1	25,7	89,4	28,3	87,2	29,4	84,0	31,0	81,0	32,6	78,2	34,3	76,3	35,4
	9	98,0	26,0	92,0	28,7	89,8	29,7	86,6	31,3	83,7	32,9	80,9	34,5	79,2	35,6
	10	101	26,3	94,7	29,0	92,5	30,0	89,3	31,6	86,4	33,2	83,7	34,8	82,0	35,9
402	5	99,9	28,3	94,3	31,0	92,0	32,2	88,5	34,0	84,9	35,8	81,2	37,8	78,7	39,1
	6	103	28,6	97,1	31,4	94,7	32,5	91,2	34,3	87,7	36,1	84,2	38,0	81,9	39,3
	7	106	28,9	99,9	31,7	97,5	32,9	93,9	34,7	90,5	36,4	87,2	38,3	85,0	39,5
	8	109	29,2	103	32,1	100	33,2	96,7	35,0	93,3	36,7	90,1	38,5	88,1	39,7
	9	113	29,5	106	32,4	103	33,6	99,6	35,3	96,2	37,0	93,0	38,8	91,1	39,9
	10	116	29,8	109	32,7	106	33,9	102	35,6	99,1	37,3	95,9	39,0	94,0	40,2
432	5	109	32,8	102	35,8	99,6	37,2	95,1	39,5	90,1	42,0	84,6	44,9	80,7	46,9
	6	112	33,2	105	36,3	103	37,6	98,4	39,7	94,0	41,9	89,5	44,3	86,4	45,9
	7	116	33,5	108	36,8	106	38,1	102	40,0	97,8	41,9	94,1	43,8	91,7	45,1
	8	119	33,9	111	37,3	109	38,5	105	40,3	101	42,0	98,4	43,5	96,6	44,5
	9	123	34,3	115	37,7	112	39,0	108	40,6	105	42,1	102	43,4	101	44,1
	10	126	34,7	118	38,2	115	39,4	111	41,0	109	42,3	106	43,4	105	43,9
452	5	116	34,9	110	38,1	107	39,5	103	41,6	99	43,8	94,7	46,1	91,7	47,6
	6	120	35,3	113	38,5	111	39,8	107	41,9	102	44,1	97,8	46,4	94,8	48,0
	7	124	35,6	117	38,8	114	40,2	110	42,3	106	44,4	101	46,7	97,9	48,3
	8	127	36,0	121	39,2	118	40,5	113	42,6	109	44,8	104	47,1	101	48,7
	9	131	36,4	124	39,5	121	40,8	117	42,9	112	45,1	107	47,5	104	49,1
	10	135	36,8	128	39,9	125	41,2	120	43,3	116	45,5	111	47,8	107	49,5
502	5	125	39,4	118	43,0	115	44,5	110	46,8	106	49,2	101	51,7	98,1	53,4
	6	129	39,8	122	43,4	119	44,9	114	47,3	109	49,6	104	52,1	101	53,8
	7	133	40,2	125	43,9	122	45,4	117	47,7	113	50,1	108	52,5	105	54,2
	8	137	40,7	129	44,3	126	45,8	121	48,1	116	50,5	111	53,0	108	54,6
	9	141	41,2	133	44,8	130	46,3	125	48,6	120	51,0	115	53,4	111	55,1
	10	145	41,7	137	45,3	133	46,8	128	49,1	123	51,4	118	53,9	115	55,5
552	5	145	40,1	136	43,9	133	45,5	128	48,0	123	50,6	118	53,3	114	55,1
	6	149	40,6	141	44,3	137	45,9	132	48,4	127	51,0	121	53,7	118	55,6
	7	153	41,1	145	44,7	142	46,3	136	48,7	131	51,3	125	54,1	121	56,0
	8	158	41,6	149	45,1	146	46,7	140	49,1	135	51,7	129	54,5	125	56,4
	9	162	42,0	154	45,5	150	47,1	145	49,5	139	52,1	132	54,9	128	56,8
	10	167	42,5	158	46,0	155	47,5	149	49,9	143	52,5	136	55,2	132	57,2
602	5	157	49,0	149	53,5	145	55,3	140	58,1	135	60,9	129	63,8	126	65,8
	6	163	49,6	154	54,0	150	55,8	145	58,6	140	61,4	134	64,2	131	66,2
	7	168	50,1	159	54,5	156	56,3	150	59,1	144	61,8	139	64,7	135	66,6
	8	174	50,7	164	55,0	161	56,8	155	59,5	149	62,3	143	65,1	140	67,0
	9	179	51,2	170	55,6	166	57,3	160	60,0	154	62,8	148	65,5	144	67,4
	10	185	51,7	175	56,1	170	57,8	164	60,5	158	63,2	152	65,9	148	67,7
702	5	187	51,9	177	56,8	173	58,8	167	62,1	160	65,5	154	69,1	150	71,7
	6	193	52,5	183	57,3	178	59,3	172	62,6	166	66,0	159	69,7	155	72,2
	7	199	53,1	188	57,8	184	59,9	177	63,1	171	66,5	164	70,2	159	72,7
	8	205	53,7	194	58,3	189	60,4	183	63,6	176	67,1	169	70,7	164	73,3
	9	211	54,2	199	58,9	195	60,9	188	64,1	181	67,6	174	71,3	169	73,8
	10	217	54,8	205	59,4	200	61,4	193	64,6	186	68,1	179	71,8	174	74,4
802	5	205	61,0	194	66,5	190	68,9	183	72,7	175	76,7	168	81,0	163	84,0
	6	213	61,6	201	67,2	196	69,6	189	73,5	182	77,6	174	82,0	169	85,0
	7	220	62,2	208	67,8	203	70,3	195	74,2	188	78,4	181	82,9	176	86,0
	8	227	62,8	214	68,5	209	71,0	202	75,0	194	79,2	187	83,8	181	86,9
	9	234	63,4	221	69,2	216	71,7	208	75,7	200	80,0	192	84,6	187	87,8
	10	240	64,0	227	69,8	222	72,4	214	76,4	206	80,7	198	85,4	193	88,6

kWf = Cooling capacity in kW

The data do not consider the pump share, required to overcome the pressure drop for the solution circulation inside the exchangers

kWe = Compressor power input in kW

To = Leaving water temperature on hydraulic circuit, cooling side (°C), load input/output = 5°C

Acoustic configuration: extremely low noise (EN)

Performance in Heating

Size	Ta (°C) DB/WB	External exchanger water inlet / outlet temperature (°C)									
		30 / 35		35 / 40		40 / 45		42 / 47		45 / 50	
		kWt	kWe	kWt	kWe	kWt	kWe	kWt	kWe	kWt	kWe
352	-5/-5,4	74,5	22,5	75,1	25,1	75,2	28,2	75,2	29,5	–	–
	0/-0,6	86,1	23,0	85,1	25,6	84,4	28,6	84,1	29,9	83,8	31,9
	5/3,9	97,9	23,5	95,7	26,0	94,0	29,0	93,5	30,2	93,0	32,2
	7/6,1	104	23,7	101,2	26,3	99,2	29,2	98,5	30,5	97,7	32,4
	10/8,2	110	23,9	106,8	26,5	104,3	29,4	103,5	30,7	102,4	32,7
	15/13	124,3	24,4	120,3	27,1	116,8	30,0	115,6	31,3	113,9	33,2
402	-5/-5,4	88,7	25,9	88,5	28,7	88,1	32,1	–	–	–	–
	0/-0,6	99,6	26,2	100,1	29,1	98,9	32,5	97,9	34,1	95,8	36,5
	5/3,9	112,1	26,5	111,6	29,5	109,7	33,0	108,6	34,5	106,6	37,0
	7/6,1	118,9	26,7	117,3	29,7	115,3	33,2	114,4	34,8	112,9	37,3
	10/8,2	126,0	26,9	122,9	29,9	120,8	33,4	120,2	35,0	119,7	37,5
	15/13	143,7	27,5	136,1	30,4	134,0	33,9	134,7	35,5	137,6	38,0
432	-5/-5,4	97,6	28,7	97,1	32,0	97,2	35,8	97,3	37,5	–	–
	0/-0,6	109,5	29,1	109,9	32,4	107,7	36,2	106	37,8	102,7	40,4
	5/3,9	122,4	29,6	123,2	32,9	119,6	36,6	116,9	38,2	111,7	40,8
	7/6,1	129,4	29,8	130,0	33,1	126,1	36,9	123,2	38,5	117,6	41,0
	10/8,2	136,5	30,1	136,8	33,4	132,7	37,1	129,8	38,7	124,1	41,3
	15/13	154,2	30,7	153,3	34,0	149,4	37,8	147	39,4	142,4	42,0
452	-5/-5,4	102,6	31,0	102,6	34,4	102,6	38,3	102,5	40,0	–	–
	0/-0,6	114,3	31,4	115,6	34,8	113,9	38,7	112,3	40,5	109,2	43,2
	5/3,9	127,9	31,8	129,4	35,2	126,8	39,2	124,7	40,9	120,3	43,6
	7/6,1	135,5	32,0	136,7	35,4	134,0	39,4	131,9	41,1	127,5	43,8
	10/8,2	143,3	32,1	144,0	35,6	141,4	39,6	139,4	41,3	135,4	44,1
	15/13	163,2	32,6	162,0	36,1	160,1	40,1	159,1	41,9	157,4	44,6
502	-5/-5,4	109,8	33,1	109,7	36,8	110,6	41,1	111,2	43,0	–	–
	0/-0,6	124,4	33,7	123,5	37,3	122,7	41,5	122,5	43,4	122,1	46,3
	5/3,9	140,1	34,2	138,6	37,8	136,6	42	135,7	43,8	134,2	46,6
	7/6,1	148,5	34,4	146,7	38,1	144,3	42,2	143,1	44	141,2	46,8
	10/8,2	157,0	34,7	154,9	38,3	152,1	42,5	150,8	44,2	148,6	47
	15/13	178,1	35,2	175,3	39,0	172,0	43,1	170,5	44,9	168,1	47,6
552	-5/-5,4	125,1	36,4	124,0	40,4	124,9	45,0	125,9	47,1	–	–
	0/-0,6	142,8	36,9	141,5	40,9	140,4	45,5	139,9	47,5	139,2	50,7
	5/3,9	160,6	37,4	158,8	41,4	156,6	46,0	155,6	47,9	153,9	51,1
	7/6,1	169,7	37,7	167,5	41,7	165,1	46,2	164,1	48,2	162,6	51,3
	10/8,2	178,7	37,9	175,9	41,9	173,6	46,5	172,8	48,4	171,8	51,5
	15/13	200,3	38,5	195,9	42,6	194,5	47,1	194,8	49,1	196,2	52,2
602	-5/-5,4	140,6	41,1	140,1	45,7	139,9	51,0	139,9	53,3	–	–
	0/-0,6	157,7	41,8	156,1	46,4	155,2	51,5	154,9	53,7	154,8	57,1
	5/3,9	176,1	42,4	174,2	47,0	172,2	52,0	171,4	54,1	170,2	57,5
	7/6,1	186,0	42,7	184,1	47,3	181,5	52,3	180,3	54,4	178,2	57,7
	10/8,2	196,0	43,0	194,1	47,6	190,9	52,5	189,2	54,6	186,3	57,9
	15/13	220,6	43,5	219,6	48,2	214,6	53,2	211,6	55,3	205,9	58,5
702	-5/-5,4	164,1	47,4	162,6	51,7	161,5	57,4	161,1	60,1	–	–
	0/-0,6	185,3	47,9	183,7	52,3	180,4	58,1	178,7	60,8	175,6	65,3
	5/3,9	207,1	48,5	204,7	52,9	200,7	58,8	198,6	61,5	195,1	66
	7/6,1	218,4	48,7	215,4	53,2	211,4	59,1	209,6	61,9	206,5	66,4
	10/8,2	229,7	49,0	225,9	53,5	222,2	59,4	220,8	62,2	218,6	66,7
	15/13	256,9	49,6	250,8	54,2	248,8	60,2	249,1	63,0	250,7	67,6
802	-5/-5,4	186,3	53,8	184,1	58,2	182,1	64,2	181,4	67,1	–	–
	0/-0,6	206,2	54,1	201,2	58,7	200,6	65,0	201,6	68,0	204,4	73,1
	5/3,9	228,2	54,6	222,0	59,3	221,5	65,8	222,9	68,9	226,7	74,2
	7/6,1	240,2	54,8	233,8	59,6	232,9	66,2	234,1	69,4	237,5	74,7
	10/8,2	252,4	55,1	246,1	59,9	244,6	66,6	245,3	69,8	247,8	75,1
	15/13	282,9	55,8	277,8	60,7	274,0	67,5	272,8	70,7	271,4	76,1

kWt = internal exchanger heat power (kW)

The data do not consider the pump share, required to overcome the pressure drop for the solution circulation inside the exchangers

kWe = total power input(kW)

WB = wet bulb DB = dry bulb

Acoustic configuration: extremely low noise (EN)

Sound levels

Size	Sound power level (dB)								Sound power level	Sound pressure level
	Octave band (Hz)									
	63	125	250	500	1000	2000	4000	8000	dB(A)	dB(A)
352	63	79	81	76	71	75	67	65	80	62
402	62	78	81	75	73	76	68	67	81	63
432	62	78	83	77	74	77	69	66	82	64
452	63	79	81	77	75	76	69	67	82	64
502	62	78	83	77	75	77	69	65	82	64
552	64	80	84	78	77	78	71	68	84	65
602	64	80	84	79	77	78	71	68	84	65
702	66	81	85	80	78	79	72	69	85	66
802	66	82	85	81	79	80	72	69	85	66

Sound levels refer to full load units, in test nominal conditions. The sound pressure level refers to 1 m. from the unit outer surface operating in open field. Measures according to UNI EN ISO 9614-2 regulations, with respect to the EUROVENT 8/1 certification.

Data referred to the following conditions:

- internal exchanger water = 12/7°C
- outdoor air temperature 35°C

The sound levels EN version is valid within the operating range relative to these acoustic versions; make reference to the noise data relative to SC version for higher outdoor air temperatures and in any case included within the operation limits of SC version.

Internal exchanger pressure drops

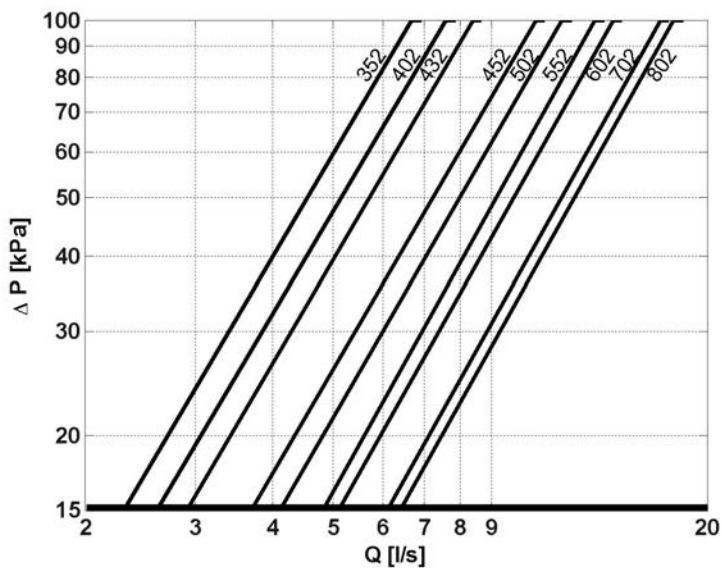

The pressure drops on the water side are calculated by considering an average water temperature at 7°C

Q = water flow rate [l/s]
DP = pressure drop [kPa]

The water flow rate must be calculated with the following formula

$$Q \text{ [l/s]} = \frac{kWf}{4,186 \times DT}$$

kWf = Cooling capacity in kW
DT = Temperature difference between inlet / outlet water



To the internal exchanger pressure drops must be added the pressure drops of the steel mesh mechanical filter that must be placed on the water input line. It is a device compulsory for the correct unit operation, and it is available as Clivet option (IFWX). If the mechanical filter is selected and installed by the Customer, it is forbidden the use of filters with the mesh pitch higher than 1,6 mm, because they can cause a bad unit operation and also its serious damaging.

Admissible water flow rates

Min. (Qmin) and max. (Qmax) water flow-rates admissible for the correct unit operation.

Size		352	402	432	452	502	552	602	702	802
Qmin	[l/s]	2,3	2,6	2,9	3,2	3,6	3,9	4,4	4,9	5,5
Qmax	[l/s]	6,7	7,6	8,4	10,6	11,7	13,2	14,1	16,8	17,7

Configurations

Consult the special prospective reported in the final section to check for compatibility between different options.

B - Low water temperature

Configuration also known as “Brine”. Enables an “unfreezable” solution to be cooled (for example, water and ethylene glycol in suitable quantities) up to a temperature of between +4°C and -8°C.

It includes:

- suitable exchangers with extra-thick closed-cell insulation
- electronic expansion valve, functional calibration and safety devices suitable for particular uses.

During the selection phase it is necessary to indicate the required operating type, the unit will be optimised on the basis of this: - Unit with single operating set-point (only at low temperature) - Unit with double operating set-point

The unit in this configuration has a different operation range, indicated in the operating range section.

In low temperature operation, some staging steps could not be available.

The glycol concentration must be chosen based on the minimum temperature the water can reach. The presence of glycol influences pressure drops on the water side and the unit’s output as indicated in the table reporting the “correction factors for use with glycol”.

D - Partial energy recovery

A configuration which enables the production of hot water free-of-charge while operating in the cooling mode, thanks to the partial recovery of condensation heat that would otherwise be disposed of into the external heat source.

This option is also known as “desuperheater”. It is made up of a Inox 316 stainless steel brazed plate heat exchangers, suitable for recovering a part of the capacity dispersed by the unit (the dispersed heating capacity is equal to the sum of the cooling capacity and the electrical input capacity of the compressors).

The partial recovery device is considered to be operating when it is powered by the water flow which is to be heated. This condition improves the unit performance, since it reduces the condensation temperature: in nominal conditions the cooling capacity increases indicatively by 3.2% and the power input of the compressors is reduced by 3.6%.

When the temperature of the water to be heated is particularly low, it is opportune to insert a flow regulation valve in the hydraulic circuit, to maintain the recovery output temperature at higher than 35°C and thus avoid refrigerant condensation in the partial energy recovery device.

The power delivered by the partial recovery is 20% of the thermal power dissipation (cooling + electrical power absorbed by the compressors)

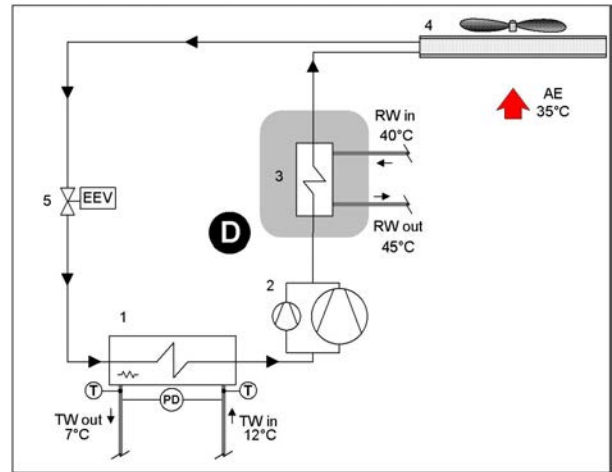

D - Partial recovery device

- 1 - Internal exchanger
- 2 - Compressors
- 3 - Recovery exchanger
- 4 - External exchanger
- 5 - Expansion electronic valve
- TW in chilled water inlet

- TW out chilled water outlet
- RW in - Recovery water inlet
- RW out - Recovery water outlet
- T - Temperature probe
- PD - Differential pressure switch
- AE Outdoor air

Pressure drops of partial energy recovery exchanger

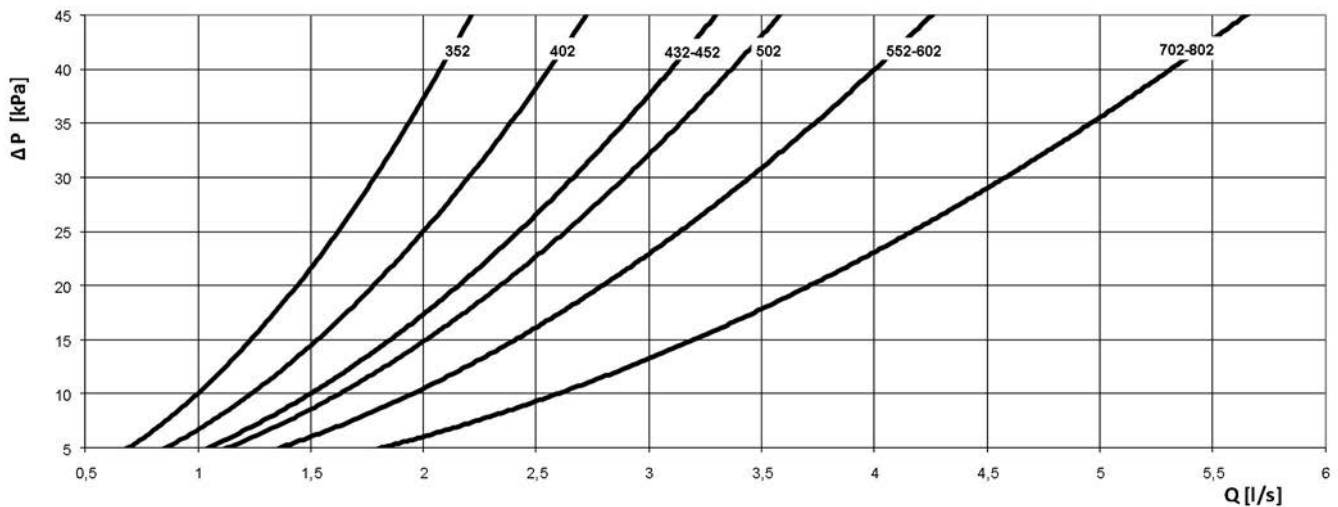

Q = Water flow rate [l/s]
DP = Pressure drops [kPa]

R - Total energy recovery

A configuration which enables the production of hot water free-of-charge while operating in the cooling mode, thanks to the total recovery of condensation heat that would otherwise be disposed of into the external heat source. This solution increases the overall efficiency of the system in all cases where a high-level of hot water production is required. It is made up of a brazed plate heat exchanger made of 316 stainless steel, suitable for recovering all the unit heat capacity (equal to the sum of the cooling capacity and the electrical input capacity of the compressors), from the on-off type solenoid valve, from the supply and return temperature sensors in the hot water circuit and the related two-step integrated control logic.

Hot water availability is always subordinate to the production of chilled water.

See the following example:

1. cooling capacity request = 100% / Heating capacity request = 0% >Production only of cooling capacity;
2. cooling capacity request = 100% / Heating capacity request = 0% >Production of cooling and heating capacity by recovery;
3. cooling capacity request = 50% / Heating capacity request = 100% >Production of cooling and heating capacity by recovery, equal to the 50% of the requested heating capacity.

To prevent constant switching in the unit's refrigeration circuit, it is necessary to install a storage tank with an adequate capacity in the system's hot water circuit.

In the absence of hot water circulation in the recovery exchanger, the maximum inlet air temperature is reduced by approximately 2°C compared with the unit without "Total Energy Recovery" mode.

TOTAL OPERATING ENERGY RECOVERY

When hot water is requested, the condensing coil is deactivated. Condensation takes place wholly within the recovery circuit.

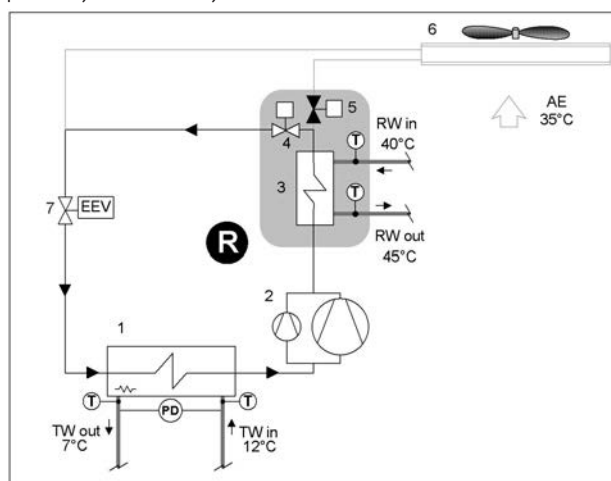

- | | |
|---------------------------------------|-----------------------------------|
| R - Total recovery device | 6 - External exchanger |
| 1 - Internal exchanger | 7 - Expansion electronic valve |
| 2 - Compressors | |
| 3 - Recovery exchanger | T - Temperature probe |
| 4 - Total recovery enabling valve | PD - Differential pressure switch |
| 5 - External exchanger enabling valve | AE Outdoor air |

TOTAL NON-OPERATING ENERGY RECOVERY

When the recovery set-point has been satisfied, the condensing coil is reactivated. In this condition, the total recovery circuit operates as a Partial recovery circuit (Desuperheater).

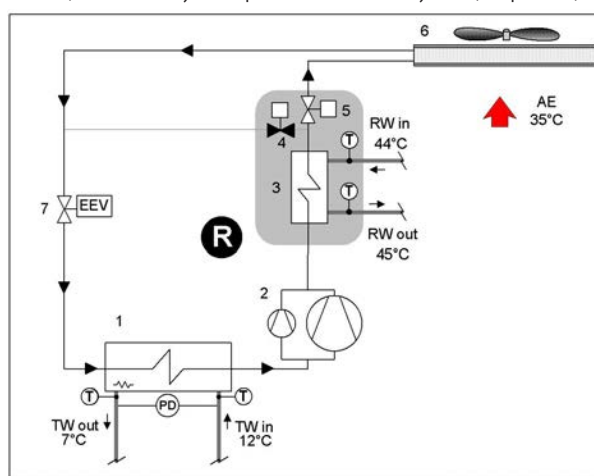

- | |
|--------------------------------|
| TW in chilled water inlet |
| TW out chilled water outlet |
| RW in - Recovery water inlet |
| RW out - Recovery water outlet |

Pressure drops of the total energy recovery exchanger

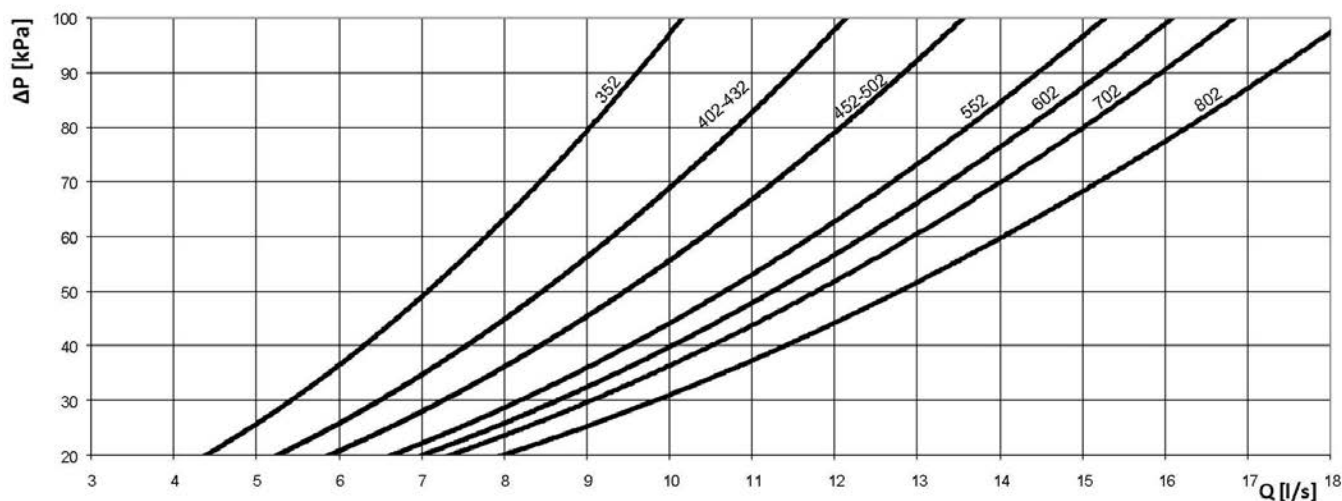

Q = Water flow rate [l/s]
DP = Pressure drops [kPa]

Accessories - Hydronic assembly

1PUS - Standard pump

Option supplied on the unit. Centrifugal electric pump with pump body and impeller made with AISI 304 stainless steel. Mechanical seal by means of components made of ceramics, carbon and EPDM elastomers. Three-phase electric motor with IP55 protection rating. Complete with a thermoformed insulating casing, quick couplings with an insulated casing, a check valve, a safety valve, pressure gauges, a system safety pressure switch, stainless steel, antifreeze, intake and supply, immersion-type heaters.

The various models which are available can be differentiated by the system available pressure.

1PU1SB - Standard pump with standby pump

Option supplied on the unit. Two centrifugal electric pumps, one of which in stand-by, with AISI 304 stainless body and impeller. Mechanical seal by means of components made of ceramics, carbon and EPDM elastomers. Three-phase electric motor with IP55 protection rating. Complete with a thermoformed insulating casing, quick couplings with an insulated casing, a check valve, a safety valve, pressure gauges, a system safety pressure switch, stainless steel, antifreeze, intake and supply, immersion-type heaters. The microprocessor control balances the hours of operation and, in the event of malfunctions, it indicates the failure and automatically activates the standby pump.

The various models which are available can be differentiated by the system available pressure.



The 1PUS and 1PU1SB options are supplied as standard with the hydraulic connection kit on the system's return line (the Customer is responsible for installations outside the unit). The kit consists of: -no. 1 cast-iron shut-off butterfly valve equipped with throttle drive and mechanical calibration stop - no. 1 quick coupling

A300/A500 - 300/500 litres storage tank

Option supplied built-in the unit. Steel storage tank complete with double layer covering with closed-cell insulation, stainless steel anti-freeze immersion resistance, bleed valve, draw off cock, cast-iron shut-off butterfly valve with quick connections and activation lever with a mechanical calibration lock at the evaporator output, quick connections with insulated casing.

The various available models can be differentiated by capacity.



The A300 and A550 options are supplied as standard with the hydraulic connection kit on the system's return line (the Customer is responsible for installations outside the unit). The kit consists of: -no. 1 cast-iron shut-off butterfly valve equipped with throttle drive and mechanical calibration stop - no. 1 quick coupling

STANDARD PUMP / STANDARD PUMP WITH STANDBY PUMP

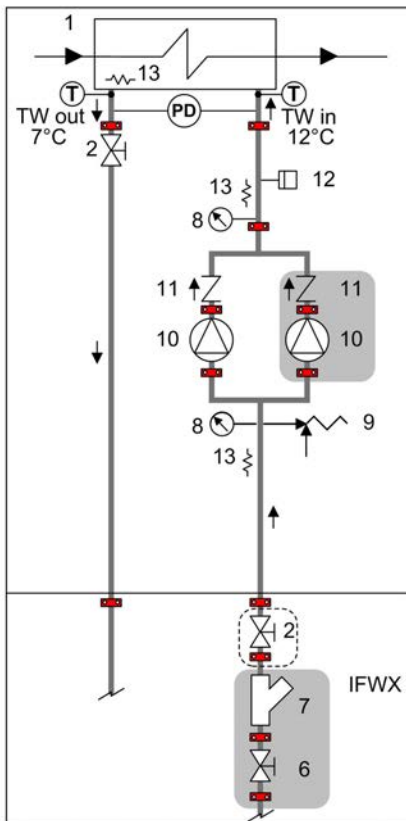

STORAGE TANK

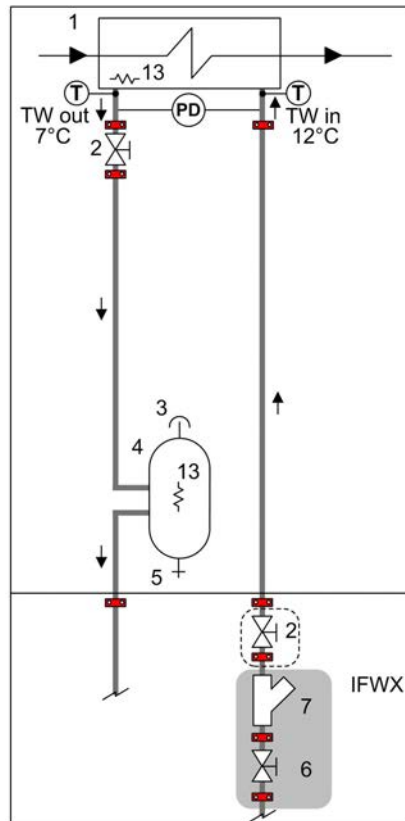

STANDARD PUMP / WITH RESERVE PUMP AND STORAGE TANK

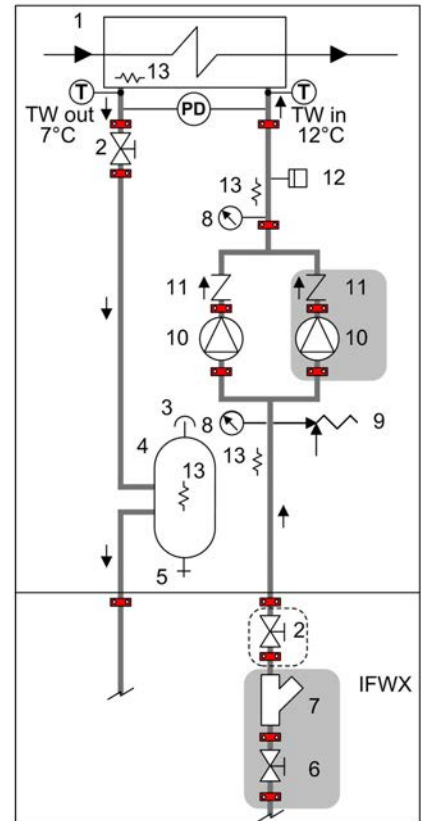

- 1 - Internal exchanger
- 2 - Cutoff valve
- 3 - Purge valve
- 4 - Storage tank with antifreeze heater
- 5 - Draw off cock
- 6 - Cutoff valve with quick joints

- 7 - Steel mesh strainer water side
- 8 - Manometer
- 9 - Safety valve (6 Bar)
- 10 - Packaged electric pump with high efficiency impeller
- 11 - Non return valve
- 12 - System safety pressure switch (prevents the pumps from operating if no water is present)
- 13 - Antifreeze heater

- TW in chilled water inlet
- TW out chilled water outlet
- IFWX = Steel mesh strainer water side
- T - Temperature probe
- PD - Differential pressure switch

Water connection kit supplied as standard

The grey area indicates further optional components.

1PUS / 1PU1SB option performances

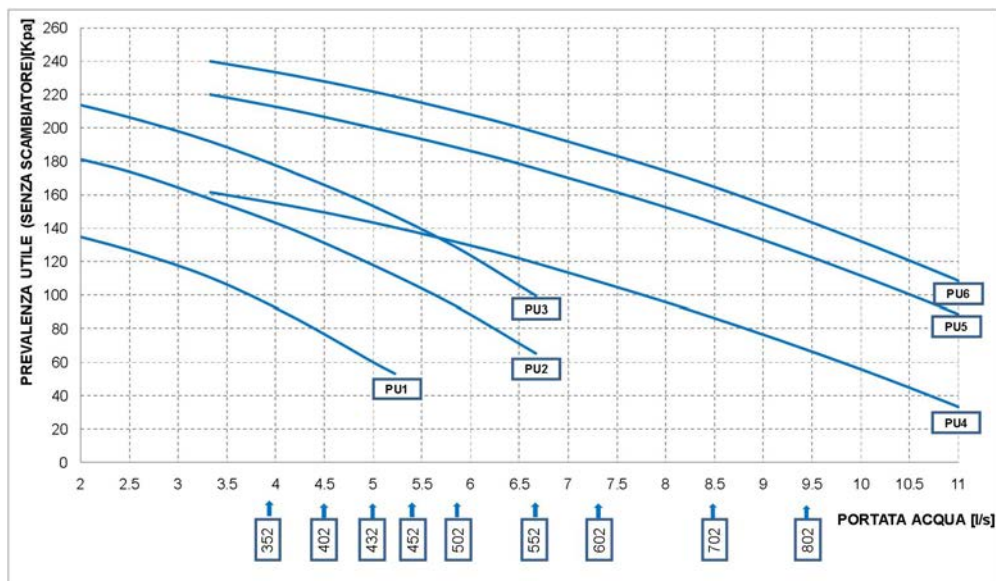

Q = Water flow rate [l/s]
 DP = Pressure drops [kPa]



Caution: to obtain the available pressure values, you need to subtract the following from the head values represented in these diagrams: –Evaporator pressure drops –IFVX accessory –Steel mesh filter on the water side (where applicable)

Single Pump Technical Specifications

PUMP	Rated power [kW]	Nominal power [A]
PU1	1.4	2.6
PU2	1.4	2.6
PU3	1.8	3.2
PU4	1.8	3.4
PU5	2.9	4.8
PU6	3.3	5.6

A300RPS/A500RPS - 300/500 litres storage tank with primary circuit built-in

Option supplied built-in. Simplifies system design and manufacture. Available only when the '1PUS - Standard pump' or '1PU1SB - Standard pump with standby pump' option is present, this accessory includes the components provided for the A300 / A450 / A500 / A550 option, as well as:

- primary circuit, already set up and tested inside the unit;
- cast-iron butterfly shut-off valve, with quick connections and activating handle and mechanical calibration lock in evaporator outlet and on the pump supply.

 A300RPS and A500RPS options are available only with the "Low head pump" option.

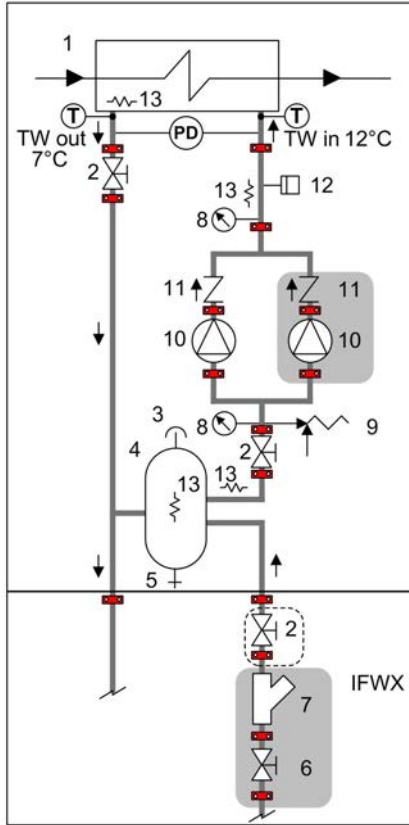

- 1 - Internal exchanger
- 2 - Cutoff valve
- 3 - Purge valve
- 4 - Storage tank with antifreeze heater
- 5 - Draw off cock
- 6 - Cutoff valve with quick joints
- 7 - Steel mesh strainer water side
- 8 - Manometer
- 9 - Safety valve (6 Bar)
- 10 - Packaged electric pump with high efficiency impeller
- 11 - Non return valve
- 12 - System safety pressure switch (prevents the pumps from operating if no water is present)
- 13 - Antifreeze heater

IFWX = Steel mesh strainer water side

TW in chilled water inlet
TW out chilled water outlet

T - Temperature probe
PD - Differential pressure switch

The grey area indicates further optional components.

 If the water flow rate on the primary circuit is greater than the one on the secondary circuit, this allows to directly control the supply temperature to the secondary one. Vice versa, if the water flow rate on the primary circuit is lower than the one on the secondary circuit, this means the supply water is mixed with the system's return water and therefore there is no direct control over the temperature of the chilled water produced.

IFWX - Steel mesh strainer on water side

The device stops the exchanger from being clogged by any impurities which are in the hydraulic circuit. The mechanical steel mesh strainer must be placed on the water input line. It can be easily dismantled for periodical maintenance and cleaning. It also includes:

- cast-iron shut-off butterfly valve with quick connections and activation lever with a mechanical calibration lock;
- quick connections with insulated casing.

STEEL KNIT FILTER PRESSURE DROP

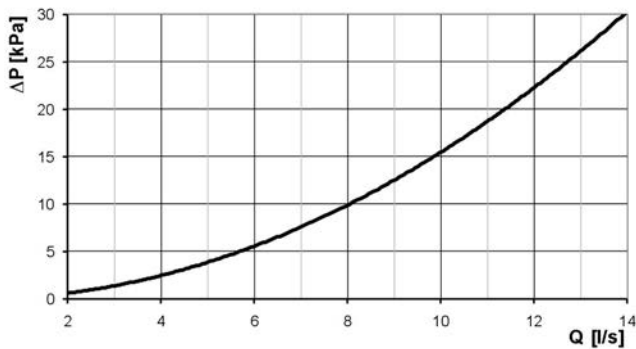

Q = water flow rate (l/s)

DP = water side pressure drops (kPa)



Pressure drop referred to a clean filter



Installation is the responsibility of the Client, externally to the unit.



Check for the presence of the required hydraulic shut-off valves in the system, in order to undertake periodical maintenance.

STEEL MESH FILTER FEATURES



Accessory separately supplied

ABU - Flush hydraulic connections

An option which simplifies the hydraulic connections which would otherwise be carried out within the unit (with the responsibility of the client).

Includes internal piping to the external unit panel, two quick connections flush to the unit, two outlet connections for the system connections which are to be soldered by the client.

The accessory is provided and installed built-in the unit.

A - Standard unit
B - Unit with ABU option

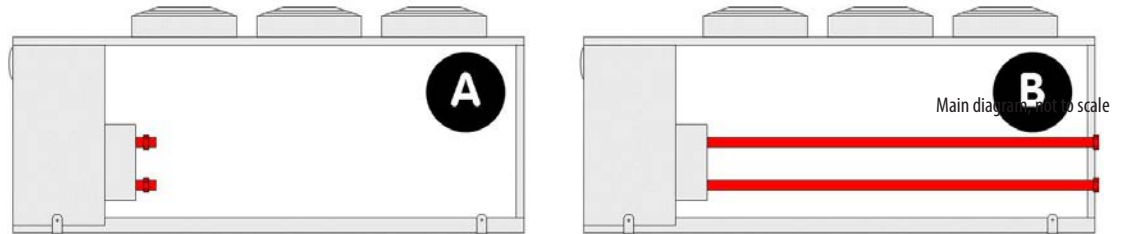

IMPORTANT!

The water connections flush with the unit are supplied as standard in units which are complete with at least one of the following options:

- Standard pump / Standard pump with standby pump
- Storage tank
- Storage tank with primary circuit built-in
- HYDROPACK



GENERAL NOTE

It is also advisable to provide the system with the following components, which are excluded from the Clivet supplies:

- Shut-off valves, if not included in Clivet's supply
- Devices to support pipes and anti-vibration elastic joints
- Expansion tank (e.g. for closed-circuit systems)
- Control thermostat on supply
- Additional vents and drains where necessary

HydroPack

2PM - Hydropack with 2 pumps

Option supplied on the unit. Pumping unit consisting of two parallel electric pumps with a self-adaptive modular activation logic.

It enables the automatic reduction of the liquid flow rate in critical conditions, avoiding blocks due to overloading and consequential intervention work by specialised technical personnel.

Centrifugal electric pump, with body and impeller made with AISI 304 steel.

Mechanical seal using ceramic, carbon and EPDM elastomer components.

Three-phase electric motor with IP44-protection. Complete with thermoformed insulated casing, quick connections with insulated casing, non return valve, safety valve, pressure gauges, system load safety pressure switch, stainless steel antifreeze immersion heaters located at the return and supply point.

The various models which are available can be differentiated by the system available pressure.

! The 2PM option is supplied as standard with the hydraulic connection kit on the system's return line (the Customer is responsible for installations outside the unit). The kit consists of: no. 1 cast-iron shut-off butterfly valve equipped with throttle drive and mechanical calibration stop; no. 1 quick coupling

! The 2PM option is supplied with a kit made up of 2 quick blind connections, for the removal of one pump in case of maintenance.

! The 2PM option is: compatible with the A300 / A500 option - 300 / 500 litre storage tank; not compatible with the A300RPS / A500RPS option- 300 / 500 litre storage tank with primary circuit in the unit

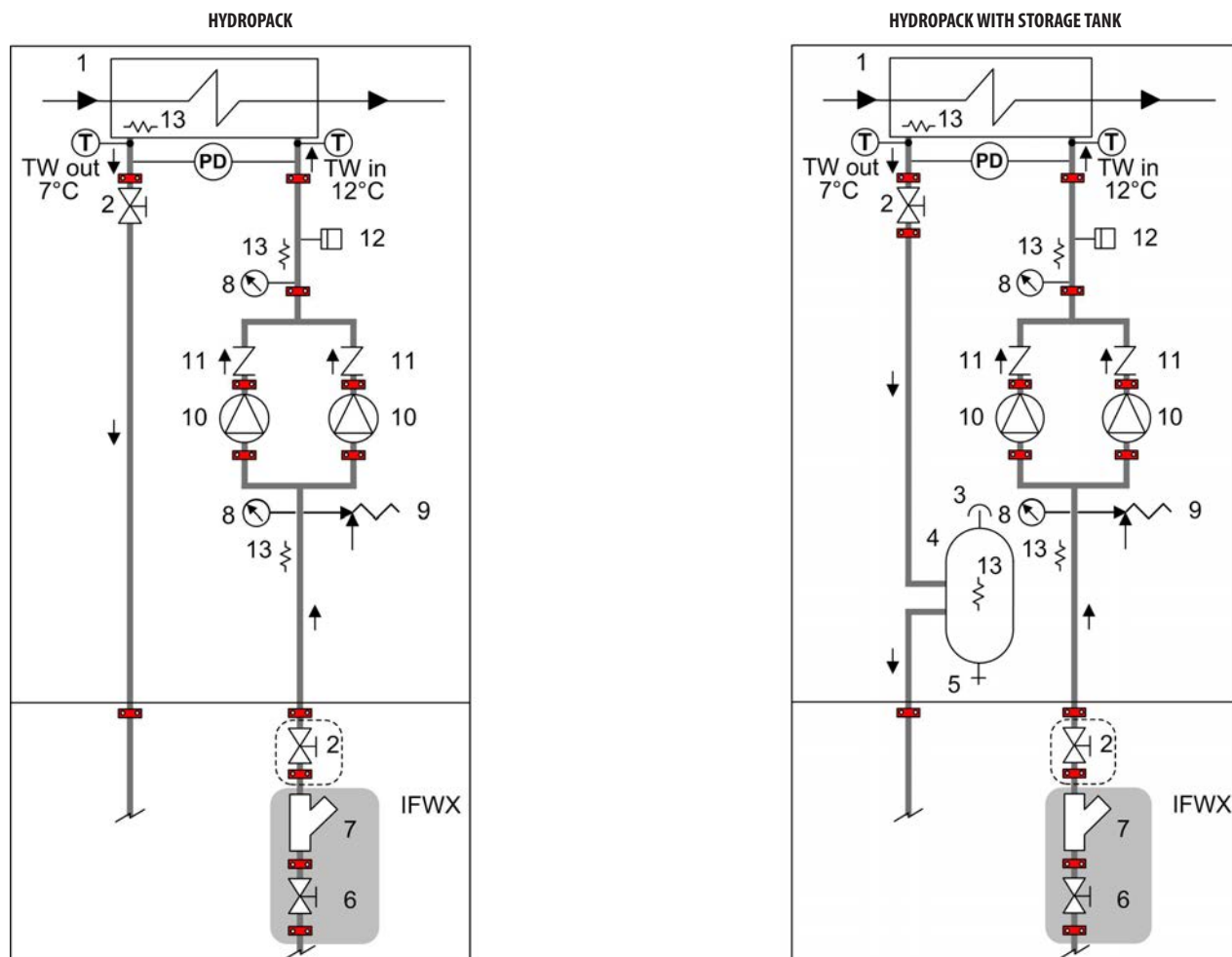

- 1 - Internal exchanger
- 2 - Cutoff valve
- 3 - Purge valve
- 4 - Storage tank with antifreeze heater
- 5 - Draw off cock
- 6 - Cutoff valve with quick joints
- 7 - Steel mesh strainer water side
- 8 - Manometer
- 9 - Safety valve (6 Bar)
- 10 - Packaged electric pump with high efficiency impeller
- 11 - Non return valve
- 12 - System safety pressure switch (prevents the pumps from operating if no water is present)
- 13 - Antifreeze heater

- TW in chilled water inlet
- TW out chilled water outlet
- IFWX = Steel mesh strainer water side
- T - Temperature probe
- PD - Differential pressure switch
- Water connection kit supplied as standard

The grey area indicates further optional components.

2PM option performances (Hydropack)

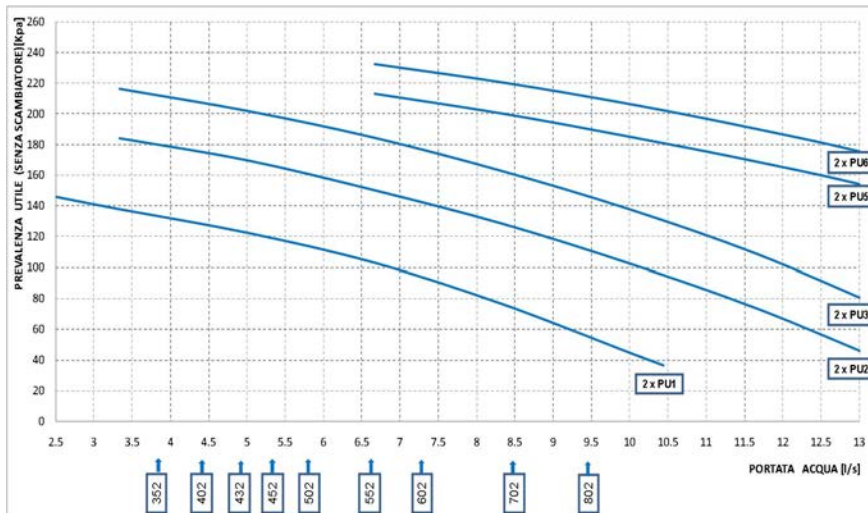

Q = Water flow rate [l/s]
 DP = Pressure drops [kPa]



Caution: to obtain the available pressure values, you need to subtract the following from the head values represented in these diagrams: –Evaporator pressure drops –IFVX accessory –Steel mesh filter on the water side (where applicable)

Hydropack technical specifications

PUMP	Rated power [kW]	Nominal power [A]
2PU1	2× 1.4	2×2.6
2PU2	2×1.4	2×2.6
2PU3	2×1.8	2×3.2
2PU5	2×2.9	2×4.8
2PU6	2×3.3	2×5.6

Accessories

PGFC - Finned coil protection grilles

This accessory is used to protect the external coil from the accidental contact with external things or people. Ideal for installation in places where persons can pass from, such as car parks, terraces, etc. The accessory is provided and installed built-in the unit.



This option is not suitable for application in sulphuric environments

PGCCH - Anti-hail protection grilles

These accessories are to protect the external coil from hail damage. Indeed, hail impact can deform the coil fins worsening the heat exchange with the air. The accessory is provided and installed built-in the unit.

CCCA - Copper / aluminium condensing coil with acrylic lining

Coils with copper pipes and aluminium fins with acrylic lacquering. Can be used in settings with moderately aggressive low saline concentrations and other chemical agents.

Attention!

- Cooling capacity variation -2.7%
- variation in compressor power input +4.2%
- operating range reduction -2.1°C

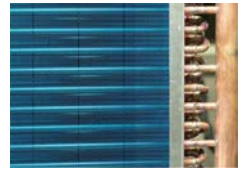

CCCA1 - Copper/aluminum condensing coil with fin guard treatment (silver)

A treatment which offers an optimal thermal exchange and guarantees and protects the finned coil exchangers from corrosion over time. Can be used in settings with very aggressive saline concentrations and other chemical agents in the air thus maintaining the performance of the coils over time.



CCCC - Copper / copper condensing coil

Coils with copper pipes, copper fins and brass structure. Can be used in settings with moderately aggressive saline concentrations and other chemical agents.



This option is not suitable for application in sulphuric environments



Option available on request

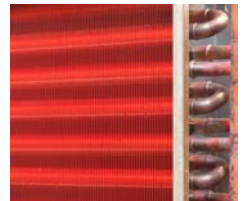

MHP - High and low pressure gauges

Although the standard unit already displays digital parameters of pressures in the refrigeration circuit, this option allows analog display of refrigerant pressures on suction and discharge lines for ease of use by maintenance technicians.

The two liquid pressure gauges and corresponding pressure sockets are installed on the machine in an easily accessible location.

The device is installed built-in the unit.



FANQE - Electrical panel ventilation

An option which regards the external helical fans, as an alternative to the ECOBREEZE device which is supplied as standard in the A-class version. It provides for an IP54 three-phase electrical motor with an external rotor and incorporated thermal protection. Supplied with variable speed control.

The device is installed and wired built-in the unit.



RE-20 / RE-25 / RE-30 / RE-35 / RE-39 - Electrical panel anti-freeze protection

This option is necessary for very cold climates, where the external temperature can be between -10°C and -39°C. It includes self-regulating temperature maintaining resistances which are able to protect the electrical panel against condensation and frost guaranteeing that it functions correctly. The choice of device should be carried out on the basis of the minimum temperatures reached at the unit installation site.

The device is installed built-in the unit.



This accessory is necessary for the unit to operate correctly in the FCD (FREE-COOLING) configuration with external temperature at less than -10°C. Furthermore, it is necessary for correct unit maintenance (not operations) in all the remaining configurations.



This accessory operates even when the unit is switched off provided that the power supply is maintained active and the unit continues to be connected.



This accessory does not lead to substantial variations in the electrical data for the unit which has been declared in the Electrical Data section.



PFCP - Power-factor capacitors

The component is necessary to lower the phase difference between current and voltage in the electromagnetic components of the unit (e.g. asynchronous motors). The component allows to put the cosφ power factor to values on average higher than 0.9, reducing the network reactive power. This often leads to an economic benefit which the energy provider grants to the final user.

The device is installed built-in the unit.



ECS - ECOSHARE function for the automatic management of a group of units

The device allows automatic management of units that operate on the same hydraulic circuit, by creating a local communication network.

There are two control modes that can be set via a parameter during the activation stage. They both distribute the heat load on the available units by following the distribution logic to benefit from efficiency levels at part load.

Moreover:

Mode 1 - it keeps all the pumps active

Mode 2 - it activates only the pumps of the unit required to operate

The device allows for rotation based on the criterion of minimum wear and management of units in stand-by. There are various unit sizes. Every unit must be fitted with the ECOSHARE feature. The set of units is controlled by a Master unit.

The local network can be extended up to 7 units (1 Master and 6 Slave).



The unit supplied with this device can also be equipped at the same time with the RCMRX option and one of the CMSC8 / CMSC9 / CMSC10 options.

SFSTR - Starting current reduction device

This option is also known as “Soft starter”. An electronic device which automatically starts up the compressors gradually, reducing the starting current for the unit by around 40% in comparison with the nominal value.

This results in the electrical capacity system and the related protection devices being sized with lower parameters, thus having a lower initial investment cost.

The device is installed and wired built-in the unit.

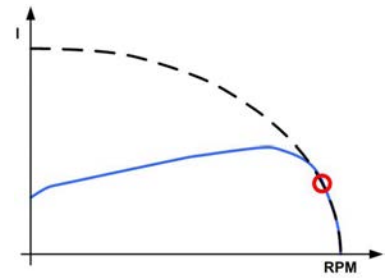

— Absorbed current without SFSTR option
— Absorbed current without SFSTR option

ELFOEnergy Large² electrical data (WSAN-XEE SERIES) with SFSTR option

Size		352	402	432	452	502	552	602	702	802
M.I.C. Maximum inrush current										
M.I.C. - Value	A	167	179	189	216	222	230	244	298	313

CMSC8 - Serial communication module for BACnet supervisor

Allows the serial connection to supervision systems, by using BACnet as communication protocol. It allows the access to the entire list of operation variables, controls and alarms. With this accessory, every unit can communicate with the main supervision systems.

The device is installed and wired built-in the unit.

The configuration and management activities for the BACnet networks are the responsibility of the client.

The total length of each serial line do not exceed 1000 meters and the line must be connected in bus typology (in/out)



CMSC9 - Serial communication module for Modbus supervisor

This enables the serial connection of the supervision system, using Modbus as the communication protocol. It enables access to the complete list of operational variables, commands and alarms. Using this accessory every unit can dialogue with the main supervision systems.

The device is installed and wired built-in the unit.

The total length of each serial line do not exceed 1000 meters and the line must be connected in bus typology (in/out)



CMSC10 - Serial communication module for LonWorks supervisor

This enables the serial connection of the supervision system which uses the LonWorks communication protocol. It enables access to a list of operating variables, commands and alarms which comply with the Echelon® standard.

The device is installed and wired built-in the unit.

The configuration and management activities for the BACnet networks are the responsibility of the client.

LonWorks technology uses the LonTalk® protocol for communicating between the network nodes. Contact the service supplier for further information.

The total length of each serial line do not exceed 1000 meters and the line must be connected in bus typology (in/out)



CREFP - External section fan consumption reduction device at variable speed (phase-cutting)

An option which regards the external helical fans, as an alternative to the ECOBREEZE device which is supplied as standard in the EXCELLENCE version. It provides for an IP54 three-phase electrical motor with an external rotor and incorporated thermal protection. Supplied with variable speed control.

The device is installed and wired built-in the unit.

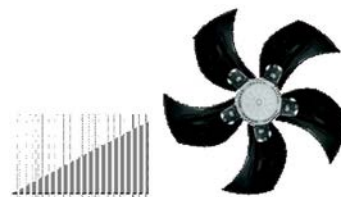

CONTA2 - Energy meter

Allows to display and record the unit's main electrical parameters. The data can be displayed with the user interface on the unit or via the supervisor through the specific protocol variables.

It is possible to control:

- voltage (V),
- absorbed current (A),
- frequency (Hz),
- $\cos\phi$,
- power input (KW),
- absorbed energy (KWh),
- harmonic components (%).

The device is installed and wired built-in the unit.

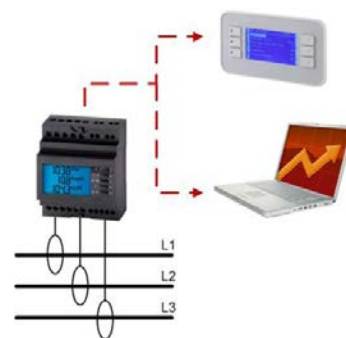

Only the following parameters are available on the LonWorks protocol: power input (kW) and absorbed energy (kWh)

SPC4 - Set-point compensation with 0-10 V signal

This device enables the set-point to be varied which is pre-set using an external 0÷10V signal.

The device is installed and wired built-in the unit.



SPC2 - set point compensation with outdoor air probe

This device enables the set-point to be varied automatically which is pre-set depending on the enthalpy of the outdoor air. This device enables the liquid flow temperature to be obtained, which varies depending on external conditions, enabling energy savings throughout the entire system.

The device is installed and wired built-in the unit.



OHE - Kit of heating limit extension up to -10°C (W.B.)

The device allows to extend heating unit operation ranges up to -10°C wet bulb outdoor temperature. Clivet automatic control ensures the unit ongoing operating and at full capacity.

The device is installed and wired built-in the unit.

OPERATING RANGE IN HEATING

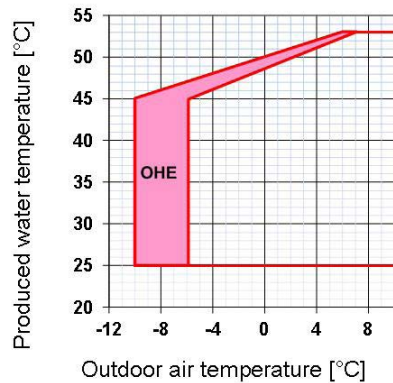

Accessories separately supplied

RCMRX - Remote control via microprocessor remote control

This option allows to have full control over all the unit functions from a remote position.

It can be easily installed on the wall and has the same aspect and functions of the user interface on the unit.

- All device functions can be repeated with a normal portable PC connected to the unit with an Ethernet cable and equipped with an internet navigation browser.
- The device must be installed on the wall with suitable plugs and connected to the unit (installation and wiring to be conducted by the Customer). Maximum remote control distance 350 m without auxiliary power supply. For distances greater than 350 m and in any case less than 700 m it is necessary to install the 'PSX - Mains power unit' accessory.
- Data and power supply serial connection cable n.1 twisted and shielded pair. Diameter of the individual conductor 0.8 mm.

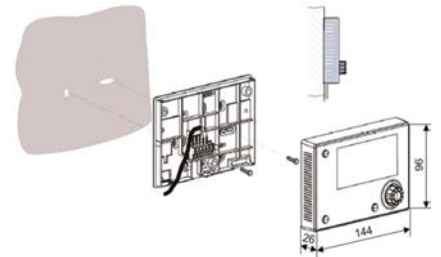

PSX - Mains power supply unit

The device allows the unit and the remote control to communicate with the user interface even when the serial line is longer than 350m.

It must be connected to the serial line at a distance of 350m from the unit and allows to extend the length to 700m maximum in total. The device requires an external power supply at 230V AC.

- Power supply at 230V AC provided by Customer



AMMX - Spring antivibration mounts

The spring antivibration mounts are attached in special housing on the support frame and serve to smooth the vibrations produced by the unit thus reducing the noise transmitted to the support structure.



Correction factors for glycol use

% ethylene glycol by weight		5%	10%	15%	20%	25%	30%	35%	40%
Freezing temperature	°C	-2,0	-3,9	-6,5	-8,9	-11,8	-15,6	-19,0	-23,4
Safety temperature	°C	3,0	1,0	-1,0	-4,0	-6,0	-10,0	-14,0	-19,0
Cooling Capacity Factor	No	0,995	0,99	0,985	0,981	0,977	0,974	0,971	0,968
Compressor power input Factor	No	0,997	0,993	0,99	0,988	0,986	0,984	0,982	0,981
Internal exchanger glycol solution flow factor	No	1,003	1,01	1,02	1,033	1,05	1,072	1,095	1,124
Pressure drop Factor	No	1,029	1,06	1,09	1,118	1,149	1,182	1,211	1,243

The correction factors shown refer to water and glycol ethylene mixes used to prevent the formation of frost on the exchangers in the water circuit during inactivity in winter.

Fouling Correction Factors

m2 K / W	Internal exchanger	
	F1	FK1
0.44 x 10 (-4)	1,0	1,0
0.88 x 10 (-4)	0,97	0,99
1.76 x 10 (-4)	0,94	0,98

F1 = Cooling capacity correction factors

FK1 = Compressor power input correction factor

Overload and control device calibrations

			open	closed	value
high pressure safety pressure switch		[kPa]	4050	3300	-
low pressure safety switch		[kPa]	450	600	-
low pressure switch (Brine)		[kPa]	200	350	-
antifreeze protection		[°C]	3	5.5	-
high pressure safety valve		[kPa]	-	-	4500
low pressure safety valve		[kPa]	-	-	3000
Max no. of compressor starts per hour		[n°]	-	-	10
high compressor discharge temperature safety thermostat		[°C]	-	-	120

Exchanger operating range

	Internal exchanger	
	DPr	DPw
	[kPa]	[kPa]
PED (CE)	4500	1000

DPr = Max. operating pressure refrigerant gas side

DPw = Max. operating pressure water side (utility)

Integrated heating capacities

Air temperature external exchanger inlet °C (D.B. / W.B.)	-5/-5.4	0/-0.6	5/3.9	OTHERS
Heating capacity multiplication coefficient	0.90	0.91	0.96	1

To obtain the integrated heating capacities (the real heating capacity considering the defrost cycles too), multiply the kWt value in the heating performance tables by the following coefficient.

Option compatibility - WSAN-XEE series

OPTIONS	DESCRIPTION	352	402	432	452	502	552	602	702	802
D - Standard condensing coil										
1PUS	Standard pump,	0	0	0	0	0	0	0	0	0
1PU1SB	n°1 pump +1 in stand-by,	0	0	0	0	0	0	0	0	0
1PUS + A300	Standard pump, 300-litre storage tank	0	0	0	0	0	0	0	0	0
1PU1SB + A300	n°1 pump +1 in stand-by, 300-litre storage tank	0	0	0	0	0	0	0	0	0
1PUS + A500	Standard pump, 500-litre storage tank	0	0	0	0	0	0	0	0	0
1PU1SB + A500	n°1 pump +1 in stand-by, 500-litre storage tank	0	0	0	0	0	0	0	0	0
1PUS - STANDARD PUMP										
PU1	Pump type 1,	0	0	0	X	X	X	X	X	X
PU2	Pump type 2,	0	0	0	0	0	X	X	X	X
PU3	Pump type 3,	0	0	0	0	0	X	X	X	X
PU4	Pump type 4,	0	0	0	0	0	0	0	0	0
PU5	Pump type 5,	0	0	0	0	0	0	0	0	0
PU6	Pump type 6,	0	0	0	0	0	0	0	0	0
A300	300-litre storage tank,	0	0	0	0	0	0	0	X	X
A500	500-litre storage tank	X	X	X	X	X	X	X	0	0
PU1 + A300RPS	Pump type 1, 300-litre storage tank with antifreeze heater and primary-secondary circuit	0	0	0	X	X	X	X	X	X
PU4 + A300RPS	Pump type 4, 300-litre storage tank with antifreeze heater and primary-secondary circuit	X	X	X	0	0	0	0	X	X
PU4 + A500RPS	Pump type 4, 500-litre storage tank with antifreeze heater and primary-secondary circuit	X	X	X	X	X	X	X	0	0
1PU1SB - N°1 POMPA + 1 IN STAND BY										
PU1	Pump type 1,	0	0	0	X	X	X	X	X	X
PU2	Pump type 2,	0	0	0	0	0	X	X	X	X
PU3	Pump type 3,	0	0	0	0	0	X	X	X	X
PU4	Pump type 4,	0	0	0	0	0	0	0	0	0
PU5	Pump type 5,	0	0	0	0	0	0	0	0	0
PU6	Pump type 6,	0	0	0	0	0	0	0	0	0
A300	300-litre storage tank,	0	0	0	0	0	0	0	X	X
A500	500-litre storage tank	X	X	X	X	X	X	X	0	0
PU1 + A300RPS	Pump type 1, 300-litre storage tank with antifreeze heater and primary-secondary circuit	0	0	0	X	X	X	X	0	0
PU4 + A300RPS	Pump type 4, 300-litre storage tank with antifreeze heater and primary-secondary circuit	X	X	X	0	0	0	0	X	X
PU4 + A500RPS	Pump type 4, 500-litre storage tank with antifreeze heater and primary-secondary circuit	X	X	X	X	X	X	X	0	0
2PM - HYDROPACK WITH N°2 PUMP										
PU1	Pump type 1,	0	0	0	0	0	0	0	0	X
PU2	Pump type 2,	0	0	0	0	0	0	0	0	0
PU3	Pump type 3,	0	0	0	0	0	0	0	0	0
PU5	Pump type 5,	X	X	X	X	X	X	0	0	0
PU6	Pump type 6,	X	X	X	X	X	X	0	0	0
A300	300-litre storage tank,	0	0	0	0	0	0	0	X	X
A500	500-litre storage tank	X	X	X	X	X	X	X	0	0
PU1 + A300RPS	Pump type 1, 300-litre storage tank with antifreeze heater and primary-secondary circuit	0	0	0	0	0	0	0	X	X
PU1 + A500RPS	Pump type 1, 500-litre storage tank with antifreeze heater and primary-secondary circuit	X	X	X	X	X	X	X	0	0

◦ Option

× Not available

Dimensional drawings

WSAN-XEE 352-402-432-452-502

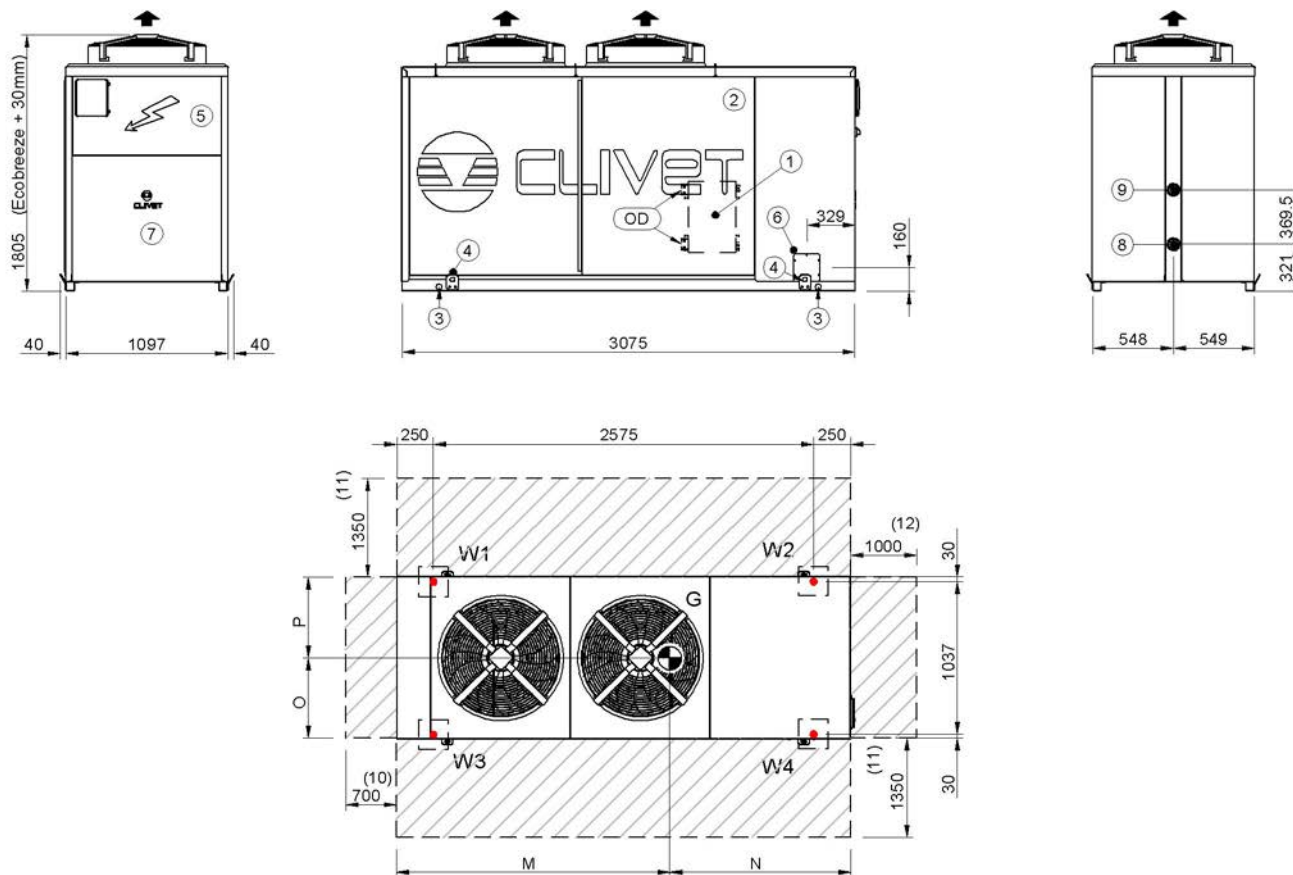

- | | |
|--|--|
| 1. Internal exchanger (evaporator) | 8. Internal exchanger water inlet |
| 2. External exchanger (condenser) | 9. Internal exchanger water outlet |
| 3. Unit fixing holes | 10. Minimum Safe Clearance |
| 4. Lifting brackets (removable, if required, after positioning the unit) | 11. Minimum Clearance for a Proper Air flow to the Condenser |
| 5. Electrical panel | 12. Minimum Clearance Electrical Panel Side |
| 6. Power input | 13. Barycentre |
| 7. Soundproofed cabin | |

Size			SC					EN				
			352	402	432	452	502	352	402	432	452	502
M	mm		1965	1955	2021	2001	2016	1965	1955	2021	2001	2016
N	mm		1110	1120	1054	1074	1059	1110	1120	1054	1074	1059
O	mm		575	577	586	584	586	575	577	586	584	586
P	mm		522	520	511	513	511	522	520	511	513	511
OD	mm		76.1	76.1	76.1	76.1	76.1	76.1	76.1	76.1	76.1	76.1
Length	mm		3075	3075	3075	3075	3075	3075	3075	3075	3075	3075
Depth	mm		1097	1097	1097	1097	1097	1097	1097	1097	1097	1097
Height	mm		1805	1805	1805	1805	1805	1805	1805	1805	1805	1805
W1 Supporting Point	kg		146	158	158	169	170	146	158	158	169	170
W2 Supporting Point	kg		335	356	408	418	433	335	356	408	418	433
W3 Supporting Point	kg		160	172	172	183	184	160	172	172	183	184
W4 Supporting Point	kg		275	290	320	330	339	275	290	320	330	339
W5 Supporting Point	kg		0.0	0.0	0.0	0.0	0.0	0.0	0.0	0.0	0.0	0.0
W6 Supporting Point	kg		0.0	0.0	0.0	0.0	0.0	0.0	0.0	0.0	0.0	0.0
Shipping weight	kg		910	970	1053	1093	1117	910	970	1053	1093	1117
Operating weight	kg		915	975	1059	1101	1126	915	975	1059	1101	1126

Particular accessories, executions or versions can bring about a great variation of the mass represented here. Please contact our Technical Department.

WSAN-XEE 552-602

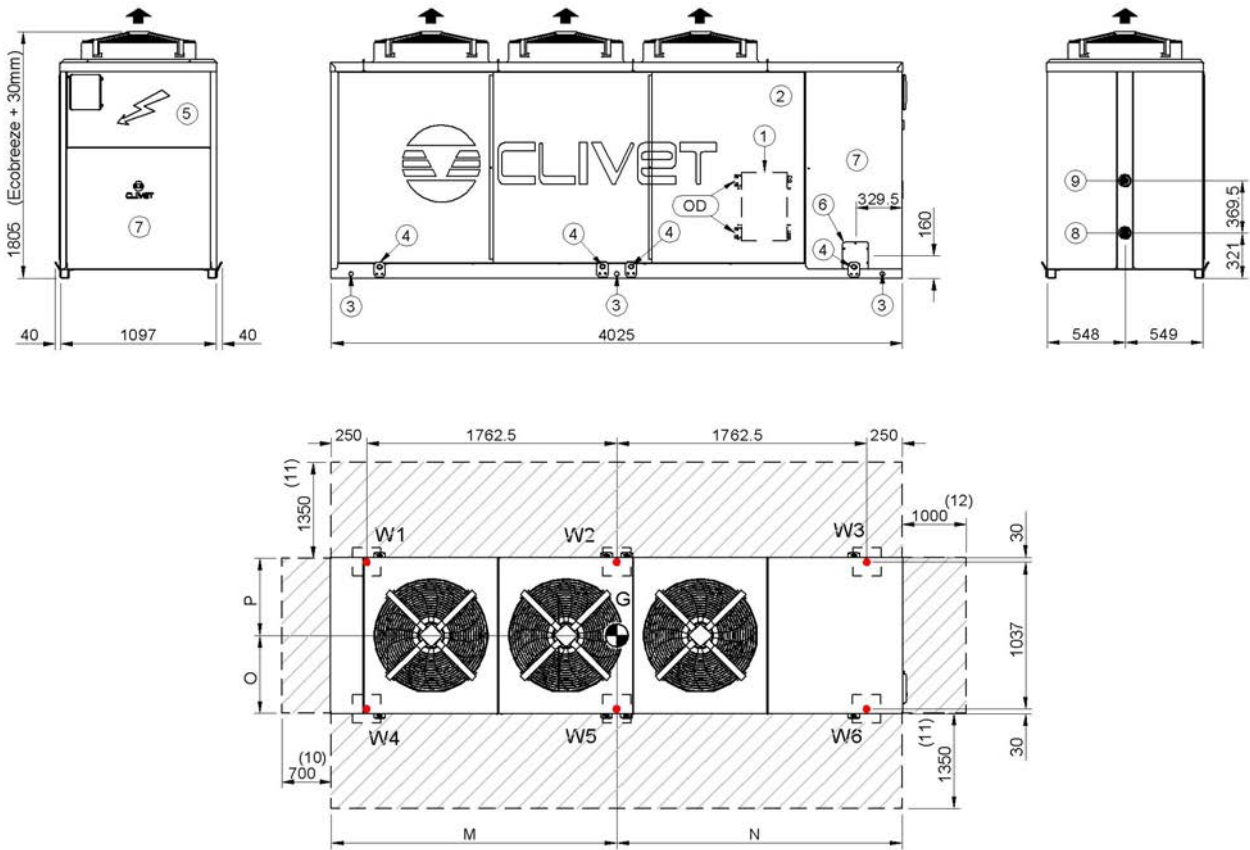

- | | |
|--|--|
| 1. Internal exchanger (evaporator) | 8. internal exchanger water inlet |
| 2. External exchanger (condenser) | 9. internal exchanger water outlet |
| 3. Unit fixing holes | 10. Minimum Safe Clearance |
| 4. lifting brackets (removable, if required, after positioning the unit) | 11. Minimum Clearance for a Proper Air flow to the Condenser |
| 5. Electrical panel | 12. Minimum Clearance Electrical Panel Side |
| 6. Power input | 13. Barycentre |
| 7. Soundproofed cabin | |

Size			SC		EN	
			552	602	552	602
M		mm	2615	2628	2615	2628
N		mm	1410	1397	1410	1397
O		mm	565	566	565	566
P		mm	532	531	532	531
OD		mm	76	76	76	76
Length		mm	4025	4025	4025	4025
Depth		mm	1097	1097	1097	1097
Height		mm	1805	1805	1805	1805
W1 Supporting Point		kg	77	77	77	77
W2 Supporting Point		kg	278	278	278	278
W3 Supporting Point		kg	329	338	329	338
W4 Supporting Point		kg	82	82	82	82
W5 Supporting Point		kg	276	276	276	276
W6 Supporting Point		kg	283	290	283	290
Shipping weight		kg	1315	1330	1315	1330
Operating weight		kg	1326	1341	1326	1341

Particular accessories, executions or versions can bring about a great variation of the mass represented here. Please contact our Technical Department.

WSAN-XEE 702-802

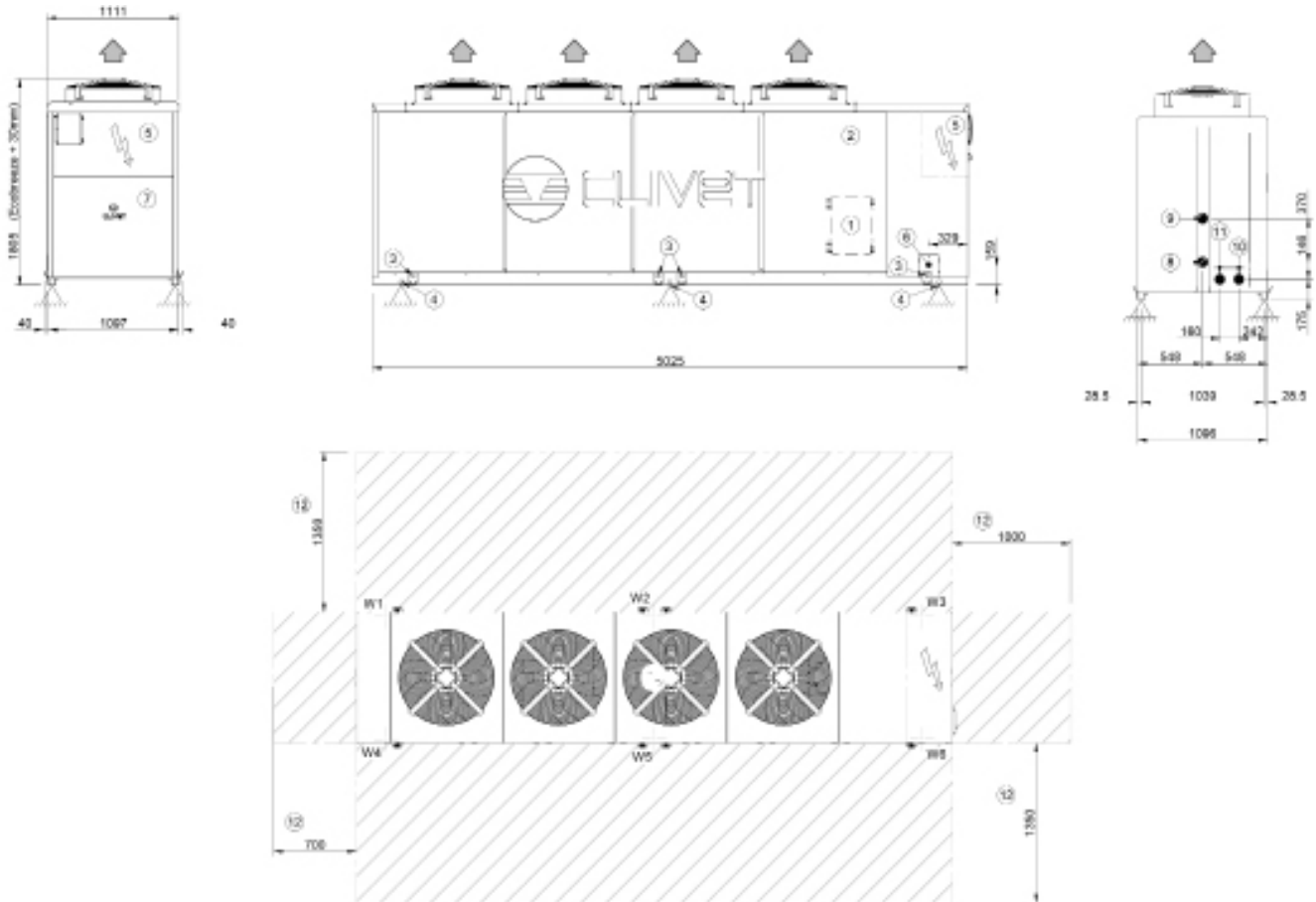

1. Internal exchanger (evaporator)
2. External exchanger (condenser)
3. Unit fixing holes
4. lifting brackets (removable, if required, after positioning the unit)
5. Electrical panel
6. Power input
7. Soundproofed cabin
8. internal exchanger water inlet (OD=2"1/2 Victaulic type)
9. internal exchanger water outlet (OD=2"1/2 Victaulic type)
10. Partial/total recovery exchanger water inlet (OD=1 1/4"-2" Victaulic type)
11. Partial/total recovery exchanger water outlet (OD=1 1/4"-2" Victaulic type)
12. Functional spaces

Size			SC		EN	
			702	802	702	802
M		mm	3383	3396	3383	3396
N		mm	1642	1629	1642	1629
O		mm	563	565	563	565
P		mm	534	532	534	532
OD		mm	76	76	76	76
Length		mm	5025	5025	5025	5025
Depth		mm	1097	1097	1097	1097
Height		mm	1805	1805	1805	1805
W1 Supporting Point		kg	85	85	85	85
W2 Supporting Point		kg	302	302	302	302
W3 Supporting Point		kg	410	420	410	420
W4 Supporting Point		kg	79	79	79	79
W5 Supporting Point		kg	325	325	325	325
W6 Supporting Point		kg	349	354	349	354
Shipping weight		kg	1535	1550	1535	1550
Operating weight		kg	1549	1564	1549	1564

Particular accessories, executions or versions can bring about a great variation of the mass represented here. Please contact our Technical Department.

FOR OVER 30 YEARS WE HAVE BEEN
OFFERING SOLUTIONS TO ENSURE
SUSTAINABLE COMFORT AND THE WELL-
BEING OF PEOPLE AND THE ENVIRONMENT

www.clivet.com **MideaGroup**
humanizing technology

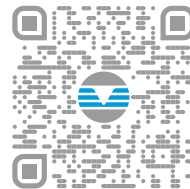

sale and assistance

ELFOEnergy Large² - WSAN-XEE 352-802 - BT12N003GB-11



CLIVET S.p.A.

Via Camp Lonc 25, Z.I. Villapaiera
32032 Feltre (BL) - Italy
Tel. +39 0439 3131 - info@clivet.it

CLIVET GMBH

Hummelsbütteler Steindamm 84,
22851 Norderstedt, Germany
Tel. +49 40 325957-0 - info.de@clivet.com

Clivet Group UK LTD

Units F5 & F6 Railway Triangle,
Portsmouth, Hampshire PO6 1TG
Tel. +44 02392 381235 -
Enquiries@Clivetgroup.co.uk

CLIVET LLC

Office 508-511, Elektroavodskaya st. 24,
Moscow, Russian Federation, 107023
Tel. +7495 6462009 - info.ru@clivet.com

CLIVET MIDEAST FZCO

Dubai Silicon Oasis (DSO) Headquarter
Building, Office EG-05, P.O Box-342009,
Dubai, UAE
Tel. +9714 3208499 - info@clivet.ae

Clivet South East Europe

Jarušćica 9b
10000, Zagreb, Croatia
Tel. +385916065691 - info.see@clivet.com

Clivet Airconditioning Systems Pvt Ltd

Office No.501 & 502,5th Floor, Commercial -I,
Kohinoor City, Old Premier Compound, Off
LBS Marg, Kiroi Road, Kurla West, Mumbai
Maharashtra 400070, India
Tel. +91 22 30930200 - sales.india@clivet.com