



HYDRO-M

IHM1-Y series 80M



MANUAL
FOR INSTALLATION,
USE AND MAINTENANCE

GB

Table of Contents

Safety Precautions	04
--------------------------	----

Owner's Manual

Indoor Unit Parts And Major Functions.....	08
1. Unit Parts.....	08
2. Operating temperature.....	09
Operations.....	10
Care and Maintenance.....	15
Troubleshooting.....	17



IMPORTANT NOTE:

Read this manual carefully before installing or operating your new air conditioning unit. Make sure to save this manual for future reference.

Please check the applicable models, technical data, F-GAS(if any) and manufacturer information from the "Owner's Manual - Product Fiche " in the packaging of the outdoor unit. (European Union products only)

Installation Manual

Accessories	20
Installation Summary	21
Unit Parts	22
Indoor Unit Installation	25
1. Select installation location	25
2. Dimensions and service space.....	25
3. Mounting the indoor unit.....	26
4. Water filling and anti freezing measures	26
5. Description of water pump exhaust	27
Outdoor Unit Installation.....	28
1. Select installation location.....	28
2. Install drain joint(Heat pump unit only)	29
3. Anchor outdoor unit	29
Refrigerant Piping Connection	31
Connection Instructions –Refrigerant Piping.....	32
1. Cut pipes	32
2. Remove burrs	32
3. Flare pipe ends	33
4. Connect pipes	33
Wiring	35
1. Outdoor Unit Wiring	36
2. Indoor Unit Wiring	37
3. Field wiring.....	38
Air Evacuation	41
1. Evacuation Instructions	41
2. Note on Adding Refrigerant	42
Test Run	43

Safety Precautions

Read Safety Precautions Before Operation and Installation

Incorrect installation due to ignoring instructions can cause serious damage or injury.

The seriousness of potential damage or injuries is classified as either a **WARNING** or **CAUTION**.



WARNING

This symbol indicates the possibility of personnel injury or loss of life.



CAUTION

This symbol indicates the possibility of property damage or serious consequences.



WARNING

- The hydraulic module must be earthed effectively.
A residual current operated circuit-breakers with integral overcurrent protection must be installed on the external power supply line of the unit.
Do not tear off the labels on the units for the purpose of warning or reminding.
- This appliance can be used by children aged from 8 years and above and persons with reduced physical, sensory or mental capabilities or lack of experience and knowledge if they have been given supervision or instruction concerning use of the appliance in a safe way and understand the hazards involved. Children shall not play with the appliance. Cleaning and user maintenance shall not be made by children without supervision.
- This appliance is not intended for use by persons (including children) with reduced physical, sensory or mental capabilities, or lack of experience and knowledge, unless they have been given supervision or instruction concerning use of the appliance by a person responsible for their safety. Children should be supervised to ensure that they do not play with the appliance.



WARNINGS FOR PRODUCT USE

- If an abnormal situation arises (like a burning smell), immediately turn off the unit and disconnect the power. Call your dealer for instructions to avoid electric shock, fire or injury.
- Do not use flammable sprays such as hair spray, lacquer or paint near the unit. This may cause fire or combustion.
- Do not operate the air conditioner in places near or around combustible gases. Emitted gas may collect around the unit and cause explosion.
- Do not operate your air conditioner in a wet room such as a bathroom or laundry room. Too much exposure to water can cause electrical components to short circuit.
- Do not allow children to play with the air conditioner. Children must be supervised around the unit at all times.
- If the air conditioner is used together with burners or other heating devices, thoroughly ventilate the room to avoid oxygen deficiency.
- In certain functional environments, such as kitchens, server rooms, etc., the use of specially designed air-conditioning units is highly recommended.
- Never touch the air outlet or the horizontal blades while the swing flap is in operation. Fingers may become caught or the unit may break down.
- Never put any objects into the air inlet or outlet. Objects touching the fan of high speed can be dangerous.
- Do not use the Hydraulic module for other purposes.

CLEANING AND MAINTENANCE WARNINGS

- Turn off the device and disconnect the power before cleaning. Failure to do so can cause electrical shock.
- Do not clean the air conditioner with excessive amounts of water.
- Do not clean the air conditioner with combustible cleaning agents. Combustible cleaning agents can cause fire or deformation.

CAUTION

- Turn off the air conditioner and disconnect the power if you are not going to use it for a long time.
- Turn off and unplug the unit during storms.
- Do not operate the air conditioner with wet hands. This may cause electric shock.
- Do not use device for any other purpose than its intended use.
- Do not climb onto or place objects on top of the outdoor unit.

ELECTRICAL WARNINGS

- Before beginning any installation, handling or repair work on the heat pump, always isolate the electrical power supply to the unit.
- Only use the specified power cord. If the power cord is damaged, it must be replaced by the manufacturer, its service agent or similarly qualified persons in order to avoid a hazard.
- Keep power plug clean. Remove any dust or grime that accumulates on or around the plug. Dirty plugs can cause fire or electric shock.
- Do not pull power cord to unplug unit. Hold the plug firmly and pull it from the outlet. Pulling directly on the cord can damage it, which can lead to fire or electric shock.
- Do not modify the length of the power supply cord or use an extension cord to power the unit.
- Do not share the electrical outlet with other appliances. Improper or insufficient power supply can cause fire or electrical shock.
- The product must be properly grounded at the time of installation, or electrical shock may occur.
- For all electrical work, follow all local and national wiring standards, regulations, and the Installation Manual. Connect cables tightly, and clamp them securely to prevent external forces from damaging the terminal. Improper electrical connections can overheat and cause fire, and may also cause shock. All electrical connections must be made according to the Electrical Connection Diagram located on the panels of the indoor and outdoor units.
- All wiring must be properly arranged to ensure that the control board cover can close properly. If the control board cover is not closed properly, it can lead to corrosion and cause the connection points on the terminal to heat up, catch fire, or cause electrical shock.
- If connecting power to fixed wiring, an all-pole disconnection device which has at least 3mm clearances in all poles, and have a leakage current that may exceed 10mA, the residual current operated circuit-breakers with integral overcurrent protection having a rated residual operating current not exceeding 30mA, and disconnection must be incorporated in the fixed wiring in accordance with the wiring rules.
- Do not turn off the power supply. System will stop or restart heating automatically. A continuous power supply for water heating is necessary, except service and maintenance.

TAKE NOTE OF FUSE SPECIFICATIONS

The air conditioner's circuit board (PCB) is designed with a fuse to provide overcurrent protection. The specifications of the fuse are printed on the circuit board ,examples of such are T5A/250VAC and T16A/250VAC.

 **WARNINGS FOR PRODUCT INSTALLATION**

- Installation must be performed by an authorized dealer or specialist. Defective installation can cause water leakage, electrical shock, or fire.
- Installation must be performed according to the installation instructions. Improper installation can cause water leakage, electrical shock, or fire.
(In North America, installation must be performed in accordance with the requirement of NEC and CEC by authorized personnel only.)
- Contact an authorized service technician for repair or maintenance of this unit. This appliance shall be installed in accordance with national wiring regulations.
- Only use the included accessories, parts, and specified parts for installation. Using non-standard parts can cause water leakage, electrical shock, fire, and can cause the unit to fail.
- Install the unit in a firm location that can support the unit's weight. If the chosen location cannot support the unit's weight, or the installation is not done properly, the unit may drop and cause serious injury and damage.
- Install drainage piping according to the instructions in this manual. Improper drainage may cause water damage to your home and property.
- For units that have an auxiliary electric heater, do not install the unit within 1 meter (3 feet) of any combustible materials.
Do not install the unit in a location that may be exposed to combustible gas leaks. If combustible gas accumulates around the unit, it may cause fire.
- Do not turn on the power until all work has been completed.
When moving or relocating the air conditioner, consult experienced service technicians for disconnection and reinstallation of the unit.
- How to install the appliance to its support, please read the information for details in "indoor unit installation" and "outdoor unit installation" sections .

Note about Fluorinated Gasses(Not applicable to the unit using R290 Refrigerant)

- This air-conditioning unit contains fluorinated greenhouse gasses. For specific information on the type of gas and the amount, please refer to the relevant label on the unit itself or the "Owner's Manual - Product Fiche " in the packaging of the outdoor unit. (European Union products only).
- Installation, service, maintenance and repair of this unit must be performed by a certified technician.
- Product uninstallation and recycling must be performed by a certified technician.
- For equipment that contains fluorinated greenhouse gases in quantities of 5 tonnes of CO₂ equivalent or more, but of less than 50 tonnes of CO₂ equivalent, If the system has a leak-detection system installed, it must be checked for leaks at least every 24 months.
- When the unit is checked for leaks, proper record-keeping of all checks is strongly recommended.

European Disposal Guidelines

This marking shown on the product or its literature, indicates that waste electrical and electrical equipment should not be mixed with general household waste.



Correct Disposal of This Product
(Waste Electrical & Electronic Equipment)

This appliance contains refrigerant and other potentially hazardous materials. When disposing of this appliance, the law requires special collection and treatment. Do not dispose of this product as household waste or unsorted municipal waste.

When disposing of this appliance, you have the following options:

- Dispose of the appliance at designated municipal electronic waste collection facility.
- When buying a new appliance, the retailer will take back the old appliance free of charge.
- The manufacturer will take back the old appliance free of charge.
- Sell the appliance to certified scrap metal dealers.

Special notice

Disposing of this appliance in the forest or other natural surroundings endangers your health and is bad for the environment. Hazardous substances may leak into the ground water and enter the food chain.

WARNING

This unit is required reliable earthing before usage, otherwise might cause death or injury.

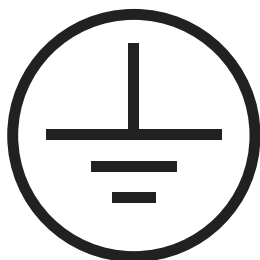

Please ask skilled service persons for reliable earthing connection.

Indoor Unit Parts And Major Functions

Unit Parts

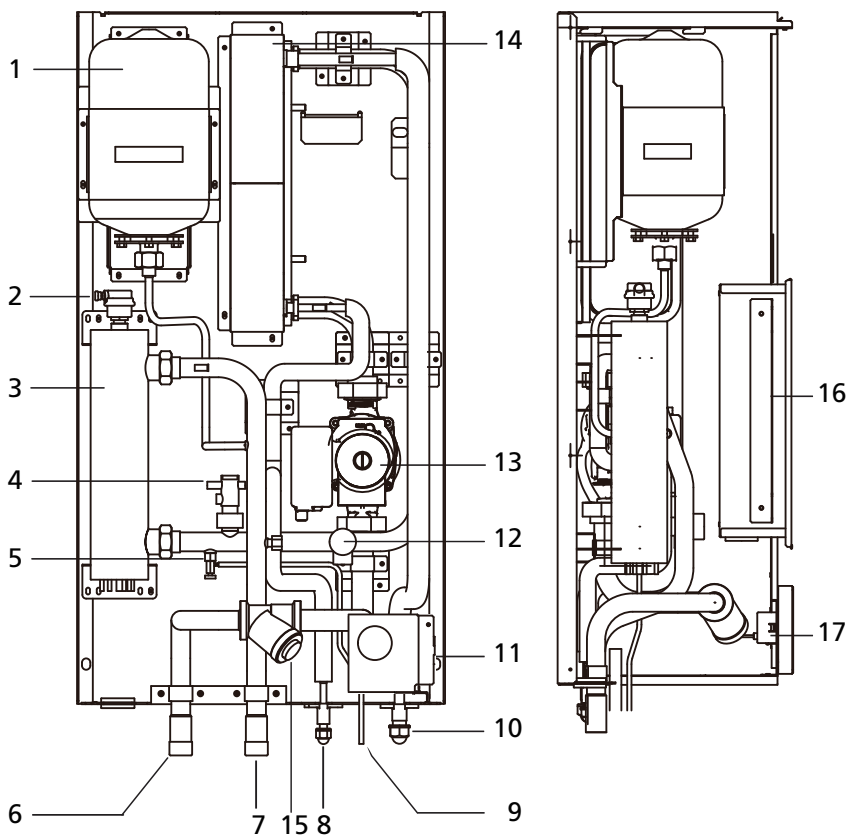
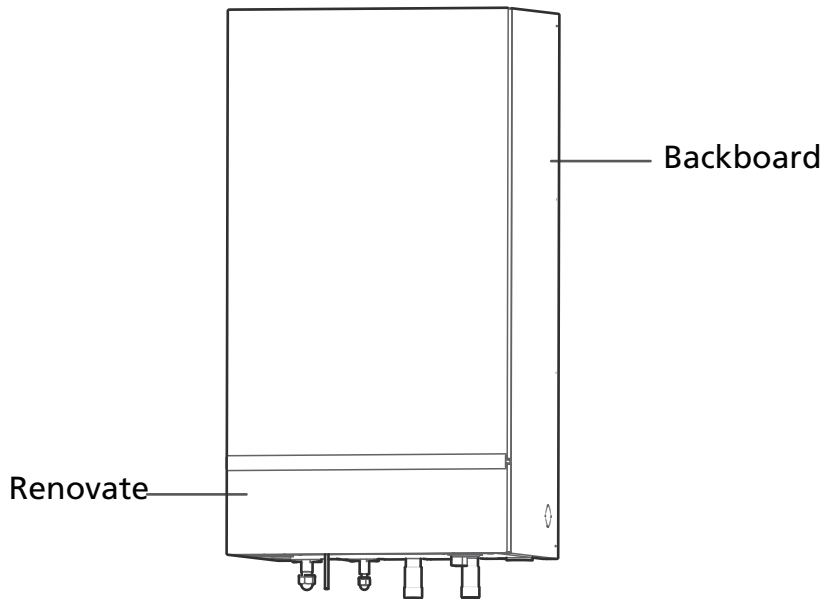

1. Expansion Vessel
2. Automatic air purge valve
3. Auxiliary heater vessel
4. Flow switch
5. Drain valve
6. Water inlet Ø1" (welded connections)
7. Water outlet Ø1" (welded connections)
8. Refrigerant liquid connection
9. Drainage
10. Refrigerant gas connection
11. Manometer
12. Relief valve
13. Pump
14. Refrigerant to water heat exchanger
15. Y-style filter
(There is an filter inside.)
16. Electric control box
17. Wire controller

Operating temperature

When your unit is used outside of the following temperature ranges, certain safety protection features may activate and cause the unit to disable.

	HEAT mode	DHW mode
Room Temperature	0°C - 30°C (32°F - 86°F)	— —
Outdoor Temperature	-15°C - 24°C (5°F - 75°F)	-15°C - 43°C (5°F - 109°F)

Operations

Operating the heat pump comes down to operating the wire controller. The wire controller is a state of the art controller that offers full control over your installation. Some functions described in this manual may not be available or should not be available. Ask your installer for more information.

⚠ CAUTION

- Never let the wire controller get wet. This may cause an electric shock or fire.
- Never press the buttons of the wire controller with a hard, pointed object. This may damage the wire controller.
- Never inspect or service the wire controller yourself, ask a qualified service person to do this.
- The wire controller must be installed inside the unit and is not allowed to be installed in other positions.

Feature and function of the wired controller

Feature:

- LCD display.
- Malfunction code display: it can display the error code, helpful for service.
- Weekly Timer.

Function:

- Turning the unit ON/OFF
- Operation mode change-over:
HEAT
DHW
HEAT and DHW
- Temp setting
- Weekly timer
- Turbo
- Child Lock
- LCD display
- Clock

The functions "HEAT" and "DHW" can only be selected when the corresponding equipment is installed.

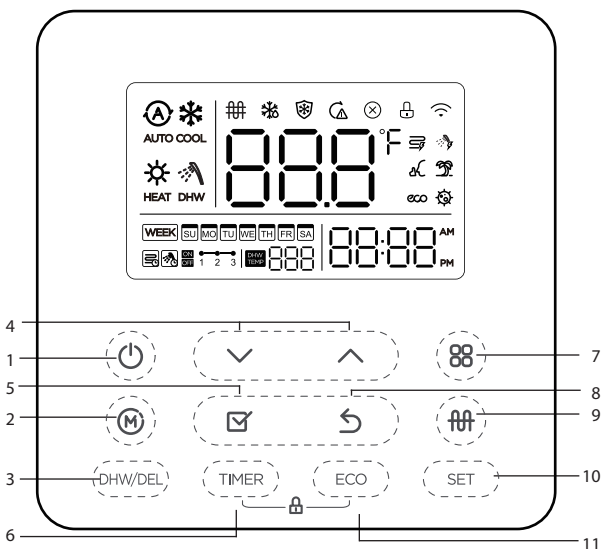

- | | |
|------------------|-------------------------------|
| 1 POWER button | 7 FUNC. button |
| 2 MODE button | 8 BACK button |
| 3 DHW/DEL button | 9 AUXILIARY ELECTRICAL button |
| 4 ADJUST button | 10 SET button |
| 5 CONFIRM button | 11 ECO button |
| 6 TIMER button | |

Name on the LCD of the wired controller

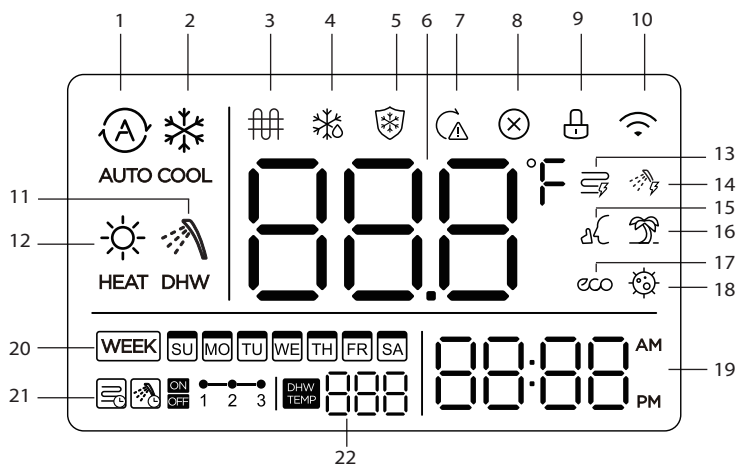

- 1 Auto mode indication
(Not applicable for this unit)
- 2 Cool mode indication
(Not applicable for this unit)
- 3 Electrical auxiliary heat indication
- 4 Defrost indication
- 5 Antifreeze status indication
- 6 Outlet water temperature display
- 7 Backup running status display
(Not applicable for this unit)
- 8 Invalid key prompt
- 9 Lock indication
- 10 Wifi indication
- 11 Domestic hot water
- 12 Heat mode indication
- 13 Turbo heating
- 14 Turbo domestic hot water
- 15 Mute
(Not applicable for this unit)
- 16 Outgoing function
- 17 Energy saving
- 18 Disinfection
- 19 Clock display
- 20 Weekly time
- 21 Refrigeration, heating, domestic hot water timing
- 22 Domestic hot water temperature

Preparatory operation

Set the current day and time

1. Press the Timer button for 2 seconds or more. The timer display will flash.



2. Press the button "∨" or "∧" to set the date. The selected date will flash.



3. The date setting is finished and the time setting is prepared after pressing Timer button or CONFIRM button or there is no pressing button in 10 seconds.



4. Press the button "∨" or "∧" to set the current time. Press repeatedly to adjust the current time in 1-minute increments. Press and hold to adjust the current time continuous.



ex. Monday 11:20

5. The setting is done after pressing CONFIRM button or there is no pressing button in 10 seconds.



6. Time scale selection

Press the buttons "TIMER" and "DHW/DEL" for 3 seconds will alternate the clock time display between the 12h&24h scale.



Operation

To start/stop operation

Press the Power button.



To set the operation mode

Operation mode setting

Press the Mode button to set the operation mode.



NOTE: When HEAT and DHW mode is selected, the system will heat alternate between heating hot water and domestic hot water.

Temperature setting

Press DHW key to enter the hot water setting temperature adjustment, press "∨" and "∧" to select the temperature.

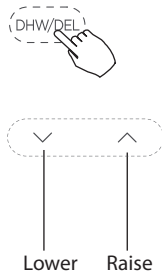

Setting Temperature Range : 35~55°C(95~131°F).

°C & °F scale selection

Press the buttons "∨" and "∧" for 3 seconds will alternate the temperature display between the °C & °F scale.

Child lock function

Press the buttons "TIMER" and "ECO" for 3 seconds to activate the child lock function and lock all buttons on the wire controller. Press the buttons again for 3 seconds to deactivate the child lock function. When the child lock function is activated, the  mark appears.



Energy saving button

(Effective in heating mode):

Press this button, the indoor unit operates in economy mode, press again, exit this mode (it may be ineffective for some models)



AUXILIARY ELECTRICAL HEATER function

Press this button to turn on or off the auxiliary electric heat function.



- Press this button, it is forced to turn on the electric auxiliary heating (the user has a turbo heating demand). Electric auxiliary heat is turned on when it meets the mandatory opening condition.
- Press Again, it is the electric auxiliary heat automatic control. Electric auxiliary heat is turned on at the most suitable time according to the control scheme, considering energy saving and comfort.

Set button:

Press SET button for 2 seconds to enter the query mode.



1. After entering the query mode, the time area at the lower right corner displays CL, indicating the cleaning function.

2. Press SET button to enter the setting interface, press "∨" and "∧" to select on or off, then press Confirm button to confirm, select on to indicate the cleaning function is turned on, at the same time, the interface will display CL.

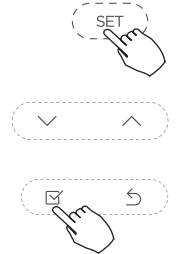

3. Press Power button or Back button to exit, or the internal machine finishes the cleaning function to exit.

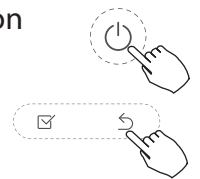

4. Press the buttons "∨" and "∧" can choose other parameter query.



- When FB is selected, it means the forced return function. Press set to enter the setting interface, and select whether to enable forced return. When on is selected, it means enabled.
- When CB is selected, it means the disinfection function. Press set to enter the setting interface, select whether to enable disinfection function. When On is selected, it means that it is on. After selecting ON, set the day of the week. After setting, press Confirm button to enter the time setting, and then press the Confirm button to confirm.

Select T: 01, it means TW_in temperature sensor for exchanger inlet water.

Select T: 02 it means TW_out temperature sensor for exchanger outlet water.

TW_Out heat exchanger.

Select T: 03, it means TW1 temperature sensor for outlet wate of hydraulic module.

Select T: 04, it means TR_out temperature sensor for refrigerant gas.

Select T: 05, it means TR_in temperature sensor for refrigerant liquid.

Select T: 06, it means Tk temperature sensor for water of water tank.

Select T: 07, it means TH temperature sensor for return water.

Select T: 08, it means TW1B temperature sensor for total outlet water.

Select T: 09, which means the outdoor T3 temperature.

Select T: 10, which means the outdoor T4 temperature.

Select PU: 11 to indicate the pump status.

Select Er: 12 for error codes.

5. From the last operation button 30 seconds after or press Back, switch to directly exit.

Timer functions

Press the Timer button for one second to set timing mode:

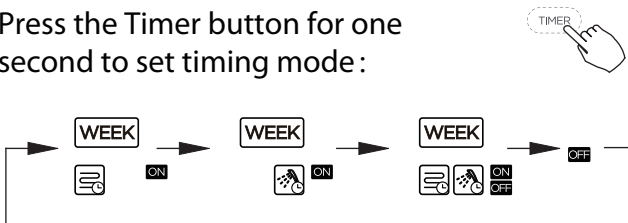

Weekly Timer

1. Weekly timer setting

Press the Timer button and then press the SET button to enter the Weekly timer setting.

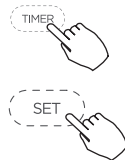

2. Day of the week setting

Press the button "∨" or "∧" to select the day of the week and then press the Confirm button to confirm the setting.

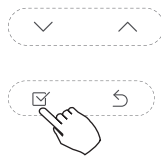

3. ON timer setting of timer setting

Press the button "∨" or "∧" to set the time of On timer and then press the Confirm button to confirm the setting.

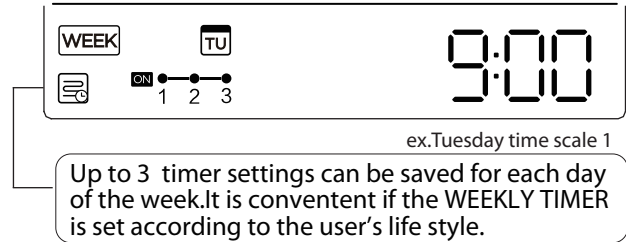
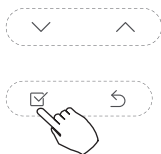

4. Off timer setting of timer setting

Press the button "∨" or "∧" to set the time of Off timer and then press the Confirm button to confirm the setting.

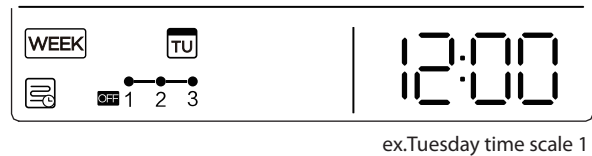
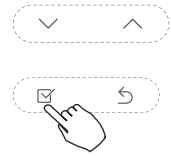

NOTE: The weekly timer setting can be returned to the previous step by pressing Back button. The time of timer setting can be delete by pressing Del button. The current setting will be restored and withdrawn the weekly timer setting automatically when there is no operation for 30 seconds.

WEEKLY timer operation

To activate WEEKLY TIMER operation Press the Timer button while WEEK is displayed on the LCD.

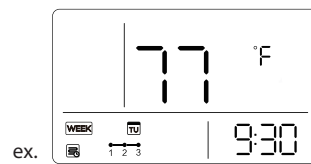

To deactivate WEEKLY TIMER operation

Press the Timer button while WEEK is disappear from the LCD.



To turn off the air conditioner during the weekly timer

1. If press the Power button once and quickly, the air conditioner will turn off temporarily. And the air conditioner will turn on automatically until the time of On timer.



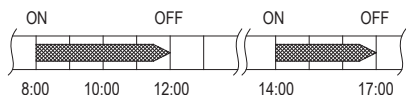

ex. If press the POWER button once and quickly at 10:00, The air conditioner will turn on at 14:00.

- When press the Power button for 2 seconds , the air conditioner will turn off completely, at the same time cancel the timing function.

FUNC. button

- Press the function key to select WLAN distribution network, turbo heating, turbo hot water, going out, disinfection (effective under shutdown) and other functions.
- Press the Confirm button to confirm.



WLAN

When the WLAN icon flashes, press the Confirm button to enter the AP distribution mode. If the AP mode is successfully entered, the LCD flashes the AP character. If the distribution network is not successful, the AP mode will exit automatically after 8 minutes. After the successful distribution network, if the network is connected, the WLAN icon will be on; if the network is disconnected for 15 minutes, the WLAN icon will be off.

Turbo Heating

In the HEAT mode or HEAT and DHW mode, press the FUNC. button to select the TurboHeating icon and press the Confirm button to turn on or off the Turbo Heating function. After the turbo heating function is turned on, the energy saving function is cancelled.

Turbo domestic hot water

In the DHW mode or HEAT and DHW mode, press the FUNC. button to select the Turbo domestic hot water icon and press the Confirm button to turn on or off the function.

Outgoing function

Press the FUNC. button to select the Outgoing function icon, and press the Confirm button to turn on or off the function.

After opening the out function, the set temperature of heating mode is 25 °C, and the set temperature of hot water mode is 35 °C. After canceling the out of office function, the set temperature will return to the original set temperature.

Energy saving

In the HEAT mode or HEAT and DHW mode, press the ECO button to select the Energy saving icon and press the Confirm button to turn on or off the function.

After the energy saving function is turned on, the turbo heating function is cancelled.

Disinfection

Under DHW mode or HEAT and DHW mode, press the FUNC. button to select the disinfection icon, press the Confirm button to turn on or off the disinfection function.

Fault alarm handling

If the system does not properly operate except the above mentioned cases or the above mentioned malfunctions is evident, investigate the system according to the following procedures.

NO.	MALFUNCTION & PROTECTION DEFINE	DISPLAY DIGITAL TUBE
1	Error of communication between wire controler and indoor unit	Eh63

The error displayed on the wire controller are different from those on the unit. If error code appears, please check the <<Owner's And Installation Manual>> and <<SERVICE Manual>>.

Technical indication and requirement

EMC and EMI comply with the CE certification requirements.

Care and Maintenance

Cleaning Your Unit

BEFORE CLEANING OR MAINTENANCE

ALWAYS TURN OFF YOUR AIR CONDITIONER SYSTEM AND DISCONNECT ITS POWER SUPPLY BEFORE CLEANING OR MAINTENANCE.

WARNING: DO NOT REMOVE OR CLEAN THE UNIT BY YOURSELF

Removing and cleaning the unit can be dangerous. Removal and maintenance must be performed by a certified technician.

CAUTION

Only use a soft, dry cloth to wipe the unit clean. If the unit is especially dirty, you can use a cloth soaked in warm water to wipe it clean.

- Do not use chemicals or chemically treated cloths to clean the unit
- Do not use benzene, paint thinner, polishing powder or other solvents to clean the unit. They can cause the plastic surface to crack or deform.
- Do not use water hotter than 40°C (104°F) to clean the front panel. This can cause the panel to deform or become discolored.
- Before cleaning the filter, close the water pipe externally connected to the hydraulic module, drain the water, unscrew the Y-type filter, and pull out the filter.
- Some metal edges and evaporator fins are sharp and improper operation may cause injury, so be careful when cleaning these parts.
- The maximum water pressure is 3 bar, but the best pressure range is between 1 to 2 bar. It will be perfect, if the water pressure is the same as pre-pressure of expansion vessel.

NOTE: The hydraulic module has no separate sewage outlet.

CAUTION

- Any maintenance and cleaning of outdoor unit should be performed by an authorized dealer or a licensed service provider.
- Any unit repairs should be performed by an authorized dealer or a licensed service provider.

Maintenance

In order to ensure optimal availability of the unit, a number of checks and inspections on the unit and the field wiring have to be carried out at regular intervals.

The described checks must be executed at least once a year:

- Water pressure
When the pointer of the water pressure gauge is in the red area or check if the water pressure is above 0.5 bar. If necessary add water.
- Water filter
Clean the water filter.
- Water pressure relief valve
Check for correct operation of the pressure relief valve by turning the red knob along the valve counter-clockwise:
 1. If you do not hear a clacking sound, contact your local dealer.
 2. In case the water keeps running out of the unit, close both the water inlet and outlet shut-off valves first and then contact your local dealer.
- Pressure relief valve hose
Check that the pressure relief valve hose is positioned appropriately to drain the water. If the drain pan kit is installed, make sure that the pressure relief valve hose end is positioned in the drain pan.

- Auxiliary heater vessel insulation cover
Check that the auxiliary heater insulation cover is fastened tightly around the auxiliary heater vessel.
- Indoor unit control box
 1. Carry out a through visual inspection of the control box and look for obvious defects such as loose connections or defective wiring.
 2. Check for correct operation of contactors by the use of an ohmmeter. All of these contactors must be in open position.

NOTE:

1. Regular cleaning and maintenance is required, otherwise it may the failure rate and shorten the service life. Effective cleaning and maintenance can not only remove the dust in the machine, extend the service life, but also reduce the power consumption of the system.
2. According to the local winter climate and installation location, it is necessary to determine whether to drain the water in the water module to prevent the water module from frost cracking.
3. The unit must be powered uninterruptedly to ensure the normal operation of anti freezing function. It is forbidden to close the valve on the hot water side and the stop valve on the pipeline on the air conditioning side to prevent blocking the operation of anti freezing function. In case of power failure or long-term non use, the water in the pipeline and heat exchanger must be drained.

Troubleshooting



SAFETY PRECAUTIONS

If any of the following conditions occurs, turn off your unit immediately!

- The power cord is damaged or abnormally warm
- You smell a burning odor
- The unit emits loud or abnormal sounds
- A power fuse blows or the circuit breaker frequently trips
- Water or other objects fall into or out of the unit

DO NOT ATTEMPT TO FIX THESE YOURSELF! CONTACT AN AUTHORIZED SERVICE PROVIDER IMMEDIATELY!

Common Issues

The following problems are not a malfunction and in most situations will not require repairs.

Issue	Possible Causes
The indoor unit makes noises	Water system has air and needs to be evacuated.
	Water pump abnormal.

Troubleshooting

When troubles occur, please check the following points before contacting a repair company.

Problem	Possible Causes	Solution
The unit is not working	Power failure	Wait for the power to be restored
	The power is turned off	Turn on the power
	The fuse is burned out	Replace the fuse
	Wired controller batteries are dead	Replace battery
	The Unit's 3-minute protection has been activated	Wait three minutes after restarting the unit
The unit starts and stops frequently	There's too much or too little refrigerant in the system	Check for leaks and recharge the system with refrigerant.
	Incompressible gas or moisture has entered the system.	Evacuate and recharge the system with refrigerant
	System circuit is blocked	Determine which circuit is blocked and replace the malfunctioning piece of equipment
	The compressor is broken	Replace the compressor
	The voltage is too high or too low	Install a manostat to regulate the voltage
Poor heating performance	The outdoor temperature is extremely low	Use auxiliary heating device
	Cold air is entering through doors and windows	Make sure that all doors and windows are closed during use
	Low refrigerant due to leak or long-term use	Check for leaks, re-seal if necessary and top off refrigerant









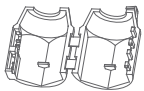

NOTE: If problem persists, contact a local dealer or your nearest customer service center. Provide them with a detailed description of the unit malfunction as well as your model number.

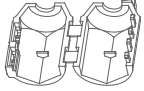
Error Codes

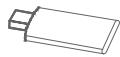
Number	Cause	Ordinary mode	Engineering mode	Error Code
1	Indoor EEPROM error	Yes	Yes	Eh00
2	Indoor and outdoor unit communication malfunction	Yes	Yes	EL0 1
3	Outdoor EEPROM error	Yes	Yes	Ec51
4	Outdoor condenser pipe sensor error	Yes	Yes	Ec52
5	Outdoor temperature sensor error	Yes	Yes	Ec53
6	Discharge air temperature sensor error	Yes	Yes	Ec54
7	T2b sensor error	Yes	Yes	Ec56
8	Outdoor IGBT sensor error	Yes	Yes	Ec55
9	Water flow failure	Yes	Yes	Eh40
10	TW_in sensor error	Yes	Yes	Eh41
11	TW_out sensor error	Yes	Yes	Eh42
12	TW1 sensor error	Yes	Yes	Eh43
13	TR_Out sensor error	Yes	Yes	Eh44
14	TR_In sensor error	Yes	Yes	Eh45
15	TK sensor error	Yes	Yes	Eh46
16	TWH sensor error	Yes	Yes	Eh47
17	TW1B sensor error	Yes	Yes	Eh48
18	Shedding protection of water temperature sensor in and out of heat exchanger	Yes	Yes	Eh49
19	Outdoor fan speed malfunction	Yes	Yes	EC07
20	IPM module error	Yes	Yes	PC00
21	High/Low voltage protection	Yes	Yes	PC01
22	Compressor top overheating protec	Yes	Yes	PC02
23	Compressor drive error	Yes	Yes	PC04
24	TW1 high temperature protection	NO	Yes	PC61
25	Outdoor current protection	NO	Yes	PC08
26	Compressor low-pressure protection	Yes	Yes	PC03
27	One drag multiple warm and cold mode conflict	Yes	Yes	-----

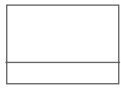
Accessories

The air conditioning system comes with the following accessories. Use all of the installation parts and accessories to install the air conditioner. Improper installation may result in water leakage, electrical shock and fire, or cause the equipment to fail. The items are not included with the air conditioner must be purchased separately.

Name of Accessories	Q'ty(pc)	Shape	Name of Accessories	Q'ty(pc)	Shape
Manual	3		3/4 Copper nut anti disassembly cap	1	
Mounting bracket	1		7/16 Copper nut anti disassembly cap	1	
3/4 Copper nut	1		Smart kit	1	
7/16 Copper nut	1		WLAN cable	1	
Label NOTE:Please stick the label to the power switch of the unit	1		WLAN rubber sleeve	1	
Wiring rubber ring	1		Battery	1	

Name	Shape	Quantity(PC)
Connecting pipe assembly	Liquid side	$\Phi 6.35(1/4\text{in})$
	Gas side	$\Phi 12.7(1/2\text{in})$
	Flow connection from heat pump	$\Phi 28$
Parts you must purchase separately. Consult the dealer about the proper pipe size of the unit you purchased.		

Installation Summary

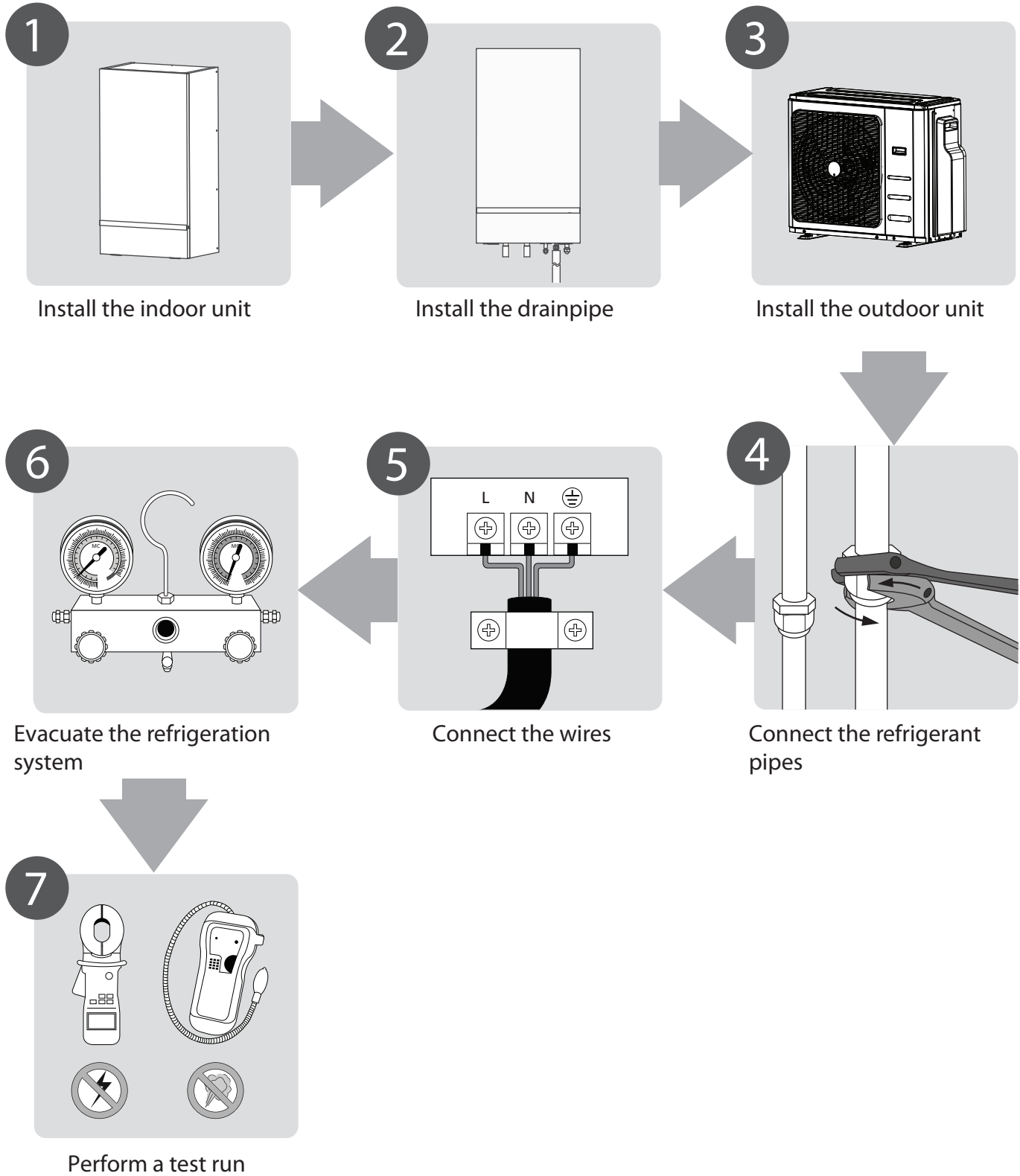

Installation Summary

Unit Parts

NOTE: The installation must be performed in accordance with the requirement of local and national standards. The installation may be slightly different in different areas. The application examples given below are for illustration purposes only.

(A) Usage scenario : Auxiliary heat source

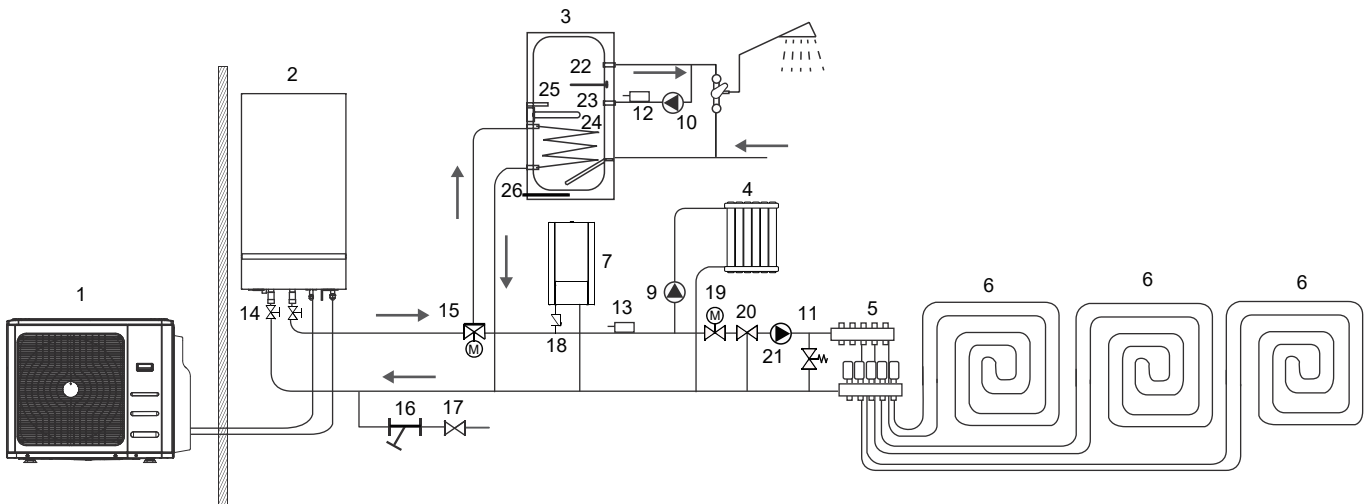

(B) Usage scenario : Pipeline auxiliary electric heating

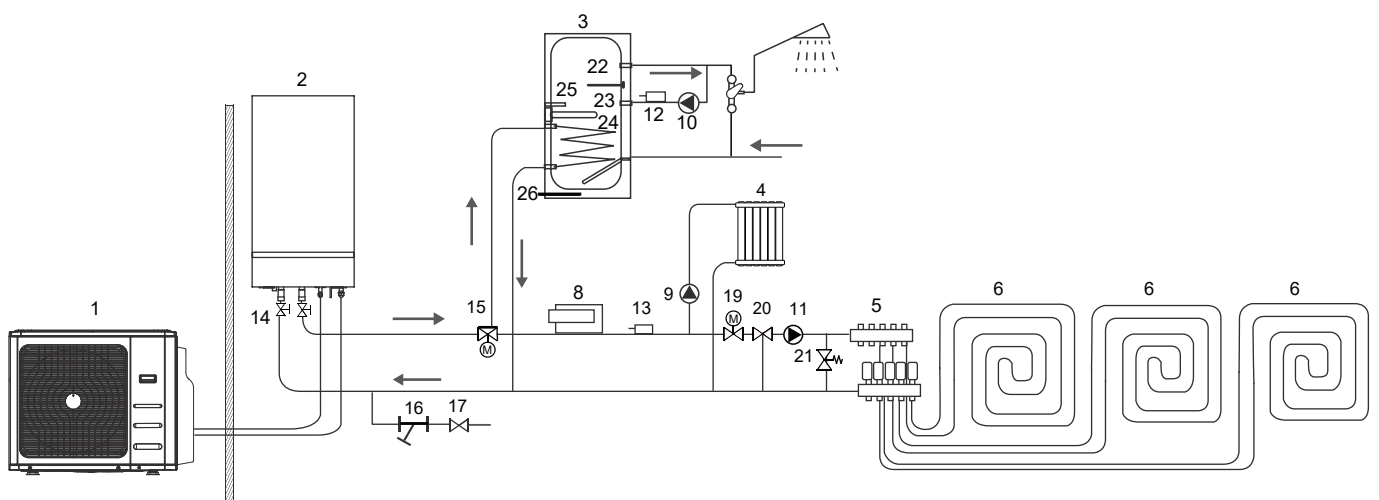

NOTE ON ILLUSTRATIONS

Illustrations in this manual are for explanatory purposes. The actual shape of your indoor unit may be slightly different. The actual shape shall prevail.

1. Outdoor unit
2. Indoor unit
3. Domestic hot water storage tank
4. Radiator
5. Water separator
6. Floor heating
7. Auxiliary heat source
If the unit selection is too small, additional heat is provided.
8. Pipeline auxiliary electric heating
If the unit selection is too small, additional heat is provided.
9. External circulating water pump
When the water resistance is greater than the head provided by the internal machine, the pump shall be added to the branch with excessive water resistance.
10. Backwater pump
Control the pump switch through the back-water temperature-sensing package to keep hot water at any time.
11. Mixing water pump
With the water mixing valve, lower the temperature of the floor heating, and do not install it when there is no radiator.
12. Return water temperature sensing bag
Control the operation of return water pump and keep hot water available at any time.
13. Heating water supply main pipe temperature sensing package
Work with external heat source 7 or 8.
14. Globe valve
Close water flow for maintenance.
15. Electric three-way valve
Used for switching between heating and domestic hot water mode, working with domestic hot water tank.
16. Filter
Water supply system, filter impurities.
17. Differential pressure make-up valve
Adjust the system water pressure to ensure that it is in the normal working range.
18. Check valve
To prevent the internal machine water supply from flowing back into the external heat source 7, this valve is not needed for electric pipeline heating.
19. Electric two-way valve
Not available - not used.
20. Mixing valve
Used with mixed water pump.
21. Differential pressure bypass valve
In the case of multiple branch water closure, bypass water flow to ensure sufficient water flow to prevent water flow failure.
22. Anode magnesium rod
Improve corrosion resistance, need to be replaced regularly.
23. Electric immersion heater
Used for auxiliary heating and sterilization.
24. Heating coil
Heat the water in the water tank to isolate the heating water.
25. Temperature probe tube
Place a water tank temperature sensing package to control the temperature of domestic hot water.
26. Sewage outlet
used for water tank cleaning.

NOTE: In addition to the outdoor unit and indoor unit, other materials are prepared by users.
22-26 is an indispensable part of domestic hot water tank.

Functional diagram

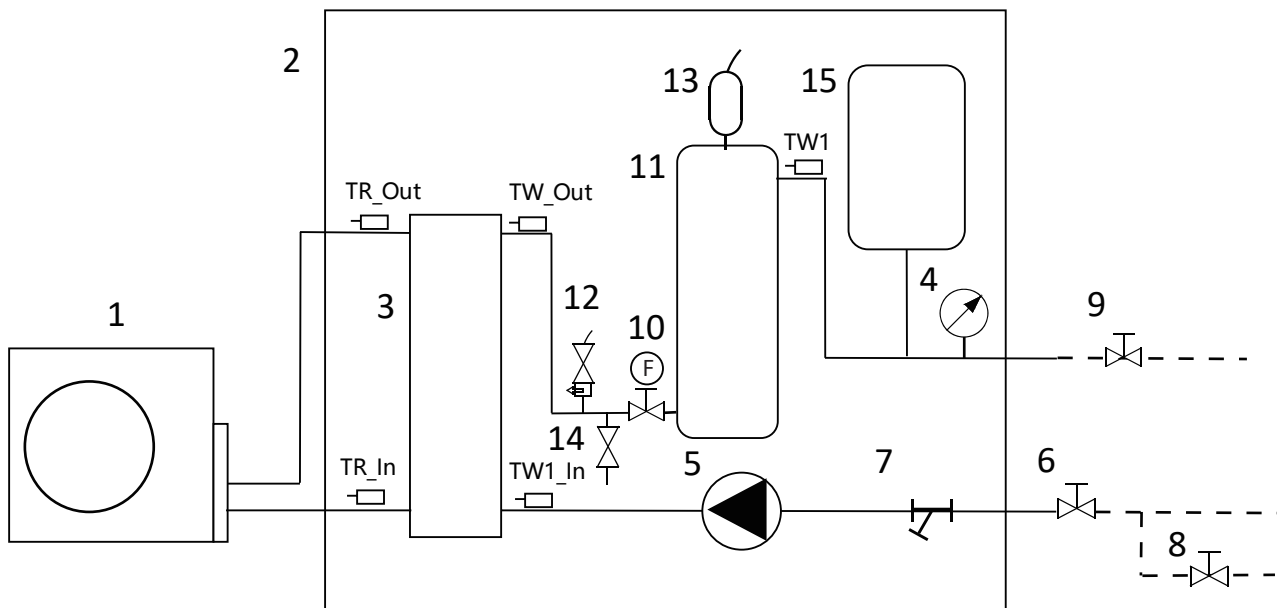

- | | |
|--|--|
| 1. Outdoor unit | 9. Shut-off valve |
| 2. Indoor unit | 10. Flow switch |
| 3. Refrigerant to water heat exchanger | 11. Auxiliary heater vessel
(Separate power supply) |
| 4. Manometer | 12. Pressure relieve valve |
| 5. Pump | 13. Automatic air purge valve |
| 6. Shut-off valve | 14. Drain valve |
| 7. Filter | 15. Expansion vessel |
| 8. Auto-water replenishing | |

Indoor Unit Installation

Installation Instructions – Indoor unit

⚠ CAUTION

The indoor unit should be installed in a water proof place, or the safety of the unit and the operator cannot be ensured.

Step 1: Select installation location

- ☑ The indoor unit is to be wall mounted in an indoor location that meets the following requirements:
- ☑ The installation location is frost-free.
- ☑ The space around the unit is adequate for serving.
- ☑ The space around the unit allows for sufficient air circulation.
- ☑ There is a provision for condensate drain and pressure relief valve blow-off.
- ☑ The installation surface is a flat and vertical non-combustible wall, capable of supporting the operation weight of the unit.
- ☑ There is no danger of fire due to leakage of inflammable gas.
- ☑ The equipment is not intended for use in a potentially explosive atmosphere.

Inspecting, handling and unpacking the unit

The indoor unit is packed in a box.

At delivery, the unit must be checked and any damage must be reported immediately to the carrier claims agent.

Check if all indoor unit accessories are enclosed. Bring the unit as close as possible to the final installation position in its original package in order to prevent damage during transport.

- The indoor unit weights approximately 60kg and should be lifted by two persons using the two lifting bars provided.

⚠ WARNING

Do not grasp the control box or piping to lift the unit! Two lifting bars are provided to lift the unit.

Step 2: Dimensions and service space

Unit of measurement: mm

Dimensions of the wall bracket:

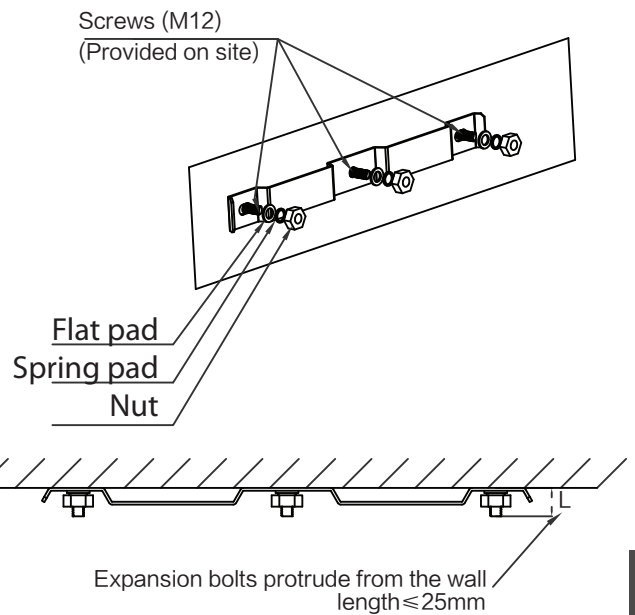
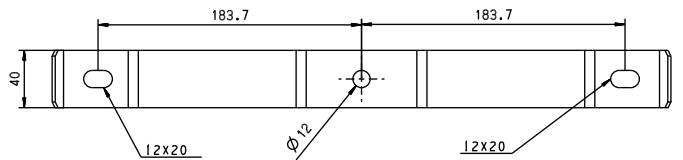

Dimensions of the unit.

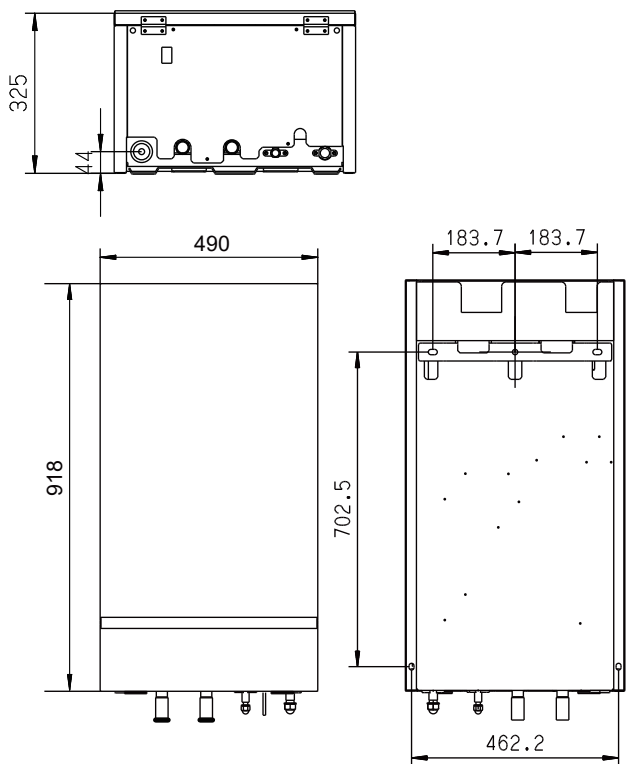

Required service space

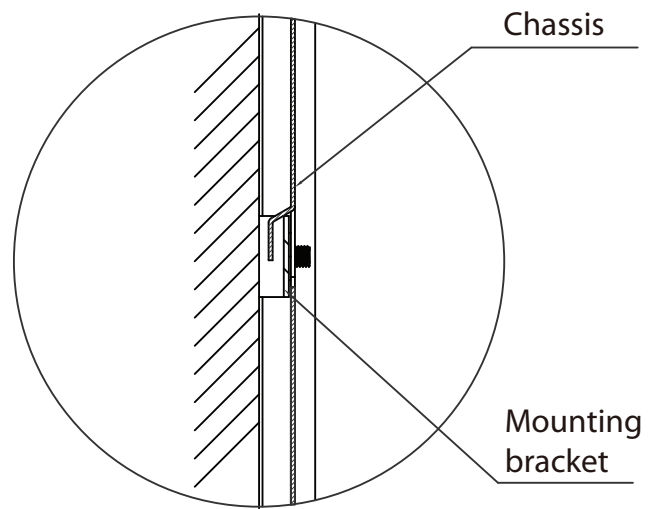
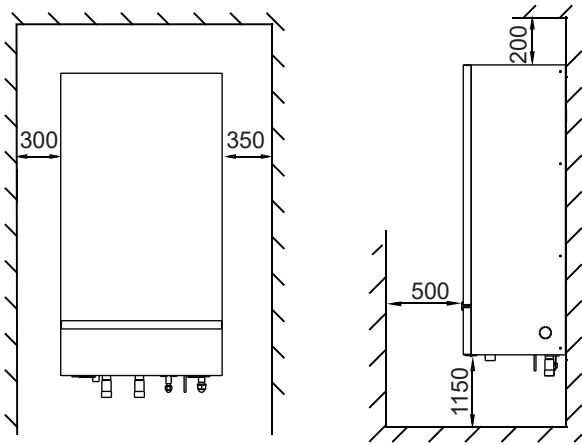

Step 3: Mounting the indoor unit

WARNING

The weight of the indoor unit is heavy . Two persons are required to mount the unit.

- Fix the wall mounting bracket to the wall using appropriate plugs and screws.
- Make sure the wall mounting bracket is completely level.
When the unit is not installed level, air might get trapped in the water circuit resulting in malfunctioning of the unit.
- Hang the indoor unit on the wall mounting bracket.
- Fix the indoor unit inside using appropriate plugs and screw.

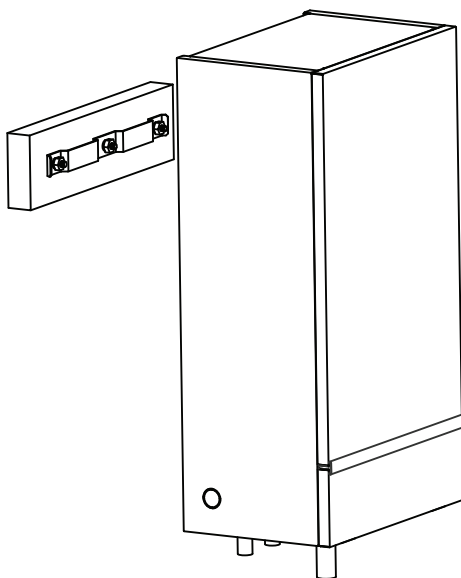

Step 4: Water filling and anti freezing measures

Water filling and emptying

- Before the hydraulic module is connected to the water pipeline, please check the water resistance of the connected user water system. If the water resistance exceeds 40KPa, please increase the external circulation pump in the total change or the branch with large water resistance. If a mixed water pump has been installed in the floor heating branch, there is no need to add a circulating water pump in this branch.
- For the first operation, it is recommended to rotate the pump shaft for more than 10 turns to prevent the pump from getting stuck.
- Exhaust valve shall be set at the highest point and local highest point of water system pipeline, and drain valve shall be set at the lowest point.
- After the indoor unit and outdoor unit are installed, confirm that the power supply is closed, loosen the vent valve on the indoor unit, and inject water into the water system of indoor unit.
- Check the water system for leaks.
- If there is no leakage in the system pipeline, the power supply of the unit will enter the emptying mode of the wire controller to carry out the forced operation of the water pump. Remove air in the circuit as much as possible using the air purge valves.

When there is no "hissing" pneumatic sound at the vent valve, close the vent valve on the indoor unit and exit the forced water pump.

- Fill with water until the manometer indicates a pressure of approximately 1.0~2.0 bar.

Antifreezing measures

- When the ambient temperature is below 2 °C, please make sure to keep the unit energized.
- If the unit cannot be powered on, please open the drain valve in the indoor unit to completely drain the water to avoid freezing and cracking the equipment and pipes.
- All pipelines in the user's water system that may be below the ambient temperature of 2 °C must be insulated.

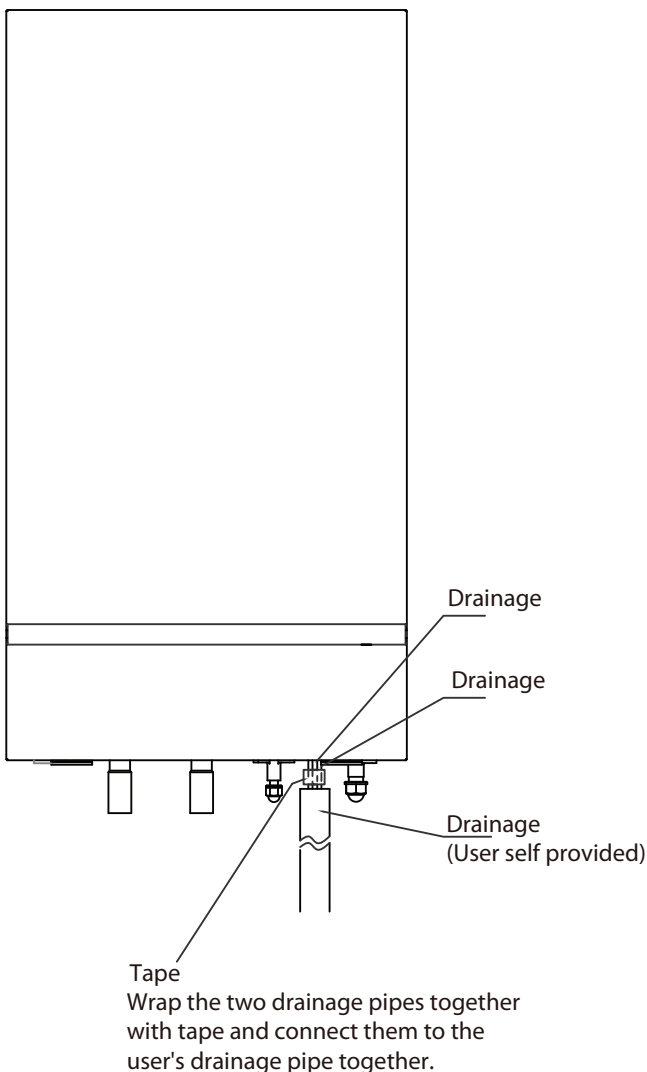

Step 5: Description of water pump exhaust

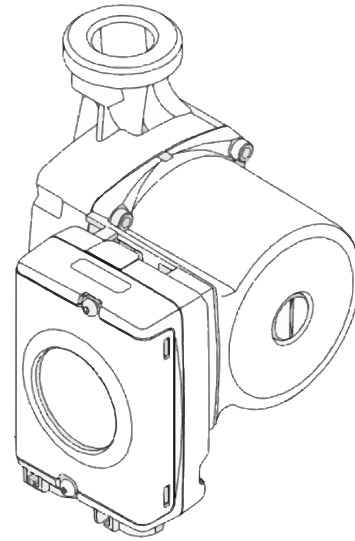

1. Make sure the water pump is running.
2. Insert the service tool into the slot of the bleeder bolt and remove the bleeder bolt.
3. When the small water column or water drop flows out of the vent hole, screw on the vent bolt.

NOTE: The water pressure of the system must be guaranteed, and it cannot be directly connected to the water source.

Indoor Drainpipe Installation

- It must be confirmed that the drainpipe outlet is exposed in the air. When flexible drainpipe is jointed to the drainpipe of the hydraulic module, it must be confirmed that the flexible drainpipe is downwards vertically, direct drainage to the floor drain.
- The drainage pipe should be well installed, in order to avoid freezing up in cold weather. Do not block off or bend the Drainage pipe.
- Arrange the drain hose to ensure smooth drainpipe. Improper drainpipe may cause wetting of the building, furniture etc.

Outdoor Unit Installation

Install the unit by following local codes and regulations, there may be differ slightly between different regions.

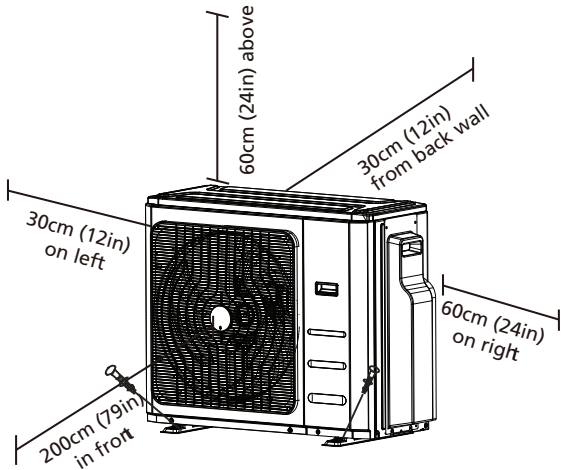

Installation Instructions – Outdoor unit

Step 1: Select installation location

Before installing the outdoor unit, you must choose an appropriate location. The following are standards that will help you choose an appropriate location for the unit.

Proper installation locations meet the following standards:

- Meets all spatial requirements shown in Installation Space Requirements above.
- Good air circulation and ventilation
- Firm and solid—the location can support the unit and will not vibrate
- Noise from the unit will not disturb others
- Protected from prolonged periods of direct sunlight or rain
- Where snowfall is anticipated, raise the unit above the base pad to prevent ice buildup and coil damage. Mount the unit high enough to be above the average accumulated area snowfall. The minimum height must be 18 inches

DO NOT install unit in the following locations:

- Near an obstacle that will block air inlets and outlets
- Near a public street, crowded areas, or where noise from the unit will disturb others
- Near animals or plants that will be harmed by hot air discharge
- Near any source of combustible gas
- In a location that is exposed to large amounts of dust
- In a location exposed to a excessive amounts of salty air

SPECIAL CONSIDERATIONS FOR EXTREME WEATHER

If the unit is exposed to heavy wind:

Install unit so that air outlet fan is at a 90° angle to the direction of the wind. If needed, build a barrier in front of the unit to protect it from extremely heavy winds. See Figures below.

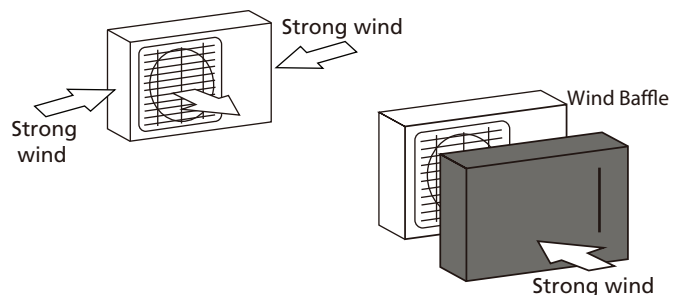

If the unit is frequently exposed to heavy rain or snow:

Build a shelter above the unit to protect it from the rain or snow. Be careful not to obstruct air flow around the unit.

If the unit is frequently exposed to salty air (seaside):

Use outdoor unit that is specially designed to resist corrosion.

Step 2: Install drain joint (Heat pump unit only)

Before bolting the outdoor unit in place, you must install the drain joint at the bottom of the unit. Note that there are two different types of drain joints depending on the type of outdoor unit.

If the drain joint comes with a rubber seal (see Fig. A), do the following:

1. Fit the rubber seal on the end of the drain joint that will connect to the outdoor unit.
2. Insert the drain joint into the hole in the base pan of the unit.
3. Rotate the drain joint 90° until it clicks in place facing the front of the unit.
4. Connect a drain hose extension (not included) to the drain joint to redirect water from the unit during heating mode.

If the drain joint doesn't come with a rubber seal (see Fig. B), do the following:

1. Insert the drain joint into the hole in the base pan of the unit. The drain joint will click in place.
2. Connect a drain hose extension (not included) to the drain joint to redirect water from the unit during heating mode.

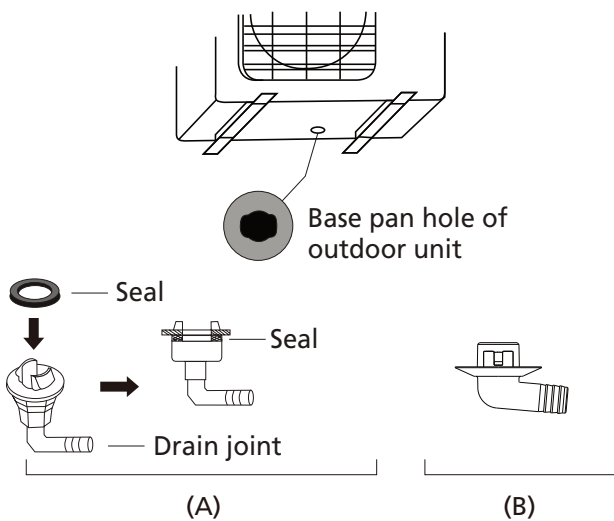

Step 3: Anchor outdoor unit

The outdoor unit can be anchored to the ground or to a wall-mounted bracket with bolt(M10). Prepare the installation base of the unit according to the dimensions below.

UNIT MOUNTING DIMENSIONS

The following is a list of different outdoor unit sizes and the distance between their mounting feet. Prepare the installation base of the unit according to the dimensions below.

Outdoor Unit Types and Specifications

Split Type Outdoor Unit

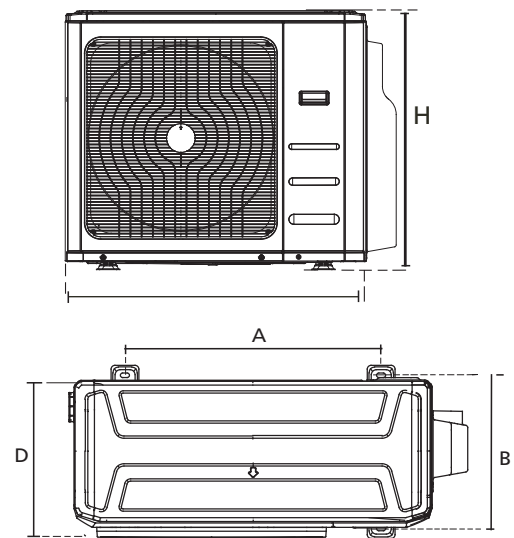

(unit: mm/inch)

Outdoor Unit Dimensions W x H x D	Mounting Dimensions	
	Distance A	Distance B
946x810x410 (37.24x31.9x16.14)	673 (26.5)	403 (15.87)

! IN COLD CLIMATES

In cold climates, make sure that the drain hose is as vertical as possible to ensure swift water drainage. If water drains too slowly, it can freeze in the hose and flood the unit.

Rows of series installation

The relations between H, A and L are as follows.

	L	A
$L \leq H$	$L \leq 1/2H$	25 cm / 9.8" or more
	$1/2H < L \leq H$	30 cm / 11.8" or more
$L > H$	Can not be installed	

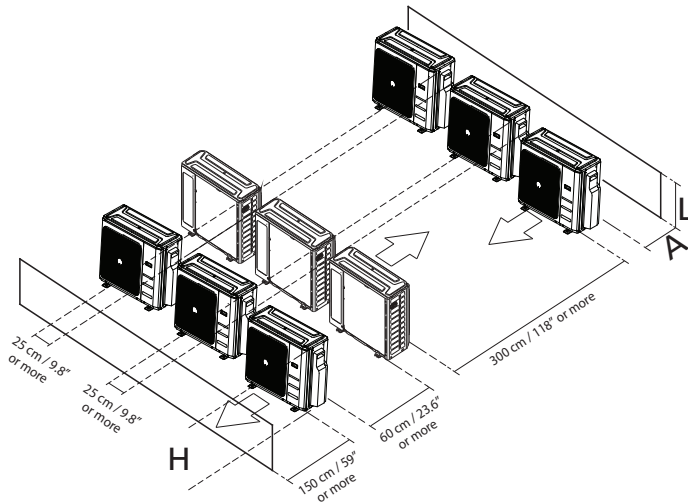

Refrigerant Piping Connection

When connecting refrigerant piping, do not let substances or gases other than the specified refrigerant enter the unit. The presence of other gases or substances will lower the unit's capacity, and can cause abnormally high pressure in the refrigeration cycle. This can cause explosion and injury.

Note on Pipe Length

Ensure that the length of the refrigerant pipe, the number of bends, and the drop height between the indoor and outdoor units meets the requirements shown in the following table :

The Maximum Length And Drop Height Based on Models. (Unit: m/ft.)

Type of model	Capacity (Btu/h)	Length of piping	Maximum drop height
North America, Australia and the eu frequency conversion Split Type	<15K	25/82	10/32.8
	≥15K - <24K	30/98.4	20/65.6
	≥24K - <36K	50/164	25/82
	≥36K - ≤60K	65/213	30/98.4
Other Split Type	12K	15/49	8/26
	18K-24K	25/82	15/49
	30K-36K	30/98.4	20/65.6
	42K-60K	50/164	30/98.4

⚠ CAUTION

- Oil traps
If the indoor unit is installed higher than the outdoor unit:
-If oil flows back into the outdoor unit's compressor, this might cause liquid compression or deterioration of oil return. Oil traps in the rising gas piping can prevent this.
An oil trap should be installed every 10m (32.8ft) of vertical suction line riser.

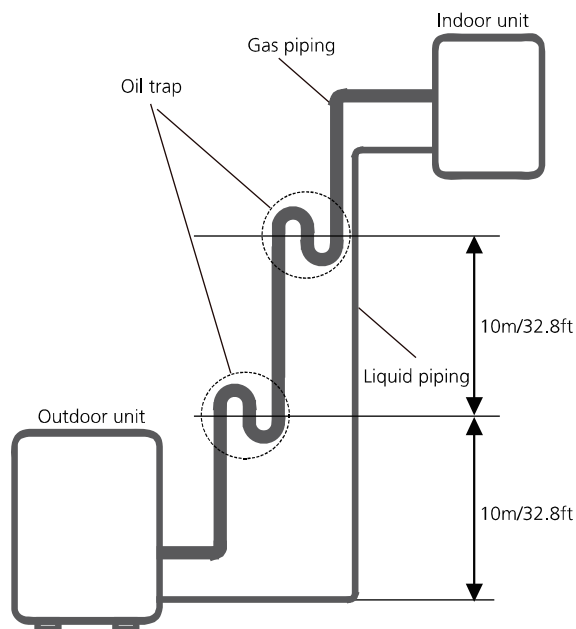

The indoor unit is installed higher than the outdoor unit

⚠ CAUTION

If the outdoor unit is installed higher than the indoor unit:

-It is recommended that vertical suction risers not be upsized. Proper oil return to the compressor should be maintained with suction gas velocity. If velocities drop below 7.62m/s (1500fpm (feet per minute)), oil return will be decreased. An oil trap should be installed every 6m(20ft) of vertical suction line riser.

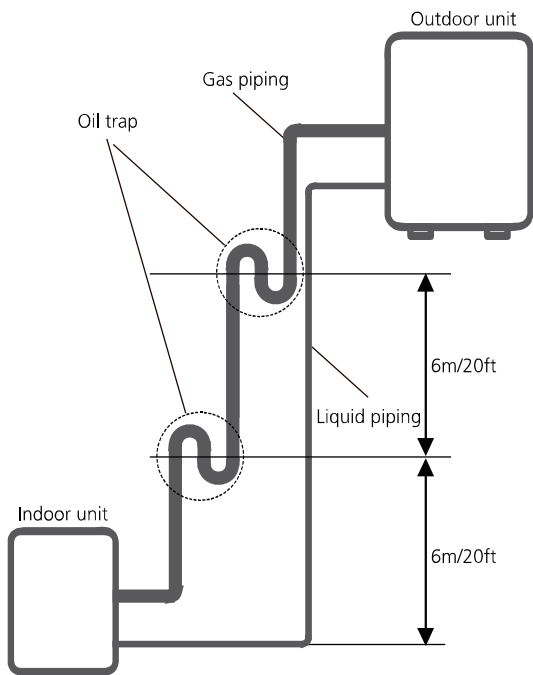

The outdoor unit is installed higher than the indoor unit

Step 1: Cut pipes

When preparing refrigerant pipes, take extra care to cut and flare them properly. This will ensure efficient operation and minimize the need for future maintenance.

1. Measure the distance between the indoor and outdoor units.
2. Using a pipe cutter, cut the pipe a little longer than the measured distance.
3. Make sure that the pipe is cut at a perfect 90° angle.

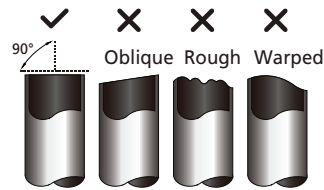

⊘ DO NOT DEFORM PIPE WHILE CUTTING

Be extra careful not to damage, dent, or deform the pipe while cutting. This will drastically reduce the heating efficiency of the unit.

Step 2: Remove burrs

Burrs can affect the air-tight seal of refrigerant piping connection. They must be completely removed.

1. Hold the pipe at a downward angle to prevent burrs from falling into the pipe.
2. Using a reamer or deburring tool, remove all burrs from the cut section of the pipe.

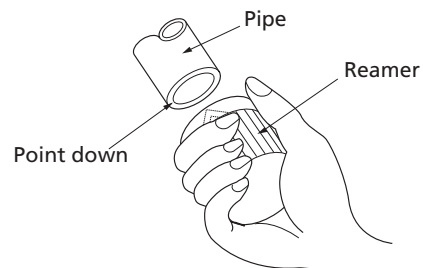

Connection Instructions – Refrigerant Piping

⚠ CAUTION

- The branching pipe must be installed horizontally. An angle of more than 10° may cause malfunction.
- **DO NOT** install the connecting pipe until both indoor and outdoor units have been installed.
- Insulate both the gas and liquid piping to prevent water leakage.

Step 3: Flare pipe ends

Proper flaring is essential to achieve an airtight seal.

1. After removing burrs from cut pipe, seal the ends with PVC tape to prevent foreign materials from entering the pipe.
2. Sheath the pipe with insulating material.
3. Place flare nuts on both ends of pipe. Make sure they are facing in the right direction, because you can't put them on or change their direction after flaring.

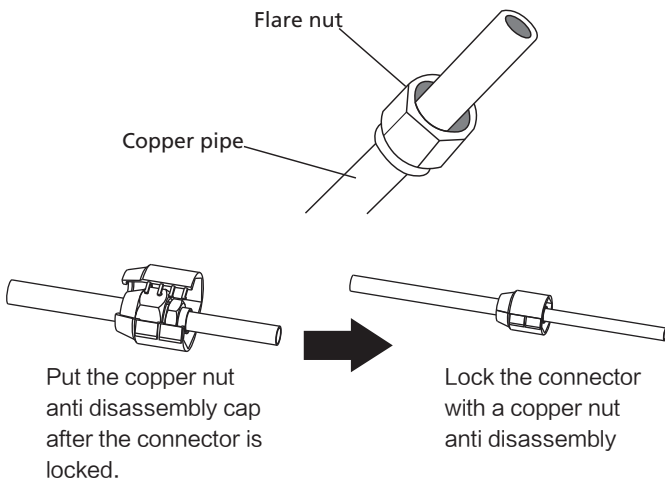

4. Remove PVC tape from ends of pipe when ready to perform flaring work.
5. Clamp flare form on the end of the pipe. The end of the pipe must extend beyond the flare form.

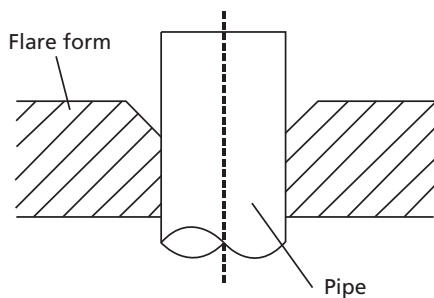

6. Place flaring tool onto the form.
7. Turn the handle of the flaring tool clockwise until the pipe is fully flared. Flare the pipe in accordance with the dimensions.

PIPING EXTENSION BEYOND FLARE FORM

Pipe gauge	Tightening torque	Flare dimension (A) (Unit: mm/Inch)		Flare shape
		Min.	Max .	
Ø 6.35	18-20 N.m (183-204 kgf.cm)	8.4/0.33	8.7/0.34	
Ø 9.52	25-26 N.m (255-265 kgf.cm)	13.2/0.52	13.5/0.53	
Ø 12.7	35-36 N.m (357-367 kgf.cm)	16.2/0.64	16.5/0.65	
Ø 16	45-47 N.m (459-480 kgf.cm)	19.2/0.76	19.7/0.78	
Ø 19	65-67 N.m (663-683 kgf.cm)	23.2/0.91	23.7/0.93	
Ø 22	75-85 N.m (765-867 kgf.cm)	26.4/1.04	26.9/1.06	

8. Remove the flaring tool and flare form, then inspect the end of the pipe for cracks and even flaring.

Step 4: Connect pipes

Connect the copper pipes to the indoor unit first, then connect it to the outdoor unit. You should first connect the low-pressure pipe, then the high-pressure pipe.

1. When connecting the flare nuts, apply a thin coat of refrigeration oil to the flared ends of the pipes.
2. Align the center of the two pipes that you will connect.

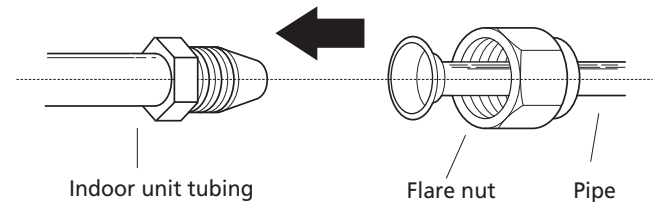

3. Tighten the flare nut as tightly as possible by hand.
4. Using a spanner, grip the nut on the unit tubing.
5. While firmly gripping the nut, use a torque wrench to tighten the flare nut according to the torque values in above table.

NOTE: Use both a spanner and a torque wrench when connecting or disconnecting pipes to/from the unit.

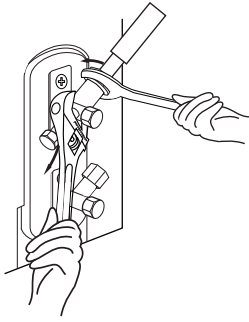

! CAUTION

- Ensure to wrap insulation around the piping. Direct contact with the bare piping may result in burns or frostbite.
- Make sure the pipe is properly connected. Over tightening may damage the bell mouth and under tightening may lead to leakage.

NOTE ON MINIMUM BEND RADIUS

Carefully bend the tubing in the middle according to the diagram below. **DO NOT** bend the tubing more than 90° or more than 3 times.

Bend the pipe with thumb



min-radius 10cm (3.9")

6. After connecting the copper pipes to the indoor unit, wrap the power cable, signal cable and the piping together with binding tape.

NOTE: **DO NOT** intertwine signal cable with other wires. While bundling these items together, do not intertwine or cross the signal cable with any other wiring.

7. Thread this pipeline through the wall and connect it to the outdoor unit.
8. Insulate all the piping, including the valves of the outdoor unit.
9. Open the stop valves of the outdoor unit to start the flow of the refrigerant between the indoor and outdoor unit.

! CAUTION

Check to make sure there is no refrigerant leak after completing the installation work. If there is a refrigerant leak, ventilate the area immediately and evacuate the system (refer to the Air Evacuation section of this manual).

Wiring

BEFORE PERFORMING ANY ELECTRICAL WORK, READ THESE REGULATIONS

1. All wiring must comply with local and national electrical codes, regulations and must be installed by a licensed electrician.
2. All electrical connections must be made according to the Electrical Connection Diagram located on the panels of the indoor and outdoor units.
3. If there is a serious safety issue with the power supply, stop work immediately. Explain your reasoning to the client, and refuse to install the unit until the safety issue is properly resolved.
4. Power voltage should be within 90-110% of rated voltage. Insufficient power supply can cause malfunction, electrical shock, or fire.
5. If connecting power to fixed wiring, install a surge protector and main power switch with a capacity of 1.5 times the maximum current of the unit.
6. If connecting power to fixed wiring, a switch or circuit breaker that disconnects all poles and has a contact separation of at least 1/8in (3mm) must be incorporated in the fixed wiring. The qualified technician must use an approved circuit breaker or switch.
7. Only connect the unit to an individual branch circuit outlet. Do not connect another appliance to that outlet.
8. Make sure to properly ground the air conditioner.
9. Every wire must be firmly connected. Loose wiring can cause the terminal to overheat, resulting in product malfunction and possible fire.
10. Do not let wires touch or rest against refrigerant tubing, the compressor, or any moving parts within the unit.

11. If the unit has an auxiliary electric heater, it must be installed at least 1 meter (40in) away from any combustible materials.
12. To avoid getting an electric shock, never touch the electrical components soon after the power supply has been turned off. After turning off the power, always wait 10 minutes or more before you touch the electrical components.
13. Make sure that you do not cross your electrical wiring with your signal wiring. This may cause distortion and interference.
14. The unit must be connected to the main outlet. Normally, the power supply must have an impedance of 32 ohms.
15. No other equipment should be connected to the same power circuit.
16. Connect the outdoor wires before connecting the indoor wires.

WARNING

BEFORE PERFORMING ANY ELECTRICAL OR WIRING WORK, TURN OFF THE MAIN POWER TO THE SYSTEM.

Note on Air switch

When the maximum current of the air conditioner is more than 16A, an air switch or leakage protection switch with protective device shall be used (purchased separately).

When the maximum current of the air conditioner is less than 16A, the power cord of air conditioner shall be equipped with plug (purchased separately).

Note on Residual current operated circuit-breakers

If connecting power to fixed wiring, an all-pole disconnection device which has at least 3mm clearances in all poles, and have a leakage current that may exceed 10mA, the residual current operated circuit-breakers with integral overcurrent protection having a rated residual operating current not exceeding 30mA, and disconnection must be incorporated in the fixed wiring in accordance with the wiring rules.

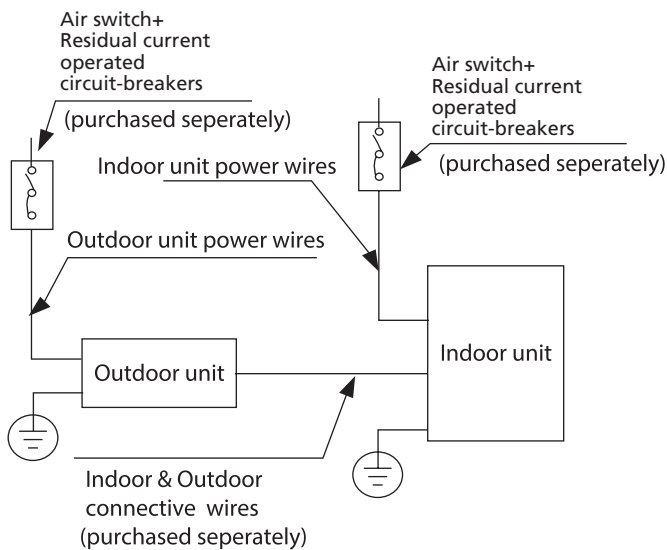

NOTE: The cographs are for explanation purpose only. Your machine may be slightly different. The actual shape shall prevail.

Outdoor Unit Wiring

⚠ WARNING

Before performing any electrical or wiring work, turn off the main power to the system.

1. Prepare the cable for connection
 - a. You must first choose the right cable size. Be sure to use H07RN-F cables.

Minimum Cross-Sectional Area of Power and Signal Cables (For reference)

Rated Current of Appliance (A)	Nominal Cross-Sectional Area (mm ²)
> 3 and ≤ 6	0.75
> 6 and ≤ 10	1
> 10 and ≤ 16	1.5
> 16 and ≤ 25	2.5
> 25 and ≤ 32	4
> 32 and ≤ 40	6

CHOOSE THE RIGHT CABLE SIZE

The size of the power supply cable, signal cable, fuse, and switch needed is determined by the maximum current of the unit. The maximum current is indicated on the nameplate located on the side panel of the unit. Refer to this nameplate to choose the right cable, fuse, or switch.

- b. Using wire strippers, strip the rubber jacket from both ends of the signal cable to reveal approximately 15cm (5.9") of wire.
- c. Strip the insulation from the ends.
- d. Using a wire crimper, crimp u-lugs on the ends.

NOTE: When connecting the wires, strictly follow the wiring diagram found inside the electrical box cover.

- Remove the electric cover of the outdoor unit. If there is no cover on the outdoor unit, take off the bolts from the maintenance board and remove the protection board.

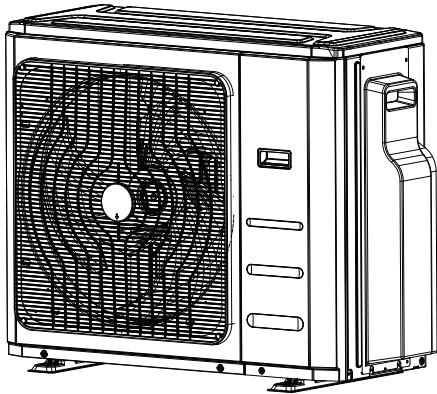

NOTE: Both the refrigerant pipeline of the hydraulic module and the power line connecting the outdoor unit must be connected to port A, otherwise it will fail to run and report a fault.

- Connect the u-lugs to the terminals. Match the wire colors/labels with the labels on the terminal block. Firmly screw the u-lug of each wire to its corresponding terminal.
- Clamp down the cable with the cable clamp.
- Insulate unused wires with electrical tape. Keep them away from any electrical or metal parts.
- Reinstall the cover of the electric control box.

Indoor Unit Wiring

- Prepare the cable for connection.
 - Using wire strippers, strip the rubber jacket from both ends of the signal cable to reveal about 15cm (5.9") of the wire.
 - Strip the insulation from the ends of the wires.
 - Using a wire crimper, crimp the u-lugs to the ends of the wires.

NOTE: The power cord passes through the cable hole and is secured with a cable tie.

- Remove the cover of the electric control box on your indoor unit.
- Connect the u-lugs to the terminals. Match the wire colors/labels with the labels on the terminal block. Firmly screw the u-lug of each wire to its corresponding terminal. Refer to the Serial Number and Wiring Diagram located on the cover of the electric control box.

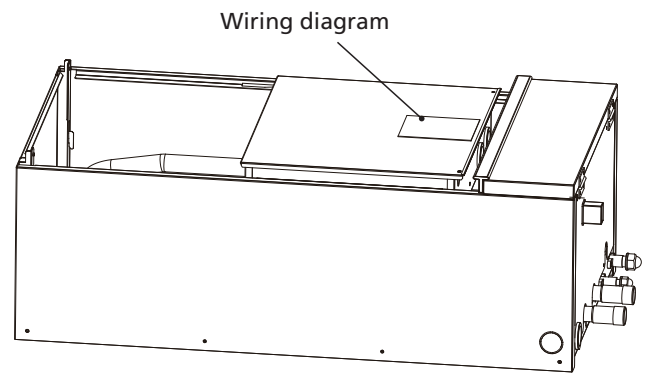

⚠ CAUTION

- While connecting the wires, please strictly follow the wiring diagram.
 - The refrigerant circuit can become very hot. Keep the interconnection cable away from the copper tube.
- Clamp down the cable with the cable clamp. The cable must not be loose or pull on the u-lugs.
 - Reattach the electric box cover.

1. Overview

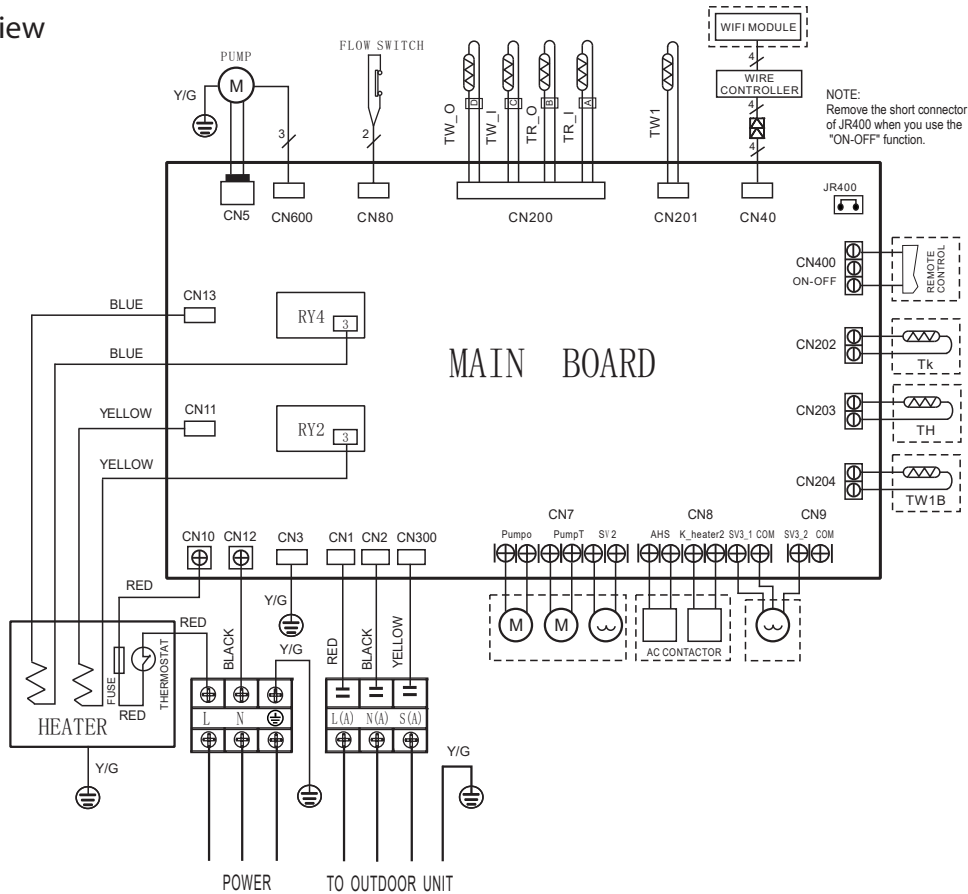

2. Interface Description

Weak load interface

CODE	PART NAME
TW_O	TEMPERATURE SENSOR FOR EXCHANGER OUTLET WATER
TW_I	TEMPERATURE SENSOR FOR EXCHANGER INLET WATER
TR_O	TEMPERATURE SENSOR FOR REFRIGERANT GAS
TR_I	TEMPERATURE SENSOR FOR REFRIGERANT LIQUID
TW1	TEMPERATURE SENSOR FOR OUTLET WATER OF HYDRAULIC MODULE
Tk	TEMPERATURE SENSOR FOR WATER OF WATER TANK
TH	TEMPERATURE SENSOR FOR RETURN WATER
TW1B	TEMPERATURE SENSOR FOR TOTAL OUTLET WATER
Sv2	2-WAY VALVE
Sv3_1,SV3_2	3-WAY VALVE
AHS	CONTROL SIGNAL OF ASSISTANT HEAT SOURCE
Pumpo	PUMP
PumpT	PUMP FOR RETURN WATER/PUMP FOR MIXING WATER
K_heater2	CONTROL SIGNAL OF WATER TANK HEATER
RY2,RY4	RELAY

Engineering load control interface

CODE	PART NAME
SV2	2-WAY VALVE
Sv3_1,SV3_2	3-WAY VALVE
AHS	CONTROL SIGNAL OF ASSISTANT HEAT SOURCE
Pumpo	PUMP
PumpT	PUMP FOR RETURN WATER/PUMP FOR MIXING WATER
K_heater2	CONTROL SIGNAL OF WATER TANK HEATER
RY2,RY4	RELAY

- 1) The output of the mainboard engineering load control interface is a strong electric signal, so it must be powered off.
- 2) The engineering load control interface is only used as a signal output. The total output current of the mainboard cannot exceed 2.5A, otherwise it will cause overload and damage the machine.
- 3) Please connect the engineering load in strict accordance with the wiring diagram. The excessive load power needs to be controlled by the AC contactor. AHS and K_heater2 must pass the AC CONTACTOR control.
- 4) The connection and installation of external engineering loads must be well protected, such as earthed effectively, air switch and residual current operated circuit-breakers. The installation of engineering load shall be installed in strict accordance with the instruction manual of the load and control components and local regulations.

3. Remote switch function

"CN400" terminal is used for remote ON-OFF switch; when using this function, this interface is connected to external control switch, remove the short connector of JR400 when you use the "ON-OFF" function.

The control logic is as follows:

Remote switch short circuit: the machine is controlled as normal.

Remote switch off: the machine enters remote control.

4. DIP SWITCH FUNCTION

DIP SWITCH	FUNCTION	OFF	ON	DEFAULT SETTING	
SW1	SW1-1	—	—	OFF	
	SW1-2	TW1B	WITHOUT TW1B	WITH TW1B	OFF
	SW1-3	TH	WITHOUT TH	WITH TH	OFF
	SW1-4	TK	WITHOUT TK	WITH TK	OFF



Note: Slide the switch to numbers position indicates "OFF".

5. Battery installation

1. The battery is placed in the accessory bag and needs to be installed in the wired controller on site.
2. Please remove the wired controller, place the battery in the unit and ensure the positive side of the battery is in accordance with the polarity markings.
3. Set the correct time before operating. Battery in the wired controller can maintain the correct time during a power failure. When the power is restored and the displayed time is not correct, replace the battery.

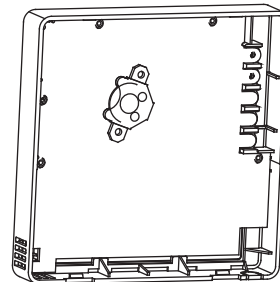
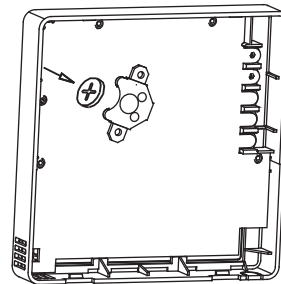

NOTE :

1. Special power supply shall be used for the hydraulic module, and the power supply voltage shall conform to the rated voltage.
2. The power line ground wire of hydraulic module must be reliably connected with the effective ground wire of external power supply.
3. Wiring construction must be carried out by professional technicians according to the circuit icon.
4. The connected fixed line must be equipped with a full pole disconnecting device (e.g. air switch or Leakage protection switch, etc.).
5. In accordance with the requirements of relevant national technical standards for electrical equipment, leakage protection devices shall be set up.
6. The layout of power line and signal line shall be neat, reasonable and not interfere with each other, and shall not be connected with connecting pipe and valve body Touch. Generally, it is not allowed to connect two wires unless the joints are firmly welded and wrapped with insulating tape.
7. After all wiring construction is completed, the power supply can only be connected after careful inspection.

Power Specifications

Indoor Power Supply Specifications

MODEL(Btu/h)		42K
POWER	PHASE	1 Phase
	VOLT	220-240V
CIRCUIT BREAKER/ FUSE(A)		32

Air Evacuation

Preparations and Precautions

Air and foreign matter in the refrigerant circuit can cause abnormal rises in pressure, which can damage the air conditioner, reduce its efficiency, and cause injury. Use a vacuum pump and manifold gauge to evacuate the refrigerant circuit, removing any non-condensable gas and moisture from the system.

Evacuation should be performed upon initial installation and when unit is relocated.

BEFORE PERFORMING EVACUATION

- ☑ Check to make sure the connective pipes between the indoor and outdoor units are connected properly.
- ☑ Check to make sure all wiring is connected properly.

Evacuation Instructions

1. Connect the charge hose of the manifold gauge to service port on the outdoor unit's low pressure valve.
2. Connect another charge hose from the manifold gauge to the vacuum pump.
3. Open the Low Pressure side of the manifold gauge. Keep the High Pressure side closed.
4. Turn on the vacuum pump to evacuate the system.
5. Run the vacuum for at least 15 minutes, or until the Compound Meter reads -76cmHG (-10⁵Pa).

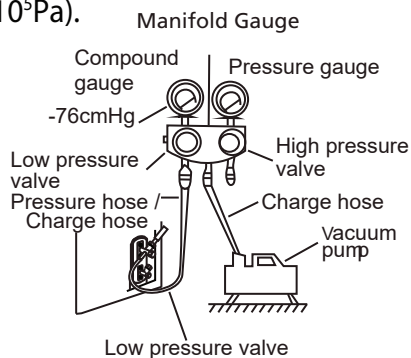

6. Close the Low Pressure side of the manifold gauge, and turn off the vacuum pump.
7. Wait for 5 minutes, then check that there has been no change in system pressure.
8. If there is a change in system pressure, refer to Gas Leak Check section for information on how to check for leaks. If there is no change in system pressure, unscrew the cap from the packed valve (high pressure valve).
9. Insert hexagonal wrench into the packed valve (high pressure valve) and open the valve by turning the wrench in a 1/4 counterclockwise turn. Listen for gas to exit the system, then close the valve after 5 seconds.
10. Watch the Pressure Gauge for one minute to make sure that there is no change in pressure. The Pressure Gauge should read slightly higher than atmospheric pressure.
11. Remove the charge hose from the service port.

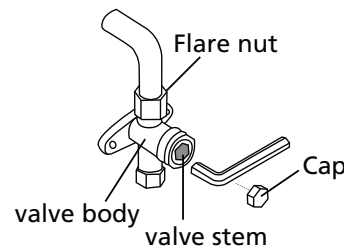

12. Using hexagonal wrench, fully open both the high pressure and low pressure valves.
13. Tighten valve caps on all three valves (service port, high pressure, low pressure) by hand. You may tighten it further using a torque wrench if needed.

! OPEN VALVE STEMS GENTLY

When opening valve stems, turn the hexagonal wrench until it hits against the stopper. Do not try to force the valve to open further.

Note on Adding Refrigerant

Some systems require additional charging depending on pipe lengths. The standard pipe length varies according to local regulations. For example, in North America, the standard pipe length is 7.5m (25'). In other areas, the standard pipe length is 5m (16'). The refrigerant should be charged from the service port on the outdoor unit's low pressure valve. The additional refrigerant to be charged can be calculated using the following formula:

Liquid Side Diameter

	φ6.35(1/4")	φ9.52(3/8")	φ12.7(1/2")
R22 (orifice tube in the indoor unit):	(Total pipe length - standard pipe length) x 30g (0.32oz)/m(ft)	(Total pipe length - standard pipe length) x 65g(0.69oz)/m(ft)	(Total pipe length - standard pipe length) x 115g(1.23oz)/m(ft)
R22 (orifice tube in the outdoor unit):	(Total pipe length - standard pipe length) x 15g(0.16oz)/m(ft)	(Total pipe length - standard pipe length) x 30(0.32oz)/m(ft)	(Total pipe length - standard pipe length) x 60g(0.64oz)/m(ft)
R410A: (orifice tube in the indoor unit):	(Total pipe length - standard pipe length) x 30g(0.32oz)/m(ft)	(Total pipe length - standard pipe length) x 65g(0.69oz)/m(ft)	(Total pipe length - standard pipe length) x 115g(1.23oz)/m(ft)
R410A: (orifice tube in the outdoor unit):	(Total pipe length - standard pipe length) x 15g(0.16oz)/m(ft)	(Total pipe length - standard pipe length) x 30g(0.32oz)/m(ft)	(Total pipe length - standard pipe length) x 65g(0.69oz)/m(ft)
R32 :	(Total pipe length - standard pipe length) x 12g(0.13oz)/m(ft)	(Total pipe length - standard pipe length) x 24g(0.26oz)/m(ft)	(Total pipe length - standard pipe length) x 40g(0.42oz)/m(ft)

 **CAUTION** DO NOT mix refrigerant types.

Test Run

Before Test Run

A test run must be performed after the entire system has been completely installed. Confirm the following points before performing the test:

- a) Indoor and outdoor units are properly installed.
- b) Piping and wiring are properly connected.
- c) No obstacles near the inlet and outlet of the unit that might cause poor performance or product malfunction.
- d) Refrigeration system does not leak.
- e) Drainage system is unimpeded and draining to a safe location.
- f) Heating insulation is properly installed.
- g) Grounding wires are properly connected.
- h) Length of the piping and additional refrigerant stow capacity have been recorded.
- i) Power voltage is the correct voltage for the air conditioner.

CAUTION

Failure to perform the test run may result in unit damage, property damage, or personal injury.

Test Run Instructions

1. Open both the liquid and gas stop valves.
2. Turn on the main power switch and allow the unit to warm up.
3. For the Indoor Unit
 - a. Ensure the wired controller and its buttons work properly.
 - b. Double check to see if the water temperature is being registered correctly.
 - c. Check to see that the drainage system is unimpeded and draining smoothly. If the water quality is poor, an electronic water treatment device or scale inhibitors should be used to ensure the water quality.
 - d. Ensure there is no vibration or abnormal noise during operation.

4. For the Outdoor Unit

- a. Check to see if the refrigeration system is leaking.
- b. Make sure there is no vibration or abnormal noise during operation.
- c. Ensure the wind, noise, and water generated by the unit do not disturb your neighbors or pose a safety hazard.

NOTE: If the unit malfunctions or does not operate according to your expectations, please refer to the Troubleshooting section of the Owner's Manual before calling customer service.

160106000000826
WIRING DIAGRAM

NOTE: Remove the short connector of Jr400 when you use the "on-off" function.

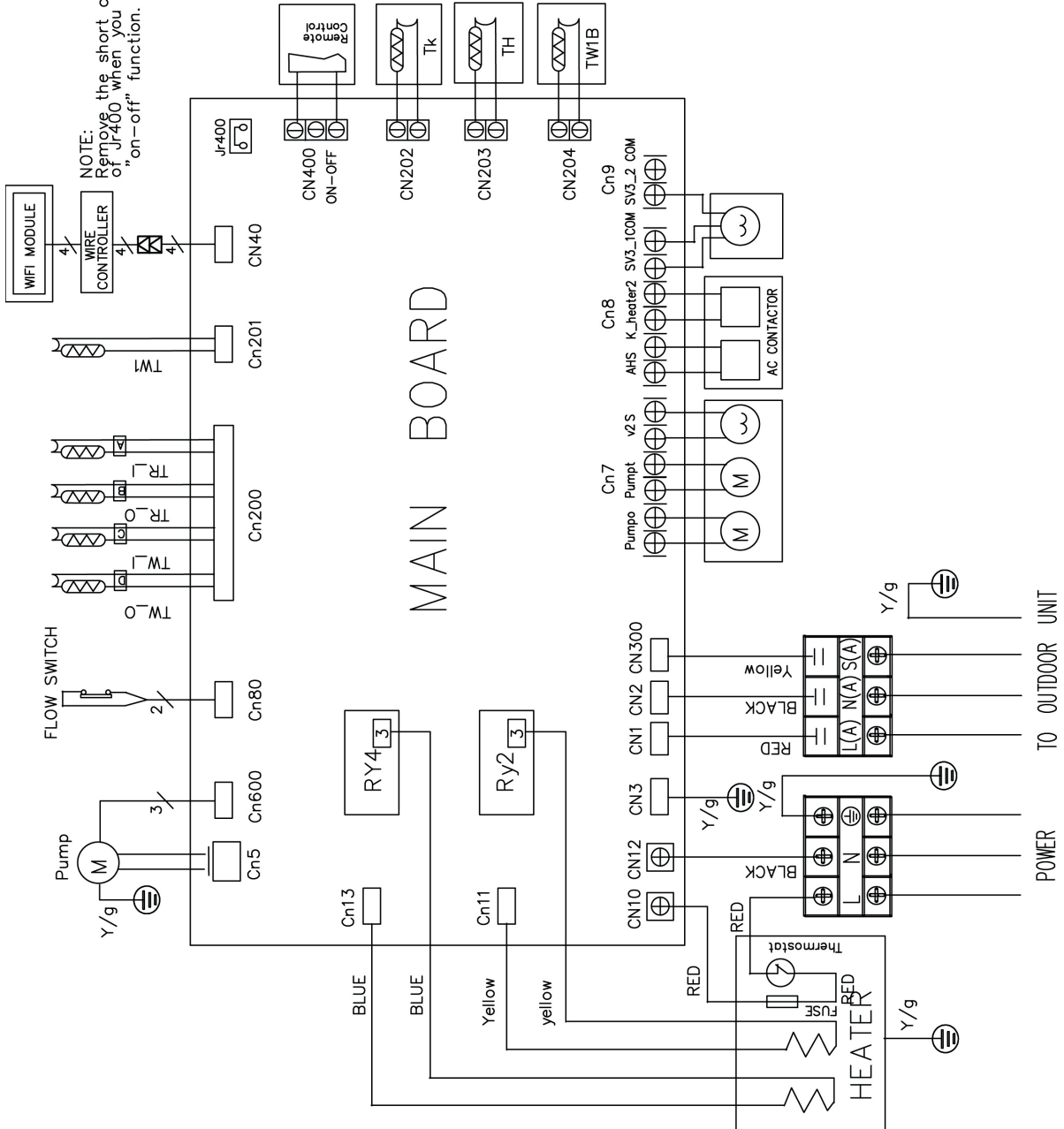

CODE	PART NAME
TW_0	TEMPERATURE SENSOR FOR EXCHANGER OUTLET WATER
TW_J	TEMPERATURE SENSOR FOR EXCHANGER INLET WATER
TR_0	TEMPERATURE SENSOR FOR REFRIGERANT GAS
TR_J	TEMPERATURE SENSOR FOR REFRIGERANT LIQUID
TW1	TEMPERATURE SENSOR FOR OUTLET WATER OF HYDRAULIC MODULE
Tk	TEMPERATURE SENSOR FOR WATER OF WATER TANK
TH	TEMPERATURE SENSOR FOR RETURN WATER
TWIB	TEMPERATURE SENSOR FOR TOTAL OUTLET WATER
SV2	2-WAY VALVE
SV3_1,SV3_2	3-WAY VALVE
AHS	CONTROL SIGNAL OF ASSISTANT HEAT SOURCE
Pumpo	PUMP
PumpI	PUMP FOR RETURN WATER/PUMP FOR MIXING WATER
K_heater2	CONTROL SIGNAL OF WATER TANK HEATER
RY2,RY4	RELAY

DIP SWITCH	FUNCTION	OFF	ON	DEFAULT SETTING
Sw1-1	—	—	—	Sw1
Sw1-2	TWIB	WITHOUT tw1b	WITH tw1b	OFF
Sw1-3	TH	WITHOUT th	WITH th	OFF
Sw1-4	TK	WITHOUT tk	WITH tk	OFF



Note: Slide the switch to the position indicated by "OFF".

Note: This symbol indicates the element is optional, the actual shape shall be prevail.

SERIES	SIZE
IHM1-Y	80M

USER MANUAL OF SMART KIT

IMPORTANT NOTE:

Read the manual carefully before connecting your Smart kit (Wireless module).

Make sure to save this manual for future reference. Illustrations in this manual are for explanatory purposes. The actual shape shall prevail.

CONTENTS

1. SPECIFICATION.....	3
2. INSTALL THE SMART KIT	3
3. DOWNLOAD AND INSTALL APP.....	5
4. PREPARATION	5
5. USER REGISTRATION	6
6. NETWORK CONFIGURATION.....	7
7. HOW TO USE APP.....	12
8. FUNCTIONS	13
9. APP DECLARATION	17

DECLARATION OF CONFORMITY

Hereby, we declare that this Smart kit is in compliance with the essential requirements and other relevant provisions of Directive 2014/53/EU. A copy of the full DoC is attached.
(European Union products only)

1. SPECIFICATION

Model: EU-SK105, US-SK105

Standard: IEEE 802.11b/g/n

Antenna Type: Printed PCB Antenna

Frequency Band: 2400-2483.5MHz

Operation Temperature: 0 °C~45°C/32°F~113°F

Operation Humidity: 10%~85%

Power Input: DC 5V/300mA

Maximum TX Power: <20dBm

NOTE:

Company will not be liable for any issues and problems caused by Internet, Wireless Router and Smart Devices. Please contact the original provider to get further help.

2. INSTALL THE SMART KIT

1. Remove the two screws fixed on the lower cover of the case and the wire controller mounting plate, and knock down the reserved hole .
2. Open the switch door, take out the wire controller and the installation sheet metal, and open the upper cover of the wire controller with a tool.

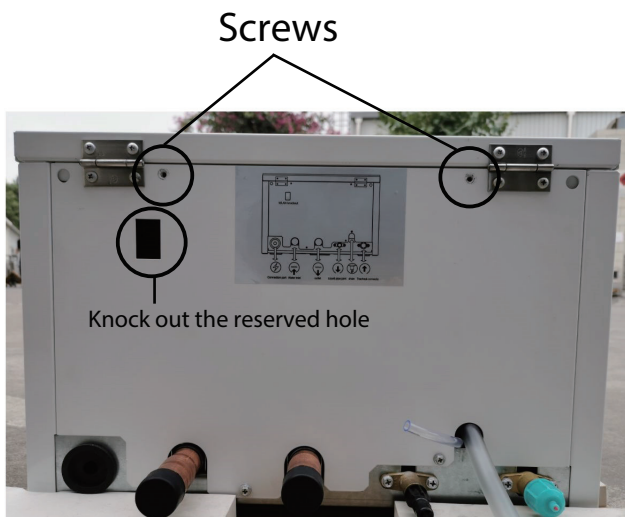

3. Take out the Wireless module connection cable from the accessory bag, insert it into the PCB of the wire controller, and the wire body comes out from the hole in the lower cover of the wire controller.

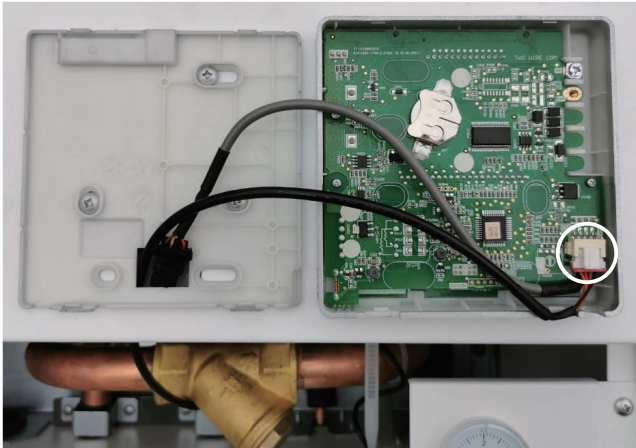

4. Reattach the upper cover assembly and the lower cover of the wire controller. The Wireless module connection cable is fixed by the cable tie on the electric control box.



5. Remove the Wireless installation rubber and Wireless module from the accessories, and install the rubber parts on the lower cover of the housing.

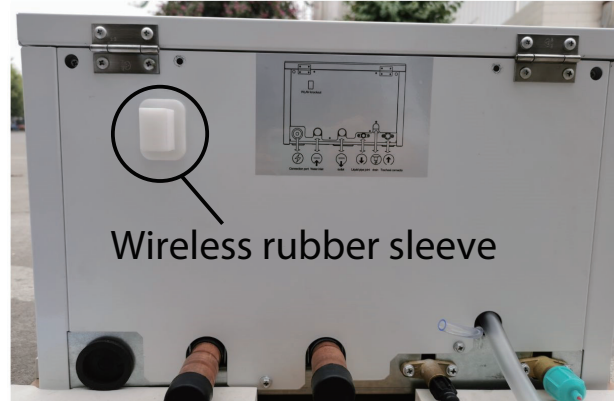

6. Pair the USB cable with the Wireless module, and insert the Wireless module into the rubber on the lower cover of the case.

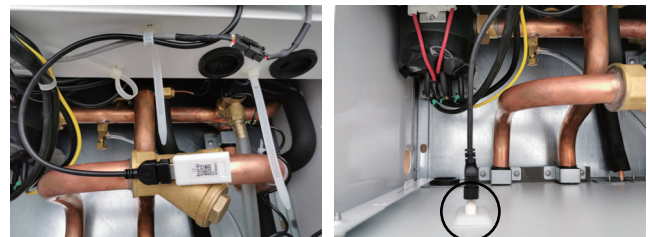

Wireless module

7. Put the wire controller mounting plate into the machine again, close the switch door, then fix it with screws, and stick the QR code in the attachment to the Wireless rubber attachment on the lower cover of the case.

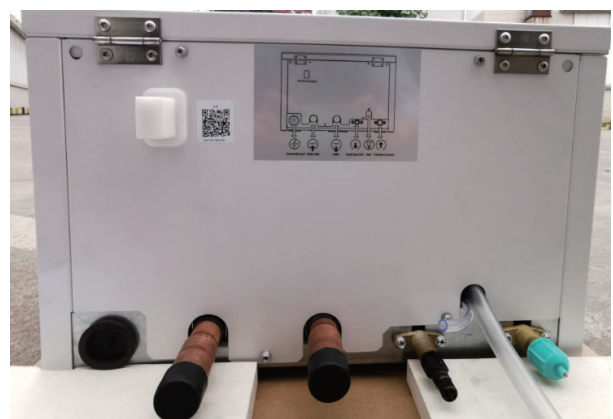

3. DOWNLOAD AND INSTALL APP

CAUTION: The following QR code is only available for downloading APP. It is totally different with the QR code packed with unit.



Android



iOS

- Android Phone users: scan Android QR code or go to google play, search "NetHome Plus" app and download it.
- iOS users: scan iOS QR code or go to APP Store, search "NetHome Plus" app and download it.

4. PREPARATION

- Applicable system: iOS, Android.
(Suggest: iOS 8.0 or later, Android 4.0 or later)
 - Please keep you APP up to date with the latest version.
 - Due to special situation may be occurred, we explicitly claims below: Not all of the Android and iOS system are compatible with APP. We will not be responsible for any issue as a result of the incompatibility.
- **Wireless safety strategy**
Smart kit only support WPA-PSK/WPA2-PSK encryption and none encryption. WPA-PSK/WPA2-PSK encryption is recommended.
- **Cautions**
 - Due to different network situation, control process may return timeout sometimes. If this situation occurs, the display between board and App may not be the same , please do not feel confused.
 - Smart Phone camera needs to be 5 million pixels or above to make sure scan QR code well.
 - Due to different network situation, sometimes,request time-out could happen , thus, it is necessary to do network configuration again.
 - The APP system is subject to update without prior notice for product function improvement. The actual network configuration process may be slightly different from the manual, the actual process shall prevail.
 - Please Check The Service Website For More information.

5. USER REGISTRATION

- Please ensure your mobile device is connected to Wireless router. Also, the Wireless router has already connected to Internet before doing user registration and network configuration.
- It is better to log in your email box and active your registration account by clicking link in case you forget the password. You can log in with the third party accounts.

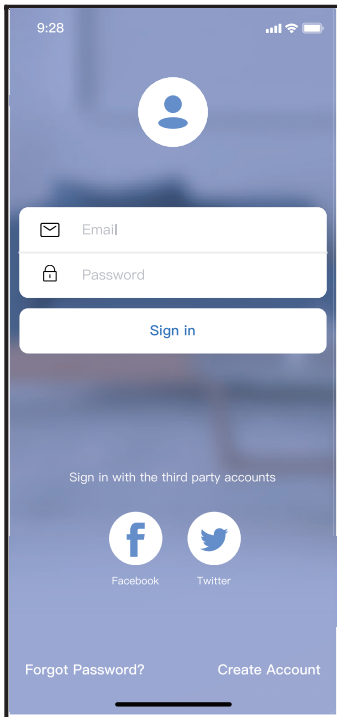

Android

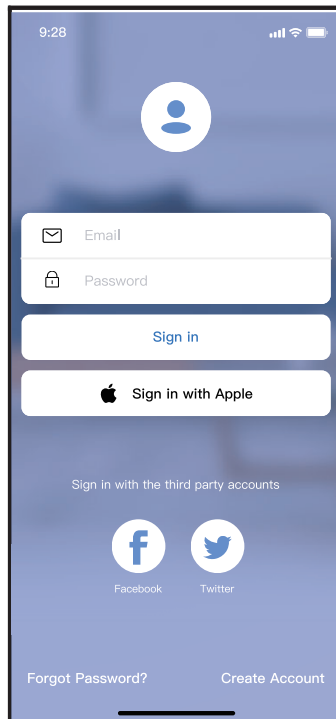

iOS

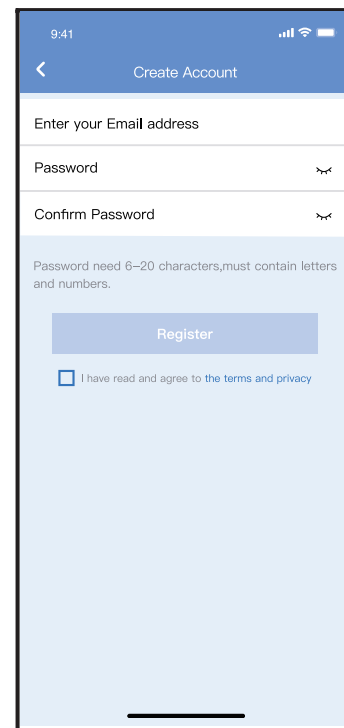

① Click "Create Account"

② Enter your email address and password, and then click "Register"

6. NETWORK CONFIGURATION

Cautions

- It is necessary to forget any other around network and make sure the Android or iOS device just connect to the Wireless network you want to configure.
- Make sure the Android or iOS device Wireless function works well and can be connected back to your original Wireless network automatically.

Kindly reminder :

User must finish all the steps in 8 minutes after powering on air conditioner, otherwise you need to power on it again.

■ Using Android or iOS device to do network configuration

- Make sure your mobile device has already been connect to the Wireless network which you want to use. Also, you need to forget other irrelevant Wireless network in case it influences your configuration process.
- Disconnect the power supply of AC.
- Connect the power supply of AC, activate the AP mode (The pictures in the manual are for explanation purpose only. Your machine may be slightly different. Read the WIRELESS MODE IN USER'S MANUAL or INSTRUCTION MANUAL for detailed operations.).
- When AP appears in the display, It means that the AC WIRELESS has already entered into AP Mode. User can do the next step configuration.

Note:

There are two ways to finish the network configuration:

- Network configuration by Bluetooth scan
- Network configuration by select appliance type

Network configuration by Bluetooth scan

Note: Make sure the bluetooth of your mobile device is working.

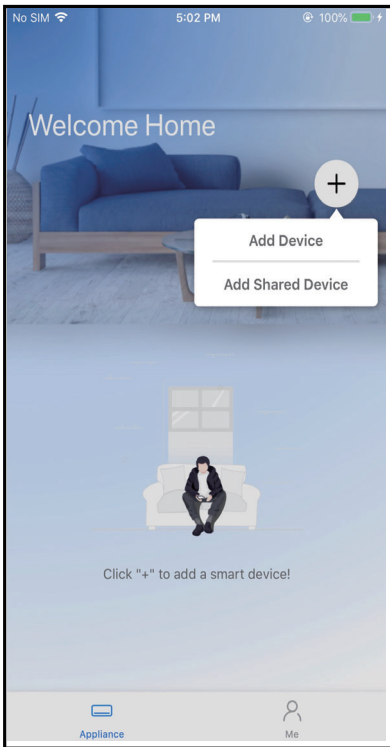

① Press "+ Add Device"

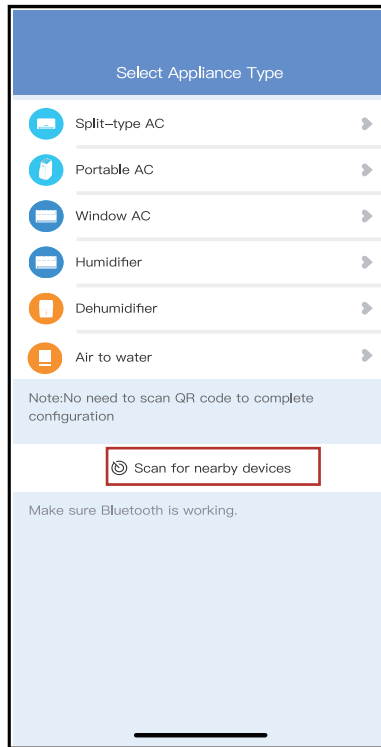

② Press "Scan for nearby devices"

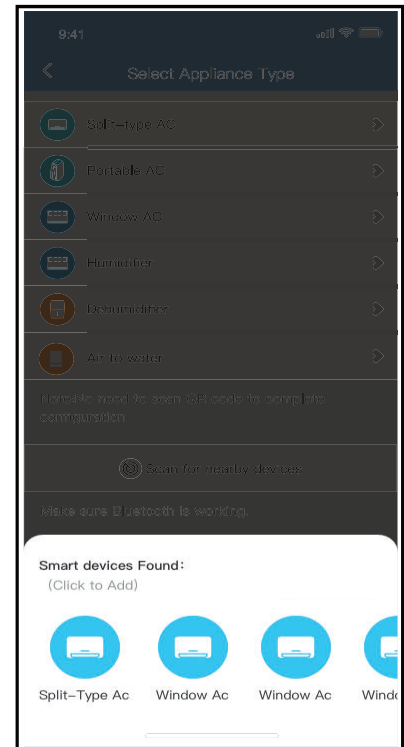

③ Wait smart devices to find, then click to add it

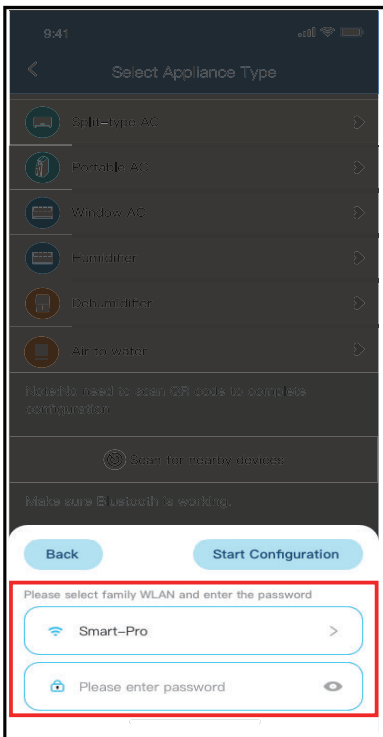

④ Select home Wi-Fi, enter the password

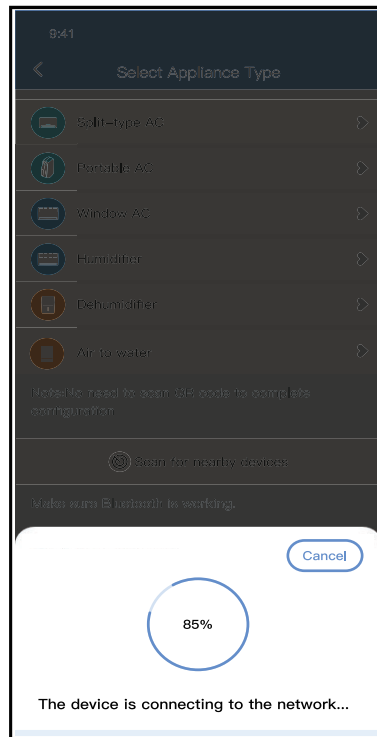

⑤ Wait connecting to the network

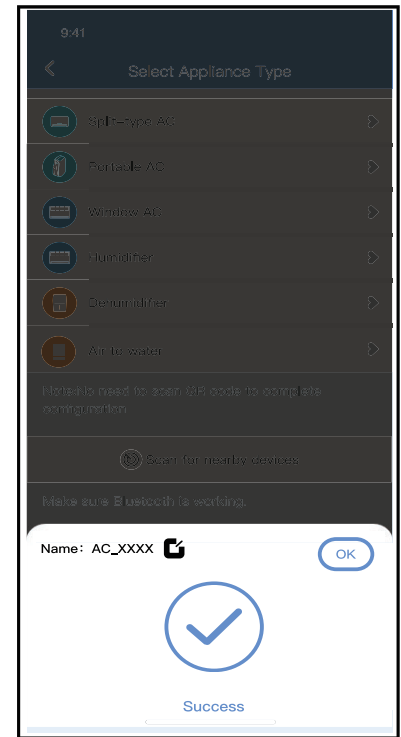

⑥ Configuration Success, you can modify the default name.

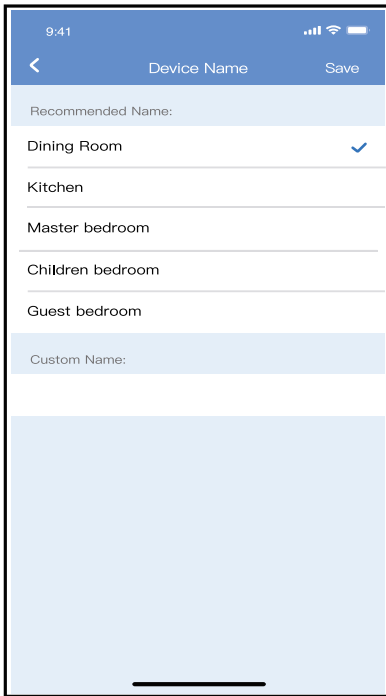

⑦ You can choose an existing name or customize a new name.

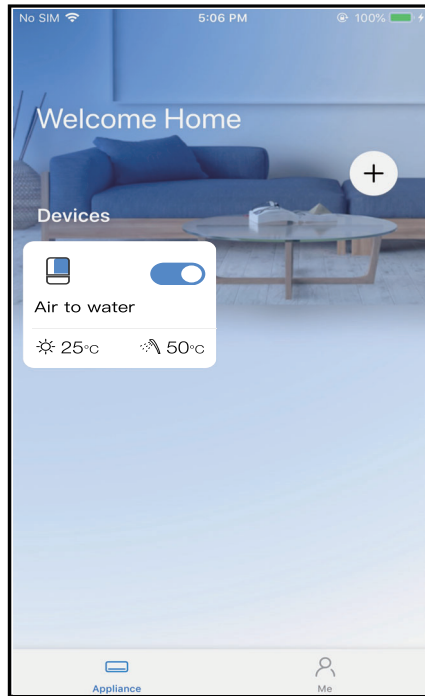

⑧ Bluetooth network configuration is successful, now you can see the device in the list.

Network configuration by select appliance type :

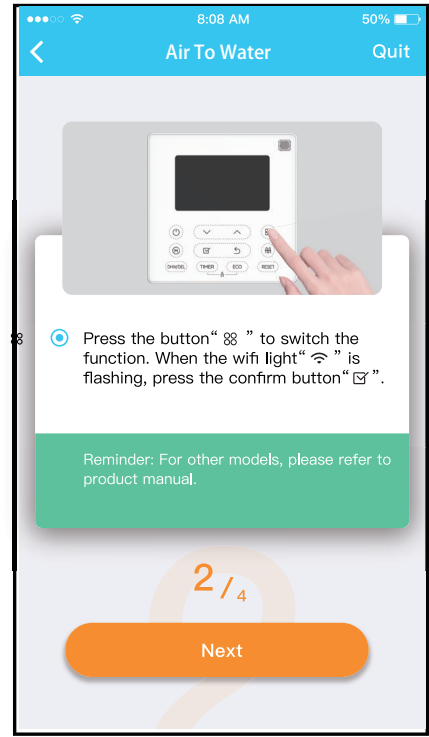
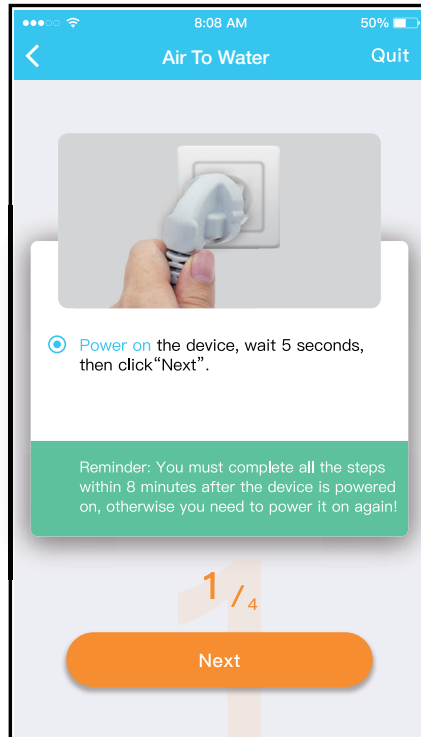
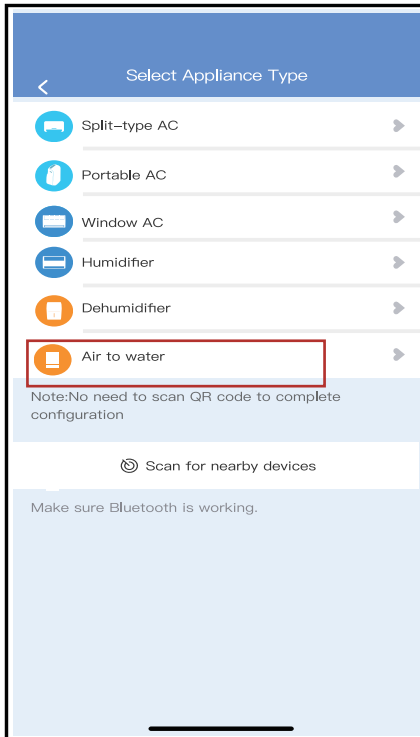

① If the bluetooth network configuration is failure, please select the appliance type.

② Follow the above steps to enter "AP" mode.

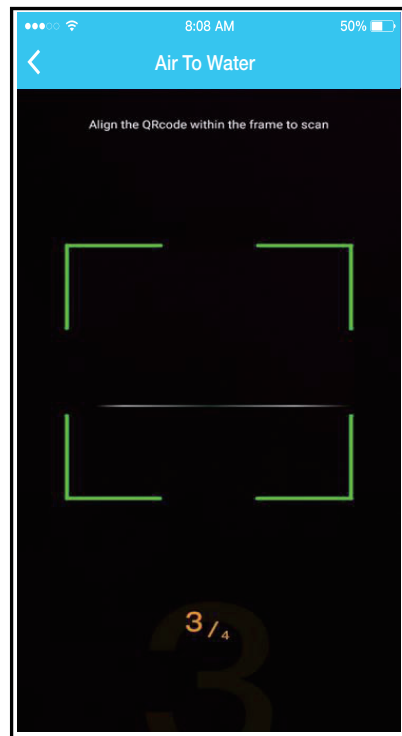
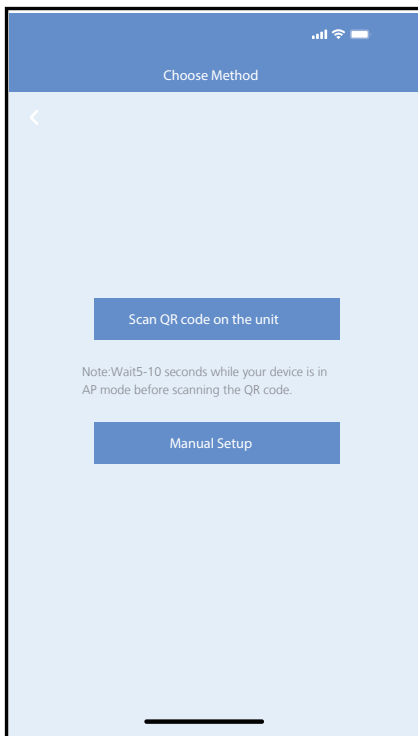

③ Choose the network configuration method.

④ Choose the "Scan the QR code" method.

⑤ When choose the "Manual Setup" method (Android). Connect to the wireless network (iOS)

NOTE: Steps ③ and ④ are applicable to Android system only. iOS system does not need these two steps.

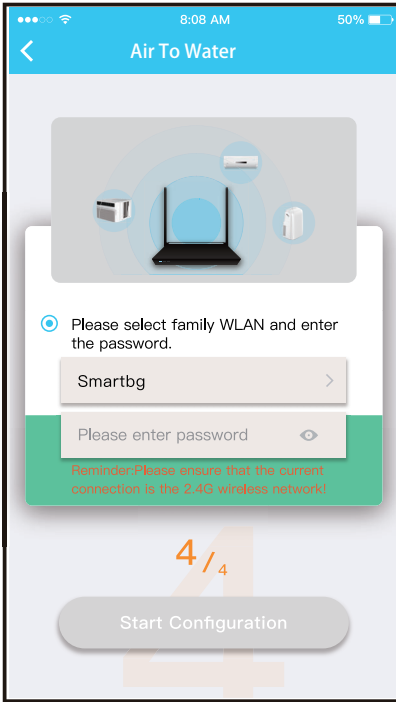

⑥ Please enter password

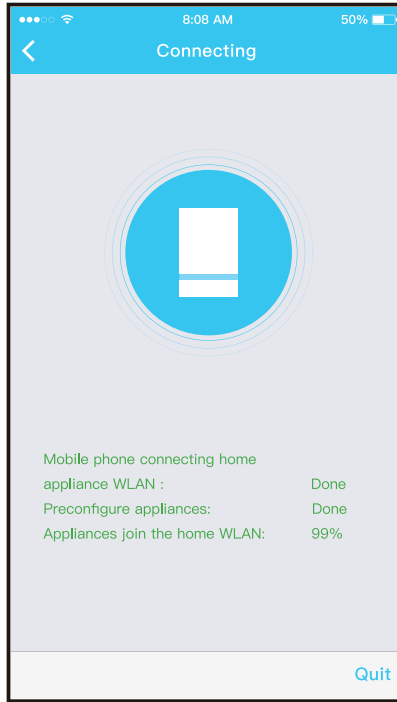

⑦ Network configuration is successful.

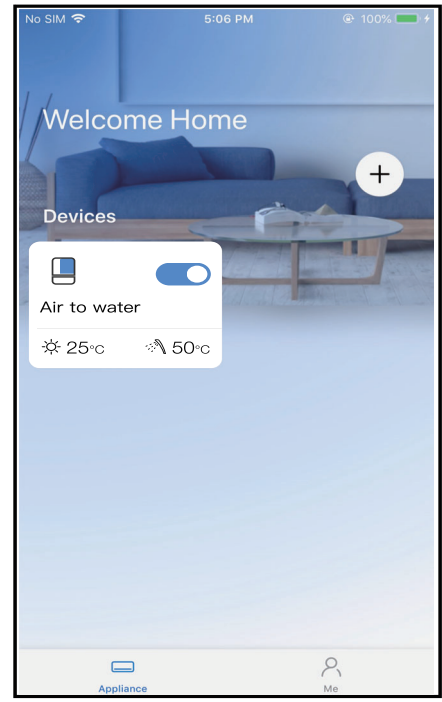

⑧ Configuration Success, you can see the device on the list.

NOTE:

- When finishing network configuration, APP will display success cue words on the screen.
- Due to different internet environment, it is possible that the device status still display “offline” . If this situation occurs, it is necessary to pull and refresh the device list on the APP and make sure the device status become “online” . Alternatively, user can turn off the AC power and turn on it again, the device status will become “online” after few minutes.

7. HOW TO USE APP

Please ensure both your mobile device and air conditioner are connected to the Internet before using app to control the air conditioner via internet, please follow the next steps:

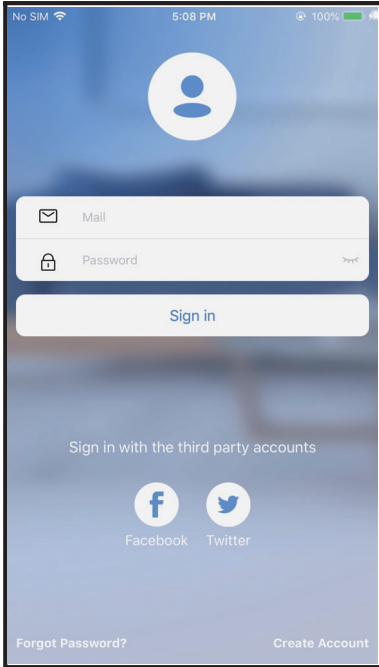

① Click "Sign up"

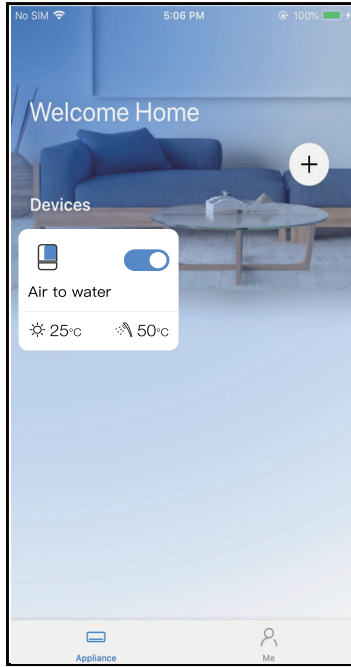

② Choose the air conditioner.

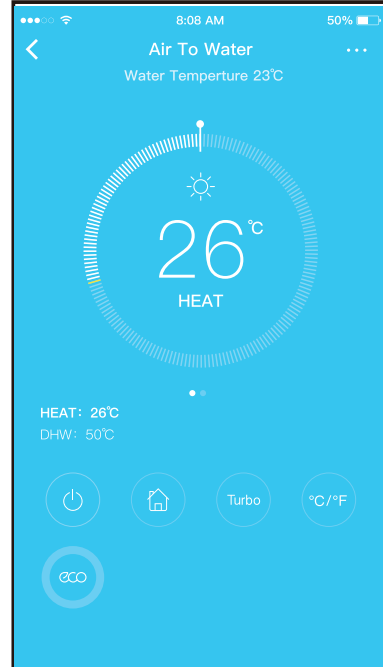

③ Thus, user can control air conditioners on/off status, operation mode, temperature, fan speed and so on.

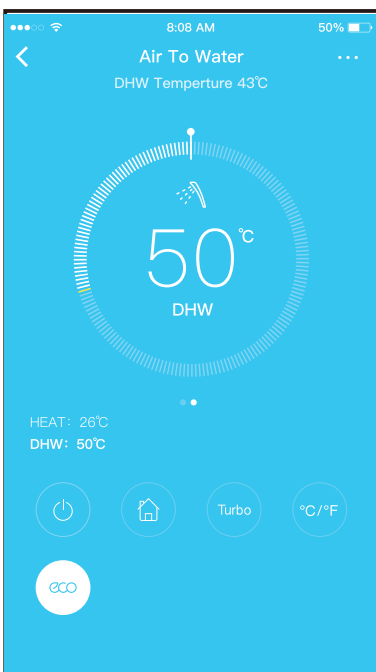

NOTE:

Heat The temperature adjustment range is 25°C -60°C.
The initial default temperature is 35°C.

The DWH temperature adjustment range is 35°C -55 °C.
The initial default temperature is 50 °C.

The interactive method of temperature adjustment is ring adjustment.

Not all the function of the APP is available on air conditioner. For example: ECO, Turbo, please check the user manual to find more information.

8. FUNCTIONS

■ ON/OFF

In the shutdown state, there is a separate shutdown status page. Click the  button to enter the device control page.

In the power-on state, click the , the device will shut down, and the page will jump to the shutdown state page.

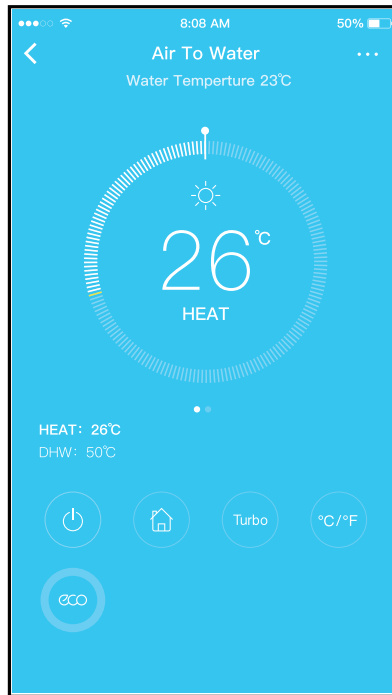

■ Mode

Click the Mode button to select Heat, DHW, Heat+DHW modes.

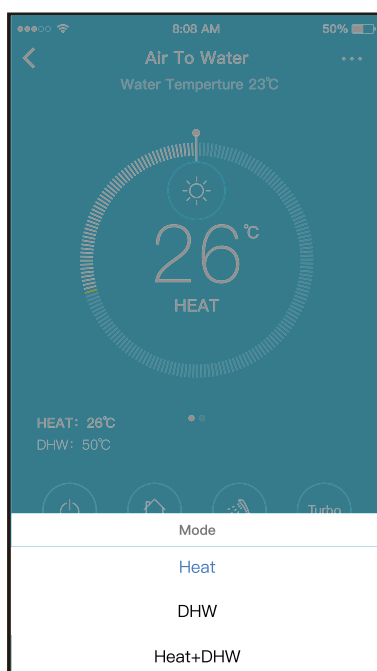
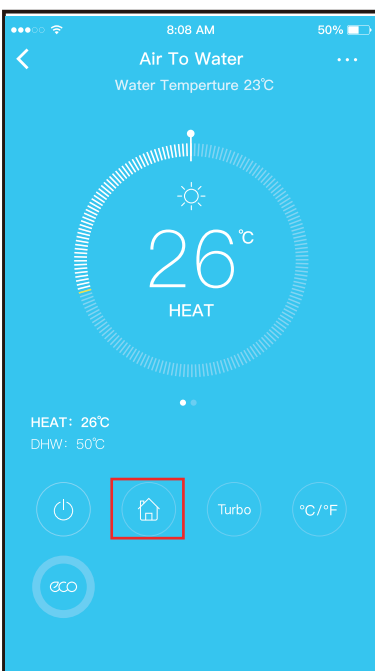

■ Turbo

Click the Turbo button to select Heat, DHW, Heat+DHW modes.

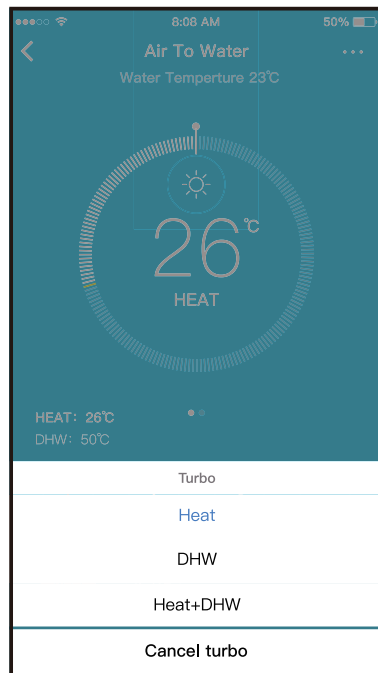
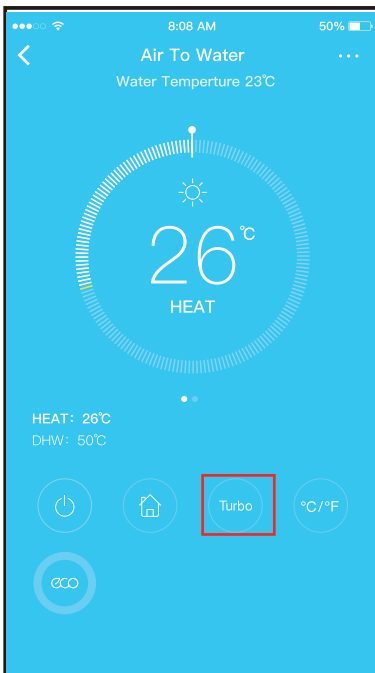

■ Eco

In Heat or Heat+DHW mode, press the eco button to turn on or turn off the eco function. In DHW mode, there is no eco function.

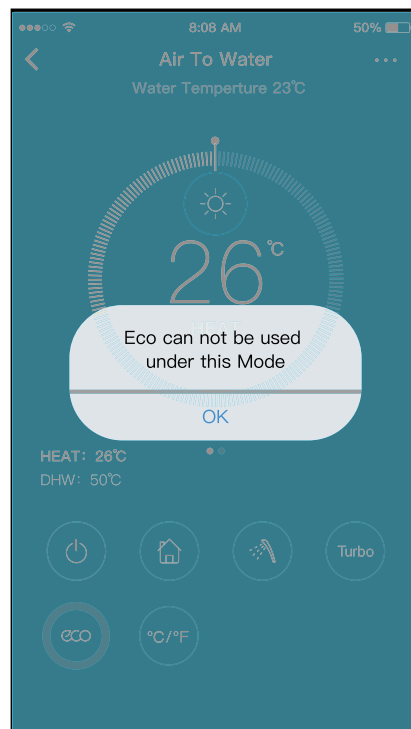
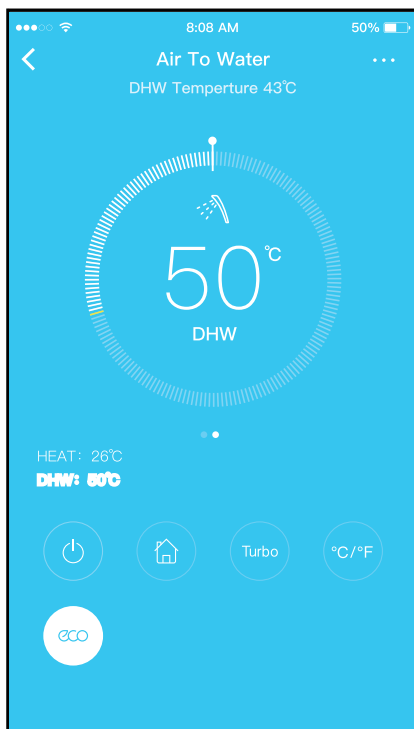

■ °C/°F

Press this button will alternate the temperature display between the °C & °F.

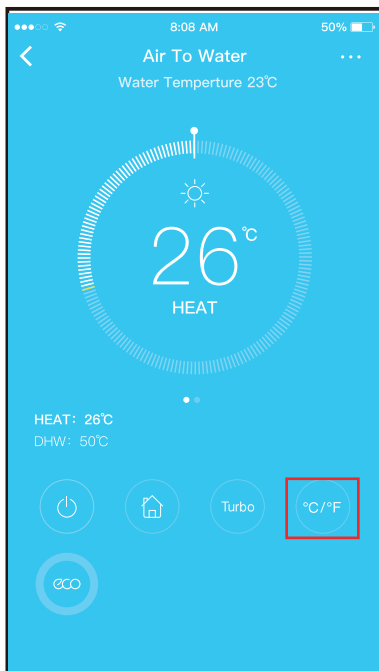

■ Share Device

The air conditioner can be controlled by multi-users at the same time by Share Device function.

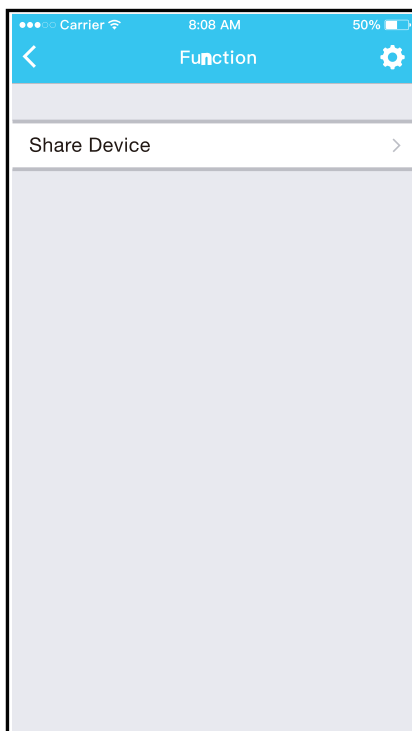

① Click "Share device "



② Let the others to scan the displayed QR code.

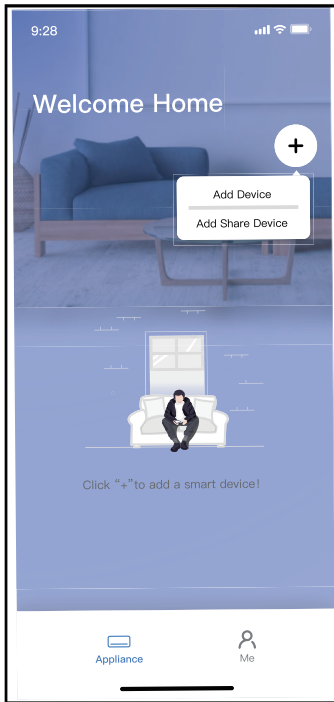

- ③ The other users must log in “Nethome Plus” app first, then click “Add Share Device” on their own mobile, then ask them to scan the QR code.

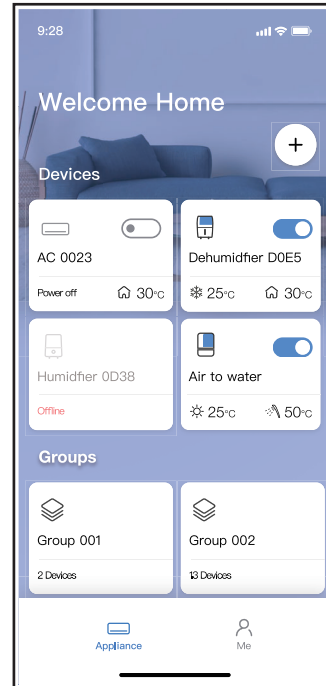

- ④ Now the others can add the shared device.

9. APP DECLARATION

For models of US-SK105,EU-SK105

FCC ID: 2ADQOMDNA21

IC: 12575A-MDNA21

This device complies with Part 15 of the FCC Rules and it contains licence-exempt transmitter(s)/receiver(s) that comply with Innovation, Science and Economic Development Canada's licence-exempt RSS(s).

Operation is subject to the following two conditions:

- (1) This device may not cause interference;and
- (2) This device must acceptany interference,including interference that may cause undesired operation of the device.

Only operate the device in accordance with the instructions supplied. Changes or modifications to this unit not expressly approved by the party responsible for compliance could void the user's authority to operate the equipment.This device complies with FCC radiation exposure limits set forth for an uncontrolled environment. In order to avoid the possibility of exceeding the FCC radio frequency exposure limits, human proximity to the antenna shall not be less than 20cm (8 inches) during normal operation.

NOTE: This equipment has been tested and found to comply with the limits for a Class B digital device, pursuant to part 15 of the FCC Rules. These limits are designed to provide reasonable protection against harmful interference in a residential installation. This equipment generates, uses and can radiate radio frequency energy and, if not installed and used in accordance with the instructions, may cause harmful interference to radio communications. However, there is no guarantee that interference will not occur in a particular installation.

If this equipment does cause harmful interference to radio or television reception, which can be determined by turning the equipment off and on, the user is encouraged to try to correct the interference by one or more of the following measures:

- Reorient or relocate the receiving antenna.
- Increase the separation between the equipment and receiver.
- Connect the equipment into an outlet on a circuit different from that to which the receiver is connected.
- Consult the dealer or an experienced radio/TV technician for help.

Hereby, we declare that this AC is in compliance with the essential requirements and other relevant provisions of RE Directive 2014/53/EU.

A copy of the full DoC is attached.

Company will not be liable for any issues and problems caused by Internet, Wireless Router and Smart Devices. Please contact the original provider to get further help.

NOTE:

All the illustrations in the manual are for explanation purpose only. Your unit may be slightly different. The actual shape shall prevail.



DECLARATION OF CONFORMITY EU

DICHIARAZIONE DI CONFORMITÀ UE
 KONFORMITÄTSEKKLÄRUNG EU
 DECLARATION DE CONFORMITE EU
 DECLARACIÓN DE CONFORMIDAD EU

WE DECLARE UNDER OUR SOLE RESPONSIBILITY THAT THE MACHINE

DICHIARIAMO SOTTO LA NOSTRA SOLA RESPONSABILITÀ CHE LA MACCHINA
 WIR ERKLÄREN EIGENVERANTWORTLICH, DASS DIE MASCHINE
 NOUS DÉCLARONS SOUS NOTRE SEULE RESPONSABILITÉ QUE LA MACHINE
 EL FABRICANTE DECLARA BAJO SU EXCLUSIVA RESPONSABILIDAD QUE LA MÁQUINA

CATEGORY	WATER CHILLERS - Heat pump
CATEGORIA	REFRIGERATORI D'ACQUA - Pompa di calore
KATEGORIE	KALTWASSERSÄTZE - Wärmepumpe
CATEGORIE	RÉFRIGÉRATEURS D'EAU - Pompe à chaleur
CATEGORIA	ENFRIADORAS DE AGUA - Bomba de calor

TYPE / TIPO / TYP / TYPE / TIPO

IHM1-Y 80M

- COMPLIES WITH THE FOLLOWING EEC DIRECTIVES, INCLUDING THE MOST RECENT AMENDMENTS, AND THE RELEVANT NATIONAL HARMONISATION LEGISLATION CURRENTLY IN FORCE:

- RISULTA IN CONFORMITÀ CON QUANTO PREVISTO DALLE SEGUENTI DIRETTIVE CEE, COMPRESSE LE ULTIME MODIFICHE, E CON LA RELATIVA LEGISLAZIONE NAZIONALE DI RECEPIMENTO:
- DEN IN DEN FOLGENDEN EWG-RICHTLINIEN VORGEGEHEHENEN VORSCHRIFTEN, EINSCHLIEßLICH DER LETZTEN ÄNDERUNGEN, SOWIE DEN ANGEWANDTEN LANDESGESETZEN ENTSPRICHT:
- EST CONFORME AUX DIRECTIVES CEE SUIVANTES, Y COMPRIS LES DERNIÈRES MODIFICATIONS, ET À LA LÉGISLATION NATIONALE D'ACCUEIL CORRESPONDANTE:
- ES CONFORME A LAS SIGUIENTES DIRECTIVAS CEE, INCLUIDAS LAS ÚLTIMAS MODIFICACIONES, Y A LA RELATIVA LEGISLACIÓN NACIONAL DE RECEPCIÓN:

- 2014/35/EC low voltage directive
direttiva bassa tensione
Bestimmungen der Niederspannungsrichtlinie
directive basse tension
directiva de baja tensión
- 2014/30/UE electromagnetic compatibility
compatibilità elettromagnetica
Elektromagnetische Verträglichkeit
compatibilité électromagnétique
compatibilidad electromagnética
- 2009/125/CE Ecodesign /Progettazione ecocompatibile / Ecodesign / Éco-conception / Ecodiseño
- 2011/65/UE 2015/863/UE RoHS

-Unit manufactured and tested according to the followings Standards:
 -Unità costruita e collaudata in conformità alle seguenti Normative:
 -Unité construite et testée en conformité avec les Réglementations suivantes
 -Unidad construida y probada de acuerdo con las siguientes Normativas
 -Gebautes und geprüftes Gerät nach folgenden Normen

EN 60335-2-40 :2003+A11 :2004+A12 :2005+A1 :2006+A2 :2009+A13 :2012
 EN 60335-1 :2012+A11 :2014+A13 :2017+A1 :2019+A14 :2019+A2 :2019
 EN 62233 :2008
 EN 55014-1 :2017+A11 :2020 EN 55014-2 :2015
 EN IEC 61000-3-2 :2019 EN 61000-3-3 :2013+A1 :2019
 EN 61000-3-12 :2011 EN 61000-3-11 :2000
 EN 62321-1 :2013 EN 62321-2 :2014 EN 62321-3-1 :2014
 EN 62321-4 :2014 EN 62321-5 :2014 EN 62321-6 :2015
 EN 62321-7-1 :2015 EN 62321 :2009

-Responsible to constitute the technical file is the company n°.00708410253 and registered at the Chamber of Commerce of Belluno Italy
 -Responsabile a costituire il fascicolo tecnico è la società n° 00708410253 registrata presso la Camera di Commercio di Belluno Italia
 -Verantwortliche für die technischen Unterlagen zusammenstellen n°.00708410253 ist das Unternehmen bei der Handelskammer von Belluno Italien registriert
 -Responsable pour compiler le dossier technique est la société n°00708410253 enregistrée à la Chambre de Commerce de Belluno en Italie
 -Encargado de elaborar el expediente técnico es la empresa N ° 00708410253 registrada en la Cámara de Comercio de Belluno Italia

FELTRE,

20/09/2021

NAME / NOME / VORNAME / PRÉNOM / NOMBRE

SURNAME / COGNOME / ZUNAME / NOM / APELLIDOS

COMPANY POSITION / POSIZIONE / BETRIEBSPOSITION / FONCTION / CARGO

STEFANO

BELLÒ

LEGALE RAPPRESENTANTE





FOR 30 YEARS WE HAVE BEEN OFFERING
SOLUTIONS FOR SUSTAINABLE COMFORT
THE WELL-BEING OF PEOPLE AND
THE ENVIRONMENT

www.clivet.com

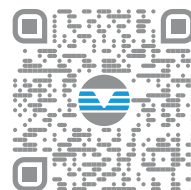

sales and service



CLIVET SPA
Via Camp Lonc 25, Z.I. Villapaiera
32032 Feltre (BL) - Italy
Tel. +39 0439 3131 - Fax +39 0439 313300
info@clivet.it

MideaGroup
humanizing technology