



OUTDOOR UNIT MINI VRF

400T-450T MSAN-XMi Series



INSTALLATION MANUAL
USE AND MAINTENANCE

MOMA40P16-02- 11/21

INTRODUCTION

Dear Customer,

Thank you for choosing a **CLIVET** product.

The model which you have chosen is a high performance product of advanced design and technology, high reliability and quality construction.

We suggest that you entrust its management and maintenance to professionally qualified personnel you trust, who, when necessary, only use original spare parts.

This manual contains important information and tips that must be followed for easier installation and the best possible use of the appliance.

SERIES

VRF systems	
MSAN-XMi unit	from 400T to 450T

SYMBOLS USED IN THE MANUAL AND THEIR MEANING



WARNING

To indicate special information.



CAUTION

To indicate particularly important and delicate operations.



CAUTION DANGER

To indicate actions which, if not carried out correctly, may result in general accidents or may cause malfunctions or material damage to the appliance; therefore, they require special attention and adequate preparation.



ATTENTION ELECTRIC DANGER

To indicate actions which, if not carried out correctly, may result in accidents of electrical origin; therefore, they require special attention and adequate preparation.



IT IS PROHIBITED TO

indicate actions that **MUST NOT** be performed.

WARRANTY

The product **CLIVET** is covered by a **conventional warranty**, valid from the date of purchase of the appliance, the conditions of which are specified in the GENERAL CONDITIONS OF SALE available at www.clivet.com



WARNING

- The warranty is void if the appliance has been used without following the instructions in this manual.
- The warranty will be forfeited if the customer makes changes and/or attempts to repair the product himself or through third parties not authorised by the manufacturer/authorised dealer.
- The product must be intended for the use intended by **CLIVET** for which it was expressly made. Any contractual and non-contractual liability **CLIVET** for damage caused to persons, animals or property by installation, adjustment, maintenance and misuse errors is excluded.

INDEX

1 General information	4	6 Starting up the system.....	38
1.1 General warnings and safety rules	4	6.1 Flushing the pipes	38
1.2 Description of system components	8	6.2 Gas leak test	38
1.3 Accessories	9	6.3 Vacuum operation	39
1.4 Identification	9	6.4 Charging with refrigerant	40
2 Preliminary indications	10	7 Special functions	44
2.1 Combinations of outdoor/indoor units	10	7.1 Configuration of the dip-switches	44
2.2 Unit dimensions	11	7.1.1 System control mode	47
2.3 Operating range	11	7.1.2 Error codes	48
2.4 Dimensions of the connection pipes	11	8 Start-up	50
2.5 Length of refrigerant piping	12	8.1 Start-up preparations	50
3 Installation	13	8.1.1 Checklist before running the test	50
3.1 Preliminary warnings	13	8.1.2 Information on performing the test	51
3.2 Handling	14	8.1.3 Rectifications after the test	51
3.3 Dimensions of the installation area	15	8.2 Commissioning	52
3.4 Requirements for installation in particular climatic conditions	16	8.3 Automatic addressing procedure for indoor units (400T to 450T)	52
3.5 Specifications for fixing	16	9 Maintenance.....	53
3.6 Outlets for the connection pipes and for the power supply line	17	9.1 Maintenance after shutting the unit down for a long period	54
4 Refrigerant piping.....	18	9.2 Maintenance before the unit is shut down for a long period	54
4.1 Installation of the refrigerant piping	18	10 Troubleshooting.....	55
4.1.1 Diameters of accessory connection pipes	20	10.1 Operating problems and possible causes	55
4.1.2 Refrigerant piping connection	20	10.2 Remote control operating problems and possible causes	56
4.1.3 Connect the shut-off valves	20	11 Disposal	57
4.1.4 Sizing of the refrigerant piping	22		
4.2 Thermal insulation of the pipes	28		
5 Electrical connections.....	30		
5.1 Preliminary information	30		
5.2 Power supply line	31		
5.3 Communication bus network	33		
5.4 Wiring method	35		

1 GENERAL INFORMATION

1.1 General warnings and safety rules



WARNING

- This manual is the property of CLIVET and reproduction or transfer to third parties of the contents of this document is prohibited. All rights reserved. It is an integral part of the product; make sure that it is always supplied with the appliance, even in case of sale/transfer to another owner, so that it can be consulted by the user or by personnel authorised to carry out maintenance and repairs.
- Read this manual carefully before using the appliance to ensure its safe operation.
- Periodically check the integrity of the power cable. If the power cable is damaged, it may only be replaced by the manufacturer or the local distributor who sold the appliance or by authorised maintenance and repair personnel.
- Installation must be in accordance with the IEC 61000-3-12 standard.
- The installation must be carried out by an authorised dealer or a qualified technician. Incorrect installation may cause water leakage, electric shock and fire, or cause the appliance to malfunction.
- The installation must be carried out according to the instructions provided. An incorrect installation may cause water leaks, electric shock or fire.
- Perform the installation using only the supplied accessories and parts specified. The use of non-standard components may cause water leakage, electric shock or fire and cause the unit to malfunction.
- Perform the installation taking into account any possible natural events such as strong winds, typhoons and earthquakes. The appliance could fall and be damaged as well as cause damage to property or physical injury.
- If installing in areas prone to thunderstorms, take measures to protect the appliance from lightning.
- Work on the refrigerant circuit must only be carried out by persons with a valid certification, issued by an accredited body, certifying their competence to handle refrigerants safely in compliance with the specifications in force in the sector.
- Use a vacuum pump with a non return valve to evacuate the system. Do not perform an air purge using refrigerant.
- Use deoxidised phosphorous copper piping for the refrigerant (seamless copper alloy piping and tubing). Keep the inner and outer surface of the pipes clean and free of contaminants.
- Store the piping indoors and keep both ends of the pipes sealed until it is time to flare or weld.
- Do not use any means other than those recommended by the manufacturer to accelerate the defrosting process or to clean the unit.
- The appliance must be placed in a room that does not contain any ignition sources (e.g. open flames, gas appliances or electric heaters).
- Weld the pipes purging with nitrogen to avoid oxidation.
- Keep the interconnection cable away from the copper pipe. The temperature of the refrigerant circuit is high.
- Note that the refrigerants are odourless.
- Use only the refrigerants indicated in the manual.
- Recharge the refrigerant when it is in the liquid state.
- After installation, verify that there are no refrigerant leaks.
- Do not touch the components of the refrigerant line during or immediately after operation of the appliance. There is a risk of burns or frostbite.
- Install the connection joints and manifolds referring to the installation manual.
- Install the drainage pipe according to the instructions in this manual. Incorrect draining can cause water seepage or flooding with possible damage to the home and other property.
- Insulate the piping to avoid condensation.

- The direction of the flow of liquid is indicated with words or symbols on the housing of the appliance.
- Always use the specified cables for all electrical work. Connect the cables securely and secure them in a stable manner to prevent the terminals from being damaged by external forces. Incorrect electrical connection may cause overheating conditions and may result in fire and electrocution.
- Install the electrical cables making sure that they are not taut. Otherwise, they could break or overheat causing smoke or fire.
- The cables must be arranged so that the control board cover can close properly. If the control board cover is not closed properly, corrosion may occur and the connection points on the terminals may become hot, ignite or cause electric shock.
- Always disconnect all power supply circuits before touching the terminals for any reason.
- It is advisable to install a Class B or F differential magnetothermic circuit breaker on the power supply line of the appliance.
- For electrical work, comply with the provisions of the national electrical code, local regulations, current regulations and the requirements contained in the installation manual. It is necessary to use an independent circuit and a single power supply socket. Do not connect other appliances to the same electrical outlet. Insufficient electrical capacity or faulty electrical installation may cause risk of electric shock or fire.
- Incorporate in the wiring an omnipolar isolator switch with a separation distance of at least 3mm between all poles and a residual current device (RCD) with a value greater than 10mA. Observe the domestic regulations.
- Replace the fuses only with others of the same value and technical characteristics.
- Install the appliance and its power cables at least one metre away from other electrical equipment in order to avoid interference or noise.
- The appliance must be stored in such a way as to prevent any mechanical damage.
- Consult a qualified technician for unit repair or maintenance.
- Do not modify or alter the safety or protection devices.
- Do not touch the appliance with wet or damp parts of the body as to do so could lead to electric shock.
- Make sure that the power is disconnected before performing any service or maintenance.
- If you notice any anomalies (e.g. a burning smell), stop the appliance, turn off the power switch and consult your dealer.
- Make sure that the air inlet and outlet are not blocked as this could trigger the protective device that stops the appliance.
- This appliance is intended for use on commercial premises by experienced or suitably trained users
- This appliance is designed to cool or heat spaces intended for the presence of human beings. It must not be used to cool or heat food, plants, animals, machinery, equipment or works of art.
- Install the appliance in such a way that the noise and heat it generates does not disturb people living in the vicinity and does not affect the growth of animals or plants.
- Read this manual carefully before using the appliance to ensure its safe operation.

**CAUTION DANGER**

- When connecting refrigerant piping, keep substances or gases other than the specified refrigerant from entering the unit. The presence of other gases or substances can reduce unit performance and cause an abnormal increase in pressure in the refrigeration cycle. This can lead to explosion hazards and resulting injuries.
- Install the unit on a stable stand that can support its weight. If the chosen stand cannot support the weight of the unit, or if the installation is not performed correctly, the unit may fall and cause injury and serious damage.
- Do not pierce or ignite the appliance.
- The appliance must be placed in a well-ventilated room whose dimensions correspond to those specified for operation.
- The product must be installed with earthing in accordance with the law to avoid the risk of electrocution. Do not connect the earth cable to gas or water mains, lightning rods or phone earth cables.
- Install an earthing connection switch. Failure to install this can result in electric shock.
- Do not operate the appliance if the protections have been removed.
- Do not install the unit:
 - in a location that can be exposed to combustible gas leaks. Any accumulation of combustible gas around the unit may cause a fire hazard;
 - near the coast (except in the case of corrosion resistant models);
 - near a source of hot water due to the presence of caustic gas in the air;
 - in the presence of strong electromagnetic waves;
 - in the presence of significant voltage flicker;
 - in the presence of acid or alkaline liquid that evaporates;
 - in the presence of flammable materials or gas.
- Wear the required PPE (protective gloves) during installation and maintenance. High pressure piping poses a risk of burns during operation.
- Measure the insulation resistance and make sure it is at least $1M \Omega$ once the wiring work is done.
- Do not use flammable paints, enamels, sprays or other products that may release flammable fumes or vapours near the appliance as they could cause fires.
- Do not install open flame units near the appliance. The heat released could ruin it.
- Do not insert your fingers between the fans during operation. This could lead to injury.
- Do not allow children to play near the unit as it may cause injury.



IT IS PROHIBITED TO

- Make changes and/or repair attempts to the product. Any repairs must be carried out by a qualified technician.
- Touch the appliance with wet, damp and/or barefoot body parts. If you notice current leakage that can be detected on contact with metal parts of the appliance, disconnect the switch, unplug it from the power supply socket and contact an authorised dealer.
- Disperse in the environment and leave within the reach of children the packaging material as it may be a potential source of danger. It must therefore be disposed of in accordance with current legislation.
- Use the same electrical outlet for other appliances. Incorrect or insufficient power supply may cause fire or electric shock hazard.
- Connect the electric air conditioner to the power supply before having finished wiring the power lines and pipes. Connect the cables of the outdoor unit and then those of the indoor unit.
- Perform maintenance in the rain. Electrical leakage, electric shock, short circuit, malfunction, smoke or fire may occur.



Notes on fluorinated gases

- This air conditioner contains fluorinated gas. For specific information on gas types and quantities, please refer to the plate found on the unit. It is always necessary to comply with national regulations regarding the use of gases.
- Installation, service, maintenance and repair of the unit must be performed by a qualified technician.
- The uninstallation and recycling of the product must be carried out by qualified technical personnel.
- If a leak detection device is installed in the system, it is necessary to check that there are no leaks at least every 12 months. When checking the unit for leaks, it is recommended to keep a detailed record of all inspections.
- Pay attention to the fact that refrigerant R410A is odourless.

1.2 Description of system components

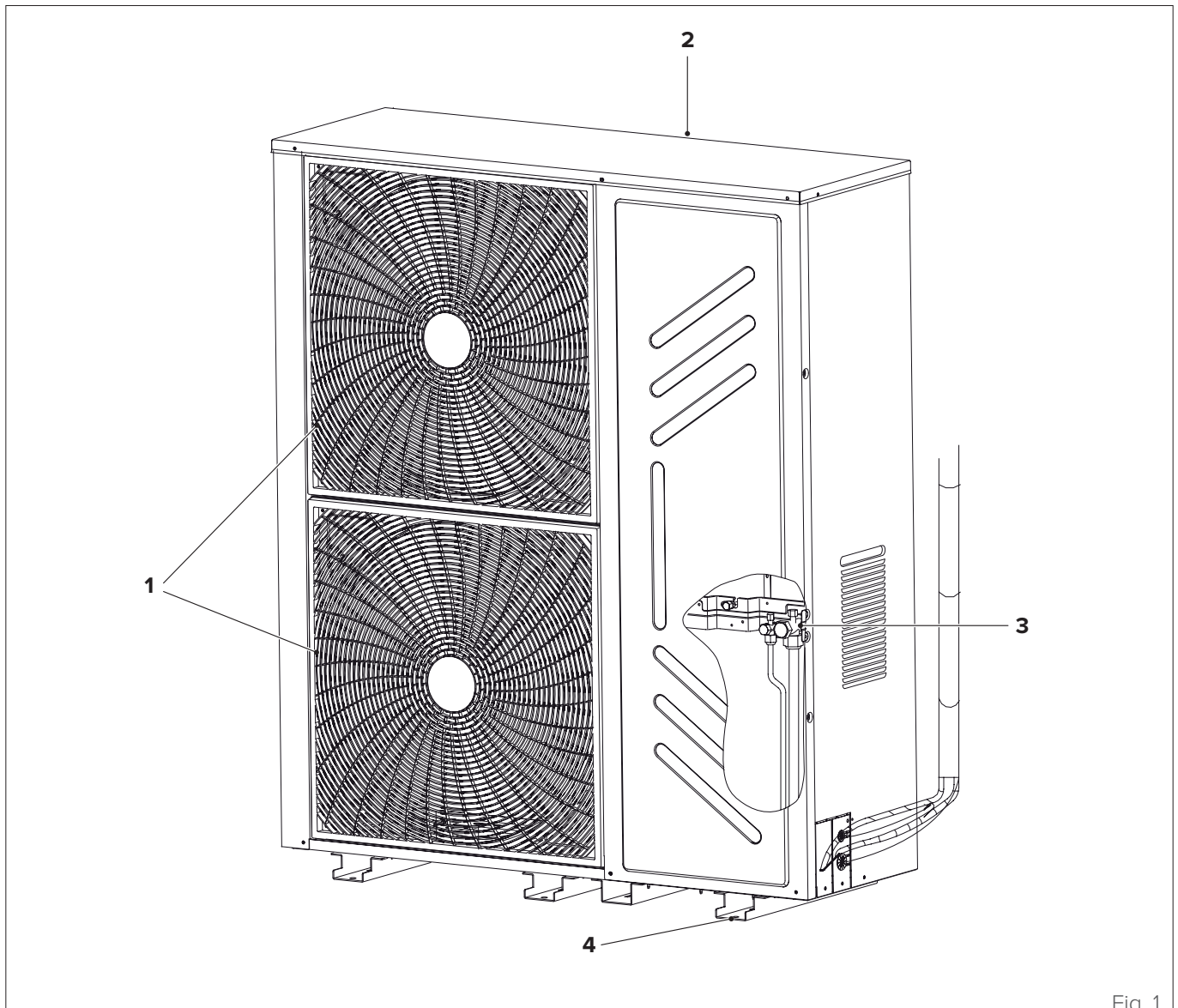

Fig. 1





- | | |
|--------------|---|
| 1 Air outlet | 3 Refrigerant pipe connector (internal fitting) |
| 2 Air inlets | 4 Fixed stand |

**WARNING**

The images in this manual are provided for illustrative purposes only. The appearance of your appliance may differ slightly from the illustrations shown here. Refer to the actual characteristics of the unit.

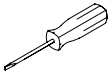
1.3 Accessories

The accessories are located at the top of the unit (e.g. the installation manual) or inside the unit, above the compressor (e.g. connecting pipe). The accessories in the unit are as follows:

Description	Aspect	Quantity
Flat blade screwdriver		1
Curved connecting pipe		1
Connecting pipe		1
Installation manual		1

1.4 Identification

The outdoor unit can be identified by the serial number label (1) that shows the technical and performance data of the unit and what is required by the legislation in force.

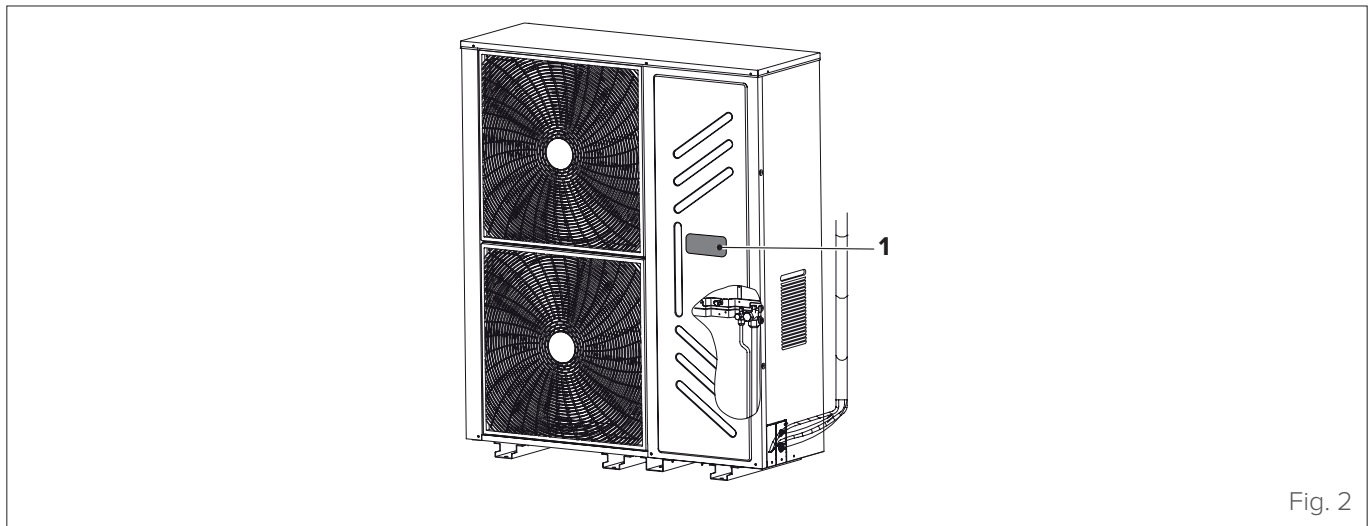

Fig. 2



CAUTION

Tampering, removal, lack of identification labels or anything else that does not allow safe product identification, makes any installation and maintenance operation difficult.

2 PRELIMINARY INDICATIONS

2.1 Combinations of outdoor/indoor units

Indicated in the table are:

- the maximum power obtainable (total power);
- the maximum quantity of indoor units that can be installed in relation to the power of the outdoor unit installed (Max indoor units).



WARNING

The total power of the indoor units must be the same or less than the power of the outdoor unit. Otherwise the cooling/heating effect would be compromised.

When all the indoor units of the system are not running at the same time, the maximum total power of the indoor units can reach 130% of the power of the outdoor unit.

If the system is used in an environment where there is an extreme climate (ambient temperature too high or below -10 °C), the total power of the indoor units must be less than the power of the outdoor unit.

Total power (kW)	Single unit power (kW)		Max indoor units	Total capacity of indoor units (power)
	400T	450T		
40	●		14	50%~130%
45		●	15	

2.2 Unit dimensions

400T - 450T

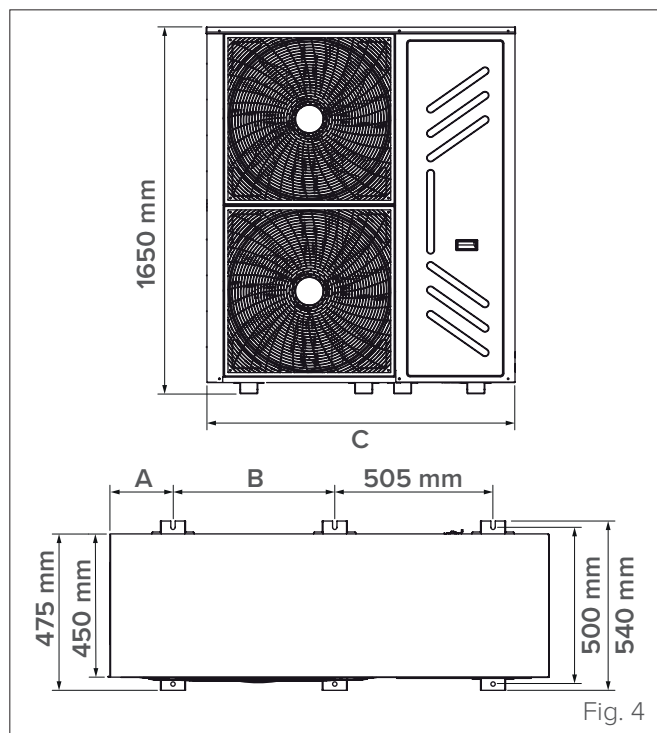

Fig. 4

Model	A	B	C
400T	175 mm	505 mm	1360 mm
450T	225 mm	555 mm	1460 mm

Model identification

Model	kW	Power supply
400T	40	400V + N Three-phase
450T	45	400V + N Three-phase

Indoor unit power index (kW)	Indoor unit cooling capacity (HP)
40	53
45	60

2.3 Operating range

The system is designed to function properly under the following climatic conditions:

Mode	Outdoor temp. °C	Indoor temp. °C	Relative indoor ambient humidity
Cooling	-5 to 48	21 to 32	< 80%
Heating	-15 to 24	0 to 28	/



WARNING

If the system is operated outside of the ranges indicated, the protection function is activated and the unit stops.

2.4 Dimensions of the connection pipes

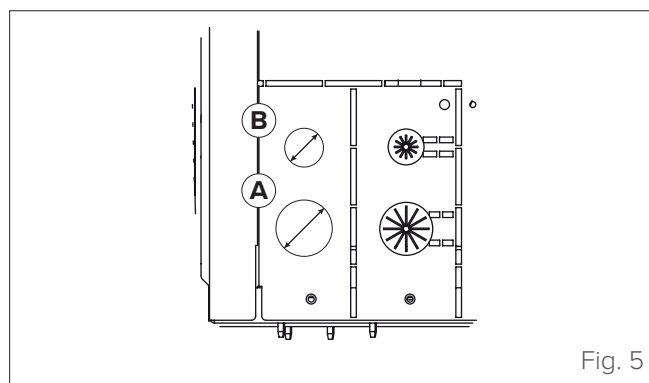

Fig. 5

Model	Ø (mm)	
	Gas side (A)	Liquid side (B)
400T	22.2	12.7
450T	25.4	

2.5 Length of refrigerant piping

In order to function correctly the system must take into account:

- the total length of the pipes (1);
- the maximum difference in height between the outdoor and indoor units (2) (3);
- the maximum lengths after the first Y-joint (4);
- the maximum difference in height between the indoor units (5).

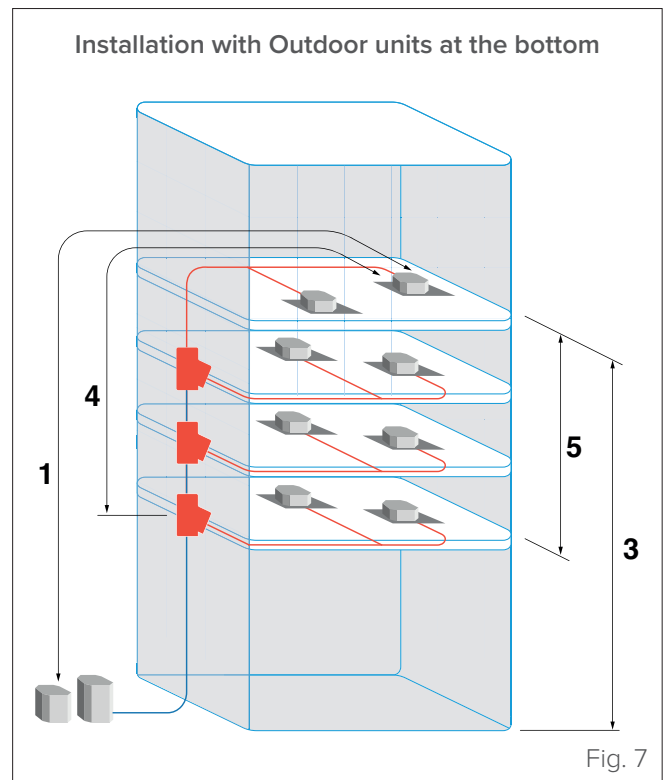
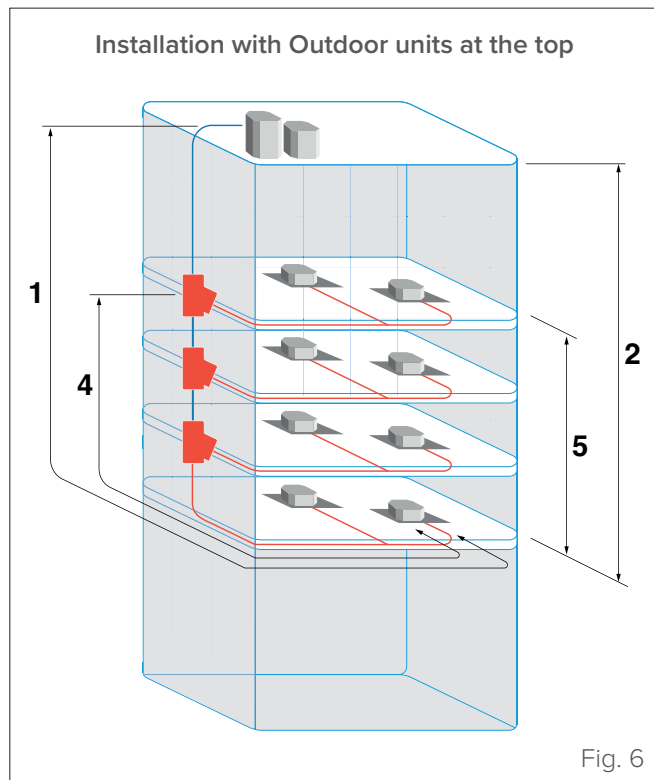

Ref.	Pipe length	Value
1	Total length of pipes	250m
2	Maximum difference in height between the outdoor unit (located at the top) and the indoor units	30m
3	Maximum difference in height between the outdoor unit (located at the bottom) and the indoor units	20m
4	Maximum length after first Y-joint.	40m
5	Maximum difference in height between indoor units	8m

3 INSTALLATION

3.1 Preliminary warnings



CAUTION

All installation operations must be carried out with the appliance completely stopped and after disconnecting all external power supplies.

Before any installation work, pay close attention to the labels on the appliance.

During the activities you must not tamper with or disconnect safety devices for any reason, create by-passes, or use them for purposes other than those envisaged by the manufacturer.

Below are the guidelines for achieving a compliant installation.

- Identify a suitable area for installation.**
See [“3.3 Dimensions of the installation area”](#) page 15
- Put the appliance in place.**
See [“3.5 Specifications for fixing”](#) page 16
- Lay the refrigerant piping.**
See [“4 Refrigerant piping”](#) page 18
- Perform correct installation of the condensate drain piping.**
- Clean the refrigerant piping.**
See [“6.1 Flushing the pipes”](#) page 38
- Make the refrigeration connections.**
See [“4.1 Installation of the refrigerant piping”](#) page 18
- Test the tightness of the system at the pressures indicated by the manufacturer.**
See [“6.2 Gas leak test”](#) page 38
- Carry out the correct pressurisation of the system.**
See [“6.3 Vacuum operation”](#) page 39
- Carry out the electrical wiring, configurations and addressing according to the diagrams provided.**
See [“5 Electrical connections”](#) page 30

Receiving the product

The appliance is supplied packed. Handling must be carried out by appropriate means in view of the overall weight of the package.

Upon receiving the appliance, check the perfect integrity of all parts.

Check that the model, specifications and quantity delivered conform to the order placed.

In case of damage to the appliance or missing material, please contact your authorised dealer promptly.

As far as possible, transport the packed unit to the place of final installation to avoid damage during handling.

Transport the appliance observing the following points:



Fragile. Handle with care.



Hold the unit with the front facing upwards to avoid damaging the compressor.



WARNING

The manual is an integral part of the product and therefore it is recommended that you read it before installing and commissioning the device and keep it with care for future reference or transfer to another Owner or User.

3.2 Handling

Transport, lifting and handling must be carried out with all due care. Improper use and failure to comply with the instructions will void the warranty.



WARNING

As the unit's centre of gravity is not the same as its physical centre, proceed with caution when lifting with straps.



WARNING

Do not support the outdoor unit by the intake opening to avoid possible deformation.



WARNING

Do not tilt it more than 45° and do not lay it on its side.

The areas set aside for handling and installing the appliance must be identified and inspected in advance in order to detect the presence of possible dangers.

The general rules for lifting and handling the appliance are given below

- Make sure that the safe working load of the lifting equipment is greater than the mass of the equipment to be lifted
- Take all necessary measures to ensure maximum stability of the load
- Handling must be performed smoothly, without jerking or sudden movements.

The appliance must be taken as close as possible to the place set aside for installation.

Remove all protection and packaging parts after handling.

If a forklift truck is used, make sure to insert the forks so that the load is balanced between them.

The packaging that covers the appliance and any straps or clamps securing parts of it must only be removed after handling at the site of use.

Before positioning the appliance, consider its overall dimensions and the space necessary for the operator's manoeuvres.

Remove and dispose of the packaging once the unit is in place.



IT IS PROHIBITED TO

disperse the packaging material in the environment and leave it within the reach of children as it can be a potential source of danger. It must be disposed of in accordance with current legislation.

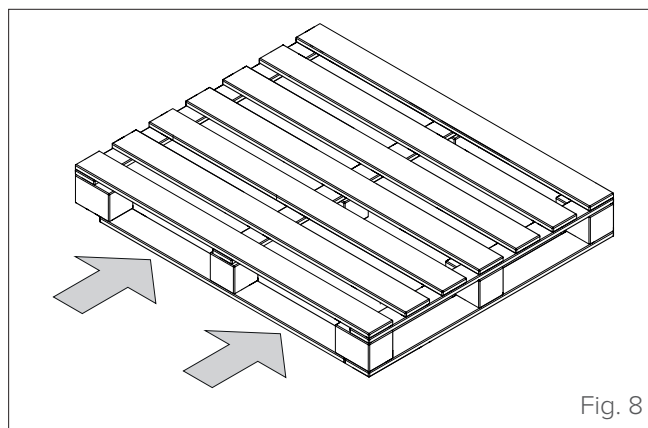

Fig. 8

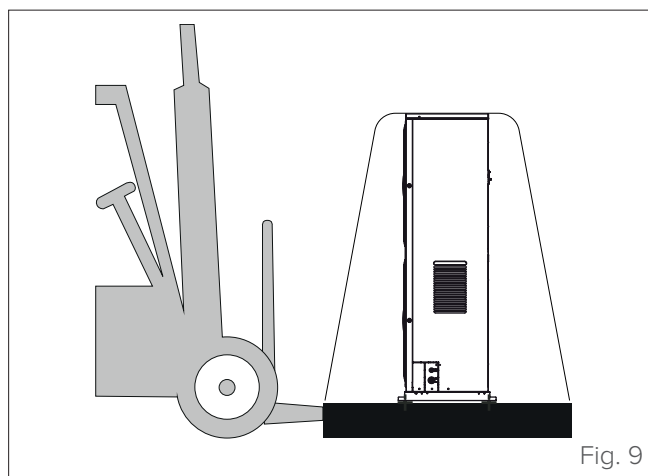

Fig. 9

The unit can be lifted using a crane and two straps. Handle the unit with care to avoid damaging it, and make a note of the position of the unit's centre of gravity.

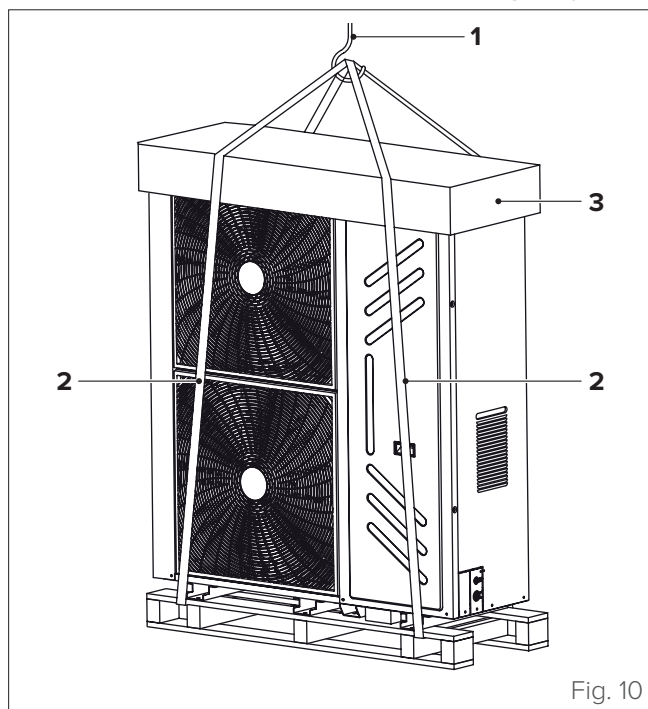

Fig. 10

- 1 Hook
- 2 Straps
- 3 Do not remove the packaging



WARNING

Use a strap that can withstand the weight of the unit.



WARNING

During all handling operations, use the appropriate PPE such as hard hat, gloves and safety shoes.



WARNING

Before use, remove the pieces of PE foam in the back of the unit that protect the condenser. Be careful not to damage the fins or the efficiency of heat exchange could be compromised.



It is PROHIBITED to install the outdoor unit in the following places:

- near an obstacle blocking the air inlets and outlets;
- near a public road, crowded areas or places where the noise from the unit may cause disturbance to others;
- near animals or plants that may be disturbed by the hot air coming out;
- where the hot air expelled by the outdoor unit can reach neighbours' windows;
- near combustible gas sources;
- in very dusty places;
- in places excessively exposed to salty air;
- in places with an oily atmosphere;
- in places with sulphur gas;
- in places where high-frequency radio waves may be generated, e.g. due to the presence of audio equipment, welding machines and medical devices;
- on uneven bases or surfaces that cannot withstand the weight of the unit.



WARNING

Install the indoor unit, the outdoor unit, the power cable and the connection cable at least 1 metre away from televisions or radios to avoid interference with the sound or images.

3.3 Dimensions of the installation area

The appliance must be installed in such a way that a sufficient amount of air can flow through the unit itself. When installing a single unit, the following distances must be observed:

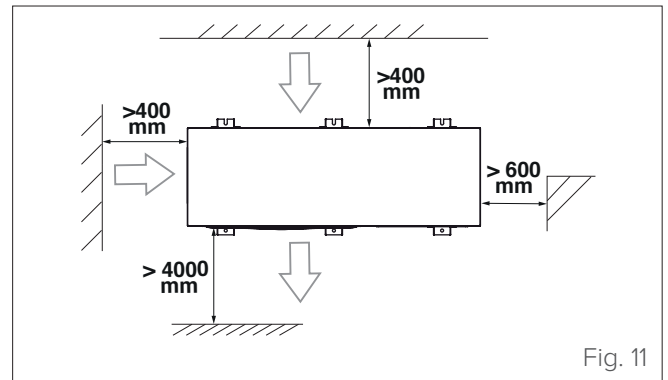

Fig. 11

If several appliances are installed in a line (independent), the following distances must be observed:

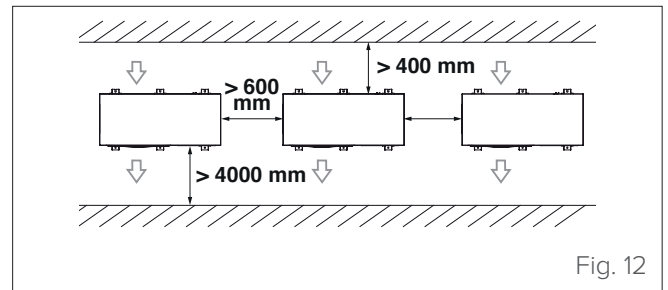

Fig. 12

If the front and rear sides are connected in parallel, observe the following distances:

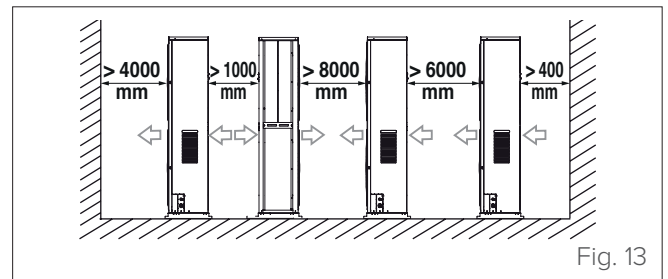

Fig. 13

3.4 Requirements for installation in particular climatic conditions

In the event of frequent snowfall, install a snow screen. Install the unit raised off the ground. Prevent snow from obstructing the coils.

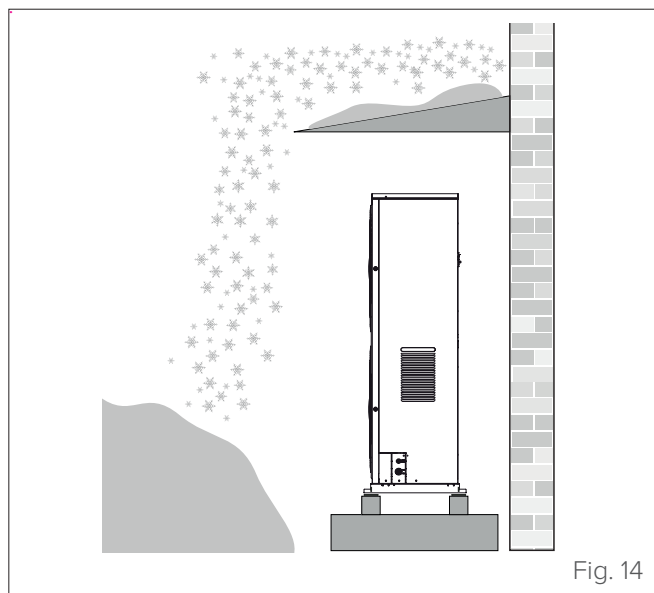

Fig. 14



CAUTION

Do not obstruct the air flow of the unit when installing the snow screen.

In places with strong winds, provide windbreaks.

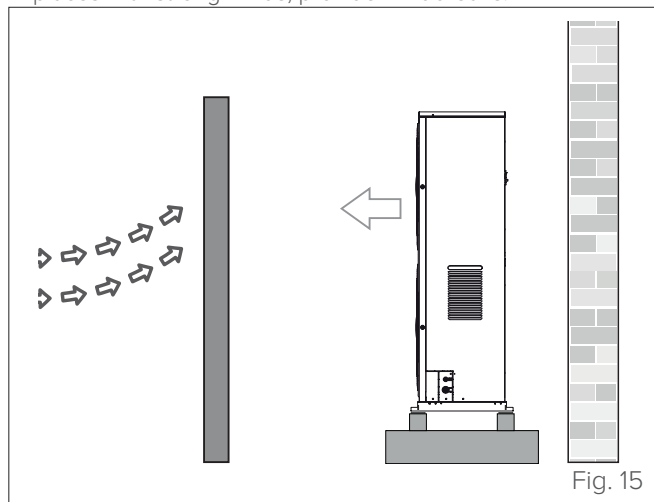

Fig. 15

If the unit is installed in a place regularly exposed to strong winds, such as on a building roof, make sure that the air outlet faces the wall. Keep the unit at least 4000 mm away from the wall.

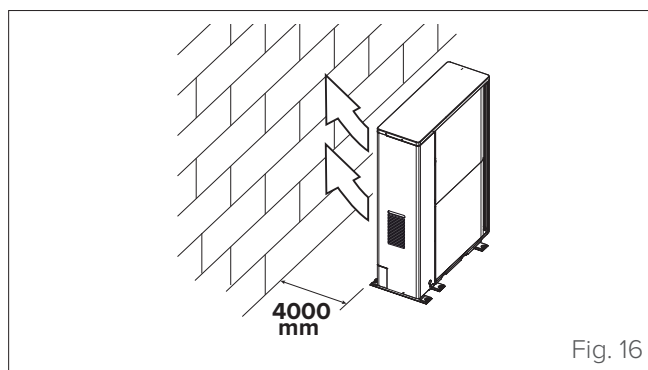

Fig. 16

Considering the wind direction in the season of use, direct the air outlet at a right angle to the wind direction.

3.5 Specifications for fixing

The outdoor unit must be installed on a support base (2) with the following characteristics:

- It must be placed on solid ground (1) or on structures capable of supporting its weight;
- It must be made of concrete or steel;
- It must have a minimum height of 200mm and a minimum thickness of 80mm (see figure in point 2). These dimensions allow for sufficient access during installation of the piping;
- It must have rounded edges;
- It must be perfectly level and the support points must withstand the weight of the unit evenly.

Keep at least 600 mm from a wall above the appliance. For fixing, use 10 mm diameter expansion anchors (3) and rubber anti-vibration pads (4).

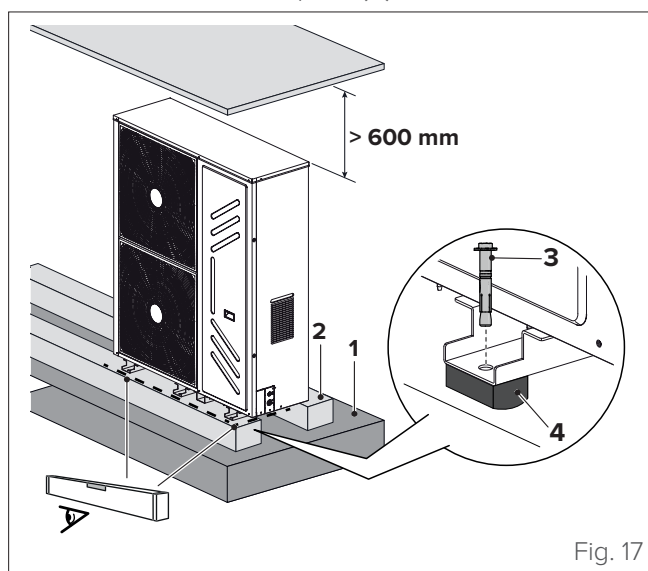

Fig. 17



CAUTION

When drilling holes. It is recommended to always use eye protection.

- Mark the positions of the four expansion anchors according to the measurements shown in the following table.
- Drill the holes for the expansion anchors.
- Remove any dust in the holes.
- Insert a nut on the end of each expansion anchor.
- Hammer the expansion anchors into the holes made.
- Remove the nuts from the expansion anchors and place the outdoor unit on the anchors.
- Insert the rubber pads on each expansion anchor and reapply the nuts.
- Using a spanner, tighten the nuts firmly.

The location of the fixing holes in the appliance is indicated in the table below:

Ref.	Model	
	400T	450T
A	1360 mm	1460 mm
B	505 mm	555 mm
C	505 mm	
D	500 mm	
E	540 mm	

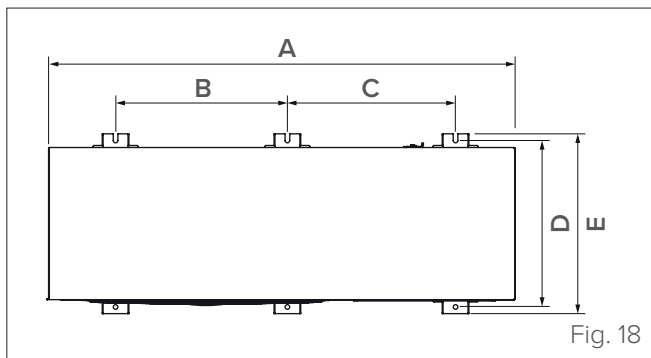

Fig. 18

- (A) Width of appliance
- (B) Location of holes on long side - pt.1
- (C) Location of holes on long side - pt.2
- (D) Depth of appliance
- (E) Location of holes on short side

The condensate water can freeze; create a drainage channel around the base to ensure the flow of water

3.6 Outlets for the connection pipes and for the power supply line

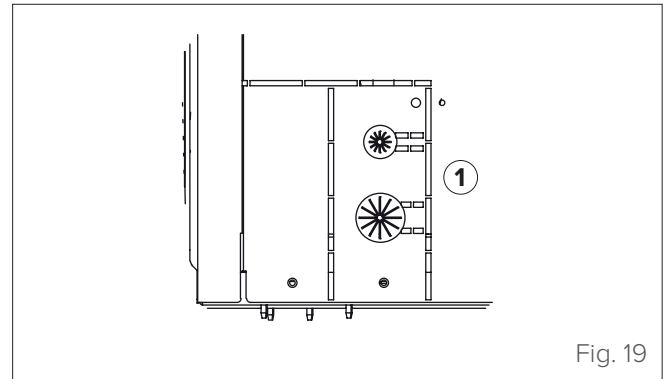

Fig. 19

- 1 Side outlet

4 REFRIGERANT PIPING

4.1 Installation of the refrigerant piping

Below are the guidelines for compliant installation of the refrigerant piping

- Put the outdoor unit in place
- Put the indoor unit in place
- Put the pipes in place
- Blow with nitrogen
- Perform welding
- Make the connection to the units
- Perform the tightness test
- Carry out pressing and pressurisation

To perform all the operations correctly, you need the following equipment:

- Pipe cutter
- Flaring tool
- Tube bending machine
- Vacuum pump
- Digital vacuum gauge
- Manifold and fittings
- Cylinder of nitrogen
- Electronic leak detector with sensitivity according to current regulations.



WARNING

Pay attention to the maximum measurements of the refrigerant piping. See paragraph “2.5 Length of refrigerant piping” page 12 .



WARNING

Use deoxidised phosphorous copper piping for the refrigerant (seamless copper alloy piping and tubing) compliant with local regulations.



WARNING

Use piping suitable for use with R410A.



WARNING

Be careful not to touch the components when connecting the pipes.

Keep the ends of the pipes sealed until installation to prevent the ingress of polluting agents such as dust, water and dirt.

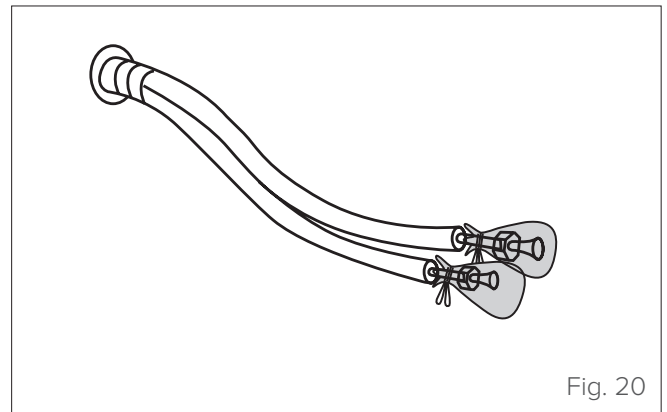

Fig. 20

For the diameter to be used refer to the following table

Ø (mm)	Ø (inches)	Radial thickness (mm)
6.35	1/4"	0.8
9.52	3/8"	0.8
12.7	1/2"	0.8
15.9	5/8"	1.0
19.1	3/4"	1.0
22.2	7/8"	1.2
25.4	1"	1.2
28.6	1" - 1/8"	1.3
31.8	1" - 1/4"	1.5
38.1	1" - 3/8"	1.5
41.3	1" - 5/8"	1.5
44.5	1" - 3/4"	1.5
54.0	2" - 1/8"	1.8

Blow nitrogen through the sections pre-welded in the workshop to expel any dust.

Pipes should only be cut using roller pipe cutters (do not use a hacksaw).

Dirt that penetrates the pipes when in use could clog the expansion valves, the capillaries or enter the compressor, causing the latter to malfunction.

Refrigerant piping

Eliminate any residual moisture in the lines. Copper plating, formation of acid sludge, freezing of the laminating devices, formation of acids that corrode metals and deteriorate the insulation of the electric motor can occur in the case of non-compliant installation with the presence of moisture. See paragraph [“6.3 Vacuum operation”](#) page 39

Avoid weld undercutting that cannot be inspected; all the piping must be accessible for inspection.



CAUTION

To prevent the refrigerant pipes from oxidising during welding, charge with nitrogen.

In case of laying the lines before making the connection to the units, keep the ends sealed until the time of connection.

It is good practice to pinch the ends in case the lines are laid a long time before the connection.



CAUTION

Use only nitrogen as a cleaning agent.

If residual moisture is found when cleaning with the blowing of nitrogen, or if a long time has passed between the laying of the lines and the connection, proceed with the "triple vacuum".

This procedure consists in filling with nitrogen and emptying twice before carrying out the final emptying operation.

Make sure that the pressure does not rise during this operation.

It is important that the joints are created to standard to ensure a good seal.

For more information see paragraph [“6.1 Flushing the pipes”](#) page 38 and [“6.2 Gas leak test”](#) page 38



WARNING

For connection of the lines, only "brazing" welding is allowed.

Brazing (1) consists in connecting metal pieces with the help of a filler metal without melting the pieces to be assembled. The filler metal penetrates by capillarity between the pieces to be assembled.

The filler metal must be phosphorous copper or "rods of silver alloy".

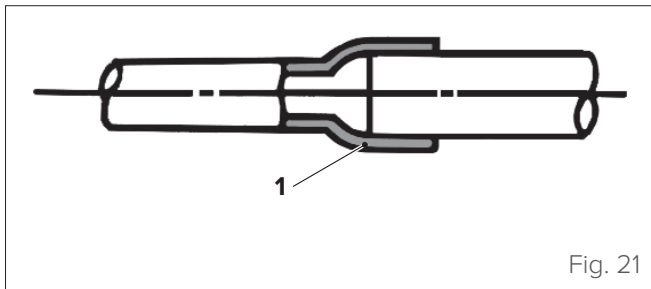

Fig. 21

Welding must be done in a neutral atmosphere (nitrogen). An inert atmosphere (free of moisture and oxygen) must be created inside the pipeline. In this way, no oxide formations are created during welding

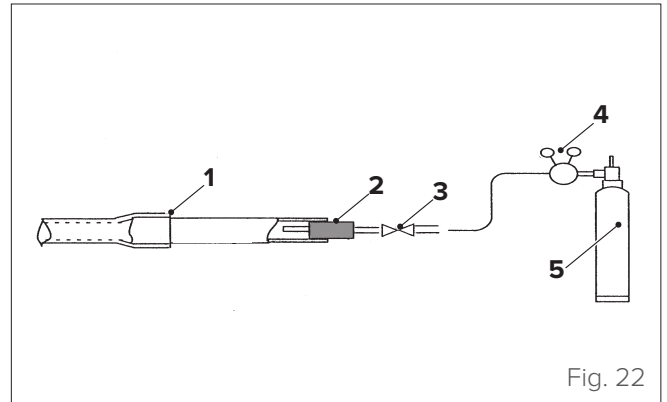

Fig. 22

- 1 Weld point
- 2 Rubber cap
- 3 Pressure reducer (operating pressure 0.2/0.5bar)
- 4 Pressure reducer on the cylinder
- 5 Cylinder of nitrogen

Connection method

	Gas side	Liquid side
Indoor unit	Flaring	Flaring
Outdoor unit	Welding or flaring	Welding or flaring
Branch pipe	Welding or flaring	Welding or flaring

If it is necessary to bend the piping, the risk of excessive deformation must be avoided. The maximum deformation allowed is 2/3rds of the diameter of the pipe itself.

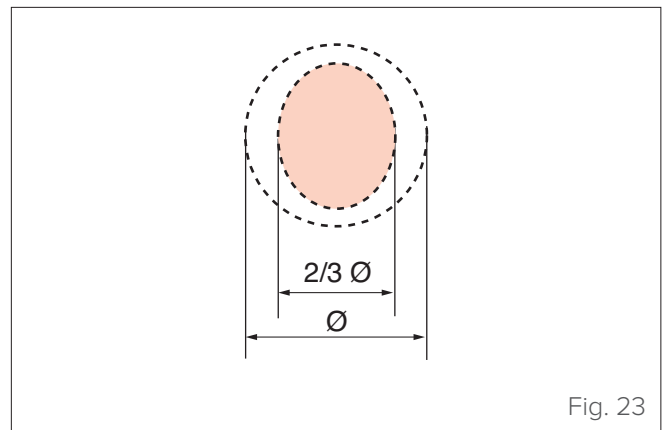

Fig. 23

Pipes can be bent respecting the following bending radii:

Pipe diameter (mm)	Radius (mm)
9.52	≥ 30
12.7	≥ 30
15.9	≥ 40
19.1	≥ 50

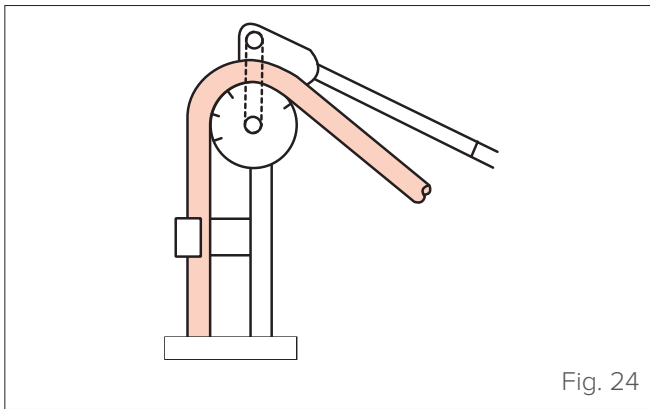

Fig. 24



CAUTION

Do not use or integrate existing pipes. The old refrigerant and oil in the piping contain a large amount of chlorine which will cause the fluid in the new unit to deteriorate.



WARNING

Do not use solenoid valves to avoid the backflow of oil.

4.1.1 Diameters of accessory connection pipes

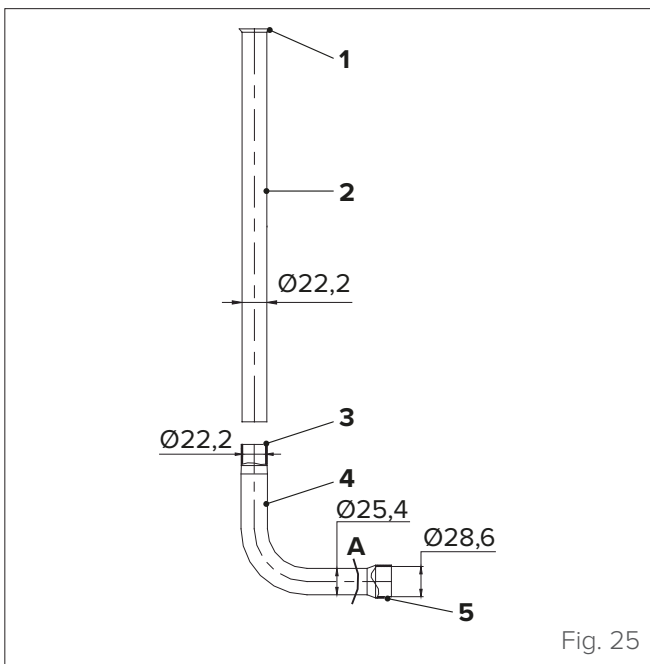

Fig. 25

- 1 Flaring (connection to the gas side shut-off valve)
- 2 Accessory connection pipe
- 3 Connect this end to the accessory connection pipe
- 4 Accessory for elbow connection
- 5 Connect this end to the main pipe

Elbow connection instructions

Diameter of the main connection pipes	Pipe bending method
Ø22.2	Cut the pipe at A, insert the main pipe and weld
Ø25.4	Cut the pipe at A, flare and weld
Ø28.6	Directly insert the main pipe and weld

4.1.2 Refrigerant piping connection

Remove the front panel in order to: connect the refrigerant piping, make the electrical connections and carry out maintenance on the unit.



WARNING

Before connecting the pipes to the outdoor unit, check that they do not contain water or contaminants. Flush the pipes with high pressure nitrogen, do not use refrigerant from the outdoor unit under any circumstances.

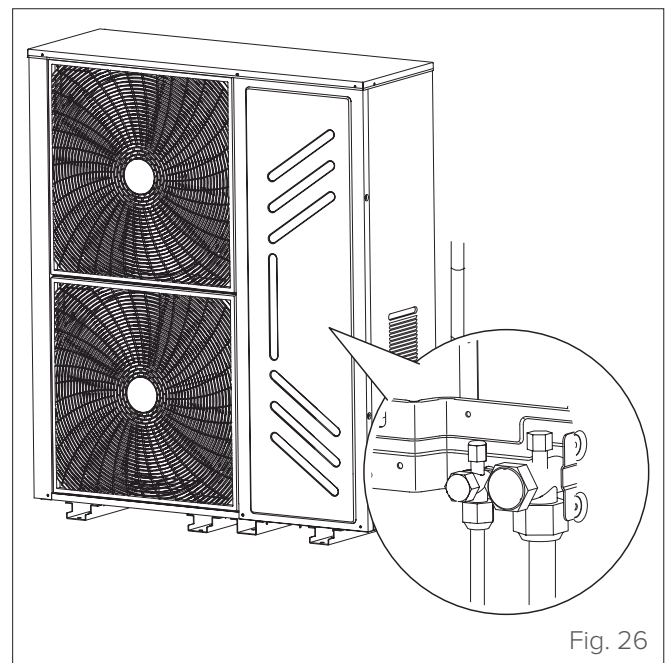

Fig. 26



WARNING

After connecting the pipes to the indoor and outdoor units, charge with pressurised nitrogen to perform a tightness test.

4.1.3 Connect the shut-off valves

Stop valve

The stop valves are closed when the unit is shipped from the factory.

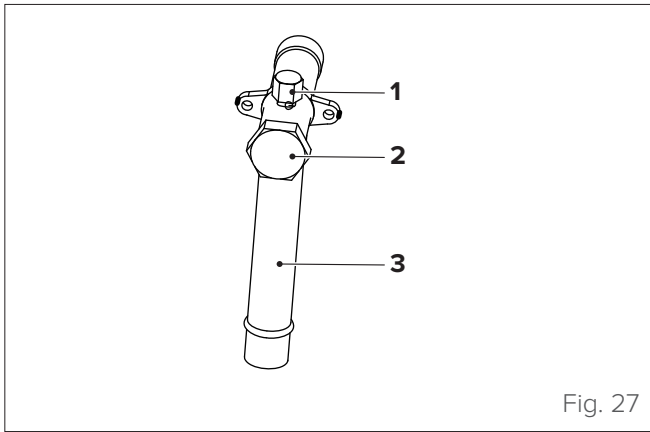

Fig. 27

- 1 Access for maintenance and cover of the valve
- 2 Cover of the stop valve
- 3 Connecting pipe of the stop valve

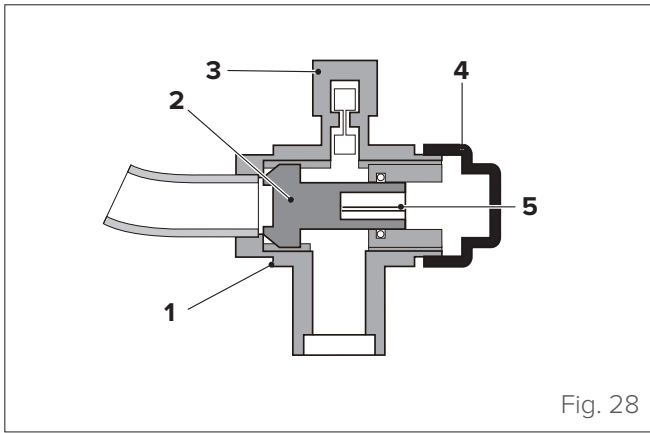

Fig. 28

- 1 Seal component
- 2 Axis
- 3 Access for maintenance
- 4 Cover of the stop valve
- 5 Hexagonal hole

Use of the stop valve

- 1 Remove the cover of the stop valve.
- 2 Insert the hexagonal wrench in the shut-off valve and turn the shut-off valve anti-clockwise.
- 3 Stop rotation when the stop valve cannot be turned any further.
- 4 The valve is now open.

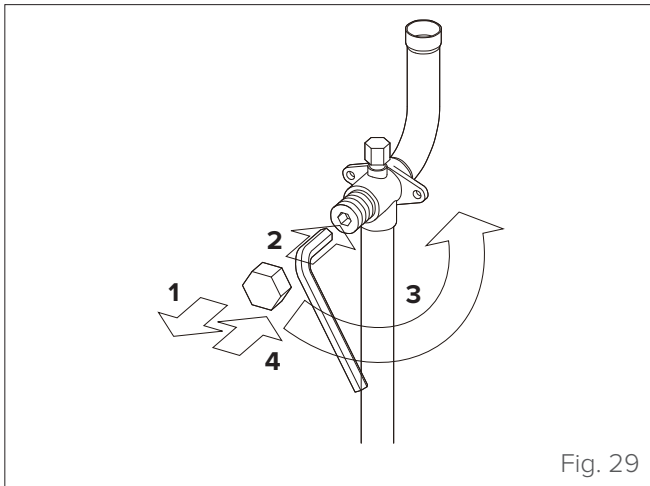

Fig. 29



CAUTION

Insufficient torque can cause the leaking of refrigerant.

Size of the stop valve (mm)	Tightening torque/N.m. (Turn clockwise to close)	
	Axis	
	Valve body	
Ø6.4	14.2 ~ 17.2	
Ø9.5	32.7 ~ 39.9	
Ø12.7	49.5 ~ 60.3	
Ø15.9	61.8 ~ 75.4	
Ø19.1	97.2 ~ 118.6	
Ø22.2	109.5 ~ 133.7	

Specifications for the shut-off valve

Model	40kW	45kW
Liquid side shut-off valve	Ø12.7	Ø12.7
Gas side shut-off valve	Ø22.2	Ø25.4

Closing of the stop valve

- 1 Remove the cover of the stop valve.
- 2 Insert the hexagonal wrench in the shut-off valve and turn the shut-off valve clockwise.
- 3 Stop rotation when the stop valve cannot be turned any further.
- 4 The valve is now closed.

Direction of closing:

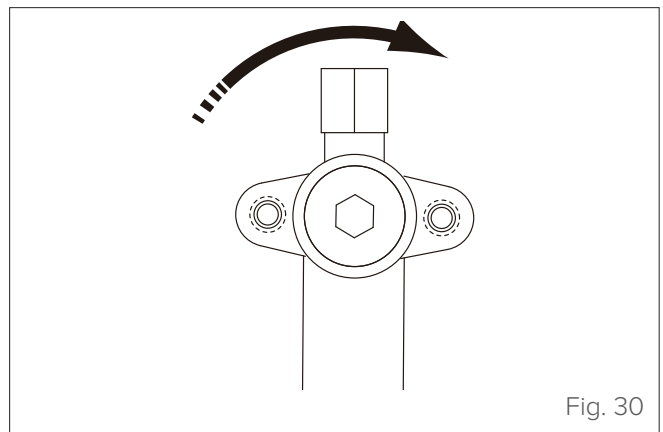

Fig. 30

4.1.4 Sizing of the refrigerant piping

			Allowed value	Piping
Pipe length	Total length of pipes (Total extended length)		250 m	$L_1+L_2+L_3+L_4+L_5+a+b+c+d+e+f$
	Maximum pipe length (L)	Effective length	≤ 100 m	$L_1+L_2+L_3+L_4+L_5$ (first connection method)
		Equivalent length	≤ 120 m	$L_1+L_3+L_5+f$ (second connection method)
	Pipe length (between the furthest indoor unit and the first branch joint)		≤ 40 m	$L_2+L_3+L_4+L_5+f$ (first connection method) L_3+L_5+f (second connection method)
Equivalent pipe length (equivalent length of the nearest branch)		≤ 15 m	a,b,c,d,e,f	
Level difference	Difference in level between indoor/outdoor unit	Outdoor unit up	≤ 30 m	
		Outdoor unit down	≤ 20 m	
	Difference in height between indoor units		≤ 8 m	

Note: when the total equivalent length of the pipes on the liquid + gas sides is ≥ 90 m, the size of the main pipe on the air side must be increased. Moreover, depending on the distance of the refrigerant pipe and the condition of the corresponding indoor unit, the size of the main pipe on the gas side can be increased when the capacity decreases.

Choice of connection method

If the distance between the first branch and the last indoor unit is more than 15 m, choose the second connection method. The pipe between the indoor unit and the nearest branch must be less than 15 m long.

First connection method

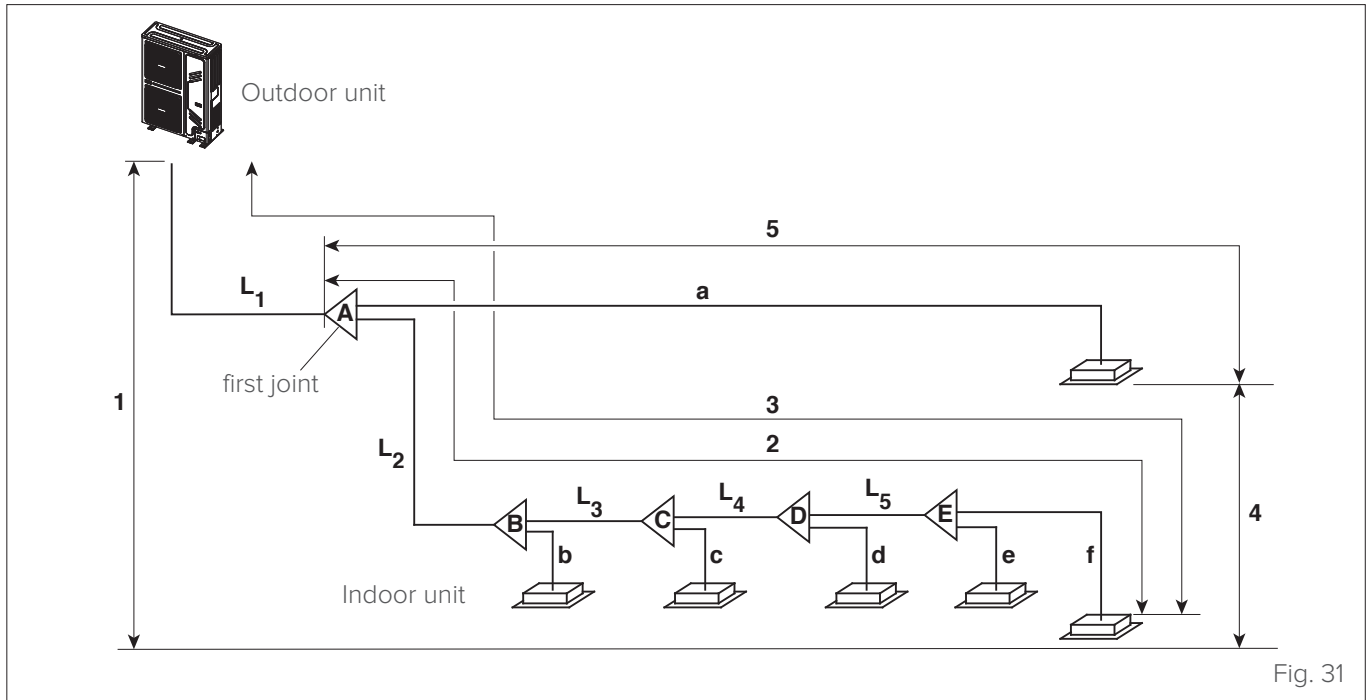

Fig. 31

Ref.	Pipe length	Value
1	Maximum difference in height between outdoor units (located at the top) and indoor units	30m
	Maximum difference in height between outdoor units (located at the bottom) and indoor units	20m
2	Pipes between the furthest indoor unit and the first indoor branch	40m
3	Maximum equivalent length of the pipe between the outdoor unit and the furthest indoor unit	120m
4	Maximum difference in height between indoor units	8m
5	Equivalent pipe length from the first branch to the nearest indoor unit	15m

Ref.	Description
L1	Main pipe
L1 L5	Internal main pipes
a f	Internal auxiliary pipes
A E	Internal branch joints

Second connection method

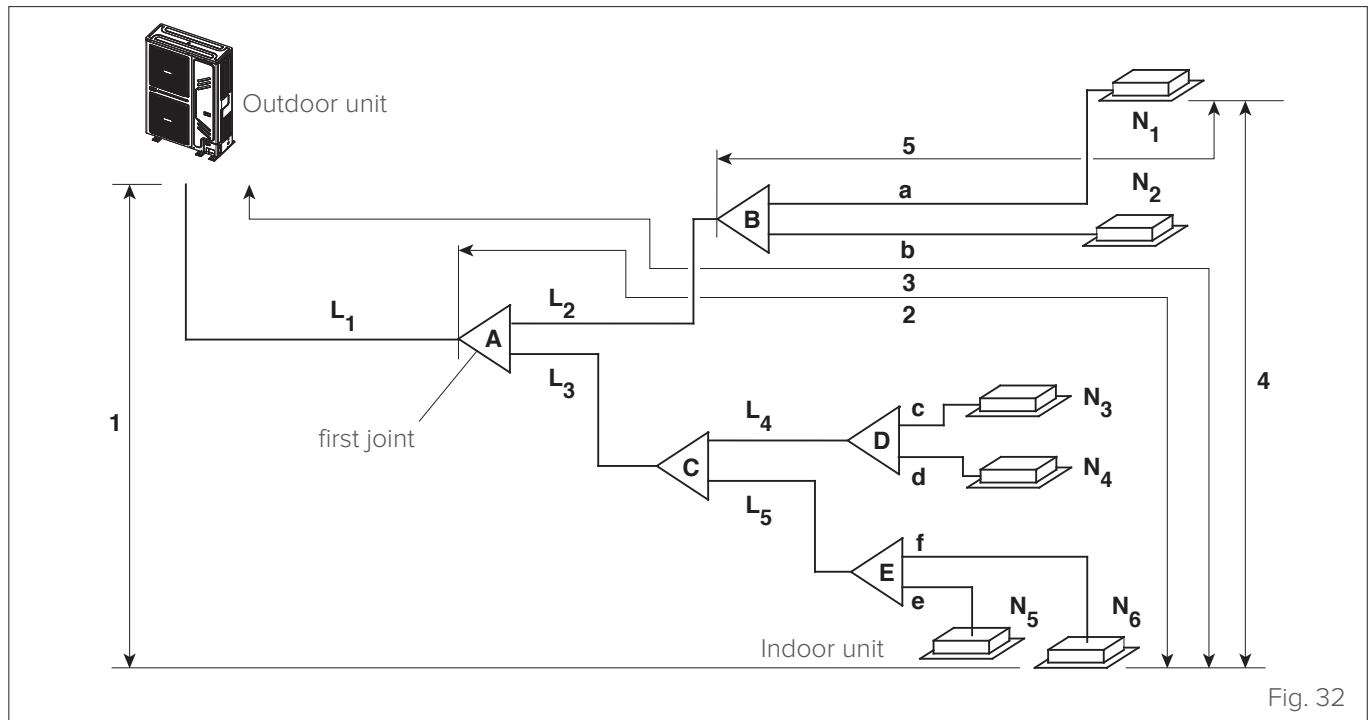
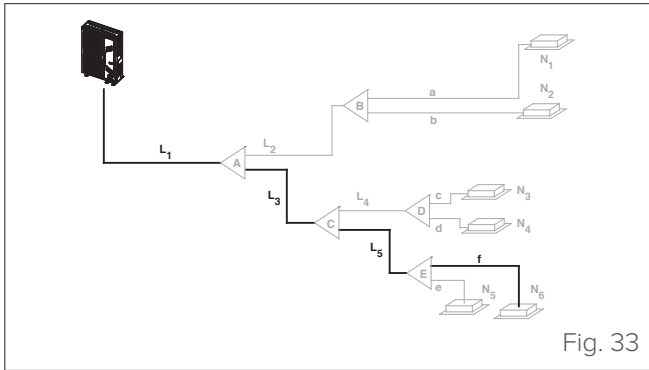

Fig. 32

Ref.	Pipe length	Value
1	Maximum difference in height between outdoor units (located at the top) and indoor units	30m
	Maximum difference in height between outdoor units (located at the bottom) and indoor units	20m
2	Pipes between the furthest indoor unit and the first indoor branch	40m
3	Maximum equivalent length of the pipe between the outdoor unit and the furthest indoor unit	120m
4	Maximum difference in height between indoor units	8m
5	Equivalent pipe length from the first branch to the nearest indoor unit	15m

Ref.	Description
L1	Main pipe
L1 ... L5	Internal main pipes
a ... f	Internal auxiliary pipes
A ... E	Internal branch joints
N1 ... N6	Indoor units (the power in kW in brackets)

The maximum length of the connection pipes between the branch joint and the furthest indoor unit must not exceed 40m.



WARNING

The length of each branch joint is 0.5m. The indoor units should be as similar as possible to permit installation of the branch joint on both sides.



CAUTION

The length of the piping between the furthest indoor unit and the first internal branch joint must not exceed 15m.



WARNING

There must be at least 0.5 m of piping after a bend and before a branch.



WARNING

The linear distance between adjacent branch pipes must be at least 0.5 m;



WARNING

The linear distance between the branch pipes and the indoor unit must be at least 0.5 m;



WARNING

The branch manifold must be connected directly to the indoor units, no additional branch is permitted.

- Each internal auxiliary pipe must not be more than 15m away from the internal branch joint (e.g. L5 and f)
- The difference in length between the internal main pipe (e.g. L5) from the first internal branch joint (e.g. A) of the furthest indoor unit (e.g. N6) and the internal main pipe (e.g. L2) of the first internal branch joint (e.g. A) of the nearest indoor unit (e.g. N1) does not exceed 40m.

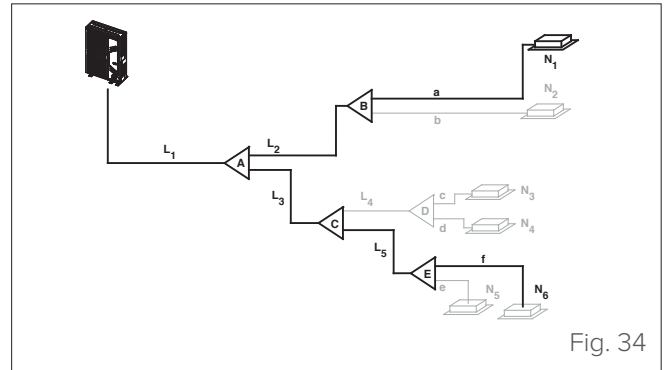

CAUTION

If you exceed 40m, increase the diameter of the internal main pipes by one size. Perform this operation only for pipes that are smaller than the main pipe.

Choice of branch joint

Select the type of branch joint according to the total capacity of the indoor units to be connected.

If this capacity is higher than that of the outdoor unit, choose the connection according to the outdoor unit.

The choice of the branch joint depends on the number of branches to be connected.

Use of branch joints

The branch joints must be installed at a maximum horizontal angle (α) of 10° to avoid uneven distribution of the refrigerant.

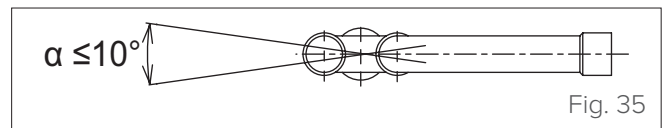

Selection of kits with main pipe (L1), internal main pipes (L2 to L5) and internal branch joint

The dimensions of the main pipe and of the internal main pipes are indicated in the following table. Use the specified branch joint kit. Use only pipes with the dimensions indicated.

Total power of indoor units	Gas side (Ø mm)	Liquid side (Ø mm)	Branch joint kit
< 16.6	15.9	9.5	FQZHN-01C
16.6 to 23	19.1	9.5	FQZHN-01C
23 to 33	22.2	9.5	FQZHN-02C
33 to 46	25.4	12.7	FQZHN-02C
≥ 46	25.4	12.7	FQZHN-02C

Table 1

Selection of main pipe (L1) and first internal branch joint (A)

If the equivalent length of all liquid pipes is **less than 90m**, use only the measurements of the main pipe and of the internal main pipes indicated in the following table. Use the specified branch joint kit. Use only pipes with the dimensions indicated.

Total capacity of outdoor unit (kW)	Gas side (Ø mm)	Liquid side (Ø mm)	Branch joint kit
40	22.2	12.7	FQZHN-02C
45	25.4	12.7	FQZHN-02C

Table 2

If the equivalent length of all liquid pipes is **more than 90m**, use only the measurements of the main pipe and of the internal main pipes indicated in the following table. Use the specified branch joint kit. Use only pipes with the dimensions indicated.

Total capacity of outdoor unit (kW)	Gas side (Ø mm)	Liquid side (Ø mm)	Branch joint kit
40	25.4	12.7	FQZHN-02C
45	28.6	12.7	FQZHN-03C

Table 3

Selection of internal auxiliary pipes

The internal auxiliary pipes (a...f) must respect the diameter indicated in the table, based on the overall power of the indoor units.

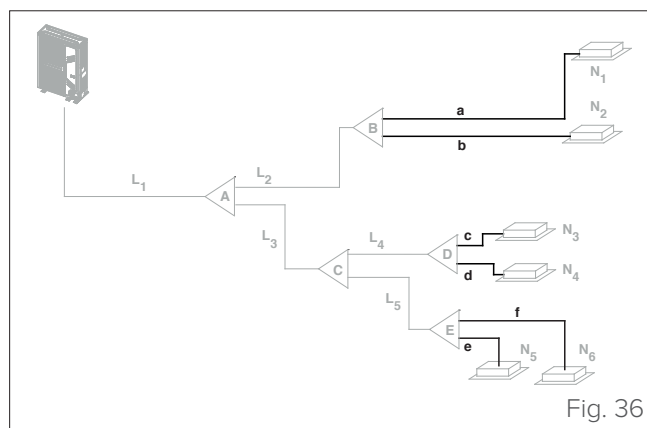

Fig. 36

Model	Gas side (Ø mm)	Liquid side (Ø mm)
wall 22 ~ 45	12.7	6.4
wall 56	15.9	9.5
4-way cassettes 28 ~ 45	12.7	6.4
4-way cassettes 56 ~ 80	15.9	9.5
1-way cassettes 18 ~ 45	12.7	6.4
1-way cassettes 56	15.9	9.5
Ductable with low head 18 ~ 45	12.7	6.4
Ductable with low head 56	15.9	9.5
Ductable with low head 71	15.9	9.5
Ductable with medium head 22~45	12.7	6.4
Ductable with medium head 56~80	15.9	9.5
Ductable with medium head 90~140	15.9	9.5

Table 4

EXAMPLE OF SIZING OF REFRIGERANT PIPING

The example below illustrates the piping selection procedure for a system consisting of one outdoor unit (45kW) and 6 indoor units. The equivalent length of all the liquid pipes is greater than 90m; the pipe between the furthest indoor unit and the first junction of the indoor joints is less than 40m; each internal auxiliary pipe (from each indoor unit to the nearest joint) is less than 8m in length.

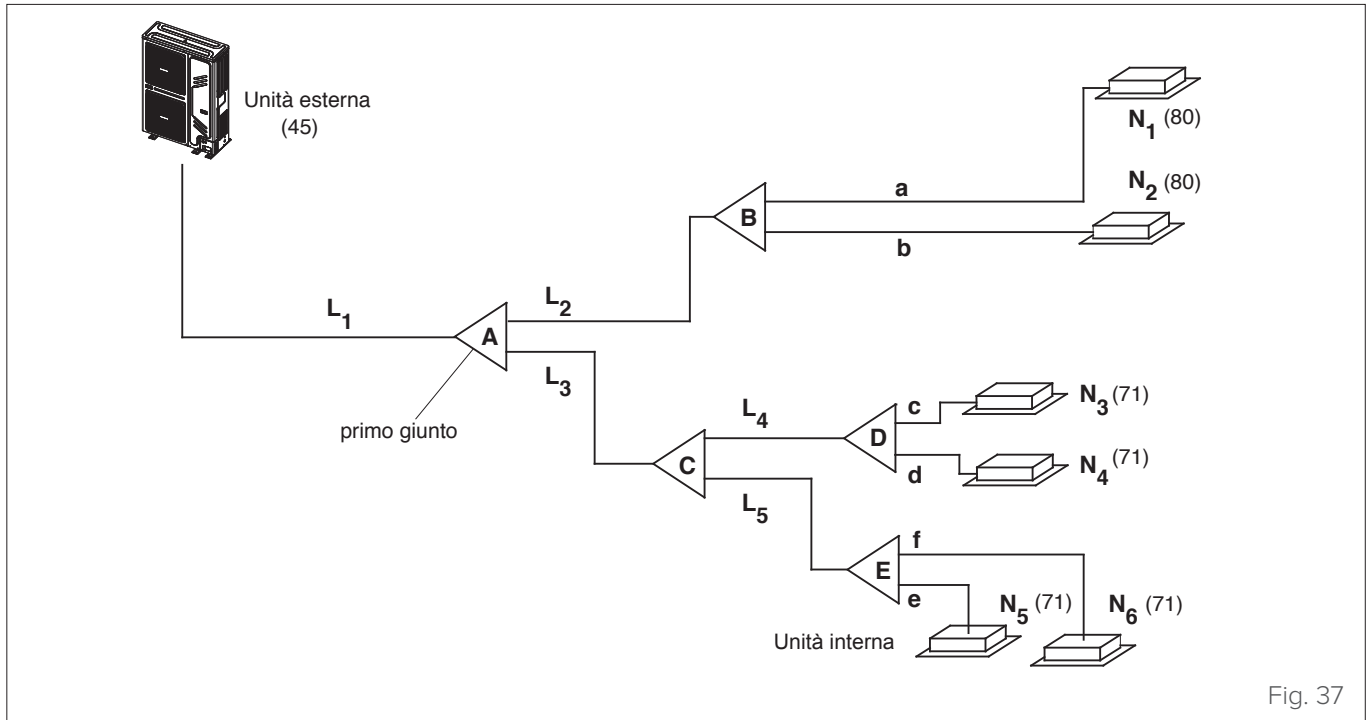

Fig. 37

- ❑ **Select the main internal pipe**
Refer to “Table 4” to select the internal auxiliary pipes (a-f).
- ❑ **Select the main internal pipes and the internal branch joints B to E**
The indoor units (N5 and N6) downstream of the internal branch have a total capacity of $71 \times 2 = 142 \text{ kW}$. See “Table 1”. The main internal pipe L5 is $\text{Ø}15.9 / \text{Ø}9.5$. The internal branch joint E is FQZHN-01C.

The indoor units (N3 and N4) downstream of the internal branch joint D have a total capacity of $71 \times 2 = 142 \text{ kW}$. Refer to “Table 1”. The main internal pipe L4 is $\text{Ø}15.9 / \text{Ø}9.5$. The internal branch joint D is FQZHN-01C.

The indoor units (N3 and N6) downstream of the internal branch joint C have a total capacity of $71 \times 4 = 284 \text{ kW}$. Refer to “Table 1”. The main internal pipe L3 is $\text{Ø}22.2 / \text{Ø}9.5$. The internal branch joint C is FQZHN-02C.

The indoor units (N1 and N2) downstream of the indoor branch joint B have a total capacity of $80 \times 2 = 160 \text{ kW}$. Refer to “Table 1”. The main internal pipe L2 is $\text{Ø}15.9 / \text{Ø}9.5$. The internal branch joint B is FQZHN-01C.

- ❑ **Select the main pipe and the internal branch joint A**
The indoor units (from N1 to N6) downstream of the internal branch have a total capacity of $71 \times 4 + 80 \times 2 = 444 \text{ kW}$. The total sequential length of the system is more than 90 m. The total capacity of the outdoor unit is 45kW. Refer to “Table 2” and “Table 3”. The main pipe L1 is the larger of $\text{Ø}28.6 / \text{Ø}12.7$ and the internal branch joint A is FQZHN-03C.

4.2 Thermal insulation of the pipes

Insulate the refrigerant and gas piping separately with insulating polyethylene foam materials. Incorrect or missing insulation causes condensation and subsequent dripping.

For the connection parts of the indoor unit piping, use heat-insulating materials that stick to the surfaces without leaving gaps.



WARNING

Pipes laid in ceilings are particularly sensitive to condensation.

The thickness of the insulating material must be at least 15/20mm and able to withstand heat of 120°C.

In conditions of high temperatures or humidity it is necessary to increase the thickness of the material.

Size of the pipes	Thickness
Ø12.74 mm	≥15mm
Ø15.9 mm	≥20mm

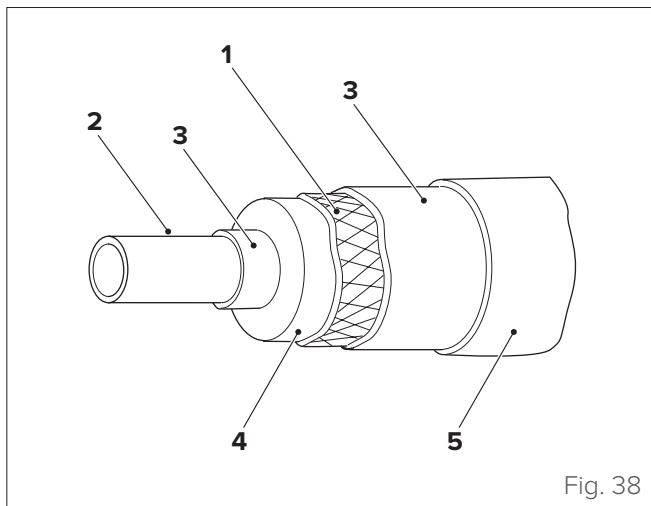

Fig. 38

- 1 Steel wire
- 2 Piping
- 3 Oily bituminous mastic or bitumen
- 4 Type A insulation material
- 5 Type B insulation material

Insulation material	External piping	Internal piping
A	Fibreglass and steel fibre	
	Adhesive, heat-resistant polyethylene foam and adhesive tape	
B	Vinyl tape	Waterproof hemp cloth, zinc plate and oily paint

Do not insulate the electrical cables (6)

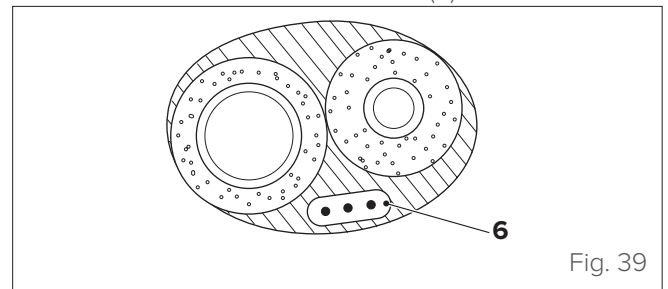

Fig. 39

Make sure that the pipe connections are completely isolated from the indoor unit.

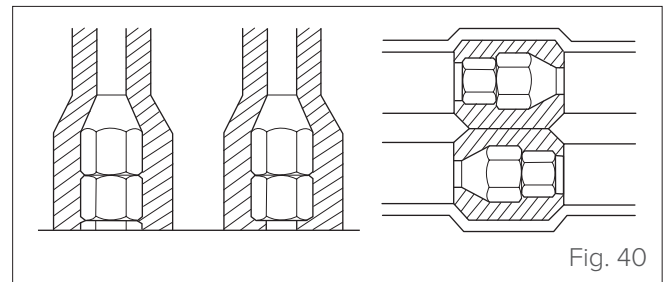

Fig. 40

If the pipe passes through a wall, take the following precautions

Concealed internal wall

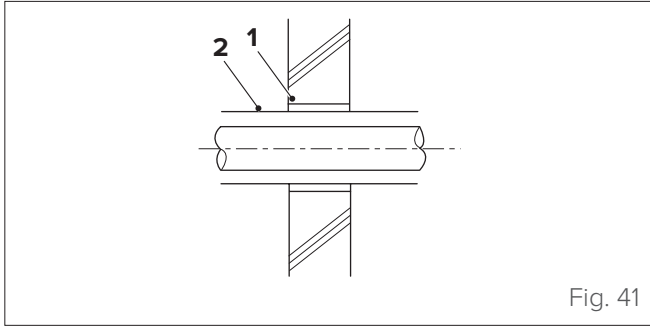

Fig. 41

External wall

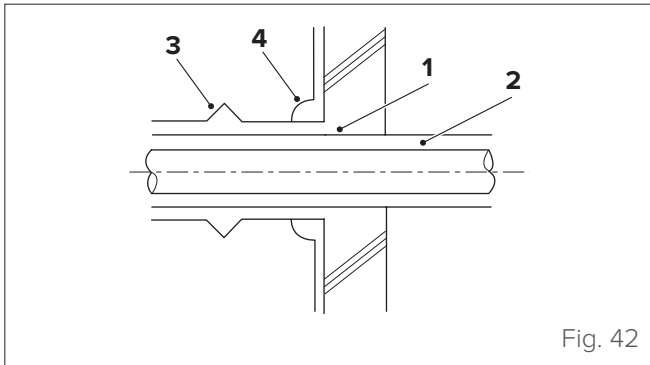

Fig. 42

External wall (exposed)

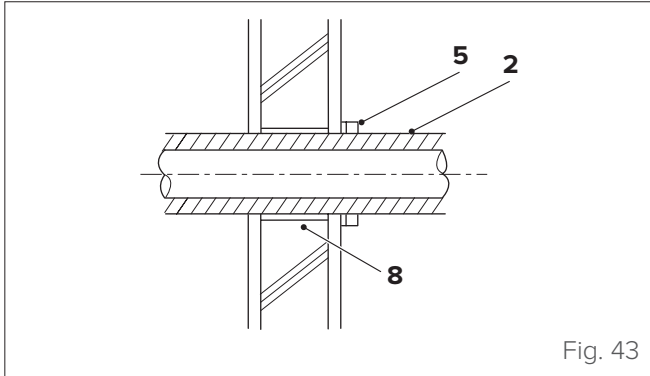

Fig. 43

Waterproof floor

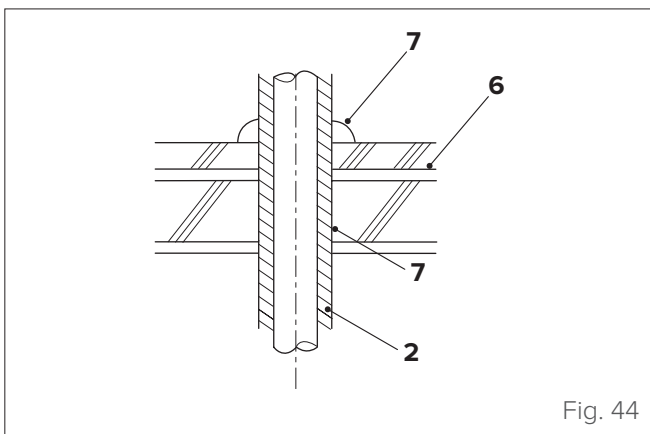

Fig. 44

Roof pipe

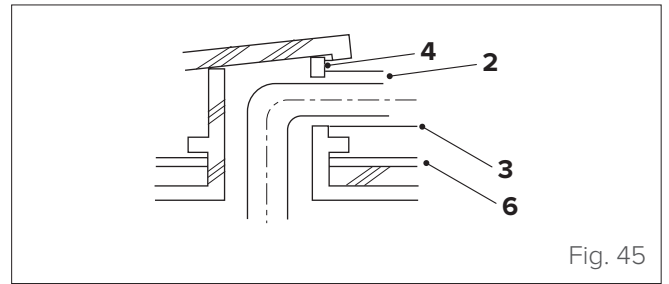

Fig. 45

Protections of parts that penetrate an area with combustible material or a partition wall

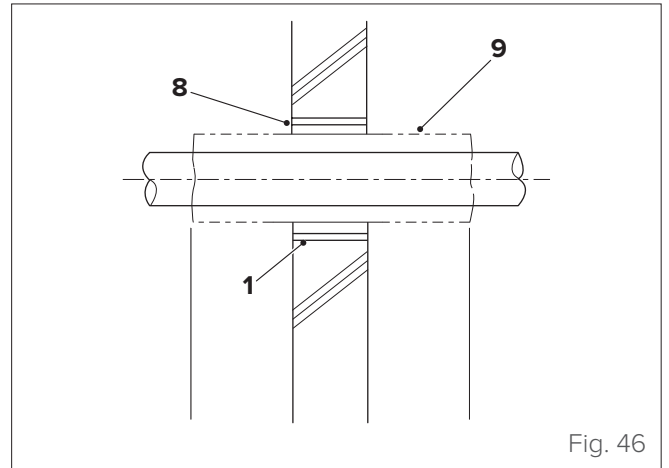

Fig. 46

- 1 Insulating sheath
- 2 Insulating material
- 3 Coating
- 4 Grouting material
- 5 Tape
- 6 Waterproof layer
- 7 Sleeve with a flange
- 8 Grouting with a non-flammable material (e.g. mortar)
- 9 Non-flammable insulating material

5 ELECTRICAL CONNECTIONS

5.1 Preliminary information



ATTENTION ELECTRIC DANGER

- All electrical connections must be done by a licensed electrician according to the provisions of national and local electrical codes.
- All electrical connections must be made according to the wiring diagram on the panels of the indoor and outdoor units.
- If the electrical system has serious safety problems, stop work immediately. Explain the situation to the customer and refuse to install the unit until the safety problem has been resolved.
- The power supply must be between 342 V and 456 V. Insufficient power supply can cause malfunction, electric shock or fire.
- Install overcurrent protection and a main power switch (see “5.2 Power supply line” page 31).
- The power supply line must have a special protection upstream against short circuits and earthing leakage that sections the system with respect to other utilities. The technician must choose an approved differential circuit-breaker or main circuit breaker.
- The air conditioner must be properly grounded.
- All cables and conductors must be connected securely. Loosening a conductor may cause the terminal to overheat, which in turn may result in fire hazards or product malfunction.
- The electrical cables must not touch or rest against the refrigerant pipes, the compressor or any moving parts of the unit.
- The voltage difference between N and T must not exceed 3 V. Higher values indicate suboptimal earthing and can cause failure of the electronics.



ATTENTION ELECTRIC DANGER

Before making electrical connections, turn off the main switch of the system.



CAUTION

- In order to remove the entire electrical panel:
- empty the refrigeration circuit, taking care to recover the refrigerant;
 - desolder the pipe connected to the heat sink which cools the electrical panel
 - disconnect the electrical cables.



WARNING

The electrical system can be divided into two sub-families: the power supply line and the communication bus network. Be careful during the installation process.



WARNING

The insulation of the metal parts and air conditioner must comply with the provisions of the national electrical code.



WARNING

Installation and wiring must be carried out by duly qualified, certified and accredited professionals, in compliance with current regulations.



CAUTION

The refrigerant piping, power cables and communication cables are usually laid in parallel. The power and communication cables must be laid in separate conduits to avoid signal interference. If the power supply is less than 10A, the two conduits must be at least 300 mm apart. In case of a higher power supply rating (between 10 and 50A), the two conduits must be at least 500 mm apart.



ATTENTION ELECTRIC DANGER

- Make sure that the unit is earthed. Keep the earth wire away from gas and water pipes, lightning rods, telephone cables or other earth wires. Incorrect earthing may cause electric shocks.
- Automatic overcurrent and differential switches (earthing switches) must be used in accordance with all the regulations in force



CAUTION

The outdoor units are based on DC inverter technology. Pay attention to the type of power supply: the use of a UPS can damage the unit's power electronics.



CAUTION

Equip each outdoor unit with an electrical disconnecter. The installation of this is mandatory to ensure compliance with the safety standards and to disable each module in case of failure, avoiding system shutdown.



ATTENTION ELECTRIC DANGER

The power line must be connected to the L - N terminals of the internal sections. Be careful not to confuse the terminal blocks for the power supply with those for the bus line.



ATTENTION ELECTRIC DANGER

Separate power sources must be provided for the indoor units and for the outdoor unit.

5.2 Power supply line

The cable must be connected to the terminal block using only crimped cables with eyelet wire terminals

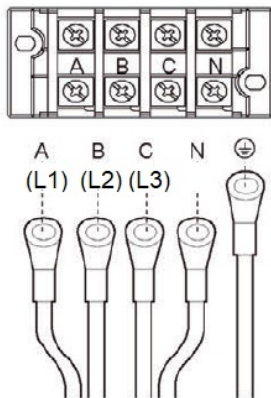

Fig. 47



CAUTION

First connect the power cord and terminals, then secure the cables.

When installing the main power cable, strip the proper amount of insulation according to the method of attachment and positioning of the cable clip.

When tightening the three screws, the twist length must ensure that when 100N of force is applied on the cable, the sagging is less than 2mm. Excessive tightening of the screws can damage the protective cover of the power cable.

The lower part of the clip (1) is fixed on the electrical panel, under the terminals. The upper part (2) is supplied together with the other accessories. Secure the top with the screws (3) supplied.

If the cross-section of the cable (4) is less than 10 mm², fix the cables together

If the cross-section of the cable (4) is greater than 10 mm², fix the cables separately.

When stripping the outer insulation sheath, make sure that the length of the stripping plus the length of the terminal is between 100 and 200 mm

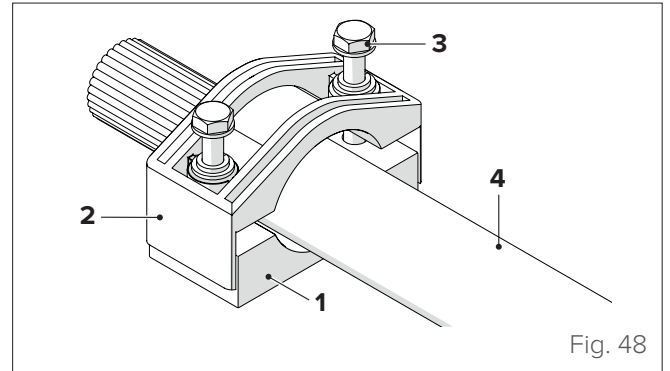

Fig. 48

Outdoor unit connections

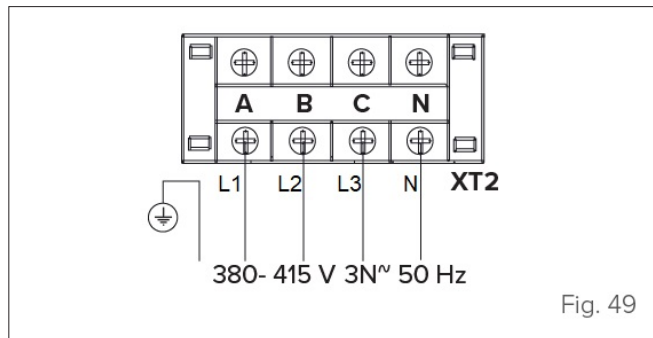

Fig. 49

Power supply specifications

Power supply source		380-415V 3N~ 50Hz	
Model	Capacity (kW)	400T	450T
Power supply	Hz	50	
	Voltage	380-415	
	Min (V)	342	
	Max (V)	456	
	MCA	42.50	52.50
	TOCA	39.84	49.84
	MFA	60	
Compressor	MSC	/	
	RLA	12x2	15.4 x 2
OFM	KW	0.56+0.32	0.56+0.32
	FLA	2.65+3.84	2.65+3.84

- MCA: Max circuit amps (A)
- TOCA: Total overcurrent current amps (A) for each OC set
- MFA: Max fuse amps (A). It is used to select the main overcurrent and differential switches
- MSC: Max starting current (A) of the compressor
- RLA: Rated load amps (A). It is based on the following conditions: indoor temperature 27 °C DB, 19 °C WB, outdoor temperature 35 °C DB.
- OFM: Outdoor fan motor
- FLA: Full load amps (A)
- KW: Rated motor output (kW)

The units are suitable for use with electrical systems where the voltage supplied to the unit terminals is not below or above the given range limits. The maximum allowed voltage variation between phases is 2%
Select the cable size according to the MCA value



CAUTION

Appliances in compliance with IEC 61000-3-12. The fixed wiring must incorporate an omnipolar switch where all active conductors have the minimum contact spacing required by national wiring regulations.



CAUTION

Seal the electrical connections with insulating material to prevent condensate from forming.

Note: Air conditioners can connect to a centralised controller (CCM). Before start-up, connect the cables properly and set the system address and network address of the indoor units.

Indoor unit connections

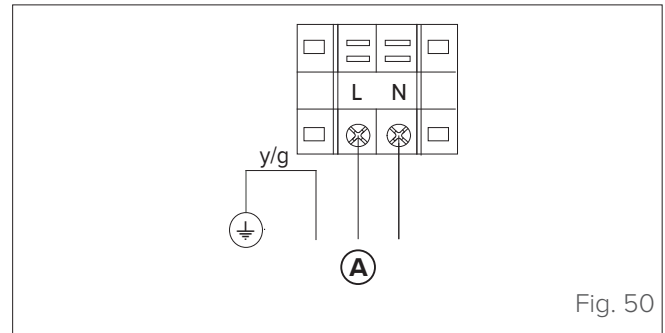

Fig. 50

A Power supply

Power supply specifications

Cooling capacity (kW)		1.8~16
Indoor unit power supply	Voltage and frequency	220-240V~ 50Hz
	Power cable size (mm ²)	3x2.5
Circuit switch (A)		16
Indoor unit/outdoor unit signal cable (mm ²) (weak electrical signal)		3-conductor shielded cable 3X0.75

Note: The diameter and length of the unbroken wires refer to conditions of voltage fluctuations of less than 2%. If the unbroken length of the line exceeds the value indicated, choose the cable diameter according to applicable standards.

How to connect the indoor unit

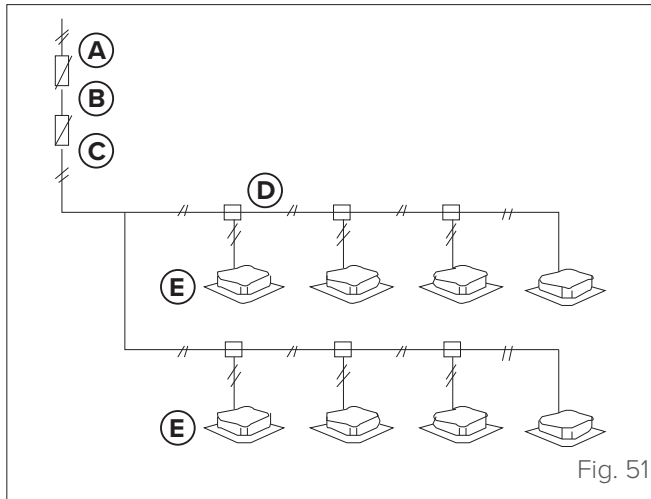

Fig. 51

- A Indoor unit power supply
- B Circuit switch
- C Manual switch
- D Electrical distribution box
- E Indoor unit



CAUTION

The refrigerant pipes, the signal wires connecting the indoor units and the cables connecting the indoor units to the outdoor unit are in the same system. If the power cable is parallel to the signal line, install them in separate distribution ducts and leave enough space. (Reference distance: 300 mm when the current rating of the power cable is less than 10 A, or 500 mm for 50 A).

5.3 Communication bus network

The cables of the bus network (transmission line) must be laid in such a way as to avoid electromagnetic interference.



CAUTION

Do not lay transmission and power cables in the same conduit.

Connect the cables as follows:

- The combinations between internal and external sections must be the same in terms of the refrigeration connections and electrical connections.
- Use the “in and out” type of connection even if the lines work with connection in parallel.
- In case of connection with a controller of a higher level (centraliser), a transmission line is required between each external line.
- Do not connect the power cables to the terminal block of the bus network.
- Do not perform joints but only carry out soldering using a heat shrink sheath. Respect the lengths indicated in the technical manuals.

- Shunt boxes are not allowed.
- Correctly address the components of the system.
- The cable used must be of a type suitable for data transmission with RS 485. If not suitable for such use it can cause interference and difficulties in the transmission of packets.
- The insulation and voltage characteristics of the cable must be in accordance with the electrical regulations in force.
- The insulation of the cable must have flame or fire retarding characteristics, commensurate with the electrical standards of reference for the type of system used.
- The cable must be laid to standard.
- The cable must be laid separately from other cables, especially from power cables or from cables of different voltages.
- The cable must be laid far from cables or devices that can cause electromagnetic interference.
- The RS485 serial line must always be of the “Bus in-out” topology. Different topologies are not allowed (star or ring-type, etc.).
- The serial line must be laid by personnel trained and qualified in data communication networks.

Connecting the shield

- For the bus network, use 0.75 mm³ 3-pole shielded cables. Using other types of cables may result in interference or malfunctions.
- The shield of the bus cable used for serial communication must be connected to an earth free from interference.
- The shield must be earthed at one point only.
- The continuity of the shield must be ensured the entire length of the bus cable.



WARNING

These requirements are generally valid. In some areas characterised by the presence of particular types of EMI coupling, a different type of connection of the shield may be required.



CAUTION

Make sure that the metal braiding of the cables does not touch any live points. Use dedicated wire terminals.

Outdoor unit connections

20 - 28 kW

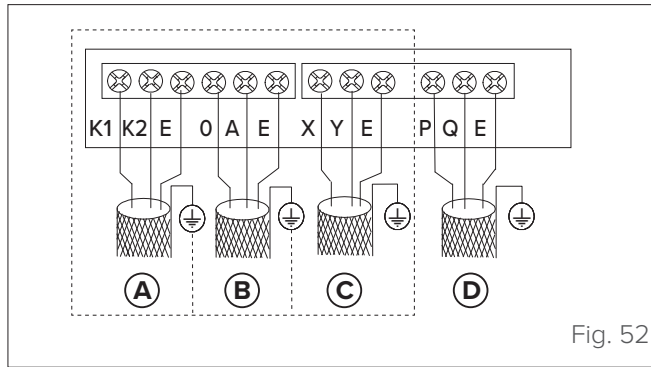

Fig. 52

- A Outdoor unit central monitor (optional)
- B Digital electric meter (optional)
- C Indoor unit central monitor (optional)
- D Indoor unit central monitor

A wrong connection can cause malfunctions. Electrical connections: seal the electrical connections with insulating material to prevent condensate from forming.



CAUTION

Do not earth communication cables P and Q.

The shielding networks of the communication cables must be connected together and earthed. For earthing, join the adjacent metal casing with terminals P, Q, E of the electrical panel of the outdoor unit.

Terminals	Connection
K1 K2 E	Centralised monitoring of the outdoor unit (*)
O A E	Digital energy meter
X Y E	Centralised control unit of the indoor unit (and of the outdoor unit if K1 K2 E is not present)
P Q E	Connection between indoor units and the main outdoor unit

(*) if not present, the monitoring function of the outdoor unit is integrated in the terminal block X Y E.

Indoor unit connections

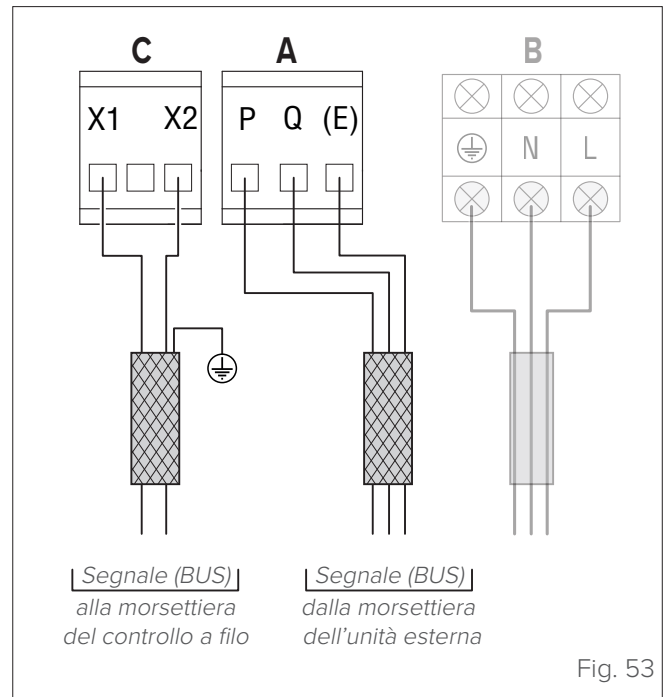

Fig. 53

- A Communication bus
- B Power supply
- C Wired controller

The dedicated function of the wired controller is shown in the diagram with a dotted line, indicating that users can only buy it when it is required. Use a 3-conductor shielded cable and connect the shielded layer to earth.

- The signal cable is 3-conductor, polarised. Use a 3-conductor shielded cable to avoid interference. Put the closed end of the shielded cable on the ground and open (insulate) the end. **The shielding must be earthed at one point free of interference.**
- The control line between the outdoor unit and the indoor unit is BUS type. The addresses are configured on site during installation.



CAUTION

Earth only at one point in the system since multiple points can generate transmission noise.



CAUTION

Within a group, connect only indoor units of the same type (wall, ducted, recessed).

Electrical connections

Connect the various indoor and outdoor units as shown in the diagram below.

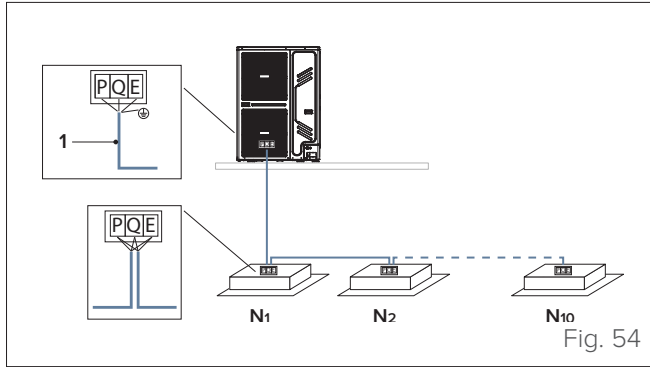

1 Bus between outdoor unit and indoor units

Close the chain between P and Q in the last indoor unit with the 120Ω resistor supplied with the outdoor unit. Do not return the bus to the outdoor unit.

5.4 Wiring method

Communication with indoor unit: The communication line P, Q, E must be connected in a chain leading from the outdoor unit to each indoor unit and up to the last indoor unit, connecting a 120Ω heater between terminals P and Q. The correct and incorrect methods of connection are shown below:

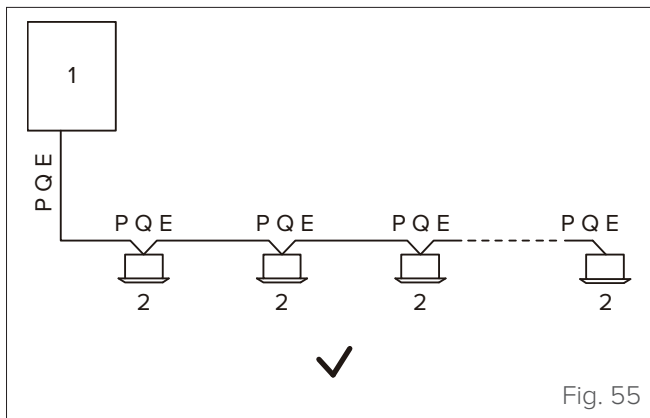

- 1 Outdoor unit
- 2 Indoor unit

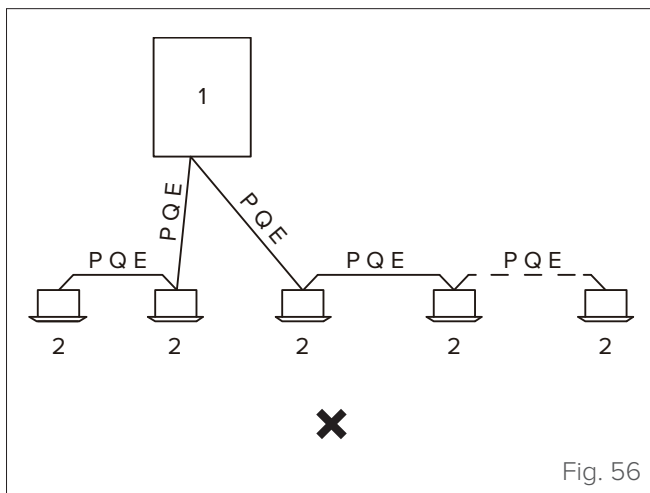

- 1 Outdoor unit
- 2 Indoor unit

Do not connect two chains from a single outdoor unit.

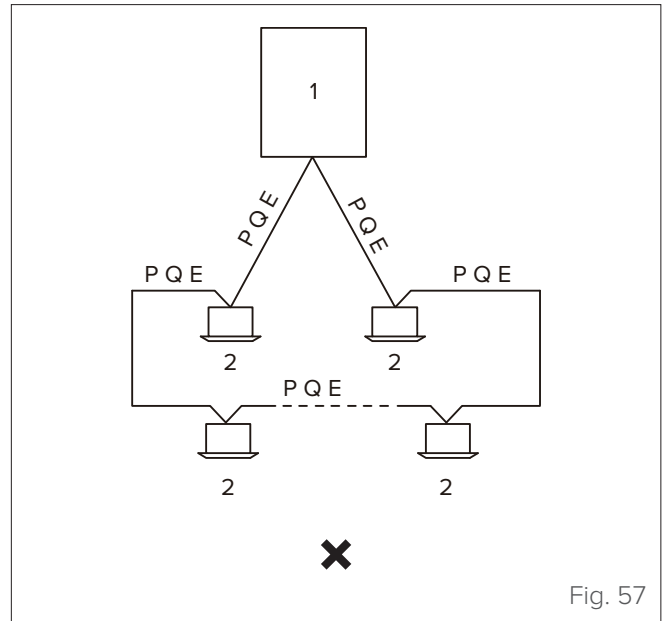

- 1 Outdoor unit
- 2 Indoor unit

After the last indoor unit, the communication cables must not be led back to the outdoor unit as to do so would form a closed circuit.



WARNING

The cross-section of each core of the communication cabling must not be less than 0.75 mm^2 and the length must not exceed 1200 m . A communication error can occur when the communication cabling exceeds these limitations.

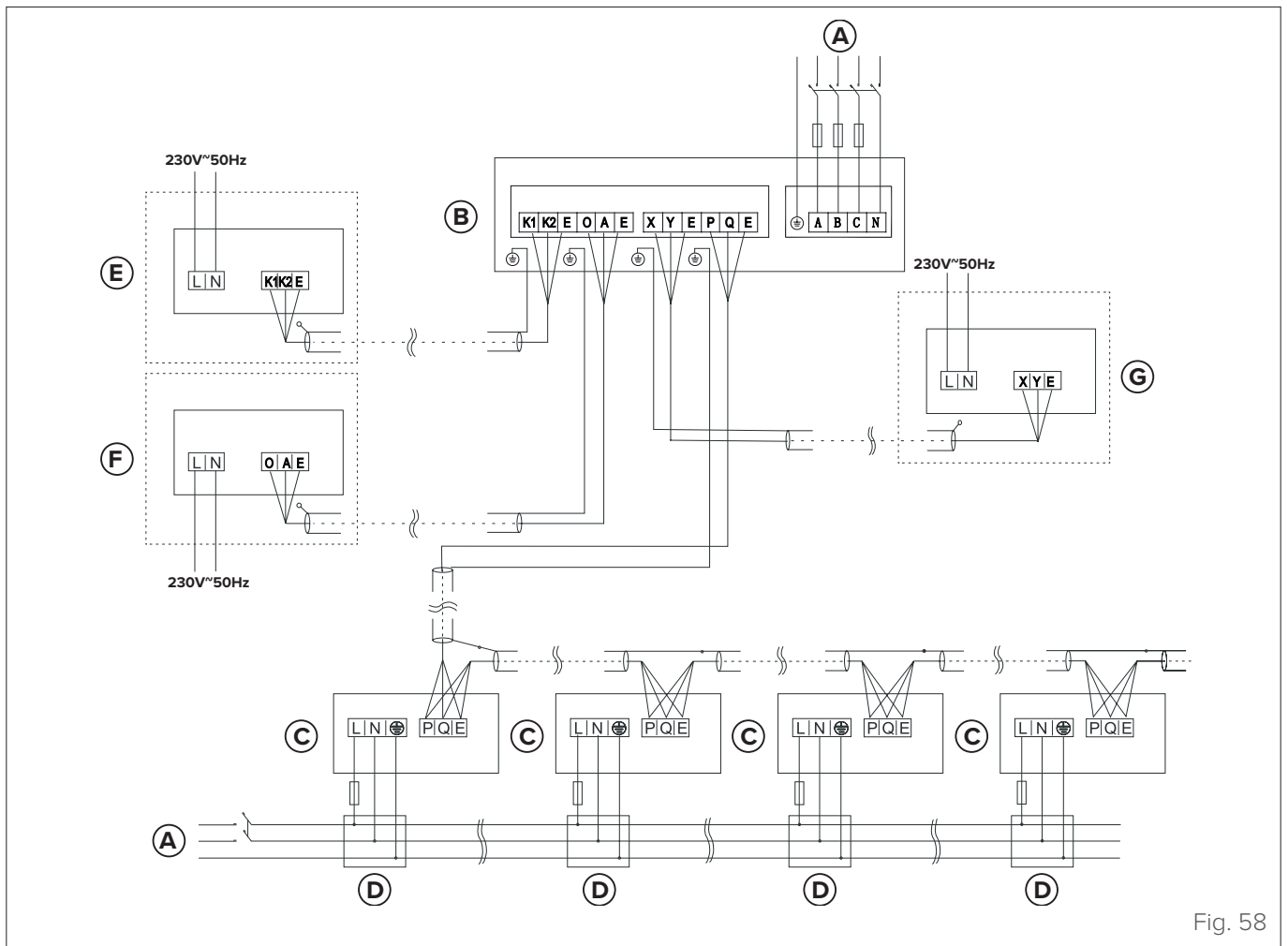

Fig. 58

- A** Outdoor power supply
- B** Outdoor unit
- C** Indoor unit
- D** Shunt box
- E** Outdoor unit monitor
- F** Energy meter
- G** Centralised control/gateway



CAUTION

It is possible to start with only one bus from the outdoor unit.



CAUTION

Earth at one point free of interference.

Controller connection

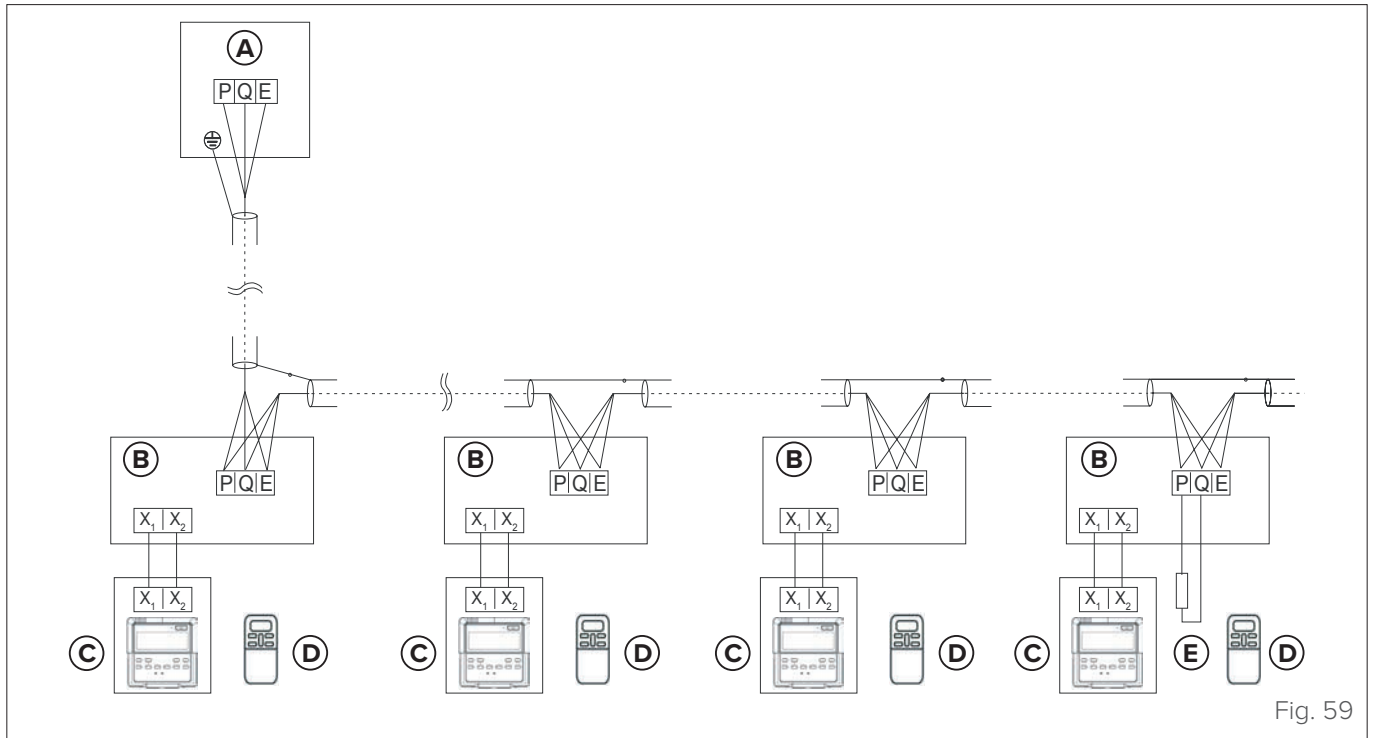

Fig. 59

- A** Outdoor unit
- B** Indoor unit
- C** Wired controller
- D** Remote controller
- E** Resistor - Add a resistor only at the P / Q end of the last indoor unit.

CAUTION
Select the power supply source for the indoor unit and the outdoor unit respectively.

CAUTION
The power supply must come from a branch circuit complying with the specifications, with leakage protection and a manual switch.

CAUTION
For outdoor unit models with different power supply types, refer to the unit's data plate. (Connect all power supply lines of indoor units in the same system to the same branch circuit.)

CAUTION
Lay the electrical connections between the indoor and outdoor units together with the refrigerant lines.

CAUTION
Use 3-wire shielded cables for the signal lines of the indoor and outdoor units.

6 STARTING UP THE SYSTEM

6.1 Flushing the pipes

The refrigerant piping must be flushed with nitrogen to remove dust, moisture and other particles that could cause the compressor to malfunction if not eliminated before the system is put into operation.

Flushing should be carried out after completing connection of the piping, with the exception of final connections to indoor units.



WARNING

Flushing must be performed before connecting to indoor units.



CAUTION

Use only nitrogen for flushing. Do not use carbon dioxide since it can create condensation in the pipes. Oxygen, refrigerant, flammable gases and toxic gases must not be used for flushing. The use of such gases can cause fire or explosion.

The flushing procedure is as follows:

- 1 Cover the inlets and outlets for the indoor units to prevent dirt from being sucked inside during flushing of the pipes.
- 2 Attach a pressure reducing valve to the cylinder of nitrogen.
- 3 Connect the outlet of the pressure reducing valve to the inlet on the liquid (or gas) side of the outdoor unit.
- 4 Use blanking plugs to block all openings on the liquid (gas) side except for the opening on the indoor unit (N₆) which is farthest from the outdoor unit.
- 5 Begin to open the valve of the cylinder of nitrogen before gradually bringing the pressure to 0.5bar.
- 6 Allow the nitrogen to flow to the opening of the indoor unit (N₆).
- 7 Clean the opening with a cloth until no more dirt or moisture comes out. Check with a clean cloth that the opening is clean.
- 8 Seal the opening

Repeat steps 7 and 8 for all the outlets of the indoor units, from the furthest to the closest to the outdoor unit.

- 9 Seal all the openings.

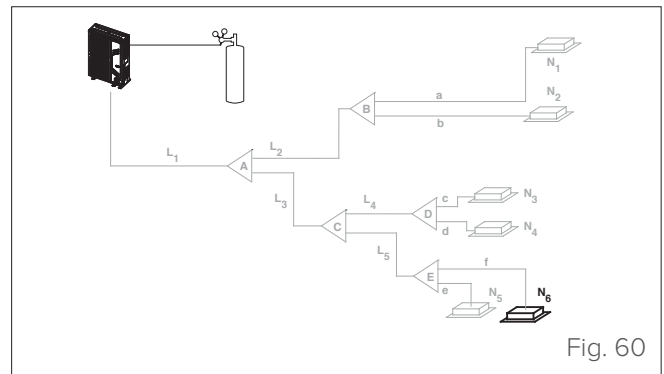

Fig. 60

6.2 Gas leak test

A leak test must be carried out before the system is put into operation, in order to avoid failures caused by the leaking of refrigerant.



CAUTION

Use dry nitrogen only. Do not use oxygen, flammable gases and toxic gases. The use of such gases can cause fire or explosion.



CAUTION

Make sure that all the stop valves of the outdoor unit are closed tightly.

- Connect the outdoor unit and indoor units and create a vacuum in the piping at -0.1Mpa.

A vacuum pump with a minimum capacity of 80-120 litres/minute is required for vacuum operations.

If the required value is not reached, it is recommended to carry out further drying using the triple vacuum procedure.

- Fill the internal piping with nitrogen at 0.3Mpa via the needle valve of the liquid stop valves (3). Leave to act for at least 3 minutes.

Do not open the liquid (1) or gas (2) stop valves. Observe the pressure gauge to check for significant leaks. If there is such a leak, the hand of the pressure gauge will go down rapidly.

- Fill the system with nitrogen at 1.5Mpa and leave to act for at least 3 minutes.

Observe the pressure gauge to check for small leaks. If there is such a leak, the hand of the pressure gauge will go down rapidly.

- Fill the system with nitrogen at 4.0Mpa and leave to act for at least 24 hours.
- Write down the initial room temperature (Ti).

A change in the room temperature of 1°C corresponds to a change in the pressure of the nitrogen charged in the line of 0.01MPa (0.1bar). Use this correction factor when comparing the final room temperature (Tf) with the initial one (Ti).

Example:

Initial room temperature (Ti) after charging with N₂: 26°C
 Nitrogen pressure (Pi) in the system at 26°C: 4.0 MPa (40bar)

Final room temperature (Tf) after 24 hours: 18°C

Nitrogen pressure (expected) at final room temperature (Tf) after 24 hours:

$$= 40 \text{ bar} + (18^\circ\text{C} - 26^\circ\text{C}) \times 0.1 \text{ bar}/^\circ\text{C}$$

$$= 40 \text{ bar} - 0.6 \text{ bar}$$

$$P_f = 39.4 \text{ bar}$$

If the actual final pressure (Pf) is evidently lower than the expected final pressure (Pf) (< 39.4 bar), there is a leak that needs to be found.

- Perform vacuum drying. See paragraph [“6.3 Vacuum operation”](#) page 39

If drying cannot be carried out immediately, reduce the pressure to 0.5-0.8MPa until drying is possible.

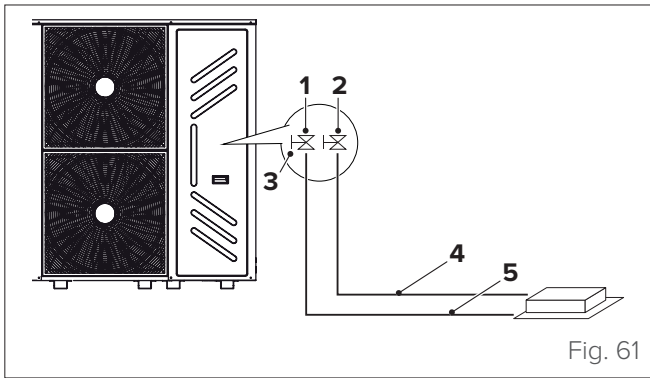

In order to detect nitrogen leaks, proceed as follows:

- it is possible to hear a noise when there are significant leaks;
- put your hands on the joints to feel for gas leaks;
- apply soapy water over the joints made. If bubbles form, there are small leaks.
- check all the joints with a leak detector.

6.3 Vacuum operation

Perform drying to remove moisture and non-condensable gases from the system. The elimination of moisture prevents the formation of ice and the oxidation of copper pipes or other internal components.

The presence of ice particles in the system could cause malfunctions.

Oxidised copper particles can cause damage to the compressor.

Non-condensable gases present in the system could cause pressure fluctuations and lead to poor performance of the heat exchanger.

The combination of a vacuum operation and a gas leak test facilitates the detection of leaks.



CAUTION

Before vacuum drying, make sure that all the stop valves of the outdoor unit are closed.



CAUTION

Use only one-way valves. Once the procedure is complete and the pump stops, the low pressure can draw the lubricant from the pump into the system. The same situation arises if the pump suddenly stops during the procedure.

Mixing of the pump lubricant with the compressor oil can cause the compressor to malfunction.

To perform drying, a vacuum pump is used to lower the pressure in the pipes until all the moisture present evaporates.

It is necessary to use a vacuum pump capable of maintaining a pressure equal to or less than -756 mmHg (recommended vacuum level: <750mTorr) below atmospheric pressure. At -755 mmHg below atmospheric pressure, water reaches its boiling point at 0 °C.

We recommend using a vacuum pump with a discharge rate greater than 4 litres/s and an accuracy level of 0.02 mmHg

To carry out the vacuum operation, proceed as follows:

- Connect a three-way pressure gauge (1) to the gas pipe stop valve (2) of the main unit via the low pressure pipe (B) and to the liquid pipe stop valve (3) via the high pressure pipe (A) and to the vacuum pump (4) via the vacuum refrigerant pipe (C).

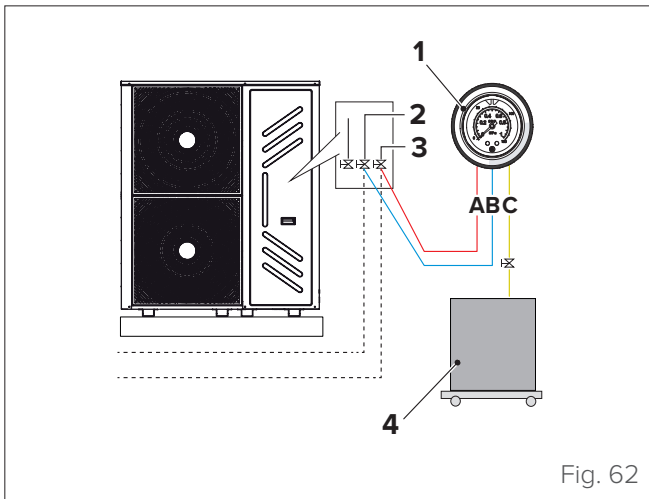

Fig. 62

- Activate the vacuum pump. Open the valves of the pressure gauge to start creating a vacuum in the system.
- After 30 minutes close the valves of the pressure gauge.
- If within 5/10 minutes the pressure gauge returns to zero, there are leaks in the system. Proceed with repair.
- Open the pressure gauge valves again and continue drying for at least two hours and in any case until a pressure difference of 0.1 Mpa is exceeded. Once this pressure is reached, continue for another two hours.
- Close the pressure gauge valves.
- Stop the vacuum pump.
- If the pressure in the piping has not increased after one hour, the procedure is over. If the pressure has increased, there are leaks in the system.

When done, it is possible to keep the high and low pressure hoses connected to the pressure gauge and to the stop valves of the master unit for the purpose of charging with refrigerant.

6.4 Charging with refrigerant



CAUTION

Charge the refrigerant only after having done “6.2 Gas leak test” page 38 and “6.3 Vacuum operation” page 39 .



CAUTION

Do not charge more refrigerant than necessary because to do so can seriously compromise the correct functioning of the refrigeration circuit.



CAUTION

Use only R410A refrigerant. Charging with other substances may cause an explosion and fire.



CAUTION

When charging the refrigerant, wear suitable PPE such as gloves and protective goggles.



CAUTION

Open the refrigerant containers slowly.



WARNING

Use only instruments and appliances designed for use with R410A refrigerant.



WARNING

The refrigerant must be treated in compliance with the regulations in force.

Starting up the system

The outdoor unit is supplied with a basic refrigerant charge.

Model (kW)	Factory pre-charge (kg)	CO ₂ equivalent (tons)
40	9	18.79
45	12	25.06

An additional charge is required based on the length and diameter of the refrigerant line connecting the outdoor unit to the indoor units.

If the outdoor unit is connected to only one indoor unit:

Diameter of pipes (mm)	Additional charge per metre of length (kg/m)
6.4	0.022
9.5	0.057
12.7	0.110
15.9	0.170



WARNING

For each branch-joint (Y or branches) in the refrigerant line, 0.5 m must be added to the total length of the pipes.

Once the value has been obtained, proceed as follows:

- Place a tank of R410A refrigerant on a scale. In this way the refrigerant will be charged in the liquid state.



WARNING

The correct composition is in the liquid state, not gaseous. For this reason it is advisable to stop charging when approximately 5% by weight of the initial content remains in the cylinder. Otherwise there is a risk of transferring the refrigerant in its gaseous state.

- Connect the 3-way pressure gauge (1) to the gas pipe stop valve (2) of the master unit via the low pressure pipe (B) and to the liquid pipe stop valve (3) via the high pressure pipe (A) and to the refrigerant tank (4) via the vacuum refrigerant pipe (C).

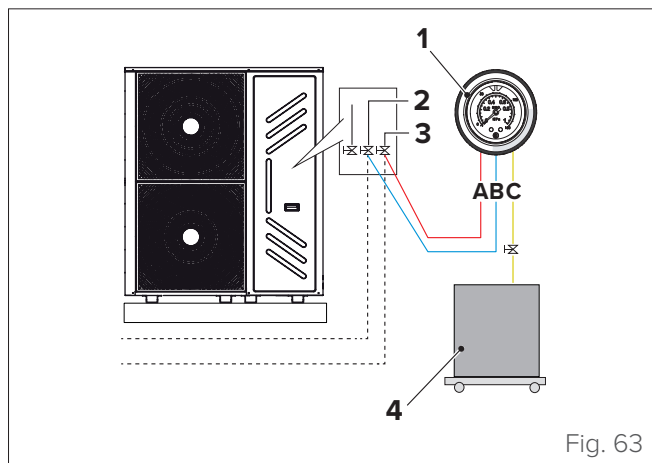

Fig. 63

- Before opening the service valve on the R410A cylinder, it is recommended to put the hoses

under vacuum, using the special pump, to avoid the introduction of air and other non-condensable products into the refrigeration circuit.



CAUTION

Danger of freezing. Slowly open the tank and use PPE.

- Open the three valves on the pressure gauge to start charging the refrigerant.
- Close the valves once the desired quantity is reached.

In case the refrigerant tank is insufficient for a complete charge, close the three valves on the pressure gauge, start the outdoor unit in cooling mode, then open (C) and (B).

Connect the yellow pipe to a new tank and resume charging until the desired charge is complete. Close the valve (C) and (B).



CAUTION

Before starting the system, make sure to complete all the checks/controls required before initial start-up (see paragraph “8.1 Start-up preparations” page 50) and make sure to open all the stop valves. Starting the system with the stop valves closed can cause damage to the compressor.

FULL REFRIGERANT CHARGE

If a full charge of refrigerant is required (e.g. after moving/replacing the unit or after a leak), the total refrigerant charge will be the sum of the factory refrigerant pre-charge + the additional charge.



IT IS PROHIBITED TO
mix different types of refrigerant

R410A refrigerant is chemically stable, of low toxicity and non-flammable, and belongs to the family of HFCs. R410A is a mixture of R32 refrigerant (50%) and R125 (50%), with properties very close to that of an azeotropic mixture (it behaves almost as a pure gas) with a negligible glide temperature (about 0.2 Celsius degrees with the split system under normal operating conditions). It is also neither explosive nor inflammable, it has low toxicity (safety class A1, like R22) and it is not corrosive under normal conditions. The permitted limit of exposure is the same as that of R407C and R22.

R410A is a “nearly azeotropic” mixture of two refrigerant gases (R32 and R125). The “nearly azeotropic” condition refers to a state in which the dew point curve and the boiling point curve (gas/liquid equilibrium curves at constant pressure) almost overlap. With this chemical characteristic, the refrigerant mixture undergoes negligible changes in composition when a change of state occurs (evaporation or condensation). Consequently, even when a loss of refrigerant in the gas phase occurs, the composition of the refrigerant undergoes a negligible change.

Therefore, in the event of small leaks of refrigerant, R410A can be treated in the same way as pure refrigerant R22, and can be topped up in small quantities. On the other hand, in case of replacement of a component of the refrigeration circuit, or a more serious leak, the normal procedures must be observed, recovering all the refrigerant fluid. After eliminating the leak or carrying out the repair, the system must be completely evacuated to eliminate the air and then recharged with virgin gas. The recovered gas cannot be reused.

MAXIMUM LEVEL OF CONCENTRATION

The calculation of the maximum concentration of refrigerant is directly related to the space in which the refrigerant can leak, and to the quantity of refrigerant charge.

The unit of measurement of concentration is kg/m³ (weight of the gaseous refrigerant that has a volume of 1 m³ in the space).

The maximum permitted level of concentration must comply with the applicable regulations and local standards. In accordance with the European standards that apply, the maximum permitted concentration of R410 in the space occupied by human beings is limited to 0.44 kg/m³.

PRECAUTIONS FOR REFRIGERANT LEAKS

This air conditioner uses a harmless and non-flammable refrigerant. The room in which the appliance is installed must be large enough to prevent a refrigerant leak from reaching a critical concentration. It is therefore important to take some essential precautions.

Critical concentration: maximum concentration at which freon is harmless to humans.

Critical concentration of refrigerant: 0.44[kg/m³] for R410A.

Check the critical concentration with the procedure below and take the necessary measures.

- Calculate the sum of the charge volumes (**A[kg]**)
Total refrigerant volume of 10HP=refrigerant volume pre-charged in the factory + subsequent additions.
- Calculate the room cubage (**B[m³]**) (minimum cubage).
- Calculate the refrigerant concentration (**A/B**) ≤ **Critical concentration**.

Countermeasure in case of excessive concentration:

- Install a mechanical fan to lower the refrigerant concentration below the critical value (ventilate regularly).
- If the room cannot be ventilated regularly, install a leak detection device connected to the mechanical fan.

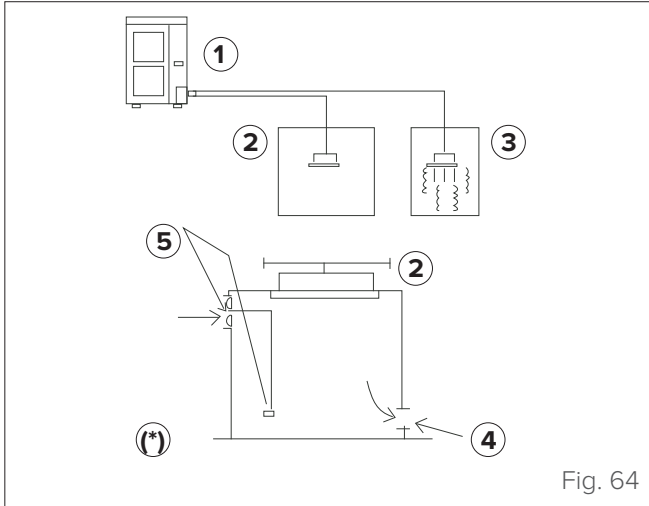

Fig. 64

- 1 Outdoor unit
 - 2 Indoor unit
 - 3 Room with a refrigerant leak (maximum build-up of refrigerant)
 - 4 Ventilation opening
 - 5 Leak detection alarm connected to the mechanical fan
- (*) The leak signalling siren should be installed in a place that is easy to reach from the refrigerant



WARNING

Press the “forced cooling” button to carry out the refrigerant recirculation procedure. Keep the minimum pressure above 0.2 MPa to avoid possible damage to the compressor.

IMPORTANT INFORMATION ON THE REFRIGERANT USED

This product contains fluorinated greenhouse gases regulated by the Kyoto protocol. Do not release gases into the atmosphere.

Type of refrigerant: R410A; GWP value: 2088;
GWP = global warming potential

Outdoor unit cooling capacity kW	Factory charge	
	Refrigerant/kg	Tons of equivalent CO2
40	9	18.79
45	12	25.06

Frequency of refrigerant leakage checks:

- For appliances containing fluorinated greenhouse gases of 5 tons or more of equivalent CO₂ but less than 50 tons of equivalent CO₂, at least every 12 months or, where a leak detection system is installed, at least every 24 months.
- For appliances containing fluorinated greenhouse gases of 50 tons or more of equivalent CO₂ but less than 500 tons of equivalent CO₂, at least every six months or, where a leak detection system is installed, at least every 12 months.
- For appliances containing fluorinated greenhouse gases of 500 tons or more of equivalent CO₂, at least every three months or, where a leak detection system is installed, at least every six months.
- Appliances containing fluorinated greenhouse gases that are not hermetically sealed may only be sold to end users when it is proven that the installation will be carried out by a certified professional.
- Installation, operation and maintenance should only be carried out by certified professionals.

7 SPECIAL FUNCTIONS

7.1 Configuration of the dip-switches



CAUTION

Disconnect the power supply before configuring the dip switch

The dip-switches can be configured in various ways at the switches on the main control board of the outdoor unit

Key	
	Dip-switch ON (1)
	Dip-switch OFF (0)

Switch	Setting	Description
ENC1		Reserved

Switch	Setting	Description
ENC2		Outdoor unit capacity: 0 to 2 0 - 12HP (35 kW) / 14H P (40kW) 1 - 216HP (45 kW) 2 - 20HP (50 kW)

Switch	Setting	Description
ENC3 S12		(S12=00) Indoor units between 0 and 15 0/9 indicates units 0 to 9 A/F indicates units 10 to 15
		(S12=01) Indoor units between 16 and 31 0/9 indicates units 16 to 25 A/F indicates units 26 to 31
		(S12=10) Indoor units between 32 and 47 0/9 indicates units 32 to 41 A/F indicates units 42 to 47
		(S12=11) Indoor units between 48 and 63 0/9 indicates units 48 to 57 A/F indicates units 58 to 63

Switch	Setting	Description
ENC4		Network address selector of the outdoor unit; a valid 0-F code represents 0-15

S1 - Only for 45kW / 40kW units



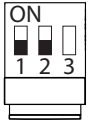
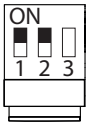
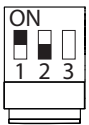
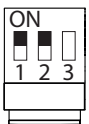

Switch	Setting	Description
S1		(00) Switch-on takes 5 minutes
		(11) Switch-on takes 12 minutes (factory setting)

S2 - Only for 45kW / 40kW units:

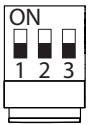
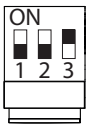
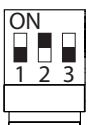
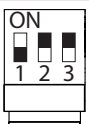
Switch	Setting	Description
S2		(000) Silent operation at night 6h/10h (factory setting)
		(001) Silent operation at night 6h/12h
		(010) Silent operation at night 8h/10h
		(011) Silent operation at night 8h/12h

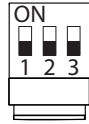
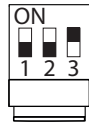
Switch	Setting	Description
S3		(00) Silent night mode (factory setting)
		(01) Silent mode
		(10) Super silent mode
		(11) No silent mode

Switch	Setting	Description
S4		(000) No static pressure mode (factory setting)
		(001) Low static pressure mode (to be customised)
		(010) Medium static pressure mode (to be customised)
		(011) High static pressure mode (to be customised)

Switch	Setting	Description
S5		(000) Heating mode priority (factory setting)
		(001) Cooling mode priority
		Address 63 of the indoor unit defines the priority. If there is no IDU addressed #63, priority is defined by the largest number of IDUs operating in heating or cooling mode (VOTE)
		(011) Heating mode only
		(100) Cooling mode only

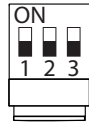
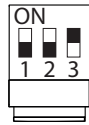
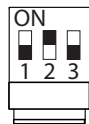
Switch	Setting	Description
S6		(000) Automatic addressing mode
		(001) Manual addressing mode (factory setting)
		(010) Deletes the address of the indoor unit (only available for automatic search of a new indoor unit)

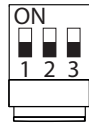
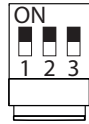
Switch	Setting	Description
S7		(000) Indoor unit number setting (function enabled) (factory setting)
		(111) Indoor unit number setting (function disabled)

S8 - Only for 33.5kW / 40kW units:

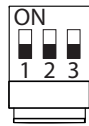
Switch	Setting	Description
S8		Reserved

S8 - Only for 45kW units:

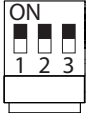
Switch	Setting	Description
S8		Factory settings

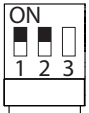
Switch	Setting	Description
S10		Reserved

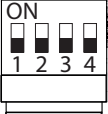
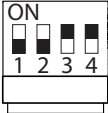
Switch	Setting	Description
S11		Settings for 6-10HP outdoor unit
		Settings for 12-18HP outdoor unit

Forced Cooling Operation

The main control board of the outdoor unit has a forced cooling button SW1 (1).

Pressing this button sends a forced cooling signal to all indoor units.

Forced cooling is applied to all indoor units.

The outdoor units operate at the fixed frequency shown in the table below, and the fans of the indoor units operate at high speed.

Pressing the button again deactivates the forced cooling function.

Operating frequencies in forced cooling mode

Mode	Forced cooling frequency (Hz)
33.5kW / 40kW	62
45kW	48

Control of operating values

The main control panel of the outdoor unit contains an operating value control button (2). By pressing this button, the digital display of the main control panel will show the operating parameters in a cyclical manner (one parameter each time the button is pressed) in the order indicated further on.

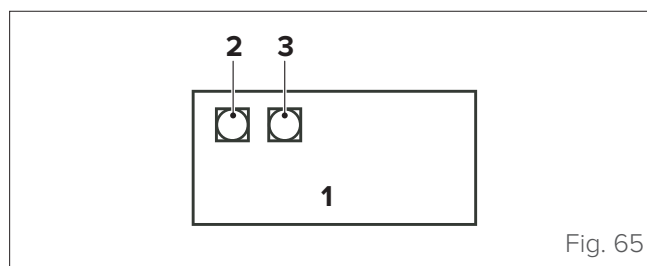

Fig. 65

- 1 Main board (outdoor unit)
- 2 SW1 Forced cooling button
- 3 SW2 Button to control the operating values

7.1.1 System control mode

Display	Description	Notes
0.--	Outdoor unit address	0
1.--	Outdoor unit capacity setting	8, 10, 12, 14, 16, 18
2.--	Number of outdoor units	Reserved
3.--	Number of indoor units setting	Available for the main unit
4.--	Total capacity of the outdoor units	Reserved
5.--	Total capacity required of the indoor units	Available for the main unit
6.--	Revised total capacity requirements of the outdoor unit	Current value = value displayed
7.--	Operating mode	0, 2, 3, 4 (*)
8.--	Actual operating capacity of this outdoor unit	Capacity requirements
9.--	Fan A speed	0, 1,, 9, 10 (**)
10.--	Fan B speed	0, 1,, 9, 10 (**)
11.--	Average temperature T2B / T2	Current value = value displayed
12.--	Temperature of pipe T3 / T3 A	Current value = value displayed
13.--	Room temperature T4	Current value = value displayed
14.--	Inverter compressor A supply temperature	Current value = value displayed
15.--	Inverter compressor B supply temperature	Current value = value displayed
16.--	Radiator temperature	-
17.--	Inverter compressor A current	Current value = value displayed
18.--	Inverter compressor B current	Current value = value displayed
19.--	EXV A opening degree	Pulsed value = value displayed (***)
20.--	EXV B opening degree	Pulsed value = value displayed (***)
21.--	High pressure	Reserved
22.--	T3B	Reserved for 33.5kW / 40kW units
23.--	Number of indoor units	Communication with indoor units
24.--	Number of indoor units in operation	Current value = value displayed
25.--	Mode priority	0, 1, 2, 3, 4 (****)
26.--	Night noise control mode	0, 1, 2, 3 (****)
27.--	Static pressure mode	Reserved
28.--	DC voltage A	Current value = value displayed x 10
29.--	DC voltage B	Current value = value displayed x 10
30.--	Program version	-
31.--	Last error or protection code	In the absence of errors or protection codes, the code 8.8 is displayed.
32.--	--	End of check

When the outdoor unit is in standby, the display shows the number of indoor units that can communicate with the outdoor unit and the operating frequency of the inverter compressor when capacity is required.

(*) Operating mode: 0 - closed; 2 - cooling mode; 3 - heating mode; 4 - forced cooling mode.

(**) Fan speed: 0 - closed; 1 ~ 10: sequential speed increase, 10 is the maximum speed.

(***) EXV opening angle: Number of pulses = displayed value * 8;

(****) Priority mode: 0 - Heating priority; 1 - Cooling priority; 2 - Priority mode open; 3 - Response to heating mode only; 4 - Response to cooling mode only.

(*****) Night Noise Control Mode: 0 - Night noise control mode; 1 - Silent mode; 2 - Reserved; 3 - No priority.

7.1.2 Error codes

Code	Description	Notes
E0	Communication error of the outdoor unit	
E1	Phase protection	
E2	Communication error with the indoor unit	After the first start-up, the communication is interrupted twice within 20 minutes
E4	Outdoor temperature sensor error	
E5	Voltage protection	
E7	Discharge sensor error	If the outlet temperature is below 15 °C for 5 minutes after 10 minutes of operation, code E7 is shown on the display; as soon as the temperature of the GAS exceeds the value of 25 °C the unit resumes normal operation
E8	Error in the address of the outdoor unit	
xE9	Incorrect drive model	The X represents the system: 1 is system A, 2 is system B
EA	Protection with a 5-minute delay in zone A (heating fan)	
xH0	Communication error between IR341 and main chip	The X represents the system: 1 is system A, 2 is system B
H1	Communication error between 0537 and main chip	
xH4	3 interventions of the P6 protection in 60 minutes	The X represents the system: 1 is system A, 2 is system B. The error cannot be reset until the system is restarted
H5	3 interventions of the P2 protection in 60 minutes	The error cannot be reset until the system is restarted
H6	3 interventions of the P4 protection in 100 minutes	The error cannot be reset until the system is restarted
H7	Error of decreasing the number of indoor units	The loss of one or more indoor units for more than 3 minutes is an error that cannot be reset until return of the correct number of units
H9	3 interventions of the P9 protection in 60 minutes	The error cannot be reset until the system is restarted
dF	Defrosting	
d0	Return of the oil	
P1	High pressure protection or discharge temperature protection	
P2	Low pressure protection	
xP3	Compressor current protection	The X represents the system: 1 is system A, 2 is system B
P4	High discharge temperature protection	
P5	Condenser high temperature protection	
xP6	Inverter module protection	The X represents the system: 1 is system A, 2 is system B
P9	DC fan protection	
PE	Evaporator high temperature protection T2	
PL	Inverter module temperature protection	
C7	3 interventions of the PL protection in 90 minutes	The error cannot be reset until the system is restarted
xL0	DC compressor module error	The X represents the system: 1 is system A, 2 is system B
xL1	DC bus low pressure protection	The X represents the system: 1 is system A, 2 is system B
xL2	DC bus high pressure protection	The X represents the system: 1 is system A, 2 is system B
xL4	MCE malfunction/simultaneous activation/cyclical activation in loop	The X represents the system: 1 is system A, 2 is system B
xL5	Zero speed protection	The X represents the system: 1 is system A, 2 is system B
xL7	Compressor phase error protection	The X represents the system: 1 is system A, 2 is system B
xL8	Difference of more than 15 rpm in compressor speed in one second	The X represents the system: 1 is system A, 2 is system B
xL9	Difference of more than 15 rpm between the set speed and the operating speed of the compressor	The X represents the system: 1 is system A, 2 is system B



WARNING

If there are any error or protection codes, contact your dealer for service and maintenance.

Error codes P6, L0 ~ L9 cannot be displayed automatically, these error codes will only be displayed by pressing the SW3 button (press SW3 ten times, once per second).

The large capacity V4+ system (56-90kW) has an automatic refrigerant volume assessment function.

When all the indoor units are in cooling or heating mode, the system will automatically operate in volume assessment mode.

If the system detects that the refrigerant volume is normal, the system will operate normally and no error code will be displayed. If the system detects that the refrigerant volume is abnormal, the corresponding error code will be displayed.

When only some indoor units are in cooling or heating mode, the system will not assess the refrigerant volume and the display will show the last assessment result.

Code	Description
r1	Lack of refrigerant
r2	Clear lack of refrigerant
r3	Severe lack of refrigerant
R1	Too much refrigerant
R2	Serious excess of refrigerant

8 START-UP

8.1 Start-up preparations

After installation and configuration of the settings, the personnel must check that these have been carried out correctly. Therefore, the steps below must be followed to perform the test run.

The test can be carried out once installation is complete. The test generally involves the following steps:

- Read the “Checklist before execution of the test”.
- Carry out the operating test.
- Correct any errors before the test can end with exceptions.
- Run the system



WARNING

During the test, the outdoor unit runs at the same time as the indoor units connected to it. It is very dangerous to perform debugging of the indoor unit during the test. Do not remove the cover of the fan. The fan can cause physical injury when running at high speed.



CAUTION

Make sure that the insulation to earth is at least 1 M Ω



WARNING

Make sure that power is supplied to the unit at least 12 hours before starting it so that the casing heater can run effectively to protect the compressor.



WARNING

The test can be carried out when the room temperature is between -20 °C and 35 °C.



WARNING

The operating test can only be carried out when all the valves are open.



CAUTION

Never force switch-on. (Disabling the protection device can lead to dangerous situations.)

During the tests, the outdoor unit and the indoor one start at the same time. Make sure that all the preparations for the indoor unit have been completed. Refer to the installation manual of the indoor unit for the pertinent information

8.1.1 Checklist before running the test

After installing the unit, first check the following points. After carrying out all the checks below, turn off the unit. This is the only way to restart the unit.

Carry out the following checks:

- Check mechanical assembly of the outdoor unit.**
See “3 Installation” page 13
- Check that the electrical wiring has been done correctly.**
See “5 Electrical connections” page 30
- Check that the refrigerant piping has been installed correctly.**
See “4 Refrigerant piping” page 18
- Checking the power supply voltage**
The voltage must be the same as the one indicated on the identification plate
- Checking the earth line**
Make sure that the earth line is connected properly and that the earth terminal is watertight
- Insulation test of the main circuit**
Use the DC500 of 500V, apply a voltage of 500V DC between the power supply terminal and the earth terminal. Check that the insulation resistance is above M 2. Do not use the DC500 on the transmission line
- Fuses, switches or protective devices**
Check that the fuses, automatic switches and protective devices installed locally are compliant with the safety directives
- Internal wiring**
Visually check that the connections between the box of the electrical components and the inside of the unit are aligned and that the electrical components are not damaged
- Stop valve**
Make sure that the stop valve is open on the liquid side and that of the gas
- Damage to the equipment**
Check that there are no damaged components and extruded pipes in the unit
- Refrigerant leak**
Check that refrigerant is not leaking inside the unit
- Check the system for gas leaks**
See “6.2 Gas leak test” page 38
- Oil leaks**
Check that oil is not leaking out of the compressor
- Air inlet/outlet**
Check for any material that could obstruct the flow of air in and out of the equipment
- Top up the refrigerant**
The amount of refrigerant added to the unit must be noted on the “Confirmation table” on the front cover of the control unit electric

- Installation data and field settings**
Make sure that the date of installation is recorded on the label of the electrical appliance and the field settings are recorded.
- Before start-up, set the address of the outdoor unit**
See paragraph [“8.3 Automatic addressing procedure for indoor units \(400T to 450T\)”](#) page 52
- Check that the power of the outdoor unit is correct**
See paragraph [“2.2 Unit dimensions”](#) page 11

**WARNING**

Make sure you have a cylinder of R410A refrigerant gas available.

**WARNING**

Make sure you have the complete system layout, piping and wiring diagrams.

8.1.2 Information on performing the test

The following procedures relate to testing of the entire system.

The following are to be done:

- Check for wiring errors (by checking communication of the indoor unit).
- Check whether the shut-off valve is open.
- Determine the length of the pipe.

**WARNING**

Before starting the compressor, it may be necessary to wait 10 minutes for a state of uniform cooling to be reached.

During the test, the sound associated with cooling mode or with the solenoid valve could become louder and there may be changes to the indicators. This does not mean there is a malfunction.

8.1.3 Rectifications after the test

When an error code appears on the user interface or outdoor unit, make the necessary correction referring to the description in the table of error codes (See paragraph [“7.1.2 Error codes”](#) page 48). Repeat the test to check that the exception has been corrected.

8.2 Commissioning



WARNING

It is necessary to fill in the commissioning report as a record of the operating status of the system once the procedure is completed.



WARNING

If the combination ratio is less than 100%, start all the indoor units. If the ratio exceeds 100%, start all the indoor units with total power equal to the total power of the outdoor unit.

Carry out the following procedure:

- Open the gas and refrigerant valves of the outdoor unit;
- start the outdoor unit;

8.3 Automatic addressing procedure for indoor units (400T to 450T)

- Turn off the outdoor unit (ODUs) and all indoor units (IDUs);
- Set the S6 switch on the outdoor unit to «Clean indoor units addresses»;
- Check that the S7 switches are all in the OFF position;
- Power up all the indoor units and wait at least 20 seconds;
- Power up all the outdoor units and wait at least 60 seconds;
- Disconnect only the outdoor units and wait at least 60 seconds;
- After this time has elapsed, set the S6 switch to «Auto Addressing» and then power up the outdoor unit again;
- Wait for the addressing operation to be completed: the operation ends when all the indoor units have the «operation» LED flashing slowly and (if they have a display) the two dashes «-» in steady state;

9 MAINTENANCE

It is good practice to periodically clean both the internal and external parts of the appliance. This guarantees its proper operation and durability.

Carry out periodic maintenance of the appliance in accordance with the regulations in force.

Maintenance must be carried out by qualified technical personnel.

Improper maintenance or service can cause electric shock, fire or water leakage.



ATTENTION ELECTRIC DANGER

Before cleaning or maintenance, always switch off the air conditioner and disconnect it from the power supply.

This unit contains R410A fluorinated gas. It is forbidden to release it into the environment.

The GWP (Global warming potential) over a temporal period of 100 years is equal to 2090 units

As it does not contain chlorine atoms, this mixture does not damage the ozone layer.

For equipment that contains fluorinated greenhouse gases in quantities of 5 tons of CO₂ or more but in any case less than 50 tons, a test must be carried out to check for the leaking of refrigerant once every 12 months. If a leak detection system is installed, the test must be carried out every 24 months.

For equipment that contains fluorinated greenhouse gases in quantities of 50 tons of CO₂ or more but in any case less than 500 tons, a test must be carried out to check for the leaking of refrigerant once every 6 months. If a leak detection system is installed, the test must be carried out every 12 months.



WARNING

Do not check or repair the unit yourself. Contact skilled professionals to carry out checks and repairs. Do not use substances such as petrol, thinners or chemical dust cloths to clean the appliance. This could remove the top layer of paint. If the unit is dirty, soak a cloth in diluted neutral detergent, wring it out to dry it and then clean the appliance with it. Lastly, dry it with a dry cloth.



CAUTION

If a fuse has blown, replace it with one with the same characteristics. Using electrical cables or copper wires can cause the unit to malfunction or start a fire.



CAUTION

Do not insert fingers, sticks or other objects into the air inlet or outlet. Do not remove the fan grille. The fan can cause personal injury when running at high speed.

It is extremely dangerous to check the unit when the fan is turning.

Always switch off the main switch before starting any maintenance work.

Check the unit's supporting structure and base for any damage after a long downtime.

The unit could fall and cause personal injury.

Discharge the pressure before disassembly.

Below are some modes that **do not** represent malfunctions

The outdoor unit makes a hissing noise . It can be caused:

- by expansion due to heat or by contraction due to cooling of the heat exchanger, depending on the temperature variations;
- at the beginning or at the end of the defrosting process, the 4-way valve may emit a sound similar to that emitted by a flow of water which will be amplified after a few minutes;
- by the flow of refrigerant or the discharge of drainage water;
- by operation of the drain pump (accessories on request).
- by a change in inverter frequency operation

The heat exchanger of the outdoor unit discharges mist or water. It can be caused:

- by defrosting of the outdoor unit.

Mist coming out of the outdoor unit.

- The heat produced by defrosting the outdoor unit evaporates the humidity on the coil.

The power indicator of the indoor unit flashes. It can be caused:

- by restarting after an abnormal shutdown;
- by mode conflict;
- by stopping of the fan to avoid spreading cold air.

Automatic starting or stopping. It can be caused:

- by activation of the timer.

The system is not working. It can be caused:

- by the lack of power;
- by closing of the manual power switch;
- by the presence of a blown fuse;
- by the presence of a time schedule;

- The air conditioner does not switch on immediately after pressing the ON/OFF button on the remote control;
- If the operation light is on, the system is operating normally. To prevent the compressor motor from overloading, the air conditioner switches on 3 minutes after the switch-on control.

Insufficient cooling or heating capacity. It can be caused:

- by dirt in the heat exchanger;
- by blockage of the unit's inlet, outlet or filter;
- by low fan speed;
- by the "fan only" operating mode;
- by inappropriate setting of the temperature.

The direction of the fan is not the same as the one set.

- The direction of air is not the same as the one on the user's front display.
- The direction of air does not oscillate, since the units are controlled by the centralised controller.

The speed of the fan is not the same as the one set.

- The speed of the fan does not change even when the fan speed adjustment button is pressed. When the indoor temperature reaches the setpoint during heating, the outdoor unit turns off and the indoor unit enters fan speed silent mode, to avoid the blowing of air directly at the user of the room. The speed of the fan does not change even when the button is pressed for another heating operation indoors.

Dust and dirt in the unit

- When the unit is used for the first time, because there is dust in the unit.

Strange smell from the unit

- This unit will absorb the smells of rooms, items of furniture, cigarettes and others, to then disperse them. Small animals that can enter the unit may cause smells.

The fan of the ODU does not work

- During operation. Check the speed of the fan motor to optimise operation of the product.

Hot air can be felt when the indoor unit stops

- There are different types of indoor unit in use in the same system. When another unit is in operation, part of the refrigerant continues to flow through this unit.

Switching from cooling mode to fan mode

- To prevent the internal evaporator from freezing, the system automatically switches to fan only mode and then switches back to cooling mode after a few minutes.

- If the temperature of the conditioned room reaches the set value, the compressor switches off and the indoor unit switches to fan mode; if the temperature rises again, the compressor will restart. This also occurs with heating mode.

9.1 Maintenance after shutting the unit down for a long period

For example, at the beginning of summer or winter.

- Check and remove all the objects that could obstruct the air inlets and outlets of the indoor and outdoor units.
- Contact maintenance personnel to clean the air filter and the casing of the outdoor unit. Make sure that the air filter is clean and installed properly.
- Connect the power supply 12 hours before the unit is to be used to ensure that the unit operates smoothly. At switch-on, the user interface is displayed.

9.2 Maintenance before the unit is shut down for a long period

For example, at the end of winter or summer.

- Operate the indoor unit in fan mode for about half a day to dry the internal parts of the unit.
- Disconnect the power supply
- Contact maintenance personnel to clean the air filter and the casing of the outdoor unit. Make sure that the air filter is clean and installed properly.

10 TROUBLESHOOTING

10.1 Operating problems and possible causes

If one of the malfunctions described below is encountered, switch off the air conditioner, disconnect it from the mains and contact an authorised technical service centre.

- The operation light flashes quickly (twice per second). It continues flashing even if the unit is switched off and back on again.
- The remote control does not receive the signals correctly or the button does not work properly.
- The fuse, circuit breaker or another safety device trips frequently.
- Water or foreign materials enter the unit.
- There are water leaks from the indoor unit.
- Other malfunctions.

If the system does not work properly and has the above faults or other types of problems, proceed as follows to try and find the causes.

Symptoms	Causes	Solution
The unit does not start	Power failure.	Wait for the power to return.
	The power supply switch is off.	Switch on the appliance.
	Blown fuse or faulty power switch.	Replace.
	Remote control batteries flat or other remote control problem.	Change the batteries or check the remote control.
Air circulates normally but cooling is insufficient	The temperature is not set correctly.	Set the correct temperature.
	Compressor protection with 3-minute delay is active.	Wait.
The unit starts or stops frequently	The amount of refrigerant is insufficient or excessive.	Check for leaks and top up the refrigerant.
	Air or no gas in the refrigerant circuit.	Bleed the circuit and recharge the refrigerant
	Compressor malfunction	Have the compressor repaired or replaced.
	Voltage too high or too low.	Install a pressure switch.
	System circuit blocked.	Find the causes and fix them.
Limited cooling effect	The heat exchangers of the outdoor unit and indoor unit are dirty.	Clean the heat exchanger.
	The air filter is dirty	Clean the air filter
	Indoor/outdoor units' inlet/outlet obstructed.	Remove all the residues to allow the air to circulate freely.
	Doors or windows open.	Close doors and windows.
	Direct exposure to sunlight.	Fit a curtain to reduce exposure to sunlight.
	Too many heat sources.	Reduce the heat sources.
	Outdoor air too high.	The cooling capacity of the air conditioner has lowered (normal).
Refrigerant leaks or insufficient amount of refrigerant.	Check for leaks and top up the refrigerant.	
Limited heating effect	The outdoor temperature is lower than 7 °C.	Use the heating function.
	Doors and windows not completely closed.	Close doors and windows.
	Refrigerant leaks or insufficient amount of refrigerant.	Check for leaks and top up the refrigerant.

10.2 Remote control operating problems and possible causes

Symptoms	Causes	Solution
The fan speed cannot be adjusted.	Check if the indicated mode on the display is "AUTO" (automatic).	If automatic mode is selected, the air conditioner automatically adjusts the fan speed.
	Check if the mode shown on the display is "DRY" (dehumidification)	If dry (dehumidification) mode is selected, the air conditioner automatically adjusts the fan speed. The fan speed can be selected in "COOL", "FAN" and "HEAT" mode.
The remote control signal is not transmitted, even if the ON/OFF button is pressed.	Check that the remote control batteries are not flat.	The appliance is switched off.
The TEMP. indicator does not switch on.	Check if the mode shown on the display is "FAN".	The temperature cannot be set in fan mode.
The indication on the display disappears after a set time.	Check that the appliance has switched off at the time shown on the switch-off timer display (TIMER OFF function).	The air conditioner switches off at the set time.
The switch-on timer indicator (TIMER ON function) switches off after a set time.	Check if the TIMER ON indication appears on the display.	At the time set with the timer, the air conditioner will automatically switch on and the corresponding indicator will switch off.
The indoor unit does not emit any sound, not even when the ON/OFF button is pressed.	Check that the remote control signal transmitter is correctly directed towards the infrared signal receiver on the indoor unit when the ON/OFF button is pressed.	Directly transmit the remote control signal to the indoor unit signal receiver, then press the ON/OFF button twice.

11 DISPOSAL

The manufacturer is registered on the National EEE Register, in compliance with implementation of Directive 2012/19/EU and pertinent national regulations on electrical and electronic equipment waste.

This Directive requires electrical and electronic equipment to be disposed of properly.

Equipment bearing the crossed-out wheelee bin symbol must be disposed of separately at the end of its lifecycle to prevent damage to human health and to the environment.

Electrical and electronic equipment must be disposed of together with all of its parts.

To dispose of “household” electrical and electronic equipment, the manufacturer recommends contacting an authorised dealer or an authorised ecological site.

“Professional” electrical and electronic equipment must be disposed of by authorised personnel through established waste disposal authorities around the country.

In this regard, here is the definition of household WEEE and professional WEEE.

WEEE from private households: WEEE originating from private households and WEEE which comes from commercial, industrial, institutional and other sources which, because of its nature and quantity, is similar to that from private households. Subject to the nature and quantity, where the waste from EEE was likely to have been used by both a private household and users of other than private households, it will be classed as private household WEEE;

Professional WEEE: all WEEE which comes from something other than private households.

This equipment may contain:

- refrigerant gas, the entire contents of which must be recovered in suitable containers by specialised personnel with the necessary qualifications;
- lubrication oil contained in compressors and in the refrigeration circuit to be collected;
- mixtures with antifreeze in the water circuit, the contents of which are to be collected;
- mechanical and electrical parts to be separated and disposed of as authorised.

When the components to be replaced for maintenance purposes are removed or when the entire unit reaches the end of its life and needs to be removed from the installation, waste should be separated by its nature and disposed of by authorised personnel at existing collection centres.



FOR 30 YEARS WE HAVE BEEN OFFERING
SOLUTIONS FOR SUSTAINABLE COMFORT
THE WELL-BEING OF PEOPLE AND
THE ENVIRONMENT

www.clivet.com

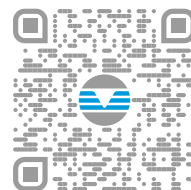

sales and service



CLIVET SPA
Via Camp Lonc 25, Z.I. Villapaiera
32032 Feltre (BL) - Italy
Tel. +39 0439 3131 - Fax +39 0439 313300
info@clivet.it

MideaGroup
humanizing technology