

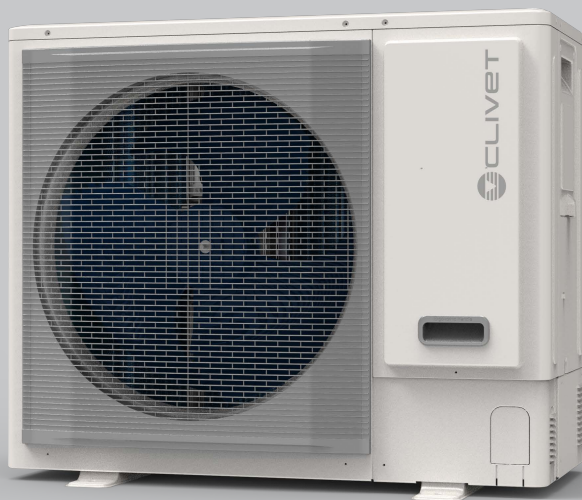

Mini VRF

MSAN8-X 80M ÷ 160T



TECHNICAL BULLETIN



CONTENTS

Part 1 General Information	3
Part 2 Outdoor Unit Engineering Date.....	18
Part 3 System Design and Installation	77

Part 1

General Information

1 Indoor and Outdoor Unit Capacities.....	4
2 External Appearance.....	6
3 Nomenclature.....	8
4 Combination Ratio.....	11
5 Selection Procedure.....	13

1 Indoor and Outdoor Unit Capacities

1.1 Indoor Units

1.1.1 Standard indoor units

Table 1-1.1: Standard indoor unit abbreviation codes

ABBREVIATION CODE	TYPE	ABBREVIATION CODE	TYPE
Q1DN	One-way Cassette	CN	High Static Pressure Duct
Q2DN	Two-way Cassette	GWMN	Wall-mounted
Q4AN	Compact Four-way Cassette	DDLC	Ceiling & Floor
Q4DN	Four-way Cassette	DZ	Floor Standing
CNT2	Medium Static Pressure Duct		

Table 1-1.2: Standard indoor unit capacity range

Capacity		Capacity index	Q1DN	Q2DN	Q4AN	Q4DN	CNT2	CN	GWMN	DDLC	DZ
KW	HP										
1.7	0.5	17	-	-	17	-	17	-	17	-	-
1.8	0.6	18	18	-	-	-	-	-	-	-	-
2.2	0.8	22	22	22	22	-	22	-	22	-	22
2.8	1	28	28	28	28	28	28	-	28	-	28
3.6	1.25	36	36	36	36	36	36	-	36	36	36
4.5	1.6	45	45	45	45	45	45	-	45	45	45
5.2	1.9	52	-	-	52	-	-	-	-	-	-
5.6	2	56	56	56	-	56	56	-	56	56	56
7.1	2.5	71	71	71	-	71	71	71	71	71	71
8.0	3	80	-	-	-	80	80	80	80	80	80
9.0	3.2	90	-	-	-	90	90	90	90	90	-
10.0	3.6	100	-	-	-	100	-	-	-	-	-
11.2	4	112	-	-	-	112	112	112	-	112	-
14.0	5	140	-	-	-	140	140	140	-	140	-
14.0	6	160	-	-	-	-	-	160	-	-	-
20.0	7	200	-	-	-	-	-	200	-	-	-
25.0	9	250	-	-	-	-	-	250	-	-	-
28.0	10	280	-	-	-	-	-	280	-	-	-
40.0	14	400	-	-	-	-	-	400	-	-	-
45.0	16	450	-	-	-	-	-	450	-	-	-
56.0	20	560	-	-	-	-	-	560	-	-	-

1.1.2 Fresh air processing unit

Table 1-1.3: Fresh air processing unit capacity range

Capacity	12.5kW	14kW
Capacity index	125	140

1.2 Heat recovery ventilator

Table 1-1.4: Heat recovery ventilator capacity range

Capacity	200m ³ /h	300m ³ /h	400m ³ /h	500m ³ /h	800m ³ /h	1000m ³ /h	1500m ³ /h	2000m ³ /h
----------	----------------------	----------------------	----------------------	----------------------	----------------------	-----------------------	-----------------------	-----------------------

1.3 Outdoor Units

Table 1-1.5: Outdoor unit capacity range

Capacity(kW)	Model Name
7.2 - 1Ph	MSAN8-X 80M
9.0 - 1Ph	MSAN8-X 100M
12.3 - 1Ph	MSAN8-X 120M
14.0 - 1Ph	MSAN8-X 140M
15.5 - 1Ph	MSAN8-X 160M
12.3 - 3Ph	MSAN8-X 120T
14.0 - 3Ph	MSAN8-X 140T
15.5 - 3Ph	MSAN8-X 160T

2 External Appearance

2.1 Indoor Units

2.1.1 Standard indoor units

Table 1-2.1: Standard indoor unit appearance

<p>One-way Cassette</p> <p>Q1DN</p> 	<p>Two-way cassette</p> <p>Q2DN</p> 
<p>Compact Four-way Cassette</p> <p>Q4AN</p> 	<p>Four-way Cassette</p> <p>Q4DN</p> 
<p>Medium Static Pressure Duct</p> <p>CNT2</p> 	<p>High Static Pressure Duct</p> <p>CN</p> 
<p>Wall-mounted</p> <p>GWMN</p> 	<p>Ceiling & Floor</p> <p>DDL</p> 
<p>Floor Standing</p> <p>DZ</p> 	

2.1.2 Fresh air processing unit

Table 1-2.2: Fresh air processing unit appearance



2.2 Heat Recovery Ventilator

Table 1-2.3: Heat recovery ventilator appearance



2.3 Outdoor Units

Table 1-2.4: outdoor unit appearance

80M-160M / 120T-160T



3 Nomenclature

3.1 Indoor Units

3.1.1 Standard indoor units

Q1DN - 2 - X M i D 22
 ① ② ③ ④ ⑤ ⑥ ⑦

Legend		
NO.	Code	Remarks
1	Q1DN	Indoor unit type Q1DN: One-way Cassette Q2DN: Two-way Cassette Q4AN: Four-way Cassette Compact Q4DN: Four-way Cassette CNT2: Medium Static Pressure Duct CN: High Static Pressure Duct GWMN: Wall-mounted DDLCL: Ceiling & Floor DZ: Floor Standing
2	2	2nd generation indoor unit
3	X	R410A
4	M	Midea
5	i	Inverter
6	D	Series category (D: DC series)
7	22	Capacity index (the capacity in kW multiplied by 10)

Fresh air processing unit

CNFA - 2 X M i D 280
 ① ② ③ ④ ⑤ ⑥ ⑦

Legend		
NO.	Code	Remarks
1	CNFA	Fresh Air Processing Unit
2	2	2nd generation indoor unit
3	X	R410A
4	M	Midea
5	i	Inverter
6	D	Series category (D: DC series)
7	280	Capacity index (the capacity in kW multiplied by 10)

3.1.2 Fresh air processing unit

HRV = 2 = M i D 200
 ① ② ③ ④ ⑤ ⑥

Legend		
NO.	Code	Remarks
1	HRV	Heat recovery ventilator
2	2	2nd generation indoor unit
3	M	Midea
4	i	Inverter
5	D	Series category (D: DC series)
6	200	Airflow in m ³ /h

3.2 Outdoor Units

M S A N 8 - X 80M
 ① ② ③ ④ ⑤ ⑥ ⑦ ⑧

Legend		
NO.	Code	Remarks
1	M	Condensing unit
2	S	Scroll
3	A	Air-source
4	N	heat pump
5	8	The 8th generation heat pump VRF
6	X	R410A
7	80	Capacity index (The capacity in kW multiplied by 10)
8		Power supply M: 1 phase, 220-240V, 50 Hz T: 3 phase, 380-415V, 50 Hz

4 Combination Ratio

$$\text{Combination ratio} = \frac{\text{Sum of capacity indexes of the indoor units}}{\text{Capacity index of the outdoor units}}$$

Table 1-5.1: Indoor and outdoor unit combination ratio limitations

Type	Minimum combination ratio	Maximum combination ratio		
		Standard indoor units only	Fresh air processing units only	Fresh air processing units and standard indoor units together
V8 Series outdoor units	50%	130% ² or 160% ²	100%	100% ⁴

Notes:

- If all indoor units in system are V8 Series the total combination ratio must not exceed 160%. If there are non V8 series indoor unit in system the total combination ratio must not exceed 130%
- When fresh air processing units are installed together with standard indoor units, the total capacity of the fresh air processing units must not exceed 30% of the total capacity of the outdoor units and the total combination ratio must not exceed 100%.

Table 1-5.2: Combinations of indoor and outdoor units

Outdoor unit capacity		Sum of capacity indexes of connected indoor units (standard indoor units only)	Sum of capacity indexes of connected indoor units (fresh air processing units and standard indoor units together)	Maximum number of connected indoor units
model	Capacity index			
80M	72	36 to 93.6	36 to 72	5
100M	90	45 to 117	45 to 90	6
120M	123	61.5 to 159.9	61.5 to 123	8
140M	140	70 to 182	70 to 140	10
160M	155	77.5 to 201.5	77.5 to 155	11
120T	123	61.5 to 159.9	61.5 to 123	8
140T	140	70 to 182	70 to 140	10
160T	155	77.5 to 201.5	77.5 to 155	11

5 Selection Procedure

5.1 Procedure

Step 1: Establish design conditions

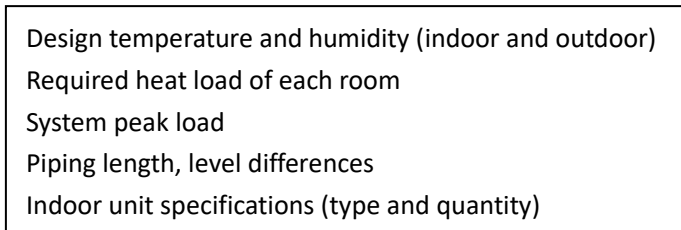

Step 2: Select indoor units

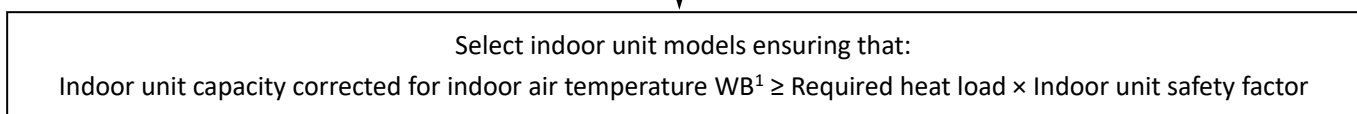
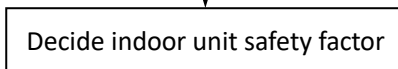

Step 3: Select outdoor units

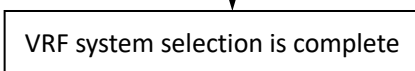
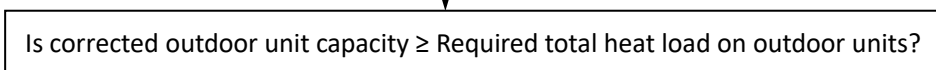
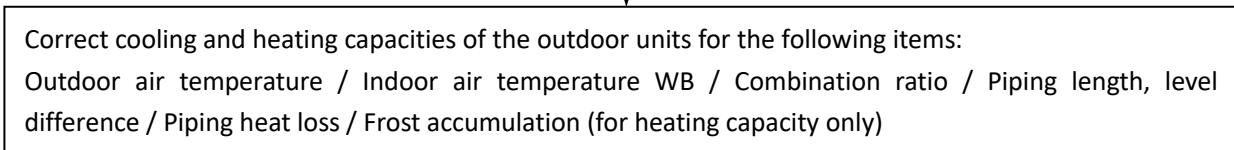
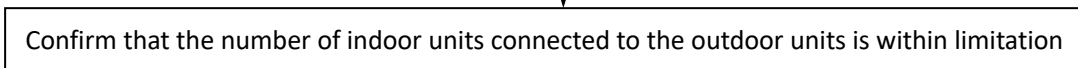
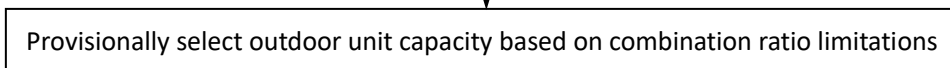
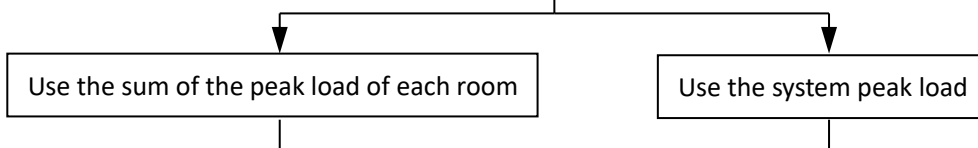
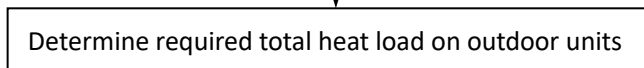

Notes:

1. If the indoor design temperature falls between two temperatures listed in the indoor unit's capacity table, calculate the corrected capacity by interpolation. If the indoor unit selection is to be based on total heat load and sensible heat load, select indoor units which satisfy not only the total heat load requirements of each room but also the sensible heat load requirements of each room. As with total heat capacity, the sensible heat capacity of indoor units should be corrected for indoor temperature, interpolating where necessary. For the indoor unit capacity tables, refer to the indoor unit technical manuals.

5.2 Example

The following is a selection example based on total heat load for cooling.

Figure 1-5.1: Room plan

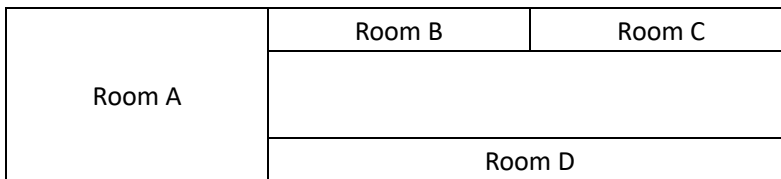

Step 1: Establish design conditions

- Indoor air temperature 25°C DB, 18°C WB; outdoor air temperature 33°C DB.
- Determine peak load of each room and system peak load. As shown in Table 1-5.1, the system peak load is 10.5kW.

Table 1-5.1: Required heat load of each room (kW)

Time	Room A	Room B	Room C	Room D	Total
9:00	2.5	1.6	1.6	1.6	7.3
12:00	3.2	2.4	2.4	2.4	10.4
14:00	3.1	2.4	2.4	2.6	10.5
16:00	3.1	2.3	2.3	2.3	10

- The maximum piping lengths and level differences in this example are as given in Figure 1-5.2.

Figure 1-5.2: System diagram

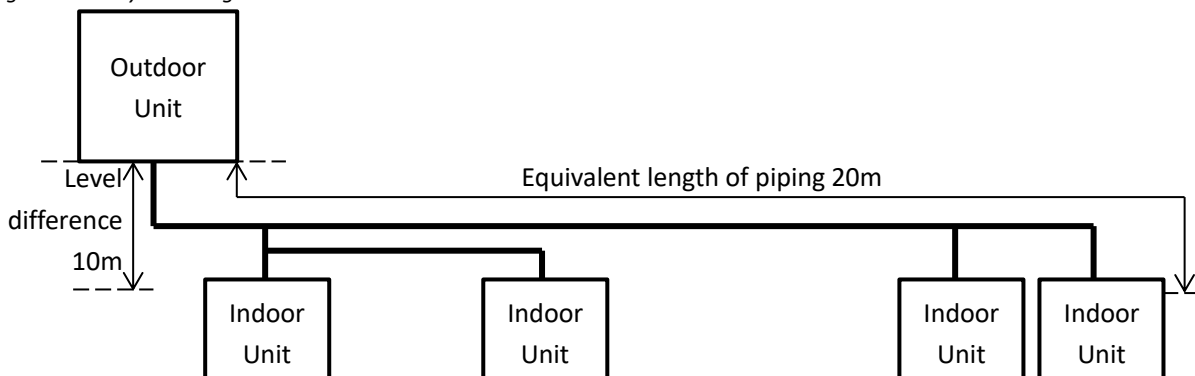

- Indoor unit type for all rooms: Medium Static Pressure Duct (CNT2).

Step 2: Select indoor units

- In this example, a safety factor is not used (i.e. the safety factor is 1).
- Select indoor unit models using the medium static pressure duct cooling capacity table. Each indoor unit's corrected capacity needs to be greater than or equal to the peak load of the relevant room. The selected indoor units are shown in Table 1-5.3.

Table 1-5.2: Extract from medium static pressure duct (CNT2) cooling capacity table

Model	Capacity index	Indoor air temperature													
		14°C WB		16°C WB		18°C WB		19°C WB		20°C WB		22°C WB		24°C WB	
		20°C DB		23°C DB		26°C DB		27°C DB		28°C DB		30°C DB		32°C DB	
		TC	SC	TC	SC	TC	SC	TC	SC	TC	SC	TC	SC	TC	SC
CNT2	22	1.5	1.4	1.8	1.5	2.1	1.6	2.2	1.6	2.3	1.7	2.4	1.5	2.4	1.5
	28	1.9	1.7	2.3	1.9	2.6	2.1	2.8	2.1	3.0	2.1	3.1	2.0	3.1	1.9
	36	2.5	2.1	2.9	2.3	3.4	2.5	3.6	2.6	3.8	2.7	4.2	2.8	3.9	2.3
	45	3.1	2.6	3.7	2.8	4.2	3.1	4.5	3.2	4.8	3.2	4.9	3.1	5.1	2.9
	56	3.9	3.0	4.6	3.3	5.3	3.6	5.6	3.7	5.9	3.8	6.2	3.7	6.2	3.4
	71	4.9	3.9	5.8	4.3	6.7	4.7	7.1	4.9	7.5	4.8	7.8	4.6	7.8	4.3
	80	5.5	4.4	6.6	4.9	7.5	5.3	8.0	5.5	8.4	5.5	8.8	5.2	8.8	4.8
	90	6.2	5.3	7.3	5.8	8.4	6.3	9.0	6.4	9.6	6.5	9.9	6.1	9.9	5.7
	112	7.7	6.4	9.1	7.1	10.5	7.7	11.2	7.8	11.9	8.1	12.5	7.8	12.5	7.4
	140	9.7	7.8	11.3	8.6	13.2	9.6	14.0	9.8	14.8	9.8	15.7	9.7	15.4	8.8

Abbreviations:

TC: Total capacity (kW); SC: Sensible capacity (kW)

Table 1-5.3: Selected indoor units

	Room A	Room B	Room C	Room D
Peak heat load (kW)	3.1	2.4	2.4	2.6
Selected indoor unit	CNT2-2-XMi D36	CNT2-2-XMi D28	CNT2-2-XMi D28	CNT2-2-XMi D28
Corrected TC (kW)	3.6	2.8	2.8	2.8

Step 3: Select outdoor units

- Determine the required total heat load from the indoor units to the outdoor unit based on either the sum of the peak loads of each room or the system peak load. In this example, it is determined based on the system peak load. Therefore, the required heat load is 10.5kW.
- Provisionally select an outdoor unit using the sum of the capacity indexes (CIs) of the selected indoor units (as shown in Table 1-5.4), ensuring that the combination ratio is between 50% and 130%. Refer to Table 1-5.5. As the sum of CIs of the indoor units is 120, all outdoor units are potentially suitable except 8 and 9kW. Start from the smaller, which is the 12.3 kW unit.

Table 1-5.4: Sum of indoor unit capacity indexes

Model	Capacity Index	No. of units
CNT2-2-XMi D36	36	1
CNT2-2-XMi D28	28	3

Sum of CIs	120
------------	-----

Table 1-5.5: Combinations of Indoor and outdoor units

Outdoor unit capacity		Sum of capacity indexes of connected indoor units (standard indoor units only)
model	Capacity index	
80M	72	36 to 93.6
100M	90	45 to 117
120M	123	61.5 to 159.9
140M	140	70 to 182
160M	155	77.5 to 201.5
120T	123	61.5 to 159.9
140T	140	70 to 182
160T	155	77.5 to 201.5

- The number of connected indoor units is 4 and the maximum number of connected indoor units on the 120 model outdoor unit is 8, so the number of connected indoor units is within the limitation.
- Calculate the corrected capacity of the outdoor unit:
 - a) The sum of the indoor unit CIs is 120 and the CI of the 120 model outdoor unit is 123, so the combination ratio is $120 / 123 = 97.5\%$.
 - b) Using the outdoor unit's cooling capacity table, interpolate to obtain the capacity ("B") corrected for outdoor air temperature, indoor air temperature, and combination ratio. Refer to Tables 1-5.6 and 1-5.7.

Table 1-5.6: Extract from Table 2-8.7
MSAN8-X 120M cooling capacity

CR	Outdoor air temp. (°C DB)	Indoor air temp. (°C DB / °C WB)	
		25.8 / 18.0	
		TC	PI
		kW	kW
100%	31	11.4	3.0
	33	11.4	3.3
	35	11.4	3.5
90%	31	10.2	2.6
	33	10.2	2.8
	35	10.2	3.0

Table 1-5.7: Cooling capacity calculated by interpolation

CR	Outdoor air temp. (°C DB)	Indoor air temp. (°C DB / °C WB)	
		25.8 / 18.0	
		TC	PI
		kW	kW
130%	33	11.4	3.3
		B = 11.1¹	
120%	33	10.2	2.8

Notes:

1. $10.2 + (11.4 - 10.2) \times (97.5 - 90) / (100 - 90) = 11.1$

c) Find the correction factor for piping length and level difference (“K1”)

Figure 1-5.3: Mini rate of change in cooling capacity

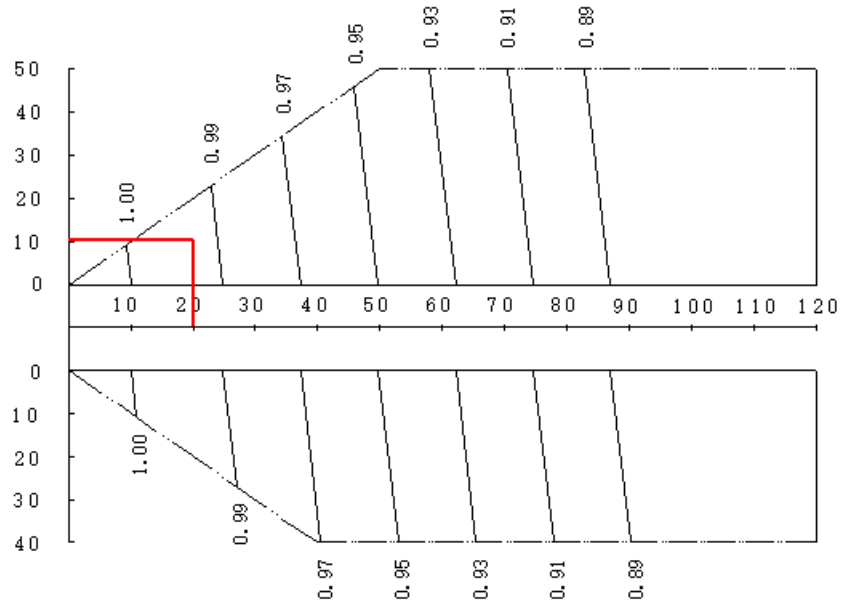

Notes:

1. The horizontal axis shows equivalent length of piping between farthest indoor unit and first outdoor branch joint; the vertical axis shows the largest level difference between indoor unit and outdoor unit. For level differences, positive values indicate that the outdoor unit is above the indoor unit, negative values indicate that the outdoor unit is below the indoor unit.

d) Calculate the corrected capacity of MSAN8-X 120M (“C”) by using K1:

$$C = B \times K1 = 11.1 \times 0.99 = 10.99\text{kW}$$

- The corrected capacity 10.99kW is larger than required total heat load 10.5kW, so selection is complete. (In the event that the corrected capacity is lower than the required total heat load, Step 3 should be repeated from the point where the outdoor unit capacity is provisionally selected.)

Part 2

Outdoor Unit

Engineering Data

1 Specifications.....	19
2 Dimensions.....	21
3 Installation Space Requirements.....	22
4 Piping Diagrams	23
5 Wiring Diagrams	26
6 Electrical Characteristics	28
7 Functional Components and Safety Devices	29
8 Capacity Tables	30
9 Operating Limits	73
10 Sound Levels	74
11 Accessories	76

1 Specifications

80M - 120M

Table 2-1.1: 80M-120M model specifications

Model			80	100	120
Model name			MSAN8-X 80M	MSAN8-X 100M	MSAN8-X 120M
Power supply			220-240V, ~, 50Hz		
Cooling	Capacity ^{1,2}	kW	7.2	9.0	12.3
	Power input ¹	kW	2.21	2.90	3.97
	EER ¹		3.26	3.10	3.10
	EER ²		4.20	4.12	4.06
Heating (Rated)	Capacity ^{3,4}	kW	7.2	9.0	12.3
	Power input ³	kW	1.80	2.37	3.00
	COP ³		4.00	3.80	4.10
	COP ⁴		4.80	4.25	4.35
Heating (Max)	Capacity ³	kW	9.0	10.8	14.0
	Power input ³	kW	2.50	3.18	3.78
	COP ³		3.60	3.40	3.70
SEER			5.40	5.40	7.20
$\eta_{s,c}$			/	/	285.0%
SCOP			3.80	3.80	4.90
$\eta_{s,h}$			/	/	193.0%
Connected indoor unit	Total capacity		50%-160% ⁷		
	Maximum quantity		5	6	8
Compressor	Type		DC		
	Quantity		1		
	Oil type		RB75EA		
	Start-up method		Soft start		
Fan	Type		Propeller		
	Motor type		DC		
	Quantity		1		
	Motor output	kW	0.2		
	Static pressure	Pa	0-35		
	Airflow rate	m ³ /h	5200	5200	5000
	Drive type		Direct		
Refrigerant	Type		R410A		
	Factory charge	kg	3.1	3.1	4.1
Pipe connections ⁵	Liquid pipe	mm	Φ9.52		
	Gas pipe	mm	Φ15.9		
Sound pressure level ⁶		dB(A)	53	53	55
Sound power level ⁶		dB(A)	70	72	72
Net dimensions (W×H×D)		mm	1038x864x523		
Packed dimensions (W×H×D)		mm	1120x980x560		
Net weight		kg	80	80	94
Gross weight		kg	90	90	104
Ambient temp.	Cooling	°C	-15°C~52°C ⁸		
operation range	Heating	°C	-20~16.5 °C (WB)/-20~30 °C (DB)		

Notes:

- Indoor air temperature 27°C DB, 19°C WB; outdoor air temperature 35°C DB; equivalent refrigerant piping length 5m with zero level difference. Data according to Eurovent test conditions.
- Indoor air temperature 27°C DB, 19°C WB; outdoor air temperature 35°C DB; equivalent refrigerant piping length 5m with zero level difference. Data according to EN 14511.
- Indoor air temperature 20°C DB; outdoor air temperature 7°C DB, 6°C WB; equivalent refrigerant piping length 5m with zero level difference. Data according to Eurovent test conditions.
- Indoor air temperature 20°C DB; outdoor air temperature 7°C DB, 6°C WB; equivalent refrigerant piping length 5m with zero level difference. Data according to EN 14511.
- Diameters given are those of the unit's stop valve. Refer to Part 3, "3 Refrigerant Piping Design" for installation dimensions of refrigerant pipe.
- Sound pressure level is measured at a position 1m in front of the unit and 1m above the floor in a semi-anechoic chamber.
- If there are non V8 series indoor units in system the total combination ratio must not exceed 130%
- Outdoor operating temperature under -5 °C in "cooling" mode, the startup capacity of IDUs must meet at least 30% of ODU capacity

140M -160M

Table 2-1.2: 140M-160M model specifications

Model			140	160
Model name			MSAN8-X 140M	MSAN8-X 160M
Power supply			220-240V, ~, 50Hz	
Cooling	Capacity ^{1,2}	kW	14.0	15.5
	Power input ¹	kW	5.19	5.96
	EER ¹		2.70	2.60
	EER ²		3.90	3.61
Heating (Rated)	Capacity ^{3,4}	kW	14.0	15.5
	Power input ³	kW	3.68	4.19
	COP ³		3.80	3.70
	COP ⁴		4.25	4.10
Heating (Max)	Capacity ³	kW	16.0	17.5
	Power input ³	kW	4.71	5.30
	COP ³		3.40	3.30
SEER			7.00	6.80
η _{s,c}			277.0%	269.0%
SCOP			4.80	4.80
η _{s,h}			189.0%	189.0%
Connected indoor unit	Total capacity		50%-160% ⁵	
	Maximum quantity		10	11
Compressor	Type		DC	
	Quantity		1	
	Oil type		RB75EA	
	Start-up method		Soft start	
Fan	Type		Propeller	
	Motor type		DC	
	Quantity		1	
	Motor output	kW	0.2	
	Static pressure	Pa	0-35	
	Airflow rate	m ³ /h	5000	5000
	Drive type		Direct	
Refrigerant	Type		R410A	
	Factory charge	kg	4.1	4.1
Pipe connections ³	Liquid pipe	mm	Φ9.52	Φ9.52
	Gas pipe	mm	Φ15.9	Φ15.9
Sound pressure level ⁴		dB(A)	56	56
Sound power level ⁴		dB(A)	73	74
Net dimensions (W×H×D)		mm	1038x864x523	
Packed dimensions (W×H×D)		mm	1120x980x560	
Net weight		kg	94	94
Gross weight		kg	104	104
Ambient temp.	Cooling	°C	-15°C~52°C ⁶	
operation range	Heating	°C	-20~16.5 °C (WB)/-20~30 °C (DB)	

Notes:

- Indoor air temperature 27°C DB, 19°C WB; outdoor air temperature 35°C DB; equivalent refrigerant piping length 5m with zero level difference. Data according to Eurovent test conditions.
- Indoor air temperature 27°C DB, 19°C WB; outdoor air temperature 35°C DB; equivalent refrigerant piping length 5m with zero level difference. Data according to EN 14511.
- Indoor air temperature 20°C DB; outdoor air temperature 7°C DB, 6°C WB; equivalent refrigerant piping length 5m with zero level difference. Data according to Eurovent test conditions.
- Indoor air temperature 20°C DB; outdoor air temperature 7°C DB, 6°C WB; equivalent refrigerant piping length 5m with zero level difference. Data according to EN 14511.
- Diameters given are those of the unit's stop valve. Refer to Part 3, "3 Refrigerant Piping Design" for installation dimensions of refrigerant pipe.
- Sound pressure level is measured at a position 1m in front of the unit and 1m above the floor in a semi-anechoic chamber.
- If there are non V8 series indoor units in system the total combination ratio must not exceed 130%
- Outdoor operating temperature under -5 °C in "cooling" mode, the startup capacity of IDUs must meet at least 30% of ODU capacity

120T -140T - 160T model

Table 2-1.2: 120T - 140T - 160T model specifications

Model			120	140	160
Model name			MSAN8-X 120T	MSAN8-X 140T	MSAN8-X 160T
Power supply			380-415V, 3N~, 50Hz		
Cooling	Capacity ^{1,2}	kW	12.3	14.0	15.5
	Power input ¹	kW	3.97	5.19	5.96
	EER ¹		3.10	2.70	2.60
	EER ²		4.06	3.90	3.61
Heating (Rated)	Capacity ^{3,4}	kW	12.3	14.0	15.5
	Power input ³	kW	3.00	3.68	4.19
	COP ³		4.10	3.80	3.70
	COP ⁴		4.35	4.25	4.10
Heating (Max)	Capacity ³	kW	14.0	16.0	17.5
	Power input ³	kW	3.78	4.71	5.30
	COP ³		3.70	3.40	3.30
SEER			7.20	7.00	6.80
η _{s,c}			285.0%	277.0%	269.0%
SCOP			4.90	4.80	4.80
η _{s,h}			193.0%	189.0%	189.0%
Connected indoor unit	Total capacity		50%-160% ⁵		
	Maximum quantity		8	10	11
Compressor	Type		DC		
	Quantity		1		
	Oil type		RB75EA		
	Start-up method		Soft start		
Fan	Type		Propeller		
	Motor type		DC		
	Quantity		1		
	Motor output	kW	0.2		
	Static pressure	Pa	0-35		
	Airflow rate	m ³ /h	5000	5000	5000
	Drive type		Direct		
Refrigerant	Type		R410A		
	Factory charge	kg	4.1	4.1	4.1
Pipe connections ³	Liquid pipe	mm	Φ9.52		
	Gas pipe	mm	Φ15.9		
Sound pressure level ⁴		dB(A)	55	56	56
Sound power level ⁴		dB(A)	72	73	74
Net dimensions (W×H×D)		mm	1038x864x523		
Packed dimensions (W×H×D)		mm	1120x980x560		
Net weight		kg	109	109	109
Gross weight		kg	119	119	119
Ambient temp.	Cooling	°C	-15°C~52°C ⁶		
operation range	Heating	°C	-20~16.5 °C (WB)/-20~30 °C (DB)		

Notes:

- Indoor air temperature 27°C DB, 19°C WB; outdoor air temperature 35°C DB; equivalent refrigerant piping length 5m with zero level difference. Data according to Eurovent test conditions.
- Indoor air temperature 27°C DB, 19°C WB; outdoor air temperature 35°C DB; equivalent refrigerant piping length 5m with zero level difference. Data according to EN 14511.
- Indoor air temperature 20°C DB; outdoor air temperature 7°C DB, 6°C WB; equivalent refrigerant piping length 5m with zero level difference. Data according to Eurovent test conditions.
- Indoor air temperature 20°C DB; outdoor air temperature 7°C DB, 6°C WB; equivalent refrigerant piping length 5m with zero level difference. Data according to EN 14511.
- Diameters given are those of the unit's stop valve. Refer to Part 3, "3 Refrigerant Piping Design" for installation dimensions of refrigerant pipe.
- Sound pressure level is measured at a position 1m in front of the unit and 1m above the floor in a semi-anechoic chamber.
- If there are non V8 series indoor units in system the total combination ratio must not exceed 130%
- Outdoor operating temperature under -5 °C in "cooling" mode, the startup capacity of IDUs must meet at least 30% of ODU capacity

2 Dimensions

2.1 Single Units

80M-160M / 120T-160T

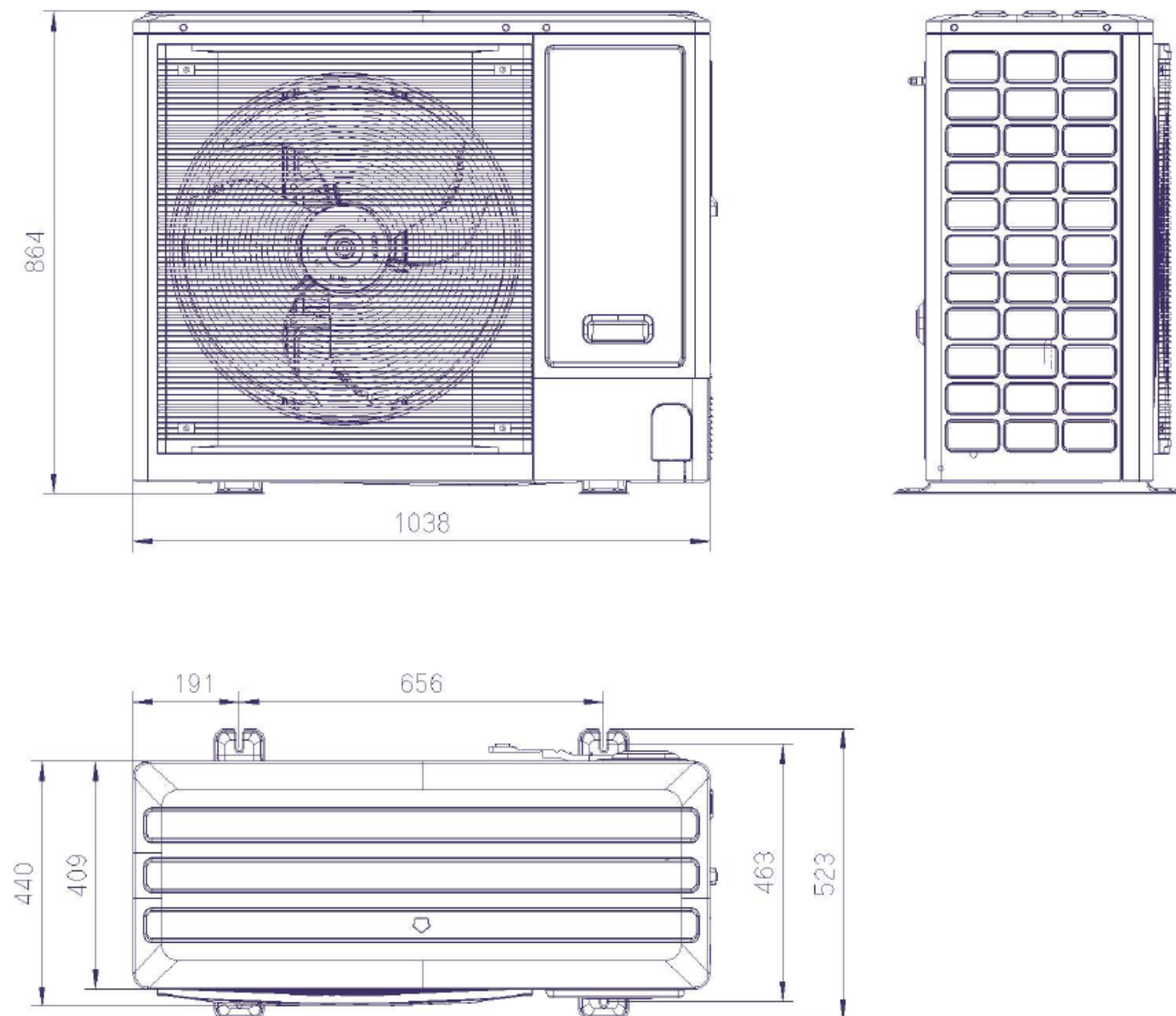

3 Installation Space Requirements

Figure 2-3.1: Single unit installation (unit: mm)

- Single unit installation

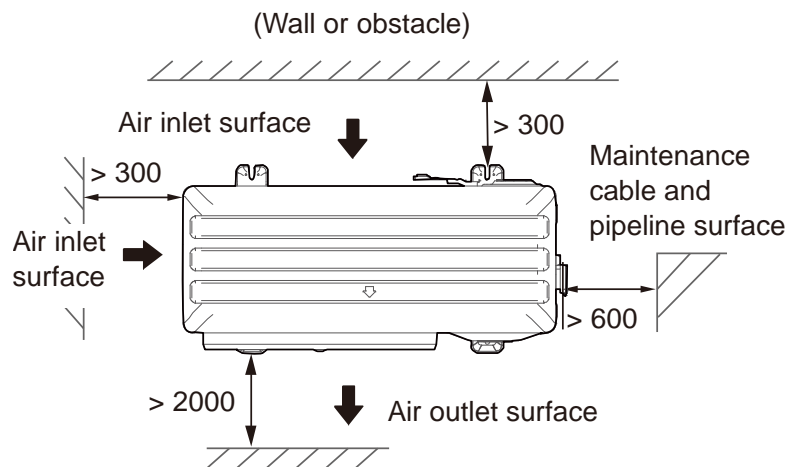
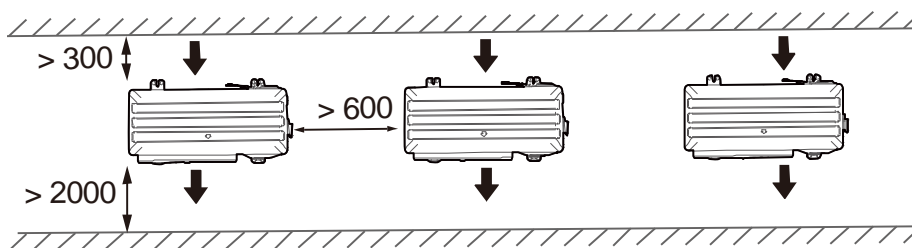
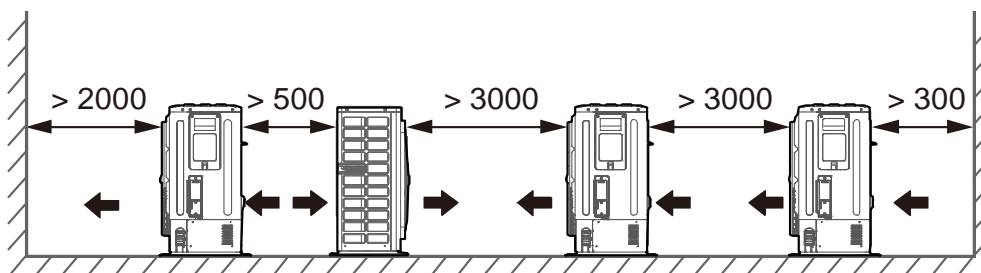

Figure 2-3.2: Multiple unit installation (unit: mm)

- Parallel connect the two units or above



- Parallel connect the front with rear sides



4 Piping Diagrams

80/100 model - 220-240V~50Hz

Figure 2-4.1: 80/100 model piping diagram

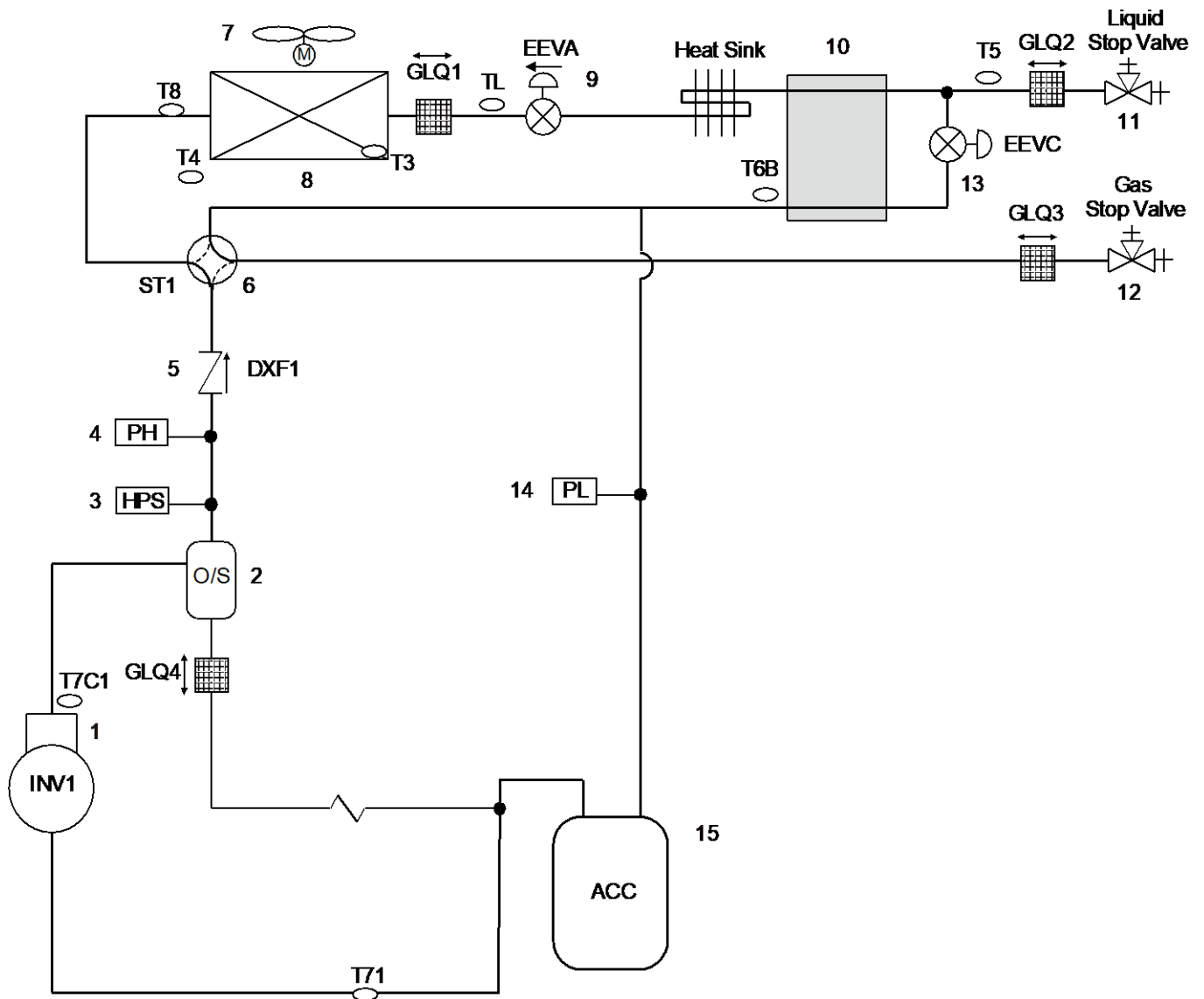

Legend			
No.	Parts name	No.	Parts name
1	Compressor	13	Electronic expansion valve (EEVC)
2	Oil separator	14	Low pressure sensor
3	High pressure switch	15	Gas-liquid separator
4	High pressure sensor		
5	Check value	Sensor Code	Description
6	Four-way valve(ST1)	T3	Main heat exchanger pipe temperature sensor
7	Fan	T4	Outdoor ambient temperature sensor
8	Heat exchanger	T5	Liquid pipe temperature sensor
9	Electronic expansion valve (EEVA)	T6B	Plate heat exchanger outlet temperature sensor
10	Plate heat exchanger	T7C1	Compressor discharge temperature sensor
11	Stop valve (liquid side)	T71	Suction temperature sensor
12	Stop valve (gas side)	T8	Condenser inlet temperature sensor
		TL	Condenser outlet temperature sensor

120/140/160 model - 220-240V~50Hz

Figure 2-4.2: 120/140/160 model piping diagram

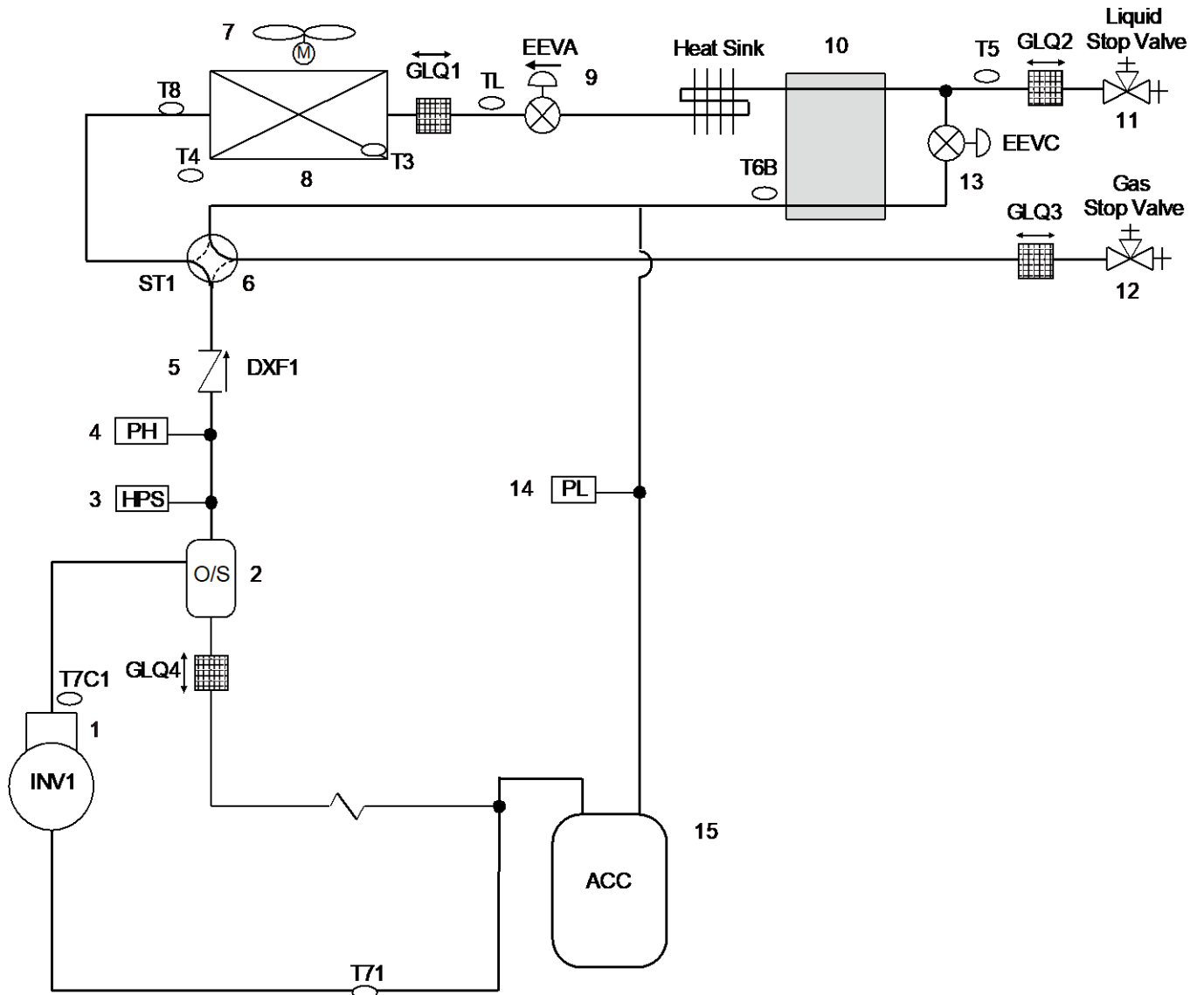

Legend		Legend	
No.	Parts name	No.	Parts name
1	Compressor	13	Electronic expansion valve (EEVC)
2	Oil separator	14	Low pressure sensor
3	High pressure switch	15	Gas-liquid separator
4	High pressure sensor		
5	Check valve	Sensor Code	Description
6	Four-way valve(ST1)	T3	Main heat exchanger pipe temperature sensor
7	Fan	T4	Outdoor ambient temperature sensor
8	Heat exchanger	T5	Liquid pipe temperature sensor
9	Electronic expansion valve (EEVA)	T6B	Plate heat exchanger outlet temperature sensor
10	Plate heat exchanger	T7C1	Compressor discharge temperature sensor
11	Stop valve (liquid side)	T71	Suction temperature sensor
12	Stop valve (gas side)	T8	Condenser inlet temperature sensor
		TL	Condenser outlet temperature sensor

4 Piping Diagrams

120/140/160 model - 380-415V 3N~50Hz

Figure 2-4.1: 120/140/160 model piping diagram

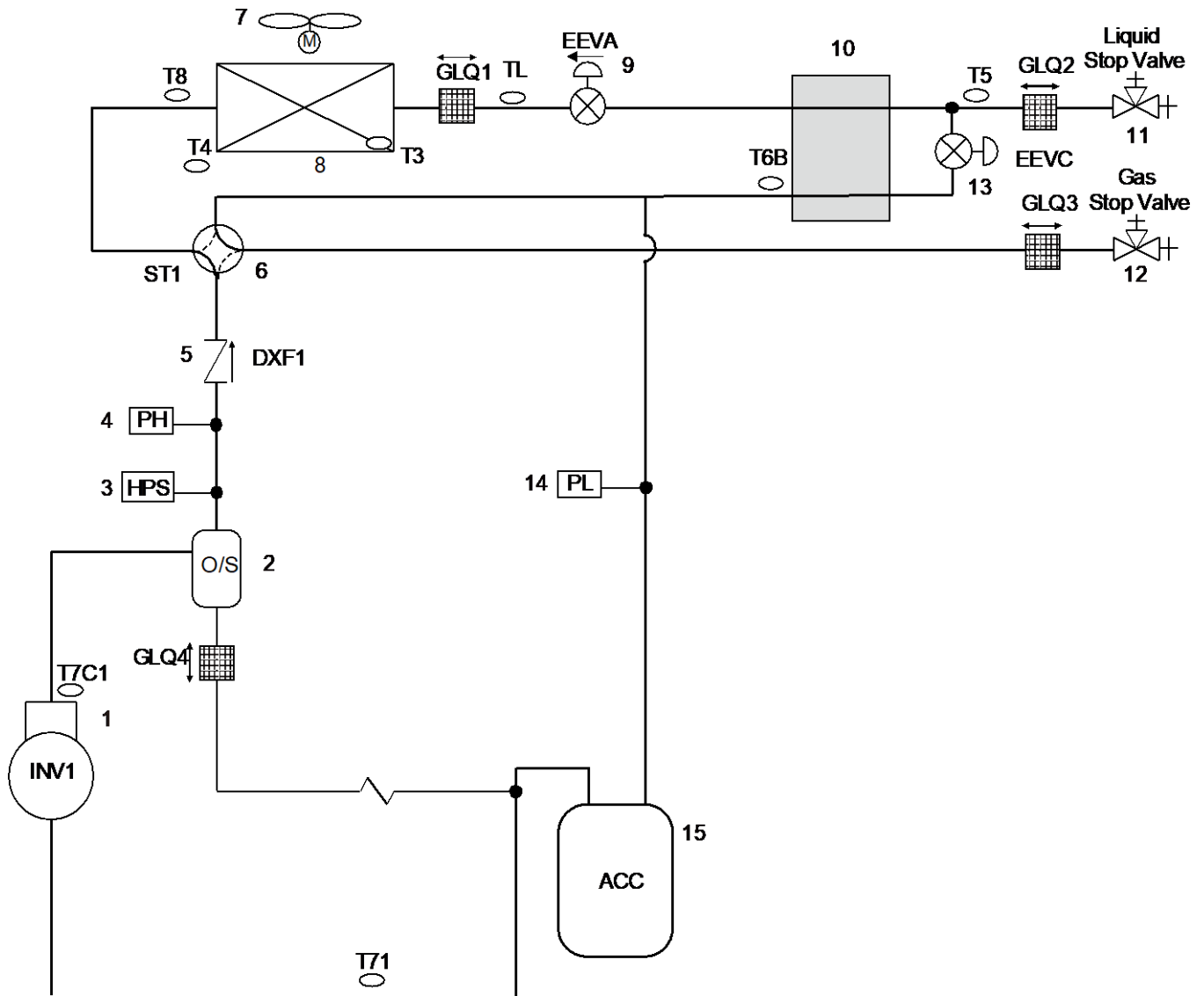

Legend			
No.	Parts name	No.	Parts name
1	Compressor	13	Electronic expansion valve (EEVC)
2	Oil separator	14	Low pressure sensor
3	High pressure switch	15	Gas-liquid separator
4	High pressure sensor		
5	Check value	Sensor Code	Description
6	Four-way valve(ST1)	T3	Main heat exchanger pipe temperature sensor
7	Fan	T4	Outdoor ambient temperature sensor
8	Heat exchanger	T5	Liquid pipe temperature sensor
9	Electronic expansion valve (EEVA)	T6B	Plate heat exchanger outlet temperature sensor
10	Plate heat exchanger	T7C1	Compressor discharge temperature sensor
11	Stop valve (liquid side)	T71	Suction temperature sensor
12	Stop valve (gas side)	T8	Condenser inlet temperature sensor
		TL	Condenser outlet temperature sensor

Key components:

1. **Oil separator:**
Separates oil from gas refrigerant pumped out of the compressor and quickly returns it to the compressor. Separation efficiency is up to 99%.
2. **Gas-liquid separator:**
Separates liquid refrigerant from gas refrigerant, stores liquid refrigerant and oil to protect compressor from liquid hammering.
3. **Electronic expansion valve (EEV):**
Controls refrigerant flow and reduces refrigerant pressure.
4. **Four-way valve(ST1):**
Controls heat exchanger function. When open, the heat exchanger functions as an evaporator; when closed, the heat exchanger functions as a condenser.
5. **Solenoid valve SV5:**
Controls the refrigerant from microchannel heat exchanger to gas-liquid separator.
6. **Solenoid valve SV6:**
Allows refrigerant to bypass the expansion valves. Opens in cooling mode when discharge temperature exceeds the limit. Closed in heating mode and standby.
7. **High pressure switch:**
Regulate system pressure. When system pressure rises above the upper limit, the high pressure switch turn off, stopping the compressor. When the high pressure protection recovers, the compressor restarts.
8. **High pressure sensor**
Used to detect the system high pressure.

5 Wiring Diagrams - 220-240V~50Hz

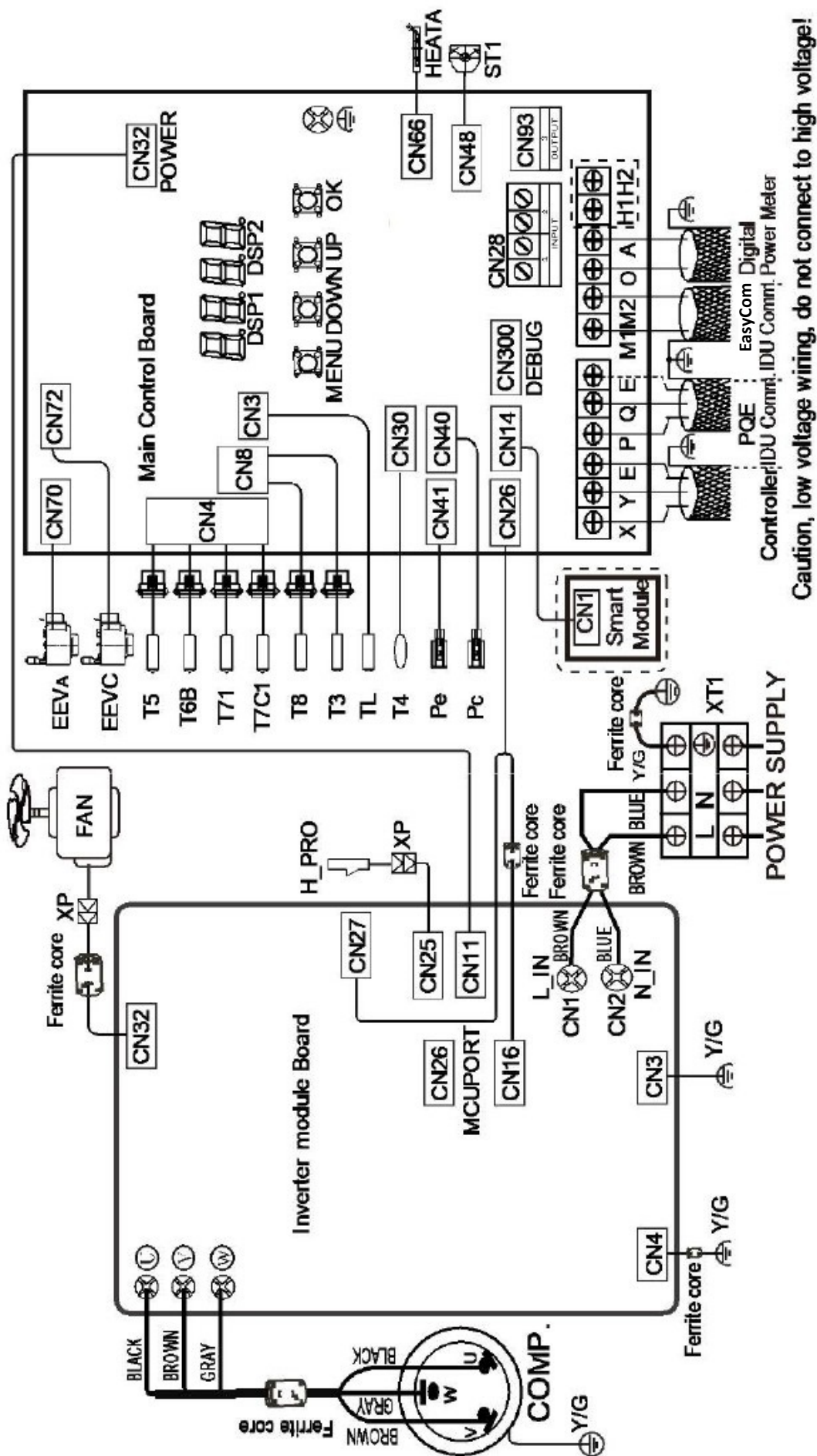

CN28 1: Dry input contact 1

CN28 2: Dry input contact 2

CN93 3: Dry output contact 3 via CN93

Auxiliary connector

5 Wiring Diagrams - 380-415V 3N~50Hz

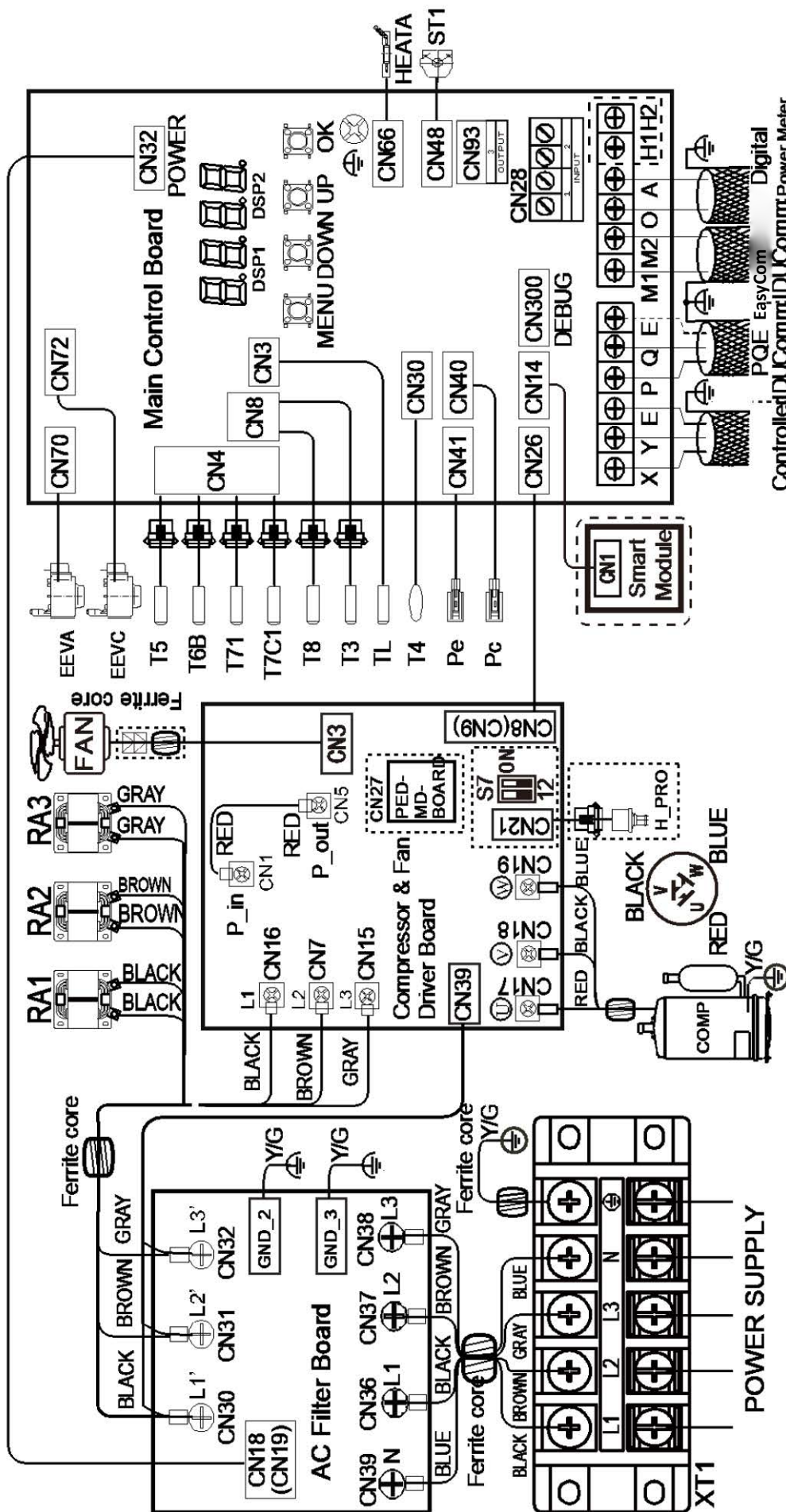

Caution, low voltage wiring, do not connect to high voltage!

- CN28 1: Dry input contact 1
- CN28 2: Dry input contact 2
- CN93 3: Dry output contact 3 via CN93 Auxiliary connector

Legend				
Code	Name		Code	Name
COMP	Compressor		T3	Main heat exchanger pipe temperature sensor
FAN	DC fan		T4	Outdoor ambient temperature sensor
H-PRO	High pressure switch		T5	Liquid pipe temperature sensor
HEAT A	Crankcase heater		T6B	Plate heat exchanger outlet temperature sensor
Pc	High pressure sensor		T71	Suction temperature sensor
Pe	Low pressure sensor		T7C1	Compressor discharge temperature sensor
ST1	Four-way valve		T8	Heat exchanger gas temperature sensor
XT1	Terminal block		TL	Heat exchanger liquid temperature sensor
EEVA/C	Electronic expansion valve		RA1/2/3	Reactor

6 Electrical Characteristics

Table 2-6.1: Outdoor unit electrical characteristics

Model name	Power Supply ¹							Compressor		Fan Motor	
	Hz	Volts	Min.	Max.	MCA ² (A)	TOCA ³ (A)	MFA ⁴ (A)	MSC ⁵ (A)	RLA ⁶ (A)	Power (kW)	FLA (A)
			volts	volts							
MSAN8-X 80M	50	220-240	198	264	21.3	18	25	/	15.9	0.2	1.0
MSAN8-X 100M	50	220-240	198	264	24	20	25	/	17.9	0.2	1.0
MSAN8-X 120M	50	220-240	198	264	32	27	32	/	24.8	0.2	1.2
MSAN8-X 140M	50	220-240	198	264	35	29	40	/	26.8	0.2	1.2
MSAN8-X 160M	50	220-240	198	264	40	33	40	/	30.3	0.2	1.2
MSAN8-X 120T	50	380-415	342	440	14	13	20	/	10.4	0.2	0.6
MSAN8-X 140T	50	380-415	342	440	15	14	20	/	11.4	0.2	0.6
MSAN8-X 160T	50	380-415	342	440	17	15	20	/	12.9	0.2	0.6

Abbreviations:

MCA: Minimum Circuit Amps; TOCA: Total Over-current Amps; MFA: Maximum Fuse Amps; MSC: Maximum Starting Current (A); RLA: Rated Load Amps; FLA: Full Load Amps

Notes:

1. Units are suitable for use on electrical systems where voltage supplied to unit terminals is not below or above listed range limits. For three phase units maximum allowable voltage variation between phases is 2%.
2. Select wire size based on the value of MCA.
3. TOCA indicates the total overcurrent amps value of each OC set.
4. MFA is used to select overcurrent circuit breakers and residual-current circuit breakers.
5. MSC indicates the maximum current on compressor start-up in amps.
6. RLA is based on the following conditions: indoor temperature 27°C DB, 19°C WB; outdoor temperature 35°C DB

7 Functional Components and Safety Devices

Table 2-7.1: 80/100/120/140/160 model functional components and safety devices

Item			80	100	120	140	160
Compressor	Discharge pipe temperature sensors		90°C = 5kΩ ± 3%				
	Crankcase heater		25W				
Fan motor	Safety thermostat	On	100°C				
		Off	80°C				
System	High pressure switch		Off: 4.3 (±0.1) MPa / On: 3.2 (±0.1) MPa				
	Heat exchanger temperature sensor		25°C = 10kΩ				
	Outdoor ambient temperature sensor		25°C = 10kΩ				

Table2-8.1:80 model cooling capacity - 220-240V~50Hz (continued)

CR	Outdoor air temp. (°CDB)	Indoor air temp. (°C DB/WD)													
		22/15		23.3/16		25.8/18		27/19		28.2/20		30.7/22		32/24	
		TC	PI	TC	PI	TC	PI	TC	PI	TC	PI	TC	PI	TC	PI
90%	-15	4.5	0.6	5.0	0.7	6.0	0.8	6.5	0.8	7.0	0.9	8.0	1.0	9.0	1.1
	-12	4.5	0.7	5.0	0.7	6.0	0.8	6.5	0.8	7.0	0.9	8.0	1.0	9.0	1.2
	-10	4.5	0.7	5.0	0.7	6.0	0.8	6.5	0.9	7.0	0.9	8.0	1.0	9.0	1.2
	-8	4.5	0.7	5.0	0.7	6.0	0.8	6.5	0.9	7.0	0.9	8.0	1.0	9.0	1.2
	-5	4.5	0.7	5.0	0.7	6.0	0.8	6.5	0.9	7.0	0.9	8.0	1.0	9.0	1.2
	-2	4.5	0.7	5.0	0.7	6.0	0.8	6.5	0.9	7.0	0.9	8.0	1.1	9.0	1.2
	0	4.5	0.7	5.0	0.8	6.0	0.9	6.5	0.9	7.0	1.0	8.0	1.1	9.0	1.2
	2	4.5	0.7	5.0	0.8	6.0	0.9	6.5	0.9	7.0	1.0	8.0	1.1	9.0	1.2
	4	4.5	0.8	5.0	0.8	6.0	0.9	6.5	0.9	7.0	1.0	8.0	1.1	9.0	1.2
	6	4.5	0.8	5.0	0.8	6.0	0.9	6.5	1.0	7.0	1.0	8.0	1.1	9.0	1.3
	8	4.5	0.8	5.0	0.8	6.0	1.0	6.5	1.0	7.0	1.1	8.0	1.2	9.0	1.3
	10	4.5	0.8	5.0	0.9	6.0	1.0	6.5	1.0	7.0	1.1	8.0	1.2	9.0	1.3
	12	4.5	0.9	5.0	0.9	6.0	1.0	6.5	1.1	7.0	1.1	8.0	1.3	9.0	1.4
	14	4.5	0.9	5.0	0.9	6.0	1.1	6.5	1.1	7.0	1.2	8.0	1.3	9.0	1.4
	16	4.5	0.9	5.0	1.0	6.0	1.1	6.5	1.2	7.0	1.2	8.0	1.3	9.0	1.5
	18	4.5	0.9	5.0	1.0	6.0	1.1	6.5	1.2	7.0	1.2	8.0	1.4	9.0	1.5
	20	4.5	1.0	5.0	1.0	6.0	1.2	6.5	1.2	7.0	1.3	8.0	1.4	9.0	1.6
	21	4.5	1.0	5.0	1.1	6.0	1.2	6.5	1.3	7.0	1.3	8.0	1.5	9.0	1.7
	23	4.5	1.1	5.0	1.1	6.0	1.2	6.5	1.3	7.0	1.4	8.0	1.5	9.0	1.8
	25	4.5	1.1	5.0	1.1	6.0	1.3	6.5	1.3	7.0	1.4	8.0	1.6	9.0	2.0
	27	4.5	1.1	5.0	1.2	6.0	1.3	6.5	1.4	7.0	1.5	8.0	1.8	9.0	2.2
	29	4.5	1.1	5.0	1.2	6.0	1.4	6.5	1.5	7.0	1.7	8.0	1.9	9.0	2.3
31	4.5	1.2	5.0	1.3	6.0	1.5	6.5	1.7	7.0	1.8	8.0	2.1	9.0	2.5	
33	4.5	1.2	5.0	1.4	6.0	1.6	6.5	1.8	7.0	1.9	8.0	2.3	9.0	2.7	
35	4.5	1.3	5.0	1.5	6.0	1.8	6.5	1.9	7.0	2.1	8.0	2.4	9.0	3.0	
37	4.5	1.4	5.0	1.6	6.0	1.9	6.5	2.1	7.0	2.3	8.0	2.6	9.0	3.2	
39	4.5	1.5	5.0	1.7	6.0	2.0	6.5	2.2	7.0	2.4	8.0	2.8	9.0	3.4	
41	4.5	1.7	5.0	1.8	6.0	2.2	6.5	2.4	7.0	2.6	8.0	3.0	9.0	3.7	
43	4.5	1.8	5.0	2.0	6.0	2.4	6.5	2.6	7.0	2.8	8.0	3.3	9.0	4.0	
45	4.5	1.9	5.0	2.1	6.0	2.5	6.5	2.8	7.0	3.0	8.0	3.5	9.0	4.3	
48	4.5	2.1	5.0	2.4	6.0	2.8	6.5	3.1	7.0	3.4	7.7	3.7	7.8	3.7	
50	4.5	2.3	5.0	2.5	6.0	3.1	6.2	3.1	6.5	3.2	6.6	3.1	6.7	3.0	
52	4.3	2.3	4.6	2.5	5.2	2.7	5.3	2.7	5.4	2.7	5.6	2.6	5.6	2.5	
80%	-15	4.0	0.6	4.4	0.6	5.3	0.7	5.8	0.7	6.2	0.8	7.1	0.9	8.0	1.0
	-12	4.0	0.6	4.4	0.6	5.3	0.7	5.8	0.7	6.2	0.8	7.1	0.9	8.0	1.0
	-10	4.0	0.6	4.4	0.6	5.3	0.7	5.8	0.8	6.2	0.8	7.1	0.9	8.0	1.0
	-8	4.0	0.6	4.4	0.6	5.3	0.7	5.8	0.8	6.2	0.8	7.1	0.9	8.0	1.0
	-5	4.0	0.6	4.4	0.7	5.3	0.7	5.8	0.8	6.2	0.8	7.1	0.9	8.0	1.0
	-2	4.0	0.7	4.4	0.7	5.3	0.7	5.8	0.8	6.2	0.8	7.1	0.9	8.0	1.0
	0	4.0	0.7	4.4	0.7	5.3	0.8	5.8	0.8	6.2	0.9	7.1	1.0	8.0	1.1
	2	4.0	0.7	4.4	0.7	5.3	0.8	5.8	0.8	6.2	0.9	7.1	1.0	8.0	1.1
	4	4.0	0.7	4.4	0.8	5.3	0.8	5.8	0.9	6.2	0.9	7.1	1.0	8.0	1.1
	6	4.0	0.7	4.4	0.8	5.3	0.9	5.8	0.9	6.2	0.9	7.1	1.0	8.0	1.1
	8	4.0	0.8	4.4	0.8	5.3	0.9	5.8	0.9	6.2	1.0	7.1	1.1	8.0	1.1
	10	4.0	0.8	4.4	0.8	5.3	0.9	5.8	1.0	6.2	1.0	7.1	1.1	8.0	1.2
	12	4.0	0.8	4.4	0.8	5.3	0.9	5.8	1.0	6.2	1.0	7.1	1.1	8.0	1.2
	14	4.0	0.8	4.4	0.9	5.3	1.0	5.8	1.0	6.2	1.0	7.1	1.2	8.0	1.3
	16	4.0	0.8	4.4	0.9	5.3	1.0	5.8	1.0	6.2	1.1	7.1	1.2	8.0	1.3
	18	4.0	0.9	4.4	0.9	5.3	1.0	5.8	1.1	6.2	1.1	7.1	1.3	8.0	1.3
	20	4.0	0.9	4.4	0.9	5.3	1.0	5.8	1.1	6.2	1.2	7.1	1.3	8.0	1.4
	21	4.0	0.9	4.4	1.0	5.3	1.1	5.8	1.1	6.2	1.2	7.1	1.3	8.0	1.4
	23	4.0	1.0	4.4	1.0	5.3	1.1	5.8	1.2	6.2	1.2	7.1	1.3	8.0	1.5
	25	4.0	1.0	4.4	1.0	5.3	1.1	5.8	1.2	6.2	1.3	7.1	1.4	8.0	1.7
	27	4.0	1.0	4.4	1.0	5.3	1.2	5.8	1.2	6.2	1.3	7.1	1.5	8.0	1.8
	29	4.0	1.0	4.4	1.1	5.3	1.2	5.8	1.3	6.2	1.4	7.1	1.6	8.0	2.0
31	4.0	1.0	4.4	1.1	5.3	1.3	5.8	1.4	6.2	1.5	7.1	1.8	8.0	2.1	
33	4.0	1.1	4.4	1.2	5.3	1.4	5.8	1.5	6.2	1.7	7.1	1.9	8.0	2.3	
35	4.0	1.2	4.4	1.3	5.3	1.5	5.8	1.7	6.2	1.8	7.1	2.1	8.0	2.5	
37	4.0	1.3	4.4	1.4	5.3	1.6	5.8	1.8	6.2	1.9	7.1	2.2	8.0	2.7	
39	4.0	1.4	4.4	1.5	5.3	1.8	5.8	1.9	6.2	2.1	7.1	2.4	8.0	2.9	
41	4.0	1.5	4.4	1.6	5.3	1.9	5.8	2.1	6.2	2.2	7.1	2.6	8.0	3.1	
43	4.0	1.6	4.4	1.7	5.3	2.1	5.8	2.2	6.2	2.4	7.1	2.8	8.0	3.3	
45	4.0	1.7	4.4	1.9	5.3	2.2	5.8	2.4	6.2	2.6	7.1	3.0	8.0	3.6	
48	4.0	1.9	4.4	2.1	5.3	2.5	5.8	2.7	6.2	2.9	7.1	3.3	7.6	3.7	
50	4.0	2.0	4.4	2.2	5.3	2.7	5.8	2.9	6.2	3.1	6.6	3.2	6.6	3.1	
52	4.0	2.2	4.3	2.3	4.9	2.6	5.2	2.7	5.3	2.7	5.5	2.6	5.6	2.5	

Abbreviations:

CR: Combination ratio

TC: Total capacity (kW)

PI: Power input (compressor + outdoor fan motor) (kW)

Notes:

Shaded cells indicate rating condition.

Table continued on next page ...

Table2-8.1:80 model cooling capacity - 220-240V~50Hz (continued)

CR	Outdoor air temp. (°CDB)	Indoor air temp. (°C DB/WD)													
		22/15		23.3/16		25.8/18		27/19		28.2/20		30.7/22		32/24	
		TC	PI	TC	PI	TC	PI	TC	PI	TC	PI	TC	PI	TC	PI
50%	-15	2.5	0.4	2.8	0.5	3.3	0.5	3.6	0.5	3.9	0.5	4.4	0.6	5.0	0.6
	-12	2.5	0.5	2.8	0.5	3.3	0.5	3.6	0.5	3.9	0.5	4.4	0.6	5.0	0.6
	-10	2.5	0.5	2.8	0.5	3.3	0.5	3.6	0.5	3.9	0.6	4.4	0.6	5.0	0.6
	-8	2.5	0.5	2.8	0.5	3.3	0.5	3.6	0.5	3.9	0.6	4.4	0.6	5.0	0.6
	-5	2.5	0.5	2.8	0.5	3.3	0.5	3.6	0.5	3.9	0.6	4.4	0.6	5.0	0.6
	-2	2.5	0.5	2.8	0.5	3.3	0.6	3.6	0.6	3.9	0.6	4.4	0.7	5.0	0.7
	0	2.5	0.5	2.8	0.5	3.3	0.6	3.6	0.6	3.9	0.6	4.4	0.7	5.0	0.7
	2	2.5	0.5	2.8	0.5	3.3	0.6	3.6	0.6	3.9	0.6	4.4	0.7	5.0	0.7
	4	2.5	0.5	2.8	0.5	3.3	0.6	3.6	0.6	3.9	0.7	4.4	0.7	5.0	0.8
	6	2.5	0.5	2.8	0.6	3.3	0.6	3.6	0.7	3.9	0.7	4.4	0.7	5.0	0.8
	8	2.5	0.6	2.8	0.6	3.3	0.6	3.6	0.7	3.9	0.7	4.4	0.7	5.0	0.8
	10	2.5	0.6	2.8	0.6	3.3	0.7	3.6	0.7	3.9	0.7	4.4	0.7	5.0	0.8
	12	2.5	0.6	2.8	0.6	3.3	0.7	3.6	0.7	3.9	0.7	4.4	0.8	5.0	0.8
	14	2.5	0.6	2.8	0.6	3.3	0.7	3.6	0.7	3.9	0.7	4.4	0.8	5.0	0.8
	16	2.5	0.6	2.8	0.6	3.3	0.7	3.6	0.7	3.9	0.7	4.4	0.8	5.0	0.9
	18	2.5	0.7	2.8	0.7	3.3	0.7	3.6	0.7	3.9	0.8	4.4	0.8	5.0	0.9
	20	2.5	0.7	2.8	0.7	3.3	0.7	3.6	0.8	3.9	0.8	4.4	0.8	5.0	0.9
	21	2.5	0.7	2.8	0.7	3.3	0.7	3.6	0.8	3.9	0.8	4.4	0.9	5.0	0.9
	23	2.5	0.7	2.8	0.7	3.3	0.8	3.6	0.8	3.9	0.8	4.4	0.9	5.0	0.9
	25	2.5	0.7	2.8	0.7	3.3	0.8	3.6	0.8	3.9	0.8	4.4	0.9	5.0	1.0
27	2.5	0.7	2.8	0.7	3.3	0.8	3.6	0.8	3.9	0.9	4.4	0.9	5.0	1.0	
29	2.5	0.7	2.8	0.8	3.3	0.8	3.6	0.8	3.9	0.9	4.4	0.9	5.0	1.1	
31	2.5	0.8	2.8	0.8	3.3	0.9	3.6	0.9	3.9	0.9	4.4	1.0	5.0	1.2	
33	2.5	0.8	2.8	0.9	3.3	0.9	3.6	1.0	3.9	1.0	4.4	1.1	5.0	1.3	
35	2.5	0.9	2.8	0.9	3.3	1.0	3.6	1.0	3.9	1.1	4.4	1.2	5.0	1.4	
37	2.5	0.9	2.8	1.0	3.3	1.1	3.6	1.1	3.9	1.1	4.4	1.3	5.0	1.5	
39	2.5	1.0	2.8	1.0	3.3	1.1	3.6	1.2	3.9	1.2	4.4	1.4	5.0	1.6	
41	2.5	1.1	2.8	1.1	3.3	1.2	3.6	1.3	3.9	1.3	4.4	1.5	5.0	1.7	
43	2.5	1.1	2.8	1.2	3.3	1.3	3.6	1.3	3.9	1.4	4.4	1.6	5.0	1.8	
45	2.5	1.2	2.8	1.2	3.3	1.4	3.6	1.4	3.9	1.5	4.4	1.7	5.0	2.0	
48	2.5	1.3	2.8	1.4	3.3	1.5	3.6	1.6	3.9	1.7	4.4	1.9	5.0	2.2	
50	2.5	1.4	2.8	1.5	3.3	1.6	3.6	1.7	3.9	1.8	4.4	2.1	5.0	2.4	
52	2.1	1.3	2.8	1.6	3.3	1.7	3.6	1.9	3.9	2.0	4.4	2.2	4.8	2.5	

Abbreviations:

CR: Combination ratio

TC: Total capacity (kW)

PI: Power input (compressor + outdoor fan motor) (kW)

Notes:

Shaded cells indicate rating condition.

Table 2-8.2: 100 model cooling capacity - 220-240V~50Hz (continued)

CR	Outdoor air temp. (°CDB)	Indoor air temp. (°C DB/WD)													
		22/15		23.3/16		25.8/18		27/19		28.2/20		30.7/22		32/24	
		TC	PI	TC	PI	TC	PI	TC	PI	TC	PI	TC	PI	TC	PI
110%	-15	6.9	0.9	7.6	1.0	9.1	1.1	9.9	1.2	10.7	1.3	12.2	1.5	13.7	2.0
	-12	6.9	0.9	7.6	1.0	9.1	1.2	9.9	1.3	10.7	1.4	12.2	1.6	13.7	2.1
	-10	6.9	0.9	7.6	1.0	9.1	1.2	9.9	1.3	10.7	1.4	12.2	1.7	13.7	2.1
	-8	6.9	1.0	7.6	1.0	9.1	1.2	9.9	1.3	10.7	1.4	12.2	1.7	13.7	2.1
	-5	6.9	1.0	7.6	1.0	9.1	1.2	9.9	1.3	10.7	1.4	12.2	1.8	13.7	2.1
	-2	6.9	1.0	7.6	1.0	9.1	1.2	9.9	1.3	10.7	1.5	12.2	1.8	13.7	2.2
	0	6.9	1.0	7.6	1.1	9.1	1.2	9.9	1.3	10.7	1.5	12.2	1.8	13.7	2.2
	2	6.9	1.0	7.6	1.1	9.1	1.2	9.9	1.4	10.7	1.5	12.2	1.8	13.7	2.2
	4	6.9	1.0	7.6	1.1	9.1	1.3	9.9	1.4	10.7	1.5	12.2	1.8	13.7	2.2
	6	6.9	1.0	7.6	1.1	9.1	1.3	9.9	1.4	10.7	1.6	12.2	1.9	13.7	2.2
	8	6.9	1.1	7.6	1.2	9.1	1.3	9.9	1.4	10.7	1.6	12.2	1.9	13.7	2.3
	10	6.9	1.1	7.6	1.2	9.1	1.3	9.9	1.4	10.7	1.6	12.2	1.9	13.7	2.4
	12	6.9	1.1	7.6	1.2	9.1	1.4	9.9	1.5	10.7	1.6	12.2	2.0	13.4	2.6
	14	6.9	1.1	7.6	1.2	9.1	1.4	9.9	1.5	10.7	1.7	12.2	2.2	13.3	2.7
	16	6.9	1.2	7.6	1.2	9.1	1.4	9.9	1.6	10.7	1.9	12.2	2.3	13.1	2.8
	18	6.9	1.2	7.6	1.3	9.1	1.6	9.9	1.8	10.7	2.0	12.2	2.5	13.0	3.0
	20	6.9	1.2	7.6	1.4	9.1	1.7	9.9	1.9	10.7	2.2	12.2	2.7	12.8	3.1
	21	6.9	1.3	7.6	1.4	9.1	1.8	9.9	2.0	10.7	2.3	12.2	2.9	12.8	3.2
	23	6.9	1.4	7.6	1.5	9.1	1.9	9.9	2.2	10.7	2.5	12.2	3.1	12.6	3.3
	25	6.9	1.5	7.6	1.6	9.1	2.1	9.9	2.4	10.7	2.7	12.2	3.3	12.5	3.4
	27	6.9	1.6	7.6	1.8	9.1	2.3	9.9	2.5	10.7	2.9	12.2	3.6	12.3	3.6
	29	6.9	1.7	7.6	1.9	9.1	2.4	9.9	2.7	10.7	3.1	11.9	3.7	12.1	3.7
	31	6.9	1.8	7.6	2.0	9.1	2.6	9.9	2.9	10.7	3.3	11.7	3.8	12.0	3.8
	33	6.9	1.9	7.6	2.2	9.1	2.8	9.9	3.1	10.7	3.5	11.5	4.0	11.8	4.0
	35	6.9	2.1	7.6	2.3	9.1	3.0	9.9	3.4	10.7	3.8	11.4	4.1	11.6	4.2
	37	6.9	2.2	7.6	2.5	9.1	3.2	9.9	3.6	10.7	4.1	11.2	4.3	11.5	4.3
39	6.9	2.4	7.6	2.7	9.1	3.5	9.9	3.9	10.7	4.4	11.0	4.4	11.2	4.4	
41	6.9	2.6	7.6	2.9	9.1	3.7	9.9	4.2	10.2	4.4	10.6	4.4	10.8	4.4	
43	6.9	2.7	7.6	3.1	9.1	4.0	9.3	4.1	9.6	4.2	10.2	4.3	10.5	4.4	
45	6.9	2.9	7.6	3.3	8.4	3.7	8.7	3.8	9.0	3.9	9.5	4.0	9.6	3.9	
48	6.5	3.0	6.8	3.1	7.4	3.3	7.7	3.4	7.7	3.3	8.0	3.2	8.0	3.1	
50	5.7	2.7	6.0	2.8	6.5	2.9	6.6	2.8	6.7	2.8	6.8	2.6	6.9	2.6	
52	4.9	2.4	5.3	2.6	5.3	2.4	5.5	2.4	5.5	2.3	5.7	2.2	5.5	2.1	
100%	-15	6.2	0.8	6.9	0.9	8.3	1.0	9.0	1.1	9.7	1.2	11.1	1.4	12.5	1.7
	-12	6.2	0.8	6.9	0.9	8.3	1.1	9.0	1.1	9.7	1.2	11.1	1.4	12.5	1.8
	-10	6.2	0.8	6.9	0.9	8.3	1.1	9.0	1.2	9.7	1.2	11.1	1.4	12.5	1.8
	-8	6.2	0.9	6.9	0.9	8.3	1.1	9.0	1.2	9.7	1.2	11.1	1.5	12.5	1.8
	-5	6.2	0.9	6.9	0.9	8.3	1.1	9.0	1.2	9.7	1.3	11.1	1.5	12.5	1.8
	-2	6.2	0.9	6.9	1.0	8.3	1.1	9.0	1.2	9.7	1.3	11.1	1.5	12.5	1.8
	0	6.2	0.9	6.9	1.0	8.3	1.1	9.0	1.2	9.7	1.3	11.1	1.6	12.5	1.9
	2	6.2	0.9	6.9	1.0	8.3	1.2	9.0	1.3	9.7	1.4	11.1	1.6	12.5	2.0
	4	6.2	0.9	6.9	1.0	8.3	1.2	9.0	1.3	9.7	1.4	11.1	1.6	12.5	2.0
	6	6.2	0.9	6.9	1.0	8.3	1.2	9.0	1.3	9.7	1.4	11.1	1.6	12.5	2.0
	8	6.2	1.0	6.9	1.0	8.3	1.2	9.0	1.3	9.7	1.4	11.1	1.6	12.5	2.0
	10	6.2	1.0	6.9	1.1	8.3	1.2	9.0	1.3	9.7	1.4	11.1	1.6	12.5	2.1
	12	6.2	1.0	6.9	1.1	8.3	1.3	9.0	1.3	9.7	1.4	11.1	1.7	12.5	2.2
	14	6.2	1.1	6.9	1.1	8.3	1.3	9.0	1.4	9.7	1.5	11.1	1.8	12.5	2.3
	16	6.2	1.1	6.9	1.2	8.3	1.3	9.0	1.4	9.7	1.6	11.1	1.9	12.5	2.5
	18	6.2	1.1	6.9	1.2	8.3	1.4	9.0	1.5	9.7	1.7	11.1	2.1	12.5	2.7
	20	6.2	1.1	6.9	1.2	8.3	1.5	9.0	1.6	9.7	1.9	11.1	2.3	12.5	3.0
	21	6.2	1.2	6.9	1.2	8.3	1.5	9.0	1.7	9.7	1.9	11.1	2.4	12.5	3.1
	23	6.2	1.2	6.9	1.3	8.3	1.7	9.0	1.9	9.7	2.1	11.1	2.6	12.5	3.3
	25	6.2	1.3	6.9	1.4	8.3	1.8	9.0	2.0	9.7	2.3	11.1	2.8	12.1	3.4
	27	6.2	1.4	6.9	1.6	8.3	1.9	9.0	2.2	9.7	2.4	11.1	3.0	11.9	3.5
	29	6.2	1.5	6.9	1.7	8.3	2.1	9.0	2.3	9.7	2.6	11.1	3.2	11.8	3.6
	31	6.2	1.6	6.9	1.8	8.3	2.2	9.0	2.5	9.7	2.8	11.1	3.4	11.6	3.8
	33	6.2	1.7	6.9	1.9	8.3	2.4	9.0	2.7	9.7	3.0	11.1	3.7	11.5	3.9
	35	6.2	1.8	6.9	2.1	8.3	2.6	9.0	2.9	9.7	3.2	11.1	4.0	11.3	4.1
	37	6.2	2.0	6.9	2.2	8.3	2.8	9.0	3.1	9.7	3.5	11.1	4.3	11.1	4.3
39	6.2	2.1	6.9	2.4	8.3	3.0	9.0	3.3	9.7	3.7	10.7	4.4	10.9	4.4	
41	6.2	2.3	6.9	2.5	8.3	3.2	9.0	3.6	9.7	4.0	10.4	4.4	10.6	4.4	
43	6.2	2.4	6.9	2.7	8.3	3.4	9.0	3.9	9.3	4.1	9.9	4.2	10.1	4.3	
45	6.2	2.6	6.9	2.9	8.1	3.6	8.4	3.7	8.7	3.8	9.2	4.0	9.5	4.0	
48	6.2	2.9	6.6	3.0	7.2	3.2	7.4	3.3	7.7	3.3	7.9	3.2	7.9	3.1	
50	5.5	2.6	5.8	2.7	6.5	2.9	6.5	2.9	6.7	2.9	6.7	2.7	6.8	2.6	
52	4.7	2.3	5.0	2.4	5.3	2.4	5.5	2.4	5.5	2.4	5.6	2.2	5.7	2.2	

Abbreviations:
 CR: Combination ratio
 TC: Total capacity (kW)
 PI: Power input (compressor + outdoor fan motor) (kW)
 Notes:
 Shaded cells indicate rating condition.

Table continued on next page ...

Table2-8.2:100 model cooling capacity - 220-240V~50Hz (continued)

CR	Outdoor air temp. (°CDB)	Indoor air temp. (°C DB/WD)													
		22/15		23.3/16		25.8/18		27/19		28.2/20		30.7/22		32/24	
		TC	PI	TC	PI	TC	PI	TC	PI	TC	PI	TC	PI	TC	PI
90%	-15	5.6	0.7	6.2	0.8	7.5	0.9	8.1	1.0	8.7	1.0	10.0	1.2	11.2	1.3
	-12	5.6	0.7	6.2	0.8	7.5	0.9	8.1	1.0	8.7	1.1	10.0	1.2	11.2	1.4
	-10	5.6	0.8	6.2	0.8	7.5	1.0	8.1	1.0	8.7	1.1	10.0	1.2	11.2	1.5
	-8	5.6	0.8	6.2	0.9	7.5	1.0	8.1	1.1	8.7	1.1	10.0	1.3	11.2	1.5
	-5	5.6	0.8	6.2	0.9	7.5	1.0	8.1	1.1	8.7	1.1	10.0	1.3	11.2	1.5
	-2	5.6	0.8	6.2	0.9	7.5	1.0	8.1	1.1	8.7	1.2	10.0	1.3	11.2	1.6
	0	5.6	0.8	6.2	0.9	7.5	1.0	8.1	1.1	8.7	1.2	10.0	1.3	11.2	1.6
	2	5.6	0.8	6.2	0.9	7.5	1.0	8.1	1.1	8.7	1.2	10.0	1.3	11.2	1.7
	4	5.6	0.8	6.2	0.9	7.5	1.0	8.1	1.1	8.7	1.2	10.0	1.3	11.2	1.7
	6	5.6	0.9	6.2	0.9	7.5	1.1	8.1	1.1	8.7	1.2	10.0	1.3	11.2	1.7
	8	5.6	0.9	6.2	0.9	7.5	1.1	8.1	1.2	8.7	1.2	10.0	1.4	11.2	1.7
	10	5.6	0.9	6.2	0.9	7.5	1.1	8.1	1.2	8.7	1.2	10.0	1.4	11.2	1.8
	12	5.6	0.9	6.2	1.0	7.5	1.1	8.1	1.2	8.7	1.2	10.0	1.4	11.2	1.8
	14	5.6	1.0	6.2	1.0	7.5	1.2	8.1	1.2	8.7	1.3	10.0	1.5	11.2	1.9
	16	5.6	1.0	6.2	1.1	7.5	1.2	8.1	1.3	8.7	1.3	10.0	1.6	11.2	2.1
	18	5.6	1.0	6.2	1.1	7.5	1.2	8.1	1.3	8.7	1.4	10.0	1.7	11.2	2.2
	20	5.6	1.0	6.2	1.1	7.5	1.3	8.1	1.4	8.7	1.5	10.0	1.9	11.2	2.4
	21	5.6	1.1	6.2	1.1	7.5	1.3	8.1	1.5	8.7	1.6	10.0	2.0	11.2	2.5
	23	5.6	1.1	6.2	1.2	7.5	1.4	8.1	1.6	8.7	1.7	10.0	2.1	11.2	2.7
	25	5.6	1.1	6.2	1.3	7.5	1.5	8.1	1.7	8.7	1.9	10.0	2.3	11.2	2.9
	27	5.6	1.2	6.2	1.4	7.5	1.7	8.1	1.8	8.7	2.0	10.0	2.5	11.2	3.1
	29	5.6	1.3	6.2	1.5	7.5	1.8	8.1	2.0	8.7	2.2	10.0	2.7	11.2	3.4
	31	5.6	1.4	6.2	1.6	7.5	1.9	8.1	2.1	8.7	2.4	10.0	2.9	11.2	3.6
33	5.6	1.5	6.2	1.7	7.5	2.1	8.1	2.3	8.7	2.5	10.0	3.1	11.2	3.9	
35	5.6	1.6	6.2	1.8	7.5	2.2	8.1	2.5	8.7	2.7	10.0	3.3	10.9	4.0	
37	5.6	1.7	6.2	1.9	7.5	2.4	8.1	2.7	8.7	2.9	10.0	3.6	10.8	4.2	
39	5.6	1.9	6.2	2.1	7.5	2.6	8.1	2.8	8.7	3.2	10.0	3.8	10.6	4.4	
41	5.6	2.0	6.2	2.2	7.5	2.7	8.1	3.1	8.7	3.4	10.0	4.2	10.3	4.4	
43	5.6	2.1	6.2	2.4	7.5	3.0	8.1	3.3	8.7	3.6	9.5	4.1	9.8	4.2	
45	5.6	2.3	6.2	2.6	7.5	3.2	8.1	3.5	8.3	3.6	8.9	3.8	9.1	3.9	
48	5.6	2.5	6.2	2.8	6.9	3.1	7.1	3.2	7.4	3.3	7.8	3.2	7.9	3.2	
50	5.2	2.5	5.6	2.6	6.2	2.8	6.5	2.9	6.5	2.8	6.7	2.8	6.8	2.7	
52	4.4	2.2	4.8	2.3	5.3	2.4	5.4	2.4	5.5	2.4	5.5	2.2	5.6	2.2	
80%	-15	5.0	0.6	5.5	0.7	6.6	0.8	7.2	0.8	7.8	0.9	8.9	1.1	10.0	1.2
	-12	5.0	0.6	5.5	0.7	6.6	0.8	7.2	0.9	7.8	0.9	8.9	1.1	10.0	1.2
	-10	5.0	0.7	5.5	0.7	6.6	0.9	7.2	0.9	7.8	1.0	8.9	1.1	10.0	1.3
	-8	5.0	0.7	5.5	0.8	6.6	0.9	7.2	0.9	7.8	1.0	8.9	1.1	10.0	1.3
	-5	5.0	0.7	5.5	0.8	6.6	0.9	7.2	0.9	7.8	1.0	8.9	1.1	10.0	1.3
	-2	5.0	0.7	5.5	0.8	6.6	0.9	7.2	0.9	7.8	1.0	8.9	1.2	10.0	1.3
	0	5.0	0.7	5.5	0.8	6.6	0.9	7.2	0.9	7.8	1.0	8.9	1.2	10.0	1.3
	2	5.0	0.7	5.5	0.8	6.6	0.9	7.2	1.0	7.8	1.0	8.9	1.2	10.0	1.3
	4	5.0	0.7	5.5	0.8	6.6	0.9	7.2	1.0	7.8	1.0	8.9	1.2	10.0	1.3
	6	5.0	0.8	5.5	0.8	6.6	0.9	7.2	1.0	7.8	1.1	8.9	1.2	10.0	1.4
	8	5.0	0.8	5.5	0.8	6.6	1.0	7.2	1.0	7.8	1.1	8.9	1.2	10.0	1.4
	10	5.0	0.8	5.5	0.9	6.6	1.0	7.2	1.0	7.8	1.1	8.9	1.2	10.0	1.4
	12	5.0	0.8	5.5	0.9	6.6	1.0	7.2	1.1	7.8	1.1	8.9	1.2	10.0	1.5
	14	5.0	0.9	5.5	0.9	6.6	1.0	7.2	1.1	7.8	1.2	8.9	1.3	10.0	1.5
	16	5.0	0.9	5.5	0.9	6.6	1.1	7.2	1.1	7.8	1.2	8.9	1.3	10.0	1.6
	18	5.0	0.9	5.5	1.0	6.6	1.1	7.2	1.2	7.8	1.2	8.9	1.4	10.0	1.8
	20	5.0	0.9	5.5	1.0	6.6	1.1	7.2	1.2	7.8	1.3	8.9	1.5	10.0	2.0
	21	5.0	1.0	5.5	1.0	6.6	1.1	7.2	1.2	7.8	1.3	8.9	1.6	10.0	2.0
	23	5.0	1.0	5.5	1.1	6.6	1.2	7.2	1.3	7.8	1.5	8.9	1.7	10.0	2.2
	25	5.0	1.0	5.5	1.1	6.6	1.3	7.2	1.4	7.8	1.6	8.9	1.9	10.0	2.4
	27	5.0	1.1	5.5	1.2	6.6	1.4	7.2	1.6	7.8	1.7	8.9	2.0	10.0	2.6
	29	5.0	1.1	5.5	1.3	6.6	1.5	7.2	1.7	7.8	1.8	8.9	2.2	10.0	2.7
	31	5.0	1.2	5.5	1.4	6.6	1.6	7.2	1.8	7.8	2.0	8.9	2.4	10.0	2.9
33	5.0	1.3	5.5	1.5	6.6	1.8	7.2	1.9	7.8	2.1	8.9	2.5	10.0	3.2	
35	5.0	1.4	5.5	1.6	6.6	1.9	7.2	2.1	7.8	2.3	8.9	2.7	10.0	3.4	
37	5.0	1.5	5.5	1.7	6.6	2.0	7.2	2.2	7.8	2.5	8.9	2.9	10.0	3.7	
39	5.0	1.6	5.5	1.8	6.6	2.2	7.2	2.4	7.8	2.6	8.9	3.2	10.0	3.9	
41	5.0	1.7	5.5	1.9	6.6	2.3	7.2	2.6	7.8	2.8	8.9	3.4	10.0	4.3	
43	5.0	1.9	5.5	2.1	6.6	2.5	7.2	2.8	7.8	3.1	8.9	3.7	9.3	4.0	
45	5.0	2.0	5.5	2.2	6.6	2.7	7.2	3.0	7.8	3.3	8.5	3.7	8.7	3.8	
48	5.0	2.2	5.5	2.5	6.6	3.0	6.8	3.1	7.1	3.1	7.6	3.3	7.8	3.3	
50	5.0	2.4	5.3	2.5	5.9	2.7	6.1	2.8	6.4	2.9	6.6	2.8	6.7	2.7	
52	4.2	2.1	4.5	2.2	5.1	2.4	5.3	2.4	5.4	2.4	5.4	2.2	5.6	2.2	

Abbreviations:

CR: Combination ratio

TC: Total capacity (kW)

PI: Power input (compressor + outdoor fan motor) (kW)

Notes:

Shaded cells indicate rating condition.

Table continued on next page ...

Table2-8.2:100 model cooling capacity - 220-240V~50Hz (continued)

CR	Outdoor air temp. (°CDB)	Indoor air temp. (°C DB/WD)													
		22/15		23.3/16		25.8/18		27/19		28.2/20		30.7/22		32/24	
		TC	PI	TC	PI	TC	PI	TC	PI	TC	PI	TC	PI	TC	PI
50%	-15	3.1	0.5	3.5	0.5	4.2	0.5	4.5	0.5	4.8	0.6	5.5	0.6	6.2	0.7
	-12	3.1	0.5	3.5	0.5	4.2	0.5	4.5	0.5	4.8	0.6	5.5	0.6	6.2	0.7
	-10	3.1	0.5	3.5	0.5	4.2	0.5	4.5	0.6	4.8	0.6	5.5	0.7	6.2	0.7
	-8	3.1	0.5	3.5	0.5	4.2	0.5	4.5	0.6	4.8	0.6	5.5	0.7	6.2	0.8
	-5	3.1	0.5	3.5	0.5	4.2	0.6	4.5	0.6	4.8	0.6	5.5	0.7	6.2	0.8
	-2	3.1	0.5	3.5	0.5	4.2	0.6	4.5	0.6	4.8	0.6	5.5	0.7	6.2	0.8
	0	3.1	0.5	3.5	0.5	4.2	0.6	4.5	0.6	4.8	0.6	5.5	0.7	6.2	0.8
	2	3.1	0.5	3.5	0.5	4.2	0.6	4.5	0.6	4.8	0.7	5.5	0.7	6.2	0.8
	4	3.1	0.5	3.5	0.6	4.2	0.6	4.5	0.6	4.8	0.7	5.5	0.7	6.2	0.8
	6	3.1	0.6	3.5	0.6	4.2	0.6	4.5	0.6	4.8	0.7	5.5	0.7	6.2	0.8
	8	3.1	0.6	3.5	0.6	4.2	0.6	4.5	0.7	4.8	0.7	5.5	0.8	6.2	0.8
	10	3.1	0.6	3.5	0.6	4.2	0.6	4.5	0.7	4.8	0.7	5.5	0.8	6.2	0.9
	12	3.1	0.6	3.5	0.6	4.2	0.7	4.5	0.7	4.8	0.7	5.5	0.8	6.2	0.9
	14	3.1	0.6	3.5	0.6	4.2	0.7	4.5	0.7	4.8	0.8	5.5	0.8	6.2	0.9
	16	3.1	0.6	3.5	0.7	4.2	0.7	4.5	0.7	4.8	0.8	5.5	0.8	6.2	0.9
	18	3.1	0.6	3.5	0.7	4.2	0.7	4.5	0.8	4.8	0.8	5.5	0.9	6.2	0.9
	20	3.1	0.7	3.5	0.7	4.2	0.8	4.5	0.8	4.8	0.8	5.5	0.9	6.2	1.0
	21	3.1	0.7	3.5	0.7	4.2	0.8	4.5	0.8	4.8	0.8	5.5	0.9	6.2	1.0
	23	3.1	0.7	3.5	0.7	4.2	0.8	4.5	0.8	4.8	0.8	5.5	0.9	6.2	1.1
	25	3.1	0.7	3.5	0.7	4.2	0.8	4.5	0.9	4.8	0.9	5.5	1.0	6.2	1.2
27	3.1	0.7	3.5	0.8	4.2	0.8	4.5	0.9	4.8	0.9	5.5	1.1	6.2	1.3	
29	3.1	0.8	3.5	0.8	4.2	0.9	4.5	0.9	4.8	1.0	5.5	1.2	6.2	1.4	
31	3.1	0.8	3.5	0.8	4.2	0.9	4.5	1.0	4.8	1.1	5.5	1.2	6.2	1.5	
33	3.1	0.9	3.5	0.9	4.2	1.0	4.5	1.1	4.8	1.2	5.5	1.3	6.2	1.6	
35	3.1	0.9	3.5	1.0	4.2	1.1	4.5	1.2	4.8	1.3	5.5	1.5	6.2	1.7	
37	3.1	1.0	3.5	1.0	4.2	1.2	4.5	1.3	4.8	1.4	5.5	1.6	6.2	1.8	
39	3.1	1.0	3.5	1.1	4.2	1.3	4.5	1.4	4.8	1.5	5.5	1.7	6.2	2.0	
41	3.1	1.1	3.5	1.2	4.2	1.4	4.5	1.5	4.8	1.6	5.5	1.8	6.2	2.1	
43	3.1	1.2	3.5	1.2	4.2	1.5	4.5	1.6	4.8	1.7	5.5	1.9	6.2	2.3	
45	3.1	1.2	3.5	1.3	4.2	1.6	4.5	1.7	4.8	1.8	5.5	2.1	6.2	2.5	
48	3.1	1.4	3.5	1.5	4.2	1.7	4.5	1.9	4.8	2.0	5.5	2.3	6.2	2.7	
50	3.1	1.5	3.5	1.6	4.2	1.9	4.5	2.0	4.8	2.2	5.5	2.5	5.7	2.6	
52	3.1	1.6	3.5	1.7	4.0	1.9	4.2	2.0	4.4	2.1	4.9	2.2	5.1	2.3	

Abbreviations:

CR: Combination ratio

TC: Total capacity (kW)

PI: Power input (compressor + outdoor fan motor) (kW)

Notes:

Shaded cells indicate rating condition.

Table2-8.3:120 model cooling capacity - 220-240V~50Hz (continued)

CR	Outdoor air temp. (°CDB)	Indoor air temp. (°C DB/WD)													
		22/15		23.3/16		25.8/18		27/19		28.2/20		30.7/22		32/24	
		TC	PI	TC	PI	TC	PI	TC	PI	TC	PI	TC	PI	TC	PI
50%	-15	4.3	0.4	4.7	0.5	5.7	0.5	6.2	0.6	6.6	0.6	7.6	0.7	8.5	0.8
	-12	4.3	0.4	4.7	0.5	5.7	0.6	6.2	0.6	6.6	0.6	7.6	0.7	8.5	0.8
	-10	4.3	0.4	4.7	0.5	5.7	0.6	6.2	0.6	6.6	0.7	7.6	0.8	8.5	0.8
	-8	4.3	0.4	4.7	0.5	5.7	0.6	6.2	0.6	6.6	0.7	7.6	0.8	8.5	0.8
	-5	4.3	0.4	4.7	0.5	5.7	0.6	6.2	0.6	6.6	0.7	7.6	0.8	8.5	0.9
	-2	4.3	0.4	4.7	0.5	5.7	0.6	6.2	0.6	6.6	0.7	7.6	0.8	8.5	0.9
	0	4.3	0.4	4.7	0.5	5.7	0.6	6.2	0.6	6.6	0.7	7.6	0.8	8.5	0.9
	2	4.3	0.4	4.7	0.5	5.7	0.6	6.2	0.6	6.6	0.7	7.6	0.8	8.5	0.9
	4	4.3	0.4	4.7	0.5	5.7	0.6	6.2	0.6	6.6	0.7	7.6	0.8	8.5	0.9
	6	4.3	0.5	4.7	0.5	5.7	0.6	6.2	0.7	6.6	0.7	7.6	0.8	8.5	1.0
	8	4.3	0.5	4.7	0.5	5.7	0.6	6.2	0.7	6.6	0.7	7.6	0.8	8.5	1.0
	10	4.3	0.5	4.7	0.6	5.7	0.6	6.2	0.7	6.6	0.7	7.6	0.9	8.5	1.0
	12	4.3	0.5	4.7	0.6	5.7	0.6	6.2	0.7	6.6	0.7	7.6	0.9	8.5	1.1
	14	4.3	0.5	4.7	0.6	5.7	0.6	6.2	0.7	6.6	0.8	7.6	0.9	8.5	1.1
	16	4.3	0.6	4.7	0.6	5.7	0.7	6.2	0.7	6.6	0.8	7.6	0.9	8.5	1.1
	18	4.3	0.6	4.7	0.6	5.7	0.7	6.2	0.7	6.6	0.8	7.6	0.9	8.5	1.1
	20	4.3	0.7	4.7	0.7	5.7	0.8	6.2	0.8	6.6	0.9	7.6	1.0	8.5	1.2
	21	4.3	0.7	4.7	0.7	5.7	0.8	6.2	0.9	6.6	0.9	7.6	1.1	8.5	1.3
	23	4.3	0.7	4.7	0.8	5.7	0.9	6.2	1.0	6.6	1.0	7.6	1.2	8.5	1.4
	25	4.3	0.8	4.7	0.8	5.7	1.0	6.2	1.1	6.6	1.1	7.6	1.3	8.5	1.6
27	4.3	0.9	4.7	0.9	5.7	1.1	6.2	1.2	6.6	1.2	7.6	1.4	8.5	1.7	
29	4.3	0.9	4.7	1.0	5.7	1.2	6.2	1.3	6.6	1.4	7.6	1.5	8.5	1.9	
31	4.3	1.0	4.7	1.1	5.7	1.3	6.2	1.4	6.6	1.5	7.6	1.7	8.5	2.0	
33	4.3	1.1	4.7	1.2	5.7	1.4	6.2	1.5	6.6	1.6	7.6	1.8	8.5	2.2	
35	4.3	1.2	4.7	1.3	5.7	1.5	6.2	1.6	6.6	1.7	7.6	2.0	8.5	2.4	
37	4.3	1.2	4.7	1.3	5.7	1.6	6.2	1.7	6.6	1.8	7.6	2.1	8.5	2.6	
39	4.3	1.3	4.7	1.4	5.7	1.7	6.2	1.8	6.6	2.0	7.6	2.3	8.5	2.7	
41	4.3	1.4	4.7	1.5	5.7	1.8	6.2	2.0	6.6	2.1	7.6	2.5	8.5	3.0	
43	4.3	1.5	4.7	1.7	5.7	2.0	6.2	2.1	6.6	2.3	7.6	2.6	8.5	3.2	
45	4.3	1.6	4.7	1.8	5.7	2.1	6.2	2.3	6.6	2.5	7.6	2.9	8.5	3.4	
48	4.3	1.8	4.7	2.0	5.7	2.4	6.2	2.6	6.6	2.8	7.6	3.2	8.5	3.9	
50	4.3	1.9	4.7	2.1	5.7	2.5	6.2	2.8	6.6	3.0	7.6	3.5	8.0	3.7	
52	4.3	2.1	4.7	2.3	5.7	2.8	6.2	3.0	6.3	3.1	6.9	3.3	7.1	3.3	

Abbreviations:

CR: Combination ratio

TC: Total capacity (kW)

PI: Power input (compressor + outdoor fan motor) (kW)

Notes:

Shaded cells indicate rating condition.

Table2-8.4:140 model cooling capacity - 220-240V~50Hz (continued)

CR	Outdoor air temp. (°CDB)	Indoor air temp. (°C DB/WD)													
		22/15		23.3/16		25.8/18		27/19		28.2/20		30.7/22		32/24	
		TC	PI	TC	PI	TC	PI	TC	PI	TC	PI	TC	PI	TC	PI
50%	-15	4.8	0.5	5.4	0.5	6.5	0.6	7.0	0.7	7.5	0.8	8.6	0.9	9.7	1.0
	-12	4.8	0.5	5.4	0.5	6.5	0.6	7.0	0.7	7.5	0.8	8.6	0.9	9.7	1.0
	-10	4.8	0.5	5.4	0.5	6.5	0.6	7.0	0.7	7.5	0.8	8.6	0.9	9.7	1.0
	-8	4.8	0.5	5.4	0.5	6.5	0.7	7.0	0.7	7.5	0.8	8.6	0.9	9.7	1.0
	-5	4.8	0.5	5.4	0.6	6.5	0.7	7.0	0.7	7.5	0.8	8.6	0.9	9.7	1.0
	-2	4.8	0.5	5.4	0.6	6.5	0.7	7.0	0.7	7.5	0.8	8.6	0.9	9.7	1.0
	0	4.8	0.5	5.4	0.6	6.5	0.7	7.0	0.7	7.5	0.8	8.6	0.9	9.7	1.1
	2	4.8	0.5	5.4	0.6	6.5	0.7	7.0	0.7	7.5	0.8	8.6	0.9	9.7	1.2
	4	4.8	0.5	5.4	0.6	6.5	0.7	7.0	0.8	7.5	0.8	8.6	1.0	9.7	1.3
	6	4.8	0.5	5.4	0.6	6.5	0.7	7.0	0.8	7.5	0.9	8.6	1.0	9.7	1.4
	8	4.8	0.6	5.4	0.6	6.5	0.7	7.0	0.8	7.5	0.9	8.6	1.1	9.7	1.4
	10	4.8	0.6	5.4	0.6	6.5	0.8	7.0	0.9	7.5	1.0	8.6	1.1	9.7	1.4
	12	4.8	0.6	5.4	0.6	6.5	0.8	7.0	0.9	7.5	1.0	8.6	1.1	9.7	1.4
	14	4.8	0.6	5.4	0.6	6.5	0.8	7.0	0.9	7.5	1.0	8.6	1.1	9.7	1.4
	16	4.8	0.6	5.4	0.7	6.5	0.8	7.0	0.9	7.5	1.0	8.6	1.2	9.7	1.5
	18	4.8	0.7	5.4	0.7	6.5	0.8	7.0	0.9	7.5	1.0	8.6	1.2	9.7	1.5
	20	4.8	0.7	5.4	0.8	6.5	0.9	7.0	1.0	7.5	1.1	8.6	1.3	9.7	1.7
	21	4.8	0.8	5.4	0.8	6.5	1.0	7.0	1.1	7.5	1.2	8.6	1.4	9.7	1.7
	23	4.8	0.8	5.4	0.9	6.5	1.1	7.0	1.2	7.5	1.3	8.6	1.5	9.7	1.9
	25	4.8	0.9	5.4	1.0	6.5	1.2	7.0	1.3	7.5	1.4	8.6	1.7	9.7	2.1
27	4.8	1.0	5.4	1.1	6.5	1.3	7.0	1.4	7.5	1.5	8.6	1.8	9.7	2.2	
29	4.8	1.1	5.4	1.2	6.5	1.4	7.0	1.5	7.5	1.7	8.6	2.0	9.7	2.4	
31	4.8	1.2	5.4	1.3	6.5	1.5	7.0	1.7	7.5	1.8	8.6	2.1	9.7	2.6	
33	4.8	1.3	5.4	1.4	6.5	1.6	7.0	1.8	7.5	1.9	8.6	2.3	9.7	2.8	
35	4.8	1.3	5.4	1.5	6.5	1.8	7.0	1.9	7.5	2.1	8.6	2.5	9.7	3.0	
37	4.8	1.4	5.4	1.6	6.5	1.9	7.0	2.1	7.5	2.3	8.6	2.7	9.7	3.2	
39	4.8	1.5	5.4	1.7	6.5	2.0	7.0	2.2	7.5	2.4	8.6	2.9	9.7	3.5	
41	4.8	1.7	5.4	1.8	6.5	2.2	7.0	2.4	7.5	2.6	8.6	3.1	9.7	3.8	
43	4.8	1.8	5.4	2.0	6.5	2.4	7.0	2.6	7.5	2.8	8.6	3.3	9.7	4.0	
45	4.8	1.9	5.4	2.1	6.5	2.5	7.0	2.8	7.5	3.1	8.6	3.6	9.7	4.4	
48	4.8	2.1	5.4	2.4	6.5	2.9	7.0	3.1	7.5	3.4	8.6	4.0	9.0	4.3	
50	4.8	2.3	5.4	2.5	6.5	3.1	7.0	3.4	7.3	3.6	7.9	3.8	8.2	3.9	
52	4.8	2.5	5.4	2.8	5.9	3.0	6.2	3.1	6.5	3.2	7.1	3.3	7.2	3.3	

Abbreviations:

CR: Combination ratio

TC: Total capacity (kW)

PI: Power input (compressor + outdoor fan motor) (kW)

Notes:

Shaded cells indicate rating condition.

Table2-8.5:160 model cooling capacity - 220-240V~50Hz (continued)

CR	Outdoor air temp. (°CDB)	Indoor air temp. (°C DB/WD)													
		22/15		23.3/16		25.8/18		27/19		28.2/20		30.7/22		32/24	
		TC	PI	TC	PI	TC	PI	TC	PI	TC	PI	TC	PI	TC	PI
70%	-15	7.5	0.7	8.3	0.8	10.0	1.0	10.9	1.1	11.7	1.2	13.4	1.4	15.0	1.8
	-12	7.5	0.7	8.3	0.8	10.0	1.0	10.9	1.1	11.7	1.2	13.4	1.4	15.0	2.1
	-10	7.5	0.7	8.3	0.8	10.0	1.0	10.9	1.1	11.7	1.2	13.4	1.4	15.0	2.2
	-8	7.5	0.7	8.3	0.8	10.0	1.0	10.9	1.1	11.7	1.2	13.4	1.6	15.0	2.2
	-5	7.5	0.7	8.3	0.8	10.0	1.0	10.9	1.1	11.7	1.3	13.4	1.7	15.0	2.2
	-2	7.5	0.7	8.3	0.8	10.0	1.0	10.9	1.2	11.7	1.5	13.4	1.8	15.0	2.2
	0	7.5	0.8	8.3	0.9	10.0	1.1	10.9	1.4	11.7	1.5	13.4	1.9	15.0	2.3
	2	7.5	0.8	8.3	0.9	10.0	1.2	10.9	1.4	11.7	1.5	13.4	1.9	15.0	2.3
	4	7.5	0.8	8.3	0.9	10.0	1.2	10.9	1.4	11.7	1.5	13.4	1.9	15.0	2.3
	6	7.5	0.8	8.3	1.0	10.0	1.3	10.9	1.4	11.7	1.6	13.4	1.9	15.0	2.4
	8	7.5	0.9	8.3	1.0	10.0	1.3	10.9	1.4	11.7	1.6	13.4	1.9	15.0	2.4
	10	7.5	0.9	8.3	1.0	10.0	1.3	10.9	1.5	11.7	1.7	13.4	2.0	15.0	2.4
	12	7.5	1.0	8.3	1.1	10.0	1.4	10.9	1.5	11.7	1.7	13.4	2.0	15.0	2.5
	14	7.5	1.0	8.3	1.1	10.0	1.4	10.9	1.5	11.7	1.7	13.4	2.1	15.0	2.7
	16	7.5	1.0	8.3	1.1	10.0	1.5	10.9	1.6	11.7	1.8	13.4	2.2	15.0	2.9
	18	7.5	1.0	8.3	1.1	10.0	1.5	10.9	1.7	11.7	1.9	13.4	2.4	15.0	3.1
	20	7.5	1.1	8.3	1.2	10.0	1.6	10.9	1.9	11.7	2.1	13.4	2.6	15.0	3.4
	21	7.5	1.1	8.3	1.3	10.0	1.7	10.9	2.0	11.7	2.2	13.4	2.7	15.0	3.5
	23	7.5	1.3	8.3	1.4	10.0	1.9	10.9	2.1	11.7	2.4	13.4	2.9	15.0	3.8
	25	7.5	1.4	8.3	1.6	10.0	2.0	10.9	2.3	11.7	2.6	13.4	3.2	15.0	4.1
	27	7.5	1.5	8.3	1.7	10.0	2.2	10.9	2.5	11.7	2.8	13.4	3.4	15.0	4.4
	29	7.5	1.6	8.3	1.9	10.0	2.4	10.9	2.7	11.7	3.0	13.4	3.7	15.0	4.7
	31	7.5	1.8	8.3	2.0	10.0	2.6	10.9	2.9	11.7	3.2	13.4	3.9	15.0	5.0
	33	7.5	1.9	8.3	2.2	10.0	2.8	10.9	3.1	11.7	3.4	13.4	4.2	15.0	5.4
	35	7.5	2.1	8.3	2.3	10.0	3.0	10.9	3.3	11.7	3.7	13.4	4.5	15.0	5.8
	37	7.5	2.2	8.3	2.5	10.0	3.2	10.9	3.6	11.7	4.0	13.4	4.9	15.0	6.2
39	7.5	2.4	8.3	2.7	10.0	3.4	10.9	3.8	11.7	4.3	13.4	5.2	14.5	6.3	
41	7.5	2.6	8.3	2.9	10.0	3.7	10.9	4.1	11.7	4.6	13.4	5.6	13.7	5.9	
43	7.5	2.8	8.3	3.1	10.0	4.0	10.9	4.4	11.7	4.9	12.6	5.4	12.9	5.5	
45	7.5	3.0	8.3	3.4	10.0	4.3	10.9	4.8	11.1	4.9	11.8	5.1	12.1	5.2	
48	7.5	3.3	8.3	3.8	9.1	4.1	9.5	4.2	9.8	4.3	10.3	4.3	10.4	4.2	
50	7.0	3.3	7.4	3.4	8.1	3.7	8.5	3.8	8.8	3.8	8.8	3.5	8.9	3.4	
52	6.1	2.9	6.5	3.0	7.1	3.2	7.1	3.0	7.3	3.0	7.2	2.7	7.6	2.8	
60%	-15	6.4	0.6	7.2	0.7	8.6	0.8	9.3	0.9	10.0	1.0	11.4	1.1	12.9	1.3
	-12	6.4	0.6	7.2	0.7	8.6	0.8	9.3	0.9	10.0	1.0	11.4	1.2	12.9	1.3
	-10	6.4	0.6	7.2	0.7	8.6	0.8	9.3	0.9	10.0	1.0	11.4	1.2	12.9	1.4
	-8	6.4	0.6	7.2	0.7	8.6	0.8	9.3	0.9	10.0	1.0	11.4	1.2	12.9	1.6
	-5	6.4	0.6	7.2	0.7	8.6	0.9	9.3	0.9	10.0	1.0	11.4	1.2	12.9	1.8
	-2	6.4	0.6	7.2	0.7	8.6	0.9	9.3	0.9	10.0	1.0	11.4	1.4	12.9	1.8
	0	6.4	0.6	7.2	0.7	8.6	0.9	9.3	1.0	10.0	1.1	11.4	1.5	12.9	1.8
	2	6.4	0.7	7.2	0.7	8.6	0.9	9.3	1.0	10.0	1.2	11.4	1.5	12.9	1.8
	4	6.4	0.7	7.2	0.7	8.6	0.9	9.3	1.1	10.0	1.2	11.4	1.6	12.9	1.8
	6	6.4	0.7	7.2	0.8	8.6	1.0	9.3	1.1	10.0	1.2	11.4	1.6	12.9	1.9
	8	6.4	0.7	7.2	0.8	8.6	1.1	9.3	1.2	10.0	1.3	11.4	1.6	12.9	1.9
	10	6.4	0.8	7.2	0.9	8.6	1.1	9.3	1.2	10.0	1.3	11.4	1.6	12.9	2.0
	12	6.4	0.8	7.2	0.9	8.6	1.1	9.3	1.2	10.0	1.4	11.4	1.6	12.9	2.0
	14	6.4	0.8	7.2	0.9	8.6	1.1	9.3	1.3	10.0	1.4	11.4	1.7	12.9	2.1
	16	6.4	0.8	7.2	0.9	8.6	1.1	9.3	1.3	10.0	1.4	11.4	1.7	12.9	2.2
	18	6.4	0.8	7.2	0.9	8.6	1.2	9.3	1.3	10.0	1.5	11.4	1.9	12.9	2.4
	20	6.4	0.9	7.2	1.0	8.6	1.3	9.3	1.5	10.0	1.6	11.4	2.0	12.9	2.6
	21	6.4	1.0	7.2	1.1	8.6	1.3	9.3	1.5	10.0	1.7	11.4	2.1	12.9	2.7
	23	6.4	1.1	7.2	1.2	8.6	1.5	9.3	1.7	10.0	1.9	11.4	2.3	12.9	2.9
	25	6.4	1.2	7.2	1.3	8.6	1.6	9.3	1.8	10.0	2.0	11.4	2.5	12.9	3.1
	27	6.4	1.3	7.2	1.4	8.6	1.8	9.3	2.0	10.0	2.2	11.4	2.7	12.9	3.4
	29	6.4	1.4	7.2	1.5	8.6	1.9	9.3	2.1	10.0	2.4	11.4	2.9	12.9	3.6
	31	6.4	1.5	7.2	1.6	8.6	2.1	9.3	2.3	10.0	2.6	11.4	3.1	12.9	3.9
	33	6.4	1.6	7.2	1.8	8.6	2.2	9.3	2.5	10.0	2.8	11.4	3.3	12.9	4.2
	35	6.4	1.7	7.2	1.9	8.6	2.4	9.3	2.7	10.0	3.0	11.4	3.6	12.9	4.4
	37	6.4	1.8	7.2	2.1	8.6	2.6	9.3	2.9	10.0	3.2	11.4	3.8	12.9	4.8
39	6.4	2.0	7.2	2.2	8.6	2.8	9.3	3.1	10.0	3.4	11.4	4.1	12.9	5.1	
41	6.4	2.1	7.2	2.4	8.6	3.0	9.3	3.3	10.0	3.7	11.4	4.4	12.9	5.5	
43	6.4	2.3	7.2	2.6	8.6	3.2	9.3	3.6	10.0	4.0	11.4	4.8	12.2	5.3	
45	6.4	2.5	7.2	2.8	8.6	3.5	9.3	3.9	10.0	4.3	11.0	4.8	11.4	4.9	
48	6.4	2.8	7.2	3.1	8.6	3.9	8.8	4.0	9.1	4.1	9.8	4.3	10.2	4.4	
50	6.4	3.0	6.9	3.2	7.6	3.5	8.0	3.6	8.3	3.7	8.8	3.8	8.9	3.7	
52	5.6	2.7	6.1	2.9	6.7	3.1	7.2	3.3	7.2	3.2	7.5	3.0	7.5	2.9	

Abbreviations:

CR: Combination ratio

TC: Total capacity (kW)

PI: Power input (compressor + outdoor fan motor) (kW)

Notes:

Shaded cells indicate rating condition.

Table continued on next page ...

Table2-8.5:160 model cooling capacity - 220-240V~50Hz (continued)

CR	Outdoor air temp. (°CDB)	Indoor air temp. (°C DB/WD)													
		22/15		23.3/16		25.8/18		27/19		28.2/20		30.7/22		32/24	
		TC	PI	TC	PI	TC	PI	TC	PI	TC	PI	TC	PI	TC	PI
50%	-15	5.4	0.5	6.0	0.5	7.2	0.7	7.8	0.7	8.3	0.8	9.5	0.9	10.7	1.0
	-12	5.4	0.5	6.0	0.5	7.2	0.7	7.8	0.7	8.3	0.8	9.5	0.9	10.7	1.1
	-10	5.4	0.5	6.0	0.6	7.2	0.7	7.8	0.7	8.3	0.8	9.5	0.9	10.7	1.1
	-8	5.4	0.5	6.0	0.6	7.2	0.7	7.8	0.7	8.3	0.8	9.5	0.9	10.7	1.1
	-5	5.4	0.5	6.0	0.6	7.2	0.7	7.8	0.7	8.3	0.8	9.5	1.0	10.7	1.1
	-2	5.4	0.5	6.0	0.6	7.2	0.7	7.8	0.8	8.3	0.8	9.5	1.0	10.7	1.2
	0	5.4	0.5	6.0	0.6	7.2	0.7	7.8	0.8	8.3	0.8	9.5	1.0	10.7	1.4
	2	5.4	0.5	6.0	0.6	7.2	0.7	7.8	0.8	8.3	0.8	9.5	1.1	10.7	1.4
	4	5.4	0.5	6.0	0.6	7.2	0.7	7.8	0.8	8.3	0.9	9.5	1.2	10.7	1.4
	6	5.4	0.6	6.0	0.6	7.2	0.8	7.8	0.8	8.3	1.0	9.5	1.2	10.7	1.5
	8	5.4	0.6	6.0	0.6	7.2	0.8	7.8	0.9	8.3	1.0	9.5	1.2	10.7	1.6
	10	5.4	0.6	6.0	0.7	7.2	0.9	7.8	1.0	8.3	1.0	9.5	1.2	10.7	1.6
	12	5.4	0.6	6.0	0.7	7.2	0.9	7.8	1.0	8.3	1.1	9.5	1.3	10.7	1.6
	14	5.4	0.6	6.0	0.7	7.2	0.9	7.8	1.0	8.3	1.1	9.5	1.3	10.7	1.6
	16	5.4	0.6	6.0	0.7	7.2	0.9	7.8	1.0	8.3	1.1	9.5	1.3	10.7	1.7
	18	5.4	0.7	6.0	0.7	7.2	0.9	7.8	1.0	8.3	1.1	9.5	1.4	10.7	1.8
	20	5.4	0.8	6.0	0.8	7.2	1.0	7.8	1.1	8.3	1.2	9.5	1.5	10.7	1.9
	21	5.4	0.8	6.0	0.9	7.2	1.1	7.8	1.2	8.3	1.3	9.5	1.6	10.7	2.0
	23	5.4	0.9	6.0	1.0	7.2	1.2	7.8	1.3	8.3	1.4	9.5	1.7	10.7	2.2
	25	5.4	1.0	6.0	1.1	7.2	1.3	7.8	1.4	8.3	1.6	9.5	1.9	10.7	2.4
27	5.4	1.0	6.0	1.2	7.2	1.4	7.8	1.5	8.3	1.7	9.5	2.0	10.7	2.5	
29	5.4	1.1	6.0	1.3	7.2	1.5	7.8	1.7	8.3	1.8	9.5	2.2	10.7	2.7	
31	5.4	1.2	6.0	1.4	7.2	1.6	7.8	1.8	8.3	2.0	9.5	2.4	10.7	2.9	
33	5.4	1.3	6.0	1.5	7.2	1.8	7.8	1.9	8.3	2.1	9.5	2.6	10.7	3.2	
35	5.4	1.4	6.0	1.6	7.2	1.9	7.8	2.1	8.3	2.3	9.5	2.8	10.7	3.4	
37	5.4	1.5	6.0	1.7	7.2	2.0	7.8	2.3	8.3	2.5	9.5	3.0	10.7	3.6	
39	5.4	1.6	6.0	1.8	7.2	2.2	7.8	2.4	8.3	2.7	9.5	3.2	10.7	3.9	
41	5.4	1.8	6.0	1.9	7.2	2.4	7.8	2.6	8.3	2.9	9.5	3.4	10.7	4.2	
43	5.4	1.9	6.0	2.1	7.2	2.6	7.8	2.8	8.3	3.1	9.5	3.7	10.7	4.5	
45	5.4	2.0	6.0	2.2	7.2	2.8	7.8	3.0	8.3	3.3	9.5	4.0	10.4	4.6	
48	5.4	2.3	6.0	2.5	7.2	3.1	7.8	3.4	8.3	3.7	9.0	4.0	9.3	4.1	
50	5.4	2.4	6.0	2.7	6.9	3.2	7.3	3.3	7.5	3.4	8.2	3.7	8.6	3.8	
52	5.1	2.5	5.5	2.6	6.1	2.9	6.5	3.0	6.8	3.1	7.2	3.2	7.3	3.0	

Abbreviations:

CR: Combination ratio

TC: Total capacity (kW)

PI: Power input (compressor + outdoor fan motor) (kW)

Notes:

Shaded cells indicate rating condition.

Table2-8.6:120 model cooling capacity - 380-415V 3N~50Hz

CR	Outdoor air temp. (°CDB)	Indoor air temp. (°C DB/WD)													
		22/15		23.3/16		25.8/18		27/19		28.2/20		30.7/22		32/24	
		TC KW	PI KW	TC KW	PI KW	TC KW	PI KW	TC KW	PI KW	TC KW	PI KW	TC KW	PI KW	TC KW	PI KW
130%	-15	11.1	1.2	12.3	1.3	14.8	1.6	16.0	2.0	17.2	2.4	19.7	2.9	20.8	3.3
	-12	11.1	1.2	12.3	1.3	14.8	1.8	16.0	2.1	17.2	2.4	19.7	3.0	20.8	3.3
	-10	11.1	1.2	12.3	1.4	14.8	1.9	16.0	2.2	17.2	2.6	19.7	3.1	20.7	3.5
	-8	11.1	1.2	12.3	1.4	14.8	1.9	16.0	2.2	17.2	2.6	19.7	3.1	20.7	3.4
	-5	11.1	1.2	12.3	1.5	14.8	2.0	16.0	2.2	17.2	2.6	19.7	3.1	20.7	3.4
	-2	11.1	1.3	12.3	1.6	14.8	2.0	16.0	2.4	17.2	2.6	19.7	3.2	20.7	3.5
	0	11.1	1.4	12.3	1.7	14.8	2.1	16.0	2.4	17.2	2.6	19.7	3.2	20.7	3.5
	2	11.1	1.4	12.3	1.7	14.8	2.2	16.0	2.4	17.2	2.6	19.7	3.2	20.6	3.5
	4	11.1	1.4	12.3	1.7	14.8	2.2	16.0	2.4	17.2	2.7	19.7	3.2	20.5	3.6
	6	11.1	1.5	12.3	1.7	14.8	2.2	16.0	2.4	17.2	2.7	19.7	3.3	20.5	3.6
	8	11.1	1.5	12.3	1.7	14.8	2.2	16.0	2.5	17.2	2.7	19.7	3.5	20.4	3.7
	10	11.1	1.5	12.3	1.7	14.8	2.3	16.0	2.5	17.2	2.8	19.7	3.7	20.2	3.9
	12	11.1	1.6	12.3	1.8	14.8	2.3	16.0	2.6	17.2	3.0	19.7	4.0	20.0	4.1
	14	11.1	1.6	12.3	1.8	14.8	2.4	16.0	2.8	17.2	3.3	19.7	4.3	19.8	4.3
	16	11.1	1.6	12.3	1.9	14.8	2.6	16.0	3.0	17.2	3.5	19.2	4.5	19.6	4.5
	18	11.1	1.8	12.3	2.1	14.8	2.9	16.0	3.3	17.2	3.8	19.0	4.7	19.4	4.7
	20	11.1	2.0	12.3	2.3	14.8	3.1	16.0	3.6	17.2	4.1	18.8	4.9	19.2	4.9
	21	11.1	2.0	12.3	2.4	14.8	3.2	16.0	3.7	17.2	4.3	18.7	5.0	19.1	5.0
	23	11.1	2.2	12.3	2.6	14.8	3.5	16.0	4.0	17.2	4.6	18.5	5.2	18.9	5.3
	25	11.1	2.4	12.3	2.8	14.8	3.7	16.0	4.3	17.2	5.0	18.2	5.4	18.7	5.5
27	11.1	2.6	12.3	3.0	14.8	4.0	16.0	4.7	17.2	5.4	18.1	5.6	18.5	5.7	
29	11.1	2.8	12.3	3.3	14.8	4.3	16.0	5.0	17.2	5.8	17.8	5.9	18.2	5.9	
31	11.1	3.0	12.3	3.5	14.8	4.7	16.0	5.4	16.8	6.0	17.5	6.0	17.8	6.0	
33	11.1	3.3	12.3	3.8	14.8	5.0	16.0	5.8	16.4	6.0	17.0	6.1	17.5	6.1	
35	11.1	3.5	12.3	4.1	14.8	5.4	15.6	6.0	15.9	6.0	16.5	6.0	17.0	6.1	
37	11.1	3.8	12.3	4.4	14.8	5.8	15.1	6.0	15.4	6.0	16.0	6.0	16.4	6.0	
39	11.1	4.1	12.3	4.7	14.3	6.0	14.6	6.0	15.0	6.1	15.6	6.0	16.0	6.1	
41	11.1	4.4	12.3	5.1	13.9	6.0	14.2	6.0	14.4	6.0	15.2	6.1	15.4	6.0	
43	11.1	4.7	12.3	5.4	13.3	5.9	13.7	6.0	14.0	6.0	14.2	5.6	14.3	5.4	
45	11.1	5.1	11.5	5.2	12.3	5.5	12.4	5.4	12.6	5.3	12.9	5.0	13.0	4.9	
48	9.5	4.4	10.0	4.6	10.2	4.4	10.4	4.3	10.3	4.1	10.7	4.0	11.1	4.0	
50	8.5	4.0	8.6	3.9	8.6	3.6	8.7	3.5	8.8	3.4	9.3	3.4	9.0	3.0	
52	7.1	3.4	7.0	3.1	7.5	3.1	7.1	2.8	7.3	2.7	7.8	2.7	7.4	2.4	
120%	-15	10.2	1.1	11.4	1.2	13.6	1.5	14.8	1.6	15.9	1.9	18.2	2.5	20.4	3.4
	-12	10.2	1.1	11.4	1.2	13.6	1.5	14.8	1.8	15.9	2.1	18.2	2.7	20.4	3.4
	-10	10.2	1.1	11.4	1.2	13.6	1.5	14.8	1.9	15.9	2.2	18.2	2.7	20.4	3.6
	-8	10.2	1.1	11.4	1.2	13.6	1.7	14.8	1.9	15.9	2.2	18.2	2.7	20.4	3.6
	-5	10.2	1.1	11.4	1.2	13.6	1.7	14.8	1.9	15.9	2.3	18.2	2.7	20.4	3.6
	-2	10.2	1.1	11.4	1.4	13.6	1.7	14.8	2.0	15.9	2.3	18.2	2.7	20.0	3.5
	0	10.2	1.1	11.4	1.5	13.6	1.9	14.8	2.1	15.9	2.3	18.2	2.7	20.0	3.6
	2	10.2	1.3	11.4	1.5	13.6	1.9	14.8	2.1	15.9	2.4	18.2	2.7	20.0	3.7
	4	10.2	1.3	11.4	1.5	13.6	1.9	14.8	2.1	15.9	2.4	18.2	2.8	20.0	3.6
	6	10.2	1.3	11.4	1.5	13.6	1.9	14.8	2.1	15.9	2.4	18.2	2.8	19.9	3.6
	8	10.2	1.3	11.4	1.5	13.6	2.0	14.8	2.2	15.9	2.4	18.2	2.9	19.9	3.7
	10	10.2	1.4	11.4	1.6	13.6	2.0	14.8	2.3	15.9	2.5	18.2	3.0	19.7	3.9
	12	10.2	1.4	11.4	1.6	13.6	2.0	14.8	2.3	15.9	2.6	18.2	3.3	19.5	4.1
	14	10.2	1.4	11.4	1.6	13.6	2.1	14.8	2.4	15.9	2.7	18.2	3.6	19.3	4.3
	16	10.2	1.5	11.4	1.7	13.6	2.3	14.8	2.6	15.9	3.0	18.2	3.9	19.1	4.5
	18	10.2	1.6	11.4	1.8	13.6	2.5	14.8	2.8	15.9	3.2	18.2	4.2	18.9	4.7
	20	10.2	1.7	11.4	2.0	13.6	2.7	14.8	3.1	15.9	3.5	18.2	4.5	18.7	4.9
	21	10.2	1.8	11.4	2.1	13.6	2.8	14.8	3.2	15.9	3.6	18.2	4.7	18.7	5.0
	23	10.2	2.0	11.4	2.3	13.6	3.0	14.8	3.5	15.9	3.9	18.2	5.1	18.4	5.2
	25	10.2	2.1	11.4	2.5	13.6	3.3	14.8	3.7	15.9	4.3	18.2	5.5	18.3	5.4
27	10.2	2.3	11.4	2.7	13.6	3.5	14.8	4.0	15.9	4.6	17.6	5.6	18.0	5.6	
29	10.2	2.5	11.4	2.9	13.6	3.8	14.8	4.3	15.9	4.9	17.4	5.8	17.8	5.9	
31	10.2	2.7	11.4	3.1	13.6	4.1	14.8	4.6	15.9	5.3	17.1	6.0	17.5	6.0	
33	10.2	2.9	11.4	3.3	13.6	4.4	14.8	5.0	15.9	5.7	16.7	6.0	17.1	6.1	
35	10.2	3.1	11.4	3.6	13.6	4.7	14.8	5.4	15.9	6.1	16.2	6.0	16.6	6.0	
37	10.2	3.4	11.4	3.9	13.6	5.1	14.8	5.8	15.1	6.0	15.8	6.0	16.1	6.0	
39	10.2	3.6	11.4	4.2	13.6	5.4	14.4	6.0	14.7	6.0	15.3	6.1	15.7	6.0	
41	10.2	3.9	11.4	4.5	13.6	5.9	13.9	6.0	14.2	6.0	14.9	6.1	15.2	6.1	
43	10.2	4.2	11.4	4.8	13.0	5.8	13.4	5.9	13.8	6.0	14.2	5.8	14.2	5.7	
45	10.2	4.5	11.4	5.2	12.0	5.4	12.4	5.5	12.5	5.3	12.8	5.1	13.0	5.0	
48	9.3	4.4	9.7	4.5	10.2	4.5	10.2	4.3	10.3	4.2	10.8	4.1	10.7	3.9	
50	8.2	3.9	8.5	3.9	8.9	3.8	8.8	3.6	8.9	3.5	9.2	3.4	9.5	3.4	
52	7.0	3.3	7.3	3.4	7.2	3.0	7.4	3.0	7.3	2.8	7.7	2.7	8.0	2.7	

Abbreviations:

CR: Combination ratio; TC: Total capacity (kW); PI: Power input (compressor + outdoor fan motor) (kW)

Notes: Shaded cells indicate rating condition.

Table2-8.6:120 model cooling capacity - 380-415V 3N~50Hz (continued)

CR	Outdoor air temp. (°CDB)	Indoor air temp. (°C DB/WD)													
		22/15		23.3/16		25.8/18		27/19		28.2/20		30.7/22		32/24	
		TC	PI	TC	PI	TC	PI	TC	PI	TC	PI	TC	PI	TC	PI
70%	-15	6.0	0.6	6.6	0.7	7.9	0.8	8.6	0.8	9.3	0.9	10.6	1.1	11.9	1.3
	-12	6.0	0.6	6.6	0.7	7.9	0.8	8.6	0.9	9.3	0.9	10.6	1.1	11.9	1.3
	-10	6.0	0.6	6.6	0.7	7.9	0.8	8.6	0.9	9.3	0.9	10.6	1.1	11.9	1.3
	-8	6.0	0.6	6.6	0.7	7.9	0.8	8.6	0.9	9.3	1.0	10.6	1.1	11.9	1.3
	-5	6.0	0.6	6.6	0.7	7.9	0.8	8.6	0.9	9.3	1.0	10.6	1.1	11.9	1.3
	-2	6.0	0.6	6.6	0.7	7.9	0.8	8.6	0.9	9.3	1.0	10.6	1.1	11.9	1.5
	0	6.0	0.6	6.6	0.7	7.9	0.8	8.6	0.9	9.3	1.0	10.6	1.2	11.9	1.5
	2	6.0	0.6	6.6	0.7	7.9	0.8	8.6	0.9	9.3	1.0	10.6	1.3	11.9	1.5
	4	6.0	0.6	6.6	0.7	7.9	0.9	8.6	0.9	9.3	1.0	10.6	1.3	11.9	1.6
	6	6.0	0.6	6.6	0.7	7.9	0.9	8.6	1.0	9.3	1.0	10.6	1.3	11.9	1.6
	8	6.0	0.6	6.6	0.7	7.9	0.9	8.6	1.0	9.3	1.1	10.6	1.3	11.9	1.6
	10	6.0	0.7	6.6	0.7	7.9	1.0	8.6	1.0	9.3	1.1	10.6	1.3	11.9	1.6
	12	6.0	0.7	6.6	0.8	7.9	1.0	8.6	1.0	9.3	1.1	10.6	1.4	11.9	1.7
	14	6.0	0.7	6.6	0.8	7.9	1.0	8.6	1.1	9.3	1.1	10.6	1.4	11.9	1.7
	16	6.0	0.7	6.6	0.8	7.9	1.0	8.6	1.1	9.3	1.2	10.6	1.4	11.9	1.8
	18	6.0	0.7	6.6	0.8	7.9	1.0	8.6	1.1	9.3	1.2	10.6	1.5	11.9	2.0
	20	6.0	0.8	6.6	0.9	7.9	1.1	8.6	1.2	9.3	1.4	10.6	1.7	11.9	2.1
	21	6.0	0.9	6.6	1.0	7.9	1.2	8.6	1.3	9.3	1.4	10.6	1.8	11.9	2.2
	23	6.0	1.0	6.6	1.1	7.9	1.3	8.6	1.4	9.3	1.6	10.6	1.9	11.9	2.4
	25	6.0	1.1	6.6	1.2	7.9	1.4	8.6	1.6	9.3	1.8	10.6	2.1	11.9	2.6
	27	6.0	1.2	6.6	1.3	7.9	1.6	8.6	1.7	9.3	1.9	10.6	2.3	11.9	2.9
	29	6.0	1.3	6.6	1.4	7.9	1.7	8.6	1.9	9.3	2.1	10.6	2.5	11.9	3.1
	31	6.0	1.4	6.6	1.5	7.9	1.8	8.6	2.0	9.3	2.2	10.6	2.7	11.9	3.3
	33	6.0	1.5	6.6	1.6	7.9	2.0	8.6	2.2	9.3	2.4	10.6	2.9	11.9	3.6
35	6.0	1.6	6.6	1.8	7.9	2.1	8.6	2.4	9.3	2.6	10.6	3.1	11.9	3.8	
37	6.0	1.7	6.6	1.9	7.9	2.3	8.6	2.6	9.3	2.8	10.6	3.3	11.9	4.1	
39	6.0	1.8	6.6	2.0	7.9	2.5	8.6	2.8	9.3	3.0	10.6	3.6	11.9	4.4	
41	6.0	2.0	6.6	2.2	7.9	2.7	8.6	3.0	9.3	3.3	10.6	3.9	11.9	4.8	
43	6.0	2.1	6.6	2.3	7.9	2.9	8.6	3.2	9.3	3.5	10.6	4.2	11.9	5.1	
45	6.0	2.3	6.6	2.5	7.9	3.1	8.6	3.4	9.3	3.8	10.6	4.5	11.5	5.2	
48	6.0	2.5	6.6	2.8	7.9	3.5	8.6	3.9	9.3	4.3	9.9	4.5	10.2	4.6	
50	6.0	2.8	6.6	3.1	7.7	3.7	8.1	3.8	8.4	3.9	8.7	3.8	8.8	3.7	
52	5.7	2.9	6.1	3.0	6.9	3.3	7.1	3.3	7.2	3.2	7.4	3.1	7.5	3.0	
60%	-15	5.1	0.5	5.7	0.5	6.8	0.7	7.4	0.7	7.9	0.8	9.1	0.9	10.2	1.0
	-12	5.1	0.5	5.7	0.5	6.8	0.7	7.4	0.7	7.9	0.8	9.1	0.9	10.2	1.0
	-10	5.1	0.5	5.7	0.6	6.8	0.7	7.4	0.7	7.9	0.8	9.1	0.9	10.2	1.1
	-8	5.1	0.5	5.7	0.6	6.8	0.7	7.4	0.7	7.9	0.8	9.1	0.9	10.2	1.1
	-5	5.1	0.5	5.7	0.6	6.8	0.7	7.4	0.7	7.9	0.8	9.1	0.9	10.2	1.1
	-2	5.1	0.5	5.7	0.6	6.8	0.7	7.4	0.8	7.9	0.8	9.1	0.9	10.2	1.1
	0	5.1	0.5	5.7	0.6	6.8	0.7	7.4	0.8	7.9	0.8	9.1	1.0	10.2	1.1
	2	5.1	0.5	5.7	0.6	6.8	0.7	7.4	0.8	7.9	0.8	9.1	1.0	10.2	1.2
	4	5.1	0.5	5.7	0.6	6.8	0.7	7.4	0.8	7.9	0.8	9.1	1.0	10.2	1.2
	6	5.1	0.6	5.7	0.6	6.8	0.7	7.4	0.8	7.9	0.9	9.1	1.1	10.2	1.3
	8	5.1	0.6	5.7	0.6	6.8	0.8	7.4	0.8	7.9	0.9	9.1	1.1	10.2	1.3
	10	5.1	0.6	5.7	0.6	6.8	0.8	7.4	0.9	7.9	0.9	9.1	1.1	10.2	1.3
	12	5.1	0.6	5.7	0.6	6.8	0.8	7.4	0.9	7.9	1.0	9.1	1.1	10.2	1.4
	14	5.1	0.6	5.7	0.6	6.8	0.8	7.4	0.9	7.9	1.0	9.1	1.1	10.2	1.4
	16	5.1	0.6	5.7	0.6	6.8	0.8	7.4	0.9	7.9	1.0	9.1	1.1	10.2	1.5
	18	5.1	0.6	5.7	0.7	6.8	0.8	7.4	0.9	7.9	1.0	9.1	1.2	10.2	1.5
	20	5.1	0.7	5.7	0.8	6.8	0.9	7.4	1.0	7.9	1.1	9.1	1.3	10.2	1.7
	21	5.1	0.8	5.7	0.8	6.8	1.0	7.4	1.1	7.9	1.2	9.1	1.4	10.2	1.7
	23	5.1	0.8	5.7	0.9	6.8	1.1	7.4	1.2	7.9	1.3	9.1	1.5	10.2	1.9
	25	5.1	0.9	5.7	1.0	6.8	1.2	7.4	1.3	7.9	1.4	9.1	1.7	10.2	2.1
	27	5.1	1.0	5.7	1.1	6.8	1.3	7.4	1.4	7.9	1.5	9.1	1.8	10.2	2.3
	29	5.1	1.1	5.7	1.2	6.8	1.4	7.4	1.5	7.9	1.7	9.1	2.0	10.2	2.4
	31	5.1	1.2	5.7	1.3	6.8	1.5	7.4	1.7	7.9	1.8	9.1	2.1	10.2	2.6
	33	5.1	1.3	5.7	1.4	6.8	1.6	7.4	1.8	7.9	2.0	9.1	2.3	10.2	2.8
35	5.1	1.4	5.7	1.5	6.8	1.8	7.4	1.9	7.9	2.1	9.1	2.5	10.2	3.0	
37	5.1	1.5	5.7	1.6	6.8	1.9	7.4	2.1	7.9	2.3	9.1	2.7	10.2	3.3	
39	5.1	1.6	5.7	1.7	6.8	2.1	7.4	2.2	7.9	2.5	9.1	2.9	10.2	3.5	
41	5.1	1.7	5.7	1.8	6.8	2.2	7.4	2.4	7.9	2.7	9.1	3.1	10.2	3.8	
43	5.1	1.8	5.7	2.0	6.8	2.4	7.4	2.6	7.9	2.9	9.1	3.4	10.2	4.1	
45	5.1	1.9	5.7	2.1	6.8	2.6	7.4	2.8	7.9	3.1	9.1	3.6	10.2	4.4	
48	5.1	2.2	5.7	2.4	6.8	2.9	7.4	3.2	7.9	3.5	9.1	4.1	9.6	4.4	
50	5.1	2.3	5.7	2.6	6.8	3.1	7.4	3.4	7.9	3.8	8.4	3.9	8.7	3.9	
52	5.1	2.5	5.7	2.8	6.4	3.1	6.7	3.2	7.0	3.3	7.1	3.1	7.3	3.1	

Abbreviations:

CR: Combination ratio

TC: Total capacity (kW)

PI: Power input (compressor + outdoor fan motor) (kW)

Notes:

Shaded cells indicate rating condition.

Table continued on next page ...

Table2-8.6:120 model cooling capacity - 380-415V 3N~50Hz (continued)

CR	Outdoor air temp. (°CDB)	Indoor air temp. (°C DB/WD)													
		22/15		23.3/16		25.8/18		27/19		28.2/20		30.7/22		32/24	
		TC	PI	TC	PI	TC	PI	TC	PI	TC	PI	TC	PI	TC	PI
50%	-15	4.3	0.4	4.7	0.5	5.7	0.5	6.2	0.6	6.6	0.6	7.6	0.7	8.5	0.8
	-12	4.3	0.4	4.7	0.5	5.7	0.6	6.2	0.6	6.6	0.6	7.6	0.7	8.5	0.8
	-10	4.3	0.4	4.7	0.5	5.7	0.6	6.2	0.6	6.6	0.7	7.6	0.8	8.5	0.8
	-8	4.3	0.4	4.7	0.5	5.7	0.6	6.2	0.6	6.6	0.7	7.6	0.8	8.5	0.8
	-5	4.3	0.4	4.7	0.5	5.7	0.6	6.2	0.6	6.6	0.7	7.6	0.8	8.5	0.9
	-2	4.3	0.4	4.7	0.5	5.7	0.6	6.2	0.6	6.6	0.7	7.6	0.8	8.5	0.9
	0	4.3	0.4	4.7	0.5	5.7	0.6	6.2	0.6	6.6	0.7	7.6	0.8	8.5	0.9
	2	4.3	0.4	4.7	0.5	5.7	0.6	6.2	0.6	6.6	0.7	7.6	0.8	8.5	0.9
	4	4.3	0.4	4.7	0.5	5.7	0.6	6.2	0.6	6.6	0.7	7.6	0.8	8.5	0.9
	6	4.3	0.5	4.7	0.5	5.7	0.6	6.2	0.7	6.6	0.7	7.6	0.8	8.5	1.0
	8	4.3	0.5	4.7	0.5	5.7	0.6	6.2	0.7	6.6	0.7	7.6	0.8	8.5	1.0
	10	4.3	0.5	4.7	0.6	5.7	0.6	6.2	0.7	6.6	0.7	7.6	0.9	8.5	1.0
	12	4.3	0.5	4.7	0.6	5.7	0.6	6.2	0.7	6.6	0.7	7.6	0.9	8.5	1.1
	14	4.3	0.5	4.7	0.6	5.7	0.6	6.2	0.7	6.6	0.8	7.6	0.9	8.5	1.1
	16	4.3	0.6	4.7	0.6	5.7	0.7	6.2	0.7	6.6	0.8	7.6	0.9	8.5	1.1
	18	4.3	0.6	4.7	0.6	5.7	0.7	6.2	0.7	6.6	0.8	7.6	0.9	8.5	1.1
	20	4.3	0.7	4.7	0.7	5.7	0.8	6.2	0.8	6.6	0.9	7.6	1.0	8.5	1.2
	21	4.3	0.7	4.7	0.7	5.7	0.8	6.2	0.9	6.6	0.9	7.6	1.1	8.5	1.3
	23	4.3	0.7	4.7	0.8	5.7	0.9	6.2	1.0	6.6	1.0	7.6	1.2	8.5	1.4
	25	4.3	0.8	4.7	0.8	5.7	1.0	6.2	1.1	6.6	1.1	7.6	1.3	8.5	1.6
27	4.3	0.9	4.7	0.9	5.7	1.1	6.2	1.2	6.6	1.2	7.6	1.4	8.5	1.7	
29	4.3	0.9	4.7	1.0	5.7	1.2	6.2	1.3	6.6	1.4	7.6	1.5	8.5	1.9	
31	4.3	1.0	4.7	1.1	5.7	1.3	6.2	1.4	6.6	1.5	7.6	1.7	8.5	2.0	
33	4.3	1.1	4.7	1.2	5.7	1.4	6.2	1.5	6.6	1.6	7.6	1.8	8.5	2.2	
35	4.3	1.2	4.7	1.3	5.7	1.5	6.2	1.6	6.6	1.7	7.6	2.0	8.5	2.4	
37	4.3	1.2	4.7	1.3	5.7	1.6	6.2	1.7	6.6	1.8	7.6	2.1	8.5	2.6	
39	4.3	1.3	4.7	1.4	5.7	1.7	6.2	1.8	6.6	2.0	7.6	2.3	8.5	2.7	
41	4.3	1.4	4.7	1.5	5.7	1.8	6.2	2.0	6.6	2.1	7.6	2.5	8.5	3.0	
43	4.3	1.5	4.7	1.7	5.7	2.0	6.2	2.1	6.6	2.3	7.6	2.6	8.5	3.2	
45	4.3	1.6	4.7	1.8	5.7	2.1	6.2	2.3	6.6	2.5	7.6	2.9	8.5	3.4	
48	4.3	1.8	4.7	2.0	5.7	2.4	6.2	2.6	6.6	2.8	7.6	3.2	8.5	3.9	
50	4.3	1.9	4.7	2.1	5.7	2.5	6.2	2.8	6.6	3.0	7.6	3.5	8.0	3.7	
52	4.3	2.1	4.7	2.3	5.7	2.8	6.2	3.0	6.3	3.1	6.9	3.3	7.1	3.3	

Abbreviations:

CR: Combination ratio

TC: Total capacity (kW)

PI: Power input (compressor + outdoor fan motor) (kW)

Notes:

Shaded cells indicate rating condition.

Table2-8.7:140 model cooling capacity - 380-415V 3N~50Hz (continued)

CR	Outdoor air temp. (°CDB)	Indoor air temp. (°C DB/WD)													
		22/15		23.3/16		25.8/18		27/19		28.2/20		30.7/22		32/24	
		TC	PI	TC	PI	TC	PI	TC	PI	TC	PI	TC	PI	TC	PI
50%	-15	4.8	0.5	5.4	0.5	6.5	0.6	7.0	0.7	7.5	0.8	8.6	0.9	9.7	1.0
	-12	4.8	0.5	5.4	0.5	6.5	0.6	7.0	0.7	7.5	0.8	8.6	0.9	9.7	1.0
	-10	4.8	0.5	5.4	0.5	6.5	0.6	7.0	0.7	7.5	0.8	8.6	0.9	9.7	1.0
	-8	4.8	0.5	5.4	0.5	6.5	0.7	7.0	0.7	7.5	0.8	8.6	0.9	9.7	1.0
	-5	4.8	0.5	5.4	0.6	6.5	0.7	7.0	0.7	7.5	0.8	8.6	0.9	9.7	1.0
	-2	4.8	0.5	5.4	0.6	6.5	0.7	7.0	0.7	7.5	0.8	8.6	0.9	9.7	1.0
	0	4.8	0.5	5.4	0.6	6.5	0.7	7.0	0.7	7.5	0.8	8.6	0.9	9.7	1.1
	2	4.8	0.5	5.4	0.6	6.5	0.7	7.0	0.7	7.5	0.8	8.6	0.9	9.7	1.2
	4	4.8	0.5	5.4	0.6	6.5	0.7	7.0	0.8	7.5	0.8	8.6	1.0	9.7	1.3
	6	4.8	0.5	5.4	0.6	6.5	0.7	7.0	0.8	7.5	0.9	8.6	1.0	9.7	1.4
	8	4.8	0.6	5.4	0.6	6.5	0.7	7.0	0.8	7.5	0.9	8.6	1.1	9.7	1.4
	10	4.8	0.6	5.4	0.6	6.5	0.8	7.0	0.9	7.5	1.0	8.6	1.1	9.7	1.4
	12	4.8	0.6	5.4	0.6	6.5	0.8	7.0	0.9	7.5	1.0	8.6	1.1	9.7	1.4
	14	4.8	0.6	5.4	0.6	6.5	0.8	7.0	0.9	7.5	1.0	8.6	1.1	9.7	1.4
	16	4.8	0.6	5.4	0.7	6.5	0.8	7.0	0.9	7.5	1.0	8.6	1.2	9.7	1.5
	18	4.8	0.7	5.4	0.7	6.5	0.8	7.0	0.9	7.5	1.0	8.6	1.2	9.7	1.5
	20	4.8	0.7	5.4	0.8	6.5	0.9	7.0	1.0	7.5	1.1	8.6	1.3	9.7	1.7
	21	4.8	0.8	5.4	0.8	6.5	1.0	7.0	1.1	7.5	1.2	8.6	1.4	9.7	1.7
	23	4.8	0.8	5.4	0.9	6.5	1.1	7.0	1.2	7.5	1.3	8.6	1.5	9.7	1.9
	25	4.8	0.9	5.4	1.0	6.5	1.2	7.0	1.3	7.5	1.4	8.6	1.7	9.7	2.1
27	4.8	1.0	5.4	1.1	6.5	1.3	7.0	1.4	7.5	1.5	8.6	1.8	9.7	2.2	
29	4.8	1.1	5.4	1.2	6.5	1.4	7.0	1.5	7.5	1.7	8.6	2.0	9.7	2.4	
31	4.8	1.2	5.4	1.3	6.5	1.5	7.0	1.7	7.5	1.8	8.6	2.1	9.7	2.6	
33	4.8	1.3	5.4	1.4	6.5	1.6	7.0	1.8	7.5	1.9	8.6	2.3	9.7	2.8	
35	4.8	1.3	5.4	1.5	6.5	1.8	7.0	1.9	7.5	2.1	8.6	2.5	9.7	3.0	
37	4.8	1.4	5.4	1.6	6.5	1.9	7.0	2.1	7.5	2.3	8.6	2.7	9.7	3.2	
39	4.8	1.5	5.4	1.7	6.5	2.0	7.0	2.2	7.5	2.4	8.6	2.9	9.7	3.5	
41	4.8	1.7	5.4	1.8	6.5	2.2	7.0	2.4	7.5	2.6	8.6	3.1	9.7	3.8	
43	4.8	1.8	5.4	2.0	6.5	2.4	7.0	2.6	7.5	2.8	8.6	3.3	9.7	4.0	
45	4.8	1.9	5.4	2.1	6.5	2.5	7.0	2.8	7.5	3.1	8.6	3.6	9.7	4.4	
48	4.8	2.1	5.4	2.4	6.5	2.9	7.0	3.1	7.5	3.4	8.6	4.0	9.0	4.3	
50	4.8	2.3	5.4	2.5	6.5	3.1	7.0	3.4	7.3	3.6	7.9	3.8	8.2	3.9	
52	4.8	2.5	5.4	2.8	5.9	3.0	6.2	3.1	6.5	3.2	7.1	3.3	7.2	3.3	

Abbreviations:

CR: Combination ratio

TC: Total capacity (kW)

PI: Power input (compressor + outdoor fan motor) (kW)

Notes:

Shaded cells indicate rating condition.

Table2-8.8:160 model cooling capacity - 380-415V 3N~50Hz (continued)

CR	Outdoor air temp. (°CDB)	Indoor air temp. (°C DB/WD)													
		22/15		23.3/16		25.8/18		27/19		28.2/20		30.7/22		32/24	
		TC	PI	TC	PI	TC	PI	TC	PI	TC	PI	TC	PI	TC	PI
50%	-15	5.4	0.5	6.0	0.5	7.2	0.7	7.8	0.7	8.3	0.8	9.5	0.9	10.7	1.0
	-12	5.4	0.5	6.0	0.5	7.2	0.7	7.8	0.7	8.3	0.8	9.5	0.9	10.7	1.1
	-10	5.4	0.5	6.0	0.6	7.2	0.7	7.8	0.7	8.3	0.8	9.5	0.9	10.7	1.1
	-8	5.4	0.5	6.0	0.6	7.2	0.7	7.8	0.7	8.3	0.8	9.5	0.9	10.7	1.1
	-5	5.4	0.5	6.0	0.6	7.2	0.7	7.8	0.7	8.3	0.8	9.5	1.0	10.7	1.1
	-2	5.4	0.5	6.0	0.6	7.2	0.7	7.8	0.8	8.3	0.8	9.5	1.0	10.7	1.2
	0	5.4	0.5	6.0	0.6	7.2	0.7	7.8	0.8	8.3	0.8	9.5	1.0	10.7	1.4
	2	5.4	0.5	6.0	0.6	7.2	0.7	7.8	0.8	8.3	0.8	9.5	1.1	10.7	1.4
	4	5.4	0.5	6.0	0.6	7.2	0.7	7.8	0.8	8.3	0.9	9.5	1.2	10.7	1.4
	6	5.4	0.6	6.0	0.6	7.2	0.8	7.8	0.8	8.3	1.0	9.5	1.2	10.7	1.5
	8	5.4	0.6	6.0	0.6	7.2	0.8	7.8	0.9	8.3	1.0	9.5	1.2	10.7	1.6
	10	5.4	0.6	6.0	0.7	7.2	0.9	7.8	1.0	8.3	1.0	9.5	1.2	10.7	1.6
	12	5.4	0.6	6.0	0.7	7.2	0.9	7.8	1.0	8.3	1.1	9.5	1.3	10.7	1.6
	14	5.4	0.6	6.0	0.7	7.2	0.9	7.8	1.0	8.3	1.1	9.5	1.3	10.7	1.6
	16	5.4	0.6	6.0	0.7	7.2	0.9	7.8	1.0	8.3	1.1	9.5	1.3	10.7	1.7
	18	5.4	0.7	6.0	0.7	7.2	0.9	7.8	1.0	8.3	1.1	9.5	1.4	10.7	1.8
	20	5.4	0.8	6.0	0.8	7.2	1.0	7.8	1.1	8.3	1.2	9.5	1.5	10.7	1.9
	21	5.4	0.8	6.0	0.9	7.2	1.1	7.8	1.2	8.3	1.3	9.5	1.6	10.7	2.0
	23	5.4	0.9	6.0	1.0	7.2	1.2	7.8	1.3	8.3	1.4	9.5	1.7	10.7	2.2
	25	5.4	1.0	6.0	1.1	7.2	1.3	7.8	1.4	8.3	1.6	9.5	1.9	10.7	2.4
27	5.4	1.0	6.0	1.2	7.2	1.4	7.8	1.5	8.3	1.7	9.5	2.0	10.7	2.5	
29	5.4	1.1	6.0	1.3	7.2	1.5	7.8	1.7	8.3	1.8	9.5	2.2	10.7	2.7	
31	5.4	1.2	6.0	1.4	7.2	1.6	7.8	1.8	8.3	2.0	9.5	2.4	10.7	2.9	
33	5.4	1.3	6.0	1.5	7.2	1.8	7.8	1.9	8.3	2.1	9.5	2.6	10.7	3.2	
35	5.4	1.4	6.0	1.6	7.2	1.9	7.8	2.1	8.3	2.3	9.5	2.8	10.7	3.4	
37	5.4	1.5	6.0	1.7	7.2	2.0	7.8	2.3	8.3	2.5	9.5	3.0	10.7	3.6	
39	5.4	1.6	6.0	1.8	7.2	2.2	7.8	2.4	8.3	2.7	9.5	3.2	10.7	3.9	
41	5.4	1.8	6.0	1.9	7.2	2.4	7.8	2.6	8.3	2.9	9.5	3.4	10.7	4.2	
43	5.4	1.9	6.0	2.1	7.2	2.6	7.8	2.8	8.3	3.1	9.5	3.7	10.7	4.5	
45	5.4	2.0	6.0	2.2	7.2	2.8	7.8	3.0	8.3	3.3	9.5	4.0	10.4	4.6	
48	5.4	2.3	6.0	2.5	7.2	3.1	7.8	3.4	8.3	3.7	9.0	4.0	9.3	4.1	
50	5.4	2.4	6.0	2.7	6.9	3.2	7.3	3.3	7.5	3.4	8.2	3.7	8.6	3.8	
52	5.1	2.5	5.5	2.6	6.1	2.9	6.5	3.0	6.8	3.1	7.2	3.2	7.3	3.0	

Abbreviations:

CR: Combination ratio

TC: Total capacity (kW)

PI: Power input (compressor + outdoor fan motor) (kW)

Notes:

Shaded cells indicate rating condition.

8.2 Heating Capacity Tables

Table2-8.6:80 model heating capacity - 220-240V~50Hz

CR	Outdoor air temp.		Indoor air temp. °C DB											
			16.0		18.0		20.0		21.0		22.0		24.0	
	°C DB	°C WB	TC	PI	TC	PI	TC	PI	TC	PI	TC	PI	TC	PI
130%	-19.8	-20.0	6.1	2.6	6.0	2.7	6.0	2.8	6.0	2.8	6.0	2.9	5.9	2.9
	-18.8	-19.0	6.3	2.6	6.3	2.7	6.2	2.8	6.2	2.9	6.2	2.9	6.1	3.0
	-16.7	-17.0	6.7	2.7	6.7	2.8	6.7	2.9	6.6	2.9	6.6	3.0	6.5	3.1
	-13.7	-15.0	7.2	2.8	7.1	2.9	7.1	3.0	7.1	3.0	7.0	3.1	7.0	3.2
	-11.8	-13.0	7.6	2.9	7.6	3.0	7.5	3.1	7.5	3.1	7.5	3.2	7.4	3.2
	-9.8	-11.0	8.1	2.9	8.0	3.0	8.0	3.1	8.0	3.2	7.9	3.2	7.9	3.3
	-9.5	-10.0	8.3	3.0	8.3	3.1	8.2	3.2	8.2	3.2	8.1	3.3	8.1	3.4
	-8.5	-9.1	8.5	3.0	8.5	3.1	8.4	3.2	8.4	3.3	8.3	3.3	8.3	3.4
	-7.0	-7.6	8.9	3.1	8.8	3.2	8.8	3.3	8.7	3.3	8.7	3.4	8.6	3.5
	-5.0	-5.6	9.3	3.1	9.3	3.3	9.2	3.4	9.2	3.4	9.1	3.5	9.1	3.6
	-3.0	-3.7	9.8	3.2	9.7	3.3	9.7	3.4	9.6	3.5	9.6	3.5	9.5	3.7
	0.0	-0.7	10.5	3.3	10.5	3.5	10.4	3.6	10.3	3.6	10.3	3.7	9.9	3.5
	3.0	2.2	11.3	3.5	11.2	3.6	11.1	3.7	11.3	3.8	10.8	3.6	9.9	3.3
	5.0	4.1	11.8	3.5	11.7	3.7	11.7	3.8	11.3	3.6	10.8	3.4	9.9	3.1
	7.0	6.0	12.3	3.6	12.2	3.7	11.7	3.6	11.3	3.4	10.8	3.2	9.9	3.0
9.0	7.9	12.8	3.7	12.6	3.7	11.7	3.4	11.3	3.2	10.8	3.1	9.9	2.8	
11.0	9.8	13.5	3.8	12.6	3.5	11.7	3.2	11.3	3.1	10.8	2.9	9.9	2.7	
13.0	11.8	13.5	3.6	12.6	3.3	11.7	3.0	11.3	2.9	10.8	2.8	9.9	2.5	
15.0	13.7	13.5	3.4	12.6	3.1	11.7	2.9	11.3	2.7	10.8	2.6	9.9	2.4	
120%	-19.8	-20.0	6.0	2.6	6.0	2.7	6.0	2.8	6.0	2.8	5.9	2.9	5.9	2.9
	-18.8	-19.0	6.3	2.6	6.2	2.7	6.2	2.8	6.2	2.9	6.1	2.9	6.1	3.0
	-16.7	-17.0	6.7	2.7	6.7	2.8	6.6	2.9	6.6	2.9	6.6	3.0	6.5	3.1
	-13.7	-15.0	7.1	2.8	7.1	2.9	7.1	3.0	7.0	3.0	7.0	3.1	6.9	3.2
	-11.8	-13.0	7.6	2.9	7.6	3.0	7.5	3.1	7.5	3.1	7.4	3.2	7.4	3.3
	-9.8	-11.0	8.0	3.0	8.0	3.1	7.9	3.2	7.9	3.2	7.9	3.3	7.8	3.3
	-9.5	-10.0	8.3	3.0	8.2	3.1	8.2	3.2	8.1	3.3	8.1	3.3	8.0	3.4
	-8.5	-9.1	8.5	3.0	8.4	3.1	8.4	3.2	8.3	3.3	8.3	3.3	8.2	3.4
	-7.0	-7.6	8.8	3.1	8.8	3.2	8.7	3.3	8.7	3.4	8.6	3.4	8.5	3.5
	-5.0	-5.6	9.3	3.2	9.2	3.3	9.2	3.4	9.1	3.4	9.1	3.5	9.1	3.6
	-3.0	-3.7	9.7	3.3	9.7	3.4	9.6	3.5	9.6	3.5	9.5	3.6	9.1	3.4
	0.0	-0.7	10.5	3.4	10.4	3.5	10.3	3.6	10.4	3.7	10.0	3.5	9.1	3.2
	3.0	2.2	11.2	3.5	11.1	3.6	10.8	3.5	10.4	3.4	10.0	3.2	9.1	3.0
	5.0	4.1	11.7	3.6	11.6	3.7	10.8	3.3	10.4	3.2	10.0	3.1	9.1	2.8
	7.0	6.0	12.5	3.8	11.6	3.5	10.8	3.2	10.4	3.0	10.0	2.9	9.1	2.7
9.0	7.9	12.5	3.6	11.6	3.3	10.8	3.0	10.4	2.9	10.0	2.8	9.1	2.5	
11.0	9.8	12.5	3.3	11.6	3.1	10.8	2.9	10.4	2.7	10.0	2.6	9.1	2.4	
13.0	11.8	12.5	3.2	11.6	2.9	10.8	2.7	10.4	2.6	10.0	2.5	9.1	2.3	
15.0	13.7	12.5	3.0	11.6	2.8	10.8	2.6	10.4	2.4	10.0	2.3	9.1	2.1	
110%	-19.8	-20.0	6.0	2.6	6.0	2.7	5.9	2.8	5.9	2.8	5.9	2.9	5.8	2.9
	-18.8	-19.0	6.3	2.6	6.2	2.7	6.2	2.8	6.1	2.9	6.1	2.9	6.0	3.0
	-16.7	-17.0	6.7	2.7	6.6	2.8	6.6	2.9	6.6	3.0	6.5	3.0	6.5	3.1
	-13.7	-15.0	7.1	2.8	7.1	2.9	7.0	3.0	7.0	3.1	7.0	3.1	6.9	3.2
	-11.8	-13.0	7.6	2.9	7.5	3.0	7.4	3.1	7.4	3.1	7.4	3.2	7.3	3.3
	-9.8	-11.0	8.0	3.0	7.9	3.1	7.9	3.2	7.8	3.2	7.8	3.3	7.7	3.4
	-9.5	-10.0	8.2	3.0	8.2	3.1	8.1	3.2	8.1	3.3	8.0	3.3	7.9	3.4
	-8.5	-9.1	8.4	3.1	8.4	3.2	8.3	3.3	8.3	3.3	8.2	3.4	8.1	3.5
	-7.0	-7.6	8.8	3.1	8.7	3.2	8.6	3.3	8.6	3.4	8.6	3.4	8.4	3.4
	-5.0	-5.6	9.2	3.2	9.2	3.3	9.1	3.4	9.0	3.5	9.1	3.6	8.4	3.2
	-3.0	-3.7	9.7	3.3	9.6	3.4	9.5	3.5	9.5	3.5	9.1	3.4	8.4	3.1
	0.0	-0.7	10.4	3.4	10.3	3.5	9.9	3.4	9.5	3.2	9.1	3.1	8.4	2.9
	3.0	2.2	11.1	3.6	10.7	3.4	9.9	3.1	9.5	3.0	9.1	2.9	8.4	2.7
	5.0	4.1	11.4	3.5	10.7	3.2	9.9	3.0	9.5	2.9	9.1	2.7	8.4	2.5
	7.0	6.0	11.4	3.3	10.7	3.1	9.9	2.8	9.5	2.7	9.1	2.6	8.4	2.4
9.0	7.9	11.4	3.1	10.7	2.9	9.9	2.7	9.5	2.6	9.1	2.5	8.4	2.3	
11.0	9.8	11.4	2.9	10.7	2.7	9.9	2.5	9.5	2.4	9.1	2.3	8.4	2.1	
13.0	11.8	11.4	2.8	10.7	2.6	9.9	2.4	9.5	2.3	9.1	2.2	8.4	2.0	
15.0	13.7	11.4	2.6	10.7	2.4	9.9	2.2	9.5	2.2	9.1	2.1	8.4	1.9	

Abbreviations:

CR: Combination ratio

TC: Total capacity (kW)

PI: Power input (compressor + outdoor fan motor) (kW)

Notes:

Shaded cells indicate rating condition.

Table continued on next page ...

Table2-8.6:80 model heating capacity - 220-240V~50Hz (continued)

CR	Outdoor air temp.		Indoor air temp. °C DB											
			16.0		18.0		20.0		21.0		22.0		24.0	
	°C DB	°C WB	TC kW	PI kW	TC kW	PI kW	TC kW	PI kW	TC kW	PI kW	TC kW	PI kW	TC kW	PI kW
100%	-19.8	-20.0	6.0	2.6	6.0	2.7	5.9	2.8	5.9	2.8	5.8	2.9	5.8	3.0
	-18.8	-19.0	6.2	2.7	6.2	2.8	6.1	2.8	6.1	2.9	6.0	2.9	6.0	3.0
	-16.7	-17.0	6.6	2.8	6.6	2.9	6.5	2.9	6.5	3.0	6.5	3.0	6.4	3.1
	-13.7	-15.0	7.1	2.9	7.0	2.9	7.0	3.0	6.9	3.1	6.9	3.1	6.8	3.2
	-11.8	-13.0	7.5	2.9	7.5	3.0	7.4	3.1	7.4	3.2	7.3	3.2	7.2	3.3
	-9.8	-11.0	7.9	3.0	7.9	3.1	7.8	3.2	7.8	3.3	7.7	3.3	7.6	3.3
	-9.5	-10.0	8.2	3.1	8.1	3.2	8.0	3.3	8.0	3.3	8.0	3.4	7.6	3.2
	-8.5	-9.1	8.4	3.1	8.3	3.2	8.2	3.3	8.2	3.4	8.3	3.5	7.6	3.1
	-7.0	-7.6	8.7	3.2	8.6	3.3	8.6	3.4	8.7	3.5	8.3	3.3	7.6	3.0
	-5.0	-5.6	9.2	3.3	9.1	3.4	9.0	3.4	8.7	3.3	8.3	3.1	7.6	2.9
	-3.0	-3.7	9.6	3.4	9.7	3.5	9.0	3.2	8.7	3.1	8.3	3.0	7.6	2.7
	0.0	-0.7	10.4	3.5	9.7	3.2	9.0	3.0	8.7	2.9	8.3	2.8	7.6	2.6
	3.0	2.2	10.4	3.2	9.7	3.0	9.0	2.8	8.7	2.7	8.3	2.6	7.6	2.4
	5.0	4.1	10.4	3.0	9.7	2.8	9.0	2.6	8.7	2.5	8.3	2.4	7.6	2.2
	7.0	6.0	10.4	2.9	9.7	2.7	9.0	2.5	8.7	2.4	8.3	2.3	7.6	2.1
9.0	7.9	10.4	2.7	9.7	2.5	9.0	2.4	8.7	2.3	8.3	2.2	7.6	2.0	
11.0	9.8	10.4	2.6	9.7	2.4	9.0	2.2	8.7	2.1	8.3	2.1	7.6	1.9	
13.0	11.8	10.4	2.4	9.7	2.3	9.0	2.1	8.7	2.0	8.3	1.9	7.6	1.8	
15.0	13.7	10.4	2.3	9.7	2.1	9.0	2.0	8.7	1.9	8.3	1.8	7.6	1.7	
90%	-19.8	-20.0	6.0	2.7	5.9	2.7	5.9	2.8	5.8	2.9	5.8	2.9	5.7	3.0
	-18.8	-19.0	6.2	2.7	6.1	2.8	6.1	2.9	6.0	2.9	6.0	3.0	5.9	3.0
	-16.7	-17.0	6.6	2.8	6.5	2.9	6.5	3.0	6.4	3.0	6.4	3.1	6.3	3.1
	-13.7	-15.0	7.0	2.9	7.0	3.0	6.9	3.1	6.9	3.1	6.8	3.2	6.9	3.3
	-11.8	-13.0	7.4	3.0	7.4	3.1	7.3	3.2	7.3	3.2	7.2	3.3	6.9	3.1
	-9.8	-11.0	7.9	3.1	7.8	3.2	7.7	3.3	7.8	3.3	7.5	3.2	6.9	2.9
	-9.5	-10.0	8.1	3.1	8.0	3.2	8.1	3.4	7.8	3.2	7.5	3.1	6.9	2.8
	-8.5	-9.1	8.3	3.2	8.2	3.3	8.1	3.3	7.8	3.1	7.5	3.0	6.9	2.8
	-7.0	-7.6	8.6	3.2	8.7	3.4	8.1	3.1	7.8	3.0	7.5	2.9	6.9	2.7
	-5.0	-5.6	9.1	3.3	8.7	3.2	8.1	3.0	7.8	2.9	7.5	2.8	6.9	2.6
	-3.0	-3.7	9.3	3.3	8.7	3.0	8.1	2.8	7.8	2.7	7.5	2.6	6.9	2.4
	0.0	-0.7	9.3	3.0	8.7	2.8	8.1	2.6	7.8	2.5	7.5	2.4	6.9	2.3
	3.0	2.2	9.3	2.8	8.7	2.6	8.1	2.4	7.8	2.3	7.5	2.3	6.9	2.1
	5.0	4.1	9.3	2.6	8.7	2.5	8.1	2.3	7.8	2.2	7.5	2.1	6.9	2.0
	7.0	6.0	9.3	2.5	8.7	2.3	8.1	2.2	7.8	2.1	7.5	2.0	6.9	1.9
9.0	7.9	9.3	2.4	8.7	2.2	8.1	2.1	7.8	2.0	7.5	1.9	6.9	1.8	
11.0	9.8	9.3	2.2	8.7	2.1	8.1	1.9	7.8	1.9	7.5	1.8	6.9	1.7	
13.0	11.8	9.3	2.1	8.7	1.9	8.1	1.8	7.8	1.8	7.5	1.7	6.9	1.6	
15.0	13.7	9.3	2.0	8.7	1.8	8.1	1.7	7.8	1.7	7.5	1.6	6.9	1.5	
80%	-19.8	-20.0	5.9	2.7	5.9	2.8	5.8	2.9	5.7	2.9	5.7	2.9	5.6	3.0
	-18.8	-19.0	6.1	2.8	6.1	2.8	6.0	2.9	6.0	3.0	5.9	3.0	5.8	3.1
	-16.7	-17.0	6.5	2.9	6.5	2.9	6.4	3.0	6.4	3.1	6.3	3.1	6.1	3.0
	-13.7	-15.0	7.0	3.0	6.9	3.0	6.8	3.1	6.8	3.2	6.6	3.1	6.1	2.8
	-11.8	-13.0	7.4	3.1	7.3	3.1	7.2	3.2	6.9	3.0	6.6	2.9	6.1	2.7
	-9.8	-11.0	7.8	3.2	7.8	3.2	7.2	3.0	6.9	2.9	6.6	2.8	6.1	2.6
	-9.5	-10.0	8.0	3.2	7.8	3.1	7.2	2.9	6.9	2.8	6.6	2.7	6.1	2.5
	-8.5	-9.1	8.3	3.3	7.8	3.0	7.2	2.8	6.9	2.7	6.6	2.6	6.1	2.5
	-7.0	-7.6	8.3	3.1	7.8	2.9	7.2	2.7	6.9	2.6	6.6	2.5	6.1	2.4
	-5.0	-5.6	8.3	2.9	7.8	2.8	7.2	2.6	6.9	2.5	6.6	2.4	6.1	2.2
	-3.0	-3.7	8.3	2.8	7.8	2.6	7.2	2.5	6.9	2.4	6.6	2.3	6.1	2.1
	0.0	-0.7	8.3	2.6	7.8	2.4	7.2	2.3	6.9	2.2	6.6	2.1	6.1	2.0
	3.0	2.2	8.3	2.4	7.8	2.3	7.2	2.1	6.9	2.0	6.6	2.0	6.1	1.8
	5.0	4.1	8.3	2.3	7.8	2.1	7.2	2.0	6.9	1.9	6.6	1.9	6.1	1.7
	7.0	6.0	8.3	2.1	7.8	2.0	7.2	1.9	6.9	1.8	6.6	1.8	6.1	1.6
9.0	7.9	8.3	2.0	7.8	1.9	7.2	1.8	6.9	1.7	6.6	1.7	6.1	1.6	
11.0	9.8	8.3	1.9	7.8	1.8	7.2	1.7	6.9	1.6	6.6	1.6	6.1	1.5	
13.0	11.8	8.3	1.8	7.8	1.7	7.2	1.6	6.9	1.5	6.6	1.5	6.1	1.4	
15.0	13.7	8.3	1.7	7.8	1.6	7.2	1.5	6.9	1.4	6.6	1.4	6.1	1.3	

Abbreviations:

CR: Combination ratio

TC: Total capacity (kW)

PI: Power input (compressor + outdoor fan motor) (kW)

Notes:

Shaded cells indicate rating condition.

Table continued on next page ...

Table2-8.6:80 model heating capacity - 220-240V~50Hz (continued)

CR	Outdoor air temp.		Indoor air temp. °C DB											
			16.0		18.0		20.0		21.0		22.0		24.0	
	°C DB	°C WB	TC	PI	TC	PI	TC	PI	TC	PI	TC	PI	TC	PI
70%	-19.8	-20.0	5.8	2.8	5.8	2.8	5.7	2.9	5.7	3.0	5.6	3.0	5.3	2.9
	-18.8	-19.0	6.1	2.8	6.0	2.9	5.9	3.0	5.9	3.0	5.8	3.0	5.3	2.8
	-16.7	-17.0	6.5	2.9	6.4	3.0	6.3	3.0	6.1	2.9	5.8	2.8	5.3	2.6
	-13.7	-15.0	6.9	3.0	6.8	3.1	6.3	2.8	6.1	2.7	5.8	2.7	5.3	2.5
	-11.8	-13.0	7.3	3.1	6.8	2.9	6.3	2.7	6.1	2.6	5.8	2.5	5.3	2.4
	-9.8	-11.0	7.3	2.9	6.8	2.7	6.3	2.6	6.1	2.5	5.8	2.4	5.3	2.2
	-9.5	-10.0	7.3	2.8	6.8	2.7	6.3	2.5	6.1	2.4	5.8	2.3	5.3	2.2
	-8.5	-9.1	7.3	2.7	6.8	2.6	6.3	2.4	6.1	2.4	5.8	2.3	5.3	2.1
	-7.0	-7.6	7.3	2.7	6.8	2.5	6.3	2.4	6.1	2.3	5.8	2.2	5.3	2.0
	-5.0	-5.6	7.3	2.5	6.8	2.4	6.3	2.2	6.1	2.2	5.8	2.1	5.3	1.9
	-3.0	-3.7	7.3	2.4	6.8	2.3	6.3	2.1	6.1	2.1	5.8	2.0	5.3	1.9
	0.0	-0.7	7.3	2.2	6.8	2.1	6.3	2.0	6.1	1.9	5.8	1.8	5.3	1.7
	3.0	2.2	7.3	2.0	6.8	1.9	6.3	1.8	6.1	1.8	5.8	1.7	5.3	1.6
	5.0	4.1	7.3	1.9	6.8	1.8	6.3	1.7	6.1	1.7	5.8	1.6	5.3	1.5
	7.0	6.0	7.3	1.8	6.8	1.7	6.3	1.6	6.1	1.6	5.8	1.5	5.3	1.4
9.0	7.9	7.3	1.7	6.8	1.6	6.3	1.5	6.1	1.5	5.8	1.4	5.3	1.3	
11.0	9.8	7.3	1.6	6.8	1.5	6.3	1.4	6.1	1.4	5.8	1.3	5.3	1.2	
13.0	11.8	7.3	1.5	6.8	1.4	6.3	1.3	6.1	1.3	5.8	1.2	5.3	1.2	
15.0	13.7	7.3	1.4	6.8	1.3	6.3	1.3	6.1	1.2	5.8	1.2	5.3	1.1	
60%	-19.8	-20.0	5.7	2.8	5.7	2.9	5.4	2.8	5.2	2.7	5.0	2.6	4.6	2.5
	-18.8	-19.0	5.9	2.9	5.8	2.9	5.4	2.7	5.2	2.6	5.0	2.5	4.6	2.4
	-16.7	-17.0	6.2	2.9	5.8	2.7	5.4	2.5	5.2	2.5	5.0	2.4	4.6	2.2
	-13.7	-15.0	6.2	2.7	5.8	2.6	5.4	2.4	5.2	2.3	5.0	2.3	4.6	2.1
	-11.8	-13.0	6.2	2.6	5.8	2.4	5.4	2.3	5.2	2.2	5.0	2.2	4.6	2.0
	-9.8	-11.0	6.2	2.4	5.8	2.3	5.4	2.2	5.2	2.1	5.0	2.0	4.6	1.9
	-9.5	-10.0	6.2	2.4	5.8	2.3	5.4	2.1	5.2	2.1	5.0	2.0	4.6	1.9
	-8.5	-9.1	6.2	2.3	5.8	2.2	5.4	2.1	5.2	2.0	5.0	1.9	4.6	1.8
	-7.0	-7.6	6.2	2.2	5.8	2.1	5.4	2.0	5.2	1.9	5.0	1.9	4.6	1.8
	-5.0	-5.6	6.2	2.1	5.8	2.0	5.4	1.9	5.2	1.8	5.0	1.8	4.6	1.7
	-3.0	-3.7	6.2	2.0	5.8	1.9	5.4	1.8	5.2	1.8	5.0	1.7	4.6	1.6
	0.0	-0.7	6.2	1.9	5.8	1.8	5.4	1.7	5.2	1.6	5.0	1.6	4.6	1.5
	3.0	2.2	6.2	1.7	5.8	1.6	5.4	1.5	5.2	1.5	5.0	1.5	4.6	1.4
	5.0	4.1	6.2	1.6	5.8	1.5	5.4	1.5	5.2	1.4	5.0	1.4	4.6	1.3
	7.0	6.0	6.2	1.5	5.8	1.4	5.4	1.4	5.2	1.3	5.0	1.3	4.6	1.2
9.0	7.9	6.2	1.4	5.8	1.3	5.4	1.3	5.2	1.2	5.0	1.2	4.6	1.1	
11.0	9.8	6.2	1.3	5.8	1.3	5.4	1.2	5.2	1.2	5.0	1.1	4.6	1.0	
13.0	11.8	6.2	1.2	5.8	1.2	5.4	1.1	5.2	1.1	5.0	1.0	4.6	1.0	
15.0	13.7	6.2	1.2	5.8	1.1	5.4	1.0	5.2	1.0	5.0	1.0	4.6	0.9	
50%	-19.8	-20.0	5.2	2.6	4.8	2.4	4.5	2.3	4.3	2.3	4.2	2.2	3.8	2.1
	-18.8	-19.0	5.2	2.5	4.8	2.4	4.5	2.3	4.3	2.2	4.2	2.1	3.8	2.0
	-16.7	-17.0	5.2	2.4	4.8	2.2	4.5	2.1	4.3	2.1	4.2	2.0	3.8	1.9
	-13.7	-15.0	5.2	2.2	4.8	2.1	4.5	2.0	4.3	2.0	4.2	1.9	3.8	1.8
	-11.8	-13.0	5.2	2.1	4.8	2.0	4.5	1.9	4.3	1.9	4.2	1.8	3.8	1.7
	-9.8	-11.0	5.2	2.0	4.8	1.9	4.5	1.8	4.3	1.8	4.2	1.7	3.8	1.6
	-9.5	-10.0	5.2	2.0	4.8	1.9	4.5	1.8	4.3	1.7	4.2	1.7	3.8	1.6
	-8.5	-9.1	5.2	1.9	4.8	1.8	4.5	1.7	4.3	1.7	4.2	1.6	3.8	1.5
	-7.0	-7.6	5.2	1.8	4.8	1.8	4.5	1.7	4.3	1.6	4.2	1.6	3.8	1.5
	-5.0	-5.6	5.2	1.7	4.8	1.7	4.5	1.6	4.3	1.5	4.2	1.5	3.8	1.4
	-3.0	-3.7	5.2	1.7	4.8	1.6	4.5	1.5	4.3	1.5	4.2	1.4	3.8	1.4
	0.0	-0.7	5.2	1.5	4.8	1.5	4.5	1.4	4.3	1.4	4.2	1.3	3.8	1.2
	3.0	2.2	5.2	1.4	4.8	1.4	4.5	1.3	4.3	1.3	4.2	1.2	3.8	1.2
	5.0	4.1	5.2	1.3	4.8	1.3	4.5	1.2	4.3	1.2	4.2	1.2	3.8	1.1
	7.0	6.0	5.2	1.2	4.8	1.2	4.5	1.1	4.3	1.1	4.2	1.1	3.8	1.0
9.0	7.9	5.2	1.1	4.8	1.1	4.5	1.0	4.3	1.0	4.2	1.0	3.8	0.9	
11.0	9.8	5.2	1.1	4.8	1.0	4.5	1.0	4.3	0.9	4.2	0.9	3.8	0.9	
13.0	11.8	5.2	1.0	4.8	0.9	4.5	0.9	4.3	0.9	4.2	0.9	3.8	0.8	
15.0	13.7	5.2	0.9	4.8	0.9	4.5	0.9	4.3	0.8	4.2	0.8	3.8	0.8	

Abbreviations:

CR: Combination ratio

TC: Total capacity (kW)

PI: Power input (compressor + outdoor fan motor) (kW)

Notes:

Shaded cells indicate rating condition.

Table2-8.7:100 model heating capacity - 220-240V~50Hz

CR	Outdoor air temp.		Indoor air temp. °C DB											
			16.0		18.0		20.0		21.0		22.0		24.0	
	°C DB	°C WB	TC kW	PI kW	TC kW	PI kW	TC kW	PI kW	TC kW	PI kW	TC kW	PI kW	TC kW	PI kW
130%	-19.8	-20.0	6.6	2.8	6.6	3.0	6.6	3.1	6.6	3.1	6.5	3.2	6.5	3.3
	-18.8	-19.0	6.9	2.9	6.9	3.0	6.8	3.1	6.8	3.2	6.8	3.2	6.7	3.3
	-16.7	-17.0	7.3	3.0	7.3	3.1	7.3	3.2	7.3	3.3	7.2	3.3	7.2	3.4
	-13.7	-15.0	7.8	3.1	7.8	3.2	7.8	3.3	7.7	3.4	7.7	3.4	7.6	3.5
	-11.8	-13.0	8.3	3.2	8.3	3.3	8.2	3.4	8.2	3.5	8.2	3.5	8.1	3.6
	-9.8	-11.0	8.8	3.3	8.8	3.4	8.7	3.5	8.7	3.6	8.7	3.6	8.6	3.7
	-9.5	-10.0	9.0	3.3	9.0	3.4	9.0	3.5	8.9	3.6	8.9	3.7	8.8	3.8
	-8.5	-9.1	9.3	3.3	9.2	3.5	9.2	3.6	9.1	3.6	9.1	3.7	9.0	3.8
	-7.0	-7.6	9.6	3.4	9.6	3.5	9.5	3.7	9.5	3.7	9.5	3.8	9.4	3.9
	-5.0	-5.6	10.2	3.5	10.1	3.6	10.0	3.7	10.0	3.8	10.0	3.9	9.9	4.0
	-3.0	-3.7	10.7	3.6	10.6	3.7	10.5	3.8	10.5	3.9	10.5	3.9	10.4	4.1
	0.0	-0.7	11.5	3.7	11.4	3.8	11.3	4.0	11.3	4.0	11.2	4.1	11.2	4.2
	3.0	2.2	12.3	3.9	12.2	4.0	12.1	4.1	12.1	4.2	12.0	4.2	11.9	4.3
	5.0	4.1	12.8	4.0	12.7	4.1	12.6	4.2	12.6	4.3	12.6	4.3	11.9	4.0
	7.0	6.0	13.4	4.0	13.3	4.2	13.2	4.3	13.1	4.4	13.0	4.3	11.9	3.8
9.0	7.9	13.9	4.1	13.8	4.3	14.0	4.5	13.5	4.3	13.0	4.0	11.9	3.6	
11.0	9.8	14.5	4.2	14.4	4.4	14.0	4.3	13.5	4.0	13.0	3.8	11.9	3.4	
13.0	11.8	15.2	4.4	15.1	4.4	14.0	4.0	13.5	3.8	13.0	3.6	11.9	3.3	
15.0	13.7	15.8	4.5	15.1	4.2	14.0	3.8	13.5	3.6	13.0	3.4	11.9	3.1	
120%	-19.8	-20.0	6.6	2.8	6.6	3.0	6.5	3.1	6.5	3.1	6.5	3.2	6.4	3.3
	-18.8	-19.0	6.8	2.9	6.8	3.0	6.8	3.1	6.7	3.2	6.7	3.2	6.6	3.3
	-16.7	-17.0	7.3	3.0	7.3	3.1	7.2	3.2	7.2	3.3	7.2	3.3	7.1	3.4
	-13.7	-15.0	7.8	3.1	7.8	3.2	7.7	3.3	7.7	3.4	7.6	3.4	7.6	3.5
	-11.8	-13.0	8.3	3.2	8.2	3.3	8.2	3.4	8.2	3.5	8.1	3.5	8.1	3.6
	-9.8	-11.0	8.8	3.3	8.7	3.4	8.7	3.5	8.6	3.6	8.6	3.6	8.5	3.7
	-9.5	-10.0	9.0	3.3	9.0	3.4	8.9	3.5	8.9	3.6	8.8	3.7	8.8	3.8
	-8.5	-9.1	9.2	3.4	9.2	3.5	9.1	3.6	9.1	3.6	9.0	3.7	9.0	3.8
	-7.0	-7.6	9.6	3.4	9.5	3.5	9.5	3.7	9.4	3.7	9.4	3.8	9.3	3.9
	-5.0	-5.6	10.1	3.5	10.0	3.6	10.0	3.8	9.9	3.8	9.9	3.9	9.8	4.0
	-3.0	-3.7	10.6	3.6	10.5	3.7	10.5	3.8	10.4	3.9	10.4	4.0	10.3	4.1
	0.0	-0.7	11.4	3.8	11.3	3.9	11.2	4.0	11.2	4.0	11.2	4.1	11.0	4.1
	3.0	2.2	12.2	3.9	12.1	4.0	12.0	4.1	12.0	4.2	12.0	4.2	11.0	3.8
	5.0	4.1	12.7	4.0	12.6	4.1	12.5	4.2	12.5	4.2	12.0	4.0	11.0	3.6
	7.0	6.0	13.3	4.1	13.2	4.2	13.0	4.2	12.5	4.0	12.0	3.8	11.0	3.4
9.0	7.9	13.8	4.2	14.0	4.4	13.0	4.0	12.5	3.8	12.0	3.6	11.0	3.2	
11.0	9.8	14.4	4.3	14.0	4.1	13.0	3.7	12.5	3.5	12.0	3.4	11.0	3.1	
13.0	11.8	15.0	4.3	14.0	3.9	13.0	3.5	12.5	3.4	12.0	3.2	11.0	2.9	
15.0	13.7	15.0	4.0	14.0	3.7	13.0	3.3	12.5	3.2	12.0	3.0	11.0	2.8	
110%	-19.8	-20.0	6.6	2.9	6.5	3.0	6.5	3.1	6.5	3.1	6.4	3.2	6.4	3.3
	-18.8	-19.0	6.8	2.9	6.8	3.0	6.7	3.1	6.7	3.2	6.7	3.2	6.6	3.3
	-16.7	-17.0	7.3	3.0	7.2	3.1	7.2	3.2	7.2	3.3	7.1	3.3	7.1	3.4
	-13.7	-15.0	7.8	3.1	7.7	3.2	7.7	3.3	7.6	3.4	7.6	3.4	7.5	3.5
	-11.8	-13.0	8.2	3.2	8.2	3.3	8.1	3.4	8.1	3.5	8.1	3.5	8.0	3.6
	-9.8	-11.0	8.7	3.3	8.7	3.4	8.6	3.5	8.6	3.6	8.5	3.6	8.4	3.7
	-9.5	-10.0	8.9	3.3	8.9	3.5	8.8	3.6	8.8	3.6	8.8	3.7	8.7	3.8
	-8.5	-9.1	9.2	3.4	9.1	3.5	9.0	3.6	9.0	3.7	9.0	3.7	8.9	3.8
	-7.0	-7.6	9.5	3.5	9.5	3.6	9.4	3.7	9.4	3.7	9.3	3.8	9.3	3.9
	-5.0	-5.6	10.0	3.6	10.0	3.7	9.9	3.8	9.9	3.8	9.8	3.9	9.7	4.0
	-3.0	-3.7	10.5	3.6	10.5	3.8	10.4	3.9	10.3	3.9	10.3	4.0	10.1	3.9
	0.0	-0.7	11.3	3.8	11.2	3.9	11.2	4.0	11.1	4.1	11.0	4.0	10.1	3.6
	3.0	2.2	12.1	3.9	12.0	4.1	11.9	4.1	11.4	3.9	11.0	3.7	10.1	3.3
	5.0	4.1	12.6	4.0	12.8	4.2	11.9	3.9	11.4	3.7	11.0	3.5	10.1	3.2
	7.0	6.0	13.2	4.1	12.8	4.0	11.9	3.6	11.4	3.5	11.0	3.3	10.1	3.0
9.0	7.9	13.7	4.1	12.8	3.8	11.9	3.4	11.4	3.3	11.0	3.2	10.1	2.9	
11.0	9.8	13.7	3.9	12.8	3.6	11.9	3.3	11.4	3.1	11.0	3.0	10.1	2.7	
13.0	11.8	13.7	3.7	12.8	3.4	11.9	3.1	11.4	3.0	11.0	2.8	10.1	2.6	
15.0	13.7	13.7	3.5	12.8	3.2	11.9	2.9	11.4	2.8	11.0	2.7	10.1	2.4	

Abbreviations:

CR: Combination ratio

TC: Total capacity (kW)

PI: Power input (compressor + outdoor fan motor) (kW)

Notes:

Shaded cells indicate rating condition.

Table continued on next page ...

Table2-8.7:100 model heating capacity - 220-240V~50Hz (continued)

CR	Outdoor air temp.		Indoor air temp. °C DB											
			16.0		18.0		20.0		21.0		22.0		24.0	
	°C DB	°C WB	TC	PI	TC	PI	TC	PI	TC	PI	TC	PI	TC	PI
100%	-19.8	-20.0	6.5	2.9	6.5	3.0	6.5	3.1	6.4	3.1	6.4	3.2	6.3	3.3
	-18.8	-19.0	6.8	2.9	6.7	3.0	6.7	3.1	6.7	3.2	6.6	3.2	6.5	3.3
	-16.7	-17.0	7.2	3.0	7.2	3.1	7.1	3.2	7.1	3.3	7.1	3.3	7.0	3.4
	-13.7	-15.0	7.7	3.1	7.7	3.2	7.6	3.3	7.6	3.4	7.5	3.4	7.5	3.5
	-11.8	-13.0	8.2	3.2	8.1	3.3	8.1	3.4	8.0	3.5	8.0	3.5	7.9	3.6
	-9.8	-11.0	8.6	3.3	8.6	3.4	8.5	3.5	8.5	3.6	8.5	3.6	8.4	3.7
	-9.5	-10.0	8.9	3.4	8.8	3.5	8.8	3.6	8.7	3.6	8.7	3.7	8.6	3.8
	-8.5	-9.1	9.1	3.4	9.0	3.5	9.0	3.6	8.9	3.7	8.9	3.7	8.8	3.9
	-7.0	-7.6	9.5	3.5	9.4	3.6	9.3	3.7	9.3	3.8	9.3	3.8	9.1	3.9
	-5.0	-5.6	10.0	3.6	9.9	3.7	9.8	3.8	9.8	3.9	9.7	3.9	9.1	3.6
	-3.0	-3.7	10.4	3.7	10.4	3.8	10.3	3.9	10.4	4.0	10.0	3.8	9.1	3.4
	0.0	-0.7	11.2	3.8	11.1	4.0	10.8	3.9	10.4	3.7	10.0	3.5	9.1	3.2
	3.0	2.2	12.0	4.0	11.6	3.9	10.8	3.5	10.4	3.4	10.0	3.2	9.1	3.0
	5.0	4.1	12.5	4.0	11.6	3.7	10.8	3.3	10.4	3.2	10.0	3.1	9.1	2.8
	7.0	6.0	12.5	3.8	11.6	3.5	10.8	3.2	10.4	3.1	10.0	2.9	9.1	2.7
9.0	7.9	12.5	3.6	11.6	3.3	10.8	3.0	10.4	2.9	10.0	2.8	9.1	2.6	
11.0	9.8	12.5	3.4	11.6	3.1	10.8	2.9	10.4	2.8	10.0	2.6	9.1	2.4	
13.0	11.8	12.5	3.2	11.6	2.9	10.8	2.7	10.4	2.6	10.0	2.5	9.1	2.3	
15.0	13.7	12.5	3.0	11.6	2.8	10.8	2.6	10.4	2.5	10.0	2.3	9.1	2.1	
90%	-19.8	-20.0	6.5	2.9	6.5	3.0	6.4	3.1	6.4	3.1	6.3	3.2	6.2	3.3
	-18.8	-19.0	6.7	3.0	6.7	3.1	6.6	3.2	6.6	3.2	6.6	3.2	6.5	3.3
	-16.7	-17.0	7.2	3.1	7.1	3.2	7.1	3.3	7.0	3.3	7.0	3.4	6.9	3.4
	-13.7	-15.0	7.6	3.2	7.6	3.3	7.5	3.4	7.5	3.4	7.5	3.5	7.4	3.6
	-11.8	-13.0	8.1	3.3	8.1	3.4	8.0	3.5	7.9	3.5	7.9	3.6	7.8	3.7
	-9.8	-11.0	8.6	3.4	8.5	3.5	8.4	3.6	8.4	3.6	8.4	3.7	8.2	3.7
	-9.5	-10.0	8.8	3.4	8.7	3.5	8.7	3.6	8.6	3.7	8.6	3.7	8.2	3.6
	-8.5	-9.1	9.0	3.5	9.0	3.6	8.9	3.7	8.9	3.7	9.0	3.9	8.2	3.5
	-7.0	-7.6	9.4	3.6	9.3	3.7	9.2	3.8	9.3	3.9	9.0	3.7	8.2	3.3
	-5.0	-5.6	9.9	3.7	9.8	3.8	9.7	3.8	9.3	3.6	9.0	3.5	8.2	3.1
	-3.0	-3.7	10.4	3.8	10.5	3.9	9.7	3.6	9.3	3.4	9.0	3.3	8.2	3.0
	0.0	-0.7	11.2	3.9	10.5	3.6	9.7	3.3	9.3	3.2	9.0	3.0	8.2	2.8
	3.0	2.2	11.2	3.6	10.5	3.3	9.7	3.1	9.3	2.9	9.0	2.8	8.2	2.6
	5.0	4.1	11.2	3.4	10.5	3.1	9.7	2.9	9.3	2.8	9.0	2.7	8.2	2.5
	7.0	6.0	11.2	3.2	10.5	3.0	9.7	2.8	9.3	2.7	9.0	2.6	8.2	2.3
9.0	7.9	11.2	3.0	10.5	2.8	9.7	2.6	9.3	2.5	9.0	2.4	8.2	2.2	
11.0	9.8	11.2	2.9	10.5	2.7	9.7	2.5	9.3	2.4	9.0	2.3	8.2	2.1	
13.0	11.8	11.2	2.7	10.5	2.5	9.7	2.3	9.3	2.2	9.0	2.1	8.2	2.0	
15.0	13.7	11.2	2.6	10.5	2.4	9.7	2.2	9.3	2.1	9.0	2.0	8.2	1.9	
80%	-19.8	-20.0	6.4	2.9	6.4	3.0	6.3	3.1	6.3	3.2	6.3	3.2	6.2	3.3
	-18.8	-19.0	6.7	3.0	6.6	3.1	6.5	3.2	6.5	3.2	6.5	3.3	6.4	3.4
	-16.7	-17.0	7.1	3.1	7.1	3.2	7.0	3.3	7.0	3.3	6.9	3.4	6.8	3.5
	-13.7	-15.0	7.6	3.2	7.5	3.3	7.4	3.4	7.4	3.5	7.4	3.5	7.3	3.6
	-11.8	-13.0	8.0	3.3	8.0	3.4	7.9	3.5	7.9	3.6	8.0	3.7	7.3	3.4
	-9.8	-11.0	8.5	3.4	8.4	3.5	8.4	3.6	8.3	3.6	8.0	3.5	7.3	3.1
	-9.5	-10.0	8.7	3.5	8.7	3.6	8.6	3.7	8.3	3.5	8.0	3.4	7.3	3.0
	-8.5	-9.1	8.9	3.5	8.9	3.6	8.6	3.6	8.3	3.4	8.0	3.3	7.3	3.0
	-7.0	-7.6	9.3	3.6	9.3	3.7	8.6	3.4	8.3	3.3	8.0	3.1	7.3	2.9
	-5.0	-5.6	10.0	3.8	9.3	3.5	8.6	3.2	8.3	3.1	8.0	3.0	7.3	2.7
	-3.0	-3.7	10.0	3.6	9.3	3.3	8.6	3.1	8.3	2.9	8.0	2.8	7.3	2.6
	0.0	-0.7	10.0	3.3	9.3	3.0	8.6	2.8	8.3	2.7	8.0	2.6	7.3	2.4
	3.0	2.2	10.0	3.0	9.3	2.8	8.6	2.6	8.3	2.5	8.0	2.4	7.3	2.3
	5.0	4.1	10.0	2.9	9.3	2.7	8.6	2.5	8.3	2.4	8.0	2.3	7.3	2.1
	7.0	6.0	10.0	2.7	9.3	2.6	8.6	2.4	8.3	2.3	8.0	2.2	7.3	2.0
9.0	7.9	10.0	2.6	9.3	2.4	8.6	2.3	8.3	2.2	8.0	2.1	7.3	1.9	
11.0	9.8	10.0	2.5	9.3	2.3	8.6	2.1	8.3	2.0	8.0	2.0	7.3	1.8	
13.0	11.8	10.0	2.3	9.3	2.2	8.6	2.0	8.3	1.9	8.0	1.9	7.3	1.7	
15.0	13.7	10.0	2.2	9.3	2.0	8.6	1.9	8.3	1.8	8.0	1.7	7.3	1.6	

Abbreviations:

CR: Combination ratio

TC: Total capacity (kW)

PI: Power input (compressor + outdoor fan motor) (kW)

Notes:

Shaded cells indicate rating condition.

Table continued on next page ...

Table2-8.7:100 model heating capacity - 220-240V~50Hz (continued)

CR	Outdoor air temp.		Indoor air temp. °C DB											
			16.0		18.0		20.0		21.0		22.0		24.0	
	°C DB	°C WB	TC	PI	TC	PI	TC	PI	TC	PI	TC	PI	TC	PI
70%	-19.8	-20.0	6.4	3.0	6.3	3.1	6.2	3.2	6.2	3.2	6.2	3.3	6.0	3.3
	-18.8	-19.0	6.6	3.1	6.5	3.2	6.5	3.2	6.4	3.3	6.4	3.3	6.4	3.5
	-16.7	-17.0	7.0	3.2	7.0	3.3	6.9	3.4	6.9	3.4	6.8	3.5	6.4	3.2
	-13.7	-15.0	7.5	3.3	7.4	3.4	7.3	3.5	7.3	3.5	7.0	3.3	6.4	3.0
	-11.8	-13.0	7.9	3.4	7.9	3.5	7.6	3.4	7.3	3.2	7.0	3.1	6.4	2.8
	-9.8	-11.0	8.4	3.5	8.1	3.4	7.6	3.2	7.3	3.0	7.0	2.9	6.4	2.7
	-9.5	-10.0	8.7	3.6	8.1	3.3	7.6	3.1	7.3	2.9	7.0	2.8	6.4	2.6
	-8.5	-9.1	8.7	3.5	8.1	3.2	7.6	3.0	7.3	2.9	7.0	2.8	6.4	2.6
	-7.0	-7.6	8.7	3.3	8.1	3.1	7.6	2.9	7.3	2.8	7.0	2.7	6.4	2.5
	-5.0	-5.6	8.7	3.1	8.1	2.9	7.6	2.7	7.3	2.6	7.0	2.6	6.4	2.4
	-3.0	-3.7	8.7	3.0	8.1	2.8	7.6	2.6	7.3	2.5	7.0	2.4	6.4	2.3
	0.0	-0.7	8.7	2.8	8.1	2.6	7.6	2.4	7.3	2.3	7.0	2.3	6.4	2.1
	3.0	2.2	8.7	2.6	8.1	2.4	7.6	2.2	7.3	2.2	7.0	2.1	6.4	1.9
	5.0	4.1	8.7	2.4	8.1	2.3	7.6	2.1	7.3	2.0	7.0	2.0	6.4	1.8
	7.0	6.0	8.7	2.3	8.1	2.1	7.6	2.0	7.3	1.9	7.0	1.9	6.4	1.7
9.0	7.9	8.7	2.2	8.1	2.0	7.6	1.9	7.3	1.8	7.0	1.8	6.4	1.7	
11.0	9.8	8.7	2.0	8.1	1.9	7.6	1.8	7.3	1.7	7.0	1.7	6.4	1.6	
13.0	11.8	8.7	1.9	8.1	1.8	7.6	1.7	7.3	1.6	7.0	1.6	6.4	1.5	
15.0	13.7	8.7	1.8	8.1	1.7	7.6	1.6	7.3	1.5	7.0	1.5	6.4	1.4	
60%	-19.8	-20.0	6.3	3.1	6.2	3.2	6.1	3.3	6.1	3.3	6.0	3.2	5.5	3.0
	-18.8	-19.0	6.5	3.1	6.4	3.2	6.5	3.4	6.2	3.3	6.0	3.1	5.5	2.9
	-16.7	-17.0	6.9	3.3	7.0	3.4	6.5	3.2	6.2	3.0	6.0	2.9	5.5	2.7
	-13.7	-15.0	7.5	3.4	7.0	3.2	6.5	2.9	6.2	2.8	6.0	2.7	5.5	2.5
	-11.8	-13.0	7.5	3.2	7.0	3.0	6.5	2.8	6.2	2.7	6.0	2.6	5.5	2.4
	-9.8	-11.0	7.5	3.0	7.0	2.8	6.5	2.6	6.2	2.6	6.0	2.5	5.5	2.3
	-9.5	-10.0	7.5	2.9	7.0	2.7	6.5	2.6	6.2	2.5	6.0	2.4	5.5	2.2
	-8.5	-9.1	7.5	2.8	7.0	2.7	6.5	2.5	6.2	2.4	6.0	2.4	5.5	2.2
	-7.0	-7.6	7.5	2.7	7.0	2.6	6.5	2.4	6.2	2.3	6.0	2.3	5.5	2.1
	-5.0	-5.6	7.5	2.6	7.0	2.5	6.5	2.3	6.2	2.2	6.0	2.2	5.5	2.0
	-3.0	-3.7	7.5	2.5	7.0	2.3	6.5	2.2	6.2	2.1	6.0	2.1	5.5	1.9
	0.0	-0.7	7.5	2.3	7.0	2.2	6.5	2.0	6.2	2.0	6.0	1.9	5.5	1.8
	3.0	2.2	7.5	2.1	7.0	2.0	6.5	1.9	6.2	1.8	6.0	1.8	5.5	1.7
	5.0	4.1	7.5	2.0	7.0	1.9	6.5	1.8	6.2	1.7	6.0	1.7	5.5	1.6
	7.0	6.0	7.5	1.9	7.0	1.8	6.5	1.7	6.2	1.6	6.0	1.6	5.5	1.5
9.0	7.9	7.5	1.8	7.0	1.7	6.5	1.6	6.2	1.5	6.0	1.5	5.5	1.4	
11.0	9.8	7.5	1.7	7.0	1.6	6.5	1.5	6.2	1.4	6.0	1.4	5.5	1.3	
13.0	11.8	7.5	1.6	7.0	1.5	6.5	1.4	6.2	1.3	6.0	1.3	5.5	1.2	
15.0	13.7	7.5	1.5	7.0	1.4	6.5	1.3	6.2	1.3	6.0	1.2	5.5	1.1	
50%	-19.8	-20.0	6.2	3.2	5.8	3.0	5.4	2.8	5.2	2.7	5.0	2.6	4.6	2.4
	-18.8	-19.0	6.2	3.1	5.8	2.9	5.4	2.7	5.2	2.6	5.0	2.5	4.6	2.4
	-16.7	-17.0	6.2	2.9	5.8	2.7	5.4	2.5	5.2	2.5	5.0	2.4	4.6	2.2
	-13.7	-15.0	6.2	2.7	5.8	2.6	5.4	2.4	5.2	2.3	5.0	2.3	4.6	2.1
	-11.8	-13.0	6.2	2.6	5.8	2.4	5.4	2.3	5.2	2.2	5.0	2.2	4.6	2.0
	-9.8	-11.0	6.2	2.4	5.8	2.3	5.4	2.2	5.2	2.1	5.0	2.0	4.6	1.9
	-9.5	-10.0	6.2	2.4	5.8	2.3	5.4	2.1	5.2	2.1	5.0	2.0	4.6	1.9
	-8.5	-9.1	6.2	2.3	5.8	2.2	5.4	2.1	5.2	2.0	5.0	1.9	4.6	1.8
	-7.0	-7.6	6.2	2.2	5.8	2.1	5.4	2.0	5.2	1.9	5.0	1.9	4.6	1.8
	-5.0	-5.6	6.2	2.1	5.8	2.0	5.4	1.9	5.2	1.8	5.0	1.8	4.6	1.7
	-3.0	-3.7	6.2	2.0	5.8	1.9	5.4	1.8	5.2	1.8	5.0	1.7	4.6	1.6
	0.0	-0.7	6.2	1.9	5.8	1.8	5.4	1.7	5.2	1.6	5.0	1.6	4.6	1.5
	3.0	2.2	6.2	1.7	5.8	1.6	5.4	1.6	5.2	1.5	5.0	1.5	4.6	1.4
	5.0	4.1	6.2	1.6	5.8	1.6	5.4	1.5	5.2	1.4	5.0	1.4	4.6	1.3
	7.0	6.0	6.2	1.5	5.8	1.4	5.4	1.4	5.2	1.3	5.0	1.3	4.6	1.2
9.0	7.9	6.2	1.4	5.8	1.4	5.4	1.3	5.2	1.2	5.0	1.2	4.6	1.1	
11.0	9.8	6.2	1.3	5.8	1.3	5.4	1.2	5.2	1.2	5.0	1.1	4.6	1.0	
13.0	11.8	6.2	1.3	5.8	1.2	5.4	1.1	5.2	1.1	5.0	1.0	4.6	1.0	
15.0	13.7	6.2	1.2	5.8	1.1	5.4	1.1	5.2	1.0	5.0	1.0	4.6	0.9	

Abbreviations:

CR: Combination ratio

TC: Total capacity (kW)

PI: Power input (compressor + outdoor fan motor) (kW)

Notes:

Shaded cells indicate rating condition.

Table2-8.8:120 model heating capacity - 220-240V~50Hz

CR	Outdoor air temp.		Indoor air temp. °C DB											
			16.0		18.0		20.0		21.0		22.0		24.0	
	°C DB	°C WB	TC	PI	TC	PI	TC	PI	TC	PI	TC	PI	TC	PI
130%	-19.8	-20.0	10.2	4.5	10.1	4.5	10.1	4.6	10.1	4.6	10.0	4.6	10.0	4.7
	-18.8	-19.0	10.6	4.5	10.5	4.5	10.4	4.6	10.4	4.6	10.4	4.7	10.3	4.8
	-16.7	-17.0	11.2	4.5	11.1	4.6	11.1	4.7	11.0	4.7	11.0	4.8	11.0	4.9
	-13.7	-15.0	11.9	4.6	11.8	4.7	11.7	4.7	11.7	4.8	11.7	4.8	11.6	5.0
	-11.8	-13.0	12.6	4.7	12.5	4.7	12.4	4.8	12.4	4.9	12.3	5.0	12.3	5.1
	-9.8	-11.0	13.3	4.7	13.2	4.8	13.1	4.9	13.1	5.0	13.0	5.1	13.0	5.2
	-9.5	-10.0	13.7	4.8	13.6	4.9	13.5	5.0	13.4	5.1	13.4	5.1	13.3	5.3
	-8.5	-9.1	14.0	4.8	13.9	4.9	13.8	5.1	13.7	5.1	13.7	5.2	13.6	5.3
	-7.0	-7.6	14.5	4.9	14.4	5.0	14.3	5.1	14.3	5.2	14.2	5.3	14.2	5.4
	-5.0	-5.6	15.3	5.0	15.2	5.1	15.0	5.3	15.0	5.4	15.0	5.4	14.9	5.6
	-3.0	-3.7	16.0	5.1	15.9	5.3	15.8	5.4	15.7	5.5	15.7	5.6	15.4	5.6
	0.0	-0.7	17.2	5.3	17.0	5.5	16.9	5.6	16.9	5.7	16.8	5.7	15.4	5.2
	3.0	2.2	18.3	5.5	18.2	5.7	18.2	5.9	17.5	5.6	16.8	5.3	15.4	4.8
	5.0	4.1	19.1	5.7	18.8	5.7	18.2	5.6	17.5	5.3	16.8	5.1	15.4	4.6
	7.0	6.0	19.7	5.7	19.6	5.8	18.2	5.3	17.5	5.1	16.8	4.8	15.4	4.3
9.0	7.9	20.3	5.7	19.6	5.5	18.2	5.1	17.5	4.8	16.8	4.6	15.4	4.1	
11.0	9.8	21.0	5.8	19.6	5.3	18.2	4.8	17.5	4.6	16.8	4.3	15.4	3.9	
13.0	11.8	21.0	5.4	19.6	5.0	18.2	4.5	17.5	4.3	16.8	4.1	15.4	3.7	
15.0	13.7	21.0	5.2	19.6	4.7	18.2	4.3	17.5	4.0	16.8	3.8	15.4	3.5	
120%	-19.8	-20.0	10.2	4.5	10.1	4.5	10.0	4.6	10.0	4.6	10.0	4.7	10.0	4.8
	-18.8	-19.0	10.5	4.5	10.4	4.6	10.4	4.6	10.3	4.7	10.3	4.7	10.3	4.8
	-16.7	-17.0	11.1	4.6	11.1	4.6	11.0	4.7	11.0	4.8	11.0	4.8	10.9	4.9
	-13.7	-15.0	11.8	4.6	11.7	4.7	11.7	4.8	11.6	4.9	11.6	4.9	11.6	5.0
	-11.8	-13.0	12.5	4.7	12.4	4.8	12.3	4.9	12.3	5.0	12.3	5.0	12.2	5.2
	-9.8	-11.0	13.2	4.8	13.1	4.9	13.0	5.0	13.0	5.1	12.9	5.1	12.9	5.3
	-9.5	-10.0	13.5	4.8	13.4	5.0	13.4	5.1	13.3	5.1	13.3	5.2	13.2	5.4
	-8.5	-9.1	13.9	4.9	13.8	5.0	13.7	5.1	13.6	5.2	13.6	5.3	13.5	5.4
	-7.0	-7.6	14.4	5.0	14.3	5.1	14.2	5.2	14.2	5.3	14.1	5.4	14.2	5.6
	-5.0	-5.6	15.1	5.1	15.0	5.2	14.9	5.4	14.9	5.5	14.8	5.5	14.2	5.3
	-3.0	-3.7	15.9	5.2	15.7	5.4	15.6	5.5	15.6	5.6	15.5	5.6	14.2	5.1
	0.0	-0.7	17.0	5.4	16.9	5.6	16.8	5.7	16.2	5.5	15.5	5.2	14.2	4.7
	3.0	2.2	18.2	5.7	18.1	5.8	16.8	5.3	16.2	5.1	15.5	4.8	14.2	4.4
	5.0	4.1	18.8	5.7	18.1	5.5	16.8	5.0	16.2	4.8	15.5	4.6	14.2	4.1
	7.0	6.0	19.4	5.7	18.1	5.2	16.8	4.8	16.2	4.6	15.5	4.4	14.2	3.9
9.0	7.9	19.4	5.4	18.1	5.0	16.8	4.5	16.2	4.3	15.5	4.1	14.2	3.7	
11.0	9.8	19.4	5.1	18.1	4.7	16.8	4.3	16.2	4.1	15.5	3.9	14.2	3.5	
13.0	11.8	19.4	4.8	18.1	4.4	16.8	4.0	16.2	3.8	15.5	3.7	14.2	3.3	
15.0	13.7	19.4	4.6	18.1	4.2	16.8	3.8	16.2	3.6	15.5	3.4	14.2	3.1	
110%	-19.8	-20.0	10.1	4.5	10.0	4.6	10.0	4.6	10.0	4.7	10.0	4.7	10.0	4.8
	-18.8	-19.0	10.4	4.5	10.3	4.6	10.3	4.7	10.3	4.7	10.3	4.8	10.3	4.9
	-16.7	-17.0	11.0	4.6	11.0	4.7	10.9	4.8	10.9	4.8	10.9	4.9	10.9	5.0
	-13.7	-15.0	11.7	4.7	11.6	4.8	11.6	4.9	11.6	4.9	11.5	5.0	11.5	5.1
	-11.8	-13.0	12.4	4.8	12.3	4.9	12.2	5.0	12.2	5.0	12.2	5.1	12.2	5.3
	-9.8	-11.0	13.1	4.9	13.0	5.0	12.9	5.1	12.9	5.2	12.9	5.2	13.0	5.5
	-9.5	-10.0	13.4	4.9	13.3	5.0	13.3	5.2	13.2	5.2	13.2	5.3	13.0	5.4
	-8.5	-9.1	13.7	5.0	13.6	5.1	13.6	5.2	13.5	5.3	13.5	5.4	13.0	5.2
	-7.0	-7.6	14.3	5.1	14.2	5.2	14.1	5.3	14.1	5.4	14.2	5.6	13.0	5.1
	-5.0	-5.6	15.0	5.2	14.9	5.3	14.8	5.5	14.8	5.5	14.2	5.3	13.0	4.8
	-3.0	-3.7	15.7	5.3	15.6	5.5	15.4	5.5	14.8	5.3	14.2	5.1	13.0	4.6
	0.0	-0.7	16.9	5.6	16.6	5.6	15.4	5.1	14.8	4.9	14.2	4.7	13.0	4.3
	3.0	2.2	17.8	5.6	16.6	5.2	15.4	4.7	14.8	4.5	14.2	4.3	13.0	3.9
	5.0	4.1	17.8	5.3	16.6	4.9	15.4	4.5	14.8	4.3	14.2	4.1	13.0	3.7
	7.0	6.0	17.8	5.1	16.6	4.7	15.4	4.3	14.8	4.1	14.2	3.9	13.0	3.5
9.0	7.9	17.8	4.8	16.6	4.4	15.4	4.0	14.8	3.9	14.2	3.7	13.0	3.4	
11.0	9.8	17.8	4.5	16.6	4.2	15.4	3.8	14.8	3.6	14.2	3.5	13.0	3.2	
13.0	11.8	17.8	4.3	16.6	3.9	15.4	3.6	14.8	3.4	14.2	3.3	13.0	3.0	
15.0	13.7	17.8	4.0	16.6	3.7	15.4	3.4	14.8	3.2	14.2	3.1	13.0	2.8	

Abbreviations:

CR: Combination ratio

TC: Total capacity (kW)

PI: Power input (compressor + outdoor fan motor) (kW)

Notes:

Shaded cells indicate rating condition.

Table continued on next page ...

Table2-8.8:120 model heating capacity - 220-240V~50Hz (continued)

CR	Outdoor air temp.		Indoor air temp. °C DB											
			16.0		18.0		20.0		21.0		22.0		24.0	
	°C DB	°C WB	TC	PI	TC	PI	TC	PI	TC	PI	TC	PI	TC	PI
100%	-19.8	-20.0	10.0	4.6	10.0	4.6	9.9	4.7	9.9	4.7	9.9	4.8	10.0	4.9
	-18.8	-19.0	10.3	4.6	10.3	4.6	10.2	4.7	10.2	4.8	10.2	4.8	10.3	5.0
	-16.7	-17.0	11.0	4.7	10.9	4.7	10.9	4.8	10.9	4.9	10.9	4.9	10.9	5.1
	-13.7	-15.0	11.6	4.7	11.5	4.8	11.5	4.9	11.5	5.0	11.5	5.1	11.5	5.2
	-11.8	-13.0	12.3	4.8	12.2	4.9	12.2	5.1	12.1	5.1	12.1	5.2	11.8	5.2
	-9.8	-11.0	13.0	5.0	12.9	5.1	12.8	5.2	12.8	5.3	12.9	5.4	11.8	4.9
	-9.5	-10.0	13.3	5.0	13.2	5.1	13.2	5.3	13.1	5.4	12.9	5.3	11.8	4.8
	-8.5	-9.1	13.6	5.1	13.5	5.2	13.5	5.4	13.5	5.4	12.9	5.2	11.8	4.7
	-7.0	-7.6	14.1	5.2	14.1	5.3	14.0	5.4	13.5	5.2	12.9	5.0	11.8	4.5
	-5.0	-5.6	14.9	5.3	15.1	5.6	14.0	5.2	13.5	5.0	12.9	4.7	11.8	4.3
	-3.0	-3.7	15.6	5.5	15.1	5.3	14.0	4.9	13.5	4.7	12.9	4.5	11.8	4.1
	0.0	-0.7	16.2	5.3	15.1	5.0	14.0	4.6	13.5	4.4	12.9	4.2	11.8	3.8
	3.0	2.2	16.2	5.0	15.1	4.6	14.0	4.2	13.5	4.0	12.9	3.9	11.8	3.5
	5.0	4.1	16.2	4.7	15.1	4.4	14.0	4.0	13.5	3.8	12.9	3.7	11.8	3.3
	7.0	6.0	16.2	4.5	15.1	4.1	14.0	3.8	13.5	3.6	12.9	3.5	11.8	3.2
9.0	7.9	16.2	4.2	15.1	3.9	14.0	3.6	13.5	3.4	12.9	3.3	11.8	3.0	
11.0	9.8	16.2	4.0	15.1	3.7	14.0	3.4	13.5	3.2	12.9	3.1	11.8	2.8	
13.0	11.8	16.2	3.7	15.1	3.5	14.0	3.2	13.5	3.0	12.9	2.9	11.8	2.7	
15.0	13.7	16.2	3.5	15.1	3.3	14.0	3.0	13.5	2.9	12.9	2.8	11.8	2.5	
90%	-19.8	-20.0	9.9	4.6	9.9	4.7	9.9	4.8	9.9	4.8	9.9	4.9	10.0	5.0
	-18.8	-19.0	10.2	4.6	10.2	4.7	10.2	4.8	10.2	4.9	10.2	4.9	10.3	5.1
	-16.7	-17.0	10.9	4.7	10.8	4.8	10.8	4.9	10.8	5.0	10.8	5.1	10.7	5.1
	-13.7	-15.0	11.5	4.8	11.5	4.9	11.4	5.1	11.4	5.1	11.6	5.3	10.7	4.8
	-11.8	-13.0	12.2	4.9	12.1	5.1	12.1	5.2	12.1	5.3	11.6	5.0	10.7	4.6
	-9.8	-11.0	12.8	5.1	12.8	5.2	12.6	5.2	12.1	5.0	11.6	4.8	10.7	4.4
	-9.5	-10.0	13.2	5.1	13.1	5.3	12.6	5.1	12.1	4.9	11.6	4.7	10.7	4.3
	-8.5	-9.1	13.5	5.2	13.6	5.4	12.6	5.0	12.1	4.8	11.6	4.6	10.7	4.2
	-7.0	-7.6	14.0	5.3	13.6	5.2	12.6	4.8	12.1	4.6	11.6	4.4	10.7	4.1
	-5.0	-5.6	14.5	5.3	13.6	4.9	12.6	4.6	12.1	4.4	11.6	4.2	10.7	3.8
	-3.0	-3.7	14.5	5.1	13.6	4.7	12.6	4.4	12.1	4.2	11.6	4.0	10.7	3.7
	0.0	-0.7	14.5	4.7	13.6	4.4	12.6	4.0	12.1	3.9	11.6	3.7	10.7	3.4
	3.0	2.2	14.5	4.3	13.6	4.0	12.6	3.7	12.1	3.6	11.6	3.4	10.7	3.1
	5.0	4.1	14.5	4.1	13.6	3.8	12.6	3.5	12.1	3.4	11.6	3.2	10.7	3.0
	7.0	6.0	14.5	3.9	13.6	3.6	12.6	3.3	12.1	3.2	11.6	3.1	10.7	2.8
9.0	7.9	14.5	3.7	13.6	3.4	12.6	3.2	12.1	3.0	11.6	2.9	10.7	2.7	
11.0	9.8	14.5	3.5	13.6	3.2	12.6	3.0	12.1	2.9	11.6	2.7	10.7	2.5	
13.0	11.8	14.5	3.3	13.6	3.0	12.6	2.8	12.1	2.7	11.6	2.6	10.7	2.3	
15.0	13.7	14.5	3.1	13.6	2.8	12.6	2.6	12.1	2.5	11.6	2.4	10.7	2.2	
80%	-19.8	-20.0	9.9	4.7	9.9	4.8	9.9	4.9	9.9	4.9	9.9	5.0	9.5	4.8
	-18.8	-19.0	10.2	4.7	10.2	4.8	10.2	4.9	10.2	5.0	10.3	5.1	9.5	4.7
	-16.7	-17.0	10.8	4.8	10.8	4.9	10.8	5.1	10.8	5.1	10.3	4.9	9.5	4.5
	-13.7	-15.0	11.4	4.9	11.4	5.1	11.2	5.0	10.8	4.9	10.3	4.7	9.5	4.3
	-11.8	-13.0	12.1	5.1	12.1	5.2	11.2	4.8	10.8	4.6	10.3	4.4	9.5	4.1
	-9.8	-11.0	12.9	5.3	12.1	4.9	11.2	4.6	10.8	4.4	10.3	4.2	9.5	3.9
	-9.5	-10.0	12.9	5.2	12.1	4.8	11.2	4.5	10.8	4.3	10.3	4.1	9.5	3.8
	-8.5	-9.1	12.9	5.1	12.1	4.7	11.2	4.4	10.8	4.2	10.3	4.0	9.5	3.7
	-7.0	-7.6	12.9	4.9	12.1	4.5	11.2	4.2	10.8	4.0	10.3	3.9	9.5	3.6
	-5.0	-5.6	12.9	4.6	12.1	4.3	11.2	4.0	10.8	3.8	10.3	3.7	9.5	3.4
	-3.0	-3.7	12.9	4.4	12.1	4.1	11.2	3.8	10.8	3.7	10.3	3.5	9.5	3.2
	0.0	-0.7	12.9	4.1	12.1	3.8	11.2	3.5	10.8	3.4	10.3	3.2	9.5	3.0
	3.0	2.2	12.9	3.8	12.1	3.5	11.2	3.2	10.8	3.1	10.3	3.0	9.5	2.7
	5.0	4.1	12.9	3.5	12.1	3.3	11.2	3.1	10.8	2.9	10.3	2.8	9.5	2.6
	7.0	6.0	12.9	3.4	12.1	3.1	11.2	2.9	10.8	2.8	10.3	2.7	9.5	2.5
9.0	7.9	12.9	3.2	12.1	3.0	11.2	2.7	10.8	2.6	10.3	2.5	9.5	2.3	
11.0	9.8	12.9	3.0	12.1	2.8	11.2	2.6	10.8	2.5	10.3	2.4	9.5	2.2	
13.0	11.8	12.9	2.8	12.1	2.6	11.2	2.4	10.8	2.3	10.3	2.2	9.5	2.0	
15.0	13.7	12.9	2.7	12.1	2.5	11.2	2.3	10.8	2.2	10.3	2.1	9.5	1.9	

Abbreviations:

CR: Combination ratio

TC: Total capacity (kW)

PI: Power input (compressor + outdoor fan motor) (kW)

Notes:

Shaded cells indicate rating condition.

Table continued on next page ...

Table2-8.8:120 model heating capacity - 220-240V~50Hz (continued)

CR	Outdoor air temp.		Indoor air temp. °C DB											
			16.0		18.0		20.0		21.0		22.0		24.0	
	°C DB	°C WB	TC	PI	TC	PI	TC	PI	TC	PI	TC	PI	TC	PI
70%	-19.8	-20.0	9.8	4.8	9.9	4.9	9.8	4.9	9.4	4.7	9.0	4.6	8.3	4.2
	-18.8	-19.0	10.1	4.8	10.2	5.0	9.8	4.8	9.4	4.6	9.0	4.5	8.3	4.1
	-16.7	-17.0	10.8	5.0	10.6	4.9	9.8	4.6	9.4	4.4	9.0	4.3	8.3	3.9
	-13.7	-15.0	11.3	5.0	10.6	4.7	9.8	4.4	9.4	4.2	9.0	4.1	8.3	3.7
	-11.8	-13.0	11.3	4.8	10.6	4.5	9.8	4.2	9.4	4.0	9.0	3.9	8.3	3.6
	-9.8	-11.0	11.3	4.6	10.6	4.3	9.8	4.0	9.4	3.8	9.0	3.7	8.3	3.4
	-9.5	-10.0	11.3	4.5	10.6	4.2	9.8	3.9	9.4	3.7	9.0	3.6	8.3	3.3
	-8.5	-9.1	11.3	4.3	10.6	4.1	9.8	3.8	9.4	3.6	9.0	3.5	8.3	3.2
	-7.0	-7.6	11.3	4.2	10.6	3.9	9.8	3.6	9.4	3.5	9.0	3.4	8.3	3.1
	-5.0	-5.6	11.3	4.0	10.6	3.7	9.8	3.5	9.4	3.3	9.0	3.2	8.3	2.9
	-3.0	-3.7	11.3	3.8	10.6	3.5	9.8	3.3	9.4	3.2	9.0	3.0	8.3	2.8
	0.0	-0.7	11.3	3.5	10.6	3.2	9.8	3.0	9.4	2.9	9.0	2.8	8.3	2.6
	3.0	2.2	11.3	3.2	10.6	3.0	9.8	2.8	9.4	2.7	9.0	2.6	8.3	2.4
	5.0	4.1	11.3	3.0	10.6	2.8	9.8	2.6	9.4	2.5	9.0	2.4	8.3	2.3
	7.0	6.0	11.3	2.9	10.6	2.7	9.8	2.5	9.4	2.4	9.0	2.3	8.3	2.1
9.0	7.9	11.3	2.7	10.6	2.5	9.8	2.4	9.4	2.3	9.0	2.2	8.3	2.0	
11.0	9.8	11.3	2.5	10.6	2.4	9.8	2.2	9.4	2.1	9.0	2.0	8.3	1.9	
13.0	11.8	11.3	2.4	10.6	2.2	9.8	2.1	9.4	2.0	9.0	1.9	8.3	1.8	
15.0	13.7	11.3	2.3	10.6	2.1	9.8	1.9	9.4	1.9	9.0	1.8	8.3	1.7	
60%	-19.8	-20.0	9.7	4.8	9.0	4.5	8.4	4.2	8.1	4.1	7.8	3.9	7.1	3.6
	-18.8	-19.0	9.7	4.7	9.0	4.4	8.4	4.1	8.1	4.0	7.8	3.8	7.1	3.6
	-16.7	-17.0	9.7	4.5	9.0	4.2	8.4	3.9	8.1	3.8	7.8	3.7	7.1	3.4
	-13.7	-15.0	9.7	4.3	9.0	4.0	8.4	3.7	8.1	3.6	7.8	3.5	7.1	3.2
	-11.8	-13.0	9.7	4.1	9.0	3.8	8.4	3.5	8.1	3.4	7.8	3.3	7.1	3.1
	-9.8	-11.0	9.7	3.8	9.0	3.6	8.4	3.4	8.1	3.3	7.8	3.1	7.1	2.9
	-9.5	-10.0	9.7	3.7	9.0	3.5	8.4	3.3	8.1	3.2	7.8	3.1	7.1	2.8
	-8.5	-9.1	9.7	3.7	9.0	3.4	8.4	3.2	8.1	3.1	7.8	3.0	7.1	2.8
	-7.0	-7.6	9.7	3.5	9.0	3.3	8.4	3.1	8.1	3.0	7.8	2.9	7.1	2.7
	-5.0	-5.6	9.7	3.3	9.0	3.1	8.4	2.9	8.1	2.8	7.8	2.7	7.1	2.5
	-3.0	-3.7	9.7	3.2	9.0	3.0	8.4	2.8	8.1	2.7	7.8	2.6	7.1	2.4
	0.0	-0.7	9.7	2.9	9.0	2.7	8.4	2.6	8.1	2.5	7.8	2.4	7.1	2.2
	3.0	2.2	9.7	2.7	9.0	2.5	8.4	2.4	8.1	2.3	7.8	2.2	7.1	2.0
	5.0	4.1	9.7	2.5	9.0	2.4	8.4	2.2	8.1	2.1	7.8	2.1	7.1	1.9
	7.0	6.0	9.7	2.4	9.0	2.3	8.4	2.1	8.1	2.0	7.8	2.0	7.1	1.8
9.0	7.9	9.7	2.3	9.0	2.1	8.4	2.0	8.1	1.9	7.8	1.8	7.1	1.7	
11.0	9.8	9.7	2.1	9.0	2.0	8.4	1.9	8.1	1.8	7.8	1.7	7.1	1.6	
13.0	11.8	9.7	2.0	9.0	1.9	8.4	1.8	8.1	1.7	7.8	1.6	7.1	1.5	
15.0	13.7	9.7	1.9	9.0	1.7	8.4	1.6	8.1	1.6	7.8	1.5	7.1	1.4	
50%	-19.8	-20.0	8.1	4.0	7.5	3.8	7.0	3.5	6.7	3.4	6.5	3.3	5.9	3.1
	-18.8	-19.0	8.1	3.9	7.5	3.7	7.0	3.4	6.7	3.3	6.5	3.2	5.9	3.0
	-16.7	-17.0	8.1	3.7	7.5	3.5	7.0	3.3	6.7	3.2	6.5	3.1	5.9	2.8
	-13.7	-15.0	8.1	3.5	7.5	3.3	7.0	3.1	6.7	3.0	6.5	2.9	5.9	2.7
	-11.8	-13.0	8.1	3.3	7.5	3.1	7.0	3.0	6.7	2.9	6.5	2.8	5.9	2.6
	-9.8	-11.0	8.1	3.2	7.5	3.0	7.0	2.8	6.7	2.7	6.5	2.6	5.9	2.4
	-9.5	-10.0	8.1	3.1	7.5	2.9	7.0	2.7	6.7	2.6	6.5	2.5	5.9	2.4
	-8.5	-9.1	8.1	3.0	7.5	2.8	7.0	2.7	6.7	2.6	6.5	2.5	5.9	2.3
	-7.0	-7.6	8.1	2.9	7.5	2.7	7.0	2.6	6.7	2.5	6.5	2.4	5.9	2.2
	-5.0	-5.6	8.1	2.8	7.5	2.6	7.0	2.4	6.7	2.3	6.5	2.3	5.9	2.1
	-3.0	-3.7	8.1	2.6	7.5	2.5	7.0	2.3	6.7	2.2	6.5	2.1	5.9	2.0
	0.0	-0.7	8.1	2.4	7.5	2.3	7.0	2.1	6.7	2.0	6.5	2.0	5.9	1.8
	3.0	2.2	8.1	2.2	7.5	2.1	7.0	1.9	6.7	1.9	6.5	1.8	5.9	1.7
	5.0	4.1	8.1	2.1	7.5	2.0	7.0	1.8	6.7	1.8	6.5	1.7	5.9	1.6
	7.0	6.0	8.1	2.0	7.5	1.8	7.0	1.7	6.7	1.7	6.5	1.6	5.9	1.5
9.0	7.9	8.1	1.8	7.5	1.7	7.0	1.6	6.7	1.6	6.5	1.5	5.9	1.4	
11.0	9.8	8.1	1.7	7.5	1.7	7.0	1.6	6.7	1.5	6.5	1.5	5.9	1.4	
13.0	11.8	8.1	1.6	7.5	1.6	7.0	1.5	6.7	1.4	6.5	1.4	5.9	1.3	
15.0	13.7	8.1	1.5	7.5	1.4	7.0	1.4	6.7	1.3	6.5	1.3	5.9	1.2	

Abbreviations:

CR: Combination ratio

TC: Total capacity (kW)

PI: Power input (compressor + outdoor fan motor) (kW)

Notes:

Shaded cells indicate rating condition.

Table2-8.9:140 model heating capacity - 220-240V~50Hz

CR	Outdoor air temp.		Indoor air temp. °C DB											
			16.0		18.0		20.0		21.0		22.0		24.0	
	°C DB	°C WB	kW	PI	kW	PI	kW	PI	kW	PI	kW	PI	kW	PI
130%	-19.8	-20.0	10.6	4.6	10.5	4.7	10.4	4.7	10.3	4.8	10.3	4.8	10.3	4.9
	-18.8	-19.0	10.9	4.7	10.8	4.7	10.7	4.8	10.7	4.8	10.6	4.8	10.6	4.9
	-16.7	-17.0	11.6	4.7	11.5	4.8	11.4	4.8	11.4	4.9	11.3	4.9	11.3	5.0
	-13.7	-15.0	12.3	4.8	12.2	4.8	12.1	4.9	12.1	5.0	12.0	5.0	11.9	5.2
	-11.8	-13.0	13.0	4.8	12.9	4.9	12.8	5.0	12.8	5.1	12.7	5.2	12.6	5.3
	-9.8	-11.0	13.7	4.9	13.6	5.0	13.5	5.1	13.5	5.2	13.4	5.3	13.3	5.4
	-9.5	-10.0	14.1	5.0	14.0	5.1	13.9	5.2	13.8	5.3	13.8	5.3	13.7	5.5
	-8.5	-9.1	14.4	5.0	14.3	5.1	14.2	5.3	14.2	5.3	14.1	5.4	14.0	5.5
	-7.0	-7.6	15.0	5.1	14.9	5.2	14.8	5.3	14.7	5.4	14.7	5.5	14.6	5.7
	-5.0	-5.6	15.8	5.2	15.6	5.3	15.5	5.5	15.5	5.6	15.4	5.6	15.3	5.8
	-3.0	-3.7	16.5	5.3	16.4	5.5	16.2	5.6	16.2	5.7	16.1	5.8	16.0	6.0
	0.0	-0.7	17.7	5.5	17.6	5.7	17.4	5.8	17.4	5.9	17.3	6.0	17.2	6.2
	3.0	2.2	18.9	5.7	18.7	5.9	18.6	6.1	18.5	6.2	18.5	6.3	17.6	5.9
	5.0	4.1	19.7	5.9	19.5	6.1	19.4	6.3	19.3	6.4	19.2	6.3	17.6	5.7
	7.0	6.0	20.5	6.0	20.3	6.2	20.1	6.4	20.0	6.3	19.2	6.0	17.6	5.4
9.0	7.9	21.3	6.2	21.1	6.4	20.8	6.3	20.0	6.0	19.2	5.7	17.6	5.1	
11.0	9.8	22.2	6.4	21.7	6.4	20.8	6.0	20.0	5.7	19.2	5.4	17.6	4.9	
13.0	11.8	22.8	6.4	22.4	6.3	20.8	5.7	20.0	5.4	19.2	5.1	17.6	4.6	
15.0	13.7	23.3	6.4	22.4	6.0	20.8	5.4	20.0	5.1	19.2	4.9	17.6	4.3	
120%	-19.8	-20.0	10.5	4.7	10.4	4.7	10.3	4.8	10.3	4.8	10.3	4.8	10.2	4.9
	-18.8	-19.0	10.8	4.7	10.7	4.7	10.6	4.8	10.6	4.8	10.6	4.9	10.5	5.0
	-16.7	-17.0	11.5	4.7	11.4	4.8	11.3	4.9	11.3	4.9	11.3	5.0	11.2	5.1
	-13.7	-15.0	12.2	4.8	12.1	4.9	12.0	5.0	12.0	5.0	11.9	5.1	11.9	5.2
	-11.8	-13.0	12.9	4.9	12.8	5.0	12.7	5.1	12.7	5.2	12.6	5.2	12.6	5.3
	-9.8	-11.0	13.6	5.0	13.5	5.1	13.4	5.2	13.4	5.3	13.3	5.3	13.2	5.5
	-9.5	-10.0	14.0	5.0	13.9	5.1	13.8	5.3	13.7	5.3	13.7	5.4	13.6	5.6
	-8.5	-9.1	14.3	5.1	14.2	5.2	14.1	5.3	14.0	5.4	14.0	5.5	13.9	5.6
	-7.0	-7.6	14.9	5.2	14.7	5.3	14.6	5.4	14.6	5.5	14.5	5.6	14.4	5.7
	-5.0	-5.6	15.6	5.3	15.5	5.4	15.4	5.6	15.3	5.7	15.3	5.7	15.2	5.9
	-3.0	-3.7	16.3	5.4	16.2	5.6	16.1	5.7	16.0	5.8	16.0	5.9	15.9	6.1
	0.0	-0.7	17.5	5.6	17.4	5.8	17.3	6.0	17.2	6.1	17.1	6.2	16.2	5.8
	3.0	2.2	18.7	5.9	18.6	6.0	18.4	6.2	18.5	6.3	17.7	6.0	16.2	5.4
	5.0	4.1	19.5	6.0	19.4	6.2	19.2	6.3	18.5	6.0	17.7	5.7	16.2	5.1
	7.0	6.0	20.3	6.2	20.1	6.4	19.2	6.0	18.5	5.7	17.7	5.4	16.2	4.9
9.0	7.9	21.1	6.4	20.7	6.3	19.2	5.7	18.5	5.4	17.7	5.1	16.2	4.6	
11.0	9.8	21.7	6.4	20.7	5.9	19.2	5.4	18.5	5.1	17.7	4.9	16.2	4.3	
13.0	11.8	22.2	6.2	20.7	5.6	19.2	5.1	18.5	4.8	17.7	4.6	16.2	4.1	
15.0	13.7	22.2	5.9	20.7	5.3	19.2	4.8	18.5	4.6	17.7	4.3	16.2	3.9	
110%	-19.8	-20.0	10.4	4.7	10.3	4.7	10.2	4.8	10.2	4.8	10.2	4.9	10.2	5.0
	-18.8	-19.0	10.7	4.7	10.6	4.8	10.6	4.8	10.5	4.9	10.5	4.9	10.5	5.0
	-16.7	-17.0	11.4	4.8	11.3	4.8	11.2	4.9	11.2	5.0	11.2	5.0	11.1	5.2
	-13.7	-15.0	12.1	4.9	12.0	4.9	11.9	5.0	11.9	5.1	11.8	5.2	11.8	5.3
	-11.8	-13.0	12.8	4.9	12.7	5.0	12.6	5.2	12.5	5.2	12.5	5.3	12.5	5.4
	-9.8	-11.0	13.5	5.0	13.4	5.2	13.3	5.3	13.2	5.4	13.2	5.4	13.1	5.6
	-9.5	-10.0	13.8	5.1	13.7	5.2	13.6	5.4	13.6	5.4	13.6	5.5	13.5	5.7
	-8.5	-9.1	14.2	5.2	14.0	5.3	14.0	5.4	13.9	5.5	13.9	5.6	13.8	5.7
	-7.0	-7.6	14.7	5.3	14.6	5.4	14.5	5.5	14.5	5.6	14.4	5.7	14.3	5.9
	-5.0	-5.6	15.5	5.4	15.3	5.5	15.2	5.7	15.2	5.8	15.1	5.9	14.9	5.8
	-3.0	-3.7	16.2	5.5	16.1	5.7	15.9	5.9	15.9	5.9	15.9	6.0	14.9	5.6
	0.0	-0.7	17.4	5.8	17.2	5.9	17.1	6.1	16.9	6.0	16.2	5.7	14.9	5.2
	3.0	2.2	18.5	6.0	18.4	6.2	17.6	5.9	16.9	5.6	16.2	5.3	14.9	4.8
	5.0	4.1	19.3	6.2	19.0	6.1	17.6	5.6	16.9	5.3	16.2	5.1	14.9	4.6
	7.0	6.0	20.3	6.4	19.0	5.8	17.6	5.3	16.9	5.1	16.2	4.8	14.9	4.3
9.0	7.9	20.3	6.1	19.0	5.6	17.6	5.1	16.9	4.8	16.2	4.6	14.9	4.1	
11.0	9.8	20.3	5.8	19.0	5.3	17.6	4.8	16.9	4.6	16.2	4.3	14.9	3.9	
13.0	11.8	20.3	5.5	19.0	5.0	17.6	4.5	16.9	4.3	16.2	4.1	14.9	3.7	
15.0	13.7	20.3	5.2	19.0	4.7	17.6	4.3	16.9	4.0	16.2	3.8	14.9	3.5	

Abbreviations:

CR: Combination ratio

TC: Total capacity (kW)

PI: Power input (compressor + outdoor fan motor) (kW)

Notes:

Shaded cells indicate rating condition.

Table continued on next page ...

Table2-8.9:140 model heating capacity - 220-240V~50Hz (continued)

CR	Outdoor air temp.		Indoor air temp. °C DB											
			16.0		18.0		20.0		21.0		22.0		24.0	
	°C DB	°C WB	TC	PI	TC	PI	TC	PI	TC	PI	TC	PI	TC	PI
100%	-19.8	-20.0	10.3	4.7	10.2	4.8	10.2	4.8	10.1	4.9	10.1	4.9	10.1	5.1
	-18.8	-19.0	10.6	4.7	10.5	4.8	10.5	4.9	10.5	4.9	10.5	5.0	10.4	5.1
	-16.7	-17.0	11.3	4.8	11.2	4.9	11.1	5.0	11.1	5.1	11.1	5.1	11.1	5.3
	-13.7	-15.0	11.9	4.9	11.9	5.0	11.8	5.1	11.8	5.2	11.8	5.2	11.7	5.4
	-11.8	-13.0	12.6	5.0	12.5	5.1	12.5	5.3	12.4	5.3	12.4	5.4	12.4	5.5
	-9.8	-11.0	13.3	5.1	13.2	5.3	13.2	5.4	13.1	5.5	13.1	5.5	13.1	5.7
	-9.5	-10.0	13.7	5.2	13.6	5.3	13.5	5.5	13.5	5.5	13.5	5.6	13.5	5.8
	-8.5	-9.1	14.0	5.3	13.9	5.4	13.8	5.5	13.8	5.6	13.8	5.7	13.5	5.7
	-7.0	-7.6	14.6	5.4	14.5	5.5	14.4	5.7	14.3	5.7	14.3	5.8	13.5	5.5
	-5.0	-5.6	15.3	5.5	15.2	5.7	15.1	5.8	15.1	5.9	14.8	5.8	13.5	5.2
	-3.0	-3.7	16.0	5.7	15.9	5.8	16.0	6.1	15.4	5.8	14.8	5.5	13.5	5.0
	0.0	-0.7	17.2	5.9	17.2	6.1	16.0	5.6	15.4	5.4	14.8	5.1	13.5	4.6
	3.0	2.2	18.5	6.2	17.2	5.7	16.0	5.2	15.4	5.0	14.8	4.7	13.5	4.3
	5.0	4.1	18.5	5.9	17.2	5.4	16.0	5.0	15.4	4.7	14.8	4.5	13.5	4.1
	7.0	6.0	18.5	5.6	17.2	5.1	16.0	4.7	15.4	4.5	14.8	4.3	13.5	3.9
9.0	7.9	18.5	5.3	17.2	4.9	16.0	4.5	15.4	4.2	14.8	4.0	13.5	3.7	
11.0	9.8	18.5	5.0	17.2	4.6	16.0	4.2	15.4	4.0	14.8	3.8	13.5	3.5	
13.0	11.8	18.5	4.8	17.2	4.3	16.0	4.0	15.4	3.8	14.8	3.6	13.5	3.3	
15.0	13.7	18.5	4.5	17.2	4.1	16.0	3.7	15.4	3.6	14.8	3.4	13.5	3.1	
90%	-19.8	-20.0	10.2	4.7	10.1	4.8	10.1	4.9	10.1	5.0	10.1	5.0	10.1	5.1
	-18.8	-19.0	10.5	4.8	10.4	4.9	10.4	5.0	10.4	5.0	10.4	5.1	10.4	5.2
	-16.7	-17.0	11.2	4.9	11.1	5.0	11.1	5.1	11.0	5.2	11.0	5.2	11.0	5.4
	-13.7	-15.0	11.8	5.0	11.8	5.1	11.7	5.2	11.7	5.3	11.7	5.4	11.7	5.5
	-11.8	-13.0	12.5	5.1	12.4	5.2	12.4	5.4	12.4	5.4	12.3	5.5	12.2	5.5
	-9.8	-11.0	13.2	5.2	13.1	5.4	13.1	5.5	13.0	5.6	13.0	5.7	12.2	5.3
	-9.5	-10.0	13.6	5.3	13.5	5.5	13.4	5.6	13.4	5.7	13.3	5.7	12.2	5.2
	-8.5	-9.1	13.9	5.4	13.8	5.5	13.7	5.7	13.8	5.8	13.3	5.5	12.2	5.1
	-7.0	-7.6	14.4	5.5	14.3	5.7	14.4	5.9	13.8	5.6	13.3	5.4	12.2	4.9
	-5.0	-5.6	15.1	5.7	15.0	5.8	14.4	5.6	13.8	5.3	13.3	5.1	12.2	4.7
	-3.0	-3.7	15.8	5.9	15.5	5.8	14.4	5.3	13.8	5.1	13.3	4.9	12.2	4.4
	0.0	-0.7	16.6	5.8	15.5	5.4	14.4	4.9	13.8	4.7	13.3	4.5	12.2	4.1
	3.0	2.2	16.6	5.4	15.5	5.0	14.4	4.6	13.8	4.4	13.3	4.2	12.2	3.8
	5.0	4.1	16.6	5.1	15.5	4.7	14.4	4.3	13.8	4.1	13.3	4.0	12.2	3.6
	7.0	6.0	16.6	4.9	15.5	4.5	14.4	4.1	13.8	3.9	13.3	3.7	12.2	3.4
9.0	7.9	16.6	4.6	15.5	4.2	14.4	3.9	13.8	3.7	13.3	3.6	12.2	3.2	
11.0	9.8	16.6	4.4	15.5	4.0	14.4	3.7	13.8	3.5	13.3	3.4	12.2	3.1	
13.0	11.8	16.6	4.1	15.5	3.8	14.4	3.5	13.8	3.3	13.3	3.2	12.2	2.9	
15.0	13.7	16.6	3.9	15.5	3.6	14.4	3.3	13.8	3.1	13.3	3.0	12.2	2.7	
80%	-19.8	-20.0	10.1	4.8	10.1	4.9	10.0	5.0	10.0	5.1	10.0	5.1	10.1	5.3
	-18.8	-19.0	10.4	4.9	10.4	5.0	10.4	5.1	10.4	5.1	10.4	5.2	10.4	5.4
	-16.7	-17.0	11.1	5.0	11.0	5.1	11.0	5.2	11.0	5.3	11.0	5.4	10.8	5.3
	-13.7	-15.0	11.7	5.1	11.7	5.2	11.6	5.4	11.6	5.4	11.8	5.6	10.8	5.1
	-11.8	-13.0	12.4	5.2	12.3	5.4	12.3	5.5	12.3	5.6	11.8	5.3	10.8	4.9
	-9.8	-11.0	13.1	5.4	13.0	5.6	12.8	5.5	12.3	5.3	11.8	5.1	10.8	4.7
	-9.5	-10.0	13.4	5.5	13.3	5.6	12.8	5.4	12.3	5.2	11.8	5.0	10.8	4.6
	-8.5	-9.1	13.7	5.6	13.8	5.7	12.8	5.3	12.3	5.1	11.8	4.9	10.8	4.5
	-7.0	-7.6	14.3	5.7	13.8	5.5	12.8	5.1	12.3	4.9	11.8	4.7	10.8	4.3
	-5.0	-5.6	14.8	5.7	13.8	5.3	12.8	4.9	12.3	4.7	11.8	4.5	10.8	4.1
	-3.0	-3.7	14.8	5.4	13.8	5.0	12.8	4.6	12.3	4.4	11.8	4.3	10.8	3.9
	0.0	-0.7	14.8	5.0	13.8	4.6	12.8	4.3	12.3	4.1	11.8	3.9	10.8	3.6
	3.0	2.2	14.8	4.6	13.8	4.3	12.8	4.0	12.3	3.8	11.8	3.6	10.8	3.3
	5.0	4.1	14.8	4.4	13.8	4.1	12.8	3.8	12.3	3.6	11.8	3.5	10.8	3.2
	7.0	6.0	14.8	4.2	13.8	3.9	12.8	3.6	12.3	3.4	11.8	3.3	10.8	3.0
9.0	7.9	14.8	3.9	13.8	3.7	12.8	3.4	12.3	3.2	11.8	3.1	10.8	2.8	
11.0	9.8	14.8	3.7	13.8	3.5	12.8	3.2	12.3	3.1	11.8	2.9	10.8	2.7	
13.0	11.8	14.8	3.5	13.8	3.2	12.8	3.0	12.3	2.9	11.8	2.7	10.8	2.5	
15.0	13.7	14.8	3.3	13.8	3.1	12.8	2.8	12.3	2.7	11.8	2.6	10.8	2.4	

Abbreviations:

CR: Combination ratio

TC: Total capacity (kW)

PI: Power input (compressor + outdoor fan motor) (kW)

Notes:

Shaded cells indicate rating condition.

Table continued on next page ...

Table2-8.9:140 model heating capacity - 220-240V~50Hz (continued)

CR	Outdoor air temp.		Indoor air temp. °C DB											
			16.0		18.0		20.0		21.0		22.0		24.0	
	°C DB	°C WB	TC	PI	TC	PI	TC	PI	TC	PI	TC	PI	TC	PI
70%	-19.8	-20.0	10.0	4.9	10.0	5.0	10.0	5.1	10.0	5.2	10.1	5.3	9.5	5.0
	-18.8	-19.0	10.3	5.0	10.3	5.1	10.3	5.2	10.3	5.3	10.3	5.3	9.5	4.9
	-16.7	-17.0	11.0	5.1	10.9	5.2	10.9	5.4	10.8	5.3	10.3	5.1	9.5	4.7
	-13.7	-15.0	11.6	5.3	11.6	5.4	11.2	5.2	10.8	5.0	10.3	4.8	9.5	4.5
	-11.8	-13.0	12.3	5.4	12.1	5.4	11.2	5.0	10.8	4.8	10.3	4.6	9.5	4.3
	-9.8	-11.0	12.9	5.5	12.1	5.1	11.2	4.8	10.8	4.6	10.3	4.4	9.5	4.1
	-9.5	-10.0	12.9	5.4	12.1	5.0	11.2	4.7	10.8	4.5	10.3	4.3	9.5	4.0
	-8.5	-9.1	12.9	5.3	12.1	4.9	11.2	4.6	10.8	4.4	10.3	4.2	9.5	3.9
	-7.0	-7.6	12.9	5.1	12.1	4.7	11.2	4.4	10.8	4.2	10.3	4.1	9.5	3.7
	-5.0	-5.6	12.9	4.8	12.1	4.5	11.2	4.2	10.8	4.0	10.3	3.9	9.5	3.5
	-3.0	-3.7	12.9	4.6	12.1	4.3	11.2	4.0	10.8	3.8	10.3	3.7	9.5	3.4
	0.0	-0.7	12.9	4.3	12.1	4.0	11.2	3.7	10.8	3.5	10.3	3.4	9.5	3.1
	3.0	2.2	12.9	3.9	12.1	3.7	11.2	3.4	10.8	3.3	10.3	3.1	9.5	2.9
	5.0	4.1	12.9	3.7	12.1	3.5	11.2	3.2	10.8	3.1	10.3	3.0	9.5	2.7
	7.0	6.0	12.9	3.5	12.1	3.3	11.2	3.0	10.8	2.9	10.3	2.8	9.5	2.6
9.0	7.9	12.9	3.3	12.1	3.1	11.2	2.9	10.8	2.8	10.3	2.7	9.5	2.4	
11.0	9.8	12.9	3.2	12.1	2.9	11.2	2.7	10.8	2.6	10.3	2.5	9.5	2.3	
13.0	11.8	12.9	3.0	12.1	2.8	11.2	2.6	10.8	2.5	10.3	2.3	9.5	2.1	
15.0	13.7	12.9	2.8	12.1	2.6	11.2	2.4	10.8	2.3	10.3	2.2	9.5	2.0	
60%	-19.8	-20.0	10.0	5.1	10.0	5.2	9.6	5.0	9.2	4.8	8.9	4.6	8.1	4.3
	-18.8	-19.0	10.3	5.2	10.3	5.3	9.6	4.9	9.2	4.7	8.9	4.5	8.1	4.2
	-16.7	-17.0	11.1	5.4	10.3	5.0	9.6	4.7	9.2	4.5	8.9	4.3	8.1	4.0
	-13.7	-15.0	11.1	5.1	10.3	4.8	9.6	4.5	9.2	4.3	8.9	4.1	8.1	3.8
	-11.8	-13.0	11.1	4.9	10.3	4.6	9.6	4.3	9.2	4.1	8.9	3.9	8.1	3.6
	-9.8	-11.0	11.1	4.7	10.3	4.4	9.6	4.0	9.2	3.9	8.9	3.8	8.1	3.5
	-9.5	-10.0	11.1	4.5	10.3	4.2	9.6	4.0	9.2	3.8	8.9	3.7	8.1	3.4
	-8.5	-9.1	11.1	4.4	10.3	4.2	9.6	3.9	9.2	3.7	8.9	3.6	8.1	3.3
	-7.0	-7.6	11.1	4.3	10.3	4.0	9.6	3.7	9.2	3.6	8.9	3.4	8.1	3.2
	-5.0	-5.6	11.1	4.1	10.3	3.8	9.6	3.5	9.2	3.4	8.9	3.3	8.1	3.0
	-3.0	-3.7	11.1	3.9	10.3	3.6	9.6	3.4	9.2	3.2	8.9	3.1	8.1	2.9
	0.0	-0.7	11.1	3.6	10.3	3.3	9.6	3.1	9.2	3.0	8.9	2.9	8.1	2.6
	3.0	2.2	11.1	3.3	10.3	3.1	9.6	2.9	9.2	2.8	8.9	2.6	8.1	2.4
	5.0	4.1	11.1	3.1	10.3	2.9	9.6	2.7	9.2	2.6	8.9	2.5	8.1	2.3
	7.0	6.0	11.1	2.9	10.3	2.8	9.6	2.6	9.2	2.5	8.9	2.4	8.1	2.2
9.0	7.9	11.1	2.8	10.3	2.6	9.6	2.4	9.2	2.3	8.9	2.2	8.1	2.0	
11.0	9.8	11.1	2.6	10.3	2.4	9.6	2.3	9.2	2.2	8.9	2.1	8.1	1.9	
13.0	11.8	11.1	2.5	10.3	2.3	9.6	2.1	9.2	2.1	8.9	2.0	8.1	1.8	
15.0	13.7	11.1	2.3	10.3	2.2	9.6	2.0	9.2	1.9	8.9	1.8	8.1	1.7	
50%	-19.8	-20.0	9.2	4.8	8.6	4.5	8.0	4.2	7.7	4.0	7.4	3.9	6.8	3.6
	-18.8	-19.0	9.2	4.7	8.6	4.4	8.0	4.1	7.7	3.9	7.4	3.8	6.8	3.5
	-16.7	-17.0	9.2	4.4	8.6	4.2	8.0	3.9	7.7	3.8	7.4	3.6	6.8	3.4
	-13.7	-15.0	9.2	4.2	8.6	4.0	8.0	3.7	7.7	3.6	7.4	3.4	6.8	3.2
	-11.8	-13.0	9.2	4.0	8.6	3.8	8.0	3.5	7.7	3.4	7.4	3.3	6.8	3.0
	-9.8	-11.0	9.2	3.8	8.6	3.6	8.0	3.3	7.7	3.2	7.4	3.1	6.8	2.9
	-9.5	-10.0	9.2	3.7	8.6	3.5	8.0	3.3	7.7	3.2	7.4	3.0	6.8	2.8
	-8.5	-9.1	9.2	3.6	8.6	3.4	8.0	3.2	7.7	3.1	7.4	3.0	6.8	2.7
	-7.0	-7.6	9.2	3.5	8.6	3.3	8.0	3.1	7.7	3.0	7.4	2.9	6.8	2.6
	-5.0	-5.6	9.2	3.3	8.6	3.1	8.0	2.9	7.7	2.8	7.4	2.7	6.8	2.5
	-3.0	-3.7	9.2	3.2	8.6	3.0	8.0	2.8	7.7	2.7	7.4	2.6	6.8	2.4
	0.0	-0.7	9.2	2.9	8.6	2.7	8.0	2.6	7.7	2.5	7.4	2.4	6.8	2.2
	3.0	2.2	9.2	2.7	8.6	2.5	8.0	2.4	7.7	2.3	7.4	2.2	6.8	2.0
	5.0	4.1	9.2	2.5	8.6	2.4	8.0	2.2	7.7	2.1	7.4	2.1	6.8	1.9
	7.0	6.0	9.2	2.4	8.6	2.2	8.0	2.1	7.7	2.0	7.4	1.9	6.8	1.8
9.0	7.9	9.2	2.3	8.6	2.1	8.0	2.0	7.7	1.9	7.4	1.8	6.8	1.7	
11.0	9.8	9.2	2.1	8.6	2.0	8.0	1.9	7.7	1.8	7.4	1.7	6.8	1.6	
13.0	11.8	9.2	2.0	8.6	1.9	8.0	1.8	7.7	1.7	7.4	1.7	6.8	1.5	
15.0	13.7	9.2	1.9	8.6	1.7	8.0	1.6	7.7	1.6	7.4	1.5	6.8	1.4	

Abbreviations:

CR: Combination ratio

TC: Total capacity (kW)

PI: Power input (compressor + outdoor fan motor) (kW)

Notes:

Shaded cells indicate rating condition.

Table2-8.10:160 model heating capacity - 220-240V~50Hz

CR	Outdoor air temp.		Indoor air temp. °C DB											
			16.0		18.0		20.0		21.0		22.0		24.0	
	°C DB	°C WB	TC	PI	TC	PI	TC	PI	TC	PI	TC	PI	TC	PI
130%	-19.8	-20.0	11.2	4.7	11.1	4.8	11.0	4.9	10.9	5.0	10.8	5.0	10.8	5.1
	-18.8	-19.0	11.6	4.8	11.4	4.9	11.3	5.0	11.3	5.0	11.2	5.1	11.1	5.2
	-16.7	-17.0	12.3	4.9	12.2	5.0	12.0	5.1	12.0	5.1	11.9	5.2	11.8	5.3
	-13.7	-15.0	13.0	5.0	12.9	5.1	12.8	5.2	12.7	5.3	12.7	5.3	12.6	5.5
	-11.8	-13.0	13.8	5.1	13.7	5.2	13.5	5.3	13.5	5.4	13.4	5.5	13.3	5.6
	-9.8	-11.0	14.5	5.2	14.4	5.3	14.3	5.5	14.2	5.5	14.2	5.6	14.0	5.7
	-9.5	-10.0	14.9	5.3	14.8	5.4	14.7	5.5	14.6	5.6	14.5	5.7	14.4	5.8
	-8.5	-9.1	15.3	5.3	15.1	5.4	15.0	5.6	14.9	5.7	14.9	5.7	14.8	5.9
	-7.0	-7.6	15.8	5.4	15.7	5.5	15.6	5.7	15.5	5.8	15.4	5.8	15.3	6.0
	-5.0	-5.6	16.6	5.5	16.5	5.7	16.4	5.8	16.3	5.9	16.2	6.0	16.1	6.2
	-3.0	-3.7	17.4	5.6	17.3	5.8	17.1	6.0	17.0	6.1	17.0	6.1	16.8	6.3
	0.0	-0.7	18.6	5.9	18.5	6.0	18.3	6.2	18.3	6.3	18.2	6.4	18.1	6.6
	3.0	2.2	19.9	6.1	19.7	6.3	19.5	6.4	19.5	6.5	19.4	6.6	19.3	6.7
	5.0	4.1	20.7	6.2	20.5	6.4	20.4	6.6	20.3	6.7	20.2	6.8	19.3	6.3
	7.0	6.0	21.5	6.4	21.4	6.6	21.2	6.8	21.1	6.9	21.0	6.8	19.3	6.1
9.0	7.9	22.4	6.5	22.2	6.7	22.0	6.9	21.9	6.9	21.0	6.4	19.3	5.8	
11.0	9.8	23.2	6.7	23.1	6.9	22.8	6.9	21.9	6.5	21.0	6.1	19.3	5.5	
13.0	11.8	24.2	6.9	24.0	7.1	22.8	6.5	21.9	6.1	21.0	5.8	19.3	5.2	
15.0	13.7	25.1	7.0	24.5	6.8	22.8	6.1	21.9	5.8	21.0	5.5	19.3	4.9	
120%	-19.8	-20.0	11.1	4.8	11.0	4.9	10.8	4.9	10.8	5.0	10.7	5.1	10.7	5.2
	-18.8	-19.0	11.4	4.8	11.3	4.9	11.2	5.0	11.1	5.1	11.1	5.1	11.0	5.2
	-16.7	-17.0	12.2	4.9	12.0	5.0	11.9	5.1	11.9	5.2	11.8	5.2	11.7	5.4
	-13.7	-15.0	12.9	5.0	12.8	5.1	12.7	5.3	12.6	5.3	12.6	5.4	12.5	5.5
	-11.8	-13.0	13.6	5.1	13.5	5.3	13.4	5.4	13.3	5.5	13.3	5.5	13.2	5.7
	-9.8	-11.0	14.4	5.3	14.3	5.4	14.1	5.5	14.1	5.6	14.0	5.7	13.9	5.8
	-9.5	-10.0	14.8	5.3	14.6	5.5	14.5	5.6	14.4	5.7	14.4	5.7	14.3	5.9
	-8.5	-9.1	15.1	5.4	15.0	5.5	14.8	5.7	14.8	5.7	14.7	5.8	14.6	6.0
	-7.0	-7.6	15.7	5.5	15.5	5.6	15.4	5.8	15.4	5.9	15.3	5.9	15.2	6.1
	-5.0	-5.6	16.5	5.6	16.3	5.8	16.2	5.9	16.1	6.0	16.1	6.1	16.0	6.3
	-3.0	-3.7	17.2	5.7	17.1	5.9	16.9	6.1	16.9	6.2	16.8	6.3	16.7	6.4
	0.0	-0.7	18.4	6.0	18.3	6.1	18.2	6.3	18.1	6.4	18.0	6.5	17.8	6.5
	3.0	2.2	19.7	6.2	19.5	6.4	19.4	6.6	19.3	6.7	19.4	6.8	17.8	6.0
	5.0	4.1	20.5	6.4	20.3	6.6	20.2	6.8	20.2	6.8	19.4	6.4	17.8	5.7
	7.0	6.0	21.3	6.5	21.1	6.7	21.0	6.8	20.2	6.4	19.4	6.1	17.8	5.5
9.0	7.9	22.1	6.7	22.0	6.9	21.0	6.4	20.2	6.1	19.4	5.8	17.8	5.2	
11.0	9.8	23.0	6.9	22.6	6.8	21.0	6.1	20.2	5.8	19.4	5.5	17.8	4.9	
13.0	11.8	24.2	7.1	22.6	6.4	21.0	5.8	20.2	5.5	19.4	5.2	17.8	4.6	
15.0	13.7	24.2	6.7	22.6	6.1	21.0	5.5	20.2	5.2	19.4	4.9	17.8	4.4	
110%	-19.8	-20.0	11.0	4.8	10.8	4.9	10.7	5.0	10.7	5.0	10.7	5.1	10.6	5.2
	-18.8	-19.0	11.3	4.9	11.2	5.0	11.1	5.1	11.1	5.1	11.0	5.2	10.9	5.3
	-16.7	-17.0	12.0	5.0	11.9	5.1	11.8	5.2	11.8	5.2	11.7	5.3	11.6	5.4
	-13.7	-15.0	12.8	5.1	12.6	5.2	12.5	5.3	12.5	5.4	12.4	5.5	12.3	5.6
	-11.8	-13.0	13.5	5.2	13.4	5.3	13.2	5.5	13.2	5.5	13.1	5.6	13.1	5.8
	-9.8	-11.0	14.2	5.3	14.1	5.5	14.0	5.6	13.9	5.7	13.9	5.8	13.8	5.9
	-9.5	-10.0	14.6	5.4	14.5	5.5	14.4	5.7	14.3	5.8	14.2	5.8	14.1	6.0
	-8.5	-9.1	14.9	5.5	14.8	5.6	14.7	5.8	14.6	5.8	14.6	5.9	14.5	6.1
	-7.0	-7.6	15.5	5.6	15.4	5.7	15.3	5.9	15.2	6.0	15.1	6.0	15.0	6.2
	-5.0	-5.6	16.3	5.7	16.2	5.9	16.0	6.0	16.0	6.1	15.9	6.2	15.8	6.4
	-3.0	-3.7	17.0	5.9	16.9	6.0	16.8	6.2	16.7	6.3	16.6	6.4	16.3	6.3
	0.0	-0.7	18.3	6.1	18.1	6.3	18.0	6.5	17.9	6.6	17.8	6.5	16.3	5.8
	3.0	2.2	19.5	6.4	19.3	6.6	19.3	6.7	18.5	6.3	17.8	6.0	16.3	5.4
	5.0	4.1	20.3	6.5	20.1	6.7	19.3	6.3	18.5	6.0	17.8	5.7	16.3	5.2
	7.0	6.0	21.1	6.7	20.7	6.6	19.3	6.0	18.5	5.7	17.8	5.4	16.3	4.9
9.0	7.9	22.2	6.9	20.7	6.3	19.3	5.7	18.5	5.4	17.8	5.2	16.3	4.6	
11.0	9.8	22.2	6.5	20.7	6.0	19.3	5.4	18.5	5.2	17.8	4.9	16.3	4.4	
13.0	11.8	22.2	6.2	20.7	5.6	19.3	5.1	18.5	4.9	17.8	4.6	16.3	4.1	
15.0	13.7	22.2	5.9	20.7	5.3	19.3	4.8	18.5	4.6	17.8	4.3	16.3	3.9	

Abbreviations:

CR: Combination ratio

TC: Total capacity (kW)

PI: Power input (compressor + outdoor fan motor) (kW)

Notes:

Shaded cells indicate rating condition.

Table continued on next page ...

Table2-8.10:160 model heating capacity - 220-240V~50Hz (continued)

CR	Outdoor air temp.		Indoor air temp. °C DB											
			16.0		18.0		20.0		21.0		22.0		24.0	
	°C DB	°C WB	TC	PI	TC	PI	TC	PI	TC	PI	TC	PI	TC	PI
100%	-19.8	-20.0	10.8	4.9	10.7	5.0	10.6	5.1	10.6	5.1	10.6	5.2	10.5	5.3
	-18.8	-19.0	11.2	4.9	11.1	5.0	11.0	5.1	10.9	5.2	10.9	5.2	10.8	5.4
	-16.7	-17.0	11.9	5.0	11.8	5.1	11.7	5.3	11.6	5.3	11.6	5.4	11.5	5.5
	-13.7	-15.0	12.6	5.2	12.5	5.3	12.4	5.4	12.3	5.5	12.3	5.5	12.2	5.7
	-11.8	-13.0	13.3	5.3	13.2	5.4	13.1	5.6	13.1	5.6	13.0	5.7	12.9	5.9
	-9.8	-11.0	14.1	5.4	13.9	5.6	13.8	5.7	13.8	5.8	13.7	5.9	13.7	6.0
	-9.5	-10.0	14.4	5.5	14.3	5.7	14.2	5.8	14.2	5.9	14.1	6.0	14.0	6.1
	-8.5	-9.1	14.8	5.6	14.6	5.7	14.5	5.9	14.5	6.0	14.4	6.0	14.3	6.2
	-7.0	-7.6	15.3	5.7	15.2	5.8	15.1	6.0	15.0	6.1	15.0	6.2	14.8	6.2
	-5.0	-5.6	16.1	5.9	16.0	6.0	15.9	6.2	15.8	6.3	15.7	6.4	14.8	5.9
	-3.0	-3.7	16.8	6.0	16.7	6.2	16.6	6.4	16.8	6.6	16.2	6.2	14.8	5.6
	0.0	-0.7	18.0	6.3	17.9	6.5	17.5	6.3	16.8	6.0	16.2	5.7	14.8	5.2
	3.0	2.2	19.2	6.6	18.8	6.4	17.5	5.9	16.8	5.6	16.2	5.3	14.8	4.8
	5.0	4.1	20.2	6.7	18.8	6.1	17.5	5.6	16.8	5.3	16.2	5.1	14.8	4.6
	7.0	6.0	20.2	6.3	18.8	5.8	17.5	5.3	16.8	5.1	16.2	4.8	14.8	4.3
9.0	7.9	20.2	6.0	18.8	5.5	17.5	5.0	16.8	4.8	16.2	4.6	14.8	4.1	
11.0	9.8	20.2	5.7	18.8	5.2	17.5	4.8	16.8	4.5	16.2	4.3	14.8	3.9	
13.0	11.8	20.2	5.4	18.8	4.9	17.5	4.5	16.8	4.3	16.2	4.0	14.8	3.7	
15.0	13.7	20.2	5.1	18.8	4.7	17.5	4.2	16.8	4.0	16.2	3.8	14.8	3.4	
90%	-19.8	-20.0	10.7	4.9	10.6	5.0	10.5	5.1	10.5	5.2	10.5	5.2	10.4	5.4
	-18.8	-19.0	11.1	5.0	11.0	5.1	10.9	5.2	10.8	5.3	10.8	5.3	10.7	5.5
	-16.7	-17.0	11.7	5.1	11.6	5.2	11.6	5.4	11.5	5.4	11.5	5.5	11.4	5.6
	-13.7	-15.0	12.5	5.3	12.4	5.4	12.3	5.5	12.2	5.6	12.2	5.7	12.1	5.8
	-11.8	-13.0	13.2	5.4	13.1	5.5	13.0	5.7	12.9	5.8	12.9	5.8	12.8	6.0
	-9.8	-11.0	13.9	5.6	13.8	5.7	13.7	5.9	13.6	5.9	13.6	6.0	13.3	5.9
	-9.5	-10.0	14.3	5.6	14.2	5.8	14.0	5.9	14.0	6.0	14.0	6.1	13.3	5.8
	-8.5	-9.1	14.6	5.7	14.5	5.9	14.4	6.0	14.3	6.1	14.5	6.3	13.3	5.6
	-7.0	-7.6	15.2	5.8	15.0	6.0	14.9	6.2	15.1	6.4	14.5	6.0	13.3	5.5
	-5.0	-5.6	15.9	6.0	15.8	6.2	15.8	6.3	15.1	6.0	14.5	5.7	13.3	5.2
	-3.0	-3.7	16.6	6.2	16.5	6.4	15.8	6.0	15.1	5.7	14.5	5.5	13.3	5.0
	0.0	-0.7	18.2	6.6	17.0	6.0	15.8	5.5	15.1	5.3	14.5	5.1	13.3	4.6
	3.0	2.2	18.2	6.1	17.0	5.6	15.8	5.1	15.1	4.9	14.5	4.7	13.3	4.3
	5.0	4.1	18.2	5.8	17.0	5.3	15.8	4.9	15.1	4.7	14.5	4.4	13.3	4.0
	7.0	6.0	18.2	5.5	17.0	5.1	15.8	4.6	15.1	4.4	14.5	4.2	13.3	3.8
9.0	7.9	18.2	5.2	17.0	4.8	15.8	4.4	15.1	4.2	14.5	4.0	13.3	3.6	
11.0	9.8	18.2	4.9	17.0	4.5	15.8	4.1	15.1	4.0	14.5	3.8	13.3	3.4	
13.0	11.8	18.2	4.7	17.0	4.3	15.8	3.9	15.1	3.7	14.5	3.6	13.3	3.2	
15.0	13.7	18.2	4.4	17.0	4.0	15.8	3.7	15.1	3.5	14.5	3.3	13.3	3.0	
80%	-19.8	-20.0	10.6	5.0	10.5	5.1	10.4	5.2	10.4	5.3	10.4	5.4	10.3	5.5
	-18.8	-19.0	10.9	5.1	10.8	5.2	10.8	5.3	10.7	5.4	10.7	5.4	10.7	5.6
	-16.7	-17.0	11.6	5.2	11.5	5.3	11.4	5.5	11.4	5.5	11.4	5.6	11.3	5.8
	-13.7	-15.0	12.3	5.4	12.2	5.5	12.1	5.7	12.1	5.7	12.1	5.8	11.8	5.7
	-11.8	-13.0	13.0	5.5	12.9	5.7	12.8	5.8	12.8	5.9	12.9	6.0	11.8	5.4
	-9.8	-11.0	13.7	5.7	13.6	5.9	13.5	6.0	13.5	6.0	12.9	5.7	11.8	5.2
	-9.5	-10.0	14.1	5.8	14.0	6.0	14.0	6.1	13.5	5.8	12.9	5.5	11.8	5.1
	-8.5	-9.1	14.4	5.9	14.3	6.1	14.0	6.0	13.5	5.7	12.9	5.4	11.8	5.0
	-7.0	-7.6	15.0	6.0	15.1	6.3	14.0	5.7	13.5	5.5	12.9	5.2	11.8	4.8
	-5.0	-5.6	15.7	6.2	15.1	5.9	14.0	5.4	13.5	5.2	12.9	5.0	11.8	4.6
	-3.0	-3.7	16.2	6.1	15.1	5.6	14.0	5.2	13.5	5.0	12.9	4.8	11.8	4.3
	0.0	-0.7	16.2	5.6	15.1	5.2	14.0	4.8	13.5	4.6	12.9	4.4	11.8	4.0
	3.0	2.2	16.2	5.2	15.1	4.8	14.0	4.5	13.5	4.3	12.9	4.1	11.8	3.7
	5.0	4.1	16.2	5.0	15.1	4.6	14.0	4.2	13.5	4.0	12.9	3.9	11.8	3.5
	7.0	6.0	16.2	4.7	15.1	4.3	14.0	4.0	13.5	3.8	12.9	3.7	11.8	3.3
9.0	7.9	16.2	4.5	15.1	4.1	14.0	3.8	13.5	3.6	12.9	3.5	11.8	3.2	
11.0	9.8	16.2	4.2	15.1	3.9	14.0	3.6	13.5	3.4	12.9	3.3	11.8	3.0	
13.0	11.8	16.2	3.9	15.1	3.7	14.0	3.4	13.5	3.2	12.9	3.1	11.8	2.8	
15.0	13.7	16.2	3.7	15.1	3.4	14.0	3.2	13.5	3.0	12.9	2.9	11.8	2.6	

Abbreviations:

CR: Combination ratio

TC: Total capacity (kW)

PI: Power input (compressor + outdoor fan motor) (kW)

Notes:

Shaded cells indicate rating condition.

Table continued on next page ...

Table2-8.10:160 model heating capacity - 220-240V~50Hz (continued)

CR	Outdoor air temp.		Indoor air temp. °C DB											
			16.0		18.0		20.0		21.0		22.0		24.0	
	°C DB	°C WB	TC	PI	TC	PI	TC	PI	TC	PI	TC	PI	TC	PI
70%	-19.8	-20.0	10.4	5.1	10.4	5.2	10.3	5.4	10.3	5.4	10.3	5.5	10.4	5.6
	-18.8	-19.0	10.8	5.2	10.7	5.3	10.6	5.5	10.6	5.5	10.6	5.6	10.4	5.4
	-16.7	-17.0	11.4	5.4	11.4	5.5	11.3	5.6	11.3	5.7	11.3	5.7	10.4	5.2
	-13.7	-15.0	12.1	5.5	12.1	5.7	12.3	6.0	11.8	5.6	11.3	5.4	10.4	4.9
	-11.8	-13.0	12.8	5.7	12.8	5.9	12.3	5.6	11.8	5.4	11.3	5.1	10.4	4.7
	-9.8	-11.0	13.5	5.9	13.2	5.8	12.3	5.3	11.8	5.1	11.3	4.9	10.4	4.5
	-9.5	-10.0	14.1	6.1	13.2	5.6	12.3	5.2	11.8	5.0	11.3	4.8	10.4	4.4
	-8.5	-9.1	14.1	6.0	13.2	5.5	12.3	5.1	11.8	4.9	11.3	4.7	10.4	4.3
	-7.0	-7.6	14.1	5.7	13.2	5.3	12.3	4.9	11.8	4.7	11.3	4.5	10.4	4.1
	-5.0	-5.6	14.1	5.4	13.2	5.1	12.3	4.7	11.8	4.5	11.3	4.3	10.4	3.9
	-3.0	-3.7	14.1	5.2	13.2	4.8	12.3	4.5	11.8	4.3	11.3	4.1	10.4	3.7
	0.0	-0.7	14.1	4.8	13.2	4.4	12.3	4.1	11.8	3.9	11.3	3.8	10.4	3.5
	3.0	2.2	14.1	4.4	13.2	4.1	12.3	3.8	11.8	3.6	11.3	3.5	10.4	3.2
	5.0	4.1	14.1	4.2	13.2	3.9	12.3	3.6	11.8	3.5	11.3	3.3	10.4	3.0
	7.0	6.0	14.1	4.0	13.2	3.7	12.3	3.4	11.8	3.3	11.3	3.1	10.4	2.9
9.0	7.9	14.1	3.8	13.2	3.5	12.3	3.2	11.8	3.1	11.3	3.0	10.4	2.7	
11.0	9.8	14.1	3.6	13.2	3.3	12.3	3.0	11.8	2.9	11.3	2.8	10.4	2.6	
13.0	11.8	14.1	3.3	13.2	3.1	12.3	2.9	11.8	2.7	11.3	2.6	10.4	2.4	
15.0	13.7	14.1	3.1	13.2	2.9	12.3	2.7	11.8	2.6	11.3	2.5	10.4	2.3	
60%	-19.8	-20.0	10.3	5.3	10.3	5.4	10.2	5.6	10.1	5.3	9.7	5.1	8.9	4.7
	-18.8	-19.0	10.6	5.4	10.6	5.5	10.5	5.5	10.1	5.2	9.7	5.0	8.9	4.6
	-16.7	-17.0	11.3	5.6	11.3	5.7	10.5	5.2	10.1	5.0	9.7	4.8	8.9	4.4
	-13.7	-15.0	12.1	5.8	11.3	5.3	10.5	5.0	10.1	4.8	9.7	4.6	8.9	4.2
	-11.8	-13.0	12.1	5.5	11.3	5.1	10.5	4.7	10.1	4.6	9.7	4.4	8.9	4.0
	-9.8	-11.0	12.1	5.2	11.3	4.9	10.5	4.5	10.1	4.3	9.7	4.2	8.9	3.8
	-9.5	-10.0	12.1	5.1	11.3	4.7	10.5	4.4	10.1	4.2	9.7	4.1	8.9	3.7
	-8.5	-9.1	12.1	5.0	11.3	4.6	10.5	4.3	10.1	4.1	9.7	4.0	8.9	3.7
	-7.0	-7.6	12.1	4.8	11.3	4.5	10.5	4.1	10.1	4.0	9.7	3.8	8.9	3.5
	-5.0	-5.6	12.1	4.6	11.3	4.2	10.5	3.9	10.1	3.8	9.7	3.6	8.9	3.3
	-3.0	-3.7	12.1	4.3	11.3	4.0	10.5	3.7	10.1	3.6	9.7	3.5	8.9	3.2
	0.0	-0.7	12.1	4.0	11.3	3.7	10.5	3.5	10.1	3.3	9.7	3.2	8.9	2.9
	3.0	2.2	12.1	3.7	11.3	3.4	10.5	3.2	10.1	3.1	9.7	3.0	8.9	2.7
	5.0	4.1	12.1	3.5	11.3	3.3	10.5	3.0	10.1	2.9	9.7	2.8	8.9	2.6
	7.0	6.0	12.1	3.3	11.3	3.1	10.5	2.9	10.1	2.8	9.7	2.6	8.9	2.4
9.0	7.9	12.1	3.1	11.3	2.9	10.5	2.7	10.1	2.6	9.7	2.5	8.9	2.3	
11.0	9.8	12.1	2.9	11.3	2.7	10.5	2.6	10.1	2.5	9.7	2.4	8.9	2.2	
13.0	11.8	12.1	2.8	11.3	2.6	10.5	2.4	10.1	2.3	9.7	2.2	8.9	2.0	
15.0	13.7	12.1	2.6	11.3	2.4	10.5	2.3	10.1	2.2	9.7	2.1	8.9	1.9	
50%	-19.8	-20.0	10.1	5.3	9.4	5.0	8.8	4.6	8.4	4.5	8.1	4.3	7.4	4.0
	-18.8	-19.0	10.1	5.2	9.4	4.8	8.8	4.5	8.4	4.4	8.1	4.2	7.4	3.9
	-16.7	-17.0	10.1	4.9	9.4	4.6	8.8	4.3	8.4	4.2	8.1	4.0	7.4	3.7
	-13.7	-15.0	10.1	4.7	9.4	4.4	8.8	4.1	8.4	4.0	8.1	3.8	7.4	3.5
	-11.8	-13.0	10.1	4.5	9.4	4.2	8.8	3.9	8.4	3.8	8.1	3.6	7.4	3.4
	-9.8	-11.0	10.1	4.3	9.4	4.0	8.8	3.7	8.4	3.6	8.1	3.5	7.4	3.2
	-9.5	-10.0	10.1	4.2	9.4	3.9	8.8	3.6	8.4	3.5	8.1	3.4	7.4	3.1
	-8.5	-9.1	10.1	4.1	9.4	3.8	8.8	3.5	8.4	3.4	8.1	3.3	7.4	3.0
	-7.0	-7.6	10.1	3.9	9.4	3.7	8.8	3.4	8.4	3.3	8.1	3.2	7.4	2.9
	-5.0	-5.6	10.1	3.7	9.4	3.5	8.8	3.2	8.4	3.1	8.1	3.0	7.4	2.8
	-3.0	-3.7	10.1	3.5	9.4	3.3	8.8	3.1	8.4	3.0	8.1	2.9	7.4	2.6
	0.0	-0.7	10.1	3.3	9.4	3.0	8.8	2.8	8.4	2.7	8.1	2.6	7.4	2.4
	3.0	2.2	10.1	3.0	9.4	2.8	8.8	2.6	8.4	2.5	8.1	2.4	7.4	2.2
	5.0	4.1	10.1	2.8	9.4	2.7	8.8	2.5	8.4	2.4	8.1	2.3	7.4	2.1
	7.0	6.0	10.1	2.7	9.4	2.5	8.8	2.3	8.4	2.3	8.1	2.2	7.4	2.0
9.0	7.9	10.1	2.5	9.4	2.4	8.8	2.2	8.4	2.1	8.1	2.0	7.4	1.9	
11.0	9.8	10.1	2.4	9.4	2.2	8.8	2.1	8.4	2.0	8.1	1.9	7.4	1.8	
13.0	11.8	10.1	2.2	9.4	2.1	8.8	1.9	8.4	1.9	8.1	1.8	7.4	1.7	
15.0	13.7	10.1	2.1	9.4	2.0	8.8	1.8	8.4	1.8	8.1	1.7	7.4	1.6	

Abbreviations:

CR: Combination ratio

TC: Total capacity (kW)

PI: Power input (compressor + outdoor fan motor) (kW)

Notes:

Shaded cells indicate rating condition.

Table2-8.11:120 model heating capacity - 380-415V 3N~50Hz

CR	Outdoor air temp.		Indoor air temp. °C DB											
			16.0		18.0		20.0		21.0		22.0		24.0	
	°C DB	°C WB	TC kW	PI kW	TC kW	PI kW	TC kW	PI kW	TC kW	PI kW	TC kW	PI kW	TC kW	PI kW
130%	-19.8	-20.0	10.2	4.5	10.1	4.5	10.1	4.6	10.1	4.6	10.0	4.6	10.0	4.7
	-18.8	-19.0	10.6	4.5	10.5	4.5	10.4	4.6	10.4	4.6	10.4	4.7	10.3	4.8
	-16.7	-17.0	11.2	4.5	11.1	4.6	11.1	4.7	11.0	4.7	11.0	4.8	11.0	4.9
	-13.7	-15.0	11.9	4.6	11.8	4.7	11.7	4.7	11.7	4.8	11.7	4.8	11.6	5.0
	-11.8	-13.0	12.6	4.7	12.5	4.7	12.4	4.8	12.4	4.9	12.3	5.0	12.3	5.1
	-9.8	-11.0	13.3	4.7	13.2	4.8	13.1	4.9	13.1	5.0	13.0	5.1	13.0	5.2
	-9.5	-10.0	13.7	4.8	13.6	4.9	13.5	5.0	13.4	5.1	13.4	5.1	13.3	5.3
	-8.5	-9.1	14.0	4.8	13.9	4.9	13.8	5.1	13.7	5.1	13.7	5.2	13.6	5.3
	-7.0	-7.6	14.5	4.9	14.4	5.0	14.3	5.1	14.3	5.2	14.2	5.3	14.2	5.4
	-5.0	-5.6	15.3	5.0	15.2	5.1	15.0	5.3	15.0	5.4	15.0	5.4	14.9	5.6
	-3.0	-3.7	16.0	5.1	15.9	5.3	15.8	5.4	15.7	5.5	15.7	5.6	15.4	5.6
	0.0	-0.7	17.2	5.3	17.0	5.5	16.9	5.6	16.9	5.7	16.8	5.7	15.4	5.2
	3.0	2.2	18.3	5.5	18.2	5.7	18.2	5.9	17.5	5.6	16.8	5.3	15.4	4.8
	5.0	4.1	19.1	5.7	18.8	5.7	18.2	5.6	17.5	5.3	16.8	5.1	15.4	4.6
	7.0	6.0	19.7	5.7	19.6	5.8	18.2	5.3	17.5	5.1	16.8	4.8	15.4	4.3
9.0	7.9	20.3	5.7	19.6	5.5	18.2	5.1	17.5	4.8	16.8	4.6	15.4	4.1	
11.0	9.8	21.0	5.8	19.6	5.3	18.2	4.8	17.5	4.6	16.8	4.3	15.4	3.9	
13.0	11.8	21.0	5.4	19.6	5.0	18.2	4.5	17.5	4.3	16.8	4.1	15.4	3.7	
15.0	13.7	21.0	5.2	19.6	4.7	18.2	4.3	17.5	4.0	16.8	3.8	15.4	3.5	
120%	-19.8	-20.0	10.2	4.5	10.1	4.5	10.0	4.6	10.0	4.6	10.0	4.7	10.0	4.8
	-18.8	-19.0	10.5	4.5	10.4	4.6	10.4	4.6	10.3	4.7	10.3	4.7	10.3	4.8
	-16.7	-17.0	11.1	4.6	11.1	4.6	11.0	4.7	11.0	4.8	11.0	4.8	10.9	4.9
	-13.7	-15.0	11.8	4.6	11.7	4.7	11.7	4.8	11.6	4.9	11.6	4.9	11.6	5.0
	-11.8	-13.0	12.5	4.7	12.4	4.8	12.3	4.9	12.3	5.0	12.3	5.0	12.2	5.2
	-9.8	-11.0	13.2	4.8	13.1	4.9	13.0	5.0	13.0	5.1	12.9	5.1	12.9	5.3
	-9.5	-10.0	13.5	4.8	13.4	5.0	13.4	5.1	13.3	5.1	13.3	5.2	13.2	5.4
	-8.5	-9.1	13.9	4.9	13.8	5.0	13.7	5.1	13.6	5.2	13.6	5.3	13.5	5.4
	-7.0	-7.6	14.4	5.0	14.3	5.1	14.2	5.2	14.2	5.3	14.1	5.4	14.2	5.6
	-5.0	-5.6	15.1	5.1	15.0	5.2	14.9	5.4	14.9	5.5	14.8	5.5	14.2	5.3
	-3.0	-3.7	15.9	5.2	15.7	5.4	15.6	5.5	15.6	5.6	15.5	5.6	14.2	5.1
	0.0	-0.7	17.0	5.4	16.9	5.6	16.8	5.7	16.2	5.5	15.5	5.2	14.2	4.7
	3.0	2.2	18.2	5.7	18.1	5.8	16.8	5.3	16.2	5.1	15.5	4.8	14.2	4.4
	5.0	4.1	18.8	5.7	18.1	5.5	16.8	5.0	16.2	4.8	15.5	4.6	14.2	4.1
	7.0	6.0	19.4	5.7	18.1	5.2	16.8	4.8	16.2	4.6	15.5	4.4	14.2	3.9
9.0	7.9	19.4	5.4	18.1	5.0	16.8	4.5	16.2	4.3	15.5	4.1	14.2	3.7	
11.0	9.8	19.4	5.1	18.1	4.7	16.8	4.3	16.2	4.1	15.5	3.9	14.2	3.5	
13.0	11.8	19.4	4.8	18.1	4.4	16.8	4.0	16.2	3.8	15.5	3.7	14.2	3.3	
15.0	13.7	19.4	4.6	18.1	4.2	16.8	3.8	16.2	3.6	15.5	3.4	14.2	3.1	
110%	-19.8	-20.0	10.1	4.5	10.0	4.6	10.0	4.6	10.0	4.7	10.0	4.7	10.0	4.8
	-18.8	-19.0	10.4	4.5	10.3	4.6	10.3	4.7	10.3	4.7	10.3	4.8	10.3	4.9
	-16.7	-17.0	11.0	4.6	11.0	4.7	10.9	4.8	10.9	4.8	10.9	4.9	10.9	5.0
	-13.7	-15.0	11.7	4.7	11.6	4.8	11.6	4.9	11.6	4.9	11.5	5.0	11.5	5.1
	-11.8	-13.0	12.4	4.8	12.3	4.9	12.2	5.0	12.2	5.0	12.2	5.1	12.2	5.3
	-9.8	-11.0	13.1	4.9	13.0	5.0	12.9	5.1	12.9	5.2	12.9	5.2	13.0	5.5
	-9.5	-10.0	13.4	4.9	13.3	5.0	13.3	5.2	13.2	5.2	13.2	5.3	13.0	5.4
	-8.5	-9.1	13.7	5.0	13.6	5.1	13.6	5.2	13.5	5.3	13.5	5.4	13.0	5.2
	-7.0	-7.6	14.3	5.1	14.2	5.2	14.1	5.3	14.1	5.4	14.2	5.6	13.0	5.1
	-5.0	-5.6	15.0	5.2	14.9	5.3	14.8	5.5	14.8	5.5	14.2	5.3	13.0	4.8
	-3.0	-3.7	15.7	5.3	15.6	5.5	15.4	5.5	14.8	5.3	14.2	5.1	13.0	4.6
	0.0	-0.7	16.9	5.6	16.6	5.6	15.4	5.1	14.8	4.9	14.2	4.7	13.0	4.3
	3.0	2.2	17.8	5.6	16.6	5.2	15.4	4.7	14.8	4.5	14.2	4.3	13.0	3.9
	5.0	4.1	17.8	5.3	16.6	4.9	15.4	4.5	14.8	4.3	14.2	4.1	13.0	3.7
	7.0	6.0	17.8	5.1	16.6	4.7	15.4	4.3	14.8	4.1	14.2	3.9	13.0	3.5
9.0	7.9	17.8	4.8	16.6	4.4	15.4	4.0	14.8	3.9	14.2	3.7	13.0	3.4	
11.0	9.8	17.8	4.5	16.6	4.2	15.4	3.8	14.8	3.6	14.2	3.5	13.0	3.2	
13.0	11.8	17.8	4.3	16.6	3.9	15.4	3.6	14.8	3.4	14.2	3.3	13.0	3.0	
15.0	13.7	17.8	4.0	16.6	3.7	15.4	3.4	14.8	3.2	14.2	3.1	13.0	2.8	

Abbreviations:

CR: Combination ratio

TC: Total capacity (kW)

PI: Power input (compressor + outdoor fan motor) (kW)

Notes:

Shaded cells indicate rating condition.

Table continued on next page ...

Table2-8.11:120 model heating capacity - 380-415V 3N~50Hz (continued)

CR	Outdoor air temp.		Indoor air temp. °C DB											
			16.0		18.0		20.0		21.0		22.0		24.0	
			TC	PI	TC	PI	TC	PI	TC	PI	TC	PI	TC	PI
100%	°C DB	°C WB	kW	kW	kW	kW	kW	kW	kW	kW	kW	kW	kW	kW
	-19.8	-20.0	10.0	4.6	10.0	4.6	9.9	4.7	9.9	4.7	9.9	4.8	10.0	4.9
	-18.8	-19.0	10.3	4.6	10.3	4.6	10.2	4.7	10.2	4.8	10.2	4.8	10.3	5.0
	-16.7	-17.0	11.0	4.7	10.9	4.7	10.9	4.8	10.9	4.9	10.9	4.9	10.9	5.1
	-13.7	-15.0	11.6	4.7	11.5	4.8	11.5	4.9	11.5	5.0	11.5	5.1	11.5	5.2
	-11.8	-13.0	12.3	4.8	12.2	4.9	12.2	5.1	12.1	5.1	12.1	5.2	11.8	5.2
	-9.8	-11.0	13.0	5.0	12.9	5.1	12.8	5.2	12.8	5.3	12.9	5.4	11.8	4.9
	-9.5	-10.0	13.3	5.0	13.2	5.1	13.2	5.3	13.1	5.4	12.9	5.3	11.8	4.8
	-8.5	-9.1	13.6	5.1	13.5	5.2	13.5	5.4	13.5	5.4	12.9	5.2	11.8	4.7
	-7.0	-7.6	14.1	5.2	14.1	5.3	14.0	5.4	13.5	5.2	12.9	5.0	11.8	4.5
	-5.0	-5.6	14.9	5.3	15.1	5.6	14.0	5.2	13.5	5.0	12.9	4.7	11.8	4.3
	-3.0	-3.7	15.6	5.5	15.1	5.3	14.0	4.9	13.5	4.7	12.9	4.5	11.8	4.1
	0.0	-0.7	16.2	5.3	15.1	5.0	14.0	4.6	13.5	4.4	12.9	4.2	11.8	3.8
	3.0	2.2	16.2	5.0	15.1	4.6	14.0	4.2	13.5	4.0	12.9	3.9	11.8	3.5
	5.0	4.1	16.2	4.7	15.1	4.4	14.0	4.0	13.5	3.8	12.9	3.7	11.8	3.3
7.0	6.0	16.2	4.5	15.1	4.1	14.0	3.8	13.5	3.6	12.9	3.5	11.8	3.2	
9.0	7.9	16.2	4.2	15.1	3.9	14.0	3.6	13.5	3.4	12.9	3.3	11.8	3.0	
11.0	9.8	16.2	4.0	15.1	3.7	14.0	3.4	13.5	3.2	12.9	3.1	11.8	2.8	
13.0	11.8	16.2	3.7	15.1	3.5	14.0	3.2	13.5	3.0	12.9	2.9	11.8	2.7	
15.0	13.7	16.2	3.5	15.1	3.3	14.0	3.0	13.5	2.9	12.9	2.8	11.8	2.5	
90%	-19.8	-20.0	9.9	4.6	9.9	4.7	9.9	4.8	9.9	4.8	9.9	4.9	10.0	5.0
	-18.8	-19.0	10.2	4.6	10.2	4.7	10.2	4.8	10.2	4.9	10.2	4.9	10.3	5.1
	-16.7	-17.0	10.9	4.7	10.8	4.8	10.8	4.9	10.8	5.0	10.8	5.1	10.7	5.1
	-13.7	-15.0	11.5	4.8	11.5	4.9	11.4	5.1	11.4	5.1	11.6	5.3	10.7	4.8
	-11.8	-13.0	12.2	4.9	12.1	5.1	12.1	5.2	12.1	5.3	11.6	5.0	10.7	4.6
	-9.8	-11.0	12.8	5.1	12.8	5.2	12.6	5.2	12.1	5.0	11.6	4.8	10.7	4.4
	-9.5	-10.0	13.2	5.1	13.1	5.3	12.6	5.1	12.1	4.9	11.6	4.7	10.7	4.3
	-8.5	-9.1	13.5	5.2	13.6	5.4	12.6	5.0	12.1	4.8	11.6	4.6	10.7	4.2
	-7.0	-7.6	14.0	5.3	13.6	5.2	12.6	4.8	12.1	4.6	11.6	4.4	10.7	4.1
	-5.0	-5.6	14.5	5.3	13.6	4.9	12.6	4.6	12.1	4.4	11.6	4.2	10.7	3.8
	-3.0	-3.7	14.5	5.1	13.6	4.7	12.6	4.4	12.1	4.2	11.6	4.0	10.7	3.7
	0.0	-0.7	14.5	4.7	13.6	4.4	12.6	4.0	12.1	3.9	11.6	3.7	10.7	3.4
	3.0	2.2	14.5	4.3	13.6	4.0	12.6	3.7	12.1	3.6	11.6	3.4	10.7	3.1
	5.0	4.1	14.5	4.1	13.6	3.8	12.6	3.5	12.1	3.4	11.6	3.2	10.7	3.0
	7.0	6.0	14.5	3.9	13.6	3.6	12.6	3.3	12.1	3.2	11.6	3.1	10.7	2.8
9.0	7.9	14.5	3.7	13.6	3.4	12.6	3.2	12.1	3.0	11.6	2.9	10.7	2.7	
11.0	9.8	14.5	3.5	13.6	3.2	12.6	3.0	12.1	2.9	11.6	2.7	10.7	2.5	
13.0	11.8	14.5	3.3	13.6	3.0	12.6	2.8	12.1	2.7	11.6	2.6	10.7	2.3	
15.0	13.7	14.5	3.1	13.6	2.8	12.6	2.6	12.1	2.5	11.6	2.4	10.7	2.2	
80%	-19.8	-20.0	9.9	4.7	9.9	4.8	9.9	4.9	9.9	4.9	9.9	5.0	9.5	4.8
	-18.8	-19.0	10.2	4.7	10.2	4.8	10.2	4.9	10.2	5.0	10.3	5.1	9.5	4.7
	-16.7	-17.0	10.8	4.8	10.8	4.9	10.8	5.1	10.8	5.1	10.3	4.9	9.5	4.5
	-13.7	-15.0	11.4	4.9	11.4	5.1	11.2	5.0	10.8	4.9	10.3	4.7	9.5	4.3
	-11.8	-13.0	12.1	5.1	12.1	5.2	11.2	4.8	10.8	4.6	10.3	4.4	9.5	4.1
	-9.8	-11.0	12.9	5.3	12.1	4.9	11.2	4.6	10.8	4.4	10.3	4.2	9.5	3.9
	-9.5	-10.0	12.9	5.2	12.1	4.8	11.2	4.5	10.8	4.3	10.3	4.1	9.5	3.8
	-8.5	-9.1	12.9	5.1	12.1	4.7	11.2	4.4	10.8	4.2	10.3	4.0	9.5	3.7
	-7.0	-7.6	12.9	4.9	12.1	4.5	11.2	4.2	10.8	4.0	10.3	3.9	9.5	3.6
	-5.0	-5.6	12.9	4.6	12.1	4.3	11.2	4.0	10.8	3.8	10.3	3.7	9.5	3.4
	-3.0	-3.7	12.9	4.4	12.1	4.1	11.2	3.8	10.8	3.7	10.3	3.5	9.5	3.2
	0.0	-0.7	12.9	4.1	12.1	3.8	11.2	3.5	10.8	3.4	10.3	3.2	9.5	3.0
	3.0	2.2	12.9	3.8	12.1	3.5	11.2	3.2	10.8	3.1	10.3	3.0	9.5	2.7
	5.0	4.1	12.9	3.5	12.1	3.3	11.2	3.1	10.8	2.9	10.3	2.8	9.5	2.6
	7.0	6.0	12.9	3.4	12.1	3.1	11.2	2.9	10.8	2.8	10.3	2.7	9.5	2.5
9.0	7.9	12.9	3.2	12.1	3.0	11.2	2.7	10.8	2.6	10.3	2.5	9.5	2.3	
11.0	9.8	12.9	3.0	12.1	2.8	11.2	2.6	10.8	2.5	10.3	2.4	9.5	2.2	
13.0	11.8	12.9	2.8	12.1	2.6	11.2	2.4	10.8	2.3	10.3	2.2	9.5	2.0	
15.0	13.7	12.9	2.7	12.1	2.5	11.2	2.3	10.8	2.2	10.3	2.1	9.5	1.9	

Abbreviations:
CR: Combination ratio
TC: Total capacity (kW)
PI: Power input (compressor + outdoor fan motor) (kW)
Notes:
Shaded cells indicate rating condition.

Table continued on next page ...

Table2-8.11:120 model heating capacity - 380-415V 3N~50Hz (continued)

CR	Outdoor air temp.		Indoor air temp. °C DB											
			16.0		18.0		20.0		21.0		22.0		24.0	
	°C DB	°C WB	TC	PI	TC	PI	TC	PI	TC	PI	TC	PI	TC	PI
70%	-19.8	-20.0	9.8	4.8	9.9	4.9	9.8	4.9	9.4	4.7	9.0	4.6	8.3	4.2
	-18.8	-19.0	10.1	4.8	10.2	5.0	9.8	4.8	9.4	4.6	9.0	4.5	8.3	4.1
	-16.7	-17.0	10.8	5.0	10.6	4.9	9.8	4.6	9.4	4.4	9.0	4.3	8.3	3.9
	-13.7	-15.0	11.3	5.0	10.6	4.7	9.8	4.4	9.4	4.2	9.0	4.1	8.3	3.7
	-11.8	-13.0	11.3	4.8	10.6	4.5	9.8	4.2	9.4	4.0	9.0	3.9	8.3	3.6
	-9.8	-11.0	11.3	4.6	10.6	4.3	9.8	4.0	9.4	3.8	9.0	3.7	8.3	3.4
	-9.5	-10.0	11.3	4.5	10.6	4.2	9.8	3.9	9.4	3.7	9.0	3.6	8.3	3.3
	-8.5	-9.1	11.3	4.3	10.6	4.1	9.8	3.8	9.4	3.6	9.0	3.5	8.3	3.2
	-7.0	-7.6	11.3	4.2	10.6	3.9	9.8	3.6	9.4	3.5	9.0	3.4	8.3	3.1
	-5.0	-5.6	11.3	4.0	10.6	3.7	9.8	3.5	9.4	3.3	9.0	3.2	8.3	2.9
	-3.0	-3.7	11.3	3.8	10.6	3.5	9.8	3.3	9.4	3.2	9.0	3.0	8.3	2.8
	0.0	-0.7	11.3	3.5	10.6	3.2	9.8	3.0	9.4	2.9	9.0	2.8	8.3	2.6
	3.0	2.2	11.3	3.2	10.6	3.0	9.8	2.8	9.4	2.7	9.0	2.6	8.3	2.4
	5.0	4.1	11.3	3.0	10.6	2.8	9.8	2.6	9.4	2.5	9.0	2.4	8.3	2.3
	7.0	6.0	11.3	2.9	10.6	2.7	9.8	2.5	9.4	2.4	9.0	2.3	8.3	2.1
9.0	7.9	11.3	2.7	10.6	2.5	9.8	2.4	9.4	2.3	9.0	2.2	8.3	2.0	
11.0	9.8	11.3	2.5	10.6	2.4	9.8	2.2	9.4	2.1	9.0	2.0	8.3	1.9	
13.0	11.8	11.3	2.4	10.6	2.2	9.8	2.1	9.4	2.0	9.0	1.9	8.3	1.8	
15.0	13.7	11.3	2.3	10.6	2.1	9.8	1.9	9.4	1.9	9.0	1.8	8.3	1.7	
60%	-19.8	-20.0	9.7	4.8	9.0	4.5	8.4	4.2	8.1	4.1	7.8	3.9	7.1	3.6
	-18.8	-19.0	9.7	4.7	9.0	4.4	8.4	4.1	8.1	4.0	7.8	3.8	7.1	3.6
	-16.7	-17.0	9.7	4.5	9.0	4.2	8.4	3.9	8.1	3.8	7.8	3.7	7.1	3.4
	-13.7	-15.0	9.7	4.3	9.0	4.0	8.4	3.7	8.1	3.6	7.8	3.5	7.1	3.2
	-11.8	-13.0	9.7	4.1	9.0	3.8	8.4	3.5	8.1	3.4	7.8	3.3	7.1	3.1
	-9.8	-11.0	9.7	3.8	9.0	3.6	8.4	3.4	8.1	3.3	7.8	3.1	7.1	2.9
	-9.5	-10.0	9.7	3.7	9.0	3.5	8.4	3.3	8.1	3.2	7.8	3.1	7.1	2.8
	-8.5	-9.1	9.7	3.7	9.0	3.4	8.4	3.2	8.1	3.1	7.8	3.0	7.1	2.8
	-7.0	-7.6	9.7	3.5	9.0	3.3	8.4	3.1	8.1	3.0	7.8	2.9	7.1	2.7
	-5.0	-5.6	9.7	3.3	9.0	3.1	8.4	2.9	8.1	2.8	7.8	2.7	7.1	2.5
	-3.0	-3.7	9.7	3.2	9.0	3.0	8.4	2.8	8.1	2.7	7.8	2.6	7.1	2.4
	0.0	-0.7	9.7	2.9	9.0	2.7	8.4	2.6	8.1	2.5	7.8	2.4	7.1	2.2
	3.0	2.2	9.7	2.7	9.0	2.5	8.4	2.4	8.1	2.3	7.8	2.2	7.1	2.0
	5.0	4.1	9.7	2.5	9.0	2.4	8.4	2.2	8.1	2.1	7.8	2.1	7.1	1.9
	7.0	6.0	9.7	2.4	9.0	2.3	8.4	2.1	8.1	2.0	7.8	2.0	7.1	1.8
9.0	7.9	9.7	2.3	9.0	2.1	8.4	2.0	8.1	1.9	7.8	1.8	7.1	1.7	
11.0	9.8	9.7	2.1	9.0	2.0	8.4	1.9	8.1	1.8	7.8	1.7	7.1	1.6	
13.0	11.8	9.7	2.0	9.0	1.9	8.4	1.8	8.1	1.7	7.8	1.6	7.1	1.5	
15.0	13.7	9.7	1.9	9.0	1.7	8.4	1.6	8.1	1.6	7.8	1.5	7.1	1.4	
50%	-19.8	-20.0	8.1	4.0	7.5	3.8	7.0	3.5	6.7	3.4	6.5	3.3	5.9	3.1
	-18.8	-19.0	8.1	3.9	7.5	3.7	7.0	3.4	6.7	3.3	6.5	3.2	5.9	3.0
	-16.7	-17.0	8.1	3.7	7.5	3.5	7.0	3.3	6.7	3.2	6.5	3.1	5.9	2.8
	-13.7	-15.0	8.1	3.5	7.5	3.3	7.0	3.1	6.7	3.0	6.5	2.9	5.9	2.7
	-11.8	-13.0	8.1	3.3	7.5	3.1	7.0	3.0	6.7	2.9	6.5	2.8	5.9	2.6
	-9.8	-11.0	8.1	3.2	7.5	3.0	7.0	2.8	6.7	2.7	6.5	2.6	5.9	2.4
	-9.5	-10.0	8.1	3.1	7.5	2.9	7.0	2.7	6.7	2.6	6.5	2.5	5.9	2.4
	-8.5	-9.1	8.1	3.0	7.5	2.8	7.0	2.7	6.7	2.6	6.5	2.5	5.9	2.3
	-7.0	-7.6	8.1	2.9	7.5	2.7	7.0	2.6	6.7	2.5	6.5	2.4	5.9	2.2
	-5.0	-5.6	8.1	2.8	7.5	2.6	7.0	2.4	6.7	2.3	6.5	2.3	5.9	2.1
	-3.0	-3.7	8.1	2.6	7.5	2.5	7.0	2.3	6.7	2.2	6.5	2.1	5.9	2.0
	0.0	-0.7	8.1	2.4	7.5	2.3	7.0	2.1	6.7	2.0	6.5	2.0	5.9	1.8
	3.0	2.2	8.1	2.2	7.5	2.1	7.0	1.9	6.7	1.9	6.5	1.8	5.9	1.7
	5.0	4.1	8.1	2.1	7.5	2.0	7.0	1.8	6.7	1.8	6.5	1.7	5.9	1.6
	7.0	6.0	8.1	2.0	7.5	1.8	7.0	1.7	6.7	1.7	6.5	1.6	5.9	1.5
9.0	7.9	8.1	1.8	7.5	1.7	7.0	1.6	6.7	1.6	6.5	1.5	5.9	1.4	
11.0	9.8	8.1	1.7	7.5	1.7	7.0	1.6	6.7	1.5	6.5	1.5	5.9	1.4	
13.0	11.8	8.1	1.6	7.5	1.6	7.0	1.5	6.7	1.4	6.5	1.4	5.9	1.3	
15.0	13.7	8.1	1.5	7.5	1.4	7.0	1.4	6.7	1.3	6.5	1.3	5.9	1.2	

Abbreviations:

CR: Combination ratio

TC: Total capacity (kW)

PI: Power input (compressor + outdoor fan motor) (kW)

Notes:

Shaded cells indicate rating condition.

Table2-8.12:140 model heating capacity - 380-415V 3N~50Hz

CR	Outdoor air temp.		Indoor air temp. °C DB											
			16.0		18.0		20.0		21.0		22.0		24.0	
	°C DB	°C WB	TC	PI	TC	PI	TC	PI	TC	PI	TC	PI	TC	PI
130%	-19.8	-20.0	10.6	4.6	10.5	4.7	10.4	4.7	10.3	4.8	10.3	4.8	10.3	4.9
	-18.8	-19.0	10.9	4.7	10.8	4.7	10.7	4.8	10.7	4.8	10.6	4.8	10.6	4.9
	-16.7	-17.0	11.6	4.7	11.5	4.8	11.4	4.8	11.4	4.9	11.3	4.9	11.3	5.0
	-13.7	-15.0	12.3	4.8	12.2	4.8	12.1	4.9	12.1	5.0	12.0	5.0	11.9	5.2
	-11.8	-13.0	13.0	4.8	12.9	4.9	12.8	5.0	12.8	5.1	12.7	5.2	12.6	5.3
	-9.8	-11.0	13.7	4.9	13.6	5.0	13.5	5.1	13.5	5.2	13.4	5.3	13.3	5.4
	-9.5	-10.0	14.1	5.0	14.0	5.1	13.9	5.2	13.8	5.3	13.8	5.3	13.7	5.5
	-8.5	-9.1	14.4	5.0	14.3	5.1	14.2	5.3	14.2	5.3	14.1	5.4	14.0	5.5
	-7.0	-7.6	15.0	5.1	14.9	5.2	14.8	5.3	14.7	5.4	14.7	5.5	14.6	5.7
	-5.0	-5.6	15.8	5.2	15.6	5.3	15.5	5.5	15.5	5.6	15.4	5.6	15.3	5.8
	-3.0	-3.7	16.5	5.3	16.4	5.5	16.2	5.6	16.2	5.7	16.1	5.8	16.0	6.0
	0.0	-0.7	17.7	5.5	17.6	5.7	17.4	5.8	17.4	5.9	17.3	6.0	17.2	6.2
	3.0	2.2	18.9	5.7	18.7	5.9	18.6	6.1	18.5	6.2	18.5	6.3	17.6	5.9
	5.0	4.1	19.7	5.9	19.5	6.1	19.4	6.3	19.3	6.4	19.2	6.3	17.6	5.7
	7.0	6.0	20.5	6.0	20.3	6.2	20.1	6.4	20.0	6.3	19.2	6.0	17.6	5.4
9.0	7.9	21.3	6.2	21.1	6.4	20.8	6.3	20.0	6.0	19.2	5.7	17.6	5.1	
11.0	9.8	22.2	6.4	21.7	6.4	20.8	6.0	20.0	5.7	19.2	5.4	17.6	4.9	
13.0	11.8	22.8	6.4	22.4	6.3	20.8	5.7	20.0	5.4	19.2	5.1	17.6	4.6	
15.0	13.7	23.3	6.4	22.4	6.0	20.8	5.4	20.0	5.1	19.2	4.9	17.6	4.3	
120%	-19.8	-20.0	10.5	4.7	10.4	4.7	10.3	4.8	10.3	4.8	10.3	4.8	10.2	4.9
	-18.8	-19.0	10.8	4.7	10.7	4.7	10.6	4.8	10.6	4.8	10.6	4.9	10.5	5.0
	-16.7	-17.0	11.5	4.7	11.4	4.8	11.3	4.9	11.3	4.9	11.3	5.0	11.2	5.1
	-13.7	-15.0	12.2	4.8	12.1	4.9	12.0	5.0	12.0	5.0	11.9	5.1	11.9	5.2
	-11.8	-13.0	12.9	4.9	12.8	5.0	12.7	5.1	12.7	5.2	12.6	5.2	12.6	5.3
	-9.8	-11.0	13.6	5.0	13.5	5.1	13.4	5.2	13.4	5.3	13.3	5.3	13.2	5.5
	-9.5	-10.0	14.0	5.0	13.9	5.1	13.8	5.3	13.7	5.3	13.7	5.4	13.6	5.6
	-8.5	-9.1	14.3	5.1	14.2	5.2	14.1	5.3	14.0	5.4	14.0	5.5	13.9	5.6
	-7.0	-7.6	14.9	5.2	14.7	5.3	14.6	5.4	14.6	5.5	14.5	5.6	14.4	5.7
	-5.0	-5.6	15.6	5.3	15.5	5.4	15.4	5.6	15.3	5.7	15.3	5.7	15.2	5.9
	-3.0	-3.7	16.3	5.4	16.2	5.6	16.1	5.7	16.0	5.8	16.0	5.9	15.9	6.1
	0.0	-0.7	17.5	5.6	17.4	5.8	17.3	6.0	17.2	6.1	17.1	6.2	16.2	5.8
	3.0	2.2	18.7	5.9	18.6	6.0	18.4	6.2	18.5	6.3	17.7	6.0	16.2	5.4
	5.0	4.1	19.5	6.0	19.4	6.2	19.2	6.3	18.5	6.0	17.7	5.7	16.2	5.1
	7.0	6.0	20.3	6.2	20.1	6.4	19.2	6.0	18.5	5.7	17.7	5.4	16.2	4.9
9.0	7.9	21.1	6.4	20.7	6.3	19.2	5.7	18.5	5.4	17.7	5.1	16.2	4.6	
11.0	9.8	21.7	6.4	20.7	5.9	19.2	5.4	18.5	5.1	17.7	4.9	16.2	4.3	
13.0	11.8	22.2	6.2	20.7	5.6	19.2	5.1	18.5	4.8	17.7	4.6	16.2	4.1	
15.0	13.7	22.2	5.9	20.7	5.3	19.2	4.8	18.5	4.6	17.7	4.3	16.2	3.9	
110%	-19.8	-20.0	10.4	4.7	10.3	4.7	10.2	4.8	10.2	4.8	10.2	4.9	10.2	5.0
	-18.8	-19.0	10.7	4.7	10.6	4.8	10.6	4.8	10.5	4.9	10.5	4.9	10.5	5.0
	-16.7	-17.0	11.4	4.8	11.3	4.8	11.2	4.9	11.2	5.0	11.2	5.0	11.1	5.2
	-13.7	-15.0	12.1	4.9	12.0	4.9	11.9	5.0	11.9	5.1	11.8	5.2	11.8	5.3
	-11.8	-13.0	12.8	4.9	12.7	5.0	12.6	5.2	12.5	5.2	12.5	5.3	12.5	5.4
	-9.8	-11.0	13.5	5.0	13.4	5.2	13.3	5.3	13.2	5.4	13.2	5.4	13.1	5.6
	-9.5	-10.0	13.8	5.1	13.7	5.2	13.6	5.4	13.6	5.4	13.6	5.5	13.5	5.7
	-8.5	-9.1	14.2	5.2	14.0	5.3	14.0	5.4	13.9	5.5	13.9	5.6	13.8	5.7
	-7.0	-7.6	14.7	5.3	14.6	5.4	14.5	5.5	14.5	5.6	14.4	5.7	14.3	5.9
	-5.0	-5.6	15.5	5.4	15.3	5.5	15.2	5.7	15.2	5.8	15.1	5.9	14.9	5.8
	-3.0	-3.7	16.2	5.5	16.1	5.7	15.9	5.9	15.9	5.9	15.9	6.0	14.9	5.6
	0.0	-0.7	17.4	5.8	17.2	5.9	17.1	6.1	16.9	6.0	16.2	5.7	14.9	5.2
	3.0	2.2	18.5	6.0	18.4	6.2	17.6	5.9	16.9	5.6	16.2	5.3	14.9	4.8
	5.0	4.1	19.3	6.2	19.0	6.1	17.6	5.6	16.9	5.3	16.2	5.1	14.9	4.6
	7.0	6.0	20.3	6.4	19.0	5.8	17.6	5.3	16.9	5.1	16.2	4.8	14.9	4.3
9.0	7.9	20.3	6.1	19.0	5.6	17.6	5.1	16.9	4.8	16.2	4.6	14.9	4.1	
11.0	9.8	20.3	5.8	19.0	5.3	17.6	4.8	16.9	4.6	16.2	4.3	14.9	3.9	
13.0	11.8	20.3	5.5	19.0	5.0	17.6	4.5	16.9	4.3	16.2	4.1	14.9	3.7	
15.0	13.7	20.3	5.2	19.0	4.7	17.6	4.3	16.9	4.0	16.2	3.8	14.9	3.5	

Abbreviations:

CR: Combination ratio

TC: Total capacity (kW)

PI: Power input (compressor + outdoor fan motor) (kW)

Notes:

Shaded cells indicate rating condition.

Table continued on next page ...

Table 2-8.12:140 model heating capacity - 380-415V 3N~50Hz (continued)

CR	Outdoor air temp.		Indoor air temp. °C DB											
			16.0		18.0		20.0		21.0		22.0		24.0	
	°C DB	°C WB	TC	PI	TC	PI	TC	PI	TC	PI	TC	PI	TC	PI
100%	-19.8	-20.0	10.3	4.7	10.2	4.8	10.2	4.8	10.1	4.9	10.1	4.9	10.1	5.1
	-18.8	-19.0	10.6	4.7	10.5	4.8	10.5	4.9	10.5	4.9	10.5	5.0	10.4	5.1
	-16.7	-17.0	11.3	4.8	11.2	4.9	11.1	5.0	11.1	5.1	11.1	5.1	11.1	5.3
	-13.7	-15.0	11.9	4.9	11.9	5.0	11.8	5.1	11.8	5.2	11.8	5.2	11.7	5.4
	-11.8	-13.0	12.6	5.0	12.5	5.1	12.5	5.3	12.4	5.3	12.4	5.4	12.4	5.5
	-9.8	-11.0	13.3	5.1	13.2	5.3	13.2	5.4	13.1	5.5	13.1	5.5	13.1	5.7
	-9.5	-10.0	13.7	5.2	13.6	5.3	13.5	5.5	13.5	5.5	13.5	5.6	13.5	5.8
	-8.5	-9.1	14.0	5.3	13.9	5.4	13.8	5.5	13.8	5.6	13.8	5.7	13.5	5.7
	-7.0	-7.6	14.6	5.4	14.5	5.5	14.4	5.7	14.3	5.7	14.3	5.8	13.5	5.5
	-5.0	-5.6	15.3	5.5	15.2	5.7	15.1	5.8	15.1	5.9	14.8	5.8	13.5	5.2
	-3.0	-3.7	16.0	5.7	15.9	5.8	16.0	6.1	15.4	5.8	14.8	5.5	13.5	5.0
	0.0	-0.7	17.2	5.9	17.2	6.1	16.0	5.6	15.4	5.4	14.8	5.1	13.5	4.6
	3.0	2.2	18.5	6.2	17.2	5.7	16.0	5.2	15.4	5.0	14.8	4.7	13.5	4.3
	5.0	4.1	18.5	5.9	17.2	5.4	16.0	5.0	15.4	4.7	14.8	4.5	13.5	4.1
	7.0	6.0	18.5	5.6	17.2	5.1	16.0	4.7	15.4	4.5	14.8	4.3	13.5	3.9
9.0	7.9	18.5	5.3	17.2	4.9	16.0	4.5	15.4	4.2	14.8	4.0	13.5	3.7	
11.0	9.8	18.5	5.0	17.2	4.6	16.0	4.2	15.4	4.0	14.8	3.8	13.5	3.5	
13.0	11.8	18.5	4.8	17.2	4.3	16.0	4.0	15.4	3.8	14.8	3.6	13.5	3.3	
15.0	13.7	18.5	4.5	17.2	4.1	16.0	3.7	15.4	3.6	14.8	3.4	13.5	3.1	
90%	-19.8	-20.0	10.2	4.7	10.1	4.8	10.1	4.9	10.1	5.0	10.1	5.0	10.1	5.1
	-18.8	-19.0	10.5	4.8	10.4	4.9	10.4	5.0	10.4	5.0	10.4	5.1	10.4	5.2
	-16.7	-17.0	11.2	4.9	11.1	5.0	11.1	5.1	11.0	5.2	11.0	5.2	11.0	5.4
	-13.7	-15.0	11.8	5.0	11.8	5.1	11.7	5.2	11.7	5.3	11.7	5.4	11.7	5.5
	-11.8	-13.0	12.5	5.1	12.4	5.2	12.4	5.4	12.4	5.4	12.3	5.5	12.2	5.5
	-9.8	-11.0	13.2	5.2	13.1	5.4	13.1	5.5	13.0	5.6	13.0	5.7	12.2	5.3
	-9.5	-10.0	13.6	5.3	13.5	5.5	13.4	5.6	13.4	5.7	13.3	5.7	12.2	5.2
	-8.5	-9.1	13.9	5.4	13.8	5.5	13.7	5.7	13.8	5.8	13.3	5.5	12.2	5.1
	-7.0	-7.6	14.4	5.5	14.3	5.7	14.4	5.9	13.8	5.6	13.3	5.4	12.2	4.9
	-5.0	-5.6	15.1	5.7	15.0	5.8	14.4	5.6	13.8	5.3	13.3	5.1	12.2	4.7
	-3.0	-3.7	15.8	5.9	15.5	5.8	14.4	5.3	13.8	5.1	13.3	4.9	12.2	4.4
	0.0	-0.7	16.6	5.8	15.5	5.4	14.4	4.9	13.8	4.7	13.3	4.5	12.2	4.1
	3.0	2.2	16.6	5.4	15.5	5.0	14.4	4.6	13.8	4.4	13.3	4.2	12.2	3.8
	5.0	4.1	16.6	5.1	15.5	4.7	14.4	4.3	13.8	4.1	13.3	4.0	12.2	3.6
	7.0	6.0	16.6	4.9	15.5	4.5	14.4	4.1	13.8	3.9	13.3	3.7	12.2	3.4
9.0	7.9	16.6	4.6	15.5	4.2	14.4	3.9	13.8	3.7	13.3	3.6	12.2	3.2	
11.0	9.8	16.6	4.4	15.5	4.0	14.4	3.7	13.8	3.5	13.3	3.4	12.2	3.1	
13.0	11.8	16.6	4.1	15.5	3.8	14.4	3.5	13.8	3.3	13.3	3.2	12.2	2.9	
15.0	13.7	16.6	3.9	15.5	3.6	14.4	3.3	13.8	3.1	13.3	3.0	12.2	2.7	
80%	-19.8	-20.0	10.1	4.8	10.1	4.9	10.0	5.0	10.0	5.1	10.0	5.1	10.1	5.3
	-18.8	-19.0	10.4	4.9	10.4	5.0	10.4	5.1	10.4	5.1	10.4	5.2	10.4	5.4
	-16.7	-17.0	11.1	5.0	11.0	5.1	11.0	5.2	11.0	5.3	11.0	5.4	10.8	5.3
	-13.7	-15.0	11.7	5.1	11.7	5.2	11.6	5.4	11.6	5.4	11.8	5.6	10.8	5.1
	-11.8	-13.0	12.4	5.2	12.3	5.4	12.3	5.5	12.3	5.6	11.8	5.3	10.8	4.9
	-9.8	-11.0	13.1	5.4	13.0	5.6	12.8	5.5	12.3	5.3	11.8	5.1	10.8	4.7
	-9.5	-10.0	13.4	5.5	13.3	5.6	12.8	5.4	12.3	5.2	11.8	5.0	10.8	4.6
	-8.5	-9.1	13.7	5.6	13.8	5.7	12.8	5.3	12.3	5.1	11.8	4.9	10.8	4.5
	-7.0	-7.6	14.3	5.7	13.8	5.5	12.8	5.1	12.3	4.9	11.8	4.7	10.8	4.3
	-5.0	-5.6	14.8	5.7	13.8	5.3	12.8	4.9	12.3	4.7	11.8	4.5	10.8	4.1
	-3.0	-3.7	14.8	5.4	13.8	5.0	12.8	4.6	12.3	4.4	11.8	4.3	10.8	3.9
	0.0	-0.7	14.8	5.0	13.8	4.6	12.8	4.3	12.3	4.1	11.8	3.9	10.8	3.6
	3.0	2.2	14.8	4.6	13.8	4.3	12.8	4.0	12.3	3.8	11.8	3.6	10.8	3.3
	5.0	4.1	14.8	4.4	13.8	4.1	12.8	3.8	12.3	3.6	11.8	3.5	10.8	3.2
	7.0	6.0	14.8	4.2	13.8	3.9	12.8	3.6	12.3	3.4	11.8	3.3	10.8	3.0
9.0	7.9	14.8	3.9	13.8	3.7	12.8	3.4	12.3	3.2	11.8	3.1	10.8	2.8	
11.0	9.8	14.8	3.7	13.8	3.5	12.8	3.2	12.3	3.1	11.8	2.9	10.8	2.7	
13.0	11.8	14.8	3.5	13.8	3.2	12.8	3.0	12.3	2.9	11.8	2.7	10.8	2.5	
15.0	13.7	14.8	3.3	13.8	3.1	12.8	2.8	12.3	2.7	11.8	2.6	10.8	2.4	

Abbreviations:

CR: Combination ratio

TC: Total capacity (kW)

PI: Power input (compressor + outdoor fan motor) (kW)

Notes:

Shaded cells indicate rating condition.

Table continued on next page ...

Table2-8.12:140 model heating capacity - 380-415V 3N~50Hz (continued)

CR	Outdoor air temp.		Indoor air temp. °C DB											
			16.0		18.0		20.0		21.0		22.0		24.0	
	°C DB	°C WB	TC	PI	TC	PI	TC	PI	TC	PI	TC	PI	TC	PI
70%	-19.8	-20.0	10.0	4.9	10.0	5.0	10.0	5.1	10.0	5.2	10.1	5.3	9.5	5.0
	-18.8	-19.0	10.3	5.0	10.3	5.1	10.3	5.2	10.3	5.3	10.3	5.3	9.5	4.9
	-16.7	-17.0	11.0	5.1	10.9	5.2	10.9	5.4	10.8	5.3	10.3	5.1	9.5	4.7
	-13.7	-15.0	11.6	5.3	11.6	5.4	11.2	5.2	10.8	5.0	10.3	4.8	9.5	4.5
	-11.8	-13.0	12.3	5.4	12.1	5.4	11.2	5.0	10.8	4.8	10.3	4.6	9.5	4.3
	-9.8	-11.0	12.9	5.5	12.1	5.1	11.2	4.8	10.8	4.6	10.3	4.4	9.5	4.1
	-9.5	-10.0	12.9	5.4	12.1	5.0	11.2	4.7	10.8	4.5	10.3	4.3	9.5	4.0
	-8.5	-9.1	12.9	5.3	12.1	4.9	11.2	4.6	10.8	4.4	10.3	4.2	9.5	3.9
	-7.0	-7.6	12.9	5.1	12.1	4.7	11.2	4.4	10.8	4.2	10.3	4.1	9.5	3.7
	-5.0	-5.6	12.9	4.8	12.1	4.5	11.2	4.2	10.8	4.0	10.3	3.9	9.5	3.5
	-3.0	-3.7	12.9	4.6	12.1	4.3	11.2	4.0	10.8	3.8	10.3	3.7	9.5	3.4
	0.0	-0.7	12.9	4.3	12.1	4.0	11.2	3.7	10.8	3.5	10.3	3.4	9.5	3.1
	3.0	2.2	12.9	3.9	12.1	3.7	11.2	3.4	10.8	3.3	10.3	3.1	9.5	2.9
	5.0	4.1	12.9	3.7	12.1	3.5	11.2	3.2	10.8	3.1	10.3	3.0	9.5	2.7
	7.0	6.0	12.9	3.5	12.1	3.3	11.2	3.0	10.8	2.9	10.3	2.8	9.5	2.6
9.0	7.9	12.9	3.3	12.1	3.1	11.2	2.9	10.8	2.8	10.3	2.7	9.5	2.4	
11.0	9.8	12.9	3.2	12.1	2.9	11.2	2.7	10.8	2.6	10.3	2.5	9.5	2.3	
13.0	11.8	12.9	3.0	12.1	2.8	11.2	2.6	10.8	2.5	10.3	2.3	9.5	2.1	
15.0	13.7	12.9	2.8	12.1	2.6	11.2	2.4	10.8	2.3	10.3	2.2	9.5	2.0	
60%	-19.8	-20.0	10.0	5.1	10.0	5.2	9.6	5.0	9.2	4.8	8.9	4.6	8.1	4.3
	-18.8	-19.0	10.3	5.2	10.3	5.3	9.6	4.9	9.2	4.7	8.9	4.5	8.1	4.2
	-16.7	-17.0	11.1	5.4	10.3	5.0	9.6	4.7	9.2	4.5	8.9	4.3	8.1	4.0
	-13.7	-15.0	11.1	5.1	10.3	4.8	9.6	4.5	9.2	4.3	8.9	4.1	8.1	3.8
	-11.8	-13.0	11.1	4.9	10.3	4.6	9.6	4.3	9.2	4.1	8.9	3.9	8.1	3.6
	-9.8	-11.0	11.1	4.7	10.3	4.4	9.6	4.0	9.2	3.9	8.9	3.8	8.1	3.5
	-9.5	-10.0	11.1	4.5	10.3	4.2	9.6	4.0	9.2	3.8	8.9	3.7	8.1	3.4
	-8.5	-9.1	11.1	4.4	10.3	4.2	9.6	3.9	9.2	3.7	8.9	3.6	8.1	3.3
	-7.0	-7.6	11.1	4.3	10.3	4.0	9.6	3.7	9.2	3.6	8.9	3.4	8.1	3.2
	-5.0	-5.6	11.1	4.1	10.3	3.8	9.6	3.5	9.2	3.4	8.9	3.3	8.1	3.0
	-3.0	-3.7	11.1	3.9	10.3	3.6	9.6	3.4	9.2	3.2	8.9	3.1	8.1	2.9
	0.0	-0.7	11.1	3.6	10.3	3.3	9.6	3.1	9.2	3.0	8.9	2.9	8.1	2.6
	3.0	2.2	11.1	3.3	10.3	3.1	9.6	2.9	9.2	2.8	8.9	2.6	8.1	2.4
	5.0	4.1	11.1	3.1	10.3	2.9	9.6	2.7	9.2	2.6	8.9	2.5	8.1	2.3
	7.0	6.0	11.1	2.9	10.3	2.8	9.6	2.6	9.2	2.5	8.9	2.4	8.1	2.2
9.0	7.9	11.1	2.8	10.3	2.6	9.6	2.4	9.2	2.3	8.9	2.2	8.1	2.0	
11.0	9.8	11.1	2.6	10.3	2.4	9.6	2.3	9.2	2.2	8.9	2.1	8.1	1.9	
13.0	11.8	11.1	2.5	10.3	2.3	9.6	2.1	9.2	2.1	8.9	2.0	8.1	1.8	
15.0	13.7	11.1	2.3	10.3	2.2	9.6	2.0	9.2	1.9	8.9	1.8	8.1	1.7	
50%	-19.8	-20.0	9.2	4.8	8.6	4.5	8.0	4.2	7.7	4.0	7.4	3.9	6.8	3.6
	-18.8	-19.0	9.2	4.7	8.6	4.4	8.0	4.1	7.7	3.9	7.4	3.8	6.8	3.5
	-16.7	-17.0	9.2	4.4	8.6	4.2	8.0	3.9	7.7	3.8	7.4	3.6	6.8	3.4
	-13.7	-15.0	9.2	4.2	8.6	4.0	8.0	3.7	7.7	3.6	7.4	3.4	6.8	3.2
	-11.8	-13.0	9.2	4.0	8.6	3.8	8.0	3.5	7.7	3.4	7.4	3.3	6.8	3.0
	-9.8	-11.0	9.2	3.8	8.6	3.6	8.0	3.3	7.7	3.2	7.4	3.1	6.8	2.9
	-9.5	-10.0	9.2	3.7	8.6	3.5	8.0	3.3	7.7	3.2	7.4	3.0	6.8	2.8
	-8.5	-9.1	9.2	3.6	8.6	3.4	8.0	3.2	7.7	3.1	7.4	3.0	6.8	2.7
	-7.0	-7.6	9.2	3.5	8.6	3.3	8.0	3.1	7.7	3.0	7.4	2.9	6.8	2.6
	-5.0	-5.6	9.2	3.3	8.6	3.1	8.0	2.9	7.7	2.8	7.4	2.7	6.8	2.5
	-3.0	-3.7	9.2	3.2	8.6	3.0	8.0	2.8	7.7	2.7	7.4	2.6	6.8	2.4
	0.0	-0.7	9.2	2.9	8.6	2.7	8.0	2.6	7.7	2.5	7.4	2.4	6.8	2.2
	3.0	2.2	9.2	2.7	8.6	2.5	8.0	2.4	7.7	2.3	7.4	2.2	6.8	2.0
	5.0	4.1	9.2	2.5	8.6	2.4	8.0	2.2	7.7	2.1	7.4	2.1	6.8	1.9
	7.0	6.0	9.2	2.4	8.6	2.2	8.0	2.1	7.7	2.0	7.4	1.9	6.8	1.8
9.0	7.9	9.2	2.3	8.6	2.1	8.0	2.0	7.7	1.9	7.4	1.8	6.8	1.7	
11.0	9.8	9.2	2.1	8.6	2.0	8.0	1.9	7.7	1.8	7.4	1.7	6.8	1.6	
13.0	11.8	9.2	2.0	8.6	1.9	8.0	1.8	7.7	1.7	7.4	1.7	6.8	1.5	
15.0	13.7	9.2	1.9	8.6	1.7	8.0	1.6	7.7	1.6	7.4	1.5	6.8	1.4	

Abbreviations:

CR: Combination ratio

TC: Total capacity (kW)

PI: Power input (compressor + outdoor fan motor) (kW)

Notes:

Shaded cells indicate rating condition.

Table2-8.13:160 model heating capacity - 380-415V 3N~50Hz

CR	Outdoor air temp.		Indoor air temp. °C DB											
			16.0		18.0		20.0		21.0		22.0		24.0	
	°C DB	°C WB	TC kW	PI kW	TC kW	PI kW	TC kW	PI kW	TC kW	PI kW	TC kW	PI kW	TC kW	PI kW
130%	-19.8	-20.0	11.2	4.7	11.1	4.8	11.0	4.9	10.9	5.0	10.8	5.0	10.8	5.1
	-18.8	-19.0	11.6	4.8	11.4	4.9	11.3	5.0	11.3	5.0	11.2	5.1	11.1	5.2
	-16.7	-17.0	12.3	4.9	12.2	5.0	12.0	5.1	12.0	5.1	11.9	5.2	11.8	5.3
	-13.7	-15.0	13.0	5.0	12.9	5.1	12.8	5.2	12.7	5.3	12.7	5.3	12.6	5.5
	-11.8	-13.0	13.8	5.1	13.7	5.2	13.5	5.3	13.5	5.4	13.4	5.5	13.3	5.6
	-9.8	-11.0	14.5	5.2	14.4	5.3	14.3	5.5	14.2	5.5	14.2	5.6	14.0	5.7
	-9.5	-10.0	14.9	5.3	14.8	5.4	14.7	5.5	14.6	5.6	14.5	5.7	14.4	5.8
	-8.5	-9.1	15.3	5.3	15.1	5.4	15.0	5.6	14.9	5.7	14.9	5.7	14.8	5.9
	-7.0	-7.6	15.8	5.4	15.7	5.5	15.6	5.7	15.5	5.8	15.4	5.8	15.3	6.0
	-5.0	-5.6	16.6	5.5	16.5	5.7	16.4	5.8	16.3	5.9	16.2	6.0	16.1	6.2
	-3.0	-3.7	17.4	5.6	17.3	5.8	17.1	6.0	17.0	6.1	17.0	6.1	16.8	6.3
	0.0	-0.7	18.6	5.9	18.5	6.0	18.3	6.2	18.3	6.3	18.2	6.4	18.1	6.6
	3.0	2.2	19.9	6.1	19.7	6.3	19.5	6.4	19.5	6.5	19.4	6.6	19.3	6.7
	5.0	4.1	20.7	6.2	20.5	6.4	20.4	6.6	20.3	6.7	20.2	6.8	19.3	6.3
	7.0	6.0	21.5	6.4	21.4	6.6	21.2	6.8	21.1	6.9	21.0	6.8	19.3	6.1
9.0	7.9	22.4	6.5	22.2	6.7	22.0	6.9	21.9	6.9	21.0	6.4	19.3	5.8	
11.0	9.8	23.2	6.7	23.1	6.9	22.8	6.9	21.9	6.5	21.0	6.1	19.3	5.5	
13.0	11.8	24.2	6.9	24.0	7.1	22.8	6.5	21.9	6.1	21.0	5.8	19.3	5.2	
15.0	13.7	25.1	7.0	24.5	6.8	22.8	6.1	21.9	5.8	21.0	5.5	19.3	4.9	
120%	-19.8	-20.0	11.1	4.8	11.0	4.9	10.8	4.9	10.8	5.0	10.7	5.1	10.7	5.2
	-18.8	-19.0	11.4	4.8	11.3	4.9	11.2	5.0	11.1	5.1	11.1	5.1	11.0	5.2
	-16.7	-17.0	12.2	4.9	12.0	5.0	11.9	5.1	11.9	5.2	11.8	5.2	11.7	5.4
	-13.7	-15.0	12.9	5.0	12.8	5.1	12.7	5.3	12.6	5.3	12.6	5.4	12.5	5.5
	-11.8	-13.0	13.6	5.1	13.5	5.3	13.4	5.4	13.3	5.5	13.3	5.5	13.2	5.7
	-9.8	-11.0	14.4	5.3	14.3	5.4	14.1	5.5	14.1	5.6	14.0	5.7	13.9	5.8
	-9.5	-10.0	14.8	5.3	14.6	5.5	14.5	5.6	14.4	5.7	14.4	5.7	14.3	5.9
	-8.5	-9.1	15.1	5.4	15.0	5.5	14.8	5.7	14.8	5.7	14.7	5.8	14.6	6.0
	-7.0	-7.6	15.7	5.5	15.5	5.6	15.4	5.8	15.4	5.9	15.3	5.9	15.2	6.1
	-5.0	-5.6	16.5	5.6	16.3	5.8	16.2	5.9	16.1	6.0	16.1	6.1	16.0	6.3
	-3.0	-3.7	17.2	5.7	17.1	5.9	16.9	6.1	16.9	6.2	16.8	6.3	16.7	6.4
	0.0	-0.7	18.4	6.0	18.3	6.1	18.2	6.3	18.1	6.4	18.0	6.5	17.8	6.5
	3.0	2.2	19.7	6.2	19.5	6.4	19.4	6.6	19.3	6.7	19.4	6.8	17.8	6.0
	5.0	4.1	20.5	6.4	20.3	6.6	20.2	6.8	20.2	6.8	19.4	6.4	17.8	5.7
	7.0	6.0	21.3	6.5	21.1	6.7	21.0	6.8	20.2	6.4	19.4	6.1	17.8	5.5
9.0	7.9	22.1	6.7	22.0	6.9	21.0	6.4	20.2	6.1	19.4	5.8	17.8	5.2	
11.0	9.8	23.0	6.9	22.6	6.8	21.0	6.1	20.2	5.8	19.4	5.5	17.8	4.9	
13.0	11.8	24.2	7.1	22.6	6.4	21.0	5.8	20.2	5.5	19.4	5.2	17.8	4.6	
15.0	13.7	24.2	6.7	22.6	6.1	21.0	5.5	20.2	5.2	19.4	4.9	17.8	4.4	
110%	-19.8	-20.0	11.0	4.8	10.8	4.9	10.7	5.0	10.7	5.0	10.7	5.1	10.6	5.2
	-18.8	-19.0	11.3	4.9	11.2	5.0	11.1	5.1	11.1	5.1	11.0	5.2	10.9	5.3
	-16.7	-17.0	12.0	5.0	11.9	5.1	11.8	5.2	11.8	5.2	11.7	5.3	11.6	5.4
	-13.7	-15.0	12.8	5.1	12.6	5.2	12.5	5.3	12.5	5.4	12.4	5.5	12.3	5.6
	-11.8	-13.0	13.5	5.2	13.4	5.3	13.2	5.5	13.2	5.5	13.1	5.6	13.1	5.8
	-9.8	-11.0	14.2	5.3	14.1	5.5	14.0	5.6	13.9	5.7	13.9	5.8	13.8	5.9
	-9.5	-10.0	14.6	5.4	14.5	5.5	14.4	5.7	14.3	5.8	14.2	5.8	14.1	6.0
	-8.5	-9.1	14.9	5.5	14.8	5.6	14.7	5.8	14.6	5.8	14.6	5.9	14.5	6.1
	-7.0	-7.6	15.5	5.6	15.4	5.7	15.3	5.9	15.2	6.0	15.1	6.0	15.0	6.2
	-5.0	-5.6	16.3	5.7	16.2	5.9	16.0	6.0	16.0	6.1	15.9	6.2	15.8	6.4
	-3.0	-3.7	17.0	5.9	16.9	6.0	16.8	6.2	16.7	6.3	16.6	6.4	16.3	6.3
	0.0	-0.7	18.3	6.1	18.1	6.3	18.0	6.5	17.9	6.6	17.8	6.5	16.3	5.8
	3.0	2.2	19.5	6.4	19.3	6.6	19.3	6.7	18.5	6.3	17.8	6.0	16.3	5.4
	5.0	4.1	20.3	6.5	20.1	6.7	19.3	6.3	18.5	6.0	17.8	5.7	16.3	5.2
	7.0	6.0	21.1	6.7	20.7	6.6	19.3	6.0	18.5	5.7	17.8	5.4	16.3	4.9
9.0	7.9	22.2	6.9	20.7	6.3	19.3	5.7	18.5	5.4	17.8	5.2	16.3	4.6	
11.0	9.8	22.2	6.5	20.7	6.0	19.3	5.4	18.5	5.2	17.8	4.9	16.3	4.4	
13.0	11.8	22.2	6.2	20.7	5.6	19.3	5.1	18.5	4.9	17.8	4.6	16.3	4.1	
15.0	13.7	22.2	5.9	20.7	5.3	19.3	4.8	18.5	4.6	17.8	4.3	16.3	3.9	

Abbreviations:

CR: Combination ratio

TC: Total capacity (kW)

PI: Power input (compressor + outdoor fan motor) (kW)

Notes:

Shaded cells indicate rating condition.

Table continued on next page ...

Table2-8.13:160 model heating capacity - 380-415V 3N~50Hz (continued)

CR	Outdoor air temp.		Indoor air temp. °C DB											
			16.0		18.0		20.0		21.0		22.0		24.0	
	°C DB	°C WB	TC	PI	TC	PI	TC	PI	TC	PI	TC	PI	TC	PI
100%	-19.8	-20.0	10.8	4.9	10.7	5.0	10.6	5.1	10.6	5.1	10.6	5.2	10.5	5.3
	-18.8	-19.0	11.2	4.9	11.1	5.0	11.0	5.1	10.9	5.2	10.9	5.2	10.8	5.4
	-16.7	-17.0	11.9	5.0	11.8	5.1	11.7	5.3	11.6	5.3	11.6	5.4	11.5	5.5
	-13.7	-15.0	12.6	5.2	12.5	5.3	12.4	5.4	12.3	5.5	12.3	5.5	12.2	5.7
	-11.8	-13.0	13.3	5.3	13.2	5.4	13.1	5.6	13.1	5.6	13.0	5.7	12.9	5.9
	-9.8	-11.0	14.1	5.4	13.9	5.6	13.8	5.7	13.8	5.8	13.7	5.9	13.7	6.0
	-9.5	-10.0	14.4	5.5	14.3	5.7	14.2	5.8	14.2	5.9	14.1	6.0	14.0	6.1
	-8.5	-9.1	14.8	5.6	14.6	5.7	14.5	5.9	14.5	6.0	14.4	6.0	14.3	6.2
	-7.0	-7.6	15.3	5.7	15.2	5.8	15.1	6.0	15.0	6.1	15.0	6.2	14.8	6.2
	-5.0	-5.6	16.1	5.9	16.0	6.0	15.9	6.2	15.8	6.3	15.7	6.4	14.8	5.9
	-3.0	-3.7	16.8	6.0	16.7	6.2	16.6	6.4	16.8	6.6	16.2	6.2	14.8	5.6
	0.0	-0.7	18.0	6.3	17.9	6.5	17.5	6.3	16.8	6.0	16.2	5.7	14.8	5.2
	3.0	2.2	19.2	6.6	18.8	6.4	17.5	5.9	16.8	5.6	16.2	5.3	14.8	4.8
	5.0	4.1	20.2	6.7	18.8	6.1	17.5	5.6	16.8	5.3	16.2	5.1	14.8	4.6
	7.0	6.0	20.2	6.3	18.8	5.8	17.5	5.3	16.8	5.1	16.2	4.8	14.8	4.3
9.0	7.9	20.2	6.0	18.8	5.5	17.5	5.0	16.8	4.8	16.2	4.6	14.8	4.1	
11.0	9.8	20.2	5.7	18.8	5.2	17.5	4.8	16.8	4.5	16.2	4.3	14.8	3.9	
13.0	11.8	20.2	5.4	18.8	4.9	17.5	4.5	16.8	4.3	16.2	4.0	14.8	3.7	
15.0	13.7	20.2	5.1	18.8	4.7	17.5	4.2	16.8	4.0	16.2	3.8	14.8	3.4	
90%	-19.8	-20.0	10.7	4.9	10.6	5.0	10.5	5.1	10.5	5.2	10.5	5.2	10.4	5.4
	-18.8	-19.0	11.1	5.0	11.0	5.1	10.9	5.2	10.8	5.3	10.8	5.3	10.7	5.5
	-16.7	-17.0	11.7	5.1	11.6	5.2	11.6	5.4	11.5	5.4	11.5	5.5	11.4	5.6
	-13.7	-15.0	12.5	5.3	12.4	5.4	12.3	5.5	12.2	5.6	12.2	5.7	12.1	5.8
	-11.8	-13.0	13.2	5.4	13.1	5.5	13.0	5.7	12.9	5.8	12.9	5.8	12.8	6.0
	-9.8	-11.0	13.9	5.6	13.8	5.7	13.7	5.9	13.6	5.9	13.6	6.0	13.3	5.9
	-9.5	-10.0	14.3	5.6	14.2	5.8	14.0	5.9	14.0	6.0	14.0	6.1	13.3	5.8
	-8.5	-9.1	14.6	5.7	14.5	5.9	14.4	6.0	14.3	6.1	14.5	6.3	13.3	5.6
	-7.0	-7.6	15.2	5.8	15.0	6.0	14.9	6.2	15.1	6.4	14.5	6.0	13.3	5.5
	-5.0	-5.6	15.9	6.0	15.8	6.2	15.8	6.3	15.1	6.0	14.5	5.7	13.3	5.2
	-3.0	-3.7	16.6	6.2	16.5	6.4	15.8	6.0	15.1	5.7	14.5	5.5	13.3	5.0
	0.0	-0.7	18.2	6.6	17.0	6.0	15.8	5.5	15.1	5.3	14.5	5.1	13.3	4.6
	3.0	2.2	18.2	6.1	17.0	5.6	15.8	5.1	15.1	4.9	14.5	4.7	13.3	4.3
	5.0	4.1	18.2	5.8	17.0	5.3	15.8	4.9	15.1	4.7	14.5	4.4	13.3	4.0
	7.0	6.0	18.2	5.5	17.0	5.1	15.8	4.6	15.1	4.4	14.5	4.2	13.3	3.8
9.0	7.9	18.2	5.2	17.0	4.8	15.8	4.4	15.1	4.2	14.5	4.0	13.3	3.6	
11.0	9.8	18.2	4.9	17.0	4.5	15.8	4.1	15.1	4.0	14.5	3.8	13.3	3.4	
13.0	11.8	18.2	4.7	17.0	4.3	15.8	3.9	15.1	3.7	14.5	3.6	13.3	3.2	
15.0	13.7	18.2	4.4	17.0	4.0	15.8	3.7	15.1	3.5	14.5	3.3	13.3	3.0	
80%	-19.8	-20.0	10.6	5.0	10.5	5.1	10.4	5.2	10.4	5.3	10.4	5.4	10.3	5.5
	-18.8	-19.0	10.9	5.1	10.8	5.2	10.8	5.3	10.7	5.4	10.7	5.4	10.7	5.6
	-16.7	-17.0	11.6	5.2	11.5	5.3	11.4	5.5	11.4	5.5	11.4	5.6	11.3	5.8
	-13.7	-15.0	12.3	5.4	12.2	5.5	12.1	5.7	12.1	5.7	12.1	5.8	11.8	5.7
	-11.8	-13.0	13.0	5.5	12.9	5.7	12.8	5.8	12.8	5.9	12.9	6.0	11.8	5.4
	-9.8	-11.0	13.7	5.7	13.6	5.9	13.5	6.0	13.5	6.0	12.9	5.7	11.8	5.2
	-9.5	-10.0	14.1	5.8	14.0	6.0	14.0	6.1	13.5	5.8	12.9	5.5	11.8	5.1
	-8.5	-9.1	14.4	5.9	14.3	6.1	14.0	6.0	13.5	5.7	12.9	5.4	11.8	5.0
	-7.0	-7.6	15.0	6.0	15.1	6.3	14.0	5.7	13.5	5.5	12.9	5.2	11.8	4.8
	-5.0	-5.6	15.7	6.2	15.1	5.9	14.0	5.4	13.5	5.2	12.9	5.0	11.8	4.6
	-3.0	-3.7	16.2	6.1	15.1	5.6	14.0	5.2	13.5	5.0	12.9	4.8	11.8	4.3
	0.0	-0.7	16.2	5.6	15.1	5.2	14.0	4.8	13.5	4.6	12.9	4.4	11.8	4.0
	3.0	2.2	16.2	5.2	15.1	4.8	14.0	4.5	13.5	4.3	12.9	4.1	11.8	3.7
	5.0	4.1	16.2	5.0	15.1	4.6	14.0	4.2	13.5	4.0	12.9	3.9	11.8	3.5
	7.0	6.0	16.2	4.7	15.1	4.3	14.0	4.0	13.5	3.8	12.9	3.7	11.8	3.3
9.0	7.9	16.2	4.5	15.1	4.1	14.0	3.8	13.5	3.6	12.9	3.5	11.8	3.2	
11.0	9.8	16.2	4.2	15.1	3.9	14.0	3.6	13.5	3.4	12.9	3.3	11.8	3.0	
13.0	11.8	16.2	3.9	15.1	3.7	14.0	3.4	13.5	3.2	12.9	3.1	11.8	2.8	
15.0	13.7	16.2	3.7	15.1	3.4	14.0	3.2	13.5	3.0	12.9	2.9	11.8	2.6	

Abbreviations:
 CR: Combination ratio
 TC: Total capacity (kW)
 PI: Power input (compressor + outdoor fan motor) (kW)
 Notes:
 Shaded cells indicate rating condition.

Table continued on next page ...

Table2-8.13:160 model heating capacity - 380-415V 3N~50Hz (continued)

CR	Outdoor air temp.		Indoor air temp. °C DB											
			16.0		18.0		20.0		21.0		22.0		24.0	
	°C DB	°C WB	TC	PI	TC	PI	TC	PI	TC	PI	TC	PI	TC	PI
70%	-19.8	-20.0	10.4	5.1	10.4	5.2	10.3	5.4	10.3	5.4	10.3	5.5	10.4	5.6
	-18.8	-19.0	10.8	5.2	10.7	5.3	10.6	5.5	10.6	5.5	10.6	5.6	10.4	5.4
	-16.7	-17.0	11.4	5.4	11.4	5.5	11.3	5.6	11.3	5.7	11.3	5.7	10.4	5.2
	-13.7	-15.0	12.1	5.5	12.1	5.7	12.3	6.0	11.8	5.6	11.3	5.4	10.4	4.9
	-11.8	-13.0	12.8	5.7	12.8	5.9	12.3	5.6	11.8	5.4	11.3	5.1	10.4	4.7
	-9.8	-11.0	13.5	5.9	13.2	5.8	12.3	5.3	11.8	5.1	11.3	4.9	10.4	4.5
	-9.5	-10.0	14.1	6.1	13.2	5.6	12.3	5.2	11.8	5.0	11.3	4.8	10.4	4.4
	-8.5	-9.1	14.1	6.0	13.2	5.5	12.3	5.1	11.8	4.9	11.3	4.7	10.4	4.3
	-7.0	-7.6	14.1	5.7	13.2	5.3	12.3	4.9	11.8	4.7	11.3	4.5	10.4	4.1
	-5.0	-5.6	14.1	5.4	13.2	5.1	12.3	4.7	11.8	4.5	11.3	4.3	10.4	3.9
	-3.0	-3.7	14.1	5.2	13.2	4.8	12.3	4.5	11.8	4.3	11.3	4.1	10.4	3.7
	0.0	-0.7	14.1	4.8	13.2	4.4	12.3	4.1	11.8	3.9	11.3	3.8	10.4	3.5
	3.0	2.2	14.1	4.4	13.2	4.1	12.3	3.8	11.8	3.6	11.3	3.5	10.4	3.2
	5.0	4.1	14.1	4.2	13.2	3.9	12.3	3.6	11.8	3.5	11.3	3.3	10.4	3.0
	7.0	6.0	14.1	4.0	13.2	3.7	12.3	3.4	11.8	3.3	11.3	3.1	10.4	2.9
9.0	7.9	14.1	3.8	13.2	3.5	12.3	3.2	11.8	3.1	11.3	3.0	10.4	2.7	
11.0	9.8	14.1	3.6	13.2	3.3	12.3	3.0	11.8	2.9	11.3	2.8	10.4	2.6	
13.0	11.8	14.1	3.3	13.2	3.1	12.3	2.9	11.8	2.7	11.3	2.6	10.4	2.4	
15.0	13.7	14.1	3.1	13.2	2.9	12.3	2.7	11.8	2.6	11.3	2.5	10.4	2.3	
60%	-19.8	-20.0	10.3	5.3	10.3	5.4	10.2	5.6	10.1	5.3	9.7	5.1	8.9	4.7
	-18.8	-19.0	10.6	5.4	10.6	5.5	10.5	5.5	10.1	5.2	9.7	5.0	8.9	4.6
	-16.7	-17.0	11.3	5.6	11.3	5.7	10.5	5.2	10.1	5.0	9.7	4.8	8.9	4.4
	-13.7	-15.0	12.1	5.8	11.3	5.3	10.5	5.0	10.1	4.8	9.7	4.6	8.9	4.2
	-11.8	-13.0	12.1	5.5	11.3	5.1	10.5	4.7	10.1	4.6	9.7	4.4	8.9	4.0
	-9.8	-11.0	12.1	5.2	11.3	4.9	10.5	4.5	10.1	4.3	9.7	4.2	8.9	3.8
	-9.5	-10.0	12.1	5.1	11.3	4.7	10.5	4.4	10.1	4.2	9.7	4.1	8.9	3.7
	-8.5	-9.1	12.1	5.0	11.3	4.6	10.5	4.3	10.1	4.1	9.7	4.0	8.9	3.7
	-7.0	-7.6	12.1	4.8	11.3	4.5	10.5	4.1	10.1	4.0	9.7	3.8	8.9	3.5
	-5.0	-5.6	12.1	4.6	11.3	4.2	10.5	3.9	10.1	3.8	9.7	3.6	8.9	3.3
	-3.0	-3.7	12.1	4.3	11.3	4.0	10.5	3.7	10.1	3.6	9.7	3.5	8.9	3.2
	0.0	-0.7	12.1	4.0	11.3	3.7	10.5	3.5	10.1	3.3	9.7	3.2	8.9	2.9
	3.0	2.2	12.1	3.7	11.3	3.4	10.5	3.2	10.1	3.1	9.7	3.0	8.9	2.7
	5.0	4.1	12.1	3.5	11.3	3.3	10.5	3.0	10.1	2.9	9.7	2.8	8.9	2.6
	7.0	6.0	12.1	3.3	11.3	3.1	10.5	2.9	10.1	2.8	9.7	2.6	8.9	2.4
9.0	7.9	12.1	3.1	11.3	2.9	10.5	2.7	10.1	2.6	9.7	2.5	8.9	2.3	
11.0	9.8	12.1	2.9	11.3	2.7	10.5	2.6	10.1	2.5	9.7	2.4	8.9	2.2	
13.0	11.8	12.1	2.8	11.3	2.6	10.5	2.4	10.1	2.3	9.7	2.2	8.9	2.0	
15.0	13.7	12.1	2.6	11.3	2.4	10.5	2.3	10.1	2.2	9.7	2.1	8.9	1.9	
50%	-19.8	-20.0	10.1	5.3	9.4	5.0	8.8	4.6	8.4	4.5	8.1	4.3	7.4	4.0
	-18.8	-19.0	10.1	5.2	9.4	4.8	8.8	4.5	8.4	4.4	8.1	4.2	7.4	3.9
	-16.7	-17.0	10.1	4.9	9.4	4.6	8.8	4.3	8.4	4.2	8.1	4.0	7.4	3.7
	-13.7	-15.0	10.1	4.7	9.4	4.4	8.8	4.1	8.4	4.0	8.1	3.8	7.4	3.5
	-11.8	-13.0	10.1	4.5	9.4	4.2	8.8	3.9	8.4	3.8	8.1	3.6	7.4	3.4
	-9.8	-11.0	10.1	4.3	9.4	4.0	8.8	3.7	8.4	3.6	8.1	3.5	7.4	3.2
	-9.5	-10.0	10.1	4.2	9.4	3.9	8.8	3.6	8.4	3.5	8.1	3.4	7.4	3.1
	-8.5	-9.1	10.1	4.1	9.4	3.8	8.8	3.5	8.4	3.4	8.1	3.3	7.4	3.0
	-7.0	-7.6	10.1	3.9	9.4	3.7	8.8	3.4	8.4	3.3	8.1	3.2	7.4	2.9
	-5.0	-5.6	10.1	3.7	9.4	3.5	8.8	3.2	8.4	3.1	8.1	3.0	7.4	2.8
	-3.0	-3.7	10.1	3.5	9.4	3.3	8.8	3.1	8.4	3.0	8.1	2.9	7.4	2.6
	0.0	-0.7	10.1	3.3	9.4	3.0	8.8	2.8	8.4	2.7	8.1	2.6	7.4	2.4
	3.0	2.2	10.1	3.0	9.4	2.8	8.8	2.6	8.4	2.5	8.1	2.4	7.4	2.2
	5.0	4.1	10.1	2.8	9.4	2.7	8.8	2.5	8.4	2.4	8.1	2.3	7.4	2.1
	7.0	6.0	10.1	2.7	9.4	2.5	8.8	2.3	8.4	2.3	8.1	2.2	7.4	2.0
9.0	7.9	10.1	2.5	9.4	2.4	8.8	2.2	8.4	2.1	8.1	2.0	7.4	1.9	
11.0	9.8	10.1	2.4	9.4	2.2	8.8	2.1	8.4	2.0	8.1	1.9	7.4	1.8	
13.0	11.8	10.1	2.2	9.4	2.1	8.8	1.9	8.4	1.9	8.1	1.8	7.4	1.7	
15.0	13.7	10.1	2.1	9.4	2.0	8.8	1.8	8.4	1.8	8.1	1.7	7.4	1.6	

Abbreviations:

CR: Combination ratio

TC: Total capacity (kW)

PI: Power input (compressor + outdoor fan motor) (kW)

Notes:

Shaded cells indicate rating condition.

8.3 Capacity Correction Factors for Piping Length and Level Difference- 220-240V~50Hz

Figure 2-8.1: 80 model rate of change in cooling capacity

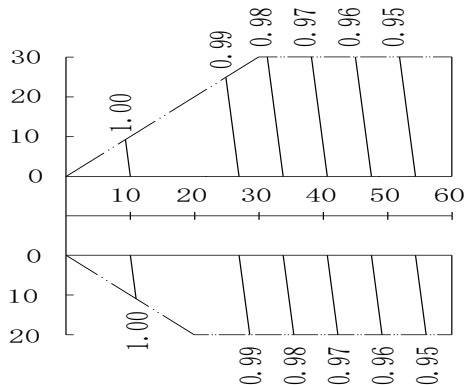

Figure 2-8.2: 80 model rate of change in heating capacity

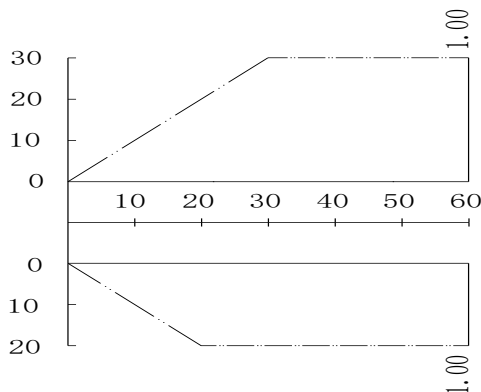

Figure 2-8.3: 100 model rate of change in cooling capacity

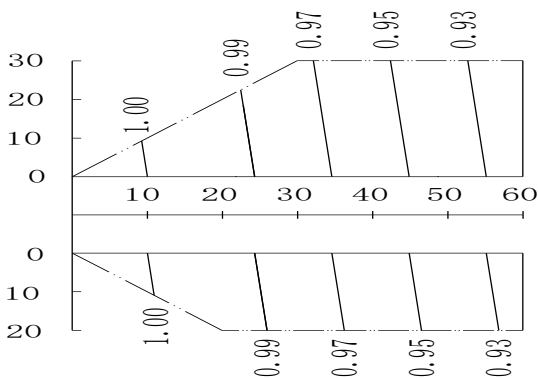

Figure 2-8.4: 100 model rate of change in heating capacity

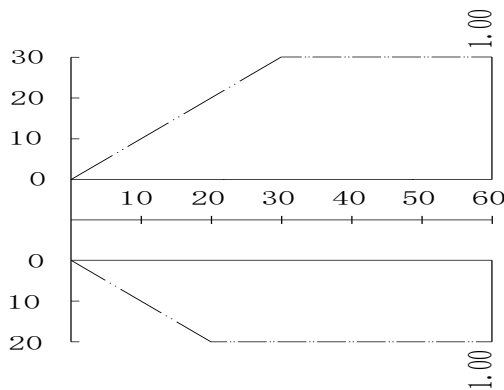

Figure 2-8.5: 120 model rate of change in cooling capacity

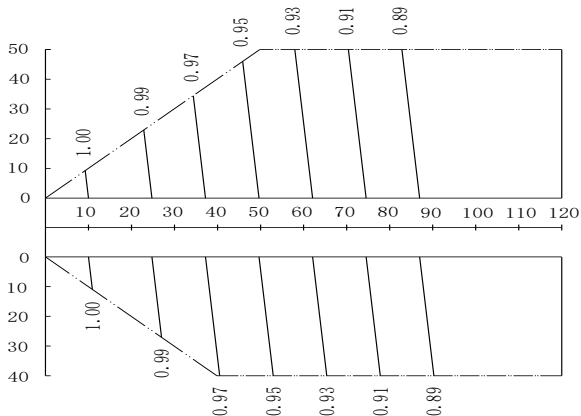

Figure 2-8.6: 120 model rate of change in heating capacity

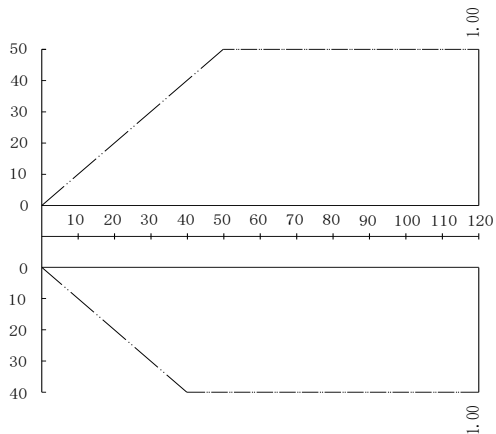

Figure 2-8.7: 140 model rate of change in cooling capacity

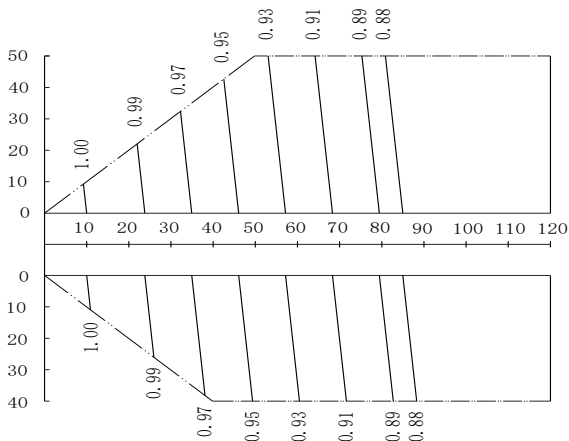

Figure 2-8.8: 140 model rate of change in heating capacity

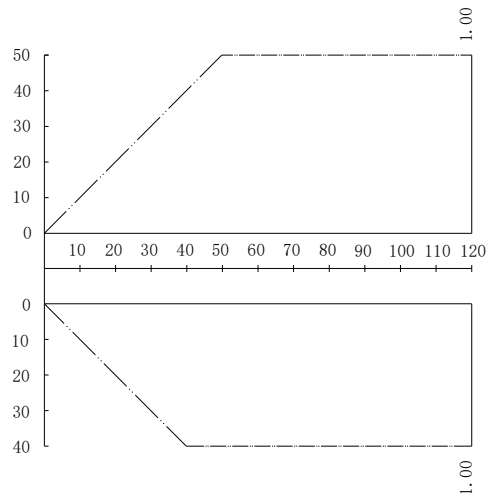

Figure 2-8.9: 160 model rate of change in cooling capacity

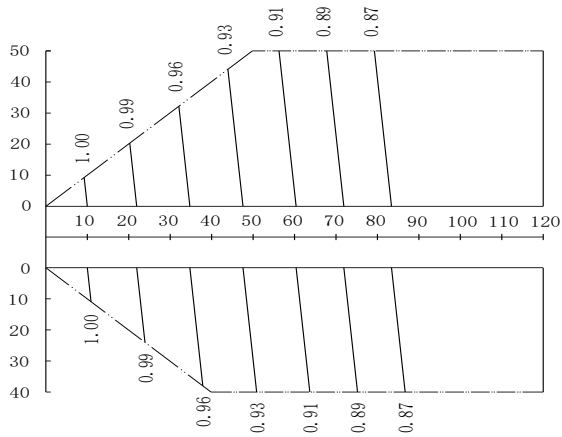
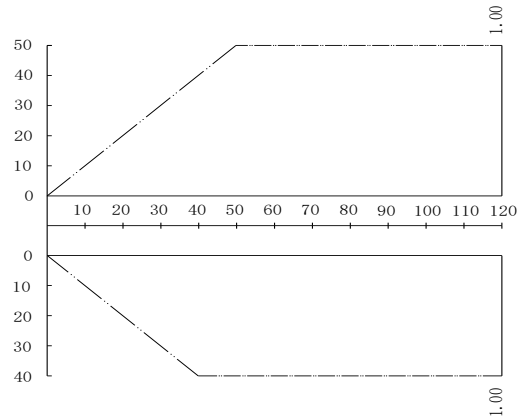

Figure 2-8.10: 160 model rate of change in heating capacity



Capacity Correction Factors for Piping Length and Level Difference- 380-415V 3N~50Hz

Figure 2-8.11: 120 model rate of change in cooling capacity

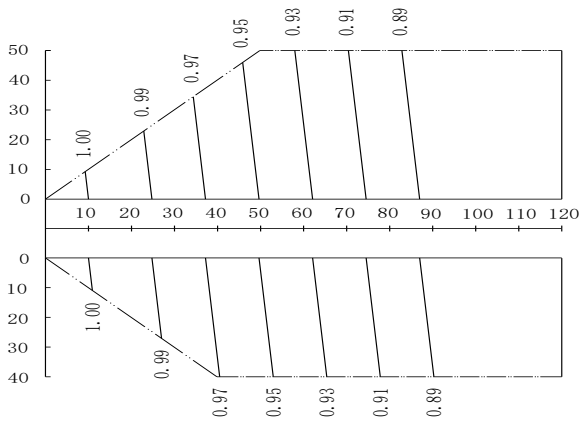

Figure 2-8.12: 120 model rate of change in heating capacity

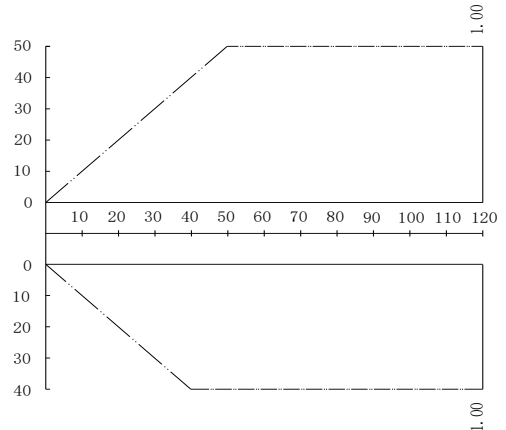

Figure 2-8.13: 140 model rate of change in cooling capacity

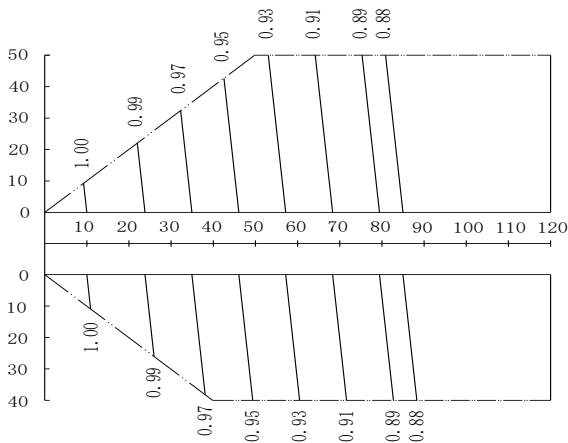

Figure 2-8.14: 140 model rate of change in heating capacity

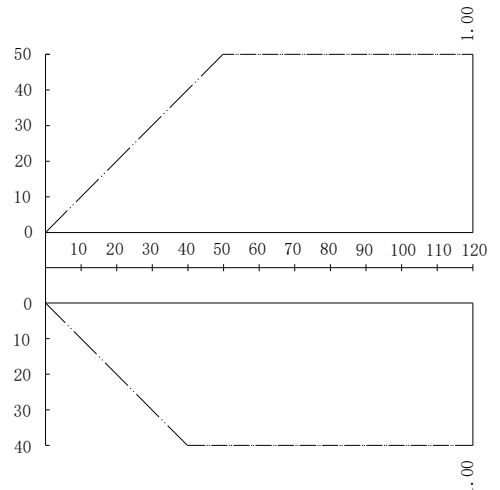

Figure 2-8.15: 160 model rate of change in cooling capacity

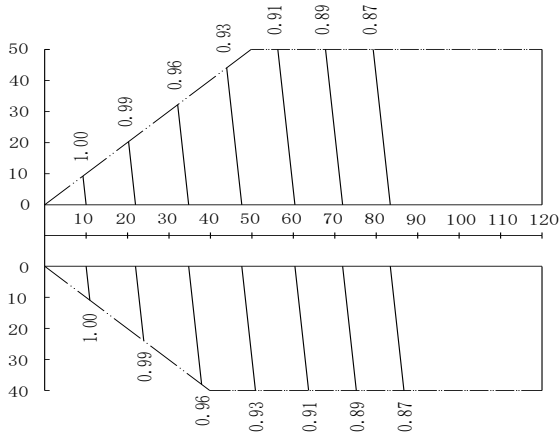
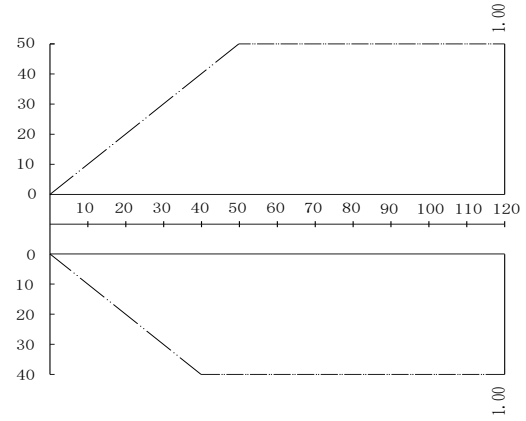

Figure 2-8.16: 160 model rate of change in heating capacity



Notes:

1. The horizontal axis shows equivalent length of piping between farthest indoor unit and first outdoor branch joint; the vertical axis shows the largest level difference between indoor unit and outdoor unit. For level differences, positive values indicate that the outdoor unit is above the indoor unit, negative values indicate that the outdoor unit is below the indoor unit.
2. These figures illustrate the rate of change in capacity of a system with only standard indoor units at maximum load (with the thermostat set to maximum) under standard conditions. Under partial load conditions there is only a minor deviation from the rate of change in capacity shown in these figures.
3. The capacity of the system is either the total capacity of the indoor units obtained from indoor unit capacity tables or the corrected capacity of the outdoor units as per the calculations below, whichever is smaller.

Corrected capacity of outdoor units	=	Capacity of outdoor units obtained from outdoor unit capacity tables at the combination ratio	x	Capacity correction factor
-------------------------------------	---	---	---	----------------------------

8.4 Capacity Correction Factors for Frost Accumulation

The heating capacity tables do not take account of the reduction in capacity when frost has accumulated or while the defrosting operation is in progress. If snow has accumulated against the outside surface of the outdoor unit heat exchanger heating capacity is reduced. The reduction in heating capacity is dependent on a number of factors including the outdoor temperature, the relative humidity and the amount of frosting which has occurred.

Corrected heating capacity values, which take these factors into account, can be calculated as follows, using the correction factors for frost accumulation given in Table 2-8.11:

$$\text{Corrected heating capacity} = \text{Value given in outdoor heating capacity table} \times \text{Correction factor for frost accumulation}$$

Table 2-8.11: Correction factor for frost accumulation

Heat exchanger inlet port temperature (°C / RH 85%)		-7	-5	-2	0	2	5	7
Correction factor for frost accumulation	80/120/140 model	0.88	0.87	0.85	0.8	0.83	0.91	1
	100/160 model	0.85	0.84	0.82	0.77	0.8	0.88	1

Corrected heating capacities express the heating capacity over the heating/defrosting cycle shown in Figure 2-8.11.

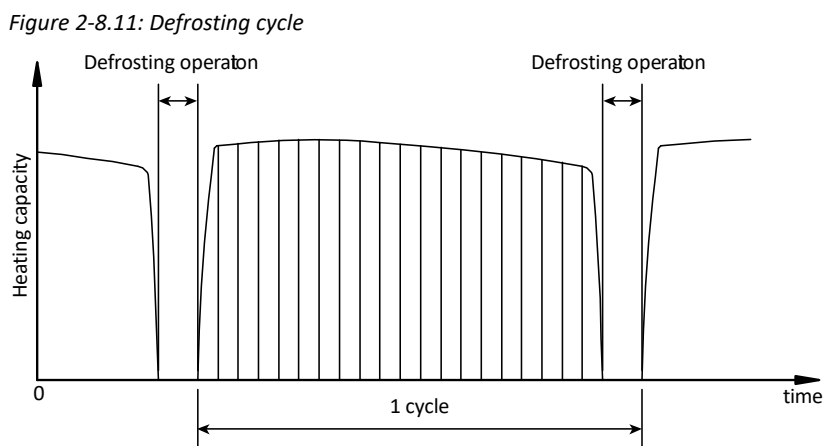

9 Operating Limits

Figure 2-9.1: Operating limits

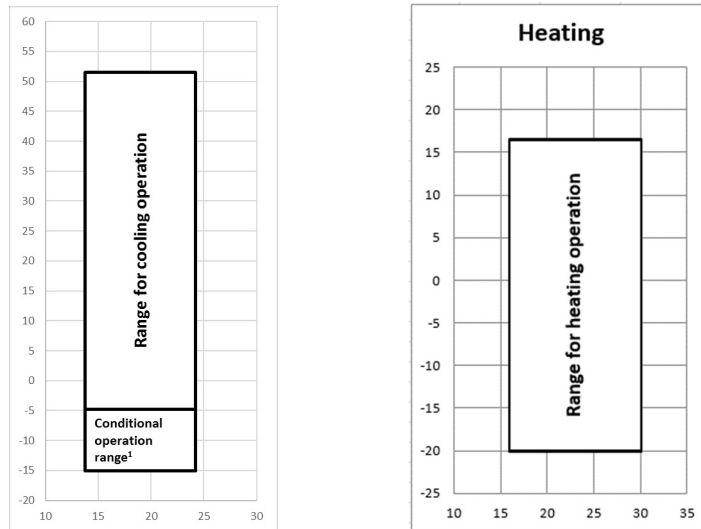

Note1: Outdoor operating temperature under -5°C in "cooling" mode, the startup capacity of IDUs must meet at least 30% of ODU capacity.

Table 2-9.1: Operating limits

Mode	Outdoor temperature/DB	Room temperature/WB
Cooling operation	-15 to $52^{\circ}\text{C}(\text{DB})$	13°C to $23^{\circ}\text{C}(\text{WB})$
Heating operating	-20°C to $16.5^{\circ}\text{C}(\text{WB})$	16°C to $30^{\circ}\text{C}(\text{DB})$
Dehumidification operating	-15°C to $52^{\circ}\text{C}(\text{DB})$	9°C to $23^{\circ}\text{C}(\text{WB})$

Notes:

1. If the unit is running outside the above condition, protective device will start, and even then the units take place abnormality running.
2. These figures base on the operation conditions between indoor units and outdoor units: Equivalent pipe length is 5m, and height difference is 0m.

Precaution:

1. The indoor relative humidity should be lower than 80%. If the air conditioner works in an environment with a relative humidity higher than mentioned above, the surface of the air conditioner may condensate. In this case, it is recommended to set the air speed of the indoor unit to high.

10 Sound Levels

10.1 Overall

Table 2-10.1: Sound pressure level

Model	dB(A)	Height (m)
MSAN8-X 80M	53	1
MSAN8-X 100M	53	1
MSAN8-X 120M/T	55	1
MSAN8-X 140M/T	56	1
MSAN8-X 160M/T	56	1

Notes:

1. Sound pressure level is measured at a position 1m in front of the unit and Hm above the floor in a semi-anechoic chamber. During in-situ operation, sound pressure levels may be higher as a result of ambient noise.

Figure 2-10.1: Sound pressure level measurement (unit: m)

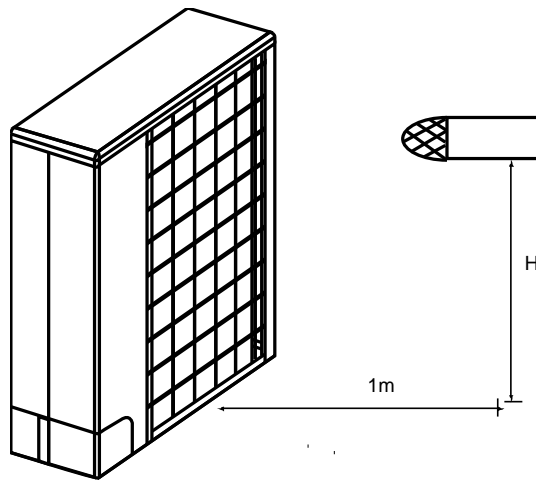

10.2 Octave Band Levels - 220-240V~50Hz

Figure 2-10.2: 80 model octave band level

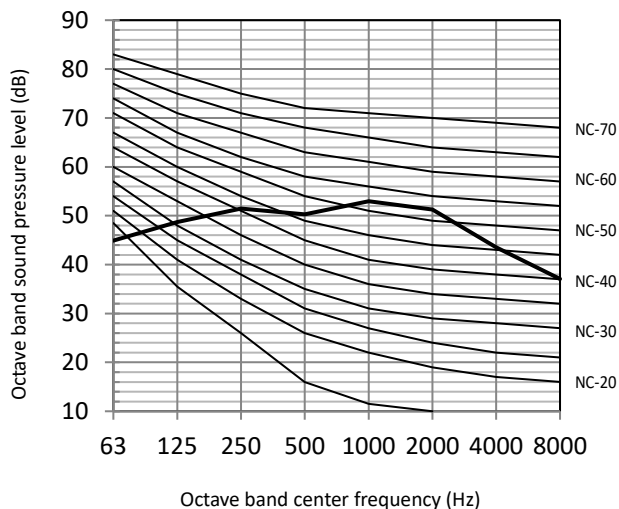

Figure 2-10.3: 100 model octave band level

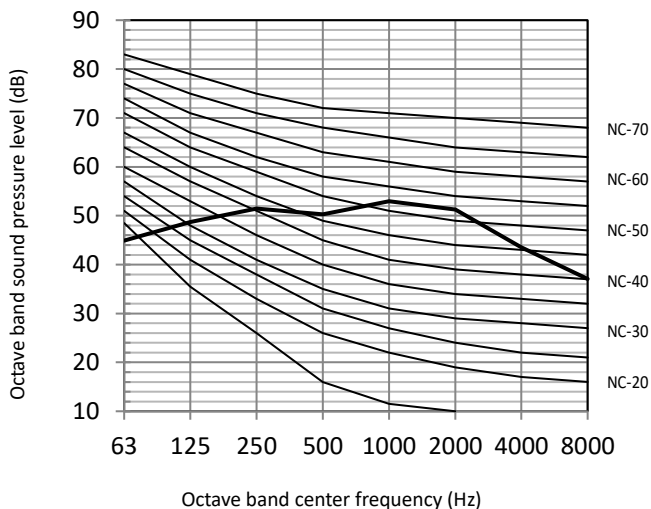

Figure 2-10.4: 120 model octave band level

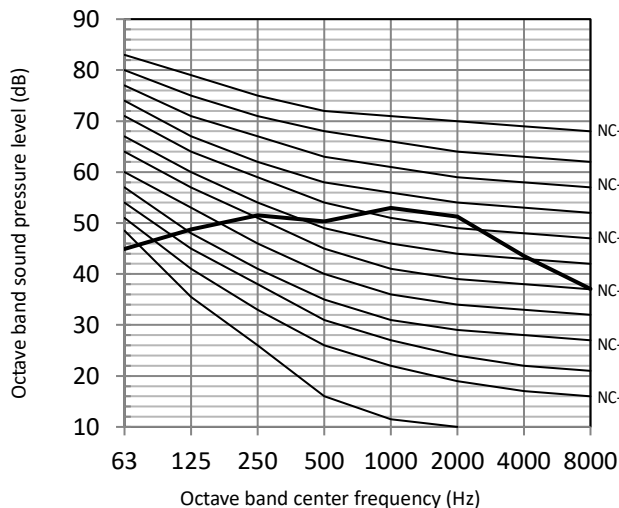

Figure 2-10.5: 140 model octave band level

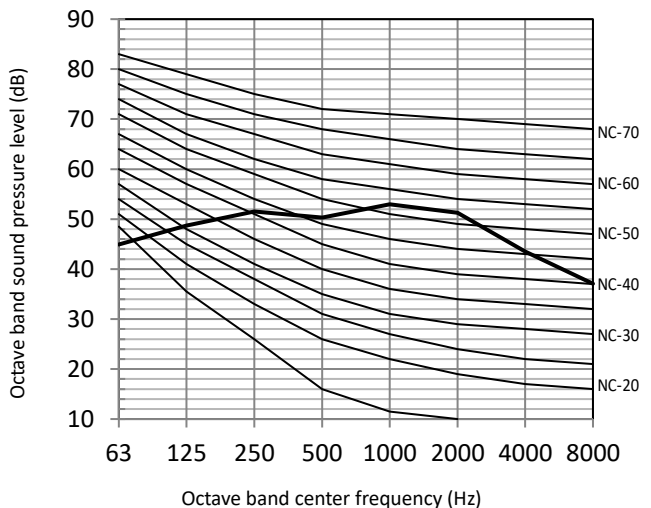
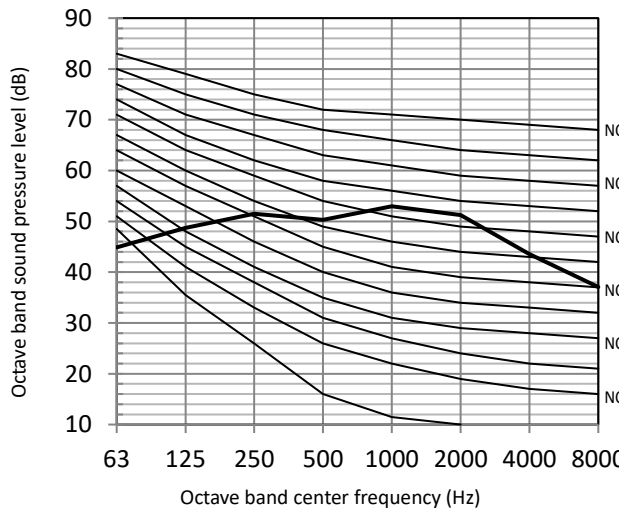

Figure 2-10.6: 160 model octave band level



10.2 Octave Band Levels - 380-415V 3N~50Hz

Figure 2-10.2: 120 model octave band level

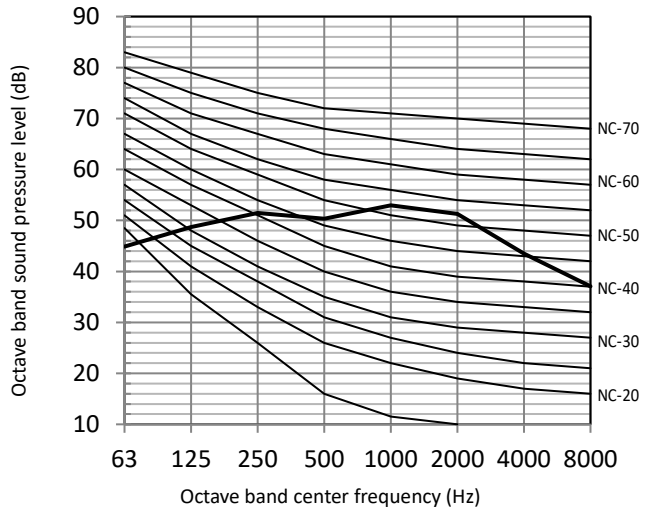

Figure 2-10.3: 140 model octave band level

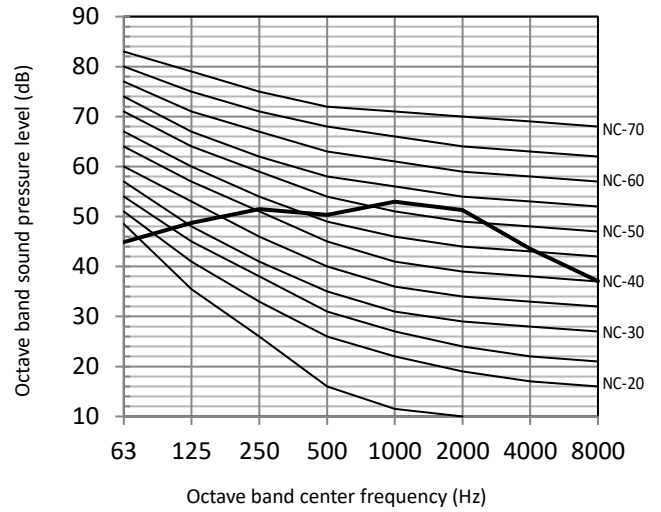
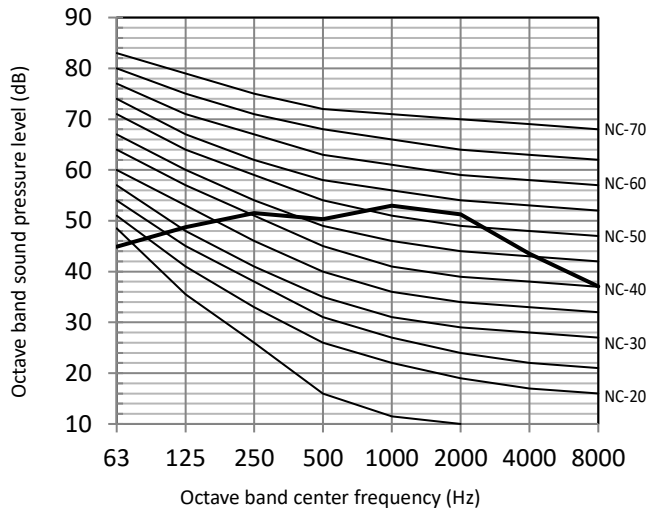







Figure 2-10.4: 160 model octave band level



11 Accessories

11.1 Standard Accessories

Table 2-11.1: Standard accessories

Name	Shape	Quantity	Function
Owner's and installation manual		1	
Water outlet connection pipe		1	
Build-out resistor		1	Enhances communication stability
Magnetic ring		1	Improve communication reliability
CN93 Auxiliary connector		1	

11.2 Optional Accessories

Table 2-11.2: Optional accessories

Optional accessories	Model	Packed dimensions (mm)	Net/gross weight (kg)	Function
Indoor branch joint kits	FQZHN-01D	290×105×100	0.3 / 0.4	Distribute refrigerant to indoor units and balance flow resistance between outdoor units
	FQZHN-02D	290×105×100	0.4 / 0.6	
	FQZHN-03D	310×130×125	0.6 / 0.9	
	FQZHN-04D	350×170×180	1.1 / 1.5	
	FQZHN-05D	365×195×215	1.4 / 1.9	
	FQZHN-06D	390×230×255	2.5 / 3.1	
	FQZHN-07D	390×230×255	2.8 / 3.4	

Part 3

System Design and Installation

1 Preface to Part 3	78
2 Unit Placement and Installation	79
3 Refrigerant Piping Design	83
4 Refrigerant Piping Installation	89
5 Drain Piping	101
6 Insulation.....	105
7 Charging Refrigerant	107
8 Electrical Wiring.....	109
9 Installation in Areas of High Salinity.....	116
10 Commissioning	117
11 Appendix to Part 3 – System Commissioning Report	121

1 Preface to Part 3

1.1 Notes for Installers Boxes

The information contained in this Engineering Data Book may primarily be of use during the system design stage of a Mini Series VRF project. Additional important information which may primarily be of use during field installation has been placed in boxes, such as the example below, titled “Notes for installers”.

Notes for installers



- Notes for installers boxes contain important information which may primarily be of use during field installation, rather than during desk-based system design.

1.2 Definitions

In this Engineering Data Book, the term “applicable legislation” refers to all national, local and other laws, standards, codes, rules, regulations and other legislation that apply in a given situation.

1.3 Precautions

All system installation including installation of piping and electrical works must only be carried out by competent and suitably qualified, certified and accredited professionals and in accordance with all applicable legislation.

2 Unit Placement and Installation

2.1 Outdoor Units

2.1.1 Placement considerations

Placement of outdoor units should take account of the following considerations:

- Air conditioners should not be exposed to direct radiation from a high-temperature heat source.
- Air conditioners should not be installed in positions where dust or dirt may affect heat exchangers.
- Air conditioners should not be installed in locations where exposure to oil or to corrosive or harmful gases, such as acidic or alkaline gases, may occur.
- Air conditioners should not be installed in locations where exposure to salinity may occur unless the anti-corrosion treatment for high-salinity areas customization option has been added and the precautions described in Part 3, 9 “Installation in Areas of High Salinity” are taken.
- Outdoor units should be installed in well-drained, well-ventilated positions that are as close as possible to the indoor units.

2.1.2 Spacing

Outdoor units must be spaced such that sufficient air may flow through each unit. Sufficient airflow across heat exchangers is essential for outdoor units to function properly. Figures 3-2.1 to 3-2.3 show spacing requirements in three different scenarios.

Figure 3-2.1: Single unit installation (unit: mm)

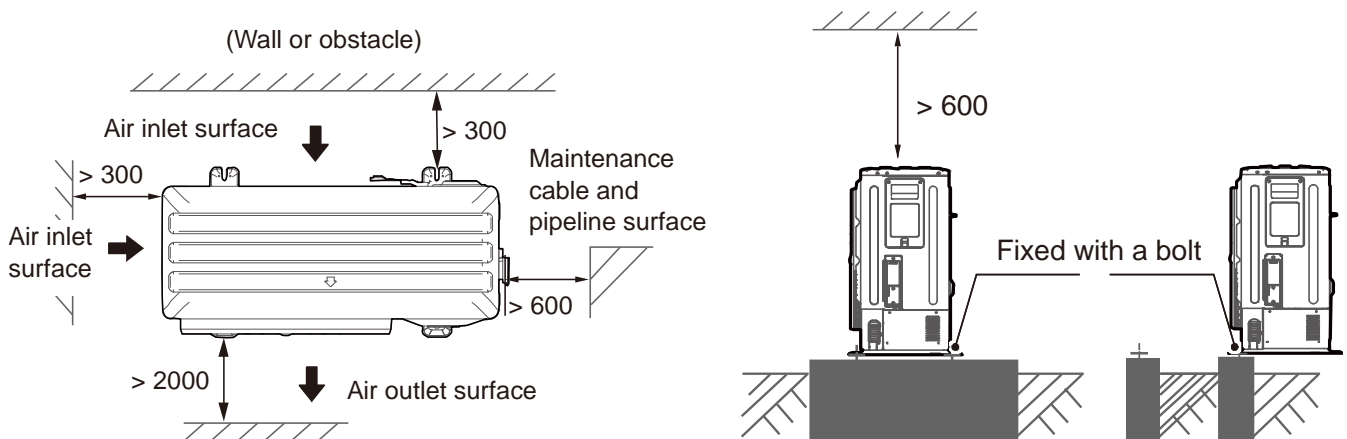

Figure 3-2.2: Parallel connect the two units or above (unit: mm)

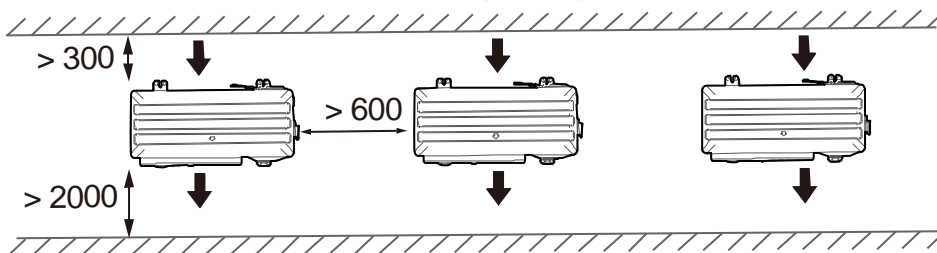
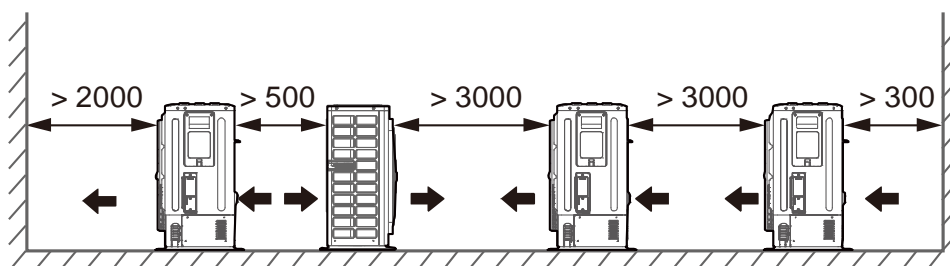

Figure 3-2.3: Parallel connect the front with rear sides (unit: mm)



2.1.3 Base structures

Outdoor unit base structure design should take account of the following considerations:

- A solid base prevents excess vibration and noise. Outdoor unit bases should be constructed on solid ground or on structures of sufficient strength to support the units' weight.
- Bases should be at least 200mm high to provide sufficient access for installation of piping.
- Either steel or concrete bases may be suitable.
- A typical concrete base design is shown in Figure 3-2.4. A typical concrete specification is 1 part cement, 2 parts sand and 6 parts crushed stone with $\Phi 10$ mm steel reinforcing bar. The edges of the base should be chamfered.
- To ensure that all contact points are equally secure, bases should be completely level. Base design should ensure that the points on the units' bases designed for weight-bearing support are fully supported.
- A drainage ditch should be provided to allow drainage of condensate that may form on the heat exchangers when the units are running in heating mode. The drainage should ensure that condensate is directed away from roadways and footpaths, especially in locations where the climate is such that condensate may freeze.

Figure 3-2.4: Outdoor unit typical concrete base structure design (unit: mm)

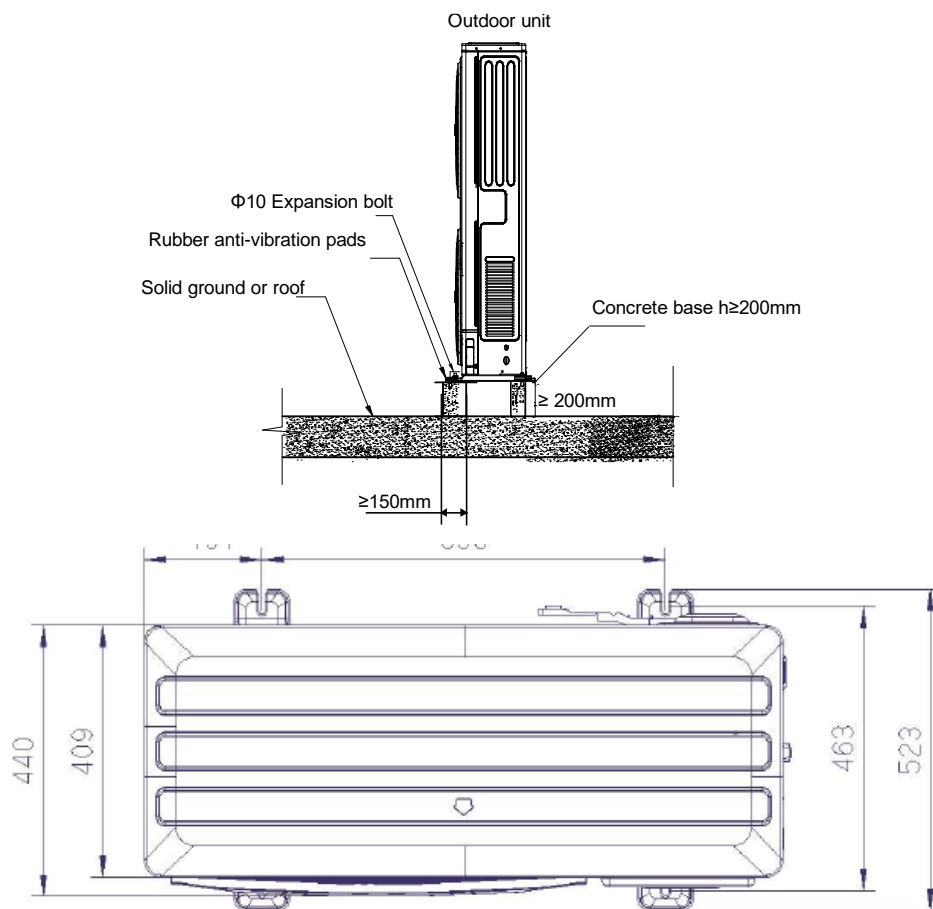

condensate drainage

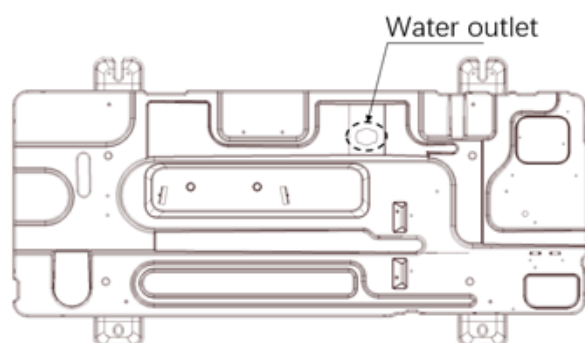

2.1.4 Acceptance and unpacking

Notes for installers



- When units are delivered check whether any damage occurred during shipment. If there is damage to the surface or outside of a unit, submit a written report to the shipping company.
- Check that the model, specifications and quantity of the units delivered are as ordered.
- Check that all accessories ordered have been included. Retain the Installation and Owner's Manual for future reference.

2.1.5 Hoisting

Notes for installers



- Do not remove any packaging before hoisting. If units are not packaged or if the packaging is damaged, use suitable boards or packing material to protect the units.
- Hoist one unit at a time, using two ropes to ensure stability.
- Keep units upright during hoisting, ensuring that the angle to the vertical does not exceed 30°.
- It is better to use a crane and two long belts to lift the unit.
- Handle the unit carefully to protect it, and note the position of the center of gravity of the unit.

2.1.6 Fan Performance - 220-240V~50Hz

The default external static pressure of outdoor units' air outlets is zero. With the steel mesh cover removed the external static pressure is 35Pa.

Figure 3-2.5: 80/100 model units fan performance

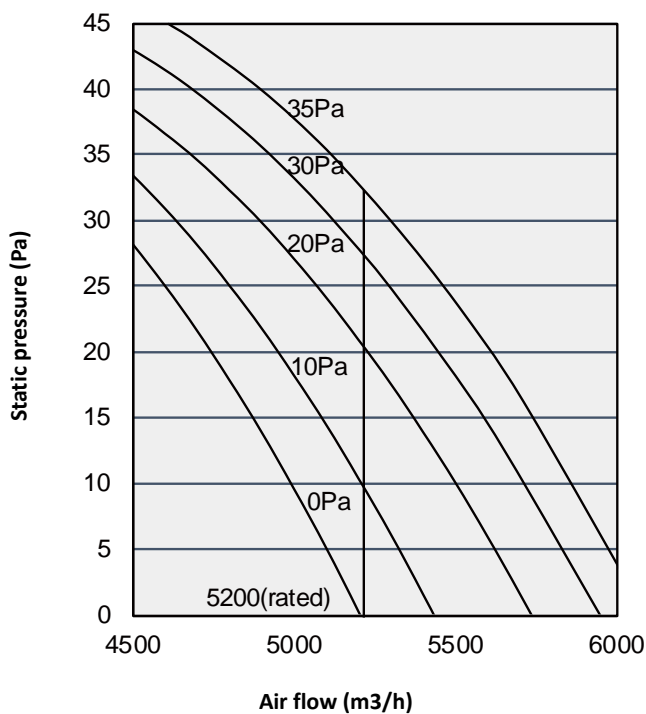
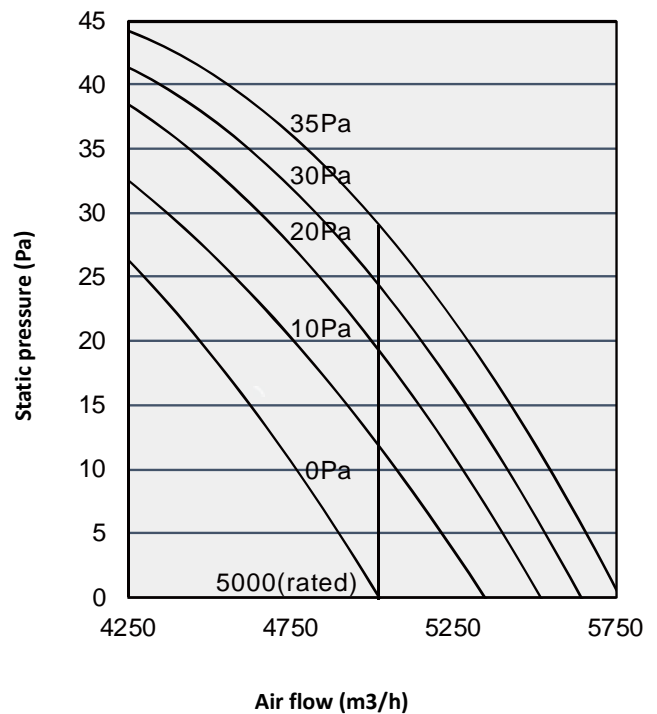

Figure 3-2.6: 120/140/160 model units fan performance



2.1.6 Fan Performance - 380-415V 3N~50Hz

The default external static pressure of outdoor units' air outlets is zero. With the steel mesh cover removed the external static pressure is 35Pa.

Figure 3-2.7: 120/140/160 model units fan performance

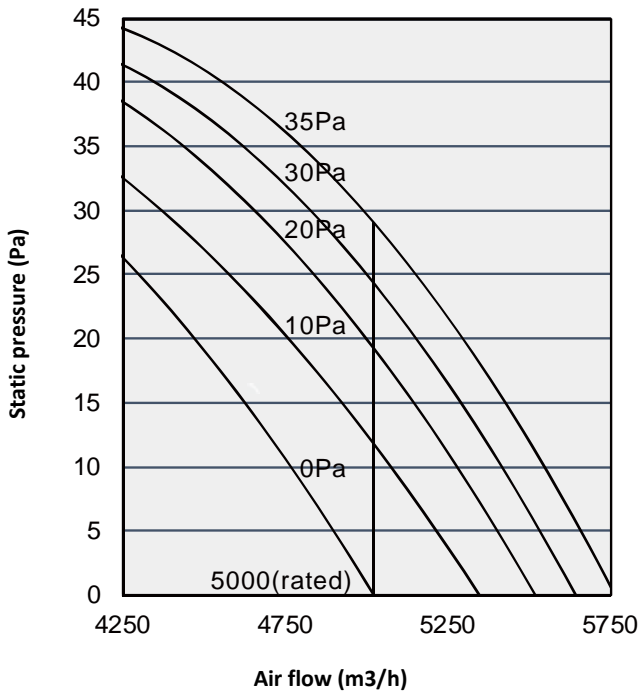

2.2 Indoor Units

2.2.1 Placement considerations

Placement of indoor units should take account of the following considerations:

- Sufficient space for drain piping and for access during servicing and maintenance should be allowed.
- To ensure a good cooling/heating effect, short-circuit ventilation (where outlet air returns quickly to a unit's air inlet) should be avoided.
- To prevent excessive noise or vibration during operation, suspension rods or other weight-bearing fixings should typically be able to bear twice the unit's weight.

Notes for installers



- Before installing an indoor unit, check that the model to be installed is as specified in the construction drawings and confirm the correct orientation of the unit.
- Ensure that units are installed at the correct height.
- To allow smooth condensate drainage and to ensure unit stability (to prevent excessive noise or vibration), ensure that units are level to within 1° of the horizontal. If a unit is not level to within 1° of the horizontal, water leakage or abnormal vibration/noise may occur.

3 Refrigerant Piping Design

3.1 Design Considerations

Refrigerant piping design should take account of the following considerations:

- The amount of brazing required should be kept to a minimum.
- On the two inside sides of the first indoor branch joint ("A" in Figures 3-3.1 and Figure 3-3.3) the system should, as far as possible, be equal in terms of number of units, total capacities and total piping lengths.

3.2 Material Specification

Only seamless phosphorus-deoxidized copper piping that complies with all applicable legislation should be used. Temper grades and minimum thicknesses for different diameters of piping are specified in Table 3-3.1.

Table 3-3.1: Piping temper and thickness

Piping outer diameter (mm)	Temper ¹	Minimum thickness (mm)
Φ6.35	O (annealed)	0.8
Φ9.53		0.8
Φ12.7		1.0
Φ15.9		1.0
Φ19.1		1.0
Φ22.2	1/2H (half hard)	1.0

Notes:

1. O: coiled piping;
2. 1/2H: straight piping.

3.3 Permitted Piping Lengths and Level Differences

The piping length and level difference requirements that apply are summarized in Table 3-3.2 and are fully described as follows (refer to Figure 3-3.1 and Figure 3-3.2):

Figure 3-3.1: Permitted refrigerant piping lengths and level differences

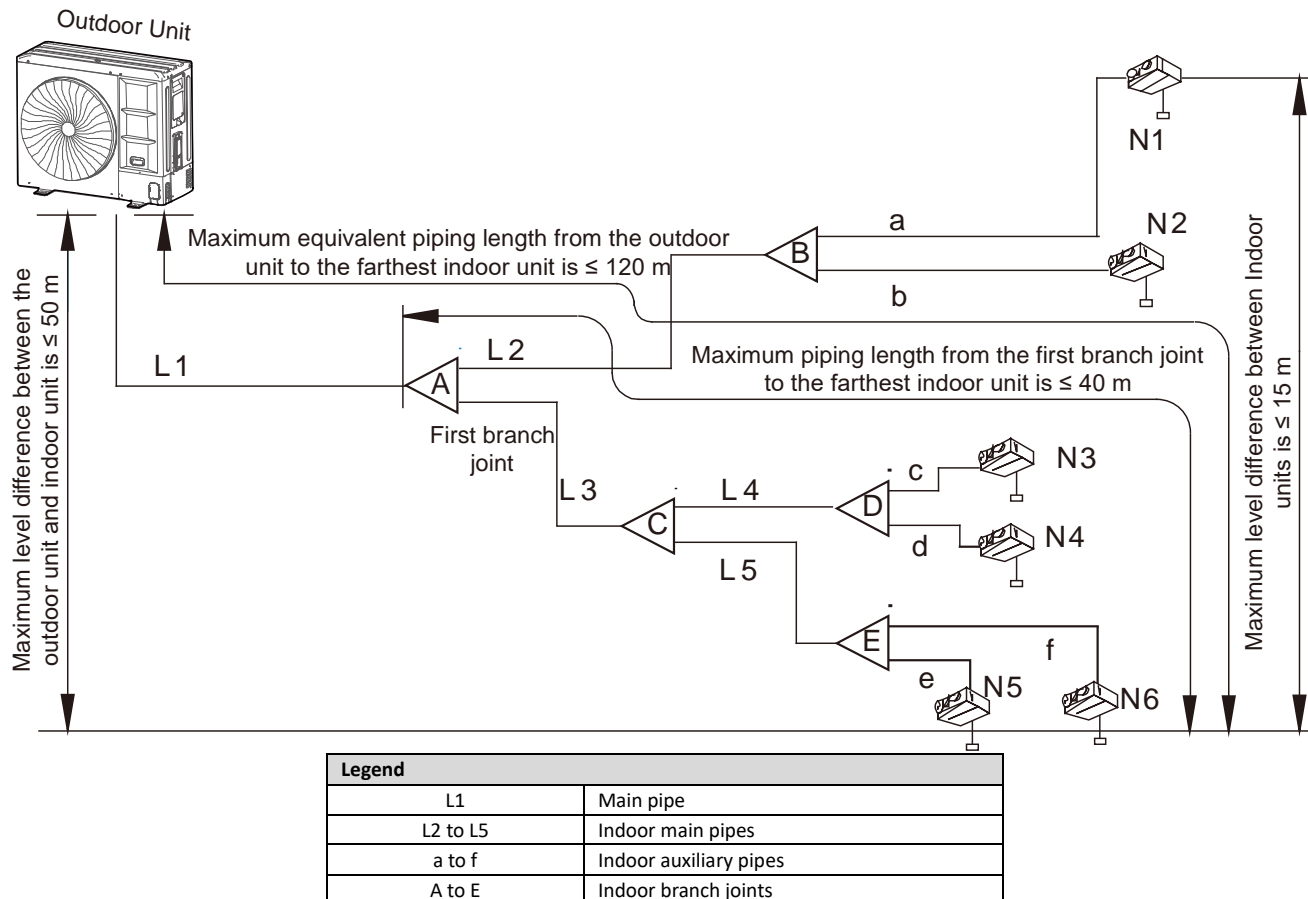

Table 3-3.2: Summary of permitted refrigerant piping lengths and level differences

Total piping length		Permitted value of liquid pipe		Piping
Pipe Length	Total Pipe Length(Actual)		≤150m(80/100 model)	L1+L2+L3+L4+L5+a+b+c+d+e+f
			≤300m(120/140/160 model)	
	Piping length between the outdoor unit and the farthest indoor unit	Actual Length	≤50m(80/100 model)	L1+L2+ max(a,b) or L1+L3+L4+max(c,d) or L1+L3+L5+max(e,f)
		Equivalent Length	≤100m(120/140/160 model)	
	Pipe Length (from the first branch to the furthest IDU)		≤60m(80/100 model)	L2+max(a,b,c,d) or L3+max(e,f,g,h,i)
			≤120m(120/140/160 model)	
Level difference	Level difference between outdoor unit and indoor units ¹	Outdoor Unit Up	≤30m(80/100 model)	----
		Outdoor Unit Up	≤50m(120/140/160 model)	
	Outdoor Unit Down	≤20m(80/100 model)	----	
		≤40m(120/140/160 model)		
	Level difference between indoor units		≤15m	----

Requirement 1: It is recommended that an oil return bend with dimensions as specified in Figure 3-3.2 is set every 10 m in the gas pipe of the main pipe.

Figure 3-3.2: Oil return bend

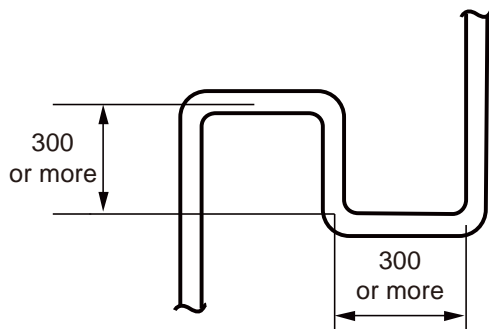

Table 3-3.3: Connectable indoor units

Outdoor unit model	Maximum number of connected indoor units	Connectable indoor unit capacity range	
		50%~160% ¹	50%~130% ¹
MSAN8-X 80M	5	36 to 115.2	36 to 93.6
MSAN8-X 100M	6	45 to 144	45 to 117
MSAN8-X 120M	8	61.5 to 196.8	61.5 to 159.9
MSAN8-X 140M	10	70 to 224	70 to 182
MSAN8-X 160M	11	77.5 to 248	77.5 to 201.5
MSAN8-X 120T	8	61.5 to 196.8	61.5 to 159.9
MSAN8-X 140T	10	70 to 224	70 to 182
MSAN8-X 160T	11	77.5 to 248	77.5 to 201.5

- Notes:
1. If all indoor units in system are V8 Series the total combination ratio must not exceed 160%. If there are non V8 series indoor unit in system the total combination ratio must not exceed 130%.

3.4 Selecting Piping Diameters

Tables 3-3.4 to 3-3.7 below, specify the required pipe diameters for the indoor and outdoor piping. The main pipe (L1) and first indoor branch joint (A) should be sized according to whichever of Tables 3-3.4 and 3-3.5 indicates the larger size.

Figure 3-3.3: Selecting piping diameters

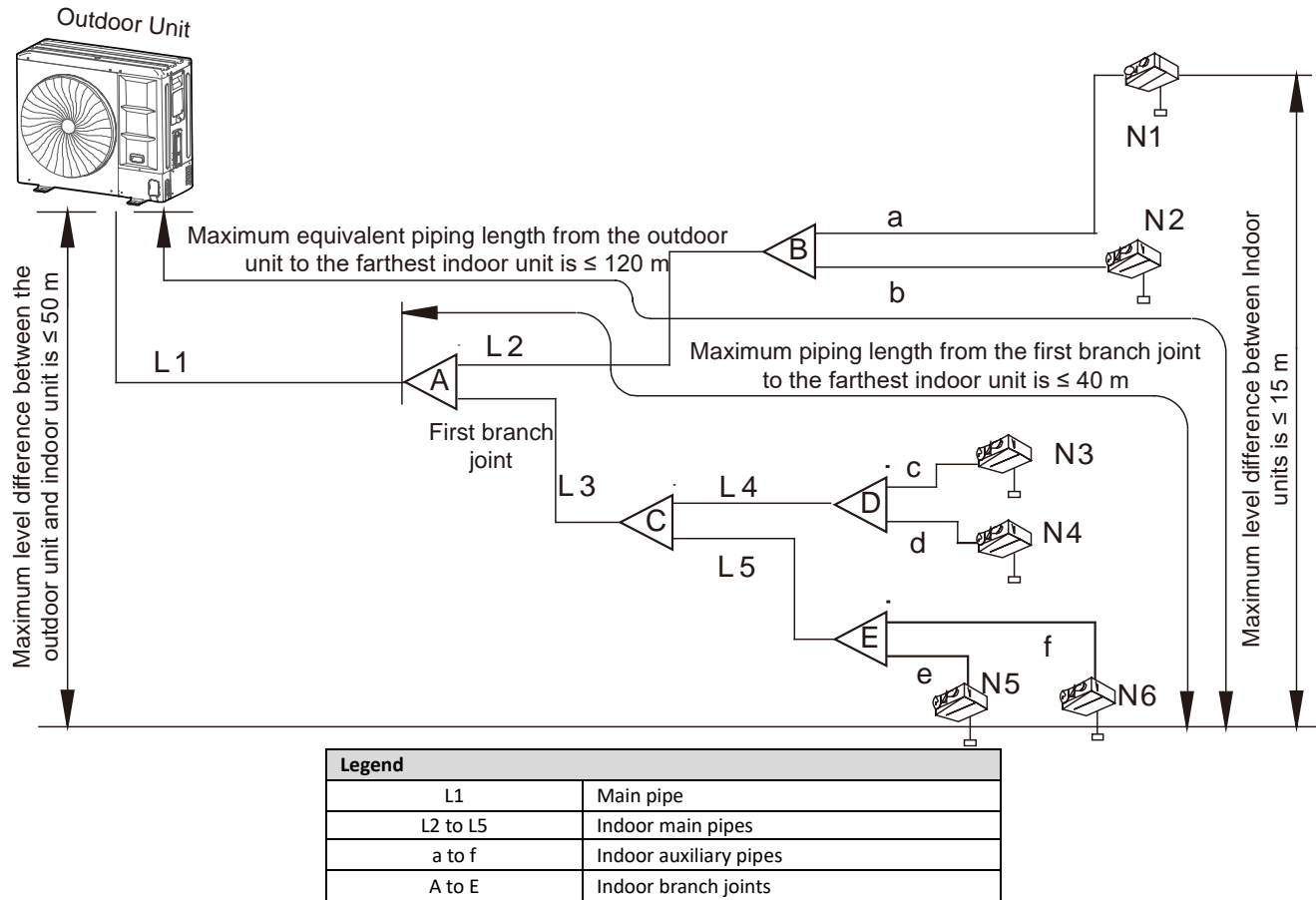

Table 3-3.4: Main pipe (L1) and first indoor branch joint (A)

Outdoor unit model	Total equivalent length of liquid pipe and gas pipe < 90m			Total equivalent length of liquid pipe and gas pipe ≥ 90 m		
	Gas pipe (mm)	Liquid pipe (mm)	Branch joint kit	Gas pipe (mm)	Liquid pipe (mm)	Branch joint kit
80	$\Phi 15.9$	$\Phi 9.52$	FQZHN-01D	$\Phi 19.1$	$\Phi 9.52$	FQZHN-01D
100	$\Phi 15.9$	$\Phi 9.52$	FQZHN-01D	$\Phi 19.1$	$\Phi 9.52$	FQZHN-01D
120	$\Phi 15.9$	$\Phi 9.52$	FQZHN-01D	$\Phi 19.1$	$\Phi 9.52$	FQZHN-01D
140	$\Phi 15.9$	$\Phi 9.52$	FQZHN-01D	$\Phi 19.1$	$\Phi 9.52$	FQZHN-01D
160	$\Phi 19.1$	$\Phi 9.52$	FQZHN-01D	$\Phi 22.2$	$\Phi 9.52$	FQZHN-01D

Table 3-3.5: Indoor main pipes (L2 to L5) and indoor branch joint kits

Total capacity indexes of indoor units	Gas pipe (mm)	Liquid pipe (mm)	Branch joint kit
Capacity indexes < 160	$\Phi 15.9$	$\Phi 9.52$	FQZHN-01D
$160 \leq$ Capacity indexes < 280	$\Phi 19.1$	$\Phi 9.52$	FQZHN-01D

Notes:

1. If indoor main pipes (L2 to L5) are larger than the main pipe (L1), indoor main pipes should reduce to the main pipe's size.

Table 3-3.6: Indoor auxiliary pipes (a to f)

Capacity of indoor unit (A $\times 100$ W)	Gas pipe (mm)	Liquid pipe (mm)
A < 63	$\Phi 12.7$	$\Phi 6.35$
$63 \leq A \leq 160$	$\Phi 15.9$	$\Phi 9.52$

Table 3-3.7: Pipe diameter of the outdoor unit itself

Outdoor unit model	Gas pipe (mm)	Liquid pipe (mm)
80/100/120/140	$\Phi 15.9$	$\Phi 9.52$
160	$\Phi 15.9$	$\Phi 9.52$

3.5 Refrigerant Piping Selection Example

The example below illustrates the piping selection procedure for a system consisting of an outdoor unit (160 model) and 6 indoor units (2.2 kW×1+2.8 kW×5), as shown in Figure 3-3.4. The system's total equivalent length of all liquid and gas pipes is less than 90m.

Figure 3-3.4: Refrigerant piping selection example

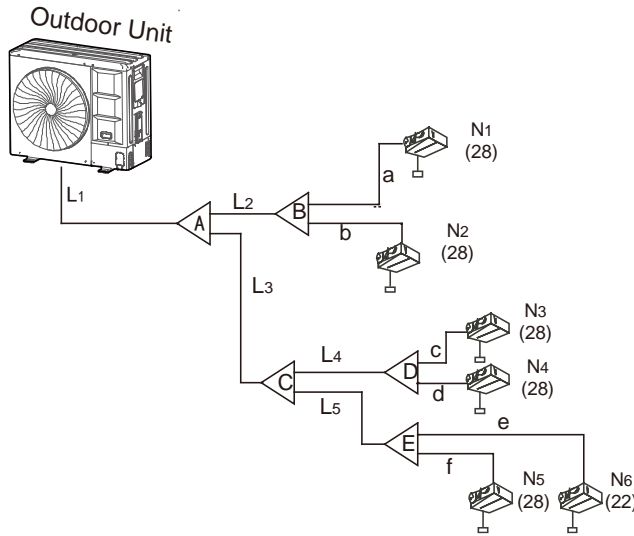

Legend	
L1	Main pipe
L2 to L5	Indoor main pipes
a to f	Indoor auxiliary pipes
A to E	Indoor branch joints
Figures in parentheses indicate indoor unit capacity indexes.	

Step 1: Select indoor auxiliary pipes a to f

- The capacity of indoor units N1 to N6 are less than 6.3kW. Refer to Table 3-3.6. Indoor auxiliary pipes a to f are $\Phi 12.7 / \Phi 6.35$.

Step 2: Select indoor main pipes (L2 to L5) and indoor branch joints B to E

Refer to Table 3-3.5

- The indoor units (N1 and N2) downstream of indoor branch B have a total capacity of $2.8 \times 2 = 5.6$ kW. Indoor main pipe L2 is $\Phi 15.9 / \Phi 9.52$. Indoor branch joint B is FQZHN-01D.
- The indoor units (N3 and N4) downstream of indoor branch D have a total capacity of $2.8 \times 2 = 5.6$ kW. Indoor main pipe L4 is $\Phi 15.9 / \Phi 9.52$. Indoor branch joint D is FQZHN-01D.
- The indoor units (N5 and N6) downstream of indoor branch E have a total capacity of $2.8 + 2.2 = 5.0$ kW. Indoor main pipe L5 is $\Phi 15.9 / \Phi 9.52$. Indoor branch joint E is FQZHN-01D.
- The indoor units (N3 to N6) downstream of indoor branch C have a total capacity of $5.6 + 5.0 = 10.6$ kW. Indoor main pipe L3 is $\Phi 15.9 / \Phi 9.52$. Indoor branch joint C is FQZHN-01D.

Step 3: Select main pipe (L1) and indoor branch joint A

- The indoor units (N1 to N6) downstream of indoor branch joint A have a total capacity of $5.6 + 10.6 = 16.2$ kW. The system's total equivalent length of all liquid and gas pipes is less than 90m. The outdoor units model is 160. Main pipe L1 is $\Phi 19.1 / \Phi 9.52$. First Indoor branch A is FQZHN-01D. Refer to Table 3-3.6.

3.6 Branch Joints

Branch joint design should take account of the following:

- U-shaped branch joints should be used – tee joints are not suitable. Branch joint dimensions are given in Tables 3-3.8.
- To ensure even distribution of refrigerant, branch joints should not be installed within 500mm of a 90° bend, another branch joint or the straight section of piping leading to an indoor unit, with the minimum 500mm being measured from the point where the branch joint is connected to the piping, as shown in Figure 3-3.5.

Figure 3-3.5: Branch joint spacing and separation from bends (unit: mm)

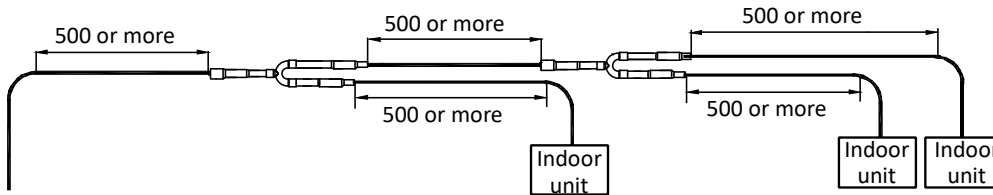

Table 3-3.8: Indoor branch joint dimensions (unit: mm)

Model	Gas side joints	Liquid side joints
FQZHN-01D		
FQZHN-02D		

3.7 Refrigerant Leakage Precautions

R410A refrigerant is not flammable in air at temperatures up to 100°C at atmospheric pressure and is generally considered a safe substance to use in air conditioning systems. Nevertheless, precautions should be taken to avoid danger to life in the unlikely event of a major refrigerant leakage. Precautions should be taken in accordance with all applicable legislation. Where no applicable legislation exists, the following may be used as a guide:

- Air conditioned rooms should be large enough that if leakage of all the refrigerant in the system occurs, the concentration of the refrigerant in the room does not reach a level dangerous to health.
- A critical concentration (at which point R410A becomes dangerous to human health) of 0.44 kg/m³ can be used.
- The potential concentration of refrigerant in a room following a leak can be calculated as follows:
 - Calculate the total amount in of refrigerant in the system (“A”) as the nameplate charge (the charge in the system when delivered from the factory) plus the additional charge added as per Part 3, 7.1 “Calculating Additional Refrigerant Charge”.
 - Calculate the total volume (“B”) of the smallest room into which refrigerant could potentially leak.
 - Calculate the potential refrigerant concentration as A divided by B.
 - If A/B is not less than 0.44 kg/m³, countermeasures such installing mechanical ventilators (either ventilating regularly or controlled by refrigerant leakage detectors) should be taken.
- Since R410A is heavier than air, particular consideration should be given to leak scenarios in basement rooms.

Figure 3-3.6: Potential refrigerant leak scenario

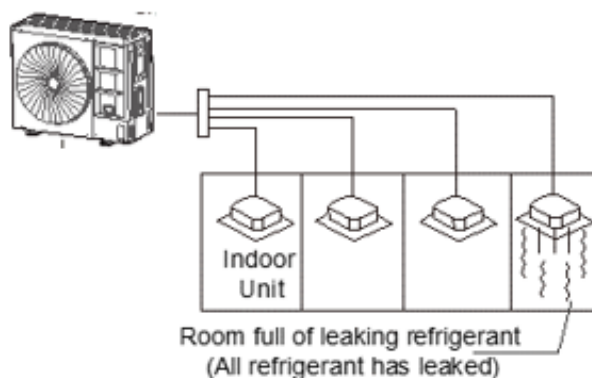
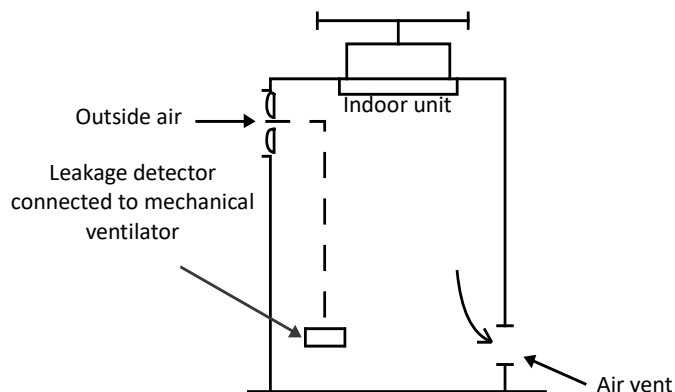

Figure 3-3.7: Mechanical ventilator controlled by refrigerant leak detector



4 Refrigerant Piping Installation

4.1 Procedure and Principles

4.1.1 Installation procedure

Notes for installers

Installation of the refrigerant piping system should proceed in the following order:

Pipe insulation

Pipe brazing and installation

Pipe flushing

Gastightness test

Joint insulation

Vacuum drying

Note: Pipe flushing should be performed once the brazed connections have been completed with the exception of the final connections to the indoor units. That is, flushing should be performed once the outdoor units have been connected but before the indoor units are connected.

4.1.2 Three principles for refrigerant piping

	Reasons	Measures
CLEAN	Particles such as oxide produced during brazing and/or building dust can lead to compressor malfunction	<ul style="list-style-type: none"> Seal piping during storage¹ Flow nitrogen during brazing² Pipe flushing³
DRY	Moisture can lead to ice formation or oxidization of internal components leading to abnormal operation or compressor damage	<ul style="list-style-type: none"> Pipe flushing³ Vacuum drying⁴
SEALED	Imperfect seals can lead to refrigerant leakage	<ul style="list-style-type: none"> Pipe manipulation⁵ and brazing² techniques Gastightness test⁶

Notes:

1. See Part 3, 4.2.1 "Pipe delivery, storage and sealing".
2. See Part 3, 4.5 "Brazing".
3. See Part 3, 4.8 "Pipe Flushing".
4. See Part 3, 4.10 "Vacuum Drying".
5. See Part 3, 4.3 "Manipulating Copper Piping".
6. See Part 3, 4.9 "Gastightness Test".

4.2 Storing Copper Piping

4.2.1 Pipe delivery, storage and sealing

Notes for installers



- Ensure that piping does not get bent or deformed during delivery or whilst stored.
- On construction sites store piping in a designated location.
- To prevent dust or moisture entering, piping should be kept sealed whilst in storage and until it is about to be connected. If piping is to be used soon, seal the openings with plugs or adhesive tape. If piping is to be stored for a long time, charge the piping with nitrogen at 0.2-0.5MPa and seal the openings by brazing.
- Storing piping directly on the ground risks dust or water ingress. Wooden supports can be used to raise piping off the ground.
- During installation, ensure that piping to be inserted through a hole in a wall is sealed to ensure dust and/or fragments of wall do not enter.
- Be sure to seal piping being installed outdoors (especially if being installed vertically) to prevent rain entering.

4.3 Manipulating Copper Piping

4.3.1 De-oiling

Notes for installers



- Lubrication oil used during some copper pipe manufacturing processes can cause deposits to form in R410A refrigerant systems, causing system errors. Oil-free copper piping should therefore be selected. If ordinary (oily) copper piping is used, it must be cleaned with gauze dipped in tetrachloroethylene solution prior to installation.

Caution

- Never use carbon tetrachloride (CCl₄) for pipe cleansing or flushing, as doing so will seriously damage the system.

4.3.2 Cutting copper piping and removing burrs

Notes for installers



- Use a pipe cutter rather than a saw or cutting machine to cut piping. Rotate the piping evenly and slowly, applying even force to ensure that the piping does not become deformed during cutting. Using a saw or cutting machine to cut piping runs the risk of copper shavings entering the piping. Copper shavings are difficult to remove and pose a serious risk to the system if they enter the compressor or block the throttling unit.
- After cutting using a pipe cutter, use a reamer/scrapper to remove any burrs that have formed at the opening, keeping the opening of the piping downwards to avoid copper shavings from entering the piping.
- Remove burrs carefully to avoid scratches, which may prevent a proper seal being formed and lead to refrigerant leakage.

4.3.3 Expanding copper piping ends

Notes for installers



- Ends of copper piping can be expanded so that another length of piping can be inserted and the joint brazed.
- Insert the expanding head of the pipe expander into the pipe. After completing pipe expansion, rotate the copper pipe a few degrees to rectify the straight line mark left by the expanding head.

Caution

- Ensure that the expanded section of piping is smooth and even. Remove any burrs that remain after cutting.

Figure 3-4.1: Expanding copper piping ends

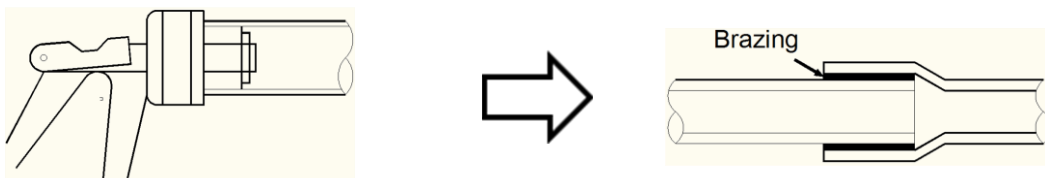

4.3.4 Flared joints

Flared joints should be used where a screw thread connection is required.

Notes for installers



- Before flaring 1/2H (half hard) piping, anneal the end of the pipe to be flared.
- Remember to place the flare nut on the piping before flaring.
- Ensure the flared opening is not cracked, deformed or scratched, otherwise it will not form a good seal and refrigerant leakage may occur.
- The diameter of the flared opening should be within the ranges specified in Table 3-4.1. Refer to Figure 3-4.2.

Table 3-4.1: Flared opening size ranges

Pipe (mm)	Flared opening diameter (A) (mm)
Φ6.35	8.7 - 9.1
Φ9.52	12.8 - 13.2
Φ12.7	16.2 - 16.6
Φ15.9	19.3 - 19.7
Φ19.1	23.6 - 24.0

Figure 3-4.2: Flared opening

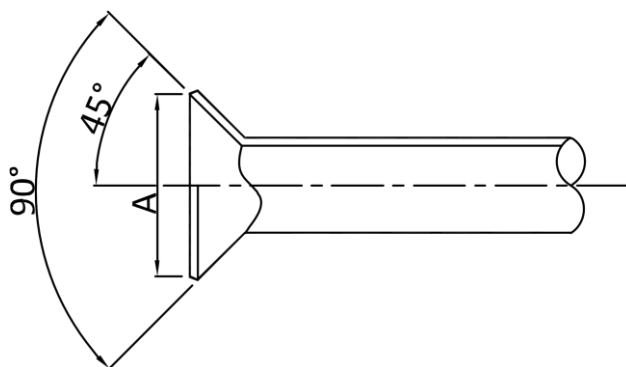

- When connecting a flared joint, apply some compressor oil to the inner and outer surfaces of the flared opening

4.3.5 Bending piping

Bending copper piping reduces the number of brazed joints required and can improve quality and save material.

Notes for installers



Piping bending methods

- Hand bending is suitable for thin copper piping ($\Phi 6.35\text{mm} - \Phi 12.7\text{mm}$).
- Mechanical bending (using a bending spring, manual bending machine or powered bending machine) is suitable for a wide range of diameters ($\Phi 6.35\text{mm} - \Phi 54.0\text{mm}$).

Caution

- When using a spring bender, ensure that the bender is clean before inserting it in the piping.
- After bending a copper pipe, ensure that there are no wrinkles or deformation on either side of the pipe.
- Ensure that bend angles do not exceed 90° , otherwise wrinkles may appear on the inner side of the pipe, and the pipe may buckle or crack. Refer to Figure 3-4.3.
- Do not use a pipe that has buckled during the bending process; ensure that the cross section at the bend is greater than $2/3$ of the original area.

Figure 3-4.3: Pipe bending in excess of 90°

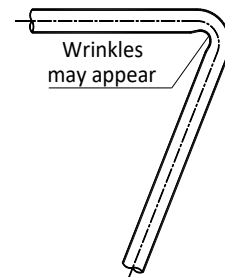

4.4 Refrigerant Piping Supports

When the air conditioning is running, the refrigerant piping will deform (shrink, expand, droop). To avoid damage to piping, hangers or supports should be spaced as per the criteria in the Table 3-4.2. In general, the gas and liquid pipes should be suspended in parallel and the interval between support points should be selected according to the diameter of the gas pipe.

Table 3-4.2: Refrigerant piping support spacings

Pipe (mm)	Interval between support points (m)	
	Horizontal Piping	Vertical Piping
$< \Phi 20$	1	1.5
$\Phi 20 - \Phi 40$	1.5	2
$> \Phi 40$	2	2.5

Suitable insulation should be provided between the piping and the supports. If wooden dowels or blocks are to be used, use wood that has undergone preservative treatment.

Changes in refrigerant flow direction and refrigerant temperature result in movement, expansion and shrinkage of the refrigerant piping. Piping should therefore not be fixed too tightly, otherwise stress concentrations may occur in the piping, with the potential for rupturing.

4.5 Brazing

Care must be taken to prevent oxide forming on the inside of copper piping during brazing. The presence of oxide in a refrigerant system adversely affects the operation of valves and compressors, potentially leading to low efficiency or even compressor failure. To prevent oxidation, during brazing nitrogen should be flowed through the refrigerant piping.

Notes for installers



Warning

- Never flow oxygen through piping as doing so aids oxidation and could easily lead to explosion and as such is extremely dangerous.
- Take appropriate safety precautions such as having a fire extinguisher to hand whilst brazing.

Flowing nitrogen during brazing

- Use a pressure reducing valve to flow nitrogen through copper piping at 0.02-0.03MPa during brazing.
- Start the flow before brazing starts and ensure that the nitrogen continuously passes through the section being brazed until the brazing is complete and the copper has cooled down completely.

Figure 3-4.4: Flowing nitrogen through piping during brazing

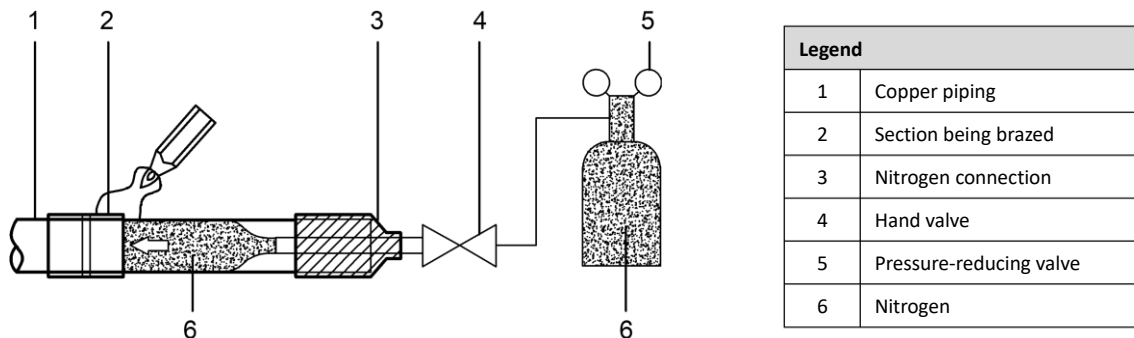

- When joining a shorter section of piping to a longer section, flow nitrogen from the shorter side to allow better displacement of air with nitrogen.
- If the distance from the point where nitrogen enters the piping to the joint to be brazed is long, ensure that the nitrogen is flowed for sufficient time to discharge all the air from the section to be brazed before commencing brazing.

Figure 3-4.5: Flowing nitrogen from shorter side during brazing

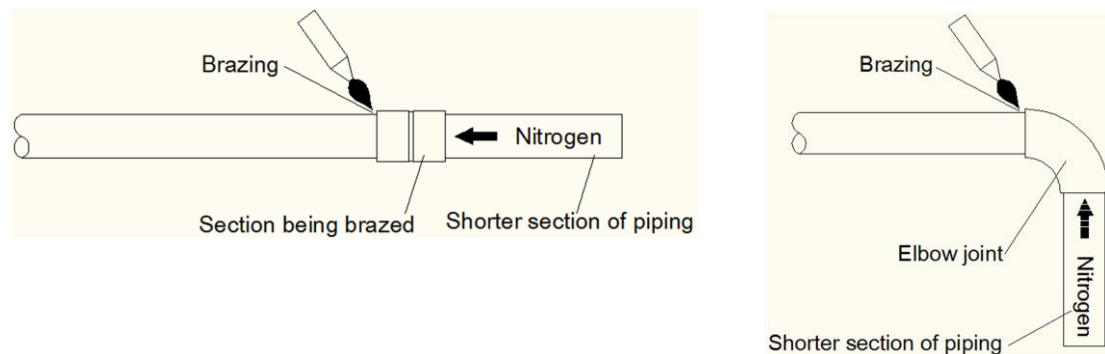

Box continued on next page ...

Piping orientation during brazing

Brazing should be conducted downwards or horizontally to avoid filler leakage.

Figure 3-4.6: Piping orientation during brazing

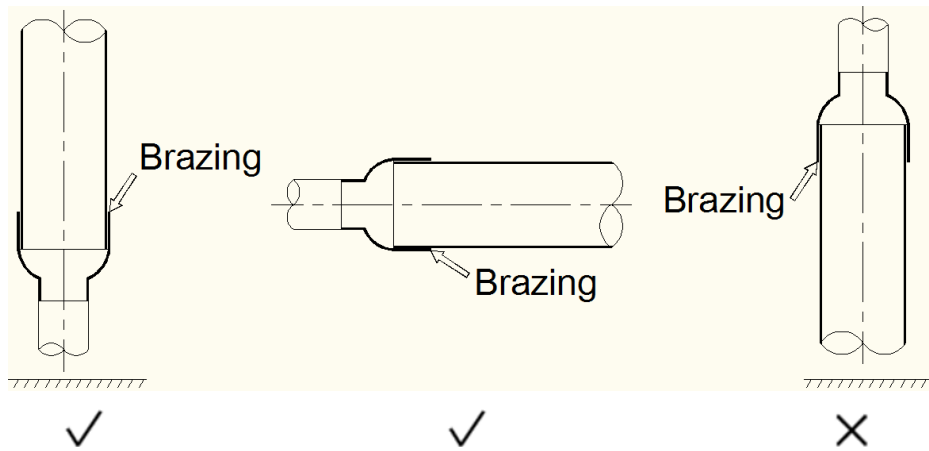

Piping overlap during brazing

Table 3-4.3 specifies the minimum permissible piping overlap and the range of permissible gap sizes for brazed joints on piping of different diameters. Refer also to Figure 3-4.7.

Figure 3-4.7: Piping overlap and gap for brazed joints

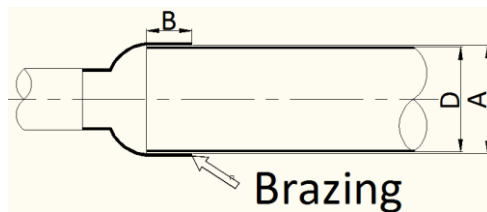

Legend	
A	Inner diameter of larger pipe
D	Outer diameter of smaller pipe
B	Inlaid depth (overlap)

Table 3-4.3: Piping overlap and gap for brazed joints¹

D (mm)	Minimum permissible B (mm)	Permissible A – D (mm)
5 < D < 8	6	0.05 - 0.21
8 < D < 12	7	
12 < D < 16	8	0.05 - 0.27
16 < D < 25	10	
25 < D < 35	12	0.05 - 0.35
35 < D < 45	14	

Notes:

1. A, B, D refer to the dimensions shown in Figure 3-4.7.

Filler

- Use a copper/phosphorus brazing alloy (BCuP) filler that does not require flux.
- Do not use flux. Flux can cause corrosion of piping and can affect the performance of compressor oil.
- Do not use anti-oxidants when brazing. Residue can clog piping and damage components.

4.6 Branch Joints

Notes for installers



- Use U-shaped branch joints as specified on the construction drawings – do not replace U-shaped branch joints with tee joints.
- Indoor branch joints may be installed either horizontally or vertically. Horizontal branch joints must be installed at an angle to the horizontal not exceeding 10° in order to avoid uneven distribution of refrigerant and possible malfunction. Refer to Figure 3-4.8.

Figure 3-4.8: Branch joint orientation

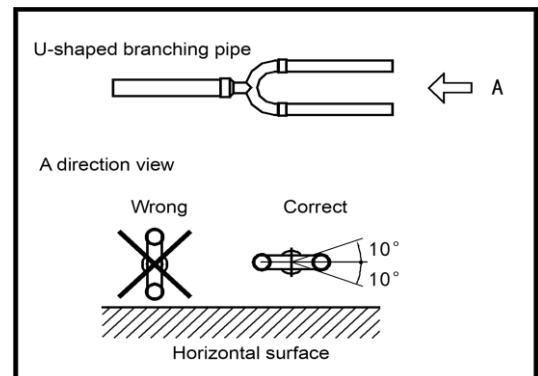

- To ensure even distribution of refrigerant, branch joints should not be installed within 500mm of a 90° bend, another branch joint or the straight section of piping leading to an indoor unit, with the minimum 500mm being measured from the point where the branch joint is connected to the piping, as shown below.

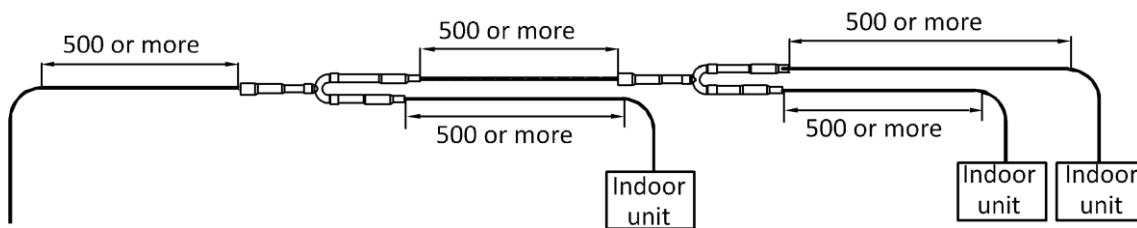

4.7 Direction of refrigerant pipe connection

Field piping can be connected in 4 directions. Before connecting, knock off the plate in the corresponding direction.

Figure 3-4.9: Direction of refrigerant pipe connection

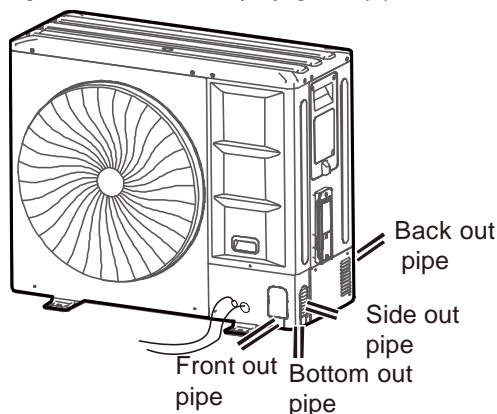

Figure 3-4.10: The connection method of the forward outlet pipe

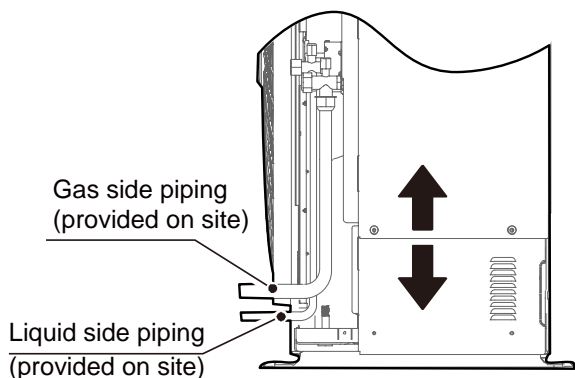

Figure 3-4.12: The connection method of the downward outlet pipe.

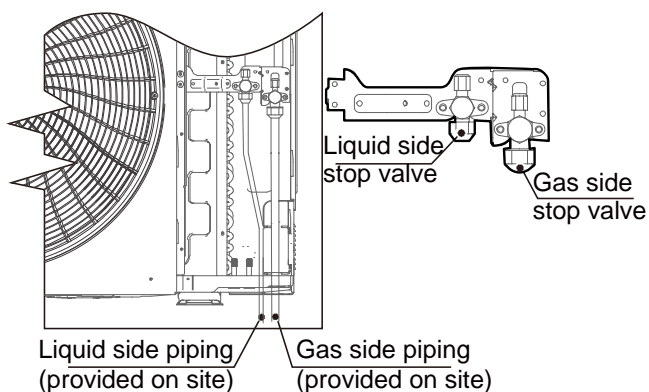

Figure 3-4.11: The connection method of the rightward outlet pipe.

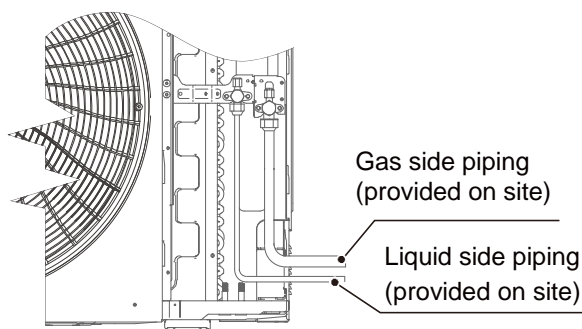
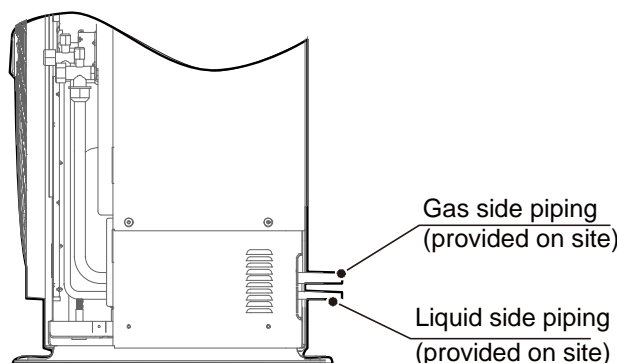

Figure 3-4.13: The connection method of the backward outlet pipe.



4.8 Pipe Flushing

4.8.1 Purpose

To remove dust, other particles and moisture, which could cause compressor malfunction if not flushed out before the system is run, the refrigerant piping should be flushed using nitrogen. As described in Part 3, 4.1.1 "Installation procedure", pipe flushing should be performed once the piping connections have been completed with the exception of the final connections to the indoor units. That is, flushing should be performed once the outdoor units have been connected but before the indoor units are connected.

4.8.2 Procedure

Notes for installers



Warning

Only use nitrogen for flushing. Using carbon dioxide risks leaving condensation in the piping. Oxygen, air, refrigerant, flammable gases and toxic gases must not be used for flushing. Use of such gases may result in fire or explosion.

Procedure

The liquid and gas sides can be flushed simultaneously; alternatively, one side can be flushed first and then Steps 1 to 8 repeated, for the other side. The flushing procedure is as follows:

1. Cover the inlets and outlets of the indoor units to prevent dirt getting blown in during pipe flushing. (Pipe flushing should be carried out before connecting the indoor units to the piping system.)
2. Attach a pressure reducing valve to a nitrogen cylinder.
3. Connect the pressure reducing valve outlet to the inlet on the liquid (or gas) side of the outdoor unit.
4. Use blind plugs to block all liquid (gas) side openings, except for the opening at the indoor unit which is furthest from the outdoor units ("Indoor unit A" in Figure 3-4.14).
5. Start to open the nitrogen cylinder valve and gradually increase the pressure to 0.5MPa.
6. Allow time for nitrogen to flow as far as the opening at indoor unit A.
7. Flush the first opening:
 - a) Using suitable material, such as a bag or cloth, press firmly against the opening at indoor unit A.
 - b) When the pressure becomes too high to block with your hand, suddenly remove your hand allowing gas to rush out.
 - c) Repeatedly flush in this manner until no further dirt or moisture is emitted from the piping. Use a clean cloth to check for dirt or moisture being emitted. Seal the opening once it has been flushed.
8. Flush the other openings in the same manner, working in sequence from indoor unit A towards the outdoor units. Refer to Figure 3-4.15.
9. Once flushing is complete, seal all openings to prevent dust and moisture from entering.

Figure 3-4.14: Pipe flushing using nitrogen

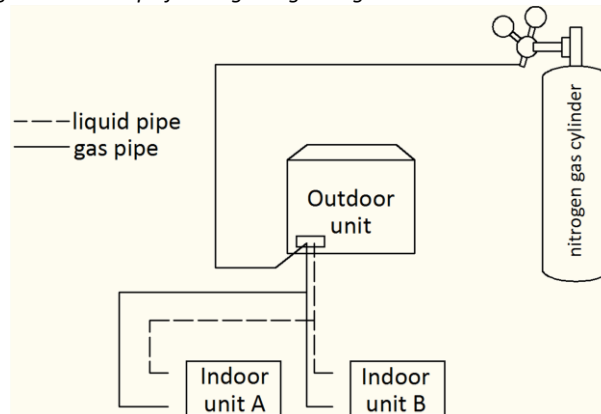
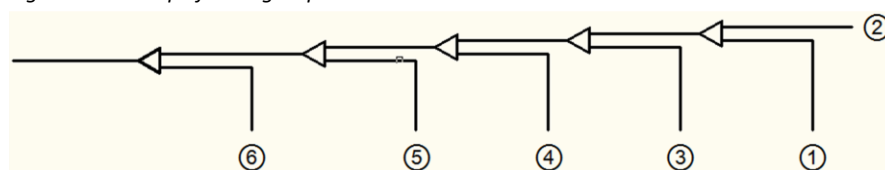

Figure 3-4.15: Pipe flushing sequence¹



Notes:

1. 1-2-3-4-5-6 working towards the outdoor units.

4.9 Gastightness Test

4.9.1 Purpose

To prevent faults caused by refrigerant leakage, a gastightness test should be performed before system commissioning.

4.9.2 Procedure

Notes for installers



Warning

Only dry nitrogen should be used for gastightness testing. Oxygen, air, flammable gases and toxic gases must not be used for gastightness testing. Use of such gases may result in fire or explosion.

Procedure

The gastightness test procedure is as follows:

Step 1

- Once the piping system is complete and the indoor and outdoor units have been connected, vacuum the piping to -0.1MPa.

Step 2

- Charge the indoor piping with nitrogen at 0.3MPa through the needle valves on the liquid and gas stop valves and leave for at least 3 minutes (do not open the liquid or gas stop valves). Observe the pressure gauge to check for large leakages. If there is a large leakage, the pressure gauge will drop quickly.
- If there are no large leakages, charge the piping with nitrogen at 1.5MPa and leave for at least 3 minutes. Observe the pressure gauge to check for small leakages. If there is a small leakage, the pressure gauge will drop distinctly.
- If there are no small leakages, charge the piping with nitrogen at 4.0MPa and leave for at least 24 hours to check for micro leakages. Micro leakages are difficult to detect. To check for micro leakages, allow for any change in ambient temperature over the test period by adjusting the reference pressure by 0.01MPa per 1°C of temperature difference. Adjusted reference pressure = Pressure at pressurization + (temperature at observation – temperature at pressurization) x 0.01MPa. Compare the observed pressure with the adjusted reference pressure. If they are the same, the piping has passed the gastightness test. If the observed pressure is lower than the adjusted reference pressure, the piping has a micro leakage.
- If the leakage is detected, refer to Part 3, 4.9.3 “Leak detection”. Once the leak has been found and fixed, the gastightness test should be repeated.

Step 3

- If not continuing straight to vacuum drying (see Part 3, 4.10 “Vacuum Drying”) once the gastightness test is complete, reduce the system pressure to 0.5-0.8MPa and leave the system pressurized until ready to carry out the vacuum drying procedure.

Figure 3-4.16: Gastightness test

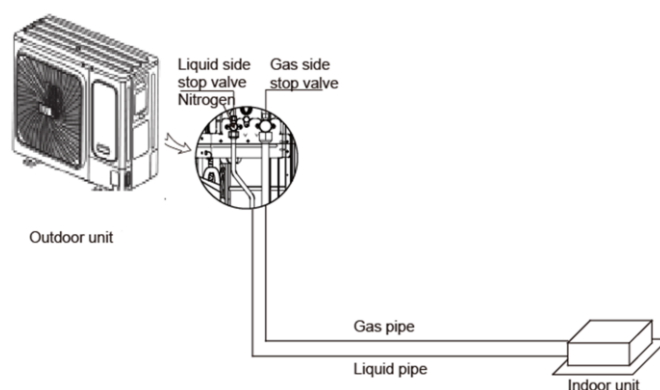

4.9.3 Leak detection

Notes for installers



The general methods for identifying the source of a leak are as follows:

1. Audio detection: relatively large leaks are audible.
2. Touch detection: place your hand at joints to feel for escaping gas.
3. Soapy water detection: small leaks can be detected by the formation of bubbles when soapy water is applied to a joint.
4. Refrigerant leak detection: for leaks that are difficult to detect, refrigerant leak detection may be used as follows:
 - a) Pressurize the piping with nitrogen at 0.3MPa.
 - b) Add refrigerant into the piping until the pressure reaches 0.5MPa.
 - c) Use a halogen refrigerant detector to find the leak.
 - d) If the leak source cannot be found, continuing charging with refrigerant to a pressure of 4MPa and then search again.

4.10 Vacuum Drying

4.10.1 Purpose

Vacuum drying should be performed in order to remove moisture and non-condensable gases from the system. Removing moisture prevents ice formation and oxidization of copper piping or other internal components. The presence of ice particles in the system would cause abnormal operation, whilst particles of oxidized copper can cause compressor damage. The presence of non-condensable gases in the system would lead to pressure fluctuations and poor heat exchange performance.

Vacuum drying also provides additional leak detection (in addition to the gastightness test).

4.10.2 Procedure

Notes for installers



During vacuum drying, a vacuum pump is used to lower the pressure in the piping to the extent that any moisture present evaporates. At 5mmHg (755mmHg below typical atmospheric pressure) the boiling point of water is 0°C. Therefore a vacuum pump capable of maintaining a pressure of -756mmHg or lower should be used. Using a vacuum pump with a discharge in excess of 4L/s and a precision level of 0.02mmHg is recommended.

Caution

- Before performing vacuum drying, make sure that all the outdoor unit stop valves are firmly closed.
- Once the vacuum drying is complete and the vacuum pump is stopped, the low pressure in the piping could suck vacuum pump lubricant into the air conditioning system. The same could happen if the vacuum pump stops unexpectedly during the vacuum drying procedure. Mixing of pump lubricant with compressor oil could cause compressor malfunction and a one-way valve should therefore be used to prevent vacuum pump lubricant seeping into the piping system.

Procedure

The vacuum drying procedure is as follows:

Step 1

- Connect the blue (low pressure side) hose of a pressure gauge to the master unit gas pipe stop valve, the red (high pressure side) hose to the master unit liquid pipe stop valve and the yellow hose to the vacuum pump.

Step 2

- Start the vacuum pump and then open the pressure gauge valves to start vacuum the system.
- After 30 minutes, close the pressure gauge valves.
- After a further 5 to 10 minutes check the pressure gauge. If the gauge has returned to zero, check for leakages in the refrigerant piping.

Step 3

- Re-open the pressure gauge valves and continue vacuum drying for at least 2 hours and until a pressure difference of 756mmHg or more has been achieved. Once the pressure difference of at least 756mmHg has been achieved, continue vacuum drying for 2 hours.

Step 4

- Close the pressure gauge valves and then stop the vacuum pump.
- After 1 hour, check the pressure gauge. If the pressure in the piping has not increased, the procedure is finished. If the pressure has increased, check for leakages.
- After vacuum drying, **keep the blue and red hoses connected to the pressure gauge and to the master unit stop valves**, in preparation for refrigerant charging (see Part 3, 7 “Charging Refrigerant”).

Figure 3-4.17: Vacuum drying

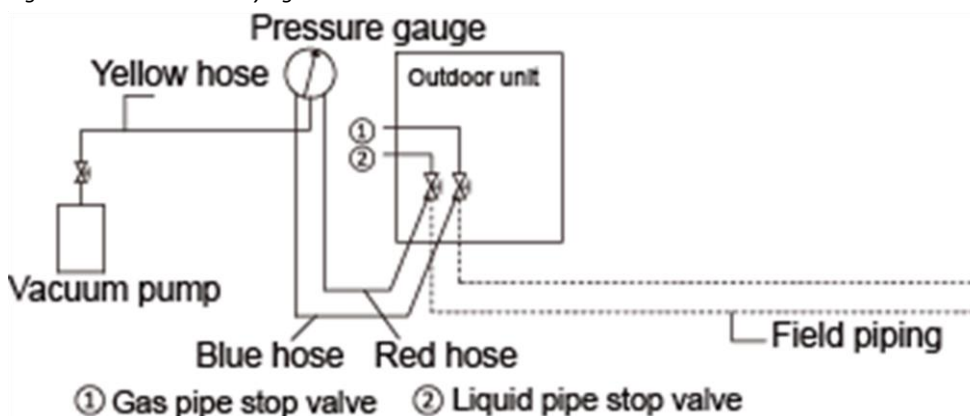

Pressure gauge

5 Drain Piping

5.1 Design Considerations

Drain piping design should take account of the following considerations:

- Indoor unit condensate drain piping needs to be of sufficient diameter to carry the volume of condensate produced at the indoor units and installed at a slope sufficient to allow drainage. Discharge as close as possible to the indoor units is usually preferable.
- To prevent the drain piping becoming excessively long, consideration should be given to installing multiple drain piping systems, with each system having its own drainage point and providing drainage for a subset of the overall set of indoor units.
- The routing of drain piping should take into consideration the need to maintain sufficient slope for drainage whilst avoiding obstacles such as beams and ducting. The drain piping slope should be at least 1:100 away from indoor units. Refer to Figure 3-5.1.

Figure 3-5.1: Drain piping minimum slope requirement

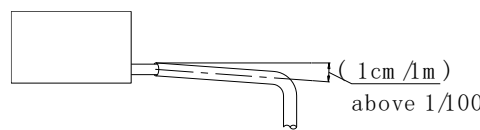

- To avoid backflow and other potential complications, two horizontal drain pipes should not meet at the same level. Refer to the Figure 3-5.2 for suitable connection arrangements. Such arrangements also allow the slope of the two horizontal pipes to be selected independently.

Figure 3-5.2: Drain piping joints – correct and incorrect configurations

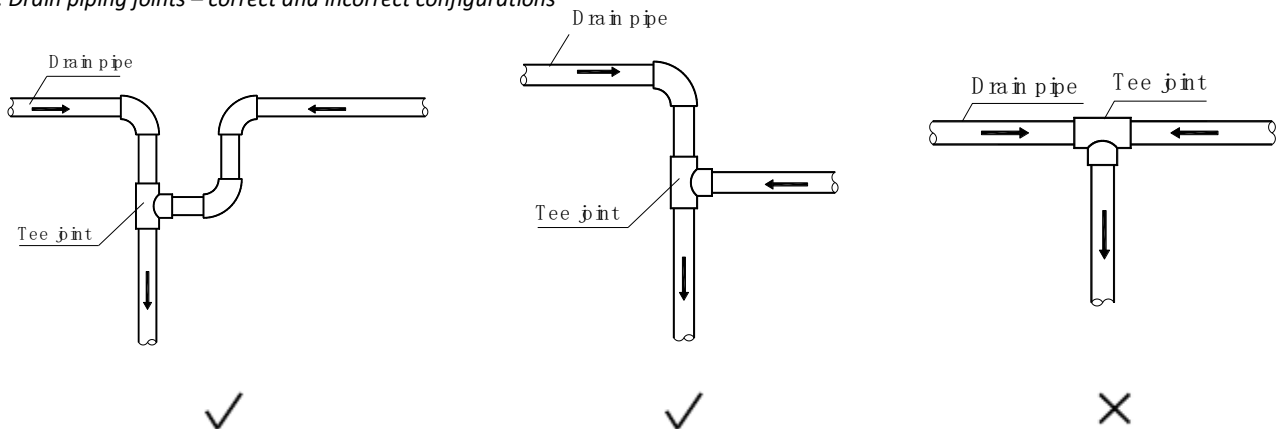

- Branch drain piping should join main drain piping from the top, as shown in Figure 3-5.3.
- Recommended support/hanger spacing is 0.8 – 1.0m for horizontal piping and 1.5 – 2.0m for vertical piping. Each vertical section should be fitted with at least two supports. For horizontal piping, spacing greater than those recommended leads to sagging and deformation of the pipe profile at the supports which impedes water flow and should therefore be avoided.
- Air vents should be fitted at the highest point of each drain piping system to ensure that condensation is discharged smoothly. U-bends or elbow joints should be used such that the vents face downwards, to prevent dust entering the piping. Refer to Figure 3-5.5. Air vents should not be installed too close to indoor unit lift pumps.

Figure 3-5.3: Branch drain piping joining main drain piping

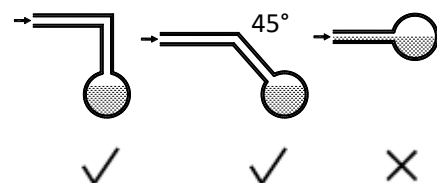

Figure 3-5.4: Effect of insufficient drain piping support

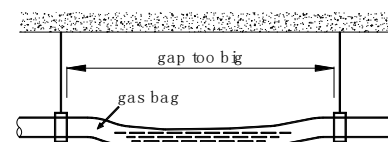
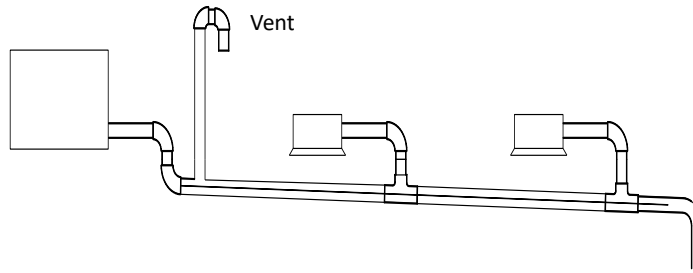

Figure 3-5.5: Drain piping air vents



- Air conditioner drain piping should be installed separately from waste, rainwater and other drain piping and should not come into direct contact with the ground.
- Drain piping diameter should be not less than the indoor units' drain piping connection.
- To allow inspection and maintenance, the piping clamps shipped with units should be used to attach drain piping to indoor units – adhesive should not be used.
- Thermal insulation should be added to drain piping to prevent condensation forming. Thermal insulation should extend all the way to the connection with the indoor unit.
- Units with drain pumps should have separate drain piping systems from systems that use natural drainage.

5.2 Water Traps

For indoor units with a high negative pressure differential at the outlet of the drainage pan, a trap should be fitted to the drain piping to prevent poor drainage and/or water being blown back into the drainage pan. Traps should be arranged as in Figure 3-5.6. The vertical separation H should be in excess of 50mm. A plug may be fitted to allow cleaning or inspection.

Figure 3-5.6: Drain piping water traps

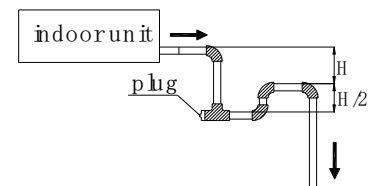

5.3 Selecting Piping Diameters

Select branch drainage piping (the drain piping connection to each unit) diameters according to indoor unit flow volume and select main drainage piping diameters according to the combined flow volume of the upstream indoor units. Use a design assumption of 2 liters of condensate per horsepower per hour. For example, the combined flow volume of three 2HP units and two 1.5HP units would be calculated as follows:

$$\begin{aligned} \text{Combined flow volume} &= 3 \times 2 \text{ L/HP/h} \times 2\text{HP} + 2 \times 2 \text{ L/HP/h} \times 1.5\text{HP} = 18 \text{ L/h} \end{aligned}$$

Tables 3-5.1 and 3-5.2 specify the required piping diameters for horizontal and vertical branch piping and for main piping. Note that main piping should use PVC40 or larger.

Table 3-5.1: Horizontal drain piping diameters

PVC piping	Nominal diameter (mm)	Capacity (L/h)		Remarks
		Slope 1:50	Slope 1:100	
PVC25	25	39	27	Branch piping only
PVC32	32	70	50	
PVC40	40	125	88	Branch or main piping
PVC50	50	247	175	
PVC63	63	473	334	

Table 3-5.2: Vertical drain piping diameters

PVC piping	Nominal diameter (mm)	Capacity (L/h)	Remarks
PVC25	25	220	Branch piping only
PVC32	32	410	
PVC40	40	730	Branch or main piping
PVC50	50	1440	
PVC63	63	2760	
PVC75	75	5710	
PVC90	90	8280	

5.4 Drain Piping for Units with Lift Pumps

Drain piping for units with lift pumps should take account of the following additional considerations:

- A downward sloping section should immediately follow the vertically rising section adjacent to the unit, otherwise a water pump error will occur. Refer to Figure 3-5.7.
- Air vents should not be installed on vertically rising sections of drain piping, otherwise water may be discharged through the air vent or water flow may be impeded.

Figure 3-5.7: Downward sloping section of drain piping

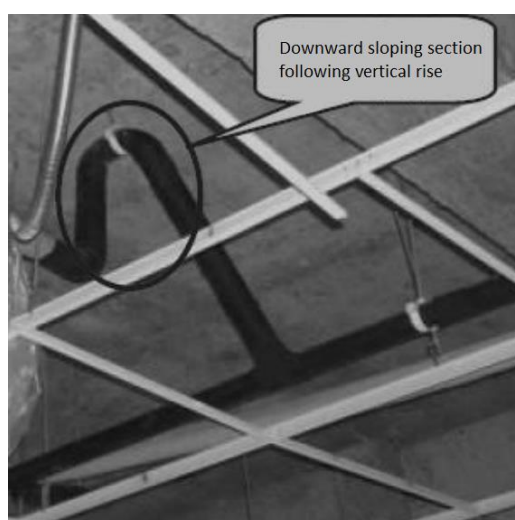

5.5 Drain Piping Installation

Notes for installers



Installation of the drain piping should proceed in the following order:

Indoor unit installation

Drain piping installation

Watertightness test

Drain piping insulation

Caution

- Ensure that all joints are firm and once the drain piping is all connected conduct a watertightness test and water flow test.
- Do not connect air conditioner drain piping to waste, rainwater or other drain piping and do not let air conditioner drain piping come into direct contact with the ground.
- For units with drain pumps, test that the drain pump functions properly by adding water to the unit's drainage pan and running the unit. To allow inspection and maintenance, the pipe clamps shipped with units should be used to attach drain piping to indoor units – adhesive should not be used.

5.6 Watertightness Test and Water Flow Test

Once installation of a drainage piping system is complete, watertightness and water flow tests should be performed.

Notes for installers



Watertightness test

- Fill the piping with water and test for leakages over a 24-hour period.

Water flow test (natural drainage test)

- Slowly fill the drainage pan of each indoor unit with at least 600ml of water through the inspection port and check that the water is discharged through the outlet of the drain piping.

Caution

- The drain plug in the drainage pan is for removing accumulated water prior to performing indoor unit maintenance. During normal operation, the drain should be plugged to prevent leakage.

6 Insulation

6.1 Refrigerant Piping Insulation

6.1.1 Purpose

During operation, the temperature of the refrigerant piping varies. Insulation is required to ensure unit performance and compressor lifespan. During cooling, the gas pipe temperature can be very low. Insulation prevents condensation forming on the piping. During heating, the gas pipe temperature can rise to as high as 100°C. Insulation serves as necessary protection from burns.

6.1.2 Selecting insulation materials

Refrigerant piping insulation should be closed-cell foam of B1 fire resistance rating that can withstand a constant temperature of over 120°C and that complies with all applicable legislation.

6.1.3 Thickness of insulation

Minimum thicknesses for refrigerant piping insulation are specified in Table 3-6.1. In hot, humid environments, the thickness of insulation should be increased over and above the specifications in Table 3-6.1.

Table 3-6.1: Refrigerant piping insulation thickness

Pipe outer diameter (mm)	Minimum insulation thickness (mm)
Φ6.35	15
Φ9.52	
Φ12.7	
Φ15.9	20
Φ19.1	
Φ22.2	
Φ25.4	
Φ28.6	

6.1.4 Installation of piping insulation

With the exception of joint insulation, insulation should be applied to piping before fixing the piping in place. Insulation at joints in refrigerant piping should be applied after the gastightness test has been completed.

Notes for installers



- Installation of insulation should be carried out in a manner suited to the type of insulation material being used.
- Ensure there are no gaps at the joints between sections of insulation.
- Do not apply tape too tightly as doing so may shrink insulation, reducing its insulating properties leading to condensation and loss of efficiency.
- Insulate gas and liquid pipes separately, otherwise heat exchange between the two sides will greatly impact efficiency.
- Do not bind the separately insulated gas and liquid pipes together too tightly as doing so can damage the joints between sections of insulation.

6.1.5 Installation of joint insulation

Insulation at joints in the refrigerant piping should be installed after the gastightness test has been successfully completed. The procedure at each joint is as follows:

1. Cut a section of insulation 50 to 100mm longer than the gap to be filled. Ensure that the cross-sectional and longitudinal openings are all cut evenly.
2. Embed the section into the gap ensuring that the ends abut tightly to the sections of insulation either side of the gap.
3. Glue the longitudinal cut and the joints with the sections of insulation either side of the gap.
4. Seal the seams with tape.

Figure 3-6.1: Installation of joint insulation (unit: mm)

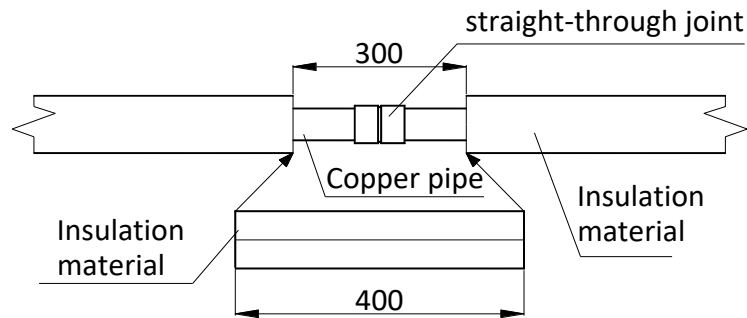

6.2 Drain Piping Insulation

- Use rubber/plastic insulating tube with a B1 fire resistance rating.
- The insulation should typically be in excess of 10mm thick.
- For drain piping installed inside a wall, insulation is not required.
- Use suitable adhesive to seal seams and joints in the insulation and then bind with cloth reinforced tape of width not less than 50mm. Ensure tape is fixed firmly to avoid condensation.
- Ensure the drain piping insulation adjacent to the indoor unit drainage water outlet is fixed to the unit itself using adhesive, to prevent condensation and dripping.

6.3 Ducting Insulation

- Suitable insulation should be added to ducting in according with all applicable legislation.

7 Charging Refrigerant

7.1 Calculating Additional Refrigerant Charge

Calculate the additional charge amount of total refrigerant **R(kg)** according to the following formula:

$$R \text{ (kg)} = R1 - 0.1 \times N$$

R1 is the additional refrigerant charge quantity for liquid piping

N is the number of Slim Duct indoor units whose height is 199mm.

7.1.1 Calculating the additional refrigerant charge calculation for liquid piping (R1 kg)

The additional refrigerant charge calculation for liquid piping depends on the lengths and diameters of the outdoor and indoor liquid pipes. Table 3-7.1 shows the additional refrigerant charge required per meter of equivalent pipe length for different diameters of pipe. The total additional refrigerant charge is obtained by summing the additional charge requirements for each of the outdoor and indoor liquid pipes, as in the following formula, where L_1 to L_8 represent the equivalent lengths of the pipes of different diameters. Assume 0.5m for the equivalent pipe length of each branch joint.

$$\begin{aligned} \text{Additional refrigerant charge } R1 \text{ (kg)} &= L_1 (\Phi 6.35) \times 0.022 \\ &+ L_2 (\Phi 9.52) \times 0.057 \\ &+ L_3 (\Phi 12.7) \times 0.110 \\ &+ L_4 (\Phi 15.9) \times 0.170 \end{aligned}$$

Table 3-7.1: Additional refrigerant charge

Liquid side piping (mm)	Additional refrigerant charge per meter of equivalent length of piping (kg)
Φ6.35	0.022
Φ9.52	0.057
Φ12.7	0.110
Φ15.9	0.170

7.1.2 Maximum refrigerant quantity limit of the system

The refrigerant quantity of system $R_s(\text{kg}) = R0 + R$

R0 is factory refrigerant charge quantity

R is additional charge quantity amount of total refrigerant

Table 3-7.2: Factory refrigerant charge quantity R0 (unit: kg)

Model	80	100	120	140	160
R0(kg)	3.1	3.1	4.1	4.1	4.1

The maximum refrigerant quantity (R_s) limit of the system is **14kg**

7.2 Adding Refrigerant

Notes for installers



Caution

- Only charge refrigerant after performing a gastightness test and vacuum drying.
- Never charge more refrigerant than required as doing so can lead to liquid hammering.
- Only use refrigerant R410A - charging with an unsuitable substance may cause explosions or accidents.
- Use tools and equipment designed for use with R410A to ensure required pressure resistance and to prevent foreign materials from entering the system.
- Refrigerant must be treated in accordance with applicable legislation.
- Always use protective gloves and protect your eyes when charging refrigerant.
- Open refrigerant containers slowly.
- The power supply for all outdoor units should be turned on, when add refrigerant.

Procedure

The procedure for adding refrigerant is as follows:

Step 1

- Calculate additional refrigerant charge R (kg) (see Part 3, 7.1 “Calculating Additional Refrigerant Charge”)

Step 2

- Place a tank of R410A refrigerant on a weighing scale. Turn the tank upside down to ensure refrigerant is charged in a liquid state. (R410A is a blend of two different chemicals compounds. Charging gaseous R410A into the system could mean that the refrigerant charged is not of the correct composition).
- After vacuum drying (see Part 3, 4.10 “Vacuum Drying”), the blue and red pressure gauge hoses should still be connected to the pressure gauge and to the master unit stop valves.
- Connect the yellow hose from the pressure gauge to the R410A refrigerant tank.

Step 3

- Open the valve where the yellow hose meets the pressure gauge, and open the refrigerant tank slightly to let the refrigerant eliminate the air. Caution: open the tank slowly to avoid freezing your hand.
- Set the weighing scale to zero.

Step 4

- Open the three valves on the pressure gauge to begin charging refrigerant.
- When the amount charged reaches R (kg), close the three valves. If the amount charged has not reached R (kg) but no additional refrigerant can be charged, close the three valves on the pressure gauge, run the outdoor units in cooling mode, and then open the yellow and blue valves. Continue charging until the full R (kg) of refrigerant has been charged, then close the yellow and blue valves. Note: Before running the system, be sure to complete all the pre-commissioning checks as listed in Part 3 “Pre-commissioning Checks” and be sure to open all stop valves as running the system with the stop valves closed would damage the compressor.

Figure 3-7.1: Charging refrigerant

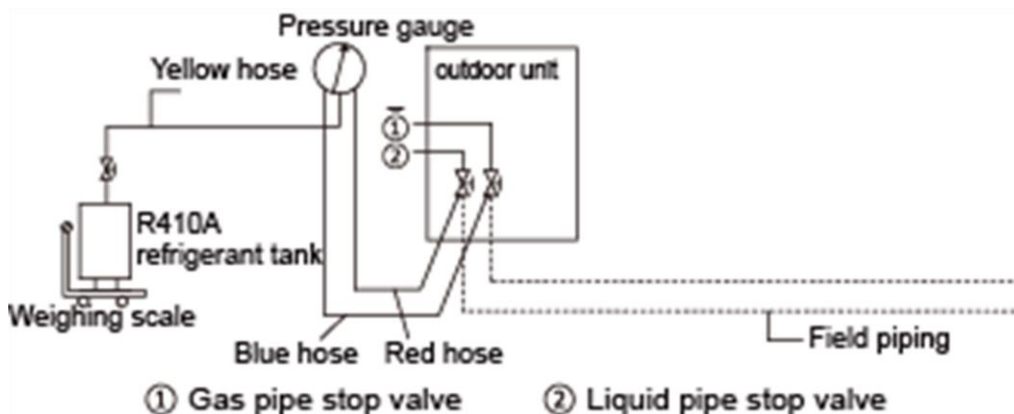

Pressure gauge

8 Electrical Wiring

8.1 General

Notes for installers



Caution

- All installation and wiring must be carried out by competent and suitably qualified, certified and accredited professionals and in accordance with all applicable legislation.
- Use only wires with copper cores for the connections.
- Wiring must be carried out in strict accordance with what is stated in the product nameplate.
- Electrical systems should be grounded in accordance with all applicable legislation. Do not connect the earth wire to public pipes, telephone earth wires, surge absorbers and other places that are not designed for grounding. Improper grounding may cause electric shock.
- Overcurrent circuit breakers and residual-current circuit breakers (ground fault circuit interrupters) should be used in accordance with all applicable legislation.
- Wiring patterns shown in this data book are general connection guides only and are not intended for, or to include all details for, any specific installation.
- The refrigerant piping, power wiring and communication wiring are typically run in parallel. However, if EasyCom communication is not activated, the communication wiring should not be bound together with the refrigerant piping or power wiring. To prevent signal interference, the power wiring and communication wiring should not be run in the same conduit. If the power supply is less than 10A, a separation of at least 300mm between power wiring and communication wiring conduits should be maintained; if the power supply is in the range 10A to 50A then a separation of at least 500mm should be maintained.

8.2 Power Supply Wiring

Power supply wiring design and installation should adhere to the following requirements:

- Separate power supplies should be provided for the indoor units and outdoor units.
- Where five or more outdoor units are installed, additional residual current protection (leakage protection) should be installed.
- All the indoor units in a system (i.e. all the indoor units connected to the same set of outdoor units) should be tied into the same power circuit with the same power supply, overcurrent and residual current protection (leakage protection) and manual switch, as shown in Figure 3-8.1. Do not install separate protectors or manual switches for each indoor unit. Powering on and shutting down all indoor units in a system should be done simultaneously. The reason for this is that if an indoor unit that is running were to suddenly power off whilst the other indoor units continued running, the evaporator of the powered-off unit would freeze since refrigerant would continue flowing to that unit (its expansion valve would still be open) but its fan would have stopped. The indoor units that remain running would not get sufficient refrigerant so their performance would suffer. Additionally, liquid refrigerant returning directly to the compressor from the powered-off unit would cause liquid hammering, potentially damaging the compressor.
- Indoor units can be powered separate when EasyCom communication is activated, refer to Part3, 8.3.4 “M1 M2 communication”.
- For outdoor unit power wire sizing and circuit breaker sizing, refer to Table 2-6.1 in Part 2, 6 “Electrical Characteristics”.

Figure 3-8.1: Indoor unit unified power supply wiring
Single-phase 220~ 50/60Hz

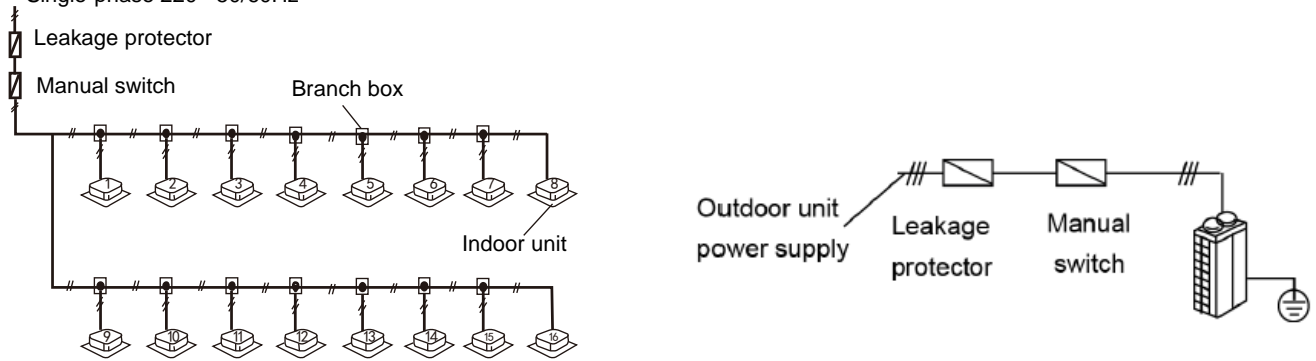

Notes for installers



The 220-240V, ~, 50Hz power supply should be connected to the outdoor unit power supply terminals as shown in Figure 3-8.2. Use round-type terminals of the correct specifications to connect the power cable.

Figure 3-8.2: Outdoor unit 1-phase power supply terminals

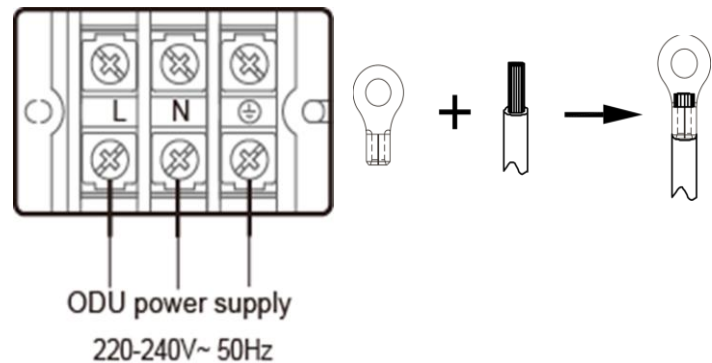

The 380-415V, 3N~, 50Hz power supply should be connected to the outdoor unit power supply terminals as shown in Figure 3-8.3. Use round-type terminals of the correct specifications to connect the power cable.

Figure 3-8.3: Outdoor unit 3-phase power supply terminals

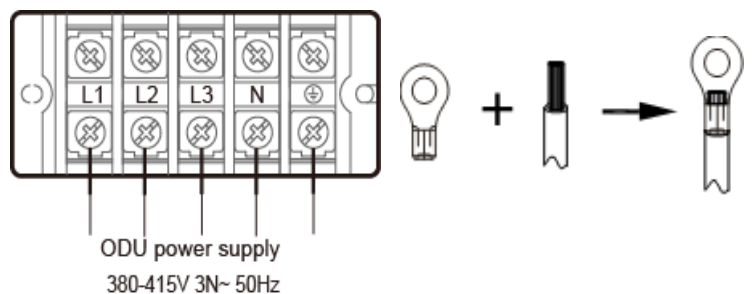

8.3 Communication Wiring

Communication wiring design and installation should adhere to the following requirements:

- Do not connect the communication line when the power is on.
- Connect the shielding nets at both ends of the shielded wire to the sheet metal “ ” of the electronic control box.
- Do not connect the power cable to the terminal of communication line, otherwise, the motherboard will be damaged.
- Do not connect a system with both EasyCom (M1 M2) communication lines and P Q communication lines.
- On-site wiring must comply with the relevant regulations of the local Country/region and must be completed by professionals.
- The communication lines of the indoor and ODU can only be connected from the outdoor unit.
- When a single communication line is not long enough, the joint must be crimped or soldered, and the copper wire at the joint shall not be exposed.
- When use EasyCom, It is forbidden to reverse the connection of the two communication ports (to up IDU) and (to down IDU) of the repeater.
- V8 Mini outdoor unit compatible with different generation indoor units, the communication connection type should follow table 3-8.1.

Table 3-8.1: Communication connection between ODU and IDUs

Indoor unit generation	Communication connection type	Wire diameter (mm ²)	Length limitation (m)
All V8 indoor units and unified power supply	M1 M2 / P Q	2x0.75	2000 / 1200
All V8 indoor units and separate power supply	M1 M2	2x1.5	400 (1 repeaters are required)
Once there is 2 nd generation indoor unit in the system	P Q E	3x0.75	1200

Figure 3-8.3: Example of indoor unit and outdoor unit communication line connection

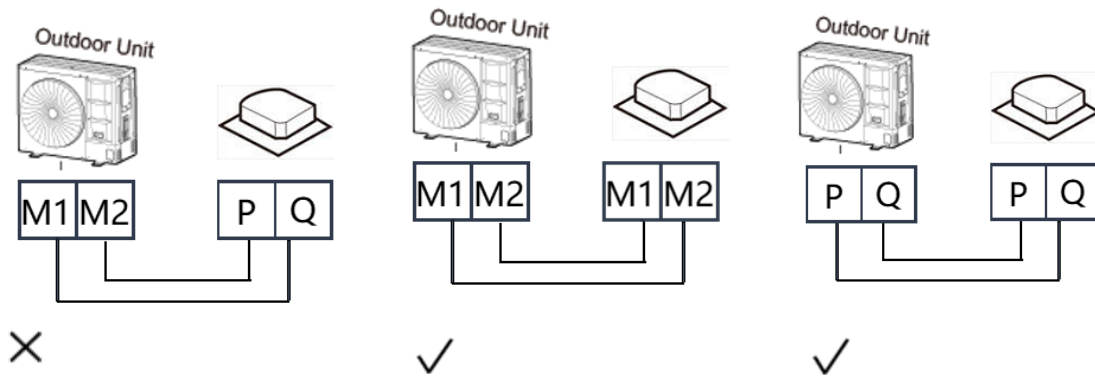

Notes for installers



The communication wires should be connected to the master outdoor unit terminals indicated in Figure 3-8.4 and Table 3-8.2.

Caution

- Communication wiring has polarity. Care should be taken to connect the poles correctly.

Figure 3-8.4: Master outdoor unit communication terminals

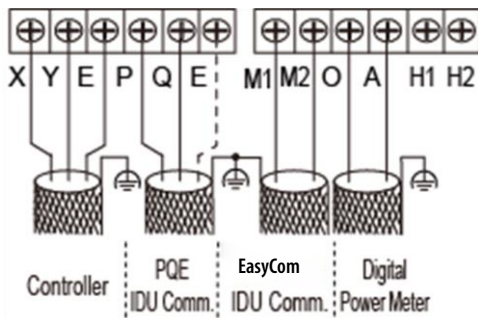

Table 3-8.2: Communication connections

Terminals	Connection
X Y E	Connect to centralized controller
P Q E	Communication connection between indoor units and outdoor unit
M1 M2	EasyCom communication connection between indoor units and outdoor unit
O A	Connect to digital energy meter
H1 H2	Reserved

8.3.1 The magnetic ring installation

For the system, the EMI effect of the communication line PQE can be improved by adding a magnetic ring. The magnetic ring needs to be fixed with the communication line (it can be wound for two turns), and placed in the electric control box and secured with a wire clamp.

8.3.1 Outdoor unit and indoor units' P Q E communication

Communication wiring design and installation should adhere to the following requirements:

- 0.75mm² three-core shielded cable should be used for communication wiring. Using other types of cable can lead to interference and malfunction.
- Do not bind the communication line, refrigerant piping and power cable together.
- When the power cable and communication line are laid in parallel, the distance between the two lines must be 5cm or more to prevent signal source interference.
- The P Q E communication wires should be connected one unit after another in a daisy chain from the outdoor unit to the final indoor unit as shown in Figure 3-8.5. At the final indoor unit, a 120Ω resistor should be connected between the P and Q terminals. After the final indoor unit, the communication wiring should NOT be continued back to the outdoor unit – that is, do not attempt to form a closed loop.
- The P and Q communication wires should NOT be connecting to E.
- The shielding nets of the communication wires should be connected together and grounded. Grounding can be achieved by connecting to the metal casing adjacent to the P Q E terminals of the outdoor unit electrical control box.
- All IDUs in a system must be powered through a uniform power supply so that they can be powered on or off at the same time.
- The communication wiring (P, Q, E) must through the magnetic ring from the main board to the IDUs.
- Applicable standards: EN 55014-1 and EN 55014-2. The communication line must be shielded wire.

Figure 3-8.5: P Q E communication wiring configuration – IDUs uniform power supplied

- RS-485(P Q E) communication

$L1+La+Ln \leq 1200m$, Communication wiring $3 \times 0.75mm^2$

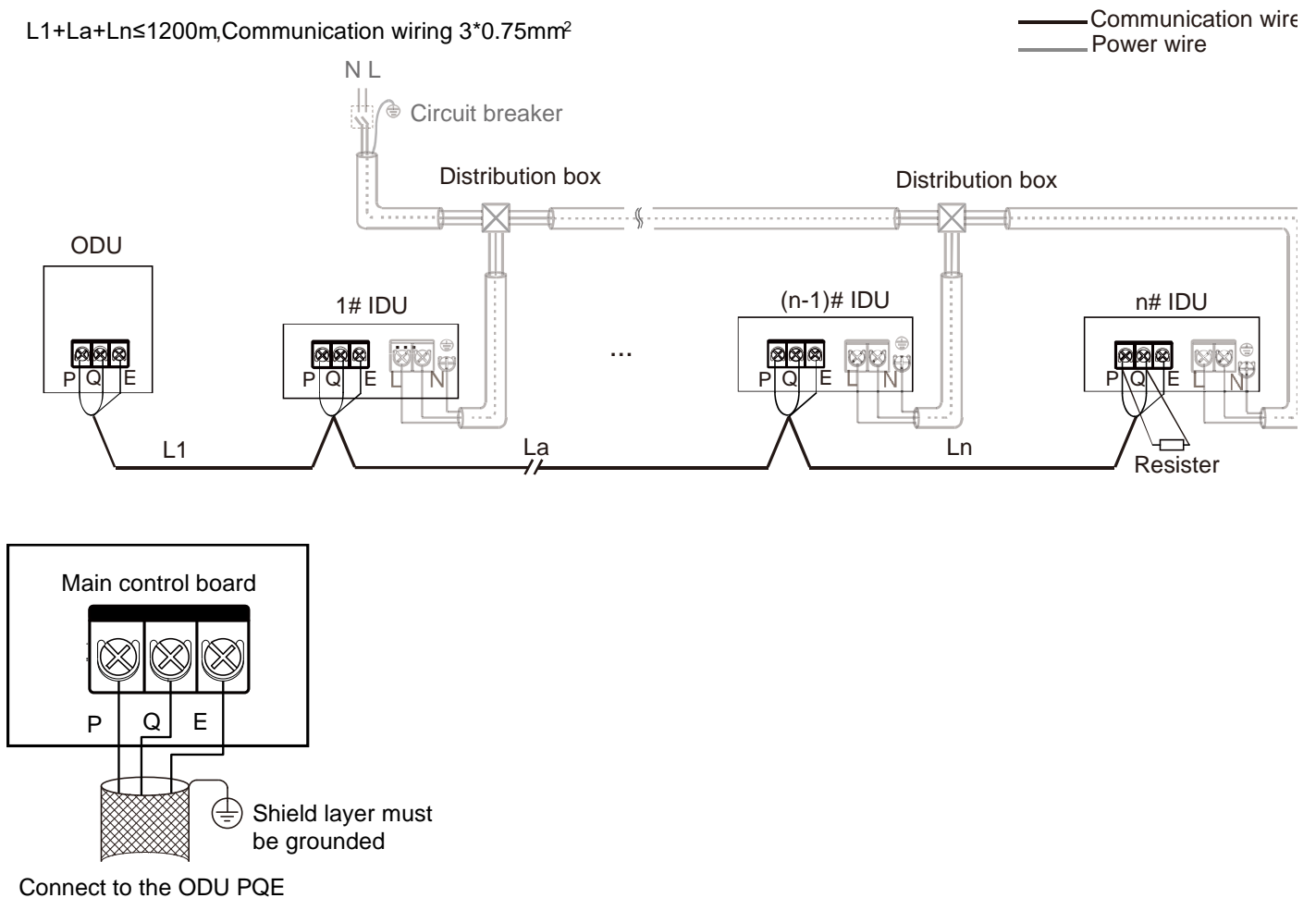

8.3.3 Outdoor unit and indoor units' M1, M2 communication-IDUs uniform power supplied

Communication wiring design and installation should adhere to the following requirements **when all IDUs uniform power supplied**:

- 0.75mm² two-core shielded cable should be used for communication wiring when all the indoor units are uniform power supplied.
- All indoor units in the system are V8 indoor units.
- After the final indoor unit, the communication wiring CAN be continued back to the outdoor unit to ensure communication in case of disconnection point. In this situation M1 M2 are polarized and M1 should connect to M1, M2 should connect to M2. If wrongly connected the PCB may be damaged.
- Applicable standards: EN 55014-1 and EN 55014-2. The communication line must be shielded wire.

Figure 3-8.7: M1 M2 communication wiring configuration – IDUs uniform power supplied

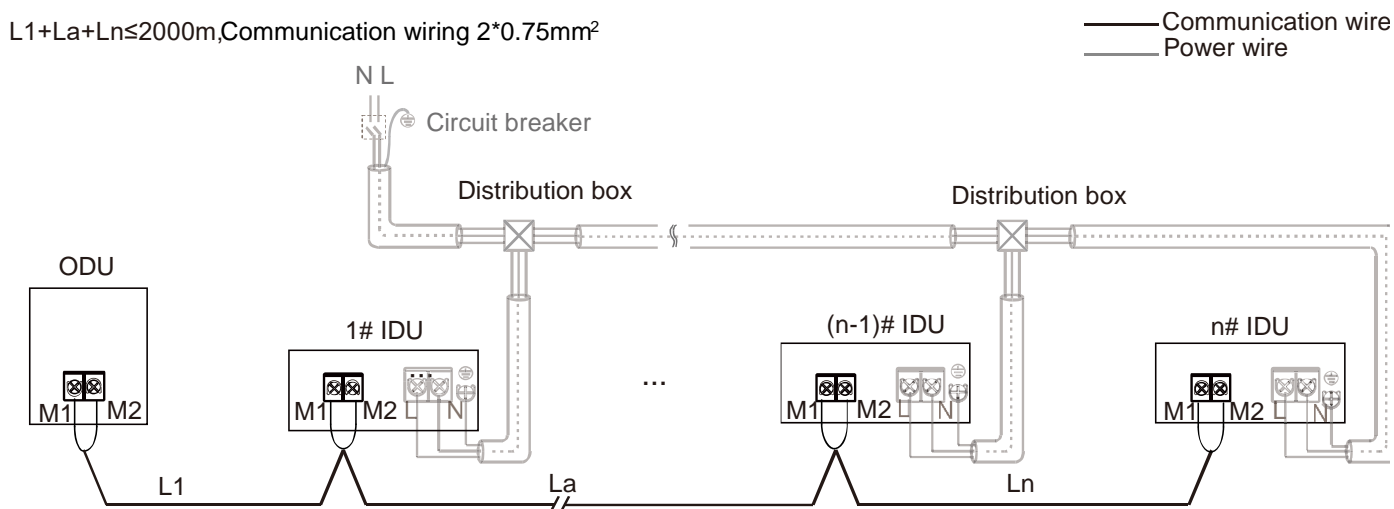

8.3.4 Outdoor unit and indoor units' M1, M2 communication- IDUs with separate power supply

Communication wiring design and installation should adhere to the following requirements **when IDUs separate power supplied**.

- 1.5mm² two-core shielded cable should be used for communication wiring when there is indoor unit separate power supplied.
- All indoor units in the system are V8 indoor units.
- If the total distance is less than or equal to 200m and the total number of IDUs is less than or equal to 10 sets, the valve is powered and controlled by the master ODU.
- If the total distance is longer than 200m or the total number of IDUs is more than 10 sets, a repeater is required to increase the bus voltage. The load capacity of the repeater is the same as that of the ODU, and it can load a bus length of 200m or 10 IDUs.
- Maximum one repeater can be installed in the same refrigerant system.
- The number of IDUs requiring power supply in the same refrigerant system is less than or equal to 11 sets.
- Keep the power on/off for both the repeater and the ODUs, or the repeater use an uninterruptible power supply.
- For repeater installation, please refer to the repeater installation manual. Do not reversely connect the upstream and downstream IDU ports of the repeater; otherwise, it will cause a communication failure
- After the final indoor unit, the communication wiring CAN be continued back to the outdoor unit to ensure communication in case of disconnection point. Max number of IDUs connected is 10. In this situation M1 M2 are polarized and M1 should connect to M1, M2 should connect to M2. If wrongly connected the PCB may be damaged.
- Applicable standards: EN 55014-1 and EN 55014-2. The communication line must be shielded wire.

Figure 3-8.8: M1 M2 communication wiring configuration – IDUs separate power supplied

$L1+La+Lx \leq 200m$, $L1 \leq 200mm$. Communication wiring $2 \times 1.5mm^2$

— Communication wire
 — Power wire

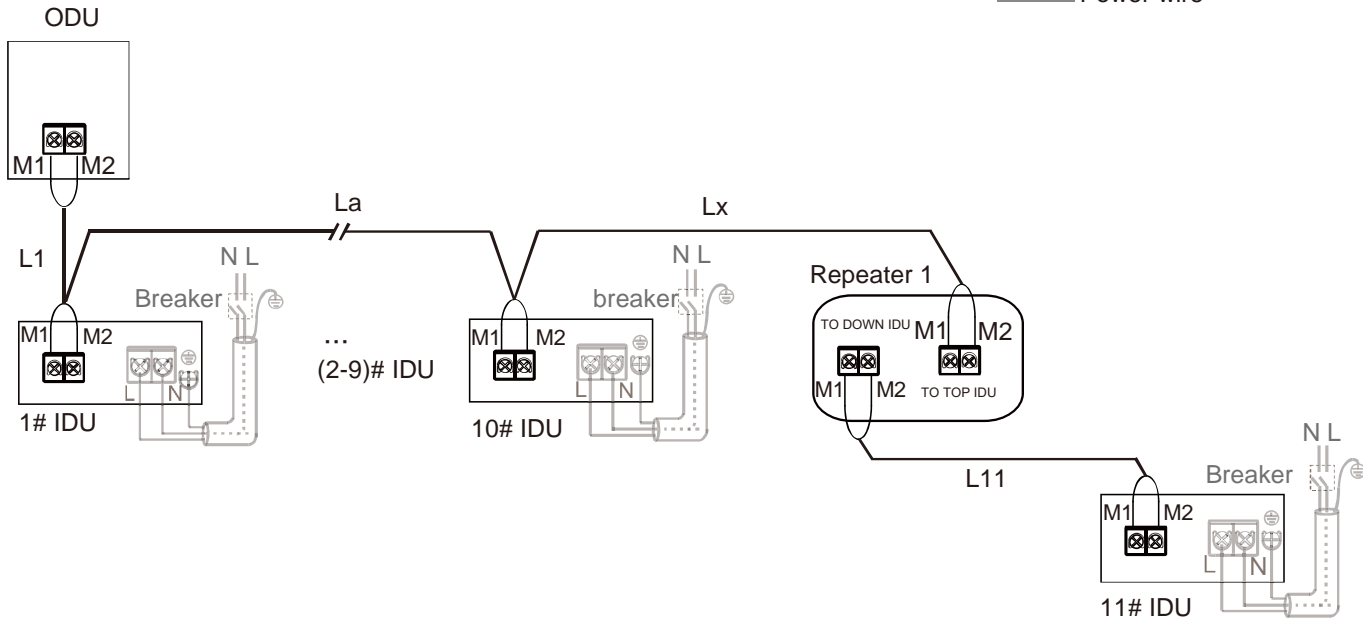

8.3.5 System X Y E and O A communication

- The cross-sectional area of each core of the communication wiring is not less than 0.75 mm², and the length must not exceed 1200 m.
- The centralized controller and digital electric meter are optional accessories. Please contact the local dealer for purchase if needed.
- Connect the shielding nets at both ends of the shielded wire to the sheet metal “ \oplus ” of the electronic control box.
- Applicable standards: EN 55014-1 and EN 55014-2. The communication line must be shielded wire.

Figure 3-8.9: X Y E and O A communication wiring configuration

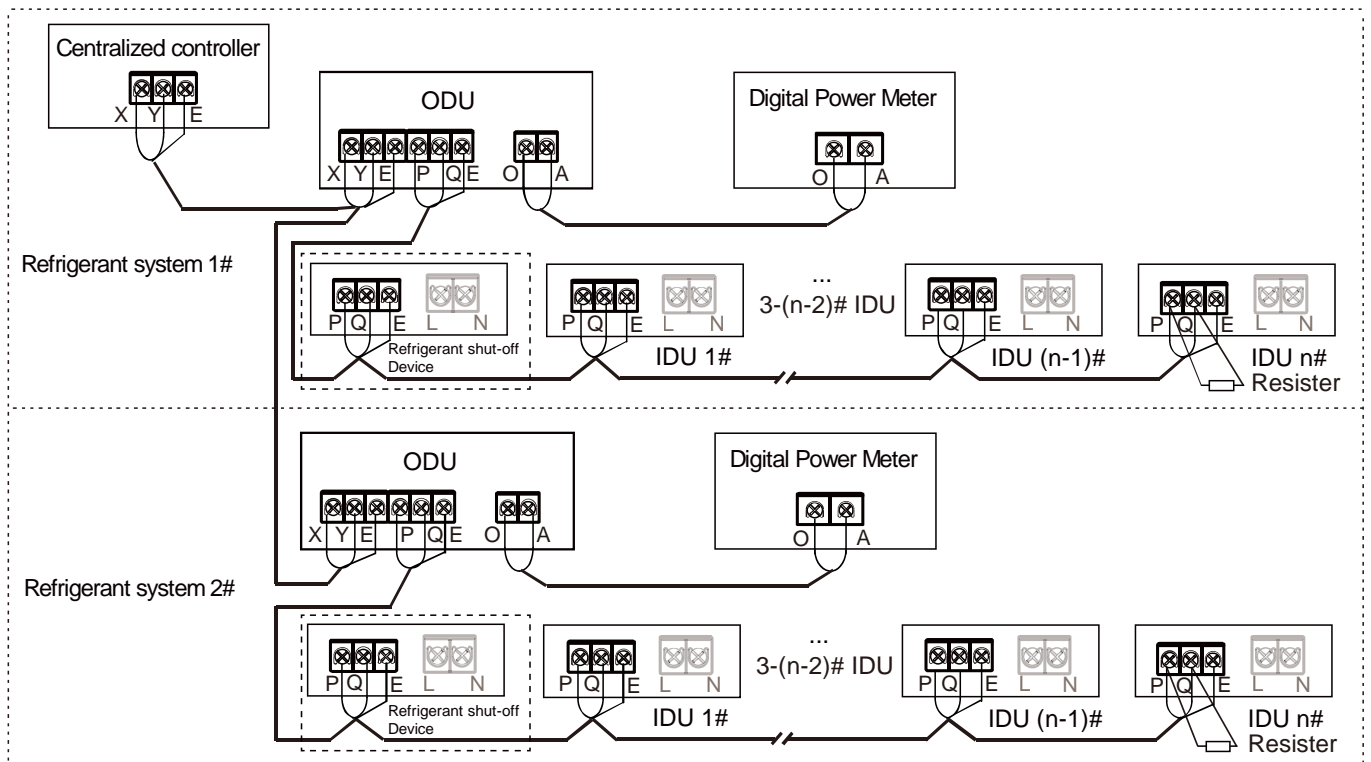

9 Installation in Areas of High Salinity

9.1 Caution

Do not install outdoor units where they could be directly exposed to sea air. Corrosion, particularly on the condenser and evaporator fins, could cause product malfunction or inefficient performance.

Outdoor units installed in seaside locations should be placed such as to avoid direct exposure to the sea air and additional anticorrosion treatment options should be selected, otherwise the service life of the outdoor units will be seriously affected.

Air conditioning installed in seaside locations should be run regularly as the running of the outdoor unit fans helps prevent build-up of salt on the outdoor unit heat exchangers.

9.2 Placement and Installation

Outdoor units should be installed 300m or more from the sea. If possible, well-ventilated indoor locations should be chosen. If it is necessary to install outdoor units outside, direct exposure to the sea air should be avoided. A canopy should be added to shield the units from sea air and rain.

Ensure that base structures drain well so that outdoor unit footings do not become waterlogged. Check that outdoor unit casing drainage holes are not blocked.

9.3 Inspection and maintenance

In addition to standard outdoor unit servicing and maintenance, the following additional inspections and maintenance should be undertaken for outdoor units installed in seaside locations:

- A comprehensive post-installation inspection should check for any scratches or other damage to painted surfaces and any damaged areas should be repainted/repaired immediately.
- The units should be regularly cleaned using (non-salty) water to remove any salt that has accumulated. Areas cleaned should include the condenser, the refrigerant piping system, the outside surface of the unit casing and the outside surface of the electric control box.
- Regular inspections should check for corrosion and if necessary corroded components should be replaced and/or anti-corrosion treatments should be added.

10 Commissioning

10.1 Pre-commissioning Checks

Before turning on the power to the indoor and outdoor units, ensure the following:

- **Installation**

Check if the unit is installed correctly to prevent strange noises and vibrations when the unit starts.

- **Field wiring**

Based on the wiring schematic and the relevant regulations, make sure the field wiring is based on the instructions described in Part 3, "8" Electrical Wiring" on connecting wires.

- **Earth line**

Make sure the earth line is connected correctly, and the grounding terminal is tight.

- **Insulation test of main circuit**

Use the multimeter of 500V, apply a voltage of 500V DC between the power terminal and the earth terminal. Check that the insulation resistance is above 2 MΩ. Do not use the multimeter on the transmission line.

- **Fuses, circuit breakers, or protection devices**

Check that the fuses, circuit breakers, or locally installed protection devices comply with the size and type specified in Part 2, "7 Functional Components and Safety Devices". Make sure you use fuses and protection devices.

- **Internal wiring**

Visually inspect if the connections between the electrical component box and the interior of the unit is loose, or if the electrical components are damaged.

- **Piping dimensions and insulation**

Make sure the installation piping dimensions are correct, and the insulation work can be carried out normally.

- **Stop valve**

Make sure the stop valve is open on both the liquid, low pressure and high pressure gas sides.

- **Equipment damage**

Check for damaged components and extruded piping inside the unit.

- **Refrigerant leak**

Check for refrigerant leaks inside the unit. If there is a refrigerant leak, try to repair the leak. If the repair is not successful, please call the local agent. Do not come in contact with the refrigerant leaking from the refrigerant piping connections. It may cause frostbite.

- **Oil leak**

Check if there is oil leaking from the compressor. If there is an oil leak, try to repair the leak. If the repair is not successful, please call the local agent.

- **Air inlet/outlet**

Check for paper, cardboard or any other material that may obstruct the air inlet and outlet of the equipment.

- **Add additional refrigerant**

The amount of refrigerant to be added to this unit should be marked on the "Confirmation Table" which is placed at electrical control box front cover.

- **Installation date and field settings**

Make sure the installation date is recorded on the label of the electric control box cover, and the field settings are recorded as well.

10.2 Outdoor Unit Address and Communication Type Setting

Step 1: Power on

Cover the lower panel of the ODU, and power on all IDUs and ODUs.

Step 2: Enter commissioning mode

When the ODU is first powered on, it displays "-. -. -. .-", which means the unit is not commissioned. Long press the "DOWN" and "UP" buttons simultaneously for 5s on the master ODU to enter commissioning mode.

Step 3: Set the number of IDUs in a system

The digital display of the master ODU displays "01 01", where 1st and 2nd digits always on, 3rd and 4th digits flashing. The 3rd and 4th digits represent the number of IDUs, the initial value is 1, short press the "DOWN" or "UP" button to change the number. Once the number of IDUs has been set, short press the "OK" button to confirm and automatically proceed to the next step.

Step 4: Select the system communication protocol

Enter the communication protocol setting interface, the digital display of master ODU displays "02 0", where the 1st and 2nd digits always on, the 3rd digit off, the 4th digit flashing. The 4th digit of the digital display represents the communication protocol type, the initial value is 0. Short press the "DOWN" or "UP" button to change the communication protocol.

If the system is **all V8 IDUs**, and the IDUs and ODUs are connected by **PQ** communication, please select V8 protocol RS-485 (P Q) communication, and set the 4th digit of the master ODU digital display to **0**; ODU factory default V8 protocol RS-485 (P Q) communication.

If the system has a **non-V8 IDUs**, and the IDUs and ODUs are connected by **PQE** communication, please select the non-V8 protocol RS-485 (P Q E) communication and set the 4th digit of the master ODU digital display to **1**.

If the system is **all V8 IDUs**, the IDUS and ODUs are connected by **M1M2** communication, and all IDUs are powered uniformly, please select the EasyCom(M1M2) communication + **indoor unit uniform power supply**, and set the 4th digit of the master ODU digital display to **2**.

If the system is **all V8 IDUs**, the IDUS and ODUs are connected by **M1M2** communication, and there is separate power supply for IDUS, please select the EasyCom (M1M2) communication + **indoor unit separate power supply**, and set the 4th digit of the master ODU digital display to **3**.

Once the communication protocol has been set, short press the "OK" button to confirm and automatically proceed to the next step.

Step 5: IDUs and ODUs address setting

Enter the auto addressing function, the digital display of master ODU flashes "AU Ad" and "X YZ" in rotation. "AU Ad" means the auto addressing is in progress, "X" represents the address of the ODU, "YZ" represents the number of detected IDUs; the auto addressing takes about 5-7 minutes, and automatically proceed to the next step after completion.

Step 6: System initialization

Entering system initialization, the digital display of master ODU flashes "AU Ad" and "X YZ" in rotation. "INIt" means initialization is in progress, "X" represents the address of the ODU, "YZ" represents the number of detected IDUs; the system initialization takes about 3-5 minutes, and automatically proceed to the next step after completion.

Step 7: End

After system initialization, if there is no fault in the system, all ODUs will enter standby mode and the digital display will display "X YZ" ("X" represents the address of the ODUs, "YZ" represents the number of detected IDUs), and the unit can be turned on normally.

After system initialization, if the ODU detects a fault, the digital display of master ODU will display "X YZ" ("X" represents the address of the ODU, "YZ" represents the number of detected IDUs) and the error code in rotation. Please refer to the Error Code Table for troubleshooting, and the unit can be turned on normally after the fault is cleared.

Step 8: Other settings

After completing the test run, you can set the relevant functions of the unit according to the actual functional requirements. For specific operations, please refer to related technical documents. If there is no special requirement, you can skip this step.

Figure 3-10.1: Test Run Procedure

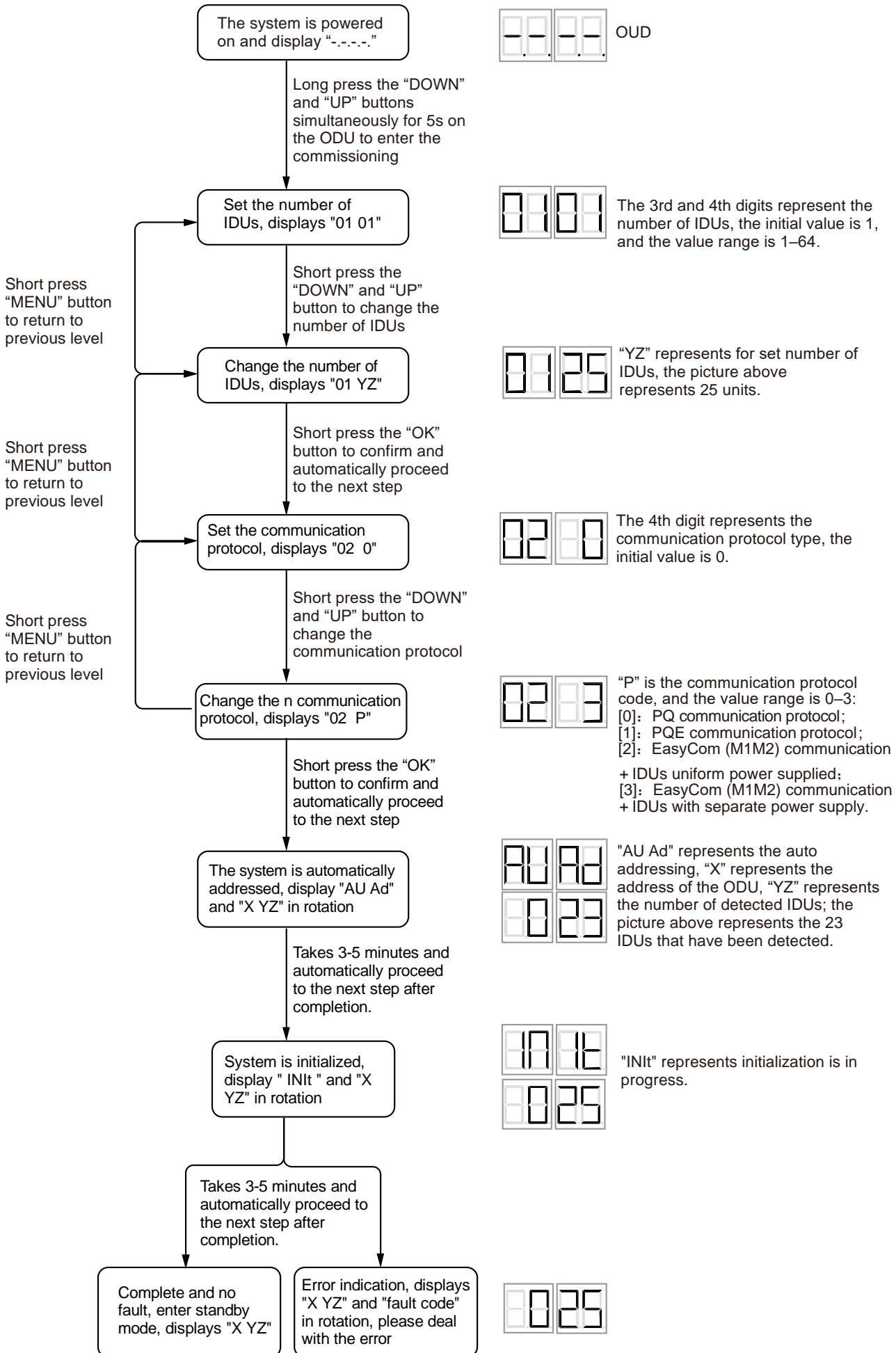

10.3 Multi-system Projects

For projects with multiple refrigerant systems, each independent refrigeration system (i.e. each system of one outdoor unit and its connected indoor units) should be given a test run independently, before the multiple systems that make up a project are run simultaneously.

10.4 Operating the system

10.4.1 Commissioning test run of single refrigerant system

Once all the pre-commissioning checks in Part 3. "Pre-commissioning Checks" have been completed, a test run should be performed as described below and a V8 Mini Series System Commissioning Report (see Part 3, 11 "Appendix to Part 3 – System Commissioning Report") should be completed as a record of the operating status of the system during commissioning.

Note: When running the system for commissioning test runs, if the combination ratio is 100% or less, run all the indoor units and if the combination ratio is more than 100%, run indoor units with total capacity equal to the capacity of the outdoor unit.

The test run procedure is as follows:

1. Open the outdoor unit liquid and gas stop valves.
2. Turn on the power to the outdoor unit.
3. If manual addressing is being used, set the addresses of each indoor unit.
4. Leave the power on for a minimum of 12 hours prior to running the system to ensure that the crankcase heaters have heated the compressor oil sufficiently.
5. Run the system:
 - a) Run the system in cooling mode with the following settings: temperature 17°C ; fan speed high.
 - b) After one hour, complete Sheet A of the system commissioning report then check the system parameters using the CHECK button on the outdoor unit's main PCB and complete the cooling mode columns of one Sheet D and one Sheet E of the system commissioning report for the outdoor unit.
 - c) Run the system in heating mode with the following settings: temperature 30°C ; fan speed high.
 - d) After one hour, complete Sheet B of the system commissioning report then check the system parameters using the CHECK button on the outdoor unit's main PCB and complete the heating mode columns of one Sheet D and one Sheet E of the system commissioning report for the outdoor unit.
6. Finally, complete Sheet C of the system commissioning report.

10.4.2 Commissioning test run of multiple refrigerant systems

Once the commissioning test run of each refrigerant system has been satisfactorily completed as per Part 3. "Commissioning test run of single refrigerant system", run the multiple systems that make up a project simultaneously and check for any abnormalities.

11 Appendix to Part 3 – System Commissioning Report

A total of up to 11 report sheets should be completed for each system:

- One Sheet A, one Sheet B and one Sheet C per system.
- One Sheet D and one Sheet E per outdoor unit.

System Commissioning Report – Sheet A

SYSTEM INFORMATION			
Project name and location		Customer company	
System name		Installation company	
Commissioning date		Agent company	
Outdoor ambient temp.		Commissioning engineer	
Outdoor unit information	Model	Serial no.	Power supply (V)

OUTDOOR UNIT								
COOLING MODE PARAMETER RECORD (After running in cooling mode for one hour)	Compressor suction pipe temperature		Current (A)					
	System pressure at check port		Within normal range?					
	INDOOR UNITS							
	(Sample of over 20% of the indoor units including the unit farthest from the outdoor unit)							
	Room no.	Model	Address	Set temp. (°C)	Inlet temp. (°C)	Outlet temp. (°C)	Drainage OK?	Abnormal noise/vibration?

System Commissioning Report – Sheet B

SYSTEM INFORMATION			
Project name and location		Customer company	
System name		Installation company	
Commissioning date		Agent company	
Outdoor ambient temp.		Commissioning engineer	
Outdoor unit information	Model	Serial no.	Power supply (V)

OUTDOOR UNIT								
COOLING MODE PARAMETER RECORD (After running in heating mode for one hour)	Compressor suction pipe temperature		Current (A)					
	System pressure at check port		Within normal range?					
	INDOOR UNITS							
	(Sample of over 20% of the indoor units including the unit farthest from the outdoor unit)							
	Room no.	Model	Address	Set temp. (°C)	Inlet temp. (°C)	Outlet temp. (°C)	Drainage OK?	Abnormal noise/vibration?

System Commissioning Report – Sheet C

Project name and location	System name
----------------------------------	--------------------

RECORD OF ISSUES SEEN DURING COMMISSIONING				
No.	Description of observed issue	Suspected cause	Troubleshooting undertaken	Serial no. of relevant unit
1				
2				
3				

OUTDOOR UNIT FINAL CHECKLIST	
SW2 system check performed?	
Any abnormal noise?	
Any abnormal vibration?	
Fan rotation normal?	

	Commissioning engineer	Dealer	Midea representative
Name:			
Signature:			
Date:			

System Commissioning Report – Sheet D

Project name and location	System name
----------------------------------	--------------------

DSP1 content	Parameters displayed on DSP2	Remarks	Observed values	
			Cooling mode	Heating mode
--	"Standby (ODU address+ IDU number)/frequency/special status"			
0--	Outdoor unit address	V8 Mini series outdoor unit: 0		
1--	Outdoor unit capacity (HP)	Actual value = value displayed		
2--	Number of outdoor units	V8 Mini series outdoor unit: 1		
3--	Number of indoor units set	Actual value = value displayed		
4--	Reserved			
5--	Target frequency of this ODU	Refer to Note 1		
6--	Reserved			
7--	Inverter compressor actual frequency (Hz)	Actual value = value displayed		
8--	Reserved			
9--	Operating mode	Refer to Note 2		
10--	Fan speed index (rpm)	Actual value = value displayed		
11--	Reserved			
12--	Indoor heat exchanger pipe (T2) average temperature (°C)	Actual value = value displayed		
13--	Indoor heat exchanger pipe (T2B) average temperature (°C)	Actual value = value displayed		
14--	Main heat exchanger pipe (T3) temperature (°C)	Actual value = value displayed		
15--	Outdoor ambient (T4) temperature (°C)	Actual value = value displayed		
16--	Liquid pipe (T5) temperature (°C)	Actual value = value displayed		
17--	Reserved			
18--	Plate heat exchanger outlet pipe (T6B) temperature (°C)	Actual value = value displayed		
19--	Inverter compressor A discharge (T7C1)temperature (°C)	Actual value = value displayed		
20--	Reserved			
21--	Inverter compressor A suction (T71) temperature (°C)	Actual value = value displayed		
22--	Reserved			
23--	Outdoor heat exchanger gas pipe(T8) temperature (°C)	Actual value = value displayed		
24--	Inverter module heatsink (Ntc)temperature (°C)	Actual value = value displayed		
25--	Reserved			
26--	Outdoor heat exchanger liquid pipe(TL)temperature (°C)	Actual value = value displayed		
27--	Discharge superheat degree (°C)	Actual value = value displayed		
28--	Primary current (A)	Actual value = value displayed /10		
29--	Inverter compressor A current (A)	Actual value = value displayed /10		
30--	Reserved			
31--	EEVA position	Actual value = value displayed × 24		
32--	Reserved			
33--	EEVC position	Actual value = value displayed × 4		

Table continued on next page ...

System Commissioning Report – Sheet D

Project name and location		System name		
<i>... table continued from previous page</i>				Observed values
DSP1 content	Parameters displayed on DSP2	Remarks	Cooling mode	Heating mode
34.--	Reserved			
35.--	Compressor discharge pressure (MPa)	Actual value = value displayed × 0.01		
36.--	Compressor suction pressure (MPa)	Actual value = value displayed × 0.01		
37.--	Number of indoor units online	Actual value = value displayed		
38.--	Number of indoor units operating	Actual value = value displayed		
39.--	Heat exchanger status (outdoor unit)	Refer to Note 3		
40.--	Special mode	Refer to Note 4		
41.--	Silent mode	0-5 ,5 represents the most silent		
42.--	Static pressure mode	Refer to Note 5		
43.--	Target evaporator (Tes) temperature (°C)	Actual value = value displayed Refer to Note 6		
43.--	Target condenser (Tcs) temperature (°C)	Actual value = value displayed Refer to Note 6		
45.--	DC Voltage (V)	Actual value = value displayed		
46.--	AC Voltage (V)	Actual value = value displayed		
47.--	Number of cooling mode IDUs	Actual value = value displayed		
48.--	Number of heating mode IDUs	Actual value = value displayed		
49.--	Capacity of cooling mode IDUs (HP)	Actual value = value displayed		
50.--	Capacity of heating mode IDUs (HP)	Actual value = value displayed		
51.--	Refrigerant volume judgment	Refer to Note 7		
52.--	Dirty blockage rate	0~10, 10 represents the worst		
53.--	Fan error			
54.--	Software version			
55.--	Last error code			
56.--	Reserved			
57.--	Reserved			
58.--	Reserved			
-- --	--	End		

- Notes:
1. Need to convert to current compressor output volume, example: For 8-10kW: compressor output volume is 24, Target frequency = Actual frequency * 24 / 60; for 12-16kW: compressor output volume is 42, Target frequency = Actual frequency * 42 / 60.
 2. Operating mode:
 - 0: off; 2: cooling; 3: heating.
 3. Heat exchanger status:
 - 0: off; 1: C1 : Condenser 2: D1: Reserved; 3: D2: Reserved; 4: E1: Evaporator; 5: F1 : Reserved; 6: F2: Reserved
 4. Special mode:
 - 0: no special mode; 1: oil return; 2: defrost; 3: start up; 4: stop; 5: quick check; 6: self cleaning.
 5. Static pressure mode:
 - 0: 0 Pa; 1: 10 Pa; 2: 20 Pa; 3: 30 Pa; 4: 35 Pa.
 6. Te: Low pressure equivalent saturation temperature (°C) Tes: Target Te value.
Tc: High pressure equivalent saturation temperature (°C) Tcs: Target Tc value.
 7. Refrigerant volume:
 - 0: no result; 1: critically insufficient; 2: significantly insufficient; 3: normal; 4: slightly excessive; 5: significantly excessive.

FOR OVER 30 YEARS WE HAVE BEEN OFFERING SOLUTIONS TO ENSURE SUSTAINABLE COMFORT AND THE WELL-BEING OF PEOPLE AND THE ENVIRONMENT

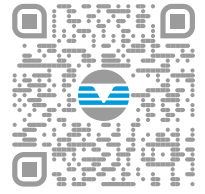

sales and service

www.clivet.com

MideaGroup
humanizing technology

Mini VRF - MSAN8-X 80M ÷ 160T - BT23B084GB-00



CLIVET S.p.A.

Via Camp Lonc 25, Z.I. Villapaiera 32032 - Feltre (BL) - Italy
Tel. +39 0439 3131 - info@clivet.it

CLIVET GMBH

Hummelsbütteler Steindamm 84,
22851 Norderstedt, Germany
Tel. +49 40 325957-0 - info.de@clivet.com

Clivet Group UK LTD

Units F5 & F6 Railway Triangle,
Portsmouth, Hampshire PO6 1TG
Tel. +44 02392 381235 -
Enquiries@Clivetgroup.co.uk

CLIVET LLC

Office 508-511, Elektrozavodskaya st. 24,
Moscow, Russian Federation, 107023
Tel. +7495 6462009 - info.ru@clivet.com

CLIVET MIDEAST FZCO

Dubai Silicon Oasis (DSO) Headquarter Building,
Office EG-05, P.O Box-342009, Dubai, UAE
Tel. +9714 3208499 - info@clivet.ae

Clivet South East Europe

Jarušiča 9b
10000, Zagreb, Croatia
Tel. +3851 222 8784 - info.see@clivet.com

CLIVET France

10, rue du Fort de Saint Cyr - 78180 Montigny le
Bretonneux, France
info.fr@clivet.com

Clivet Airconditioning Systems Pvt Ltd

Office No.501 & 502,5th Floor, Commercial -I,
Kohinoor City, Old Premier Compound, Off LBS
Marg, Kirod Road, Kurla West, Mumbai
Maharashtra 400070, India
Tel. +91 22 30930200 - sales.india@clivet.com