



# Water terminal unit for installation, wall-mounted

CFW-2 1-5

**MANUAL**  
FOR INSTALLATION,  
USE AND MAINTENANCE



Dear Customer,

We congratulate you on choosing this product

For many years Clivet has been offering systems that provide maximum comfort, together with high reliability, efficiency, quality and safety.

The aim of the company is to offer advanced systems, that assure the best comfort, reduce energy consumption and the installation and maintenance cost for the life cycle of the system.

The purpose of this manual is to provide you with information that is useful from reception of the equipment, through installation, operational usage and finally disposal so that this advanced system offers the best solution.

Yours faithfully,

CLIVET Spa

The data contained in this manual is not binding and may be changed by the manufacturer without prior notice.

Reproduction, even in part, is FORBIDDEN © Copyright - CLIVET S.p.A. - Feltre (BL) - Italia

---

Contents	pag
Installation manual .....	5
Owner's manual .....	15
Remote controller Owner's manual .....	23

To get complete and clear information, please also consider following issues

1 Model identification

CFW-2 1 - 5		
Size	Power supply	
1	230V	1-phase
2	230V	1-phase
3	230V	1-phase
4	230V	1-phase
5	230V	1-phase

Page intentionally left blank

# Installation manual

Page intentionally left blank

**CONTENTS**

**PAGE**

PRECAUTIONS.....	1
INSTALLATION INFORMATION.....	2
ATTACHED FITTINGS.....	3
INSPECTING AND HANDLING THE UNIT.....	4
INDOOR UNIT INSTALLATION.....	4
WATER PIPE INSTALLATION.....	6
WIRING CHART.....	6

**1. PRECAUTIONS**

- **Be sure to be in conformity with the local, national and international laws and regulations.**
- **Read "PRECAUTIONS" carefully before installation.**
- **The following precautions include important safety items. Observe them and never forget.**
- **Keep this manual in a handy place for future reference.**
- **Before out from factory, FAN COIL UNIT (AIR UNITS) has passed Fan Coil Overpressure Resistant Test, Statically and Dynamically Balanced Adjustment, Noise Test, Air (cool) Volume Test, Electric Property Test, Outline Quality Detection.**

The safety precautions listed here are divided into two categories. In either case, important safety information is listed which must be read carefully.



**WARNING**

Failure to observe a warning may result in death.



**CAUTION**

Failure to observe a caution may result in injury or damage to the equipment.

After completing the installation, make sure that the unit operates properly during the start-up operation. Please instruct the customer on how to operate the unit and keep it maintained.



**WARNING**

**Be sure only trained and qualified service personnel to install, repair or service the equipment.**  
Improper installation, repair, and maintenance may result in electric shocks, short-circuit, leaks, fire or other damage to the equipment.

**Install according to this installation instructions strictly.**  
If installation is defective, it will cause water leakage, electrical shock and fire.

**When installing the unit in a small room, take measures against to keep refrigerant concentration from exceeding allowable safety limits in the event of refrigerant leakage.**  
Contact the place of purchase for more information. Excessive refrigerant in a closed ambient can lead to oxygen deficiency.

**Use the attached accessories parts and specified parts for installation.**  
otherwise, it will cause the set to fall, water leakage, electrical shock and fire.

**The appliance must be installed 2.3m above floor.**

**The appliance shall not be installed in the laundry.**

**Before obtaining access to terminals, all supply circuits must be disconnected.**

**The appliance must be positioned so that the plug is accessible.**

**The enclosure of the appliance shall be marked by word, or by symbols, with the direction of the fluid flow.**

**For electrical work, follow the local national wiring standard, regulation and this installation instructions. An independent circuit and single outlet must be used.**  
If electrical circuit capacity is not enough or defect in electrical work, it will cause electrical shock fire.

**Use the specified cable and connect tightly and clamp the cable so that no external force will be acted on the terminal.**  
If connection or fixing is not perfect, it will cause heat-up or fire at the connection.

**Wiring routing must be properly arranged so that control board cover is fixed properly.**  
If control board cover is not fixed perfectly, it will cause heat-up at connection point of terminal, fire or electrical shock.

**If the supply cord is damaged, it must be replaced by the manufacture or its service agent or a similarly qualified person in order to avoid a hazard.**

**An all-pole disconnection switch having a contact separation of at least 3mm in all poles should be connected in fixed wiring.**

**When carrying out piping connection, take care not to let air substances go into refrigeration cycle.**  
Otherwise, it will cause lower capacity, abnormal high pressure in the refrigeration cycle.

**Do not modify the length of the power supply cord or use of extension cord, and do not share the single outlet with other electrical appliances.**  
Otherwise, it will cause fire or electrical shock.

**If the water leaks during installation, ventilate the area immediately.**

**After completing the installation work, check that the water does not leak.**

The cool water in the unit is not lower than 3°C, hot water is not higher than 70°C. Water in the unit must clean, air quality must meet to the standard of PH=6.5~7.5.



## CAUTION

### **Ground the air conditioner.**

Do not connect the ground wire to gas or water pipes, lightning rod or a telephone ground wire. Incomplete grounding may result in electric shocks.

### **Be sure to install an earth leakage breaker.**

Failure to install an earth leakage breaker may result in electric shocks.

### **Connect the outdoor unit wires, then connect the indoor unit wires.**

You are not allowed to connect the air conditioner with the power source until wiring and piping the air conditioner is done.

### **While following the instructions in this installation manual, install drain piping in order to ensure proper drainage and insulate piping in order to prevent condensation.**

Improper drain piping may result in water leakage and property damage.

### **Install the indoor and outdoor units, power supply wiring and connecting wires at least 1 meter away from televisions or radios in order to prevent image interference or noise.**

Depending on the radio waves, a distance of 1 meter may not be sufficient enough to eliminate the noise.

**This appliance is not intended for use by persons (including children) with reduced physical, sensory or mental capabilities, or lack of experience and knowledge, unless they have been given supervision or instruction concerning use of the appliance by a person responsible for their safety.**

### **Don't install the air conditioner in the following locations:**

- There is petrolatum existing.
- There is salty air surrounding (near the coast).
- There is caustic gas (the sulfide, for example) existing in the air (near a hot spring).
- The Volt vibrates violently (in the factories).
- In buses or cabinets.
- In kitchen where it is full of oil gas.
- There is strong electromagnetic wave existing.
- There are inflammable materials or gas.
- There is acid or alkaline liquid evaporating.
- Other special conditions.

## 2. INSTALLATION INFORMATION

- **To install properly, please read this "installation manual" at first.**
- **The air conditioner must be installed by qualified persons.**
- **When installing the indoor unit or its tubing, please follow this manual as strictly as possible.**
- **If the air conditioner is installed on a metal part of the building, it must be electrically insulated according to the relevant standards to electrical appliances.**
- **When all the installation work is finished, please turn on the power only after a thorough check.**
- **Regret for no further announcement if there is any change of this manual caused by product improvement.**











## INSTALLATION ORDER

- Select the location;
- Install the indoor unit;
- Install the outdoor unit;
- Connect the drain pipe;
- Wiring;
- Test operation.



### 3. ATTACHED FITTINGS

Please check whether the following fittings are of full scope. If there are some spare fittings , please restore them carefully.

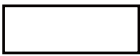
NAME	SHAPE	QUANTITY	FUNCTION
1. Screw ST3.9x25 for installation board		8	Secure the installation board
2. Plastic expanded tube		8	_____
3. Wrapping tape		1	_____
4. Drain pipe		1	_____
5. Wall conduit cover		1	_____
6. Remote controller (including operation manual)		1	_____
7. Frame		1	Hold the remote controller
8. Mounting screw(ST2.9 ×10-C-H)		2	Insulation Holder for remote controller
9. Alkaline dry batteries (AM4)		2	_____
10. Owner's manual	_____	1	_____
11. Installation manual	_____	1	This manual
12. seel gasket		4	For connect water pipe
13. Network matching wire		1	The indoor unit which at the terminal of communication system should connect a impedance between port X and port Y.
14. Insulation		1	Prevent the walls from getting damp
15 On / off input cable	_____	1	_____
16 0-10V input cable	_____	1	For connecting of of the fan speed
17 Modbus connection cable	_____	1	_____

#### Cautions on remote controller installation:

- Never throw or beat the controller.
- Before installation, operate the remote controller to determine its location in a reception range.
- Keep the remote controller at least 1m apart from the nearest TV set or stereo equipment. (it is necessary to prevent image disturbances or noise interferences.)
- Do not install the remote controller in a place exposed to direct sunlight or close to a heating source, such as a stove.
- Note that the positive and negative poles are right positions when loading batteries.
- This manual is subject to changes due to technological improvement without further notices.

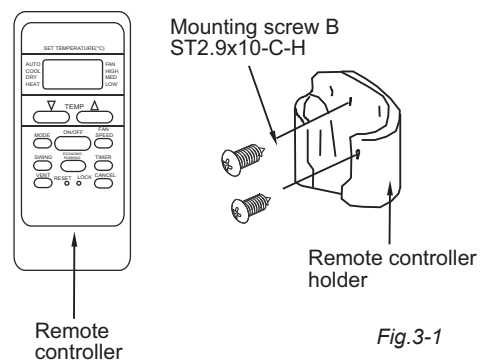



Fig.3-1

## 4. INSPECTING AND HANDLING THE UNIT

At delivery, the package should be checked and any damage should be reported immediately to the carrier claims agent.

When handling the unit, take into account the following:

- 1  Fragile, handle the unit with care.
- 2 Choose on before hand the path along which the unit is to be brought in.
- 3 Move this unit as originally package as possible.
- 4 When lifting the unit , always use protectors to prevent belt damage and pay attention to the position of the unit's centre of gravity.

## 5. INDOOR UNIT INSTALLATION

### 5.1 Installation place

**Before installing the unit, make sure with the user that there are no electric wires, water pipes etc. in the installation wall or floor to avoid damage. Installation in the following places may cause trouble.If it is unavoidable, please consult with the local dealer.**

- A place full of machine oil.
- A saline place such as coast.
- A place full of sulfide gas such as hot-spring resort.
- Places where there are high frequency machines such as wireless equipment, welding
- Machine, and medical facility.
- A place there is no combusive gases and volatile matter.
- A place of special environmental conditions.

#### ■ Indoor Unit

- A place where is no obstacle near the inlet and outlet area.
- A place which can beaf the indoor unit.
- A place which is convenient to maintenance.
- A place which provides the space around the indoor unit as required right in the diagram.
- There is strong electromagnetic wave exist-ing.
- A place which is far from heat, steam and inflammable gas.

### Functional spaces

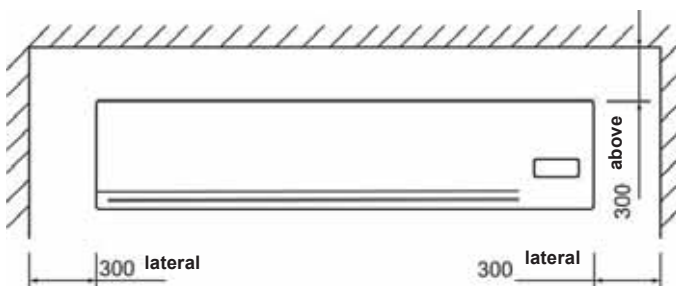

## 5.2 Drilling A Hole and Mounting Installation Board

Installation Board and Its Direction (unit: mm)

### 1\2\3 size

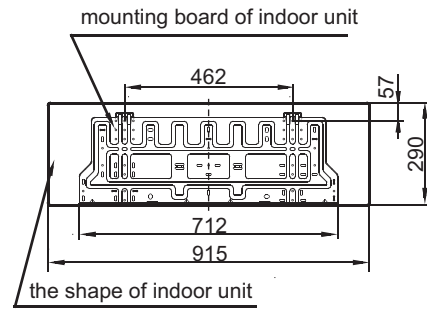

Fig.5-1

### 4\5 size

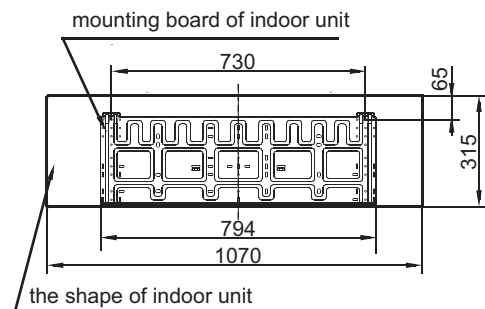

Fig.5-2

#### 1 Fix the installation board.

- It is recommended to install insulation between mounting board and wall to avoid wall getting damp.
- Install the installation board horizontally on structural parts in the wall with the spaces provided around the plate.
- In case of brick, concrete or similar type walls,make 5mmdia, holes in the wall. Insert clip anchors for appropriate mounting screws.

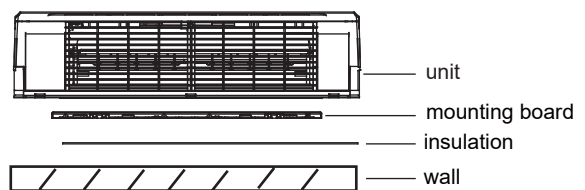
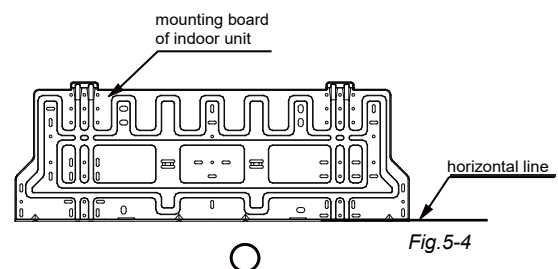

Fig.5-3

- Fix the installation board on the wall.

#### Right installation



### False installation

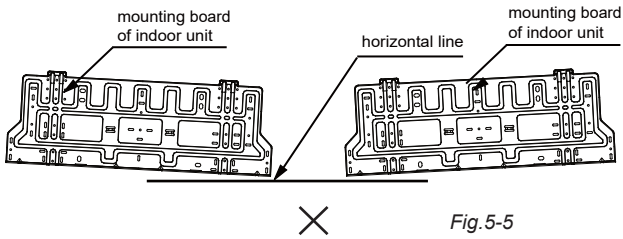

Fig.5-5

## 2 Drilling a hole.

- Determine the pipe hole position using the installation board, and drill the pipehole (N95mm) so it slants slightly downward.
- Always use a wall hole conduit when piercing metal lath, ply wood or metal plate.

## 5.3 Connective Pipe and Drainage Installation

### 1 Drainage

- Run the drain hose sloping downward. Do not install the drain hose as illustrated below.

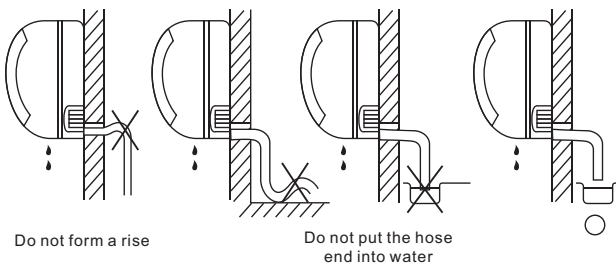

Fig.5-5

- When connection extension drain hose,insulate the connecting part of extension drain hose with a shield pipe

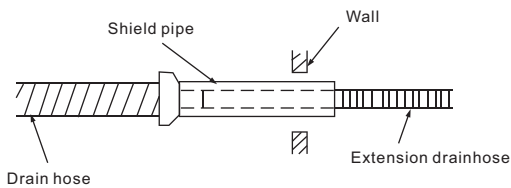

Fig.5-6

### 2 Connection pipe

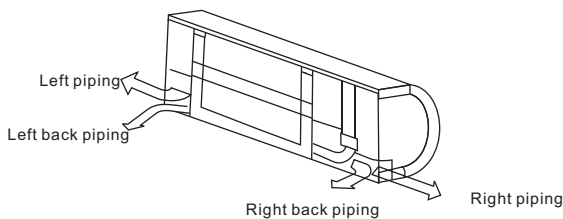

Fig.5-7

- For the left-hand and rear-left-hand piping,install the piping as shown. Bend the connective pipe to be laid at 43mm height or less from the wall.

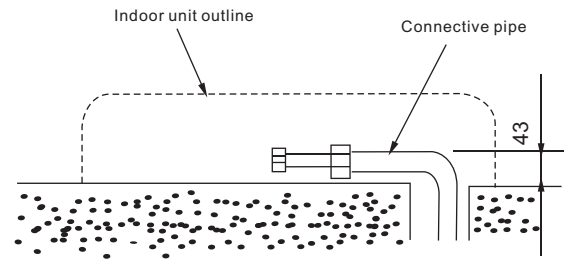

Fig.5-8

- Fix the end of the connective pipe.(Refer to Tightening Connection in WATER PIPING INSTALLATION) After connecting, all connective pipe should be covered by heat-resistant materials.



## CAUTIONS

Connect the indoor unit first then the outdoor unit and bend and arrange the pipe carefully.

Do not allow the piping to let out from the back of the indoor unit.

Be careful not to let the drain hose slack.

Insulate both of the auxiliary piping.

Banding the drain hose under the auxiliary pipe.

Do not allow the piping to let out from the back of the indoor unit.

### 3 Piping and bandaging

Wind the connective cable, drain hose and wiring with tape securely, evenly as shown below.

- Because the condensed water from rear of the indoor unit is gathered in Pond Box and is piped out of room. Do not put anything else in the box.

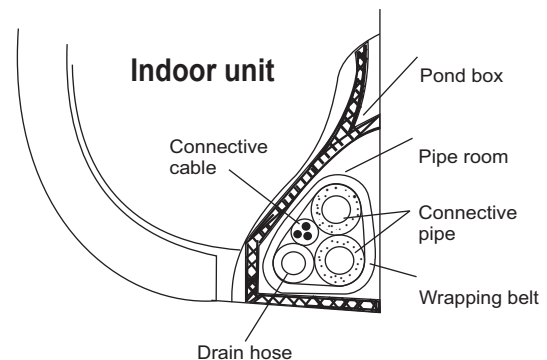

Fig.5-9

## 5.4 Indoor Unit Installation

- Pass the piping through the hole in the wall.
- Put the claw at the back of the indoor unit on the hook of the installation board, move the Indoor Unit from side to side to see that it is securely hooked.
- Piping can easily be made by lifting the indoor unit with a cushioning material between the indoor unit and the wall. Get it out after finish piping.
- Push the lower part of the Indoor Unit up to the wall, Then move the Indoor Unit from side to side, up and down to check if it is hooked securely.

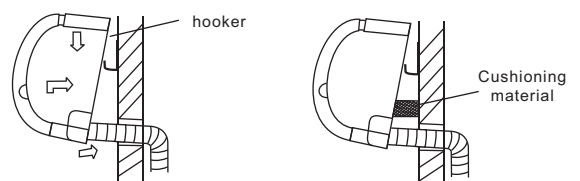

Fig.5-9-

## 6. WATER PIPE INSTALLATION

### 6.1 Material and Size of the Piping

Table 6-1

Pipe Material	Copper Pipe for Air Conditioner	
Model	42.5/51/68	85/102
Coil connections (flat plate)	3/4"	3/4"
	3/4"	3/4"

### 6.2 Connection of the Water Pipe

Connection of the water pipe should be done by professionals.  
Double-span should be used when connecting pipes of Indoor Unit.



#### NOTE

Please refer to installation instructions for the water piping connection of the air conditioner that with throttle device inside.

### Water fittings

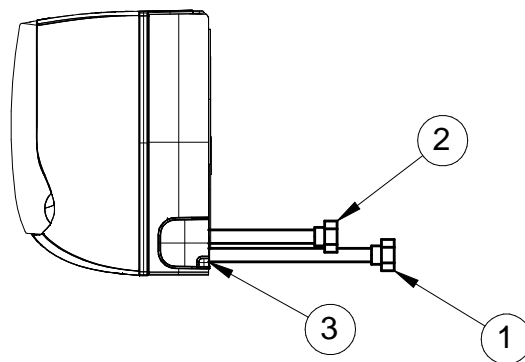

1. Water inlet  $\varnothing$  3/4"
2. Water outlet  $\varnothing$  3/4"
3. Condensate drain  $\varnothing$  20 mm

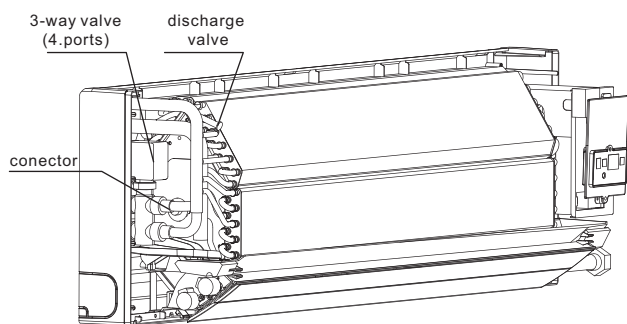

Fig. 6-1

- At the first debugging, completely expel air from coils via expelling valve.

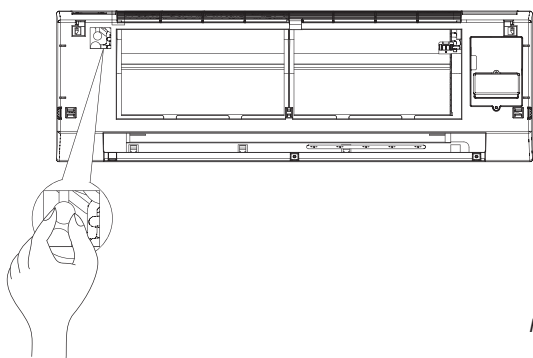

Fig. 6-2

## 7. WIRING CHART



### CAUTIONS

The reserved function is indicated in broken line table, users can select it when necessary.

an all-pole disconnection device which has at least 3mm separation distance in all pole and a residual current device(RCD)with the rating of above 10mA shall be incorporated in the fixed wiring according to the national rule.

The appliance shall be installed in accordance with national wiring regulations.

- 1 Take out the faceplate, then dismantle the display cover plate. (Refer to Fig 7-1)

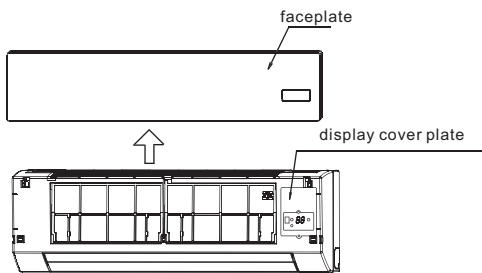

Fig. 7-1

- 2 Individual connect the power cord and signal line, adjust the dial switch. (Refer to Fig 7-2)

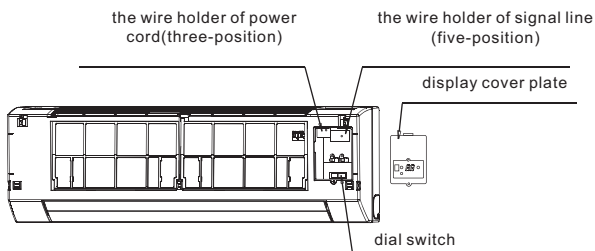

Fig. 7-2

## 7.1 Terminal Board Diagram

Please refer to the indoor unit wiring diagram for the wiring.



### NOTE

The air-conditioners can connect with Central Control Monitor (CCM). Before operation, please wiring correctly and set system address and network address of indoor units.

#### Single phase indoor unit

Table 7-1

Size	1	2	3	4	5
MCA	0,25	0,25	0,38	0,38	0,50
MFA	15	15	15	15	15
<b>IMF</b>					
kW	0,02	0,02	0,02	0,02	0,02
FLA	0,20	,20	0,30	,30	0,40
Power supply	220-240V~ 50Hz				

MCA: minimum circuit amps (A)

MFA: maximum fuse amps (A)

IMF: indoor fan motor

KW: rated motor output (kW)

FLA: Full load current at max admissible conditions (A)

Select the wire diameters (minimum value) individually for each unit based on the table 7.2.

Maximum allowable voltage range variation between phases is 2%

Select circuit breaker that having a contact separation in all poles not less than 3mm providing full disconnection.

The MFA is used to select the current circuit breakers and residual current operation breakers.

Table 7-2

Rated current of appliance (A)	Nominal cross-sectional area (mm <sup>2</sup> )	
	Flexible cords	Cable for fixed wiring
≤3	0,5 and 0,75	1 to 2,5
>3 and ≤6	0,75 and 1	1 to 2,5
>6 and ≤10	1 and 1,5	1 to 2,5
>10 and ≤16	1,5 and 2,5	1,5 to 4
>16 and ≤25	2,5 and 4	2,5 to 6
>25 and ≤32	4 and 6	4 to 10
>32 and ≤50	6 and 10	6 to 16
>50 and ≤63	10 and 16	10 to 25



### Caution

Refer to local laws and regulations when deciding on the dimensions for the power cords and wiring.

Get a professional to select and install the wiring.

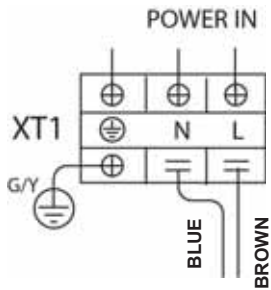

**INDOOR UNIT POWER**  
220-240V~50Hz

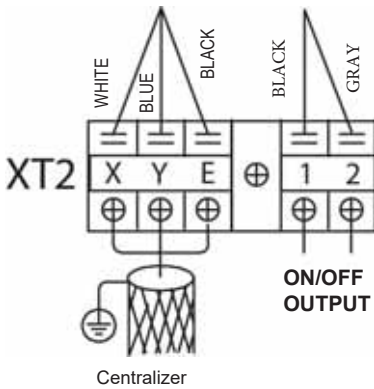

## 7.2 Network address set (MODBUS)

Every air-conditioner in network has only one network address to distinguish each other. Address code of air-conditioner in LAN is set by code switch on Network Interface Module (NIM), and the set range is 0-64.

Table 7-1

Toggle switch set			Network address code
SW1	ENC2		
			01~16
			17~32
			33~48
			49-64

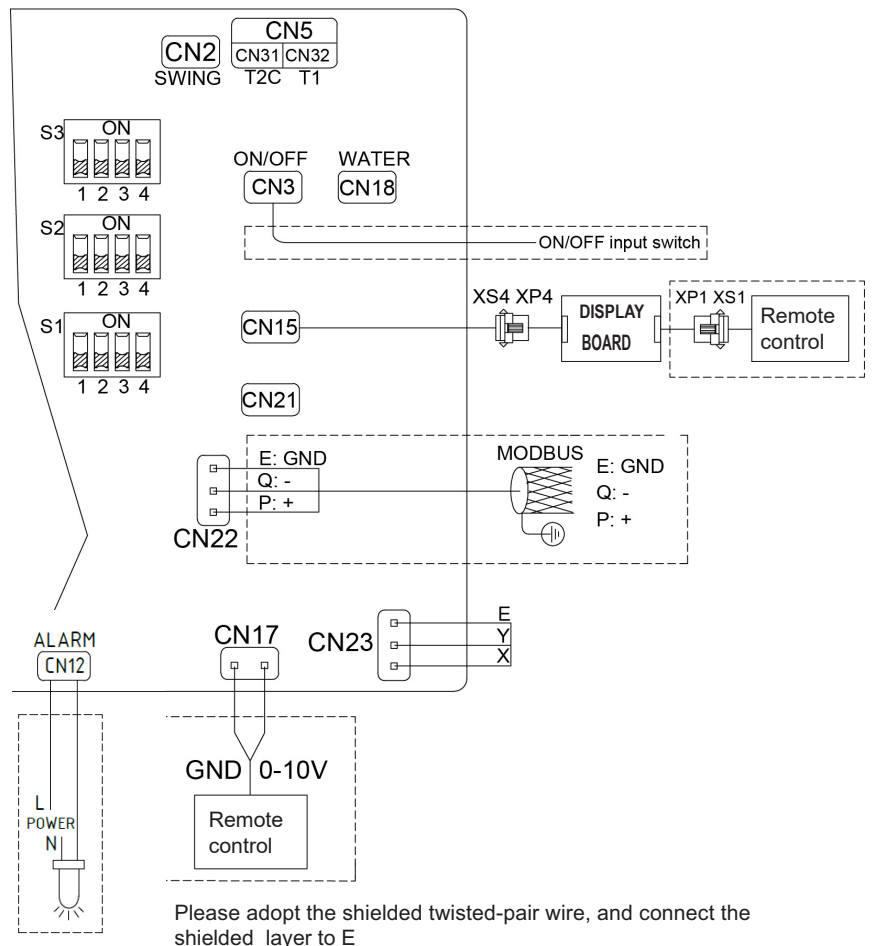

Please adopt the shielded twisted-pair wire, and connect the shielded layer to E

**PEMW00002**  
Alarm output  
signal cable  
L=500mm



Classes	0-10V input	Fan speed
<b>3 speed fan</b>	0 < voltage < 3	Off
	3 < voltage < 5	Low
	5 < voltage < 7	Med
	7 < voltage < 10	High

# Owner's manual

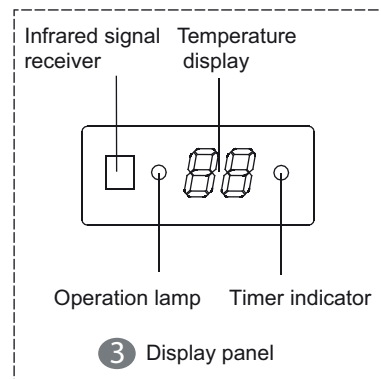
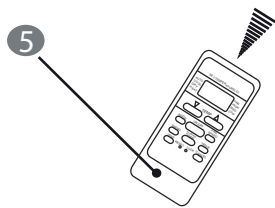
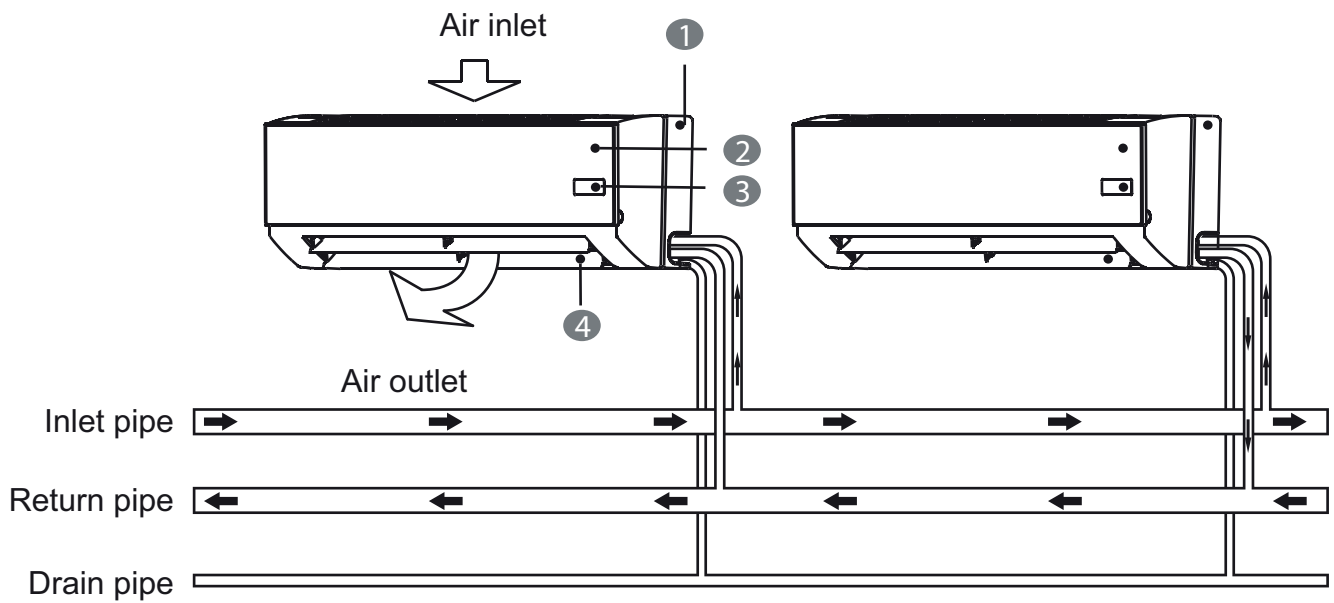

- 1 Bottom plate
- 2 Faceplate
- 3 Display panel
- 4 Horizontal air deflector
- 5 Remote controller



# 1. IMPORTANT SAFETY INFORMATION

To prevent injury to the user or other people and property damage, the following instructions must be followed. Incorrect operation due to ignoring of instructions may cause harm or damage.

The safety precautions listed are divided into two categories. In either case, important safety information is listed which must be read carefully.



## WARNING

Failure to observe a warning may result in death.



## CAUTION

Failure to observe a caution may result in injury or damage to the equipment.



## WARNING

**Do not cut off the power supply manually when the air conditioner running, otherwise malfunction would be caused.**

**Ask your dealer for installation of the air conditioner.**

Incomplete installation performed by yourself may result in a water leakage, electric shock, and fire.

**Ask your dealer for improvement, repair, and maintenance.**

Incomplete improvement, repair, and maintenance may result in a water leakage, electric shock, and fire.

**In order to avoid electric shock, fire or injury, or if you detect any abnormality such as smell of fire, turn off the power supply and call your dealer for instructions.**

**Never let the indoor unit or the remote controller get wet.**

It may cause an electric shock or a fire.

**Never press the button of the remote controller with a hard, pointed object.**

The remote controller may be damaged.

**Never replace a fuse with that of wrong rated current or other wires when a fuse blows out.**

Use of wire or copper wire may cause the unit to break down or cause a fire.

**It is not good for your health to expose your body to the air flow for a long time.**

**Do not insert fingers, rods or other objects into the air inlet or outlet.**

When the fan is rotating at high speed, it will cause injury.

**Never use a flammable spray such as hair spray, lacquer or paint near the unit.**

It may cause a fire.

**Never touch the air outlet or the horizontal blades while the swing flap is in operation.**

Fingers may become caught or the unit may break down.

**Never put any objects into the air inlet or outlet.**

Objects touching the fan at high speed can be dangerous.

**Never inspect or service the unit by yourself.**

Ask a qualified service person to perform this work.

**Do not dispose this product as unsorted municipal waste. Collection of such waste separately for special treatment is necessary.**

**To prevent water leak, contact your dealer.**

When the system is installed and runs in a small room, it is required to keep the concentration of the water, if by any chance coming out, below the limit. The cool capacity would be lower.

**Turn off any combustible heating devices, ventilate the room, and contact the dealer where you purchased the unit.**

Do not use the air conditioner until a service person confirms that the portion where the water leaks is repaired.



## CAUTION

**Do not use the air conditioner for other purposes.**

In order to avoid any quality deterioration, do not use the unit for cooling precision instruments, food, plants, animals or works of art.

**Before cleaning, be sure to stop the operation, turn the breaker off or pull out the supply cord.**

Otherwise, an electric shock and injury may result.

**In order to avoid electric shock or fire, make sure that an earth leak detector is installed.**

**Be sure the air conditioner is grounded.**

In order to avoid electric shock, make sure that the unit is grounded and that the earth wire is not connected to gas or water pipe, lightning conductor or telephone earth wire.

**In order to avoid injury, do not remove the fan guard of the outdoor unit.**

**Do not operate the air conditioner with a wet hand.**

An electric shock may happen.

**Do not touch the heat exchanger fins.**

These fins are sharp and could result in cutting injuries.

**Do not place items which might be damaged by moisture under the indoor unit.**

Condensation may form if the humidity is above 80%, the drain outlet is blocked or the filter is polluted.

**After a long use, check the unit stand and fitting for damage.**

If damaged, the unit may fall and result in injury.

**To avoid oxygen deficiency, ventilate the room sufficiently if equipment with burner is used together with the air conditioner.**

**Arrange the drain hose to ensure smooth drainage.**

Incomplete drainage may cause wetting of the building, furniture etc.

**Never touch the internal parts of the controller.**

Do not remove the front panel. Some parts inside are dangerous to touch, and a machine trouble may happen.

**Never expose little children, plants or animals directly to the air flow.**

Adverse influence to little children, animals and plants may result.

**Do not allow a child to mount on the outdoor unit or avoid placing any object on it.**

Falling or tumbling may result in injury.

**Do not operate the air conditioner when using a room fumigation - type insecticide.**

..... .. observe could cause the chemicals to become deposited in the unit, which could endanger the health of those who are hypersensitive to chemicals.

**Do not place appliances which produce open fire in places exposed to the air flow from the unit or under the indoor unit.**

It may cause incomplete combustion or deformation of the unit due to the heat.

**Do not install the air conditioner at any place where flammable gas may leak out.**

If the gas leaks out and stays around the air conditioner, a fire may break out.

**The appliance is not intended for use by young children or infirm persons without supervision.**

**Young children should be supervised to ensure that they do not play with the appliance.**



**DISPOSAL:** Do not dispose this product as unsorted municipal waste. Collection of such waste separately for special treatment is necessary.

■ Do not dispose of electrical appliances as unsorted municipal waste, use separate collection facilities.

■ Contact your local government for information regarding the collection systems available.

If electrical appliances are disposed of in landfills or dumps, hazardous substances can leak into the groundwater and get into the food chain, damaging your health and well-being

## 2. PARTS NAMES

The air conditioner consists of the indoor unit, the outdoor unit, the connecting pipe and the remote controller.

### ■ Temporary button

#### C faceplate

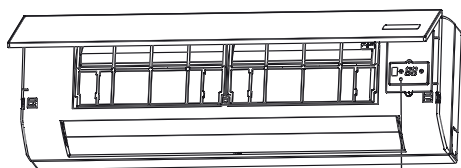

#### S faceplate

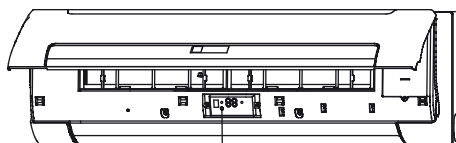

Temporary button

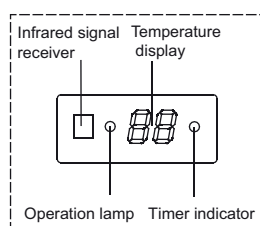

Fig.2-1

Open the faceplate, and you can find the temporary button on the display panel. (Refer to Fig 2-1)

This function is used to operate the unit temporarily in case you misplace the remote controller or its batteries are exhausted. Two modes including AUTO and FORCED COOL can be selected through the TEMPORARY BUTTON. Once you push this button, the air conditioner will run in such order: AUTO, FORCED COOL, OFF, and back to AUTO.

- 1 AUTO  
The OPERATION lamp is lit, and the air conditioner will run under AUTO mode. The remote controller operation is enabled to operate according to the received signal.
- 2 FORCED COOL  
The OPERATION lamp flashes, the air conditioner will turn to AUTO after it is enforced to cool with a wind speed of HIGH for 30 minutes. The remote controller operation is disabled.
- 3 OFF  
The OPERATION lamp goes off. The air conditioner is OFF while the remote controller operation is enabled.



### NOTE

This manual does not include Remote Controller Operations, see the <<Remote Controller Owner's manual>> packed with the unit for details.

## 3. OPERATION RANGE

Use the system in the following temperature for safe and effective operation.

Table 3-1

Temperature Mode	Outdoor temperature	Room temperature	water inlet temperature
Cooling operation	21°C~43°C	17°C~32°C	3°C~20°C
Heating operating (cooling only type without)	-5°C~24°C	0°C~30°C	30°C~70°C



### NOTE

- 1 If air conditioner is used outside the above conditions, it may cause the unit to function abnormally.
- 2 The phenomenon is normal that the surface of air conditioning may condense water when the relative larger humidity in room, please close the door and window.
- 3 Optimum performance will be achieved within these operating temperature range.
- 4 Water system operating pressure: Max: 1.6MPa, Min: 0.15MPa.

## 4. HINTS FOR ECONOMICAL OPERATION

The following should be noticed to ensure an economical operation.

- Adjust the air flow louver properly and avoid direct air flow to room inhabitants.
- Adjust the room temperature properly for a comfortable environment. Avoid excessive heating or cooling.
- Prevent direct sunlight during cooling operation by using curtains or blinds.
- Ventilate often. Extended use requires special attention to ventilation.
- Keep doors and windows closed. If the doors and windows remain open, air will flow out of your room causing a decrease in the cooling or heating effect.
- Never place objects near the air inlet or the air outlet of the unit. It may cause deterioration in the effect or stop the operation.
- Never place objects near the air inlet or the air outlet of the unit. It may cause deterioration in the effect or stop the operation.
- Set the timer .
- If you don't plan to use the unit for a long time, please take the batteries from the remote controller . When the power is on, some energy will be consumed,even if the air conditioner isn't in operation. So please disconnect the power to save energy.
- Keep the indoor unit and remote controller at least 1 m away from televisions, radios, stereos, and other similar equipment. Failing to do so may cause static or distorted pictures.
- A dirty air filter will reduce cooling or heating efficiency, please clean it once two weeks.

## 5. ADJUSTING AIR FLOW DIRECTION

While the unit is in operation, you can adjust the air flow louver to change the flow direction and naturalize the room temperature evenly. Thus you can enjoy it more comfortably.

- **Adjust horizontal air**  
Adjust horizontal air deflector by remote controller.

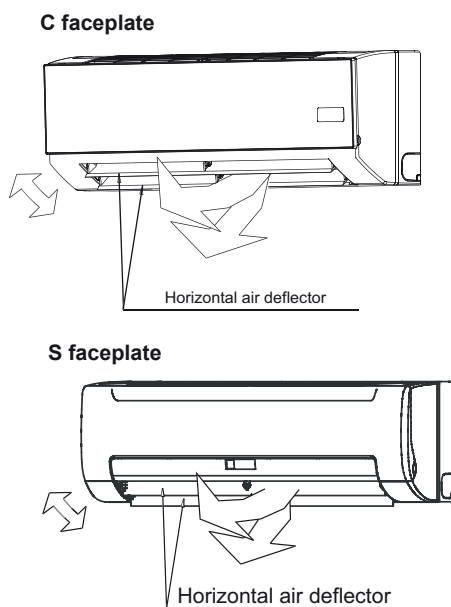

Fig.5-1

- **Adjust vertical air**  
Open the horizontal air deflector, and then manually adjust vertical air deflector.

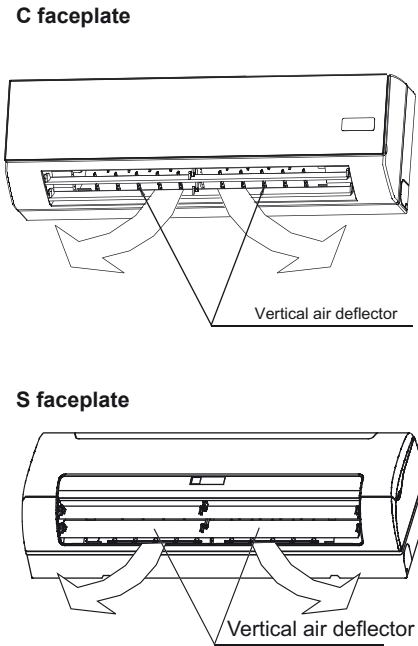

Fig.5-2

## 6. MAINTENANCE



### CAUTION

Before you clean the air conditioner, be sure the power supply is off.

Check if the wiring is not broken off or disconnected.

Disconnect the power supply before cleaning and maintenance. Use dry cloth to clean the unit.

Use a dry cloth to wipe the indoor unit and remote controller.

A wet cloth may be used to clean the indoor unit if it is very dirty.

Never use a damp cloth on the remote controller.

Do not use a chemically-treated duster for wiping or leave such material on the unit for long. it may damage or fade the surface of the unit.

Do not use benzine, thinner, polishing powder, or similar solvents for cleaning. These may cause the plastic surface to crack or deform.

- **Maintenance after a long stop period**

(eg. at the beginning of the season)

Check and remove everything that might be blocking inlet and outlet vents of indoor units and outdoor units.

Clean air filters and casings of indoor units. Refer to "Cleaning the air filter" for details on how to proceed and make sure to install cleaned air filters back in the same position.

### ■ Maintenance before a long stop period

(eg. at the beginning of the cold season)

Drain the water system(for all heat exchangers).

To avoid the risk of rupture due to freezing, it is advisable to drain the water from the system at the beginning of the cold season

### ■ Maintenance before a long stop period

(eg. at the end of the season)

Let the indoor units run in fan only operation for about half a day in order to dry the interior of the units.

Clean air filters and casings of indoor units. Refer to "Cleaning the air filter" for details on how to proceed and make sure to install cleaned air filters back in the same position.

### ■ Cleaning the air filter and net of clear air

The air filter can prevent the dust or other particulate from going inside. In case of blockage of the filter, the working efficiency of the air conditioner may greatly decrease. Therefore, the filter must be cleaned once two weeks during long time usage.

If the air conditioner is installed in a dust place, clean the the air filter frequent.

If the accumulated dust is too heavy to be cleaned, please replace the filter with a new one(replaceable air filter is an optional fitting).

- 1 **Open the faceplate, then Dismantle the air filter and net of clear air.**
- 2 **Clean the air filter**  
Vacuum cleaner or pure water may be used to clean the air filter. If the dust accumulation is too heavy, please use soft brush and mild detergent to clean it and dry out in cool place.
  - *The air-in side should face up when using vacuum cleaner. (Refer to Fig 6-2)*
  - *The air-in side should face down when using water. (Refer to Fig 6-3)*
- 3 **Re-install the air filter and net of clear air.**
- 4 **Close the faceplate.**

S faceplate

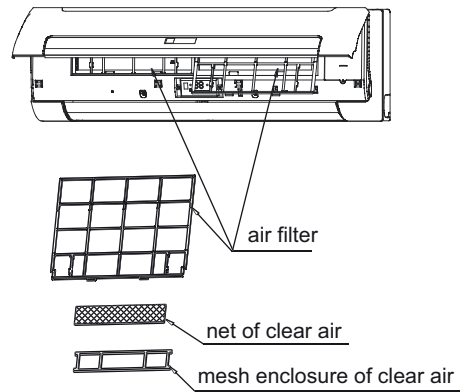

Fig.6-1

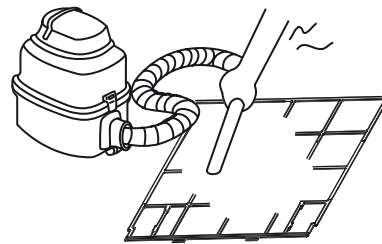

Fig.6-2

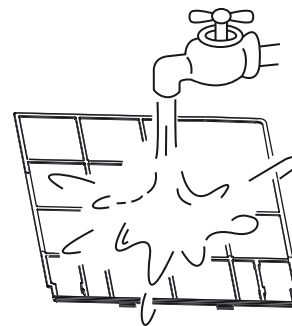

Fig.6-3

## 7. FOLLOWING SYMPTOMS ARE NOT AIR CONDITIONER TROUBLES

### Symptom 1: The system does not operate

- The air conditioner does not start immediately after the ON/OFF button on the remote controller is pressed.  
If the operation lamp lights, the system is in normal condition. To prevent overloading of the compressor motor, the air conditioner starts 3 minutes after it is turned ON.
- If the operation lamp and the "PRE-DEF indicator (cooling and heating type) or fan only indicator (cooling only type)" light, it means you choose the heating model. When just starting, if the compressor has not started, the indoor unit appears "anti cold wind" protection because of its overlow outlet temperature.

### Symptom 2: Change into the fan mode during cooling mode

- In order to prevent the indoor evaporator frosting, the system will change into fan mode automatically, restore to the cooling mode after soon.
- When the room temperature drops to the set temperature, the compressor goes off and the indoor unit changes to fan mode; when the temperature rises up, the compressor starts again. It is same in the heating mode.



### CAUTION

Do not dry out the air filter under direct sunshine or with fire.

C faceplate

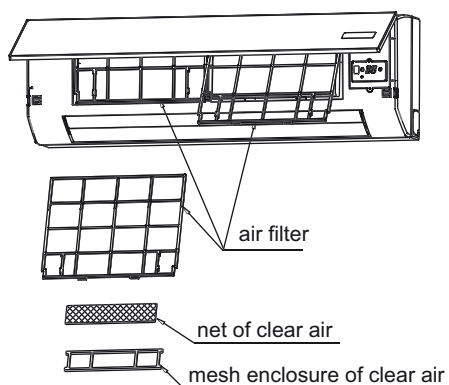

### Symptom 3: White mist comes out of a unit

#### Symptom 3.1: Indoor unit

- When humidity is high during cooling operation If the interior of an indoor unit is extremely contaminated, the temperature distribution inside a room becomes uneven. It is necessary to clean the interior of the indoor unit. Ask your dealer for details on cleaning the unit. This operation requires a qualified service person.

#### Symptom 3.2: Indoor unit, outdoor unit

- When the system is changed over to heating operation after defrost operation Moisture generated by defrost becomes steam and is exhausted.

### Symptom 4: Noise of air conditioners cooling

#### Symptom 4.1: Indoor unit

- A continuous low "shah" sound is heard when the system is in cooling operation or at a stop. When the drain pump (optional accessories) is in operation, this noise is heard.
- A "pishi-pishi" squeaking sound is heard when the system stops after heating operation. Expansion and contraction of plastic parts caused by temperature change make this noise.

#### Symptom 4.2: Outdoor unit

- When the tone of operating noise changes. This noise is caused by the change of frequency.

### Symptom 5: Dust comes out of the unit

- When the unit is used for the first time in a long time. This is because dust has gotten into the unit.

### Symptom 6: The units can give off odours

- The unit can absorb the smell of rooms, furniture, cigarettes, etc., and then emit it again.

### Symptom 7: The outdoor unit fan does not spin.

- During operation. The speed of the fan is controlled in order to optimize product operation.

Table 7-1

1	Malfunction	EEPROM communication error	Operating LED (1 <sup>ST</sup> ) and Timer LED (2 <sup>nd</sup> ) flash in 5Hz frequency	E7	Can't be recovery
2	Malfunction	Room temperature sensor probe abnormal	Timer LED (2 <sup>nd</sup> ) flash in 5Hz frequency	E2	Recover automatically after clear
3	Malfunction	Coil temperature sensor probe abnormal (4-pipe with 2 coil sensor for cooling and heating)	Operating LED (1 <sup>ST</sup> ) flash in 5Hz frequency	E3	
4	Protection	Water level exceed the alarm level	Water-level alarm LED (4 <sup>th</sup> ) flash in 5Hz frequency	EE	Recover automatically after clear
5	Protection	Remote OFF	Defrosting LED (3rd) flash in 5Hz frequency	--	Not treat as malfunction, and not output malfunction

## 8. TROUBLESHOOTING

### 8.1. Troubles and causes of air conditioner

If one of the following malfunctions occur, stop operation, shut off the power, and contact with your dealer.

- The operation lamp is flashing rapidly (twice every second) This lamp is still flashing rapidly after turn off the power and turn on again.
- Remote controller receives malfunction or the button does not work well.
- A safety device such as a fuse, a breaker frequently actuates.
- Water leaks from indoor unit.
- Other malfunctions.

### 8.2. Troubles and causes of remote controller

Before asking for serving or repairing , check the following points.

(Refer to Table 8-2)

Table 8-1

Symptoms	Causes	Solution
The unit does not start	<ul style="list-style-type: none"> <li>Power outage.</li> <li>The on-off switch is in the off position.</li> <li>Blown fuse or broken power switch.</li> <li>The batteries in the remote are dead or there is another problem with the remote.</li> </ul>	<ul style="list-style-type: none"> <li>Wait for the comeback of power.</li> <li>Switch on the power.</li> <li>Replace the fuse.</li> <li>Replace the batteries or check the controller.</li> </ul>
Air circulates normally but cooling is insufficient	<ul style="list-style-type: none"> <li>Temperature is not set correctly.</li> </ul>	<ul style="list-style-type: none"> <li>Set the temperature properly.</li> </ul>
Limited cooling effect	<ul style="list-style-type: none"> <li>Indoor unit heat exchanger is dirty.</li> <li>The air filter is dirty.</li> <li>Inlet of indoor units is blocked.</li> <li>Doors and windows are open</li> <li>Sunlight directly shine.</li> <li>Too much heat resource.</li> <li>Outdoor temp. is too high.</li> </ul>	<ul style="list-style-type: none"> <li>Clean the heat exchanger.</li> <li>Clean the air filter.</li> <li>Eliminate all dirties and make air smooth.</li> <li>Close doors and windows.</li> <li>Make curtains in order to shelter from sunshine.</li> <li>Reduce heat source.</li> <li>AC cooling capacity reduces (normal).</li> </ul>
Limited heating effect	<ul style="list-style-type: none"> <li>Outdoor temperature is lower than 7°C .</li> <li>Doors and windows not completely closed.</li> </ul>	<ul style="list-style-type: none"> <li>Use heating device.</li> <li>Close doors and windows.</li> </ul>

Table 8-2

Symptoms	Causes	Solution
The fan speed can not be changed.	<ul style="list-style-type: none"> <li>Check whether the MODE indicated on the display is "AUTO"</li> </ul>	When the automatic mode is selected, the air conditioner will automatically change the fan speed.
	<ul style="list-style-type: none"> <li>Protection against hot wind in cooling mode.</li> <li>Protection against cold wind in heating mode.</li> </ul>	Reduce the temperature of inlet in cooling mode rise the temperature of inlet in heating mode.
The remote controller signal is not transmitted even when the ON/OFF button is pushed.	<ul style="list-style-type: none"> <li>Check whether the batteries in the remote controller are exhausted.</li> </ul>	The power supply is off.
The TEMP. indicator does not come on.	<ul style="list-style-type: none"> <li>Check whether the MODE indicated on the display is FAN ONLY</li> </ul>	The temperature cannot be set during FAN mode.
The indication on the display disappears after a lapse of time.	<ul style="list-style-type: none"> <li>Check whether the timer operation has come to an end when the TIMER OFF is indicated on the display.</li> </ul>	The air conditioner operation will stop up to the set time
The TIMER ON indicator goes off after a lapse of certain time.	<ul style="list-style-type: none"> <li>Check whether the timer operation is started when the TIMER ON is indicated on the display.</li> </ul>	Up to the set time, the air conditioner will automatically start and the appropriate indicator will go off.
No receiving tone sounds from the indoor unit even when the ON/OFF button is pressed.	<ul style="list-style-type: none"> <li>Check whether the signal transmitter of the remote controller is properly directed to the infrared signal receiver of the indoor unit when the ON/OFF button is pressed.</li> </ul>	Directly transmit the signal transmitter of the remote controller to the infrared signal receiver of the indoor unit, and then repeatedly push the ON/OFF button twice.

# **Remote controller Owner's manual**

## NOTE

1. The outline figure on cover is for reference only, which may differ from what you purchased.
2. Make sure to read chapter PRECAUTIONS before you operate the air conditioner.
3. This manual is available for model R05/BGE , RM05/BG(T)E-A and RM05/BGE(T).
4. R05/BGE, RM05/BG(T)E-A and RM05/BGE(T) can be applicable for cool only type and cool&heat type air conditioners.

## REMOTE CONTROLLER OWNER'S MANUAL

## CONTENTS

PRECAUTIONS.....	1
MODEL AND SPECIFICATION.....	1
BUTTONS AND THEIR FUNCTIONS.....	2
INDICATORS AND FUNCTIONS.....	5
OPERATION INSTRUCTIONS.....	6
INSTALL AND REPLACE BATTERIES.....	6
AUTO OPERATION.....	6
COOL/HEAT/FAN OPERATION.....	6
DRY OPERATION.....	7
TIMER OPERATION.....	7

R05/BGE-20



## PRECAUTIONS

- Curtain, door or the like objects will prevent the remote signal from being received by air conditioner.
- Do not get the interior of remote controller wet. It is forbidden to expose it to direct sunlight or locate it in the place with high temp.
- Malfunction may occur if infrared signal receiver on air conditioner is exposed to sunlight. Please shelter the signal receiver from sunlight with curtain.
- Please remove the nearby electronic device for they may affect the performance of remote controller.
- Do not put the used or different batteries into the remote controller, otherwise remote controller will fail to send signal.
- Please remove the batteries before long period unused, otherwise the remote controller may be damaged.
- If pressing the button reset the remote controller, which indicates low battery, please replace the batteries.
- If no receiving sound is heard from indoor unit or  on remote controller does not flash, please replace the batteries.
- Effective transmitting distance of remote controller is 8m, please aim the signal sending part to the receiver on air conditioner.

## MODEL AND SPECIFICATION

Model	R05/BGE RM05/BGE(T) RM05/BG(T)E-A
Rated voltage	3.0V(2 pieces of LR03 7# batteries)
Min voltage for sending signal of CPU	2.4V
Effective receiving distance	8m~11m
Operation condition	-5~60°C

## BUTTONS AND THEIR FUNCTIONS

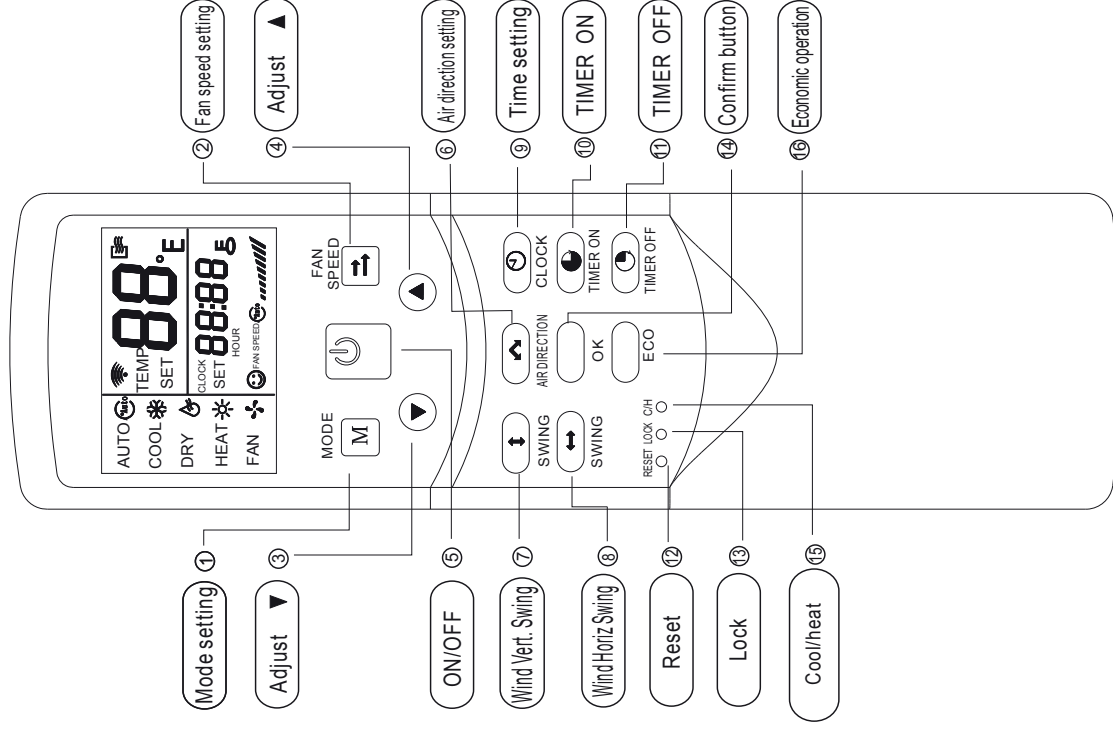

Chart 1

- ① **MODE:** Once pressing, running mode will be selected in the following sequence:



**NOTE: No heating mode for cool only type unit.**

- ② **FAN SPEED:** Fan speed will be selected in following sequence once pressing this button:
- 
- ```
graph LR; A[AUTO] --> B[LOW]; B --> C[MED]; C --> D[HIGH];
```
- ③ **Adjust▼:** Decrease the set temp. Keeping pressing will decrease the temp with 1°C per 0.5s.
- ④ **Adjust▲:** Increase the set temp. Keeping pressing will increase the temp with 1°C per 0.5s.
- ⑤ **ON/OFF:** For turning on or turning off the air conditioner.
- ⑥ **AIR DIRECTION:** Activate swing function of air deflector. Once pressing, air deflector will turn 6°C. For normal operation and better cooling and heating effect, deflector will not turn to the degree which is the state of deflector when the unit is turned off. (Only available when remote controller is used with corresponding unit.)
- ⑦ **Wind Vert Swing:** Activate or turn off wind vertical swing function. (Only available when remote controller is used with corresponding unit.)
- ⑧ **Wind Horiz Swing:** Activate or turn off wind horizontal swing function. (Only available when remote controller is used with corresponding unit.)
- ⑨ **CLOCK:** Display the current time. (12:00 is displayed when resetting or electrifying for the first time.) Press **CLOCK** for 5s, icon indicating hour will flash with 0.5s. Press it again, icon indicating minute will flash with 0.5s. ▼ and ▲ are used

to adjust the figure. Setting or modification is effective only by pressing OK button to make confirmation.

- ⑩ **TIME ON:** For time ON setting. Once pressing this button, the time will increase by 0.5 hour. When the set time exceeds 10 hours, pressing the button will increase the time by 1 hour. Adjusting the figure to 0.00 will cancel time ON setting.
- ⑪ **TIME OFF:** For time OFF setting. Once pressing this button, the time will increase by 0.5 hour. When the set time exceeds 10 hours, pressing the button will increase the time by 1 hour. Adjust the figure to 0.00 will cancel time ON setting.
- ⑫ **RESET (inner located):** Press this button with a needle of 1mm to cancel the current setting and reset remote controller.
- ⑬ **LOCK (inner located):** Press this button with a needle of 1mm to lock or unlock the current setting.
- ⑭ **OK:** Used to confirm the time setting and modification.
- ⑮ **COOL/HEAT (inner located):** Press this button with a needle of 1mm to shift mode between COOL only and COOL&HEAT. During setting, back light will be lightened. Factory default mode is COOL &HEAT.
- ⑯ **ECO:** Activate or turn off economic operation mode. It is suggested to turn on this function when sleeping. (Only available when remote controller is used with corresponding unit.)

## INDICATORS AND FUNCTIONS

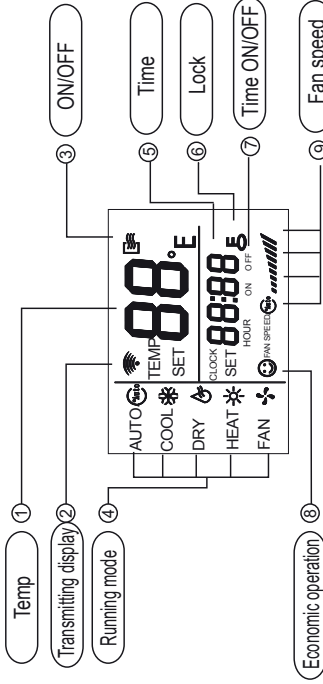

Chart 2

- Temp: Display the set temperature. Adjust temperature via ▲ and ▼ . No display in this area if the unit is on FAN mode.
- Transmitting display: The icon will flash once when the signal is sent by remote controller.
- ON/FF: Icon is displayed when the remote controller is turned on, or vice versa.
- Running mode: Press MODE to display current running mode. AUTO, COOL, DRY, HEAT and FAN can be selected. (HEAT function is invalid for cool only type unit.)
- Time: Display the current set time. Press CLOCK for 5s, icon indicating hour will flash. Press this button again, icon indicating minute will flash. ▲ And ▼ are used to adjust the figure. Setting or modification is effective only by pressing OK button to make confirmation.
- Lock: The icon will be lightened or off when pressing LOCK. In locked state, all the buttons are ineffective except button LOCK.
- Time ON/OFF: In the state of time ON, icon ON will be lightened, which is the same to the state of time OFF. Setting timer ON and OFF simultaneously, both icons ON and OFF are displayed.

- Fan speed: Press FAN SPEED to display the current wind speed. AUTO, LOW, MED and HIGH can be selected. The default state is high fan speed for the unit without medium fan speed.
- Economic operation: This icon will be lightened or off when pressing ECO button.

**NOTE: All the above icons will be displayed only when the remote controller is electrified for the first time or reset.**

## OPERATION INSTRUCTIONS

### Install and replace batteries

- Install 2 pieces of 7# alkaline batteries.
- Slide the cover to install batteries and make sure to place them in right pole.

### AUTO operation

Switch on the power and running indicator light on indoor unit flashes.

- Press MODE to select AUTO.
- Adjust temp via ▲ and ▼ . Generally the range is 17°C~30°C.
- Press ON/OFF and running indicator light on indoor unit is lightened. Air conditioner will work on AUTO mode and fan speed is AUTO which is nonadjustable.
- ECO is effective on AUTO operation.

### COOL/HEAT/FAN operation

- Press MODE to select COOL, HEAT or FAN.
- Adjust temp via ▲ and ▼ . Generally the range is 17°C~30°C.
- Press FAN SPEED to select AUTO, LOW, MED or HIGH.
- Press ON/OFF and running indicator light on indoor unit is lightened. Air conditioner will work on the set mode. Stop operation via ON/OFF.

NOTE: On FAN mode, temp is nonadjustable and ECO is ineffective. Procedure 2 is omitted.

#### **DRY operation**

1. Press MODE to select DRY.
2. Adjust temp via ▲ and ▼ . Generally the range is 17 °C~30 °C.
3. Press ON/OFF and running indicator light on indoor unit is lightened. Air conditioner will work on DRY mode. Turn off the unit via ON/OFF.
4. On DRY mode, ECO and FAN SPEED are unavailable.

#### **Timer operation**

TIMER ON and TIMER OFF are used to turn on and turn off the unit at the set time respectively.

#### **TIME ON operation**

1. Press TIMER ON, icon SET, HOUR and ON are lightened.
2. Press TIMER ON again and adjust the time.
3. Keep pressing this button, the time will increase by 0.5 hour. When the set time exceeds 10 hours, pressing the button will increase the time by 1 hour.
4. 0.5s after setting, remote controller will send TIME ON command to the unit.

#### **TIME OFF operation**

1. Press TIME OFF, icon SET, HOUR and OFF are lightened.
2. Press TIME OFF again and adjust the time.
3. Keep pressing this button, the time will increase by 0.5 hour. When the set time exceeds 10 hours, pressing the button will increase the time by 1 hour.
4. 0.5s after setting, remote controller will send TIME OFF command to the unit.

#### **Set TIME ON and TIME OFF simultaneously**

1. Set TIME ON according to procedures 1 and 2 specified in **TIME ON operation**.
2. Set TIME OFF as the procedures 1 and 2 specified in **TIME OFF operation**.
3. If both the set time of TIME ON and TIME OFF not exceed 10 hours, time OFF operation will activated 0.5 hour later than time ON operation. If both the set time of TIME ON and TIME OFF exceed 10 hours, time OFF operation will be activated 1 hour later than time ON operation.
4. 0.5s after setting, remote controller will send TIME ON command to the unit.

#### **Modification of timer operation**

Press corresponding button and readjust the time of time ON and time OFF. Adjust the time figure to 0.00 to cancel the timer operation.

**NOTE: The time set in timer operation is the relative figure based on the clock on remote controller. Adjusting clock is unavailable when TIME ON or TIME OFF is activated.**

R05/BGE-20

# Decommissioning

## Disconnecting

Only authorised personnel must disconnect the unit.

Avoid leak or spills into the environment.

Before disconnecting the unit, the following must be recovered, if present:

- refrigerant gas
- anti-freeze solutions in the water circuit

Awaiting dismantling and disposal, the unit can also be stored outdoors, if the electrical, cooling and water circuits of the unit have 100% integrity and are isolated, bad weather and rapid change in temperature will not result in any environmental impact.

## Dismantling and disposal

The unit must always be sent to authorised centres for dismantling and disposal.

When dismantling the unit, the fan, the motor and the coil, if operating, may be recovered by the specialist centres for reuse.

All the materials must be recovered or disposed of in compliance with the corresponding national standards in force.

For further information on the decommissioning of the unit, contact the manufacturer.

## Directive EC RAEE

The manufacturer is registered on the EEE National Register, in compliance with implementation of Directive 2012/19/EU and relevant national regulations on waste electrical and electronic equipment.

This Directive requires electrical and electronic equipment to be disposed of properly.

Equipment bearing the crossed-out wheelee bin mark must be disposed of separately at the end of its life cycle to prevent damage to human health and to the environment.

Electrical and electronic equipment must be disposed of together with all of its parts.

To dispose of "household" electrical and electronic equipment, the manufacturer recommends you contact an authorised dealer or an authorised ecological area.

"Professional" electrical and electronic equipment must be disposed of by authorised personnel through established waste disposal authorities around the country.

In this regard, here is the definition of household WEEE and professional WEEE:

WEEE from private households: WEEE originating from private households and WEEE which comes from commercial, industrial, institutional and other sources which, because of its nature and quantity, is similar to that from private households. Subject to the nature and quantity, where the waste from EEE was likely to have been by both a private household and users of other than private households, it will be classed as private household WEEE;

Professional WEEE: all WEEE which comes from users other than private households.

This equipment may contain:

- refrigerant gas, the entire contents of which must be recovered in suitable containers by specialised personnel with the necessary qualifications;
- lubrication oil contained in compressors and in the cooling circuit to be collected;
- mixtures with antifreeze in the water circuit, the contents of which are to be collected;
- mechanical and electrical parts to be separated and disposed of as authorised.

When machine components to be replaced for maintenance purposes are removed or when the entire unit reaches the end of its life and needs to be removed from the installation, waste should be separated by its nature and disposed of by authorised personnel at existing collection centres.



FOR OVER 30 YEARS, WE HAVE BEEN  
OFFERING SOLUTIONS TO ENSURE  
SUSTAINABLE COMFORT AND THE WELL-  
BEING OF PEOPLE AND THE ENVIRONMENT



sales and assistance

[www.clivet.com](http://www.clivet.com)

**MideaGroup**  
*humanizing technology*



**CLIVET S.p.A.**

Via Camp Lonc 25, Z.I. Villapaiera  
32032 Feltre (BL) - Italy  
Tel. +39 0439 3131 - [info@clivet.it](mailto:info@clivet.it)

**CLIVET GMBH**

Hummelsbütteler Steindamm 84,  
22851 Norderstedt, Germany  
Tel. +49 40 325957-0 - [info.de@clivet.com](mailto:info.de@clivet.com)

**Clivet Group UK LTD**

Units F5 & F6 Railway Triangle,  
Portsmouth, Hampshire PO6 1TG  
Tel. +44 02392 381235 -  
[Enquiries@Clivetgroup.co.uk](mailto:Enquiries@Clivetgroup.co.uk)

**CLIVET LLC**

Office 508-511, Elektroavodskaya st. 24,  
Moscow, Russian Federation, 107023  
Tel. +7495 6462009 - [info.ru@clivet.com](mailto:info.ru@clivet.com)

**CLIVET MIDEAST FZCO**

Dubai Silicon Oasis (DSO) Headquarter Building,  
Office EG-05, P.O Box-342009, Dubai, UAE  
Tel. +9714 3208499 - [info@clivet.ae](mailto:info@clivet.ae)

**Clivet South East Europe**

Jarušćica 9b  
10000, Zagreb, Croatia  
Tel. +385916065691 - [info.see@clivet.com](mailto:info.see@clivet.com)

**Clivet Airconditioning Systems Pvt Ltd**

Office No.501 & 502,5th Floor, Commercial -I,  
Kohinoor City, Old Premier Compound, Off LBS  
Marg, Kiroi Road, Kurla West, Mumbai  
Maharashtra 400070, India  
Tel. +91 22 30930200 - [sales.india@clivet.com](mailto:sales.india@clivet.com)