

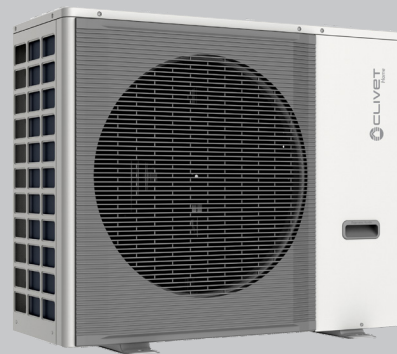

Two section air-water heat pump  
for heating, cooling and DHW  
production

## SPHERA EVO 2.0 Box SQKN-YEE 1 BC + MiSAN-YEE 1 S 2.1-8.1



TECHNICAL BULLETIN



SIZE	2.1	3.1	4.1	5.1	6.1	7.1	8.1
HEATING CAPACITY KW	4,32	6,18	8,30	10,9	12,13	14,51	16,01
COOLING CAPACITY KW	4,55	6,44	8,10	10,00	12,06	13,79	14,84

---

## Page

3	Features and benefits
4	Standard unit technical specifications
6	Built-in options
7	Accessories separately supplied
13	Hybrid version
16	General technical data
30	Refrigerant pipe connection
31	Collegamenti idraulici
32	Electrical connections
33	Fonti di calore ausiliarie e versioni ibride
37	System connections
41	Data for the UNI/TS 11300 calculation
46	Energy requalification
47	EuroSwitch Function
48	Dimensional drawings



Clivet is taking part in the EUROVENT certification programme up to 1,500 kW. The products concerned appear in the certified products list of the EUROVENT [www.eurovent-certification.com](http://www.eurovent-certification.com) site.

# Features and benefits

SPHERA EVO 2.0 is a specialised autonomous heat pump system for single- and multi-family homes with medium/low and high power consumption.

Is an air-water heat pump system for cooling and producing/storing domestic hot water.

The SPHERA EVO 2.0 system is composed of a latest generation high efficiency outdoors moto-condensing unit connected via refrigerant connections to an indoors unit.

It is the second generation of heat pumps for residential use.

## SPHERA EVO 2.0 Box

- Box Version
- Integrated 3-way valve for DHW
- Compact dimensions
- Class A+++ Low temperature
- Built-in WiFi for connection to the dedicated APP
- Also available in the hybrid version with 24 kW or 34 kW gas boiler



## SPHERA EVO 2.0 Tower

- Tower Version
- Two volumes of DHW 190 and 250-litres
- Class A++ Average temperature
- Class A+ Domestic hot water production
- Built-in WiFi for connection to the dedicated APP
- Also available in the hybrid version with 24 kW or 34 kW gas boiler

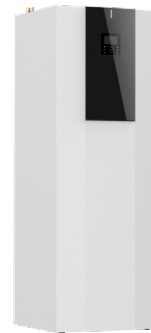

## SPHERA EVO 2.0 Invisible

- Version for built-in installation
- 50-litre DHW storage can be expanded up to 300-litres
- Compact dimensions for easy installation in walls
- Also available in the hybrid version with 24 kW gas boiler
- Built-in WiFi for connection to the dedicated APP



## SPHERA EVO 2.0 - BOX - Indoor unit

### Zinc-Magnesium frame

Supporting frame in Zinc-Magnesium panelling, excellent mechanical characteristics and high resistance to corrosion over time.

### Panelling

External panelling in zinc-magnesium sheet, with white paint in RAL 9003 to ensure better resistance to corrosion. Panels that can be easily removed to allow full access to internal components.

### Internal exchanger

Direct expansion heat exchanger with INOX AISI 316 stainless steel braze-welded plates. With low refrigerant content and high exchange surface, complete with external anti-condensation thermal insulation 10 mm thick in sintered expanded polypropylene.

### Hydronics module

- DC primary circulate pump, vary at variable flow
- Safety flow switch for water flow
- 3-way switching valve of installation or domestic hot water
- Water side safety valve 3bar
- Magnetic dirt separator
- Systeem purge valve
- 8 liter system expansion tank, 1 bar pre-charge
- ABS drain pan

### Electrical panel

The electrical panel is located inside the unit and is easily accessible thanks to removable panel. Moreover, a LED on the front panel is connected to check the operating status of the unit.

The capacity section includes:

- main power supply terminals.

The control section includes:

- remote microprocessor control with single-area thermostat function;
- BMS management;
- daily, weekly temperature set point and start-up/shutdown scheduler;
- anti-legionella function scheduling;
- management busters two zones;
- solar thermal management;
- management for auxiliary heaters;
- antifreeze protection water side;
- no water flow-rate protection with flow switch;
- remote interface terminal with graphic display;
- cascade operation.

Inside the electrical panel there are:

- T5 temperature probe for temperature control in DHW storage tanks (length 4.5m and 6mm bulb);
- T1B temperature probe for low temperature area control in the 2 area kit (length 4.5m and 6mm bulb);
- T1 temperature probe for external boiler connection kit (1.6m length and 6mm bulb).
- Wi-Fi per connessione all'APP dedicata alla gestione dell'unità.

The immersion heater in the DHW storage tanks must not exceed 4 kW.

### Standard unit kit:

- Mesh filter for system water
- Copper gas reduction for 4-6 kW external unit connection
- Unit connection fittings
- Key and torx insert for opening and closing unit panels
- Cover cap for remotely controlled keypad

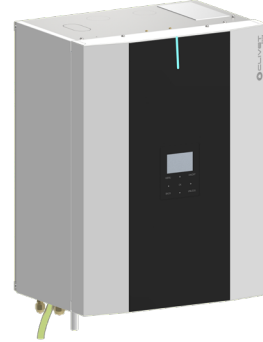

# Standard unit technical specifications

## SPHERA EVO 2.0 - Outdoor unit

### Zinc-Magnesium frame

High strength frame for outstanding durability and excellent mechanical characteristics.

### Panelling

Outer panelling made of Zinc-Magnesium sheet metal painted with pantone warm gray 2C to ensure superior corrosion resistance. Each panel can be easily removed to allow full access to internal components.

### Rotary DC inverter compressor

Inverter controlled rotary hermetic compressor for constant modulation of the power supplied according to actual needs, ensuring high seasonal efficiency. With a motor protection device for overheating, overcurrents and excessive temperatures of the supply gas. It is installed on anti-vibration mounts and it is equipped with oil charge. The compressor is wrapped by a sound-absorbing hood, that reduces its sound emissions. A guard heater with automatic insertion prevents the refrigerant from diluting the oil when the compressor stops.

### EC inverter fan

Axial fan with variable speed control and sickle shaped blades in ABS resin. It is directly coupled to the electronically controlled motor (IP23), which, thanks to brushless technology and the particular power supply, increases its lifespan and reduces consumption. The fan is housed in an aerodynamically shaped nozzle to increase efficiency and minimise noise. It is also fitted with anti-intrusion grid.

### External exchanger

Direct expansion finned coil exchanger made with copper pipes mechanically expanded to better adhere to the fin collar. It has a large surface area to improve heat exchange and reduce defrosting in the interest of seasonal efficiency. The fins are made of aluminium with hydrophilic treatment which facilitates the elimination of condensate, further improving defrosting.

### Refrigerant circuit

The refrigeration circuit includes:

- Electronic expansion valve
- 4-way cycle inversion valve
- Liquid separator in extraction
- Mechanical filters
- Low pressure pressure switch
- High pressure pressure switch

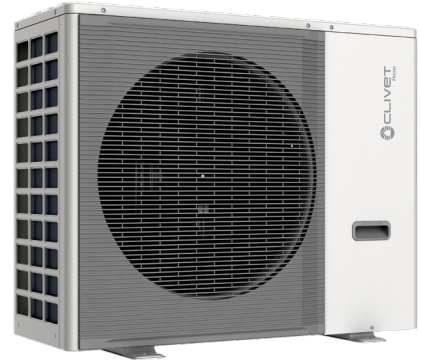

## **EH024 Integration electric heater**

**EH3** Integration electric heater in STAINLESS STEEL with 2-3 and 4 kW single-phase or 6-9 kW three-phase capacities.

**EH6**  
**EH9**

The electric heater can operate both for the system and for the production of domestic hot water in two different modes:

- as an integration, when the heat pump capacity is not enough to fulfil the required set point;
- as a safety element if the heat pump fails;

⚠ The additional electric heater is not an accessory supplied separately, but a construction configuration.

⚠ The configuration with additional electric heater excludes the external boiler connection kit.

⚠ Selection of the additional three-phase electric heater changes the voltage of the indoor unit only. The outdoor unit remains with single phase power supply.



## **1PUM Single pump with larger available head**

Configuration involving a pump with a head higher than the standard one.

The circulator, with a head of 10.5 m and a direct current power supply, has a variable flow rate and adapts perfectly to the internal logic of the unit.

⚠ Single pump with increased head is not an accessory supplied separately, but a construction configuration.



# Accessories separately supplied

**KIRE2HX - 2 zones: external kit, high temperature**  
**KIRE2HLX 2 zones: external kit, high temperature + low temperature**

Distribution module for 2-zone heating systems with compact design (402 mm x 250 mm x h525 mm) and ample versatility for different types of installation.

Kit composed of:

- 1 collector / Black painted separator;
- 2 circulator;
- 1 sliding temperature mixing valve (only for the kit KIRE2HL);
- 1 EPP insulation (front and rear);
- 1 threaded disc with hermetic sealing cap,
- 1 lower anti-rotation jig;
- 1 support bracket module.

For the technical data of the hydraulic head of the pumps, please refer to the dedicated section in the HYDRAULIC DATA chapter.

**KCSX Secondary circuit kit (1-litre circuit breaker + pump)**

The single-zone kit consists of a DIX hydraulic separator combined with a high efficiency pump, all inside a box for easy installation. Allows interaction between the primary circuit circulator and the secondary circuit circulator. Furthermore, the separator also has the function of a deaerator. With the following benefits and advantages:

- makes the connected hydraulic circuits independent;
- ensures effective operation of the secondary circulator that provides the hydraulic demand of air conditioning systems
- air extraction system;
- thermally insulated black EPP
- zone manifold connection kit

The kit is comprised of:

- 1 1-litre circuit breaker;
- 2 copper pipes;
- 1 circulator;
- closing plates



Dimensions:  
Length 457 mm  
Height 457 mm  
Depth 133 mm

## DIMENSIONAL

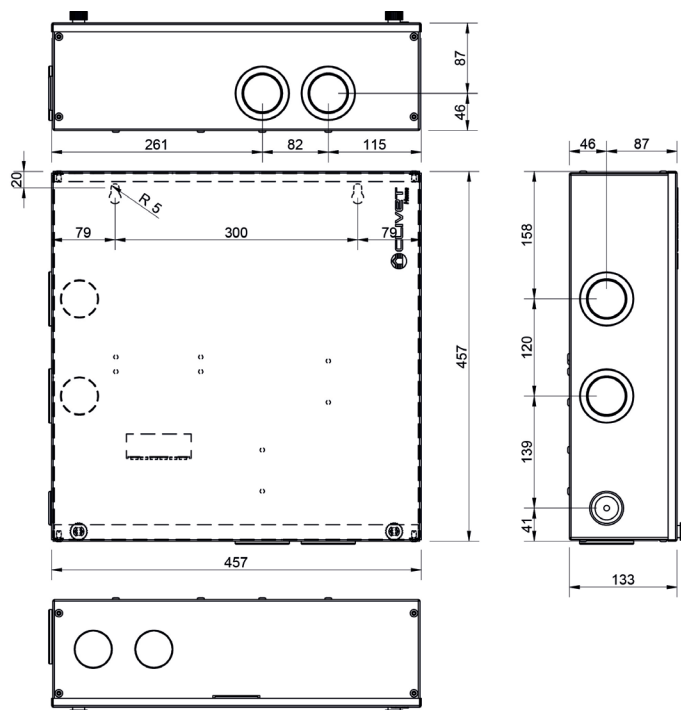

## DIX 1 I hydraulic circuit breaker

The CP60 hydraulic separator is a compensation chamber designed to make connected hydraulic circuits independent. It is used when the circulator of the primary circuit interacts with one or more parts of the secondary circuit in the same system. Furthermore, the separator performs the function of a deaerator.

With the following benefits and advantages:

- makes the connected hydraulic circuits independent;
- ensures effective operation of the secondary circulators that provide the hydraulic demand of air conditioning systems
- air extraction system;
- thermally insulated black EPP
- zone manifold connection kit

Technical data:

Nominal diameter DN 20

Connection 1" F

Max overall dimensions 120 x 420 x 945

Max temperature 110°C

Max pressure 6 bar

Circuit breaker material S235 steel

Insulation material EPP (40 g/l)

Insulation thickness 20 mm

The kit is supplied with a plate for wall mounting



## DIMENSIONAL

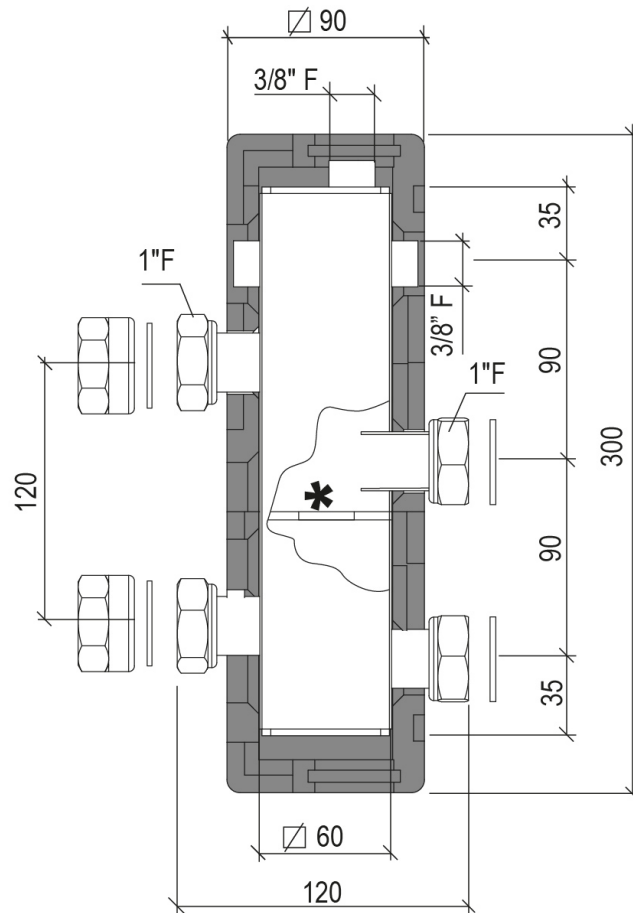



# Accessories separately supplied

## DI50X

### 50-litre circuit breaker

Technical 50-litre storage tank with the function of a hydraulic separator and inertial tank ensures effective operation of the secondary circulators that provide the hydraulic demand of air conditioning systems. With the possibility of connecting two zones.

Technical data:

Circuit breaker diameter 380 mm

Circuit breaker height 933 mm

Connections 1"1/4 F

Max temperature 95°C

Max pressure 6 bar

Circuit breaker material S235JR steel

Circuit breaker capacity 57 litres

Circuit breaker weight 25 kg

Insulation material Polyurethane foam

Insulation thickness 40 mm

Energy class B

Specific heat loss 0.76 W/K

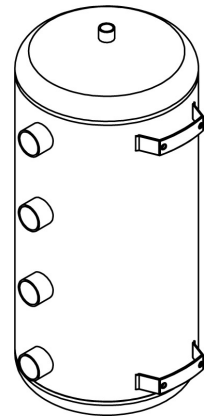

The kit is supplied with brackets for wall mounting.

## DIMENSIONAL

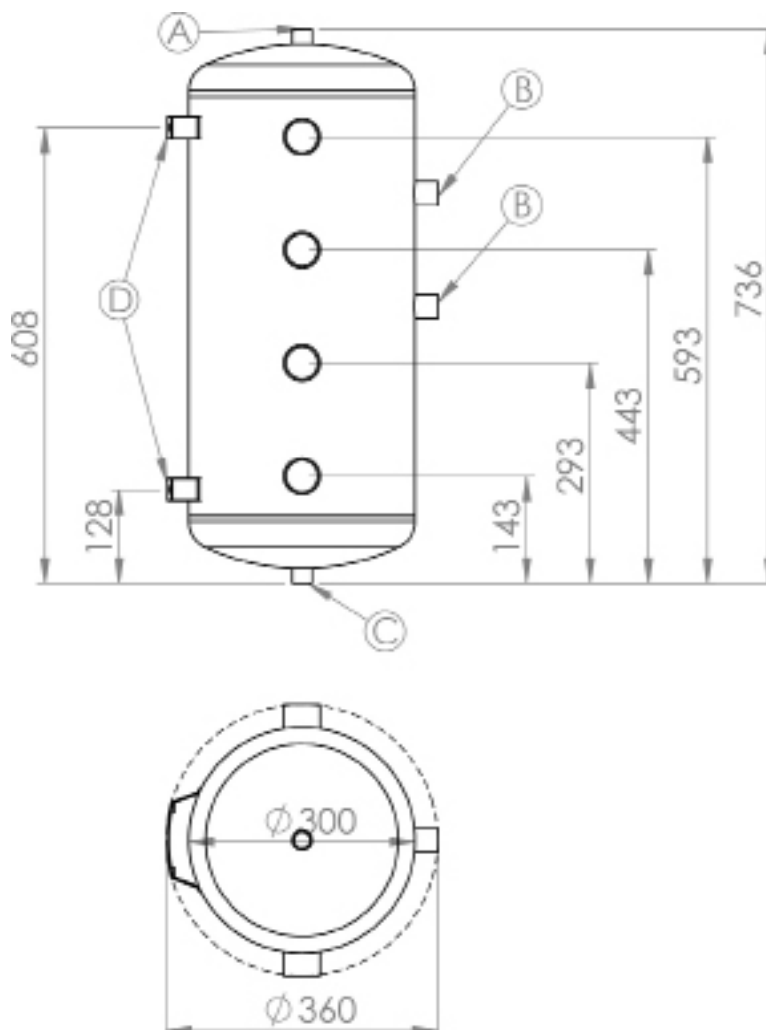

**ACS200X 200-liter domestic hot water storage tank**  
**ACS300X 300-liter domestic hot water storage tank**  
**ACS500X 500-liter domestic hot water storage tank**

Carbon steel tanks with internal vitrification treatment according to DIN 4753-3 and UNI 10025. Complete with magnesium anodic protection, inspection flange, electric heater.

All the tanks have an external insulation in 70 mm rigid polyurethane which allows to reduce heat losses to a minimum and increase efficiency.

		ACS200X	ACS300X	ACS500X
Capacity	[litri]	196	273	475
Diameter	[mm]	640	640	790
Height	[mm]	1215	1615	1705
Surface of exchanger	[m <sup>2</sup> ]	1,5	1,8	2,2
Surface of solar exchanger	[m <sup>2</sup> ]	\	\	\
Max pressure of hot water	[bar]	10	10	10
Tank energy class	[-]	B	B	B
Storage dispersion	[W]	51	63	80
Thermal dispersions	[W/K]	1,13	1,40	1,78
Electric heater	[kW]	2,0	2,0	2,0

Data according to DIN 4708 / EN 12897 / en 15332

**SCS08X 0.8 m<sup>2</sup> solar exchanger for flange installation**  
**SCS12X 1.2 m<sup>2</sup> solar exchanger for flange installation**

The kit is available in two sizes: 0.8 m<sup>2</sup> when combined with the 200 and 300 litre tank and 1.2 m<sup>2</sup> when combined with the 500 litre tank.

The kit is comprised of:

- tin-plated finned copper coil
- plastic cover

**ACI40X 40L system inertial storage tank**

Inertial storage tank to be installed outside the unit. Extremely compact, supplied with air vents and support brackets for wall installation. Suitable for all SPHERA EVO 2.0 sizes, it facilitates operation and helps to fulfil the heat requirement, guaranteeing optimal modulation.

It can be installed next to or behind the unit, as shown in the figure.

Kit consisting of:

- 1 40-litre ST37.1 steel storage tank for ACI40X
- 1 2-metre flexible hose
- Extremely compact:  
 LENGTH: 440 mm  
 DEPTH: 220 mm  
 HEIGHT: 887 mm
- Maximum working temperature: 100°C
- Maximum operating pressure: 6 bar
- Thermally-isolated with EPP 40 g/l
- Insulation thickness 30 mm
- Automatic air vent



**KCCEX External boiler connection kit**

Kit offering the option to connect the water circuit to an external boiler.

The latter, to be provided by the customer, must have a clean ON/OFF contact.

The internal logics of SPHERA EVO 2.0 permit use of the boiler both together with or instead of the heat pump for greater comfort even at the coldest temperatures.

Kit composed of:

- 1 three-way valve with microswitch for ON/OFF activation of the boiler;
- copper pipes for connection;
- plastic seals;
- terminals and cables for electrical connections;
- kit installation manual.

- ⚠ The external boiler connection kit excludes configuration with additional electric heater.
- ⚠ Check that the boiler pressure drops are compatible with the head of the unit.
- ⚠ Not required for SPHERA EVO 2.0 BOX Hybrid version

# Accessories separately supplied

**HID-TCXB**    **Black soft touch chronothermostat, with temperature control and management via App / Voice control**  
**HID-TCXN**    **White soft touch chronothermostat, with temperature control and management via App / Voice control**

For semi-uncased installation

Main functions available from the thermostat:

- ON/OFF
- keypad lock
- set-point control and limitation
- room temperature display
- setting change (manual / scheduled)
- antifreeze function (prevents temperatures that are too low)

Additional functions available on the Clivet Home Connect App

- weekly schedule
- boost (forced system switch-on)
- temperature and consumptions log

Technical specifications:

- display: colour soft-touch
- combinable SwitchConnect receivers: max 2
- installation: semi-uncased
- power supply: 100÷253V / 50÷60Hz
- settable temperature: 5÷40°C
- antifreeze temperature: 2÷25°C
- temperature offset: ±5°C (std 0°C)
- protection rating: IP30
- Wi-Fi: 802.11 b/g/n
- self-adjusting clock via web with back-up battery
- dimensions: 122x82x15mm



## **SWCX**    **SwitchConnect radio receiver**

Radio receiver for HID-TConnect, for managing the request of terminal units or radiant systems, the heat pump mode change or the double set-point.

Technical specifications:

- functions: radio receiver for use with HID-TConnect
- combinable thermostats: max 6
- frequency: 2.4GHz
- transmission distance: max 30m (in buildings) / max 100m (in open range)
- contacts: 2 relays (voltage-free)
- power supply: 95÷290V / 47÷440Hz
- operation temperature: 0÷40°C
- operation humidity: 20÷80% RH
- dimensions: 125x78x30.5mm



## **T1BX**    **DHW temperature probe and additional heating source at 10 m** **T1B30X**    **DHW temperature probe and additional heating source at 30 m**

NTC water temperature probe with 10 m or 30 m cable.

The probe can be used to detect temperatures:

- Tsolar: solar thermal circuit
- T1: boiler or external electric heater
- T5: DHW tank
- Tw2: mixed zone 2
- Tbt1/Tbt2: hydraulic separator

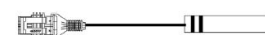

⚠ *The unit is equipped with a T1BX probe as standard.*

## DTX Auxiliary drain pan

### Outdoor unit

The base plate of the outdoor unit is fitted with a drain for the condensate produced during the winter phase in the defrosting period. This can help (not guarantee) condensate flow correctly into the relevant drains.

To ensure the condensate is drained correctly, in the various operating conditions it is mandatory to use the auxiliary condensate drain pan with drainage to be connected to the drain trap, according to the relevant technical standards and regulations in force.

An anti-freeze heater is also included in the drain pan. It prevents the condensate produced from freezing when the outdoor temperature drops below zero.



## APAVX Kit of antivibration mounts for floor installation

The antivibration mounts for floor installation reduce the vibrations of the compressor during its operation. They are secured to the feet of the base plate.



## ASTFX Kit of antivibration mounts for wall bracket installation

The antivibration mounts reduce the vibrations of the compressor during its operation. They are secured to the wall support brackets.



## KSIPX Kit with wall fixing brackets

Wall fixing bracket for outdoor unit, adjustable, in galvanised steel painted with polyester powders for outdoor use.



## VDACSX Thermostatic switching valve for DHW

The thermostatic switching valve is used in the DHW circuit.

It is designed to divert the water from the DHW storage tank directly to the utility as the water temperature is suitable for use. If the temperature is not adequate for direct use, the switching valve ensures the water passes inside the boiler which, thanks to instant production, guarantees continuous supply.

1 1/4 "M connections.

Body in anti-dezincification alloy. Chromium-plated.

PSU shutter.

Stainless steel springs.

EPDM sealing elements.

Maximum inlet temperature 100°C.

Adjustment range: 38÷52°C

Accuracy: ± 2°C

Max (static) working pressure: 10 bar

Max (dynamic) working pressure: 5 bar

Default calibration: 40°C

Minimum range for steady operation: 4 l/min



⚠️ Reductions for connections of different diameters are the responsibility of the client

# Hybrid version

Boiler to be combined with hybrid heat pump to form a system that can work together with the boiler, as a back-up for the heat pump. The logic of the heat pump controls all the boilers with an ON/OFF signal to ensure optimal operation of the system. The boilers can be used as standard with natural gas or LPG, depending on the type of supply available in the field.

The kit includes a condensing boiler and a 10-metre long temperature probe (T1) to be connected in the field.

⚠ *The hybrid version excludes the possibility of selecting electric heaters in the system*

## Stand-alone systems

### GAS BOILER\_UC / GAS BOILER\_FE 24.4-33.4 - 4-pipe condensing boiler for hybrid heat pumps

The boiler can produce DHW instantly, allowing the heat pump to work in heating or cooling mode at the same time.

For the FE version, the setpoint via 0-10V signal is controlled by the heat pump. Flue gas intake/discharge fittings can be connected to all versions of the boiler and are to be selected according to the required installation.

*Note: to work with LPG, the UC versions require a reducer (supplied as standard with the boiler) which is to be fitted on the nozzle in the field*



## Flue accessories for boilers

### KCSAFX

#### Vertical coaxial fitting $\varnothing$ 60/100mm

Vertical coaxial flanged polypropylene fitting, measuring 60/100mm in diameter, for the discharge of gas and intake of air for combustion via two coaxial ducts



### CCOAX

#### 90° coaxial elbow for $\varnothing$ 60/100 mm horizontal outlet that can be adjusted at 360°

Elbow for the discharge of gas and intake of air, that can be combined with  $\varnothing$  60/100 coaxial pipe with terminal.

The internal section is used for the discharge of the combustion gas while the external section is used for the intake of combustion air.



### TCOAX

#### Coaxial pipe L = 1000mm $\varnothing$ 60/100 with terminal

Pipe for flue gas discharge and air intake through an external wall, with discharge terminal

The internal section is used for the discharge of the combustion gas while the external section is used for the intake of combustion air.



### KAS80X

#### $\varnothing$ 80 mm vertical fittings

Two vertical flanged polypropylene fittings, 80 mm diameter, with inspection ports, which allow the combustion gas discharge and air intake to be split directly from the boiler body

⚠ *Only compatible with GAS BOILER UC 24.4-33.4*



### KSDFX

#### $\varnothing$ 80mm flue gas splitter kit

Polypropylene kit to split the air intake and the flue gas discharge into two 80 mm connections with inspection ports to connect to vertical or bent pipes

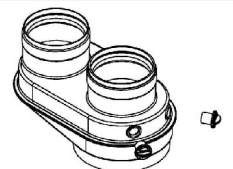

## Centralized systems

### **GAS BOILER\_UC 70.2-115.2-200F.2 - 2-pipe condensing boiler for hybrid heat pumps**

All the versions use the 0-10V signal of the heat pump to control the set-point, and version 200F.2 also uses Modbus communication.  
The 70.2 and 115.2 versions are for wall installation, while the 200F.2 is for installation on a base.



### **INAILX**

#### **INAIL safety kit for installation of single boiler**

INAIL-approved 1/2" safety hydraulic kit including pressure gauge, pressure gauge holder, 2 inspection wells, 100 °C lockout thermostat, thermometer, safety pressure switch.

### **FH100X**

#### **ø 100 mm vertical flue gas terminal**

Discharge terminal for boilers for outdoor installation, with weather protection



### **HIDUCX**

#### **Remote control for UC 70.2-115.2 boilers**

Remote control to manage Heating/ACS parameters and display the operating parameters and alarms.

It also permits communication via Modbus

 Only compatible with GAS BOILER UC 70.2-115.2

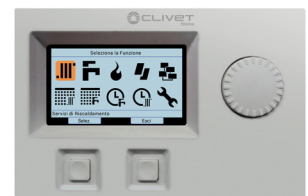

# Accessories separately supplied

## KISX

### Simplified installation kit with fittings for Sphera EVO Box Hybrid

The kit allows to facilitate the installation of the indoor unit and the boiler, making them a single element. As the hydraulic connections between the two are also included.

Technical data:

2 fixing brackets in painted steel

2 flexible hoses ( $\varnothing$  1")

2 1" F-F TEE fittings

1 1" water valve



### SQKN-YEE 1 BC Hybrid dimensional with installation kit

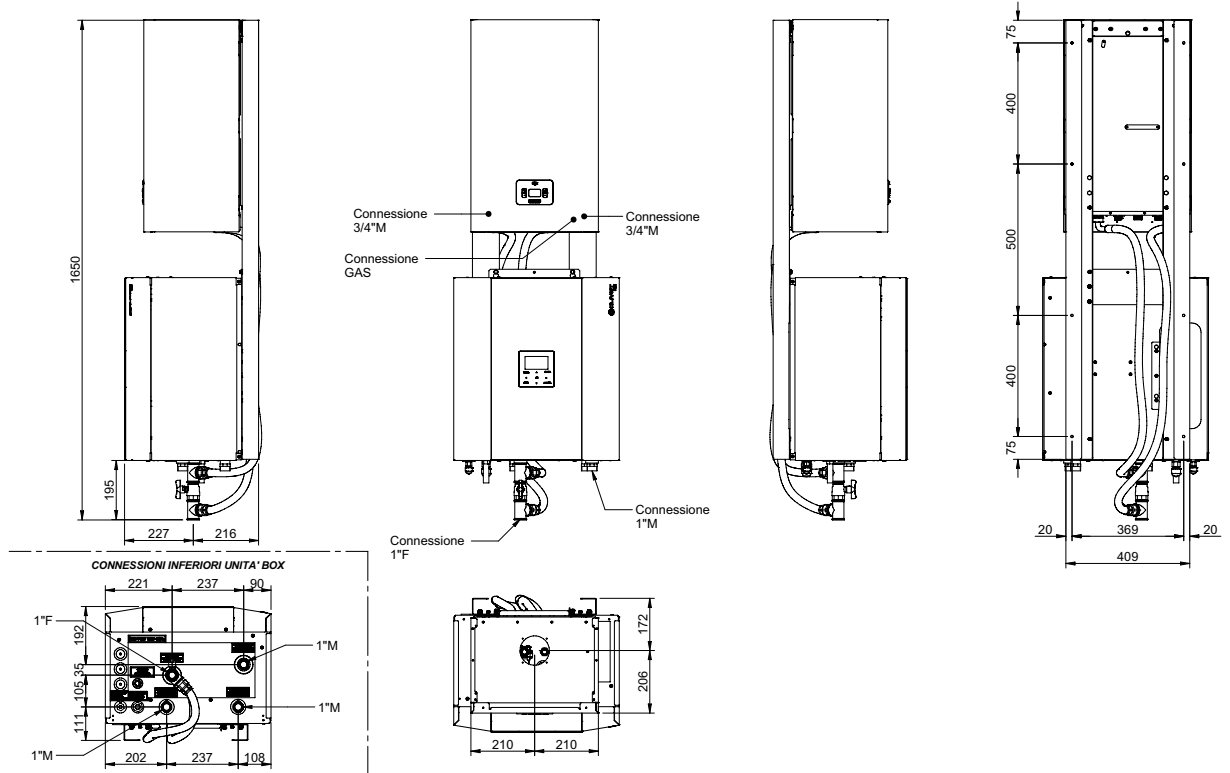

## Performance

SIZE			2.1	3.1	4.1	5.1	6.1*	7.1*	8.1*
<b>HEATING</b>									
<b>Air 7°C - Water 35°C</b>									
Nominal Heating capacity / Max	1	kW	4,32 / 6,26	6,18 / 7,41	8,30 / 9,11	10,09 / 10,3	12,13 / 14,60	14,51 / 15,5	16,01 / 16,80
Total power input	1	kW	0,80	1,19	1,56	2,01	2,42	3,09	3,52
COP	1	-	5,42	5,21	5,31	5,01	5,00	4,70	4,55
Water flow-rate	1	l/s	0,21	0,30	0,41	0,49	0,57	0,67	0,75
Nominal available pressure	1	kPa	31,2	36,5	33,1	31,0	25,7	31,7	22,6
Maximum available pressure	1	kPa	69 95	62 90	47 83	31 76	70	55	39
<b>Air -7°C - Water 35°C</b>									
Nominal Heating capacity / Max	2	kW	4,17 / 6,25	6,05 / 6,97	7,33 / 8,35	8,20 / 9,30	10,49 / 13,85	12,23 / 14,09	13,43 / 14,33
Total power input	2	kW	1,32	2,01	2,27	2,67	3,36	4,33	4,90
COP	2	-	3,16	3,00	3,23	3,07	3,13	2,82	2,74
Water flow-rate	2	l/s	0,22	0,29	0,34	0,40	0,56	0,62	0,70
Nominal available pressure	2	kPa	35,0	39,8	34,0	31,7	65,8	63,1	47,7
Maximum available pressure	2	kPa	69 94	64 91	58 88	49 84	71	63	49
<b>Air 7°C - Water 45°C</b>									
Nominal Heating capacity / Max	3	kW	4,16 / 5,96	6,03 / 7,13	8,22 / 8,98	10,01 / 10,30	12,30 / 14,50	14,00 / 15,70	16,01 / 16,60
Total power input	3	kW	1,06	1,57	2,08	2,59	3,24	3,84	4,45
COP	3	-	3,93	3,83	3,95	3,86	3,80	3,65	3,60
Water flow-rate	3	l/s	0,19	0,30	0,39	0,49	0,60	0,67	0,76
Nominal available pressure	3	kPa	32,3	36,4	34,9	31,0	51,6	41,8	21,7
Maximum available pressure	3	kPa	70 95	63 90	51 85	31 76	65	55	38
<b>Air 7°C - Water 55°C</b>									
Nominal Heating capacity / Max	4	kW	4,08 / 5,74	5,94 / 6,90	7,50 / 7,80	9,60 / 9,72	12,07 / 13,90	13,85 / 14,50	16,00 / 16,20
Total power input	4	kW	1,36	1,93	2,35	3,10	3,89	4,53	5,52
COP	4	-	3,00	3,07	3,19	3,10	3,10	3,05	2,90
Water flow-rate	4	l/s	0,12	0,18	0,23	0,29	0,36	0,41	0,48
Nominal available pressure	4	kPa	35,6	33,4	31,2	33,6	14,1	16,5	17,4
Maximum available pressure	4	kPa	70 98	70 96	69 94	63 91	90	105	80
<b>COOLING</b>									
<b>Air 35°C - Water 18°C</b>									
Nominal Cooling capacity / Max	5	kW	4,55 / 6,88	6,44 / 7,65	8,10 / 11,13	10,00 / 12,03	12,06 / 15,02	13,79 / 15,30	14,84 / 16,38
Total power input	5	kW	0,75	1,23	1,58	2,10	3,00	3,73	4,07
EER	5	-	6,08	5,24	5,12	4,77	4,02	3,70	3,65
Water flow-rate	5	l/s	0,22	0,32	0,38	0,48	0,60	0,63	0,71
Nominal available pressure	5	kPa	34,9	34,8	34,6	10,6	13,1	16,3	15,1
Maximum available pressure	5	kPa	69 94	61 89	51 85	32 76	65	61	48
<b>Air 35°C - Water 7°C</b>									
Nominal Cooling capacity / Max	6	kW	4,26 / 6,14	6,25 / 6,39	7,46 / 7,94	8,67 / 9,10	11,16 / 11,80	11,72 / 12,86	12,88 / 14,2
Total power input	6	kW	1,22	2,02	2,24	2,94	4,29	5,04	5,80
EER	6	-	3,50	3,09	3,33	3,09	2,75	2,55	2,45
Water flow-rate	6	l/s	0,20	0,29	0,36	0,43	0,54	0,59	0,64
Nominal available pressure	6	kPa	35,8	36,1	34,3	36,8	18,1	20,3	25,1
Maximum available pressure	6	kPa	70 95	64 91	56 87	43 82	74	67	60

1. User side entering/leaving water temperature 30/35°C, source side air 7°C (U.R. = 85% Heat power data, Total power input and COP in accordance with EN 14511:2018.
2. User side entering/leaving water temperature 30/35°C, source side air -7°C Heat power data, Total power input and COP in accordance with EN 14511:2018.
3. User side entering/leaving water temperature 40/45°C, source side air 7°C (U.R. = 85% Heat power data, Total power input and COP in accordance with EN 14511:2018.
4. User side entering/leaving water temperature 18/23°C, source side air 35°C Heat power data, Total power input and COP in accordance with EN 14511:2018.
5. User side entering/leaving water temperature 7/12°C, source side air 35°C Heat power data, Total power input and COP in accordance with EN 14511:2018.
6. The product is conforming with the European ErP Directives, which includes Commission Delegated Regulation (EU) N. 811/2018 and Commission Delegated Regulation N. 813/2013, Clima Average, High Temperature 47/55°C.

All data calculated with zero elevation gain and equivalent length of 7m..



# General technical data

SIZE			2.1	3.1	4.1	5.1	6.1*	7.1*	8.1*			
<b>ERP</b>												
<b>Clima Average High temperature Heat pumps</b>												
Nominal power	7	kW	4	6	7	9	12	13	13			
SCOP	7	-	3.32	3.54	3.72	3.73	3.56	3.52	3.48			
Generator energy class	7	-	A++	A++	A++	A++	A++	A++	A++			
$\eta_s$	7	%	130	138	146	146	139	138	136			
System energy class	7	-	A++	A++	A++	A++	A++	A++	A++			
$\eta_s$	7	%	135	143	151	151	144	143	141			
<b>Clima Average Low temperature Heat pumps</b>												
Nominal power	8	kW	5	6	8	10	12	14	16			
SCOP	8	-	5,13	5,15	5.32	5.27	5.00	4.91	4.89			
Generator energy class	8	-	A+++	A+++	A+++	A+++	A+++	A+++	A+++			
$\eta_s$	8	%	202	203	210	208	196	193	193			
System energy class	8	-	A+++	A+++	A+++	A+++	A+++	A+++	A+++			
$\eta_s$	8	%	207	208	215	213	201	198	198			
<b>Average climatic conditions - Heat pump for application with Fan coil</b>												
Nominal power	9	kW	4	6	7	9	12	13	14			
SEER	9	-	5,09	5,42	5.95	6.01	5.16	5.10	4.87			
Generator energy class	9	-	A+++	A+++	A+++	A+++	A+++	A+++	A+++			
$\eta_s$	9	%	201	214	235	238	203	201	192			
<b>Heat pump for Domestic Hot Water application</b>												
Load profile declared	10	-	L	XL	L	XL	L	XL	L	XL	XL	XL
$\eta_{wh}$	10	%	120	123	120	123	116	125	116	125	124	124
Sanitary water energy class	10	-	A+	A+	A+	A+	A+	A+	A+	A+	A+	A+

- The product is conforming with the European ErP Directives, which includes Commission Delegated Regulation (EU) N. 811/2018 and Commission Delegated Regulation N. 813/2013, Clima Average, Medium temperature 47/55°C
- The product is conforming with the European ErP Directives, which includes Commission Delegated Regulation (EU) N. 811/2018 and Commission Delegated Regulation N. 813/2013, Clima Average, Low temperature 30/35°C
- The product is conforming with the European ErP Directives, which includes Commission Delegated Regulation (EU) N. 811/2018 and Commission Delegated Regulation N. 813/2013, Clima Average, Low temperature 12/7°C
- Dati secondo EN 16147:2017

All data calculated with zero elevation gain and equivalent length of 7 m.

## Construction - Outdoor unit

SIZE			2.1	3.1	4.1	5.1	6.1	7.1	8.1
<b>Characteristics</b>									
Compressor	Twin Rotary								
Refrigerant	R32								
Refrigerant charge	kg	1.50	1.50	1.65	1.65	1.84	1.84	1.84	1.84
GWP	$t_{CO_2}$	675	675	675	675	675	675	675	675
Equivalent tons of CO2 (*)	$t_i$	1.02	1.02	1.11	1,11	1.24	1.24	1.24	1.24
Oil charge	l	0,46	0,46	0,46	0,46	1,10	1,10	1,10	1,10
Type of fan	Assiale								
Standard air flow rate	$m^3/h$	2770	2770	4030	4030	4060	4060	4060	4060
Outdoors unit sound pressure at 1 metre	1 dB(A)	42	44	45	47	50	51	53	53
Sound power	1 dB(A)	55	57	58	60	63	64	66	66
<b>Dimensions</b>									
Operation (L x P x A)	mm	986x426x712	986x426x712	1104x523x866	1104x523x866	1104x523x866	1104x523x866	1104x523x866	1104x523x866
Packaging (L x P x A)	mm	1065x485x800	1065x485x800	1180x560x890	1180x560x890	1180x560x890	1180x560x890	1180x560x890	1180x560x890
Operation weight 230M / 400TN	2 kg	58	58	77	77	96/112	96/112	96/112	96/112
Shipping weight 230M / 400TN	2 kg	64	64	88	88	110/125	110/125	110/125	110/125

- Sound pressure level determined using the intense metric method (UNI EN ISO 9614-2). Data referred to the following full load conditions: Heating - utility side water inlet/outlet 47/55°C, air source side 7°C. Cooling - utility side water inlet/outlet 12/7°C, air source side 35°C.
  - Power supply 220-240V ~ 50Hz / Power supply 380-415V 3N~ 50Hz.
- (\*) It contains fluorinated greenhouse gases.

## Construction - Indoor unit

SIZE			A	B
<b>Characteristics</b>				
Maximum system pressure		bar	3,0	3,0
System expansion tank	1	l	8,0	8,0
Preload expansion tank		bar	1,0	1,0
System water connections		inch	1"	1"
<b>Dimensions</b>				
Operation (L x P x A)		mm	547 x 386 x 604	547 x 386 x 604
Packaging (L x P x A)		mm	720 x 600 x 550	720 x 600 x 550
Operation weight		kg	50	53
Shipping weight		kg	58	61

1. Sufficient volume up to a maximum of 60 litres of system water content.

## Hydraulic data - Indoor unit + Outdoor unit

SIZE			2.1	3.1	4.1	5.1	6.1	7.1	8.1
			A	A	A	A	B	B	B
<b>Characteristics</b>									
Minimum system water content	1	l	40	40	40	40	40	40	40
Minimum water flow rate allowed		l/s	0,16	0,16	0,16	0,16	0,16	0,16	0,16
Maximum water flow rate allowed		l/s	0,61	0,61	0,61	0,61	0,92	0,92	0,92

1. Consider the water content of the area with less volume

## Configuration compatibility table SPHERA EVO 2.0 Box

INDOOR UNIT	SQKN-YEE 1 BC A		SQKN-YEE 1 BC A	SQKN-YEE 1 BC B	INTEGRATION ELECTRIC HEATER				
	Pump	Std	1PUM	STd	EH024	EH3	EH6	EH9	
<b>OUTDOOR UNIT</b>									
MiSAN-YEE 1 S 2.1		✓	✓	-	✓		✓	✓	
MiSAN-YEE 1 S 3.1		✓	✓	-	✓		✓	✓	
MiSAN-YEE 1 S 4.1		✓	✓	-	✓		✓	✓	
MiSAN-YEE 1 S 5.1		✓	✓	-	✓		✓	✓	
MiSAN-YEE 1 S 6.1		-	-	✓		✓	✓	✓	
MiSAN-YEE 1 S 7.1		-	-	✓		✓	✓	✓	
MiSAN-YEE 1 S 8.1		-	-	✓		✓	✓	✓	

# General technical data

## Condensing boiler technical data

MODEL				UC 24.4	UC 33.4	FE 24.4	FE 33.4
<b>Heating capacity</b>							
Nominal heating capacity (Qn)	-	Maximum	[kW]	24,0	34,0	24,5	34,8
		Minimum	[kW]	5,0	5,0	4,8	5,0
Heating capacity (Pn)	60/80°C	Maximum	[kW]	23,4	33,2	24,0	34,0
		Minimum	[kW]	4,8	4,8	4,7	4,9
	30/50°C	Maximum	[kW]	25,2	35,8	26,0	37,0
		Minimum	[kW]	5,3	5,4	5,2	5,4
Performance	60/80°C	Maximum	%	97,7	97,7	97,8	97,7
		Minimum	%	96,5	96,4	97,6	97,2
	30/50°C	Maximum	%	105,1	105,2	106,1	106,2
		Minimum	%	106,9	107,0	107,3	107,1
	30% di Pn	-	%	108,7	108,6	109,7	109,7
	Boiler water content	-	-	[l]	2,5	2,8	3,4
Operating pressure	PMS	Maximum	[bar]	3	3	3	3
	-	Minimum	[bar]	0,5	0,5	0,8	0,8
Expansion tank	Volume	-	[l]	10	10	8	10
	Preload	-	[bar]	1	1	0,8	0,8
<b>ACS performances</b>							
Nominal heating capacity (Qnw)	-	Maximum	[kW]	28,0	34,0	28,5	34,8
		Minimum	[kW]	5,0	5,0	4,7	5,0
Heating capacity	-	Maximum	[kW]	27,3	33,2	28,0	34,0
		Minimum	[kW]	4,8	4,8	4,7	4,8
Specific flow rate	ΔT=25°C	-	[l/min]	16,2	19,2	16,1	19,5
	ΔT=30°C	-	[l/min]	13,5	16,0	13,4	16,2
	ΔT=45 K	-	[l/min]	9,0	10,6	8,9	10,8
DHW production in continuous operation	ΔT=40 K	-	[l/min]	10,1	11,9	10,0	12,1
	ΔT=35 K	-	[l/min]	11,6	13,6	11,5	13,9
	ΔT=30 K	-	[l/min]	13,5	15,8	13,4	16,2
	ΔT=25 K	-	[l/min]	16,2	19,0	16,1	19,5
Water temperature		Maximum	[°C]	60	60	65	65
		Minimum	[°C]	38	38	40	40
Operating pressure	PMW	Maximum	[bar]	6	6	9	9
	-	Minimum	[bar]	0,5	0,5	0,3	0,3
<b>ErP data</b>							
Seasonal efficiency <i>Medium climate</i>	Heating	ηs	%	93	93	94	94
		Energy class	-	A	A	A	A
	DHW	ηwh	%	87	90	85	85
		Energy class	-	A	A	A	A
		DHW profile	-	XL	XL	XL	XXL
Sound power level		Lwa	[dB(A)]	53	56	49	52
<b>Thermal losses and smoke discharge</b>							
Chimney losses	"burner ON 80/60°C"	Pmax	%	2,33	2,27	2,00	2,10
		Pmin	%	2,24	2,32	2,00	2,90
	"burner ON 50/30°C"	Pmax	%	1,70	1,15	1,40	1,40
		Pmin	%	1,37	1,44	1,00	1,00
Smoke temperature	80/60°C	Pmax	[°C]	66,5	64,9	66	67
		Pmin	[°C]	64,3	65,9	64	62
	50/30°C	Pmax	[°C]	53,6	52,7	52	53
		Pmin	[°C]	47,2	48,4	44	45
Smoke flow rate	-	Pmax	[g/s]	13,8	15,6	11,2	16
	-	Pmin	[g/s]	2,3	2,3	2,3	2,4
Nitrogen oxide (NOX) emissions		Class	-	6	6	6	6
		-	[mg/kWh]	45	49	35	33

## Electrical data

### Outdoor unit

SIZE		2.1	3.1	4.1	5.1	6.1	7.1	8.1
<b>Power supply 220-240V ~ 50Hz</b>								
F.L.A. - Full load current at max admissible conditions	A	10.0	11.8	15.0	16.4	24.5	25.9	27.7
F.L.I. - Full load power input at max admissible conditions	kW	2.20	2.60	3.30	3.60	5.40	5.70	6.10
M.I.C - Maximum inrush current	A	10.0	11.8	16,7	16.4	24.5	25.9	27.7
<b>Power supply 380-415V 3N ~ 50Hz</b>								
F.L.A. - Full load current at max admissible conditions	A	-	-	-	-	8.20	8.70	9.30
F.L.I. - Full load power input at max admissible conditions	kW	-	-	-	-	5.40	5.70	6.10
M.I.C - Maximum inrush current	A	-	-	-	-	8.20	8.70	9.30

### Indoor unit

SIZE		A	B
<b>Power supply 220-240V ~ 50Hz</b>			
F.L.A. - Full load current at max admissible conditions	A	0,50	0,90
F.L.I. - Full load power input at max admissible conditions	kW	0,10	0,20
M.I.C - Maximum inrush current	A	0,50	0,90

Power supply 220-240V ~ 50Hz +/-10%

The units are conforming with the prescriptions of European Standards CEI EN 60335 and EN 60335-2-40

(\*) The electrical consumptions relating to the electric heater refer to that in the DHW storage tank.

**⚠ Important:** when rating the unit, check that the absorptions are conforming to the utility contract in the country of installation

### Unit configured with oversized pump

SIZE		1PUM
<b>Power supply 220-240V ~ 50Hz</b>		
F.L.A. - Current absorbed by the unit with increased head circulator	A	0,90
F.L.I. - Power input of the unit with increased head circulator	kW	0,20
M.I.C. - Unit maximum starting current of the unit with increased head circulator	A	0,90

Power supply 220-240V ~ 50Hz +/-10%

The units are conforming with the prescriptions of European Standards CEI EN 60335 and EN 60335-2-40

Data to be added to the values of the standard indoor unit.

### Integration electric heaters - EH024/EH3/EH6/EH9

SIZE		2 KW	3 KW	4 KW
<b>Power supply 220-240V ~50Hz</b>				
F.L.A. - Full load current at max admissible conditions	A	8,70	13,1	17,4
F.L.I. - Full load power input at max admissible conditions	kW	2,00	3,00	4,00

Power supply 220-240V ~50Hz +/- 10%

Size 2kW and 4kW available only for indoor unit A, size 3kW available only for indoor unit B

SIZE		6 kW	9 kW
<b>Power supply 380-415V 3N ~50Hz</b>			
F.L.A. - Full load current at max admissible conditions	A	8,60	13,0
F.L.I. - Full load power input at max admissible conditions	kW	6,00	9,00

Power supply 380-415V 3N ~50Hz +/- 6%

\*Data to be added to the values of the standard unit without DHW electric heater

**⚠** The additional electric heater is not an accessory supplied separately, but a construction configuration.

# General technical data

## External 2 zone kit

SIZE	KIRE2HX - KIRE2HLX	
<b>Power supply 220-240V ~50Hz</b>		
F.L.A. - Full load current at max admissible conditions	A	0,45
F.L.I. - Full load power input at max admissible conditions	kW	0,10

Power supply 220-240V ~ 50Hz +/-10%

The units are conforming with the prescriptions of European Standards CEI EN 60335 and EN 60335-2-40

Data to be added to the values of the standard indoor unit.

## Storage tanks for domestic hot water

SIZE		ACS200X	ACS300X	ACS500X
<b>Power supply 220-240V ~50Hz</b>				
F.L.A. - Current absorbed by the electric heater	A	8,70	8,70	8,70
F.L.I. - Power input of the electric heater	kW	2,00	2,00	2,00
M.I.C. Unit maximum starting current	A	8,70	8,70	8,70

Power supply 220-240V ~ 50Hz +/-10%

The units are conforming with the prescriptions of European Standards CEI EN 60335 and EN 60335-2-40

Data to be added to the values of the standard indoor unit.

The tanks are supplied with immersed electric heater.

## Auxiliary drain pan

SIZE	DTX	
<b>Power supply 220-240V ~50Hz</b>		
F.L.A. - Full load current at max admissible conditions	A	0,40
F.L.I. - Full load power input at max admissible conditions	kW	0,08

Power supply 220-240V ~ 50Hz +/-10%

The units are conforming with the prescriptions of European Standards CEI EN 60335 and EN 60335-2-40

Data to be added to the values of the standard indoor unit.

## Electrical data of the hybrid solution condensing boiler

MODEL		UC 24.4	UC 33.4	FE 24.4	FE 33.4
Power supply	[V-Hz]	230/50	230/50	230/50	230/50
F.L.A. - Full load current at max admissible conditions	- [A]	0,41	0,53	0,36	0,43
F.L.I. - Full load power input at max admissible conditions	- [kW]	0,095	0,122	0,082	0,099
Power supply fuse	-	3,15	3,15	3,15	3,15
Protection rating	IP	X5D	X5D	X4D	X4D

Power supply: +/-10%

The units comply with the requirements of European standards EN 60335-1 and EN 60335-2-40

Data to be added to standard indoor unit values.

## Sound levels outdoor unit

### Standard mode

SIZE	Sound power level								Sound pressure level	Sound power level
	Octave band (Hz)									
	63	125	250	500	1000	2000	4000	8000	dB(A)	dB(A)
2.1	46	49	49	52	52	46	37	27	42	55
3.1	49	48	50	55	53	48	39	30	44	57
4.1	36	51	53	56	55	49	44	30	45	58
5.1	37	56	53	57	57	51	47	36	47	60
6.1	44	53	54	60	58	55	52	51	50	63
7.1	44	54	55	60	59	57	56	54	51	64
8.1	46	58	57	60	61	59	54	51	53	66

Sound levels refer to units with full load under nominal test conditions. Data referred to the following conditions: entering / leaving exchanger water temperature user side 47/55°C source side exchanger air inlet 7°C.

The sound pressure level refers to a distance of 1m from the external surface of the units operating in an open field.

Noise levels are determined using the tensiometric method (UNI EN ISO 9614-2)

### Silenced mode

SIZE	Sound pressure level	Sound power level
	dB(A)	dB(A)
2.1	40	53
3.1	40	53
4.1	42	55
5.1	42	55
6.1	46	59
7.1	47	60
8.1	48	61

Sound levels refer to units with full load under nominal test conditions.

For maximum capacity delivered in silent mode use a correction factor of 0.8.

Data referred to the following conditions: entering / leaving exchanger water temperature user side 47/55°C source side exchanger air inlet 7°C.

The sound pressure level refers to a distance of 1m from the external surface of the units operating in an open field.

Noise levels are determined using the tensiometric method (UNI EN ISO 9614-2)

### Super-silenced mode

SIZE	Sound pressure level	Sound power level
	dB(A)	dB(A)
2.1	37	50
3.1	38	51
4.1	39	52
5.1	39	52
6.1	41	54
7.1	41	54
8.1	41	54

Sound levels refer to units with full load under nominal test conditions.

For maximum capacity delivered in silent mode use a correction factor of 0,6

Data referred to the following conditions: entering / leaving exchanger water temperature user side 47/55°C source side exchanger air inlet 7°C.

The sound pressure level refers to a distance of 1m from the external surface of the units operating in an open field.

Noise levels are determined using the tensiometric method (UNI EN ISO 9614-2)

## Operating limits

### Cooling

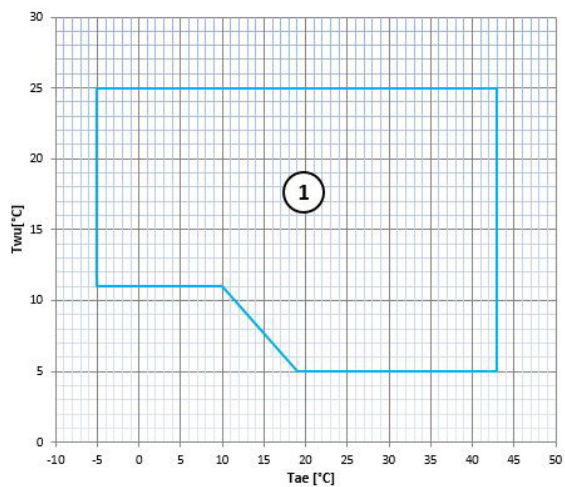

T<sub>wu</sub> [°C] = Exchanger water outlet temperature  
 T<sub>ae</sub> [°C] = Outdoors exchanger air inlet temperature

1. Normal operating range

### Heating

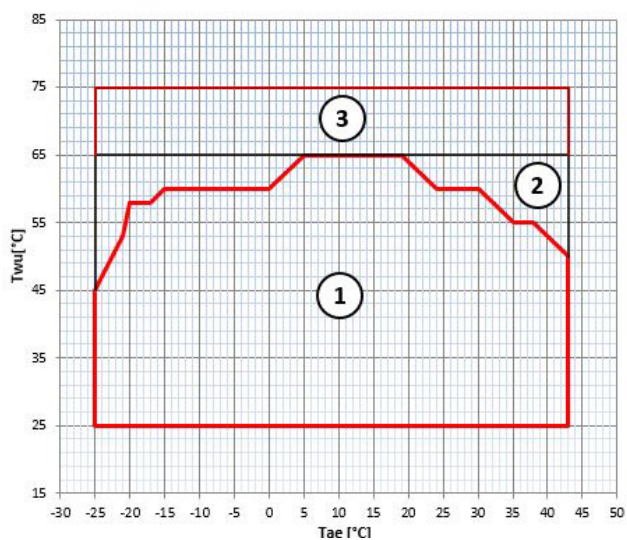

T<sub>wu</sub> [°C] = Exchanger water outlet temperature  
 T<sub>ae</sub> [°C] = Outdoors exchanger air inlet temperature

1. Normal operating range
2. Operating range with additional electric heater option
3. Hybrid system operating range

In the configuration with the integration electric heater, the extension of the limits varies according to the electrical capacity of the electric heater chosen.

## Available pressure of the standard circulator at the unit A connections

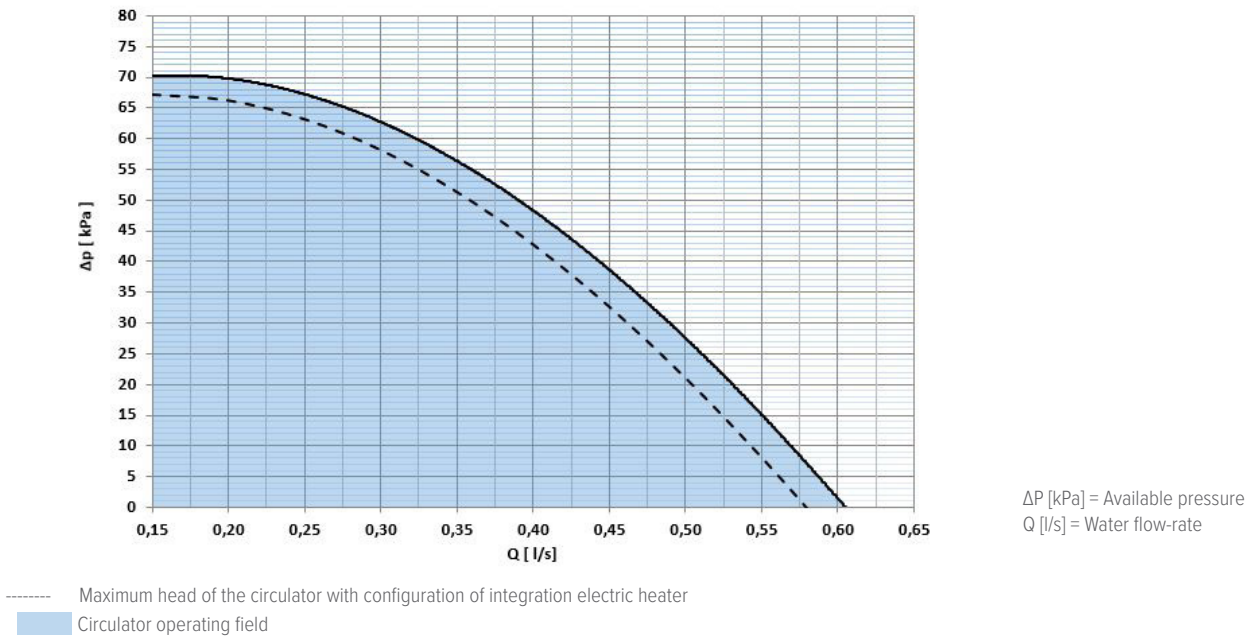

## Absorption of the standard circulator at the unit 190 L A

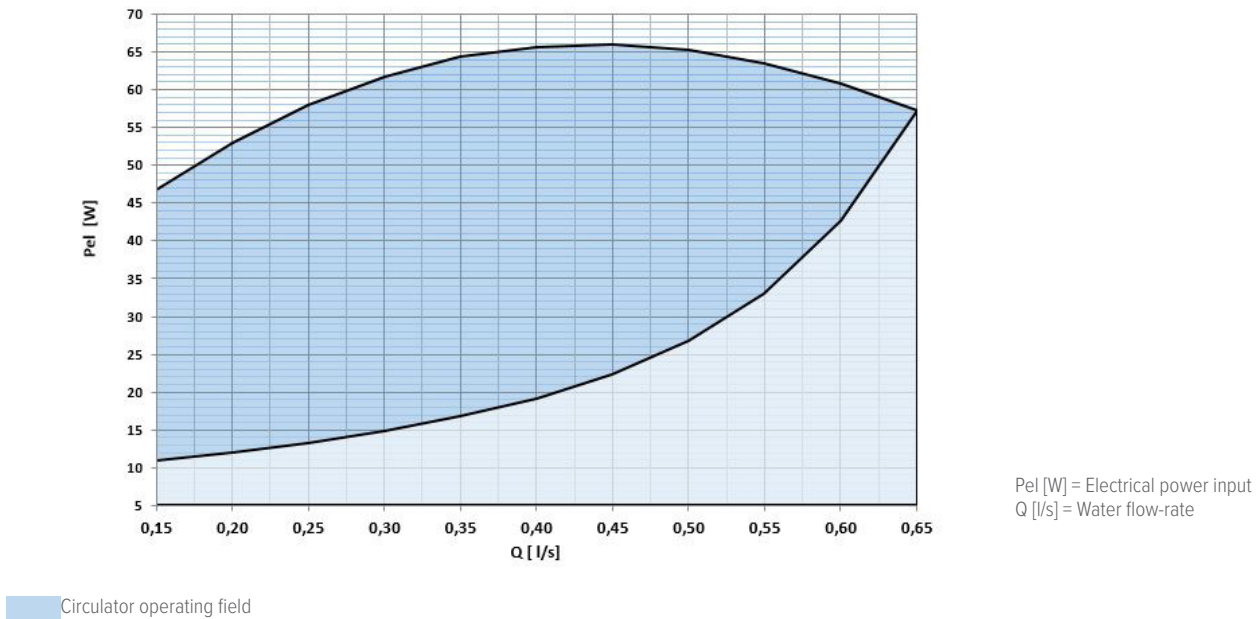



# General technical data

## Head of the circulator with increased pump at the unit A connections

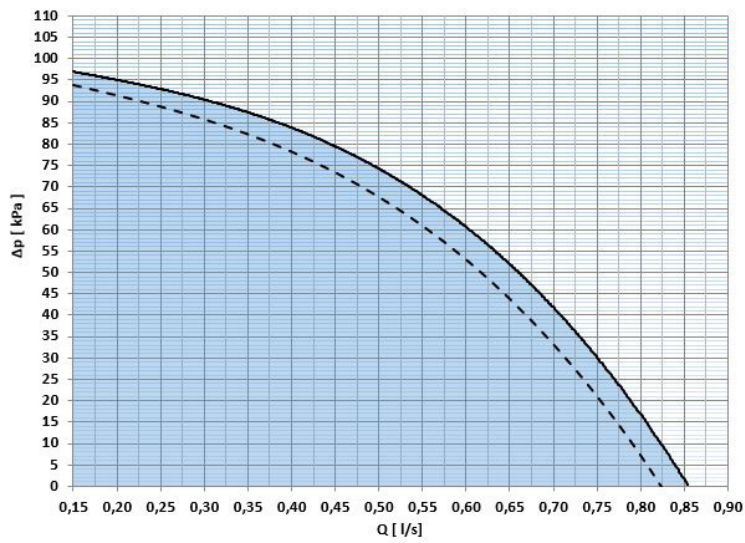

$\Delta P$  [kPa] = Available pressure  
 $Q$  [l/s] = Water flow-rate

----- Maximum head of the circulator with configuration of integration electric heater

■ Circulator operating field

## Absorption of the circulator increased at the unit 250 L A

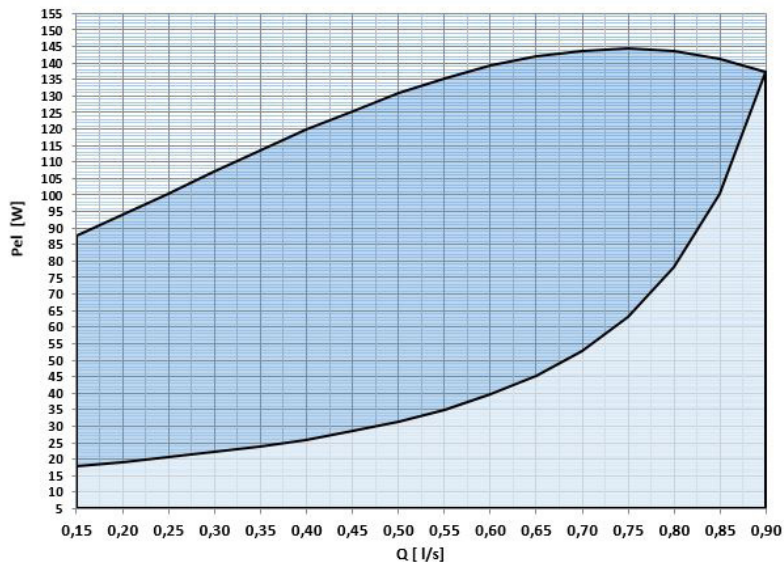

$P_{el}$  [W] = Electrical power input  
 $Q$  [l/s] = Water flow-rate

■ Circulator operating field

## Head of the circulator with increased pump at the unit B connections

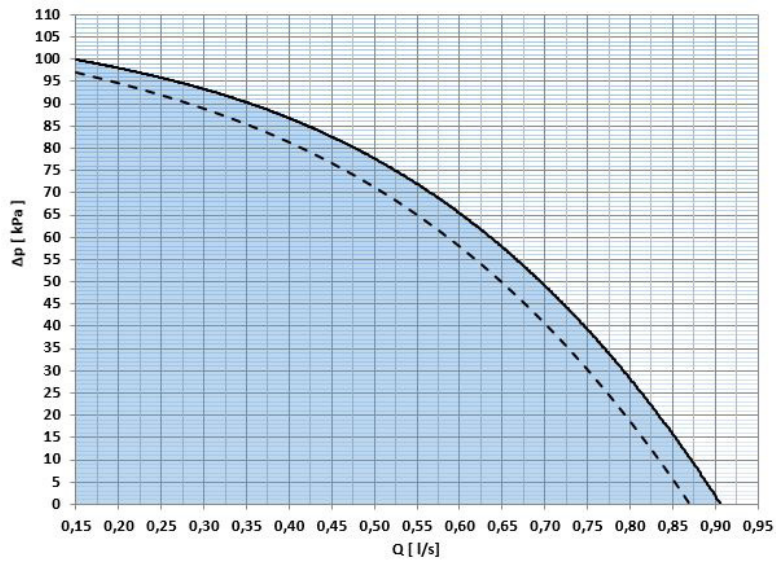

$\Delta P$  [kPa] = Available pressure  
 $Q$  [l/s] = Water flow-rate

----- Maximum head of the circulator with configuration of integration electric heater.  
 ■ Circulator operating field

## Absorption of the circulator increased at the unit 250 L B

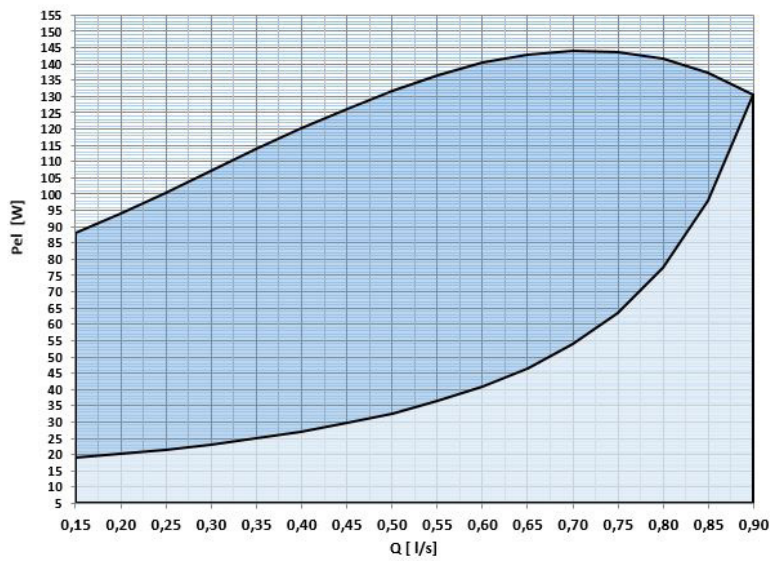

$P_{el}$  [W] = Electrical power input  
 $Q$  [l/s] = Water flow-rate

■ Circulator operating field

# General technical data

## Available pressure of the circulator GAS BOILER UC

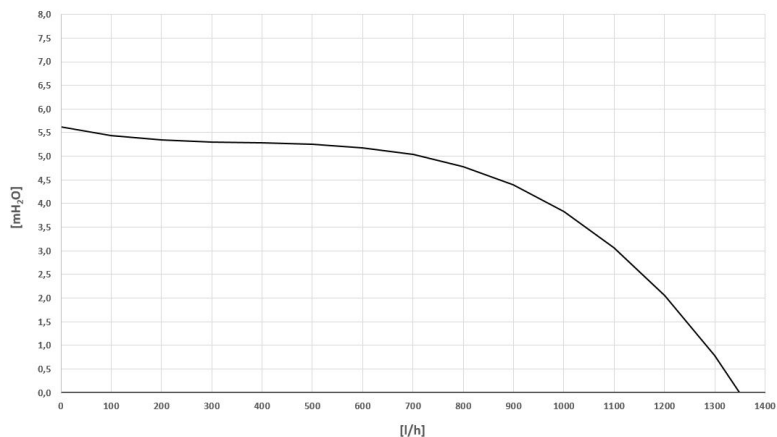

[mH<sub>2</sub>O] = Available pressure  
[l/h] = Water flow-rate

## Available pressure of the circulator GAS BOILER FE 24.4

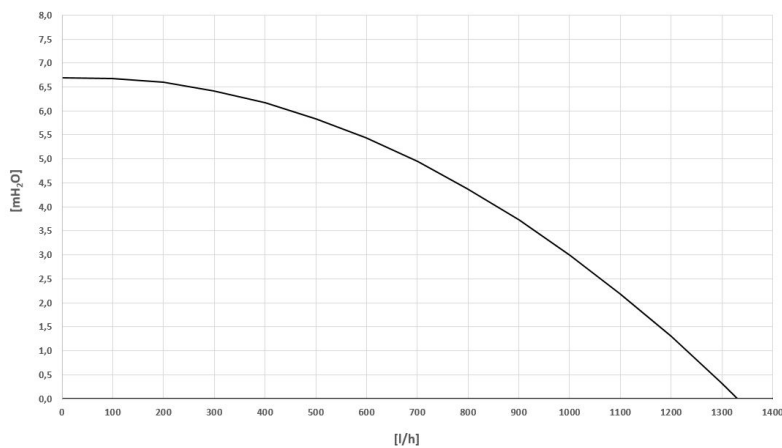

[mH<sub>2</sub>O] = Available pressure  
[l/h] = Water flow-rate

## Available pressure of the circulator GAS BOILER FE 33.4

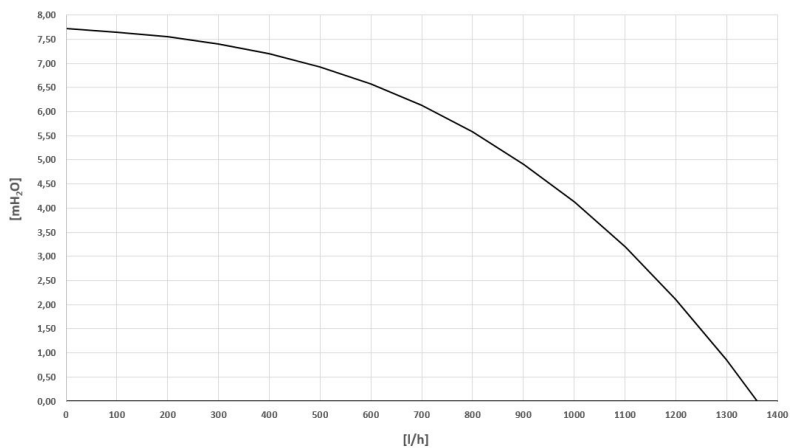

[mH<sub>2</sub>O] = Available pressure  
[l/h] = Water flow-rate

## Pressure drop for direct booster system circulator

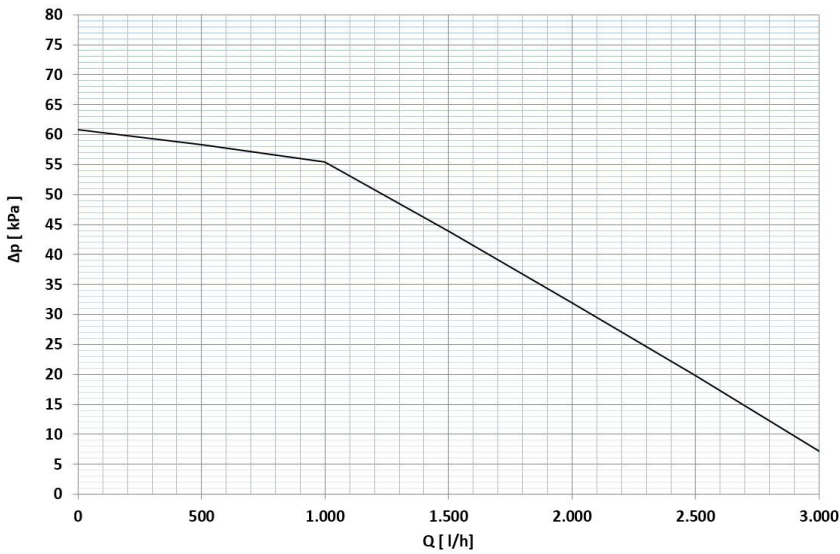

ΔP [kPa] = Available pressure  
Q [l/h] = Water flow-rate

## Available head for mixed booster system circulator

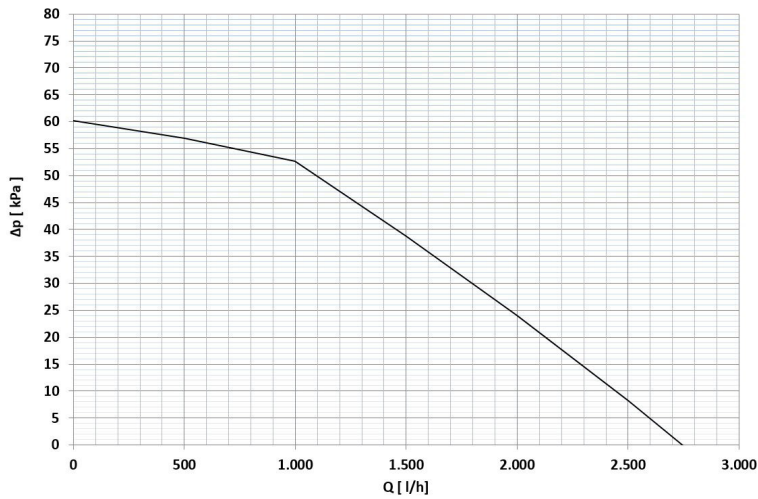

PeI [W] = Electrical power input  
Q [l/h] = Water flow-rate

## Pressure drops - VDACSX accessory

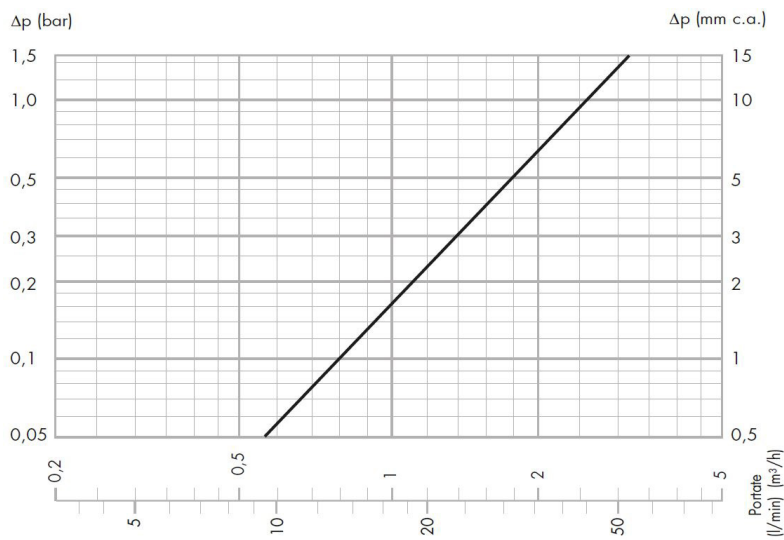

# General technical data

## KCSX secondary circuit kit available pressure

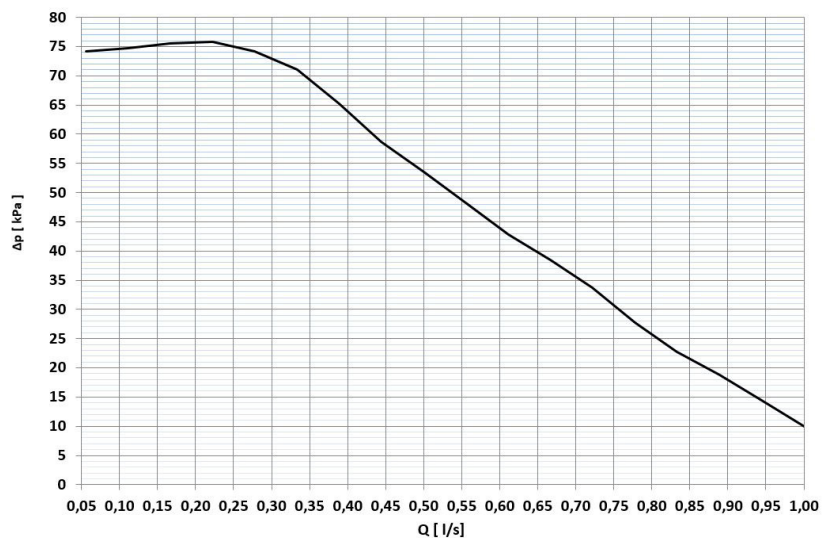

$\Delta P$  [kPa] = Available pressure  
 $Q$  [l/s] = Water flow-rate

## KCSX secondary circuit kit absorption

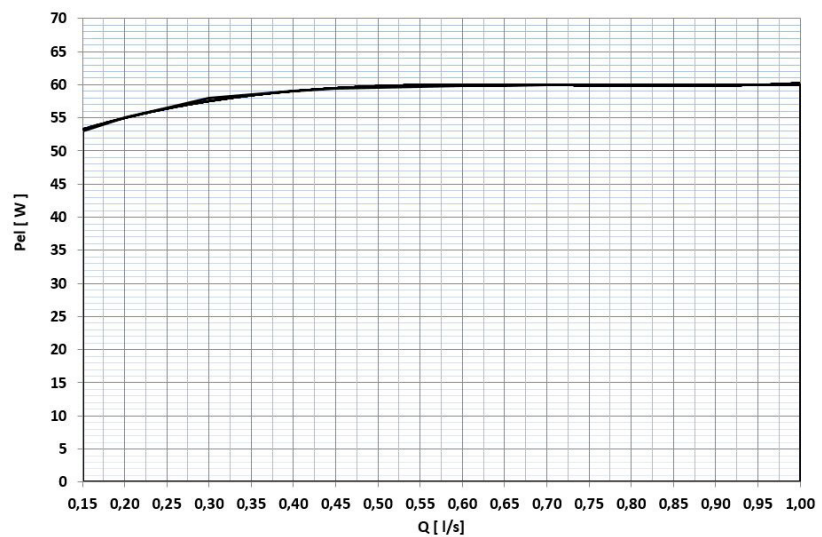

$P_{el}$  [W] = Electrical power input  
 $Q$  [l/s] = Water flow-rate

## Sizing the refrigerant pipes

Equivalent length of pipes (metres) = Effective length (metres) +  
Number of bends x K

Consider K= 0.3 m per wide radius elbow bend.

Consider K= 0.5 m per standard 90° elbow bend.

⚠ To correctly install the refrigerant pipes and charge the refrigerant gas, refer to the SPHERA EVO 2.0 MANUAL

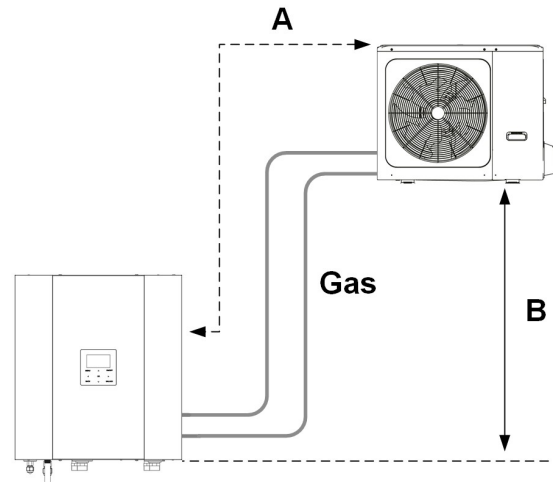

SIZE		2.1	3.1	4.1	5.1	6.1	7.1	8.1
<b>Length and height difference of refrigerant pipes</b>								
A - Refrigerant pipe min/max equivalent length	m	2 - 30	2 - 30	2 - 30	2 - 30	2 - 30	2 - 30	2 - 30
B - Maximum refrigerant pipe height difference with outdoor unit higher than indoors unit	m	25	25	25	25	25	25	25
B - Maximum refrigerant pipe height difference with outdoor unit underthan indoor unit.	m	25	25	25	25	25	25	25
<b>Diameters of refrigerant pipes</b>								
Gas pipe diameter	inch	5/8"	5/8"	5/8"	5/8"	5/8"	5/8"	5/8"
Fluid line diameter	inch	1/4"	1/4"	3/8"	3/8"	3/8"	3/8"	3/8"
Additional charge per metre	kg/m	0,020	0,020	0,038	0,038	0,038	0,038	0,038

## Determination of cooling and heating power loss

The equivalent length of the cooling lines results in a loss of cooling and heating power supplied to the circuit and DHW system. The graph shows the amount of this loss of powergh

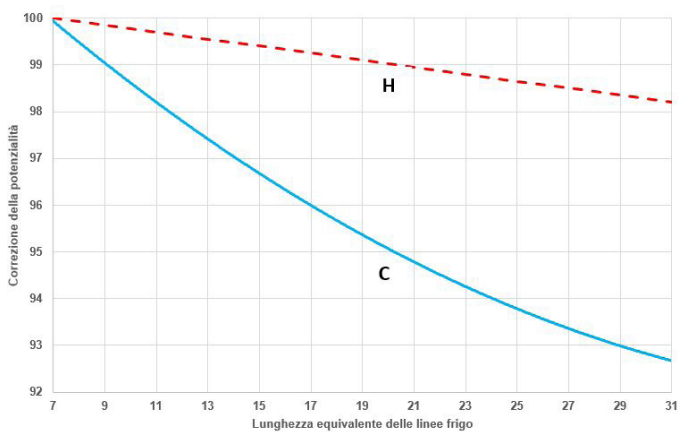

C = Cooling power efficiency curve

H = Heating power efficiency curve

# Water connections

Here are some diagrams of system connections provided as an indication. The connection and design of the system must be carried out in accordance with national regulations in force.

The diagrams do not report the mandatory components to be taken care of by the customer.

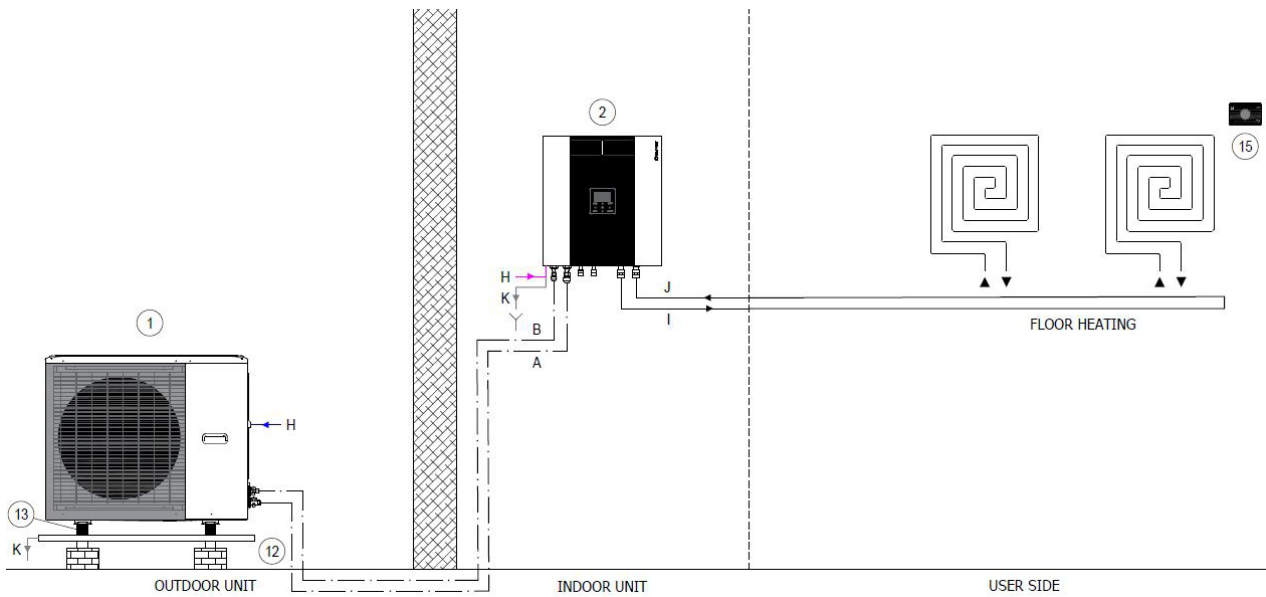

1. Outdoor unit
2. Indoor unit
3. 2 zone kit (KIRE2HX-KIRE2hXL)
4. Single zone kit (KCSX)
5. Integration electric heater (EH024 - EH3 - EH6 - EH9)
6. Drain-back solar integration for domestic hot water (SOLX) --> only Tower
7. Solar panel
8. Hybrid solution (HYSO24 - HYSO34)
9. 40L inertial storage tank (ACI40X)
10. 1-litre circuit breaker (DIX)
11. 50-litre circuit breaker- 60L inertial storage tank (DI50X - ACI60X)
12. Condensate drain pan (DTX)
13. Anti-vibration mount (APAVX - ASTFX)
14. Brackets wall (KSIPX)
15. Chronothermostat (HID-TCXB - HID-TCXN)
16. DHW storage (ACS200X- ACS300X - ACS500X + SCS08X - SCS12X)
17. ElfoControl<sup>3</sup> EVO

- A. Liquid line
- B. Gas line
- C. DHW outlet
- D. DHW recirculation inlet
- E. Aqueduct inlet
- F. Solar outlet
- G. Solar inlet
- H. Power input
- I. System return
- J. System supply
- K. Condensate drain

220-240V~50Hz  
380-415V 3N ~50HZ con EH3 - EH6 - EH9

2.1 - 5.1 single phase 220-240V ~50Hz  
6.1 - 8.1 single phase 220-240V ~50Hz  
6.1 - 8.1 three-phase 380415V 3N~50Hz

..... BUS RS 485  
 \_\_\_\_\_ Technical water  
 \_\_\_\_\_ Domestic cold water  
 \_\_\_\_\_ Domestic hot water  
 \_\_\_\_\_ Condensate drain

# Electrical connections

The electrical hookup must be conforming with the local regulations. The hookup must be done by a specialised technician, qualified to work on live equipment.

SPHERA EVO 2.0 can be controlled with the on-board controller. To operate the unit, you may use: the ELFOControl<sup>3</sup> EVO supervision system or normal electromechanical thermostats.

For more information on connections, consult the installation manual.

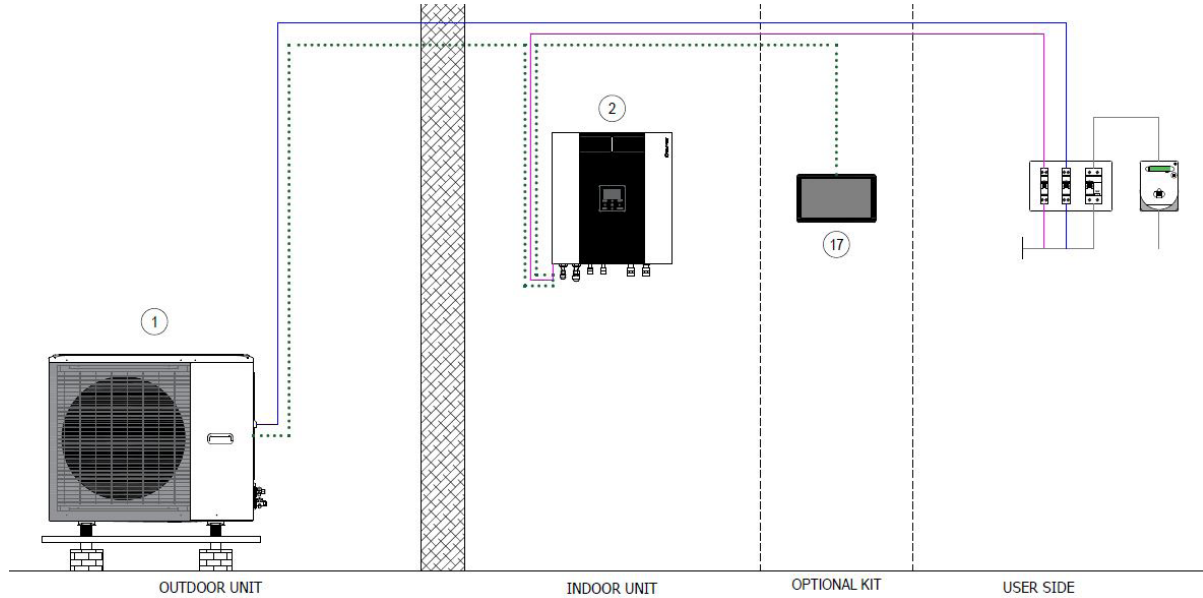

1. Outdoor unit
2. Indoor unit
3. 2 zone kit (KIRE2HX-KIRE2hXL)
4. Single zone kit (KCSX)
5. Integration electric heater (EH024 - EH3 - EH6 - EH9)
6. Integrazione solare per sanitario (SOLX) --> solo nel tower
7. Solar panel
8. Hybrid solution (HYSO24 - HYSO34)
9. 40L inertial storage tank (ACI40X)
10. 1-litre circuit breaker (DIX)
11. 50-litre circuit breaker- 60L inertial storage tank (DI50X - ACI60X)
12. Condensate drain pan (DTX)
13. Anti-vibration mount (APAVX - ASTFX)
14. Brackets wall (KSIPX)
15. Chronothermostat (HID-TCXB - HID-TCXN)
16. DHW storage (ACS200X- ACS300X - ACS500X + SCS08X - SCS12X)
17. ElfoControl<sup>3</sup> EVO

- A. Liquid line
- B. Gas line
- C. DHW outlet
- D. Ingresso ricircolo ACS
- E. Aqueduct inlet
- F. Solar outlet
- G. Solar inlet
- H. Power input
- I. System return
- J. System supply
- K. Condensate drain

— 220-240V~50Hz  
380-415V 3N ~50HZ con EH3 - EH6 - EH9

— 2.1 - 5.1 single phase 220-240V ~50Hz  
6.1 - 8.1 single phase 220-240V ~50Hz  
6.1 - 8.1 three-phase 380415V 3N~50Hz

... BUS RS 485  
— Technical water  
— Domestic cold water  
— Domestic hot water  
— Condensate drain



# Auxiliary and hybrid version heat sources

The electrical connection must be carried out in accordance with national regulations in force. The connection must be carried out by specialised personnel who are qualified to work with live voltage. SPHERA EVO 2.0 can be controlled with the built-in control panel. The unit can be called using: the ELFOControl3 EVO supervisory system or common electromechanical thermostats. Refer to the installation manual for more information on the connections.

⚠ Only one of IBH or AHS can be managed

The additional electric heater or boiler can operate as::

- Integration: when it is not convenient/possible to work with the heat pump capacity alone
- Replacement: outside the work settings of the heat pump
- Back-up: in case of unit failure (the unit keeps the pump running at maximum speed)

A third-party supplier's boiler, if any, must be installed in parallel with the heat pump and can act:

- on the system and DHW: installed directly on the system, in this case its operation will require a dedicated T1 temperature probe (to be selected separately) to be installed downstream

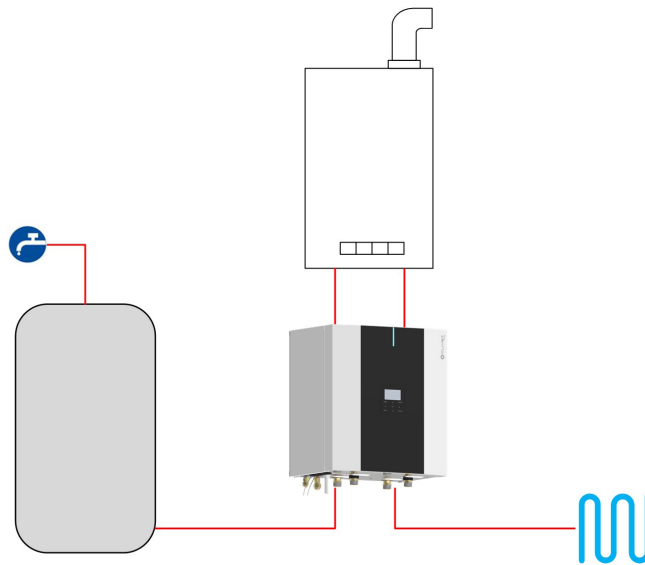

⚠ Requires installation of the KCCEX kit, the T1 probe is included and must be fitted inside the indoor unit downstream of the boiler

- only on the system: installed on a hydraulic separator, where the T1 probe (to be selected separately) must also be fitted

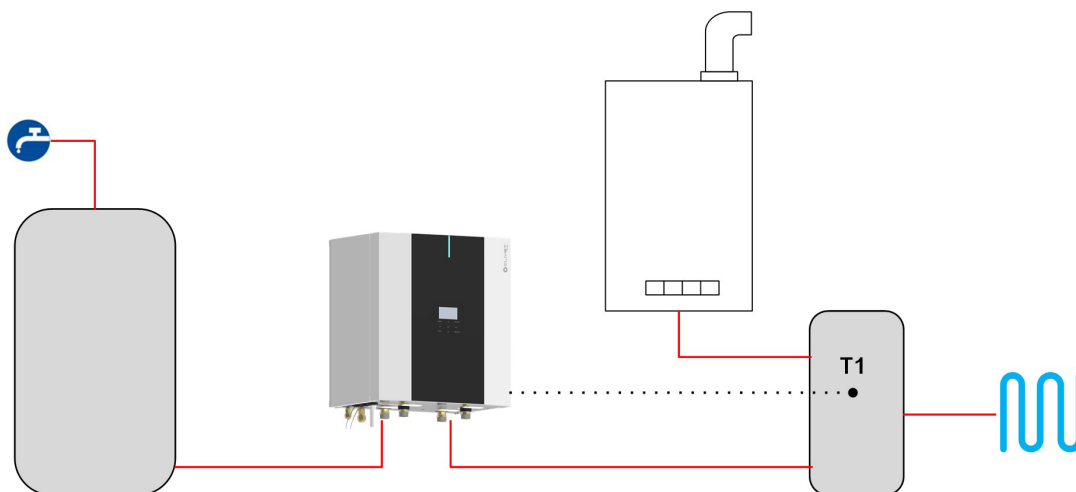

# Auxiliary and hybrid version heat sources

The activation operating mode (in Heating, DHW production or both) must be selected with the dip-switches on the board during installation.

Activation of the auxiliary source is linked to the simultaneous presence of 3 conditions, each of which is associated with a parameter that can be adjusted during initial start-up on the user interface:

- very low outdoor temperature  
parameter  $T4\_IBH\_ON$  or  $T4\_AHS\_ON$  (default  $-5^{\circ}\text{C}$ , adjustable  $-15\div 30$ ): the minimum outdoor air temperature for heat pump operation only

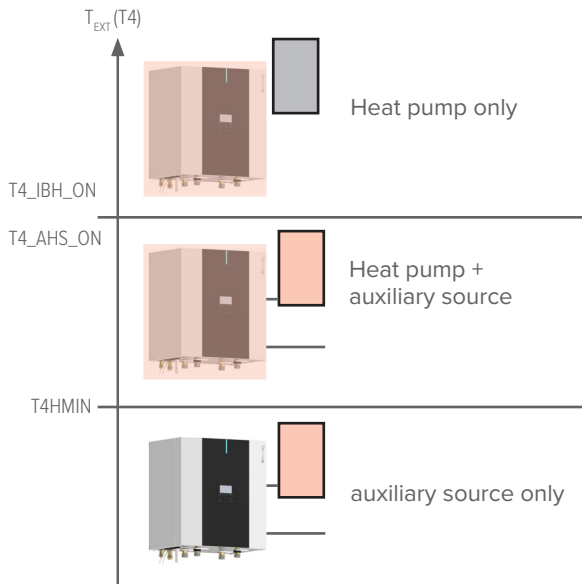

- ⚠ To make the auxiliary source work only as a replacement for the unit, set the parameter to the same value as  $T4HMIN$  (default  $-15^{\circ}\text{C}$ , adjustable  $-25\div 15$ ): the minimum outdoor air temperature at which the heat pump can operate.

- supply temperature too far from the set-point  
parameter  $dt1\_IBH\_ON$  or  $dt1\_AHS\_ON$  (default  $5^{\circ}\text{C}$ , adjustable  $2\div 10$ ): the minimum  $\Delta T$  between the water set-point  $TS1$  and unit supply set-point  $T1$
- too long to reach the set-point  
parameter  $t\_IBH\_DELAY$  or  $t\_AHS\_DELAY$  (default 30min, adjustable  $5\div 120$ ): the maximum waiting time between compressor start-up and auxiliary source activation

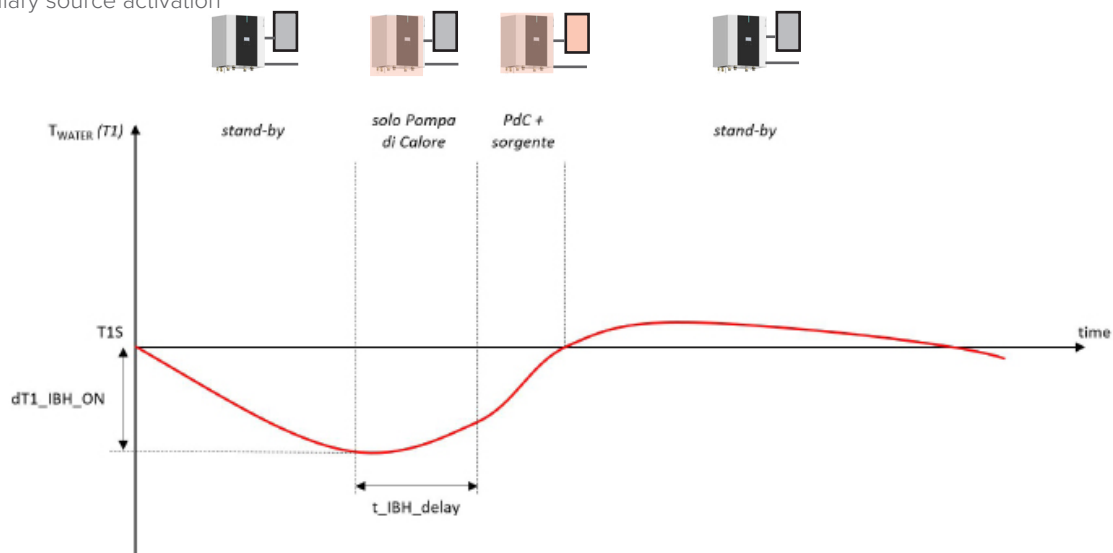

- ⚠ The BACKUP HEATER function on the HMI allows activation of the IBH or AHS auxiliary source to be forced

The unit can manage the AHS set-point dynamically with a 0-10V signal, with parameters:

- $MAX\_SETHEATER$  (default:  $80^{\circ}\text{C}$ , adjustable) and  $MIN\_SETHEATER$  (default:  $30^{\circ}\text{C}$ , adjustable): the minimum and maximum set-points that can be set in the boiler
- $MAX\_SIGHEATER$  (default: 10V, adjustable) and  $MIN\_SIGHEATER$  (default: 3V, adjustable): the 0-10V signals linked to the minimum and maximum set-points that can be set in the boiler

# Auxiliary and hybrid version heat sources

## Hybrid versions with UC version boiler

The hybrid heat pumps are equipped with a 4-pipe boiler for DHW production and Heating.

The UC GAS BOILER is made as follows

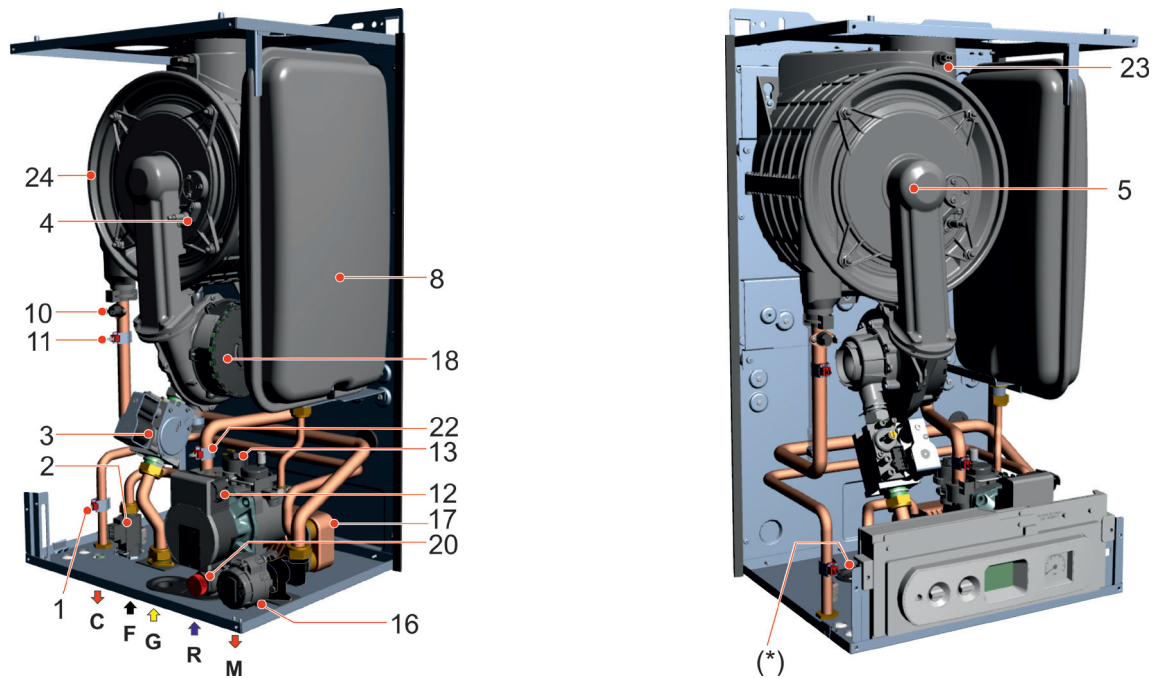

#	NAME	DESCRIPTION
1	SS	DHW water temperature sensor
2	FLS	Flow switch with cold water filter
3	VG	Gas valve
4	E.ACC/RIL	Switch-on Electrode/ detection
5	-	Burner
8	-	Expansion tank
10	TL	Safety thermostat
11	SR	Water temperature sensor - Heating supply
12	P	Circulator
13	DK	Low water control pressure switch
16	-	Switching valve
17	-	DHW plate exchanger
18	VM	Fan
20	-	Pressure relief valve
22	SRR	Water temperature sensor - return
23	TLC	Smoke manifold safety thermostat
24	-	Steel exchanger/condenser
(*)	-	Condensate drain trap outlet position
C	-	DHW output (G 1/2")
G	-	Gas inlet (G 3/4")
F	-	Water inlet for DHW (G 1/2")
M	-	System supply (G 3/4")
R	-	System return (G 3/4")

# Auxiliary and hybrid version heat sources

## Versioni ibride con caldaia in versione FE

FE GAS BOILER is a boiler designed to operate on Natural Gas (G20), Liquid Gas (G30-G31), Propane Air (G230) and it can also regulate itself to operate with natural gas and hydrogen mixtures (80%/20%).

The FE GAS BOILER is made as follows:

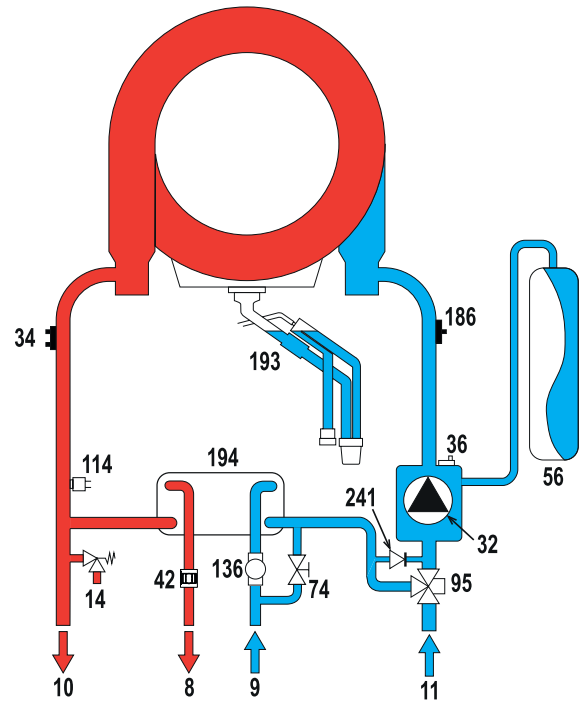
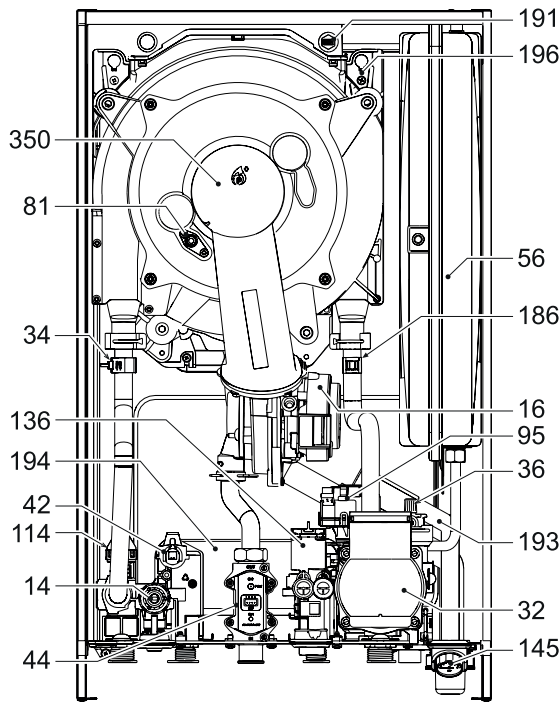

#	DESCRIPTION
8	DHW outlet (G 1/2")
9	DHW water inlet (G 1/2")
10	System supply (G 3/4")
11	System return (G 3/4")
14	Pressure relief valve
16	Fan
32	Circulator
34	Water temperature sensor - Heating supply
36	Automatic air vent
42	DHW water temperature sensor
44	Gas valve
56	Expansion tank
74	System filling shut-off valve
81	Switch-on Electrode/ detection
95	Switching valve
114	Water pressure switch
136	Flowmeter
145	Hydrometer
186	Water temperature sensor - return
191	Smoke temperature sensor
193	Sifone
194	Plate heat exchanger for DHW
196	Drain pan
241	Automatic bypass (inside the pump group)
350	Burner group/fan

# System connections

## General description of the system and possible connections

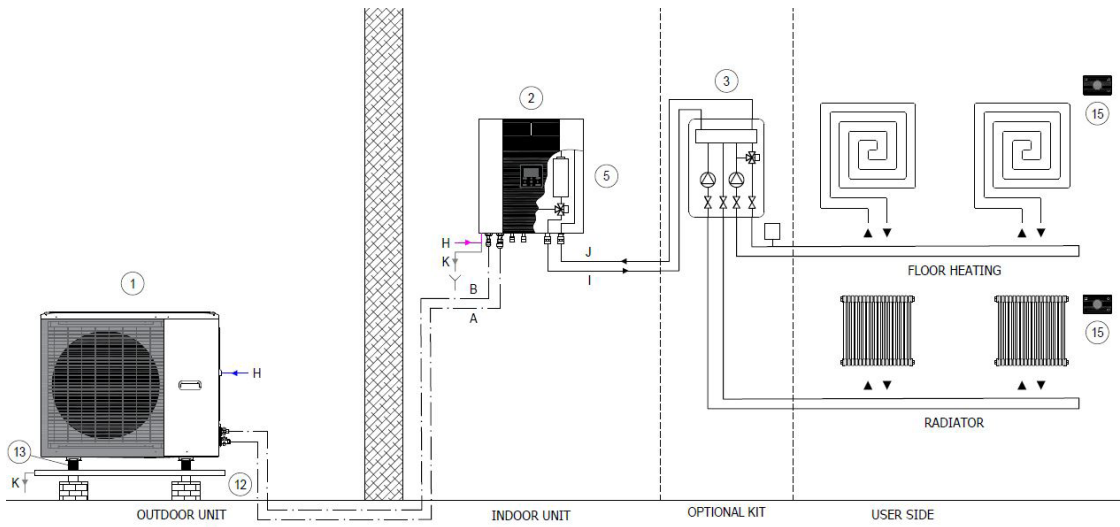

**Additional electric heater**

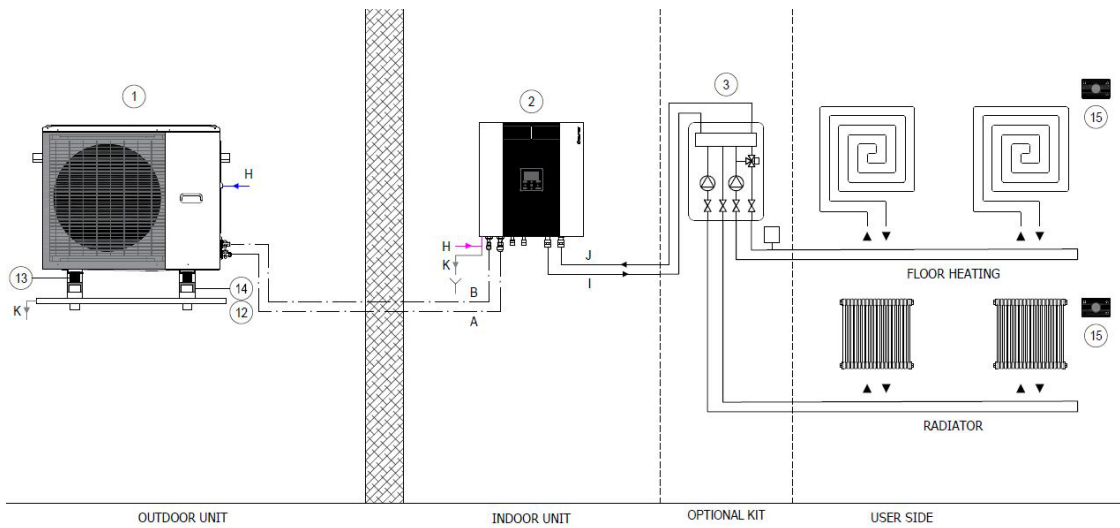

**2 zone kit**

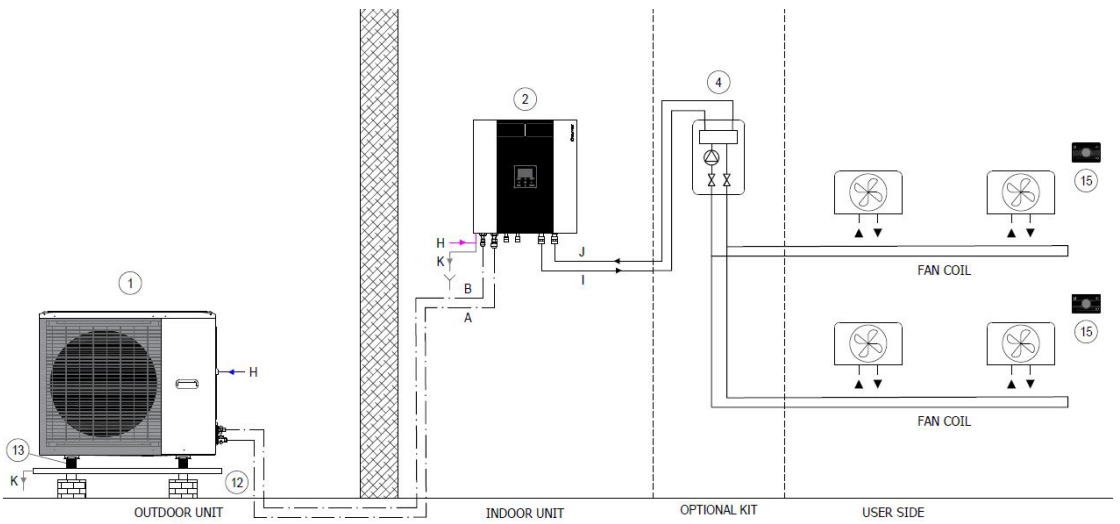

**Single zone kit**

## General description of the system and possible connections

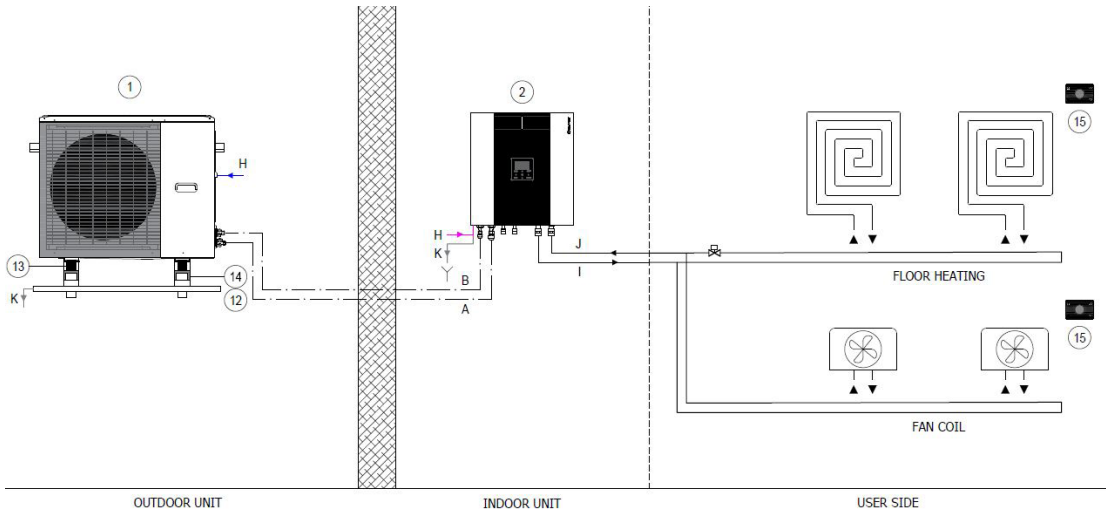

### Single Zone

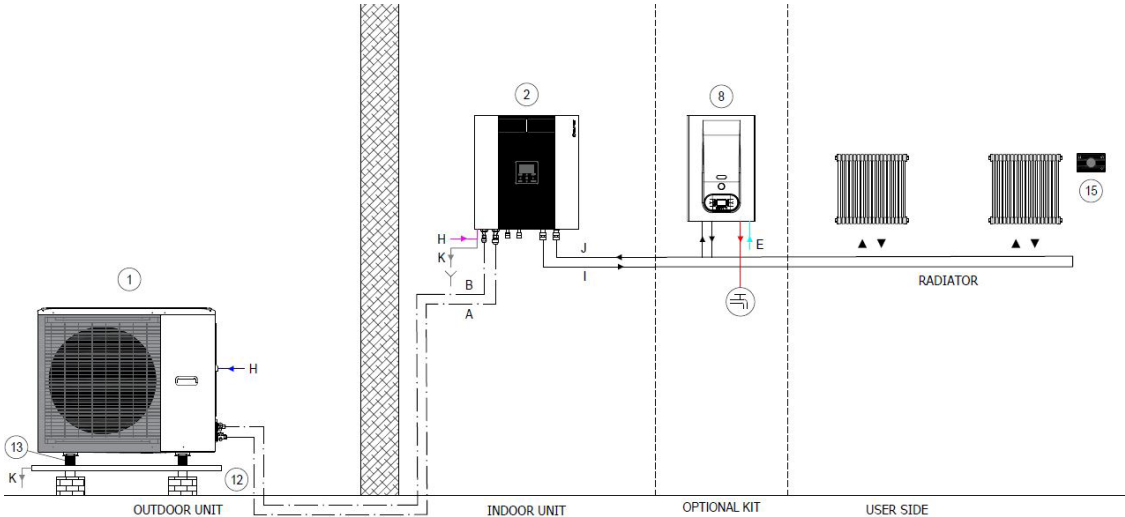

### Hybrid solution

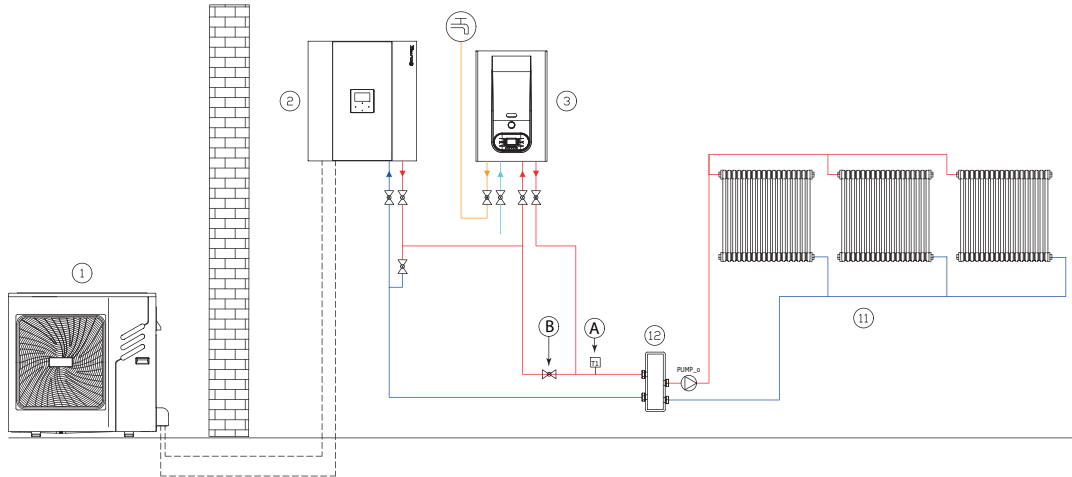

### Hybrid solution "Factory made"

# System connections

## General description of the system and possible connections

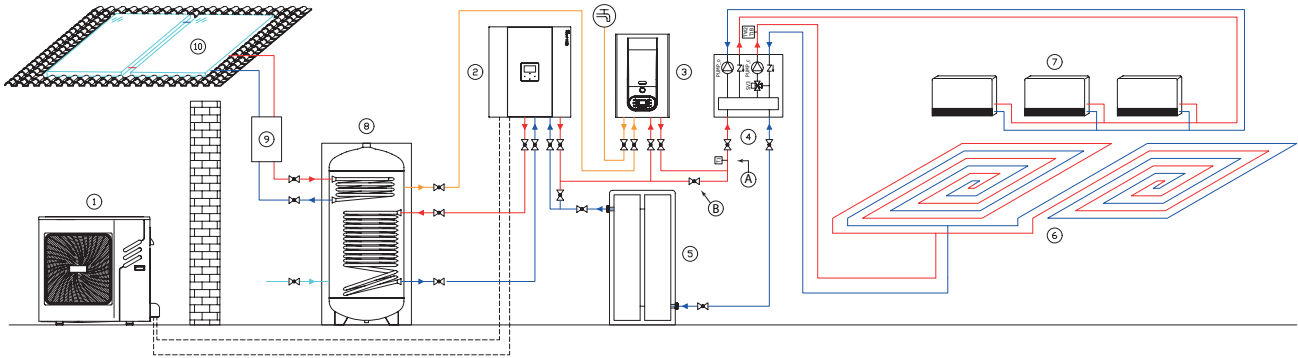

### Hybrid solution "Factory made" with DHW storage tank ACS

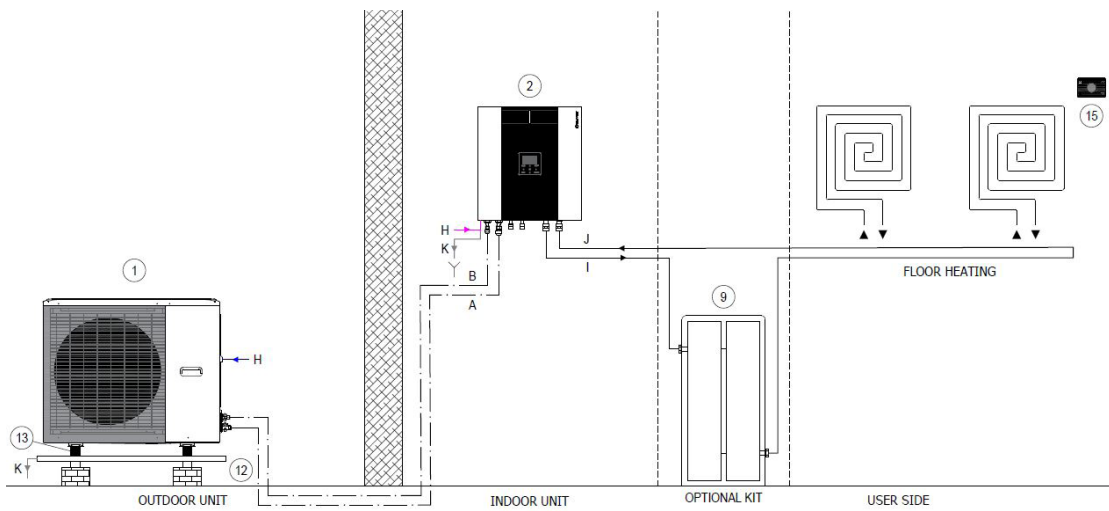

### Inertial storage 40 L

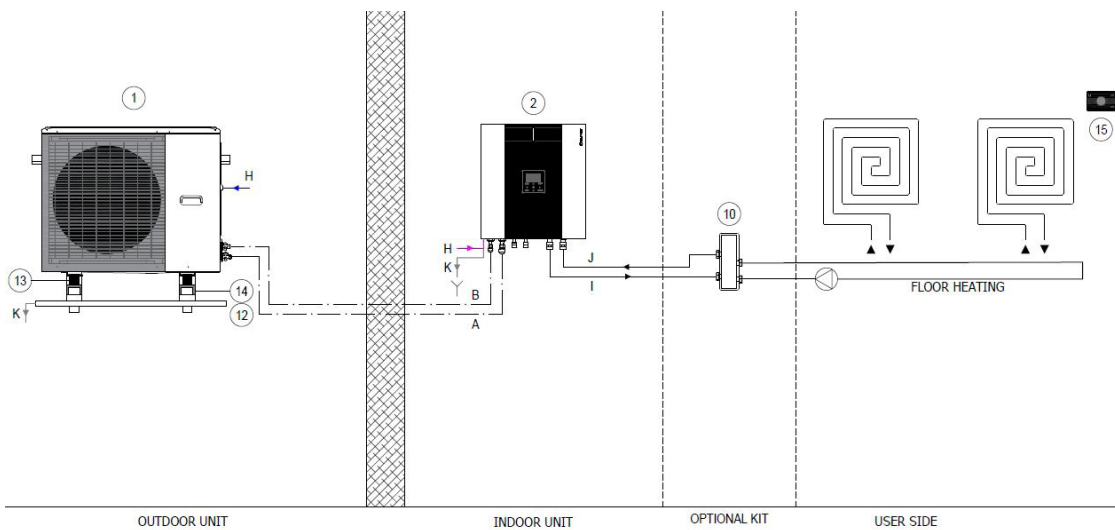

1 L circuit breaker

## General description of the system and possible connections

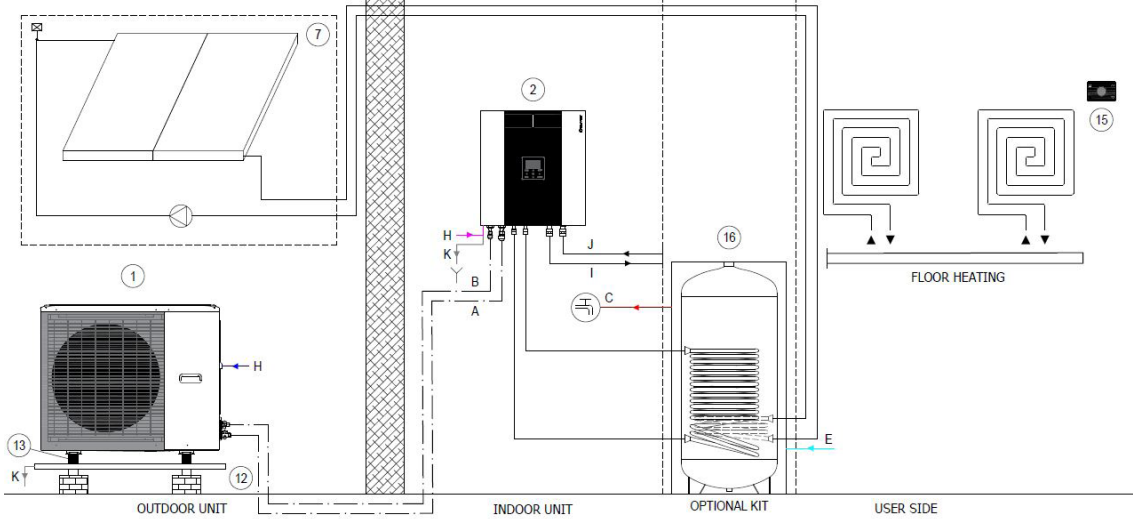

### DHW storage

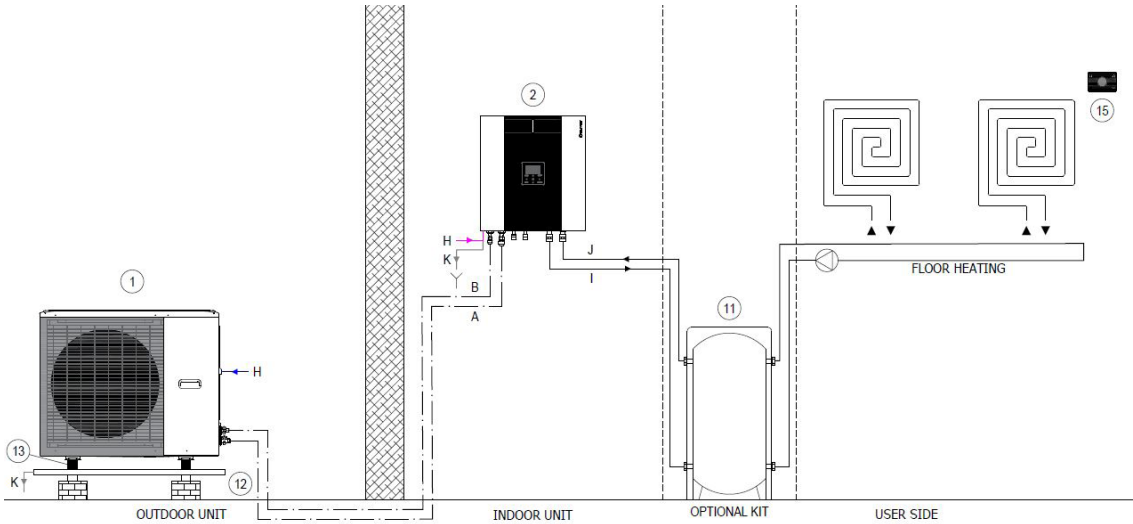

circuit breaker 50L - inertial storage 60L



# Data for the UNI/TS 11300 calculation

Clivet S.p.A. declares that the data to be used for the calculation pursuant to UNI/TS 11300 part 4 of the efficiency of their heat pump are given in the following tables.

The data given in this document may be updated without advance notice by the manufacturer when upgrading his product range.

## UNI/TS 11300 Part 4

### SPHERA EVO 2.0 - Size 2.1

Data for determination of COPPL T delivery 20°C		Tdesignh	A	B	C	D
2.1	Te	-10	-7	2	7	12
	PLR	100%	88%	54%	35%	15%
	DC		4,74	4,50	4,32	4,33
	CR		1,00	0,65	0,44	0,19
	P	5,39	4,74	3,05	1,99	1,45
	COP (part load)		3,15	4,96	6,81	6,23
	COP (full load)		3,15	4,46	5,42	6,37
	Fcop		1,00	1,11	1,26	0,98
Data to be provided for power and COP under full load cold source air						
2.1	Te	Tm	-7	2	7	12
	Heating capacity $\Phi_{H,HP out}$ (kW)	35°C	4,74	4,50	4,32	4,33
		45°C	4,31	4,35	4,16	4,16
		55°C	4,40	4,40	4,08	4,50
	COP	35°C	3,15	4,46	5,42	6,37
		45°C	2,51	3,27	3,93	4,52
55°C	1,99	2,56	3,00	3,44		
DHW Power and COP data under full load			Te			
2.1	Te	Tm	7	15	20	35
	Heating capacity $\Phi_{H,HP out}$ (kW)	55°C	4,08	5,11	5,71	6,85
	COP	55°C	3,00	3,84	4,23	3,90

### SPHERA EVO 2.0 - Size 3.1

Data for determination of COPPL T delivery 20°C		Tdesignh	A	B	C	D
3.1	Te	-10	-7	2	7	12
	PLR	100%	88%	54%	35%	15%
	DC		5,51	5,89	6,18	6,28
	CR		1,00	0,57	0,35	0,15
	P	6,26	5,51	3,30	2,24	1,45
	COP (part load)		3,13	4,91	7,11	5,70
	COP (full load)		3,13	4,15	5,21	6,10
	Fcop		1,00	1,18	1,36	0,93
Data to be provided for power and COP under full load cold source air						
3.1	Te	Tm	-7	2	7	12
	Heating capacity $\Phi_{H,HP out}$ (kW)	35°C	5,51	5,89	6,18	6,28
		45°C	5,22	6,42	6,03	6,53
		55°C	5,15	5,46	5,94	6,64
	COP	35°C	3,13	4,15	5,21	6,10
		45°C	2,41	3,07	3,83	4,41
55°C	2,03	2,56	3,07	3,55		
DHW Power and COP data under full load			Te			
3.1	Te	Tm	7	15	20	35
	Heating capacity $\Phi_{H,HP out}$ (kW)	55°C	5,94	6,99	7,33	8,80
	COP	55°C	3,07	3,97	4,44	4,10

# Data for the UNI/TS 11300 calculation

## SPHERA EVO 2.0 - Size 4.1

Data for determination of COPPL T delivery 20°C		Tdesignh	A	B	C	D
4.1	Te	-10	-7	2	7	12
	PLR	100%	88%	54%	35%	15%
	DC		7,15	5,64	8,30	8,21
	CR		1,00	0,78	0,34	0,15
	P	8,13	7,15	4,65	2,91	1,85
	COP (part load)		3,30	5,17	7,08	6,01
	COP (full load)		3,30	3,69	5,31	6,41
	Fcop		1,00	1,40	1,33	0,94
Data to be provided for power and COP under full load cold source air		Te				
4.1	Te	Tm	-7	2	7	12
	Heating capacity $\Phi_{H,HP out}$ (kW)	35°C	7,15	5,64	8,30	8,21
		45°C	6,34	6,59	8,22	8,07
		55°C	6,08	6,27	7,50	7,55
	COP	35°C	3,30	3,69	5,31	6,41
		45°C	2,56	3,26	3,95	4,69
55°C		2,17	2,69	3,19	3,72	
DHW Power and COP data under full load		Te				
4.1	Te	Tm	7	15	20	35
	Heating capacity $\Phi_{H,HP out}$ (kW)	55°C	7,50	8,37	9,18	11,02
	COP	55°C	3,19	4,11	4,50	4,15

## SPHERA EVO 2.0 - Size 5.1

Data for determination of COPPL T delivery 20°C		Tdesignh	A	B	C	D
5.1	Te	-10	-7	2	7	12
	PLR	100%	88%	54%	35%	15%
	DC		8,45	9,30	10,09	10,26
	CR		1,00	0,56	0,33	0,14
	P	9,60	8,45	5,23	3,47	1,96
	COP (part load)		3,18	5,03	7,33	6,16
	COP (full load)		3,18	4,12	5,01	5,97
	Fcop		1,00	1,22	1,46	1,03
Data to be provided for power and COP under full load cold source air		Te				
5.1	Te	Tm	-7	2	7	12
	Heating capacity $\Phi_{H,HP out}$ (kW)	35°C	8,45	9,30	10,09	10,26
		45°C	7,71	9,16	10,01	10,06
		55°C	7,08	8,49	9,60	9,19
	COP	35°C	3,18	4,12	5,01	5,97
		45°C	2,59	3,11	3,86	4,32
55°C		2,11	2,66	3,10	3,65	
DHW Power and COP data under full load		Te				
5.1	Te	Tm	7	15	20	35
	Heating capacity $\Phi_{H,HP out}$ (kW)	55°C	9,60	8,99	8,78	10,54
	COP	55°C	3,10	4,03	4,53	4,18

Terms and definitions

Tm = Delivery temperature

Tdesignh = A - Average design climate temperature (pursuant to UNI EN 14825)

A, B, C, D = names of the four conditions with which different outdoors air temperatures are associated (Te)

Te = Outdoors air temperature

PLR = part load ratio

DC = power under full load referred to the specified temperatures

CR = heat pump load factor

P = system power demand

COP' (full load) = COP under full load referred to the indicated outdoors air temperatures

COP' (partial load) = COP under partial load referred to the indicated outdoors air temperatures

fCOP = COP correction factor, as follows: COP' (full load) / COP (partial load)

HP = heat pump

DHW = domestic hot water

# Data for the UNI/TS 11300 calculation

## SPHERA EVO 2.0 - Size 6.1

Data for determination of COPPL T delivery 20°C		Tdesignh	A	B	C	D
6.1	Te	-10	-7	2	7	12
	PLR	100%	88%	54%	35%	15%
	DC		10,69	13,01	12,13	12,26
	CR		1,00	0,50	0,35	0,15
	P	12,14	10,69	6,57	4,48	3,67
	COP (part load)		3,07	4,68	6,90	6,33
	COP (full load)		3,07	3,93	5,00	5,68
	Fcop		1,00	1,19	1,38	1,12
Data to be provided for power and COP under full load cold source air		Te				
6.1	Te	Tm	-7	2	7	12
	Heating capacity $\Phi_{H,HP out}$ (kW)	35°C	10,69	13,01	12,13	12,26
		45°C	11,21	12,52	12,30	11,56
		55°C	10,10	12,05	12,07	10,89
	COP	35°C	3,07	3,93	5,00	5,68
		45°C	3,14	3,34	3,80	4,59
55°C		1,76	2,88	3,10	3,78	
DHW Power and COP data under full load		Te				
6.1	Te	Tm	7	15	20	35
	Heating capacity $\Phi_{H,HP out}$ (kW)	55°C	12,07	12,30	13,71	16,45
	COP	55°C	3,10	4,19	4,59	4,23

## SPHERA EVO 2.0 - Size 7.1

Data for determination of COPPL T delivery 20°C		Tdesignh	A	B	C	D
7.1	Te	-10	-7	2	7	12
	PLR	100%	88%	54%	35%	15%
	DC		12,33	12,71	14,51	12,31
	CR		1,00	0,60	0,34	0,17
	P	14,01	12,33	7,97	5,21	3,67
	COP (part load)		2,87	4,62	7,07	6,70
	COP (full load)		2,87	4,00	4,70	5,70
	Fcop		1,00	1,16	1,50	1,18
Data to be provided for power and COP under full load cold source air		Te				
7.1	Te	Tm	-7	2	7	12
	Heating capacity $\Phi_{H,HP out}$ (kW)	35°C	12,33	12,71	14,51	12,31
		45°C	11,27	11,21	14,00	11,61
		55°C	10,35	11,71	13,85	10,94
	COP	35°C	2,87	4,00	4,70	5,70
		45°C	2,61	3,11	3,65	4,61
55°C		2,18	2,91	3,05	3,80	
DHW Power and COP data under full load		Te				
7.1	Te	Tm	7	15	20	35
	Heating capacity $\Phi_{H,HP out}$ (kW)	55°C	13,85	12,35	13,76	16,51
	COP	55°C	3,05	4,21	4,60	4,25

Terms and definitions

Tm = Delivery temperature

Tdesignh = A - Average design climate temperature (pursuant to UNI EN 14825)

A, B, C, D = names of the four conditions with which different outdoors air temperatures are associated (Te)

Te = Outdoors air temperature

PLR = part load ratio

DC = power under full load referred to the specified temperatures

CR = heat pump load factor

P = system power demand

COP' (full load) = COP under full load referred to the indicated outdoors air temperatures

COP' (partial load) = COP under partial load referred to the indicated outdoors air temperatures

fCOP = COP correction factor, as follows: COP' (full load) / COP (partial load)HP= heat pump

DHW = domestic hot water

# Data for the UNI/TS 11300 calculation

## SPHERA EVO 2.0 - Size 8.1

Data for determination of COPPL T delivery 20°C		Tdesignh	A	B	C	D
8.1	Te	-10	-7	2	7	12
	PLR	100%	88%	54%	35%	15%
	DC		13,82	14,30	16,01	15,20
	CR		1,00	0,59	0,34	0,16
	P	15,71	13,82	8,55	5,88	3,67
	COP (part load)		2,86	4,59	7,13	6,44
	COP (full load)		2,86	3,85	4,55	5,43
	Fcop		1,00	1,19	1,57	1,19
Data to be provided for power and COP under full load cold source air		Te				
8.1	Te	Tm	-7	2	7	12
	Heating capacity $\Phi_{H,HP out}$ (kW)	35°C	13,82	14,30	16,01	15,20
		45°C	12,35	13,79	16,01	14,55
		55°C	11,23	13,32	16,00	13,91
	COP	35°C	2,86	3,85	4,55	5,43
		45°C	2,58	3,28	3,60	4,49
		55°C	2,13	2,80	2,90	4,00
	DHW Power and COP data under full load		Te			
8.1	Te	Tm	7	15	20	35
	Heating capacity $\Phi_{H,HP out}$ (kW)	55°C	16,00	13,91	13,90	16,68
	COP	55°C	2,90	4,39	4,86	4,49

### Terms and definitions

Tm = Delivery temperature

Tdesignh = A - Average design climate temperature (pursuant to UNI EN 14825)

A, B, C, D = names of the four conditions with which different outdoors air temperatures are associated (Te)

Te = Outdoors air temperature

PLR = part load ratio

DC = power under full load referred to the specified temperatures

CR = heat pump load factor

P = system power demand

COP' (full load) = COP under full load referred to the indicated outdoors air temperatures

COP' (partial load) = COP under partial load referred to the indicated outdoors air temperatures

fCOP = COP correction factor, as follows: COP' (full load) / COP' (partial load)HP= heat pump

DHW = domestic hot water

# Data for the UNI/TS 11300 calculation

The specified data refer to the nominal power values under the declared conditions

## UNI/TS 11300 Part 3

SIZE	Test	Cooling capacity kW				EER			
		1	2	3	4	1	2	3	4
		100%	75%	50%	25%	100%	75%	50%	25%
<b>220-240V N 50Hz</b>									
	<b>2.1</b>	4,26	3,20	2,05	0,90	3,50	4,71	5,84	5,81
	<b>3.1</b>	6,25	4,59	2,96	1,35	3,09	4,43	6,17	7,40
	<b>4.1</b>	7,46	5,20	3,51	1,63	3,33	4,48	6,67	9,30
	<b>5.1</b>	9,10	6,43	4,25	1,94	3,09	4,26	6,73	10,48
	<b>6.1</b>	11,80	8,89	6,01	2,91	2,75	3,89	5,73	7,88
	<b>7.1</b>	12,86	9,40	6,29	2,91	2,55	3,78	5,71	7,88
	<b>8.1</b>	14,20	10,53	7,12	2,91	2,45	3,54	5,38	7,88

Reference conditions prescribed by UNI/TS 11300-3:

1. External air temperature B.S. 35°C Refrigerated water temperature at the fancoil inlet/outlet 12/7 °C
2. External air temperature B.S. 30°C Refrigerated water temperature at the fancoil outlet /7 °C
3. External air temperature B.S. 25°C Refrigerated water temperature at the fancoil outlet /7 °C
4. External air temperature B.S. 20°C Refrigerated water temperature at the fancoil outlet /7 °C

Compared to traditional systems, SPHERA EVO 2.0 provides numerous advantages from an economic point of view and in terms of energy. Below is a real case in a domestic system before and after replacing a gas boiler with a SPHERA EVO 2.0 solution.

## Natural gas

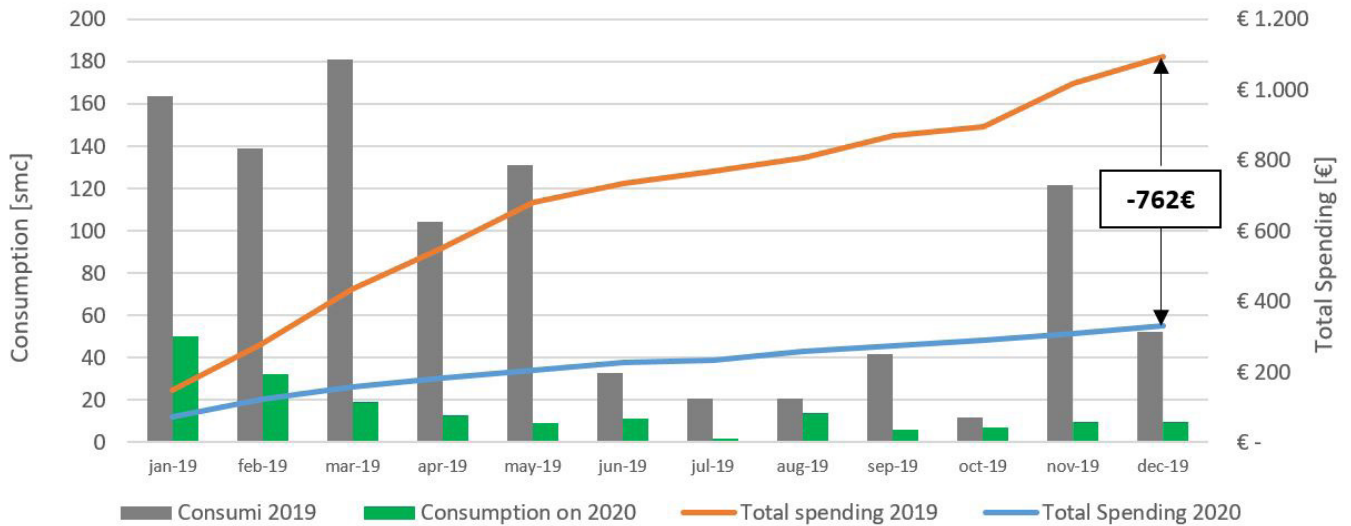

## Electricity

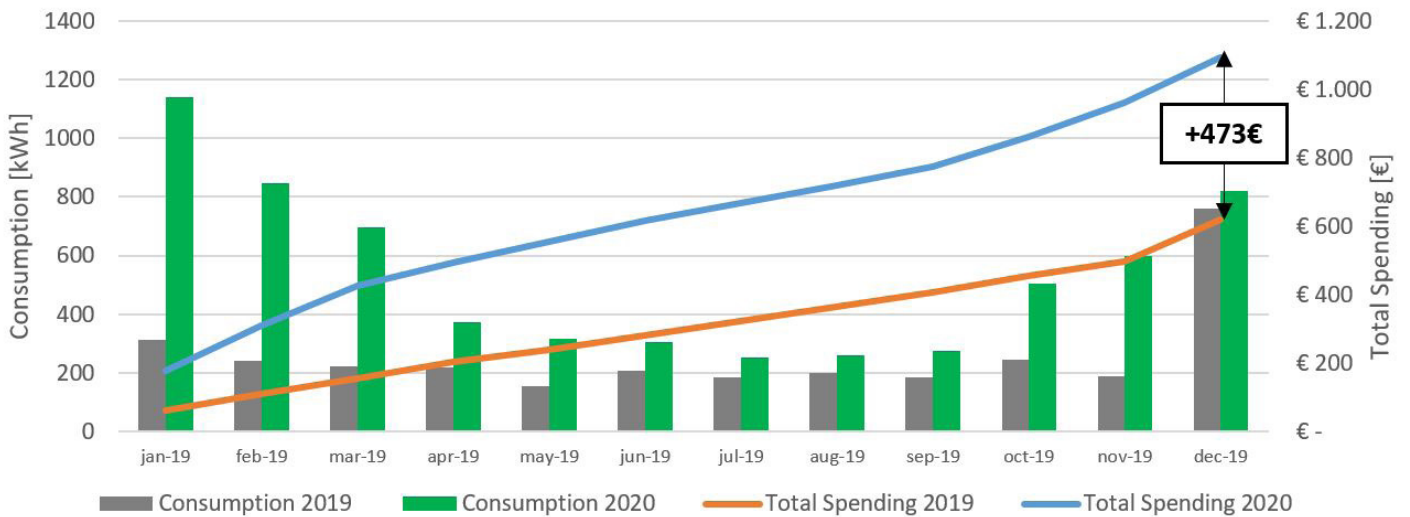

The graphs show the consumption and cost of natural gas and electricity for 2019 and 2020 (heat pump installed at the end of December 2019).

Year	Natural gas cost	Electricity cost	Total cost	Savings
2019	1092 €	620 €	1712 €	
2020	330 €	1093 €	1423 €	<b>289 € -20%</b>

The savings were obtained without changing any aspect of the previous system except for the heat generator. The heating terminals are radiators with an operating temperature of 55°C. The use of low temperature terminals (underfloor heating) would allow for double the amount of savings.

# EuroSwitch Function

SPHERA EVO 2.0 provides a useful instrument for maximising savings, for hybrid systems with a gas boiler, through the EuroSwitch function. Based on the set price of natural gas and electricity, the heat pump will assign priority to its own operation rather than that of the boiler depending on its efficiency. The aim is to always use the most cost-effective heat source.

## Case 1 - Typical day in January - Radiators (supply temperature = 55°C)

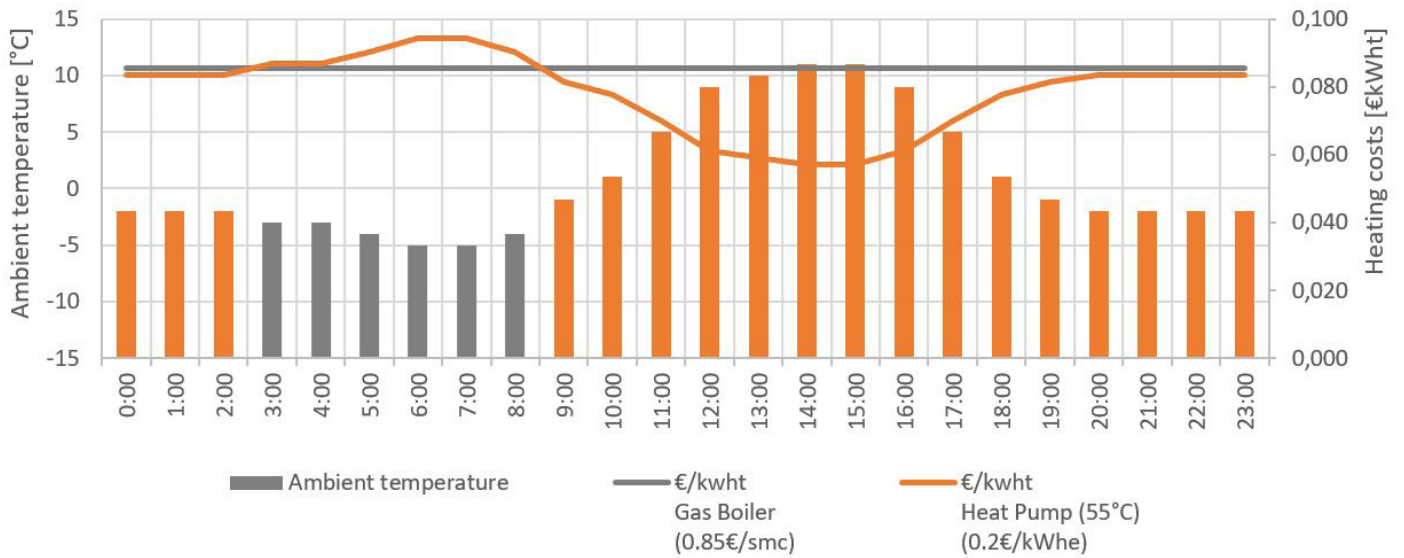

From 03:00am to 08:00am, heat will be produced by the boiler, while during other time slots, it will be produced by the heat pump.

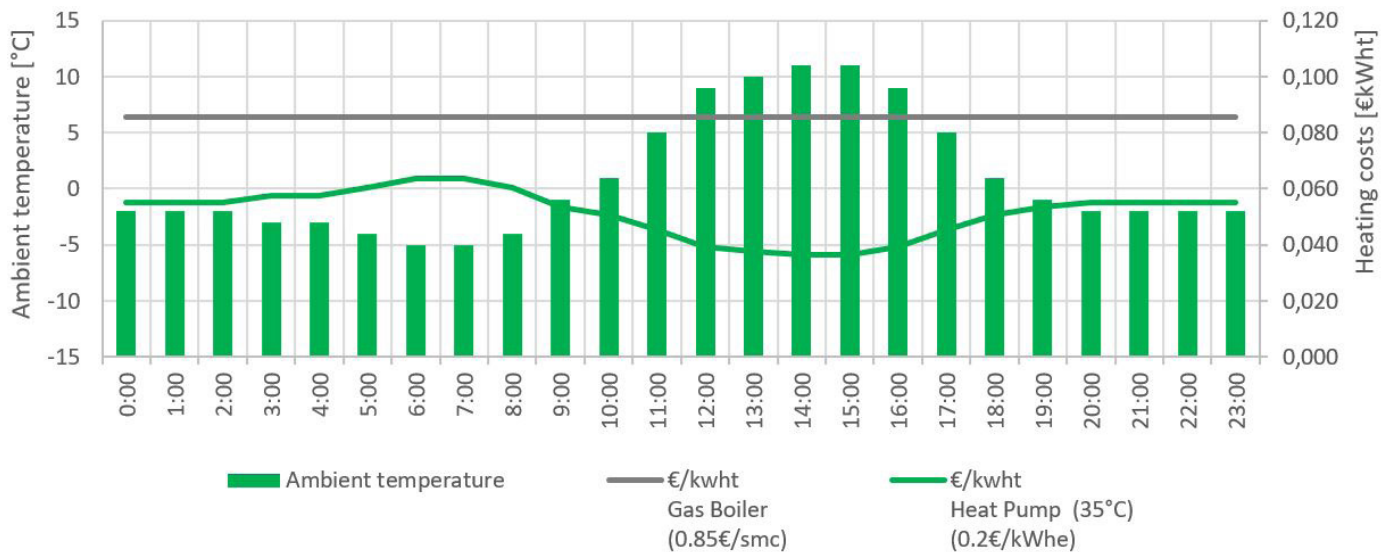

## Case 2 - Typical day in January - Radiant floor (supply temperature = 35°C)

Heat will be produced by the heat pump during the whole day.

The graphs show the trend of the daily temperature and of the cost for thermal energy. The heat pump's efficiency varies according to the outdoor temperature and the water temperature, while the boiler has a fixed efficiency. The calculations consider an average cost of natural gas equal to 0.85 €/SCM and of electricity equal to 0.2 €/SCM.

## SPHERA EVO 2.0 BOX (indoor unit)

DAAGM0001\_00  
DATA/DATE 07/06/2021

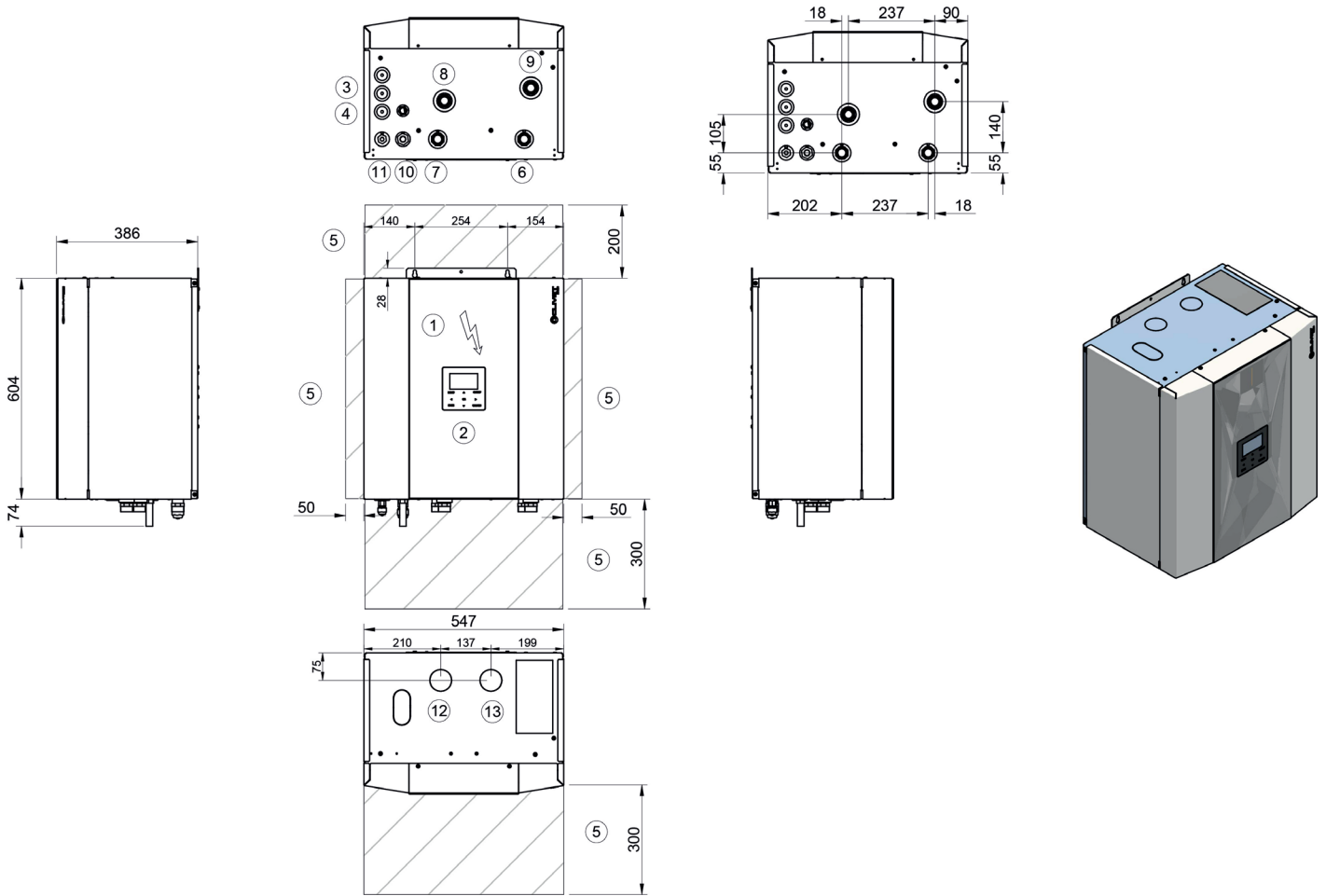

1. Electrical panel
2. Unit control keypad
3. Power input
4. Condensate drain
5. Functional spaces
6. DHW exchanger supply
7. DHW exchanger return
8. System outlet
9. System return
10. 5/8" SAE intake connection
11. 3/8" SAE liquid connection
12. Gas boiler inlet (optional)
13. Gas boiler outlet (optional)

SIZE		GABC	GBBC
Operation weight	kg	52	54
Shipping weight	kg	60	62

The presence of optional accessories may result in a substantial variation of the weights shown in the table.



# Dimensional drawings

## SPHERA EVO 2.0 (outdoor unit) - 2.1 ÷ 3.1

DAAQ80002\_REV00  
DATA/DATE 29/04/2021

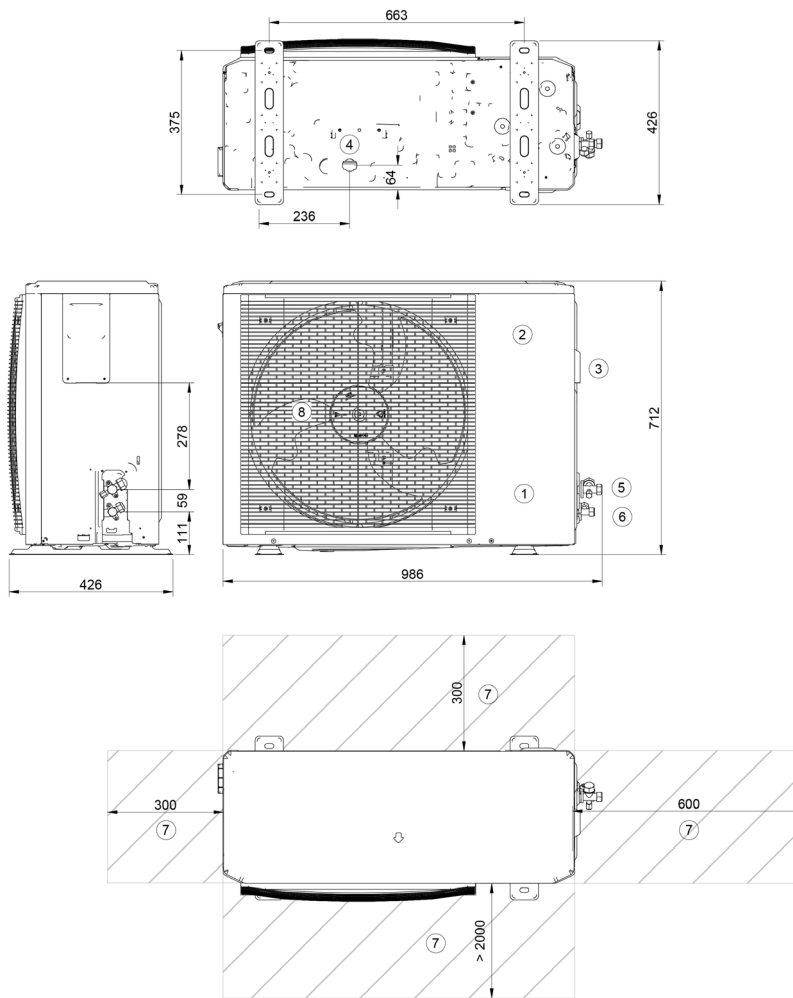

1. Compressor enclosure
2. Electrical panel
3. Power input
4. Condensate drain
5. Gas connections (1/4")
6. Gas connections (5/8")
7. Functional spaces
8. Electrical fan

SIZE		2.1	3.1
Operation weight	kg	58	58
Shipping weight	kg	64	64

The presence of optional accessories may result in a substantial variation of the weights shown in the table.

## SPHERA EVO 2.0 (outdoor unit) - 4.1 ÷ 8.1

DAAQ80001\_REV01  
DATA/DATE 29/01/2021

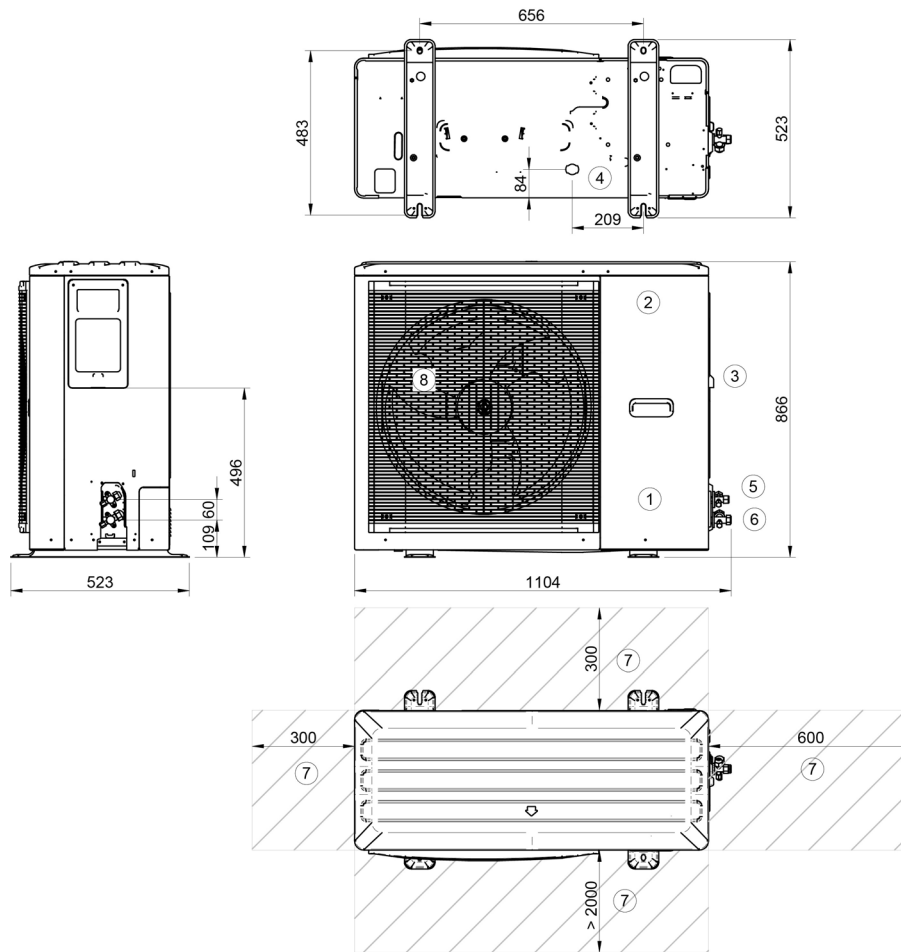

1. Compressor enclosure
2. Electrical panel
3. Power input
4. Condensate drain
5. Gas connections (3/8")
6. Gas connections (5/8")
7. Functional spaces
8. Electrical fan

SIZE		4.1 / 1Ph	5.1 / 1Ph	6.1 / 1Ph	6.1 / 3Ph	7.1 / 1Ph	7.1 / 3Ph	8.1 / 1Ph	8.1 / 3Ph
Operation weight	kg	77	77	96	112	96	112	96	112
Shipping weight	kg	88	88	110	125	110	125	110	125

The presence of optional accessories may result in a substantial variation of the weights shown in the table.

# Dimensional drawings

## GAS BOILER UC

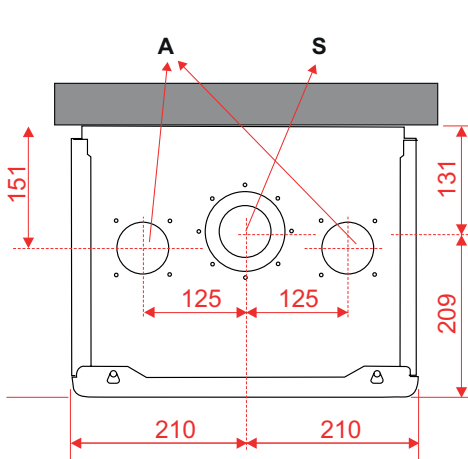
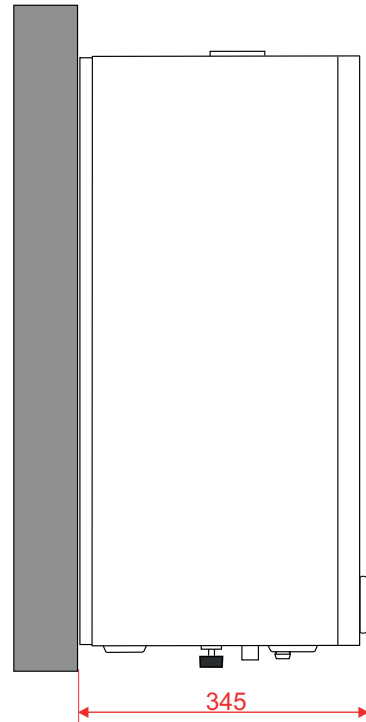
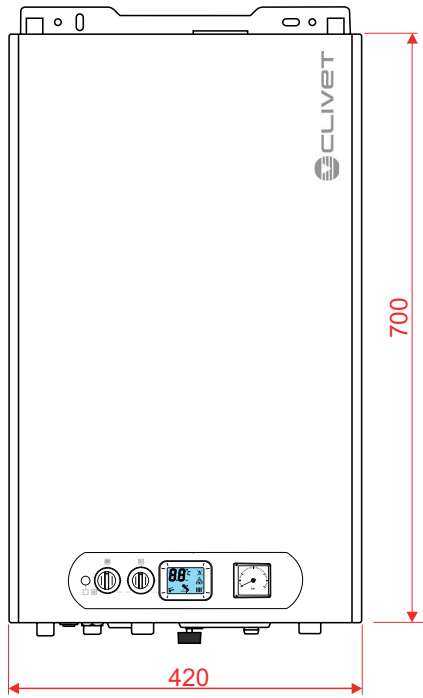

View from above

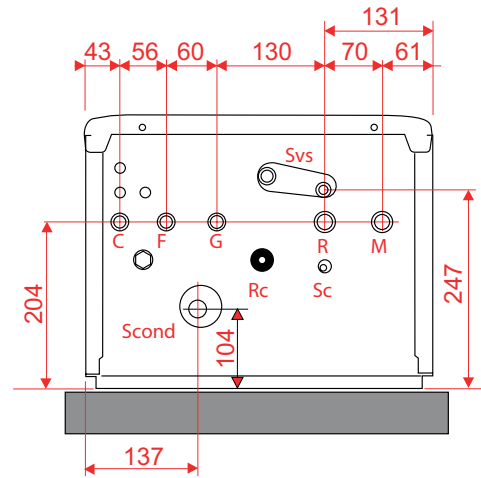

Seen from below

- M = System supply Ø 3/4"
- R = System return Ø 3/4"
- G = Gas Ø 3/4"
- F = Cold DHW inlet Ø 1/2"
- C = Hot DHW outlet Ø 1/2"
- SC = Condensate drain (Ø 18,1)
- A = Air intake Ø 80
- S = Smoke discharge Ø 80

## GAS BOILER FE 24.4

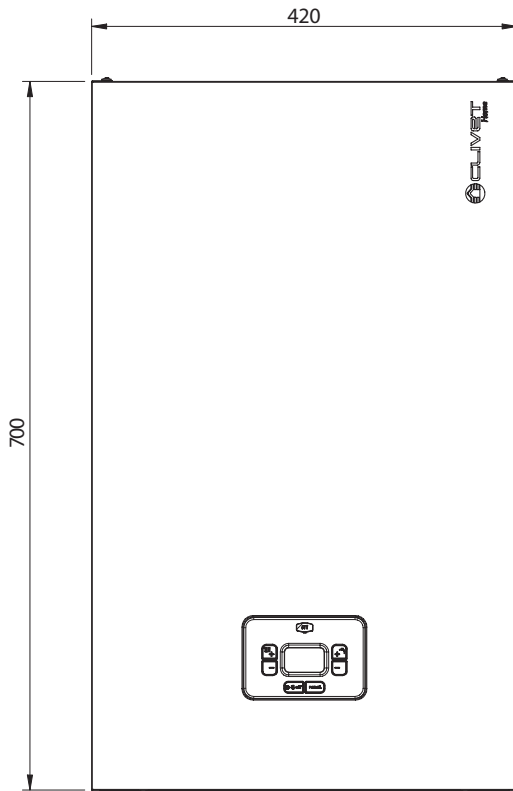

Front view

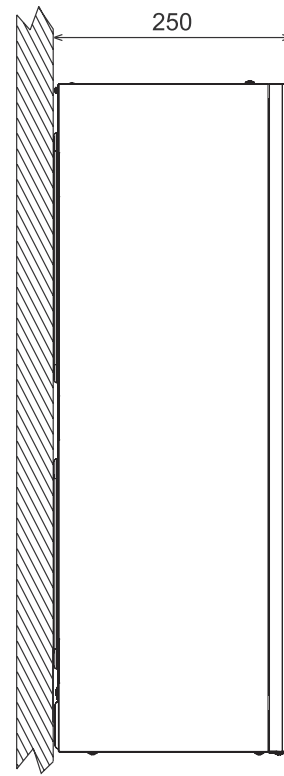

Side view

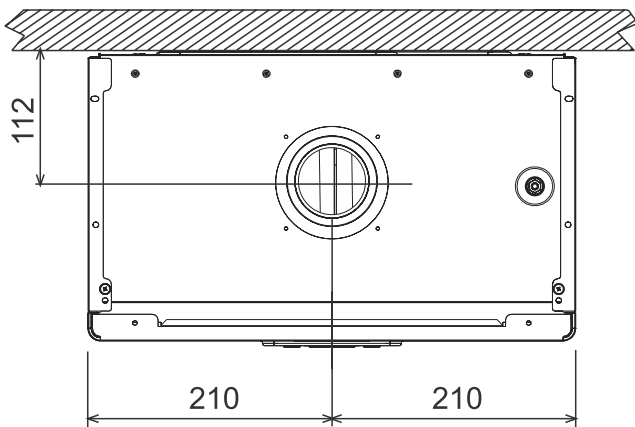

View from above

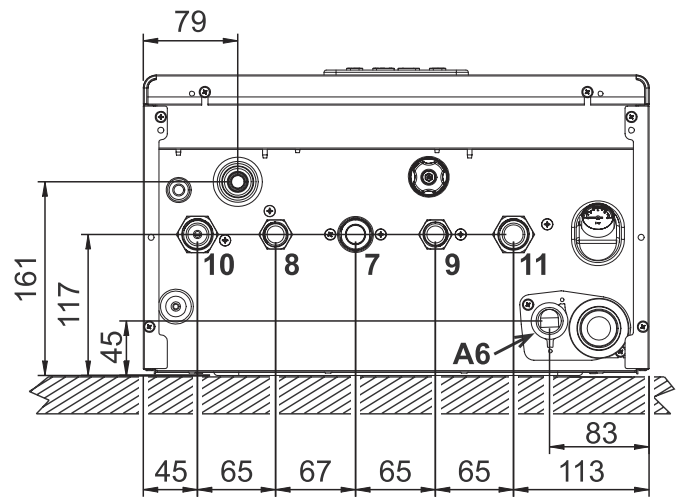

Seen from below

- 10 = System supply  $\varnothing$  3/4"
- 11 = System return  $\varnothing$  3/4"
- 7 = Gas  $\varnothing$  3/4"
- 9 = Cold DHW inlet  $\varnothing$  1/2"
- 8 = Hot DHW outlet  $\varnothing$  1/2"
- A6 = Condensate drain ( $\varnothing$  22,5)
- Air intake and smoke discharge  $\varnothing$  80

# Dimensional drawings

## GAS BOILER FE 33.4

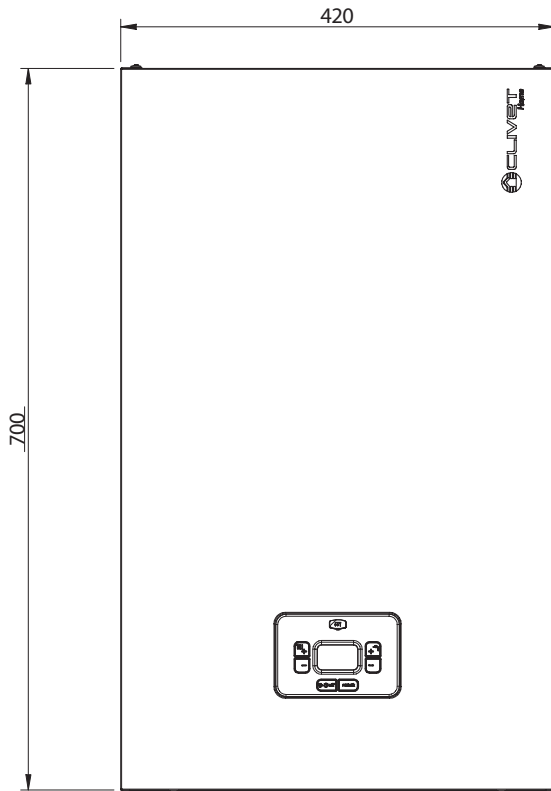

Front view

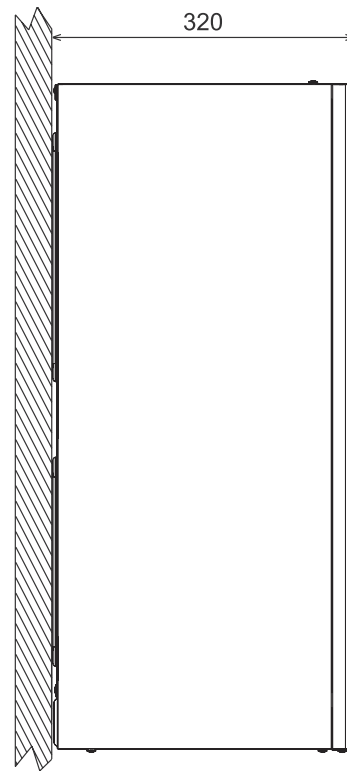

Side view

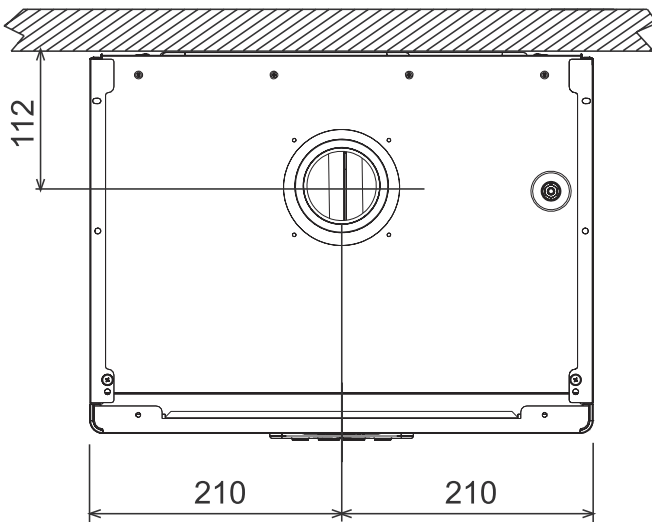

View from above

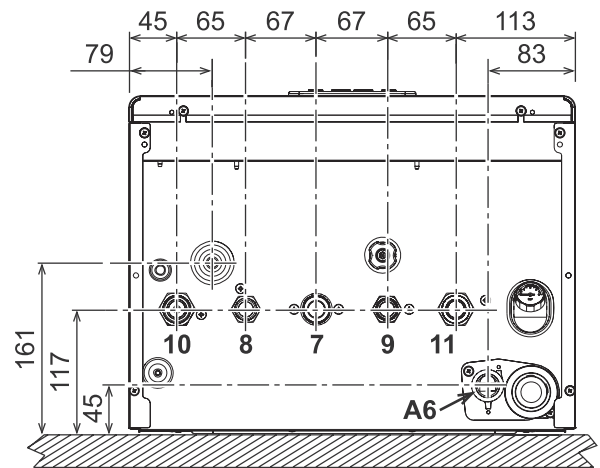

Seen from below

- 10 = System supply  $\varnothing$  3/4"
- 11 = System return  $\varnothing$  3/4"
- 7 = Gas  $\varnothing$  3/4"
- 9 = Cold DHW inlet  $\varnothing$  1/2"
- 8 = Hot DHW outlet  $\varnothing$  1/2"
- A6 = Condensate drain ( $\varnothing$  22,5)
- Air intake and smoke discharge  $\varnothing$  80

Page intentionally left blank

Page intentionally left blank

FOR OVER 30 YEARS WE HAVE BEEN  
OFFERING SOLUTIONS TO ENSURE  
SUSTAINABLE COMFORT AND THE WELL-  
BEING OF PEOPLE AND THE ENVIRONMENT

[www.clivet.com](http://www.clivet.com)

**MideaGroup**  
*humanizing technology*

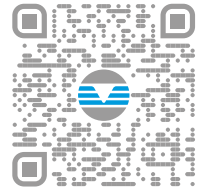

sale and assistance

SPHERA EVO 2.0 Box - BT21F0591--07



**CLIVET S.p.A.**

Via Camp Lonc 25, Z.I. Villapaiera 32032 - Feltre (BL) - Italy  
Tel. +39 0439 3131 - [info@clivet.it](mailto:info@clivet.it)

**CLIVET GMBH**

Hummelsbütteler Steindamm 84,  
22851 Norderstedt, Germany  
Tel. +49 40 325957-0 - [info.de@clivet.com](mailto:info.de@clivet.com)

**Clivet Group UK LTD**

Units F5 & F6 Railway Triangle,  
Portsmouth, Hampshire PO6 1TG  
Tel. +44 02392 381235 -  
[Enquiries@Clivetgroup.co.uk](mailto:Enquiries@Clivetgroup.co.uk)

**CLIVET LLC**

Office 508-511, Elektrozavodskaya st. 24,  
Moscow, Russian Federation, 107023  
Tel. +7495 6462009 - [info.ru@clivet.com](mailto:info.ru@clivet.com)

**CLIVET MIDEAST FZCO**

Dubai Silicon Oasis (DSO) Headquarter Building,  
Office EG-05, P.O Box-342009, Dubai, UAE  
Tel. +9714 3208499 - [info@clivet.ae](mailto:info@clivet.ae)

**Clivet South East Europe**

Jarušćica 9b  
10000, Zagreb, Croatia  
Tel. +3851 222 8784 - [info.see@clivet.com](mailto:info.see@clivet.com)

**CLIVET France**

10, rue du Fort de Saint Cyr - 78180 Montigny le  
Bretonneux, France  
[info.fr@clivet.com](mailto:info.fr@clivet.com)

**Clivet Airconditioning Systems Pvt Ltd**

Office No.501 & 502,5th Floor, Commercial -I,  
Kohinoor City, Old Premier Compound, Off LBS  
Marg, Kirod Road, Kurla West, Mumbai  
Maharashtra 400070, India  
Tel. +91 22 30930200 - [sales.india@clivet.com](mailto:sales.india@clivet.com)