

*Two section air-water heat pump for heating, cooling and DHW production*

## SPHERA EVO 2.0 - Tower

### SQKN-YEE 1 TC + MiSAN-YEE 1 S 2.1 ÷ 8.1 RANGE

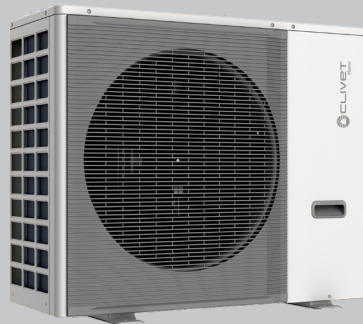
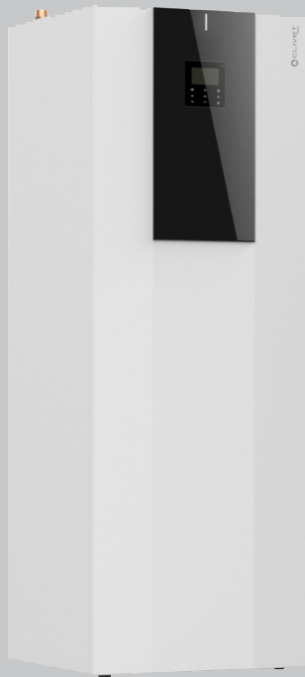

TECHNICAL BULLETIN



SIZE	2.1	3.1	4.1	5.1	6.1	7.1	8.1
HEATING CAPACITY KW	4,32	6,18	8,30	10,9	12,13	14,51	16,01
COOLING CAPACITY KW	4,55	6,44	8,10	10,00	12,06	13,79	14,84

#### DHW STORAGE

190 L - A

250 L - A -B

## Page

---

3	Features and benefits
4	Standard unit technical specifications
6	Built-in options
7	Accessories separately supplied
15	General technical data
29	Refrigerant pipe connection
30	Water connections
31	Electrical connections
32	Fonti di calore ausiliarie e versioni ibride
36	System connections
41	Data for the UNI/TS 11300 calculation
46	Energy requalification
47	EuroSwitch Function
48	Dimensional drawings



Clivet is taking part in the EUROVENT certification programme up to 1.500 kW. The products concerned appear in the certified products list of the EUROVENT [www.eurovent-certification.com](http://www.eurovent-certification.com) site.

# Features and benefits

SPHERA EVO 2.0 is a specialised autonomous heat pump system for single- and multi-family homes with medium/low and high power consumption.

Is an air-water heat pump system for cooling and producing/storing domestic hot water.

The SPHERA EVO 2.0 system is composed of a latest generation high efficiency outdoors moto-condensing unit connected via refrigerant connections to an indoors unit.

It is the second generation of heat pumps for residential use.

## SPHERA EVO 2.0 Tower

- Tower Version
- Two volumes of DHW 190 and 250-litres
- Class A++ Average temperature
- Class A+ Domestic hot water production
- Built-in WiFi for connection to the dedicated APP
- Also available in the hybrid version with 24 kW or 34 kW gas boiler



## SPHERA EVO 2.0 Box

- Box Version
- Integrated 3-way valve for DHW
- Compact dimensions
- Class A+++ Low temperature
- Built-in WiFi for connection to the dedicated APP
- Also available in the hybrid version with 24 kW or 34 kW gas boiler



## SPHERA EVO 2.0 Invisible

- Version for built-in installation
- 50-litre DHW storage can be expanded up to 300-litres
- Compact dimensions for easy installation in walls
- Also available in the hybrid version with 24 kW gas boiler
- Built-in WiFi for connection to the dedicated APP



## SPHERA EVO 2.0 - Tower - Indoor unit

### Zinc-Magnesium frame

Supporting frame in Zinc-Magnesium panelling, excellent mechanical characteristics and high resistance to corrosion over time.

### Panelling

External panelling in zinc-magnesium sheet, with white paint in RAL 9003 to ensure better resistance to corrosion. Panels that can be easily removed to allow full access to internal components.

### Internal exchanger

Direct expansion heat exchanger with INOX AISI 316 stainless steel braze-welded plates. With low refrigerant content and high exchange surface, complete with external anti-condensation thermal insulation 10 mm thick in sintered expanded polypropylene.

### Domestic hot water

- 190-litre or 250-litre DHW storage tank with vitrified internal surface and external polyurethane insulation (50mm thick)
- Magnesium anode
- 2 kW safety and anti-legionella heating element
- Internal exchanger in vitrified steel with an exchange surface of 2 m<sup>2</sup>
- Set-up for domestic hot water recirculation circuit
- Storage discharge stop valve
- Probe sump for solar thermal system control

### Hydronics module

- Variable flow direct current primary circulator
- Safety flow switch for water flow
- 3-way switching valve for system or domestic hot water
- 3 bar system water side pressure relief valve
- Magnetic dirt separator
- System vent valve
- 8 litre system expansion tank, 1 bar pre-charge
- Drain pan in ABS

### Electrical panel

The electrical panel is located inside the unit and is easily accessible thanks to removable panel. Moreover, a LED on the front panel is connected to check the operating status of the unit.

The capacity section includes:

- power input terminals.

The control section includes:

- remote microprocessor control with single-area thermostat function;
- BMS management;
- daily, weekly temperature set point and start-up/shutdown scheduler;
- anti-legionella function scheduling;
- management busters two zones;
- solar thermal management;
- management for auxiliary heaters;
- antifreeze protection water side;
- no water flow-rate protection with flow switch;
- remote interface terminal with graphic display;
- cascade operation.
- Inside the electrical panel there is a T1B temperature probe for low temperature area control in the 2-area kit (length 4.5 m and 6 mm bulb).

### Standard unit kit:

- Mesh filter for system water
- Copper gas reduction for 4-6 kW outdoor unit connection
- Fittings for unit connection
- Ball shut-off valve for system isolation
- Torx key and insert for opening and closing the unit's panels
- Adjustable feet that can be screwed on the base of the unit
- Cover cap for remotely controlled keypad



# Standard unit technical specifications

## SPHERA EVO 2.0 - Outdoor unit

### Zinc-Magnesium frame

High strength frame for outstanding durability and excellent mechanical characteristics.

### Panelling

Outer panelling made of Zinc-Magnesium sheet metal painted with pantone warm gray 2C to ensure superior corrosion resistance. Each panel can be easily removed to allow full access to internal components.

### Rotary DC inverter compressor

Inverter controlled rotary hermetic compressor for constant modulation of the power supplied according to actual needs, ensuring high seasonal efficiency. With a motor protection device for overheating, overcurrents and excessive temperatures of the supply gas. It is installed on anti-vibration mounts and it is equipped with oil charge. The compressor is wrapped by a sound-absorbing hood, that reduces its sound emissions. A guard heater with automatic insertion prevents the refrigerant from diluting the oil when the compressor stops.

### EC inverter fan

Axial fan with variable speed control and sickle shaped blades in ABS resin. It is directly coupled to the electronically controlled motor (IP23), which, thanks to brushless technology and the particular power supply, increases its lifespan and reduces consumption. The fan is housed in an aerodynamically shaped nozzle to increase efficiency and minimise noise. It is also fitted with anti-intrusion grid.

### External exchanger

Direct expansion finned coil exchanger made with copper pipes mechanically expanded to better adhere to the fin collar. It has a large surface area to improve heat exchange and reduce defrosting in the interest of seasonal efficiency. The fins are made of aluminium with hydrophilic treatment which facilitates the elimination of condensate, further improving defrosting.

### Refrigerant circuit

The refrigeration circuit includes:

- Electronic expansion valve
- 4-way cycle inversion valve
- Liquid separator in extraction
- Mechanical filters
- Low pressure pressure switch
- High pressure pressure switch



## **EH024**

### **Integration electric heater**

#### **EH3**

The electric heater can operate both for the system and for the production of domestic hot water in two different modes:

#### **EH6**

#### **EH9**

- as an integration, when the heat pump capacity is not enough to fulfil the required set point;
- as a safety element if the heat pump fails.

- ⚠ The additional electric heater is not an accessory supplied separately, but a construction configuration.
- ⚠ Selection of the additional three-phase (6 e 9kW) electric heater changes the voltage of the indoor unit only. The outdoor unit remains with single phase power supply.
- ⚠ Selection of the additional three-phase electric heater changes the voltage of the indoor unit only. The outdoor unit remains with single phase power supply.



# Accessories separately supplied

**KIRE2HX -  
KIRE2HLX**

**2 zones: external kit, both at high temperature**

**2 zones: external kit, high temperature + low temperature (mixed)**

Distribution module for 2-zone heating systems with compact design (402mm x 250mm x h525mm) and ample versatility for different types of installation.

Kit composed of:

- 1 collector / Black painted separator;
- 2 circulator;
- 1 sliding temperature mixing valve (only for the kit KIRE2HL);
- 1 EPP insulation (front and rear);
- 1 threaded disc with hermetic sealing cap;
- 1 lower anti-rotation jig;
- 1 support bracket module,
- 1 sonda per la gestione della temperatura del circuito miscelato

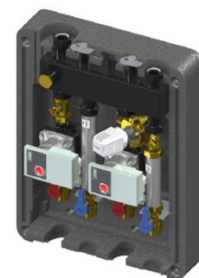

For the technical data of the hydraulic head of the pumps, please refer to the dedicated section in the HYDRAULIC DATA chapter.

**KCSX**

**Secondary circuit kit (1-litre circuit breaker + pump)**

The single-zone kit consists of a DIX hydraulic separator combined with a high efficiency pump, all inside a box for easy installation. Allows interaction between the primary circuit circulator and the secondary circuit circulator. Furthermore, the separator also has the function of a deaerator. With the following benefits and advantages:

- makes the connected hydraulic circuits independent;
- ensures effective operation of the secondary circulator that provides the hydraulic demand of air conditioning systems
- air extraction system;
- thermally insulated black EPP
- zone manifold connection kit

The kit is comprised of:

- 1 1-litre circuit breaker;
- 2 copper pipes;
- 1 circulator;
- closing plates

Dimensions:  
Length 457 mm  
Height 457 mm  
Depth 133 mm



## DIMENSIONAL

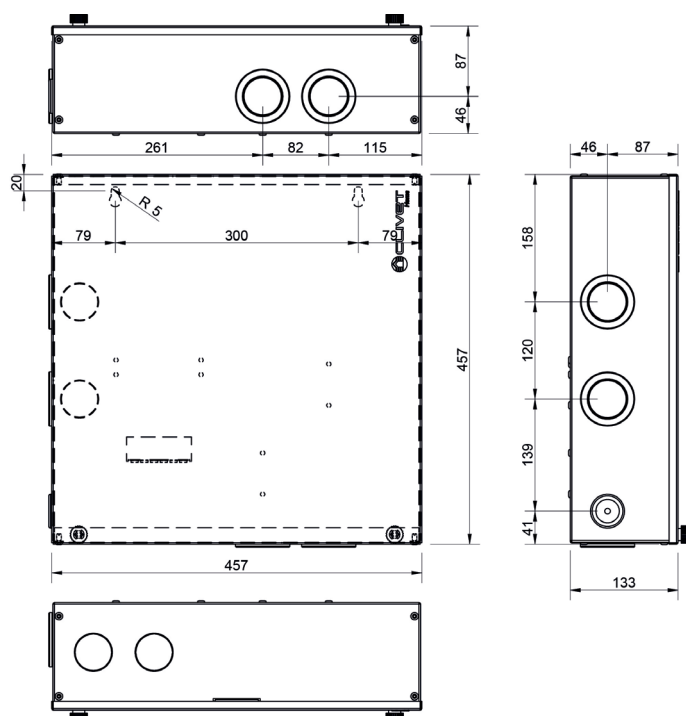

## DIX 1-litre circuit braker

The CP60 hydraulic separator is a compensation chamber designed to make connected hydraulic circuits independent. It is used when the circulator of the primary circuit interacts with one or more parts of the secondary circuit in the same system. Furthermore, the separator performs the function of a deaerator.

With the following benefits and advantages:

- makes the connected hydraulic circuits independent;
- ensures effective operation of the secondary circulators that provide the hydraulic demand of air conditioning systems
- air extraction system;
- thermally insulated black EPP
- zone manifold connection kit

Technical data:

Nominal diameter DN 20

Connection 1" F

Max overall dimensions 120 x 420 x 945

Max temperature 110°C

Max pressure 6 bar

Circuit breaker material S235 steel

Insulation material EPP (40 g/l)

Insulation thickness 20 mm

The kit is supplied with a plate for wall mounting



## DIMENSIONAL

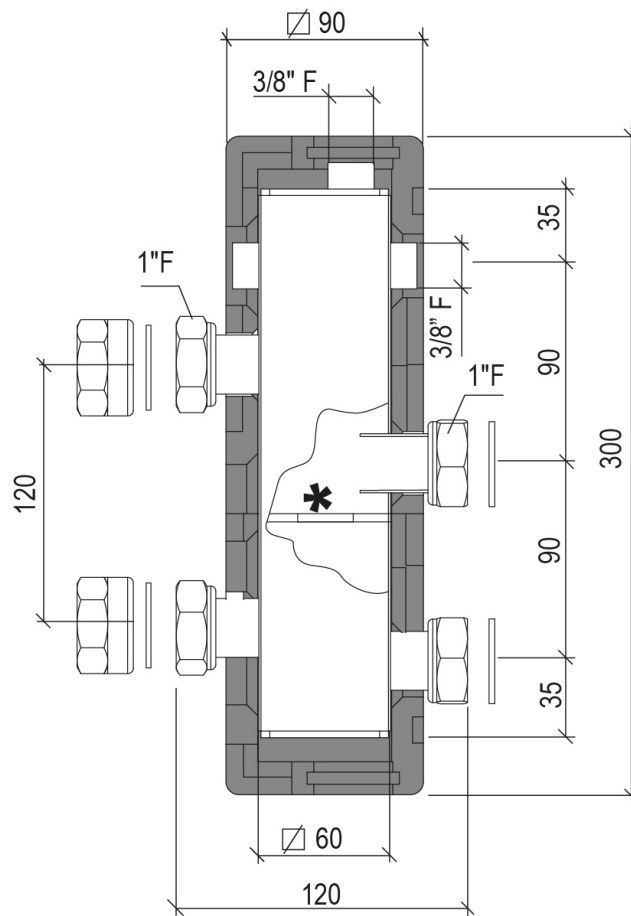



# Accessories separately supplied

## DI50X

### 50-litre circuit breaker

Technical 50-litre storage tank with the function of a hydraulic separator and inertial tank ensures effective operation of the secondary circulators that provide the hydraulic demand of air conditioning systems. With the possibility of connecting two zones.

Technical data:

Circuit breaker diameter 380 mm

Circuit breaker height 933 mm

Connections 1" 1/4 F

Max temperature 95°C

Max pressure 6 bar

Circuit breaker material S235JR steel

Circuit breaker capacity 57 litres

Circuit breaker weight 25 kg

Insulation material Polyurethane foam

Insulation thickness 40 mm

Energy class B

Specific heat loss 0.76 W/K

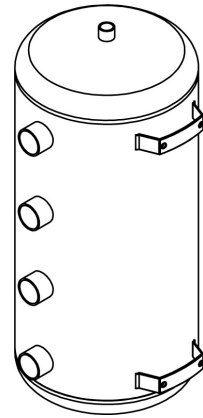

The kit is supplied with brackets for wall mounting.

### DIMENSIONAL

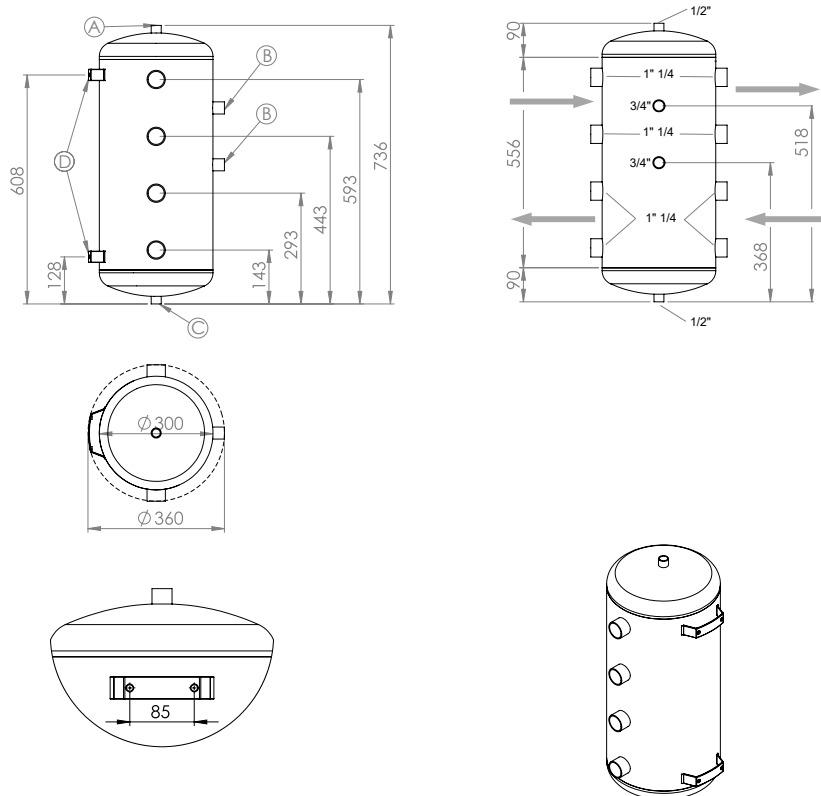

## ACSA250X 250L additional domestic hot water storage tank

Additional storage tank to increase the available amount of domestic hot water.

The kit includes:

- 250-litre DHW storage tank in vitrified steel with external polyurethane insulation (50mm thick) and magnesium anode;
- circulation pump, ensures both storage tanks are at the same temperature;
- 16-litre DHW side expansion tank, 1.5 bar pre-charge;
- DHW side pressure relief valve set at 6 bar;
- anti-scalding thermostatic valve;
- set-up for DHW recirculation (recirculation pump not included);
- drain pan;
- temperature probe for additional storage tank;
- storage tank drain valve.

For the technical characteristics of the storage tank, use those of the standard 250L storage tank

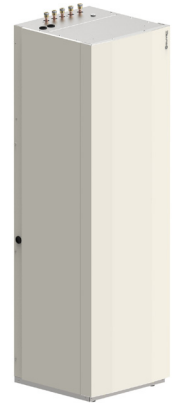

### DIMENSIONAL

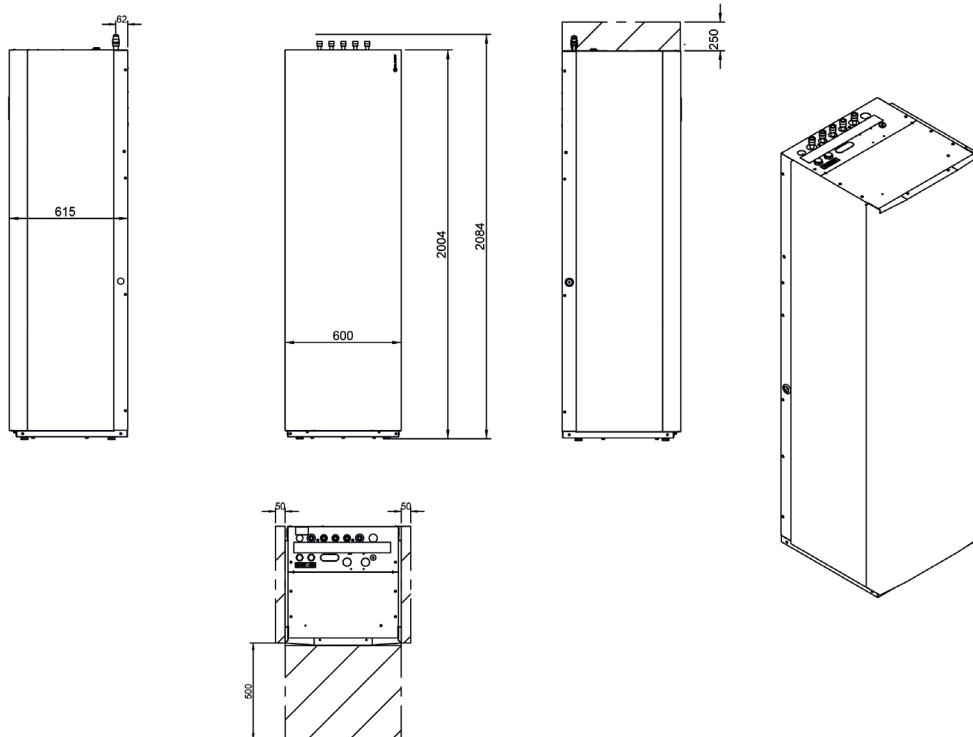

## ACI40X 40L system inertial storage tank

Inertial storage tank to be installed outside the unit. Extremely compact, supplied with air vents and support brackets for wall installation. Suitable for all SPHERA EVO 2.0 sizes, it facilitates operation and helps to fulfil the heat requirement, guaranteeing optimal modulation.

It can be installed next to or behind the unit, as shown in the figure.

Kit consisting of:

- 140-litre ST371 steel storage tank for ACI40X
- 12-metre flexible hose
- Extremely compact:  
LENGTH: 440 mm  
DEPTH: 220 mm  
HEIGHT: 887 mm
- Maximum working temperature: 100°C
- Maximum operating pressure: 6 bar
- Thermally-isolated with EPP 40 g/l
- Insulation thickness 30 mm
- Automatic air vent

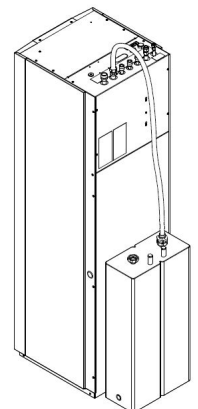

# Accessories separately supplied

## COFX

### Casing sheets for the inertial storage cover

Decorative metal sheets serving as a cover for the inertial storage tank, if installed at the back of the unit.



## SOLX

### Drain-back solar integration for domestic hot water

The kit, which can be installed inside the unit, consists of:

- 1 Brazed plate heat exchanger in stainless steel (AISI 316) for domestic hot water production
- 1 Circulator
- 1 Exchanger support
- Copper connection pipes
- 2 plastic supports

In this case, a solar system circulation unit must be hooked up; this can be installed outside the unit. For the components and sizing of the system of solar collectors, refer to the ELFOSun technical documentation.

A 2kW heating element is submerged in the tank which operates when the refrigeration system fails or to complete the anti-legionella cycle as a backup for the compressor.

For proper operation, the solar panel controller's temperature sensor must be installed in the SPHERA EVO 2.0 storage tank sump.

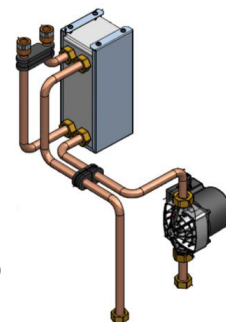

### Solar heat exchanger pressure drop

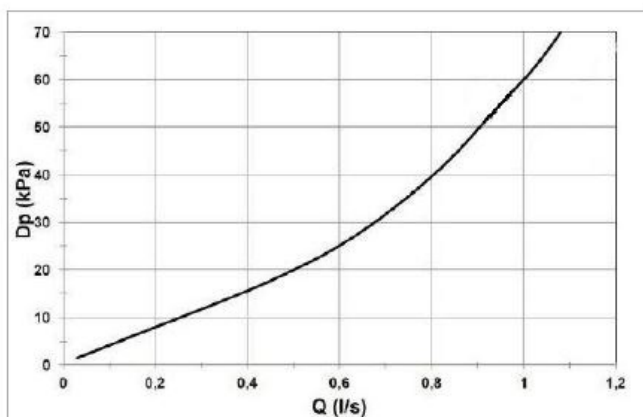

⚠ The solar integration for DHW excludes the configuration with an additional electrical heater, the external boiler connection kit.

## KCCEX

### External boiler connection kit

Kit offering the option to connect the water circuit to an external boiler.

The latter, to be provided by the customer, must have a clean ON/OFF contact.

The internal logics of SPHERA EVO 2.0 permit use of the boiler both together with or instead of the heat pump for greater comfort even at the coldest temperatures.

Kit composed of:

- 1 three-way valve with microswitch for ON/OFF activation of the boiler;
- copper pipes for connection;
- plastic seals;
- terminals and cables for electrical connections;
- kit installation manual.

⚠ The external boiler connection kit excludes configuration with additional electric heater.

⚠ Check that the boiler pressure drops are compatible with the head of the unit.

⚠ Not required for SPHERA EVO 2.0 Tower Hybrid version

**HID-TCXB** **Black soft touch chronothermostat, with temperature control and management via App / Voice control**  
**HID-TCXN** **White soft touch chronothermostat, with temperature control and management via App / Voice control**

For semi-uncased installation

Main functions available from the thermostat:

- ON/OFF
- keypad lock
- set-point control and limitation
- room temperature display
- setting change (manual / scheduled)
- antifreeze function (prevents temperatures that are too low)

Additional functions available on the Clivet Home Connect App

- weekly schedule
- boost (forced system switch-on)
- temperature and consumptions log

Technical specifications:

- display: colour soft-touch
- combinable SwitchConnect receivers: max 2
- installation: semi-uncased
- power supply: 100÷253V / 50÷60Hz
- settable temperature: 5÷40°C
- antifreeze temperature: 2÷25°C
- temperature offset: ±5°C (std 0°C)
- protection rating: IP30
- Wi-Fi: 802.11 b/g/n
- self-adjusting clock via web with back-up battery
- dimensions: 122x82x15mm



## **SWCX** **SwitchConnect radio receiver**

Radio receiver for HID-TConnect, for managing the request of terminal units or radiant systems, the heat pump mode change or the double set-point.

Technical specifications:

- functions: radio receiver for use with HID-TConnect
- combinable thermostats: max 6
- frequency: 2.4GHz
- transmission distance: max 30m (in buildings) / max 100m (in open range)
- contacts: 2 relays (voltage-free)
- power supply: 95÷290V / 47÷440Hz
- operation temperature: 0÷40°C
- operation humidity: 20÷80% RH
- dimensions: 125x78x30.5mm



## **SFCSTX** **Additional probe for cascade function**

Temperature sensor to manage the setpoint for units connected in cascade

# Accessories separately supplied

## DTX Auxiliary drain pan

### Outdoor unit

The base plate of the outdoor unit is fitted with a drain for the condensate produced during the winter phase in the defrosting period. This can help (not guarantee) condensate flow correctly into the relevant drains.

To ensure the condensate is drained correctly, in the various operating conditions it is mandatory to use the auxiliary condensate drain pan with drainage to be connected to the drain trap, according to the relevant technical standards and regulations in force.

An anti-freeze heater is also included in the drain pan. It prevents the condensate produced from freezing when the outdoor temperature drops below zero.



## APAVX Kit of antivibration mounts for floor installation

The antivibration mounts for floor installation reduce the vibrations of the compressor during its operation. They are secured to the feet of the base plate.



## ASTFX Kit of antivibration mounts for wall bracket installation

The antivibration mounts reduce the vibrations of the compressor during its operation. They are secured to the wall support brackets.



## KSIPX Kit with wall fixing brackets

Wall fixing bracket for outdoor unit, adjustable, in galvanised steel painted with polyester powders for outdoor use..

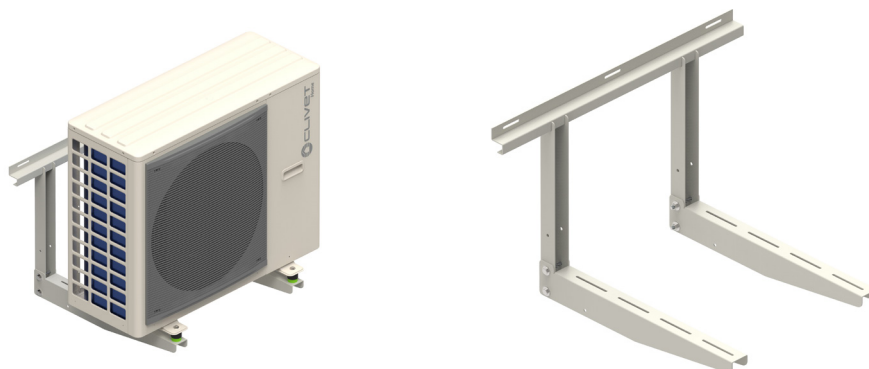

## VDACSX Thermostatic switching valve for DHW

The thermostatic switching valve is used in the DHW circuit.

It is designed to divert the water from the DHW storage tank directly to the utility as the water temperature is suitable for use. If the temperature is not adequate for direct use, the switching valve ensures the water passes inside the boiler which, thanks to instant production, guarantees continuous supply.

1 1/4 "M connections.

Body in anti-dezincification alloy. Chromium-plated.

PSU shutter.

Stainless steel springs.

EPDM sealing elements.

Maximum inlet temperature 100°C.

Adjustment range: 38÷52°C

Accuracy: ± 2°C

Max (static) working pressure: 10 bar

Max (dynamic) working pressure: 5 bar

Default calibration: 40°C

Minimum range for steady operation: 4 l/min



⚠ Reductions for connections of different diameters are the responsibility of the client

# Accessories separately supplied

**HYUC24 Hybrid solution with 24kW 4-pipe boiler (GAS BOILER UC 24.4)**

**HYUC34 Hybrid solution with 34kW 4-pipe boiler (GAS BOILER UC 33.4)**

**HYFE24 Hybrid solution with 24kW 4-pipe boiler (GAS BOILER FE 24.4)**

**HYFE34 Hybrid solution with 34kW 4-pipe boiler (GAS BOILER FE 33.4)**

Boiler to be combined with hybrid version heat pump, making a system designed to work with the boiler as a support, replacement or back-up for the heat pump.

The boiler can produce DHW instantaneously, allowing simultaneous heating or cooling operation by the heat pump.

The heat pump manages and optimises the system by means of a water temperature probe (T1) located on the boiler supply line.

**The kit includes:**

- 24kW or 34kW condensing boiler
- 10 m long temperature probe (T1)



Gas Boiler UC



Gas Boiler FE

Note: all boiler versions are prepared for the connection of smoke intake/discharge fittings, which must be selected separately according to the installation required.

All boiler versions are standard supplied ready for methane or LPG operation. The UC versions require a pressure reducer to be fitted on site to the nozzle, which is standard supplied with the boiler. Refer to the manual for further details.

**⚠** The hybrid solution excludes the possibility of selecting electric heaters in the system.

## Accessories available for boilers

**KCSAFX Vertical coaxial fitting ø 60/100mm**

Vertical coaxial flanged polypropylene fitting, 60/100mm diameter, which allows combustion gas discharge and air intake by means of two coaxial ducts.



**CCOAX 90 ° coaxial curve for horizontal outlet ø 60 / 100mm adjustable 360°**

Curve for smoke discharge and air intake, combinable with ø 60/100 coaxial pipe with terminal.

The internal section is used for the discharge of the combustion gas while the external section is used for the intake of combustion air.



**TCOAX Coaxial pipe L = 1000mm ø 60/100 with terminal**

Pipe for smoke discharge and air intake through an external wall with exhaust terminal.

The internal section is used for the discharge of the combustion gas while the external section is used for the intake of combustion air.



**KAS80X Vertical fittings ø 80mm**

Two vertical flanged polypropylene fittings, 80mm diameter, with inspection ports, which allow the combustion gas discharge and air intake to be split directly from the boiler body.

**⚠** Compatible only with GAS BOILER UC



**KSDFX Smoke discharge splitter kit ø 80mm**

Polypropylene kit to split the air intake and the smoke discharge into two 80mm connections with inspection inlets to connect to vertical or bent pipes

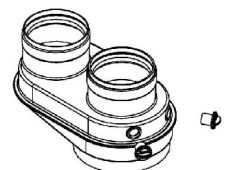

# General technical data

## Prestazioni

SIZE	2.1		3.1		4.1		5.1		6.1*	7.1*	8.1*		
<b>STORAGE TANK CAPACITY</b>	190 L	250 L	190 L	250 L	190 L	250 L	190 L	250 L	250 L	250 L	250 L		
<b>Heating</b>													
<b>Air 7°C - Water 35°C</b>													
Nominal heating capacity / Max	1	kW	4,32 / 6,26	6,18 / 7,41	8,30 / 9,11	10,09 / 10,3	12,13 / 14,60	14,51 / 15,5	16,01 / 16,80				
Total power input	1	kW	0,80	1,19	1,56	2,01	2,42	3,09	3,52				
COP	1	-	5,42	5,21	5,31	5,01	5,00	4,70	4,55				
Water flow-rate	1	l/s	0,21	0,30	0,41	0,49	0,57	0,67	0,75				
Nominal available pressure	1	kPa	31,2	36,5	33,1	31,0	25,7	31,7	22,6				
Maximum available pressure	1	kPa	69	95	62	90	47	83	31	76	70	55	39
<b>Air -7°C - Water 35°C</b>													
Nominal heating capacity / Max	2	kW	4,17 / 6,25	6,05 / 6,97	7,33 / 8,35	8,20 / 9,30	10,49 / 13,85	12,23 / 14,09	13,43 / 14,33				
Total power input	2	kW	1,32	2,01	2,27	2,67	3,36	4,33	4,90				
COP	2	-	3,16	3,00	3,23	3,07	3,13	2,82	2,74				
Water flow-rate	2	l/s	0,22	0,29	0,34	0,40	0,56	0,62	0,70				
Nominal available pressure	2	kPa	35,0	39,8	34,0	31,7	65,8	63,1	47,7				
Maximum available pressure	2	kPa	69	94	64	91	58	88	49	84	71	63	49
<b>Air 7°C - Water 45°C</b>													
Nominal heating capacity / Max	3	kW	4,16 / 5,96	6,03 / 7,13	8,22 / 8,98	10,01 / 10,30	12,30 / 14,50	14,00 / 15,70	16,01 / 16,60				
Total power input	3	kW	1,06	1,57	2,08	2,59	3,24	3,84	4,45				
COP	3	-	3,93	3,83	3,95	3,86	3,80	3,65	3,60				
Water flow-rate	3	l/s	0,19	0,30	0,39	0,49	0,60	0,67	0,76				
Nominal available pressure	3	kPa	32,3	36,4	34,9	31,0	51,6	41,8	21,7				
Maximum available pressure	3	kPa	70	95	63	90	51	85	31	76	65	55	38
<b>Air 7°C - Water 55°C</b>													
Nominal heating capacity / Max	4	kW	4,08 / 5,74	5,94 / 6,90	7,50 / 7,80	9,60 / 9,72	12,07 / 13,90	13,85 / 14,50	16,00 / 16,20				
Total power input	4	kW	1,36	1,93	2,35	3,10	3,89	4,53	5,52				
COP	4	-	3,00	3,07	3,19	3,10	3,10	3,05	2,90				
Water flow-rate	4	l/s	0,12	0,18	0,23	0,29	0,36	0,41	0,48				
Nominal available pressure	4	kPa	35,6	33,4	31,2	33,6	14,1	16,5	17,4				
Maximum available pressure	4	kPa	70	98	70	96	69	94	63	91	90	105	80
<b>Cooling</b>													
<b>Air 35°C - Water 18°C</b>													
Nominal cooling capacity / max	5	kW	4,55 / 6,88	6,44 / 7,65	8,10 / 11,13	10,00 / 12,03	12,06 / 15,02	13,79 / 15,30	14,84 / 16,38				
Total power input	5	kW	0,75	1,23	1,58	2,10	3,00	3,73	4,07				
EER	5	-	6,08	5,24	5,12	4,77	4,02	3,70	3,65				
Water flow-rate	5	l/s	0,22	0,32	0,38	0,48	0,60	0,63	0,71				
Nominal available pressure	5	kPa	34,9	34,8	34,6	10,6	13,1	16,3	15,1				
Maximum available pressure	5	kPa	69	94	61	89	51	85	32	76	65	61	48
<b>Air 35°C - Water 7°C</b>													
Nominal cooling capacity / max	6	kW	4,26 / 6,14	6,25 / 6,39	7,46 / 7,94	8,67 / 9,10	11,16 / 11,80	11,72 / 12,86	12,88 / 14,2				
Total power input	6	kW	1,22	2,02	2,24	2,94	4,29	5,04	5,80				
EER	6	-	3,50	3,09	3,33	3,09	2,75	2,55	2,45				
Water flow-rate	6	l/s	0,20	0,29	0,36	0,43	0,54	0,59	0,64				
Nominal available pressure	6	kPa	5,8	36,1	34,3	36,8	18,1	20,3	25,1				
Maximum available pressure	6	kPa	70	95	64	91	56	87	43	82	74	67	60

1. User side entering/leaving water temperature 30/35 °C, source side air 7°C (U.R. = 85% Heat power data, Total power input and COP in accordance with EN 14511:2018.
2. User side entering/leaving water temperature 30/35 °C, source side air -7°C Heat power data, Total power input and COP in accordance with EN 14511:2018.
3. User side entering/leaving water temperature 40/45 °C, source side air 7°C (U.R. = 85% Heat power data, Total power input and COP in accordance with EN 14511:2018.
4. User side entering/leaving water temperature 18/23 °C, source side air 35°C Heat power data, Total power input and COP in accordance with EN 14511:2018.
5. User side entering/leaving water temperature 7/12 °C, source side air 35°C Heat power data, Total power input and COP in accordance with EN 14511:2018.
6. The product is conforming with the European ErP Directives, which includes Commission Delegated Regulation (EU) N. 811/2018 and Commission Delegated Regulation N. 813/2013, Clima Average, High Temperature 47/55°C.

All data calculated with zero elevation gain and equivalent length of 7m.

SIZE			2.1		3.1		4.1		5.1		6.1*		7.1*		8.1*	
<b>STORAGE TANK CAPACITY</b>			190 L	250 L	190 L	250 L	190 L	250 L	190 L	250 L	250 L	250 L	250 L	250 L	250 L	250 L
<b>ERP</b>																
<b>Clima Average High temperature Heat pumps</b>																
Nominal power	7	kW	4		6		7		9		12		13		13	
SCOP	7	-	3.32		3.54		3.72		3.73		3.56		3.52		3.48	
Generator energy class	7	-	A++		A++		A++		A++		A++		A++		A++	
$\eta_s$	7	%	130		138		146		146		139		138		136	
System energy class	7	-	A++		A++		A++		A++		A++		A++		A++	
$\eta_s$	7	%	135		143		151		151		144		143		141	
<b>Clima Average Low temperature Heat pumps</b>																
Nominal power	8	kW	5		6		8		10		12		14		16	
SCOP	8	-	5,13		5,15		5.32		5.27		5.00		4.91		4.89	
Generator energy class	8	-	A+++		A+++		A+++		A+++		A+++		A+++		A+++	
$\eta_s$	8	%	202		203		210		208		196		193		193	
System energy class	8	-	A+++		A+++		A+++		A+++		A+++		A+++		A+++	
$\eta_s$	8	%	207		208		215		213		201		198		198	
<b>Average climatic conditions - Heat pump for application with Fan coil</b>																
Nominal power	9	kW	4		6		7		9		12		13		14	
SEER	9	-	5,09		5,42		5.95		6.01		5.16		5.10		4.87	
Generator energy class	9	-	A+++		A+++		A+++		A+++		A+++		A+++		A+++	
$\eta_s$	9	%	201		214		235		238		203		201		192	
<b>Heat pump for Domestic Hot Water application</b>																
Load profile declared	10	-	L	XL	L	XL	L	XL	L	XL	XL	XL	XL	XL	XL	XL
$\eta_{wh}$	10	%	120	123	120	123	116	125	116	125	124	124	124	124	124	124
Sanitary water energy class	10	-	A+	A+	A+	A+	A+	A+	A+	A+	A+	A+	A+	A+	A+	A+

- The product is conforming with the European ErP Directives, which includes Commission Delegated Regulation (EU) N. 811/2018 and Commission Delegated Regulation N. 813/2013. Clima Average, Medium temperature 47/55°C
- The product is conforming with the European ErP Directives, which includes Commission Delegated Regulation (EU) N. 811/2018 and Commission Delegated Regulation N. 813/2013. Clima Average, Low temperature 30/35°C
- The product is conforming with the European ErP Directives, which includes Commission Delegated Regulation (EU) N. 811/2018 and Commission Delegated Regulation N. 813/2013. Clima Average, Low temperature 12/7°C
- Data according to EN 16147: 2017

All data calculated with zero elevation gain and equivalent length of 7m..

## Construction - Outdoor unit

SIZE			2.1		3.1		4.1		5.1		6.1		7.1		8.1	
<b>Characteristics</b>																
Compressor	Twin Rotary															
Refrigerant	R32															
Refrigerant charge	kg		1.50		1.50		1.65		1.65		1.84		1.84		1.84	
GWP	$t_{CO_2}$		675		675		675		675		675		675		675	
Equivalent tons of CO2 (*)	$t_e$		1.02		1.02		1.11		1,11		1.24		1.24		1.24	
Oil charge	l		0,46		0,46		0,46		0,46		1,10		1,10		1,10	
Type of fan	Axial															
Nominal air flow rate	$m^3/h$		2770		2770		4030		4030		4060		4060		4060	
Outdoors unit sound pressure at 1 metre	1	dB(A)	42		44		45		47		50		51		53	
Sound power	1	dB(A)	55		57		58		60		63		64		66	
<b>Dimensions</b>																
Operation (L x P x A)	mm		986x426x712		986x426x712		1140x523x866		1140x523x866		1140x523x866		1140x523x866		1140x523x866	
Packing (L x P x A)	mm		1065x485x800		1065x485x800		1180x560x890		1180x560x890		1180x560x890		1180x560x890		1180x560x890	
Operation weight 230M / 400TN	2	kg	58		58		77		77		96/112		96/112		96/112	
Shipping weight 230M / 400TN	2	kg	64		64		88		88		110/125		110/125		110/125	

- Sound pressure level determined using the intense metric method (UNI EN ISO 9614-2). The sound levels are referred to a unit at full load, under nominal test conditions. Data referred to the following conditions: service side exchanger inlet/outlet water 47/55 °C source side exchanger inlet air 7°C. The sound pressure level refers to a distance of 1 m from the external surface of the unit operating in the free field.
  - Power supply 220-240V ~ 50Hz / Power supply 380-415V 3N~ 50Hz
- (\*) It contains fluorinated greenhouse gases.



# General technical data

## Construction - Indoor unit

SIZE			A - 190 L	A - 250 L	B - 250 L
<b>System characteristics</b>					
Maximum circuit pressure		bar	3,0	3,0	3,0
System expansion tank	1	l	8,0	8,0	8,0
Preload expansion tank		bar	1,0	1,0	1,0
System water connections		inch	1"	1"	1"
<b>DHW characteristics</b>					
Type Storage tank			Enameled steel	Enameled steel	Enameled steel
Volume of DHW tank		l	190	250	250
Internal pipe coil exchange surface		m <sup>2</sup>	2,0	2,0	2,0
Storage dispersion		W/K ( kWh/24h)	1.81 (1.95)	2.04 (2.20)	2.04 (2.20)
DHW safety heating element		kW	2,0	2,0	2,0
Maximum DHW circuit pressure	2	bar	10,0	10,0	10,0
Recommended sanitary expansion tank	3	l	12,0	16,0	16,0
DHW water connections		inch	3/4"	3/4"	3/4"
<b>Dimensions</b>					
Operation (L x P x A)		mm	600 x 615 x 1774	600 x 615 x 2084	600 x 615 x 2084
Packing (L x P x A)		mm	660 x 690 x 1890	660 x 690 x 2190	660 x 690 x 2190
Operation weight		kg	359	419	421
Shipping weight		kg	187	192	194

1. Sufficient volume up to a maximum of 60 litres of system water content.
2. The installation of the sanitary side safety valve is mandatory and left to the installer.
3. The installation of the fixture's expansion tank is mandatory and is to be completed by the installer. The indicated volumes are for reference purposes only..

## Configuration compatibility table SPHERA EVO 2.0 Tower

INDOOR UNIT	SQKN-YEE 1 TC A SQKN-YEE 1 TC A SQKN-YEE 1 TC B INTEGRATION ELECTRIC HEATER							
	Storage	190L	250L	250L	EH024	EH3	EH6	EH9
<b>OUTDOOR UNIT</b>								
MiSAN-YEE 1 S 2.1	✓	✓	-	✓		✓	✓	✓
MiSAN-YEE 1 S 3.1	✓	✓	-	✓		✓	✓	✓
MiSAN-YEE 1 S 4.1	✓	✓	-	✓		✓	✓	✓
MiSAN-YEE 1 S 5.1	✓	✓	-	✓		✓	✓	✓
MiSAN-YEE 1 S 6.1	-	-	✓		✓	✓	✓	✓
MiSAN-YEE 1 S 7.1	-	-	✓		✓	✓	✓	✓
MiSAN-YEE 1 S 8.1	-	-	✓		✓	✓	✓	✓

## Condensing boiler technical data

MODEL				UC 24.4	UC 33.4	FE 24.4	FE 33.4
<b>Heating capacity</b>							
Nominal heating capacity (Qn)	-	Maximum	[kW]	24,0	34,0	24,5	34,8
		Minimum	[kW]	5,0	5,0	4,8	5,0
Heating capacity (Pn)	60/80°C	Maximum	[kW]	23,4	33,2	24,0	34,0
		Minimum	[kW]	4,8	4,8	4,7	4,9
	30/50°C	Maximum	[kW]	25,2	35,8	26,0	37,0
		Minimum	[kW]	5,3	5,4	5,2	5,4
Performance	60/80°C	Maximum	%	97,7	97,7	97,8	97,7
		Minimum	%	96,5	96,4	97,6	97,2
	30/50°C	Maximum	%	105,1	105,2	106,1	106,2
		Minimum	%	106,9	107,0	107,3	107,1
	30% di Pn	-	%	108,7	108,6	109,7	109,7
Boiler water content	-	-	[l]	2,5	2,8	3,4	4,3
Operating pressure	PMS	Maximum	[bar]	3	3	3	3
	-	Minimum	[bar]	0,5	0,5	0,8	0,8
Expansion tank	Volume	-	[l]	10	10	8	10
	Preload	-	[bar]	1	1	0,8	0,8
<b>ACS performances</b>							
Nominal heating capacity (Qnw)	-	Maximum	[kW]	28,0	34,0	28,5	34,8
		Minimum	[kW]	5,0	5,0	4,7	5,0
Heating capacity	-	Maximum	[kW]	27,3	33,2	28,0	34,0
		Minimum	[kW]	4,8	4,8	4,7	4,8
Specific flow rate	ΔT=25°C	-	[l/min]	16,2	19,2	16,1	19,5
	ΔT=30°C	-	[l/min]	13,5	16,0	13,4	16,2
	ΔT=45 K	-	[l/min]	9,0	10,6	8,9	10,8
	ΔT=40 K	-	[l/min]	10,1	11,9	10,0	12,1
DHW production in continuous operation	ΔT=35 K	-	[l/min]	11,6	13,6	11,5	13,9
	ΔT=30 K	-	[l/min]	13,5	15,8	13,4	16,2
	ΔT=25 K	-	[l/min]	16,2	19,0	16,1	19,5
Water temperature		Maximum	[°C]	60	60	65	65
		Minimum	[°C]	38	38	40	40
Operating pressure	PMW	Maximum	[bar]	6	6	9	9
	-	Minimum	[bar]	0,5	0,5	0,3	0,3
<b>ErP data</b>							
Seasonal efficiency <i>Medium climate</i>	Heating	ηs	%	93	93	94	94
		Energy class	-	A	A	A	A
	DHW	ηwh	%	87	90	85	85
		Energy class	-	A	A	A	A
		DHW profile	-	XL	XL	XL	XXL
Sound power level		Lwa	[dB(A)]	53	56	49	52
<b>Thermal losses and smoke discharge</b>							
Chimney losses	"burner ON 80/60°C"	Pmax	%	2,33	2,27	2,00	2,10
		Pmin	%	2,24	2,32	2,00	2,90
	"burner ON 50/30°C"	Pmax	%	1,70	1,15	1,40	1,40
		Pmin	%	1,37	1,44	1,00	1,00
Smoke temperature	80/60°C	Pmax	[°C]	66,5	64,9	66	67
		Pmin	[°C]	64,3	65,9	64	62
	50/30°C	Pmax	[°C]	53,6	52,7	52	53
		Pmin	[°C]	47,2	48,4	44	45
Smoke flow rate	-	Pmax	[g/s]	13,8	15,6	11,2	16
	-	Pmin	[g/s]	2,3	2,3	2,3	2,4
Nitrogen oxide (NOX) emissions		Class	-	6	6	6	6
			[mg/kWh]	45	49	35	33

# General technical data

## Hydraulic data - Indoor unit + Outdoor unit

SIZE			2.1		3.1		4.1		5.1		6.1		7.1		8.1	
	Characteristics		190 L	250 L	190 L	250 L	190 L	250 L	190 L	250 L	250 L	250 L	250 L	250 L	250 L	250 L
Minimum system water content	1	l	40		40		40		40		40		40		40	
Minimum admitted water flow rate		l/s	0,16		0,16		0,16		0,16		0,16		0,16		0,16	
Maximum admitted water flow rate		l/s	0,61	0,86	0,61	0,86	0,61	0,86	0,61	0,86	0,92	0,92	0,92	0,92	0,92	0,92
Net boiler capacity		l	182	240	182	240	182	240	182	240	240	240	240	240	240	240
DHW tank setpoint		°C	50	50	50	50	50	50	50	50	50	50	50	50	50	50
Water mixed at 40°C (V40)		l	204	269	204	269	204	269	204	269	269	269	269	269	269	269
Warm-up time	2	h:min	02:30	02:25	02:30	02:25	02:08	02:05	02:08	02:05	01:46	01:46	01:46	01:46	01:46	01:46
Energy consumption during heating	3	kWh	2,20	2,70	2,20	2,70	2,30	2,85	2,30	2,85	3,01	3,01	3,01	3,01	3,01	3,01

1. Consider the water content of the area with less volume
2. Time required to bring the water volume of the tank from a temperature of 10°C to a temperature of 50°C
3. Energy consumption to bring the water volume of the tank from a temperature of 10°C to a temperature of 50°C

## Electrical data

### Outdoor unit

SIZE			2.1	3.1	4.1	5.1	6.1	7.1	8.1
<b>Power supply 220-240V ~ 50Hz</b>									
F.L.A. - Full load current at max admissible conditions		A	10.0	11.8	15.0	16.4	24.5	25.9	27.7
F.L.I. - Full load power input at max admissible conditions		kW	2.20	2.60	3.30	3.60	5.40	5.70	6.10
M.I.C. - Maximum inrush current		A	10.0	11.8	16,7	16.4	24.5	25.9	27.7
<b>Power supply 380-415V 3N~ 50Hz</b>									
F.L.A. - Full load current at max admissible conditions		A	-	-	-	-	8.20	8.70	9.30
F.L.I. - Full load power input at max admissible conditions		kW	-	-	-	-	5.40	5.70	6.10
M.I.C. - Maximum inrush current		A	-	-	-	-	8.20	8.70	9.30

### Indoor unit

SIZE			A - 190 L	A - 250 L	B - 250 L
<b>Power supply 220-240V ~ 50Hz</b>					
F.L.A. - Current draw without DHW heating element		A	0,50	0,90	0,90
F.L.A. - Current draw of DHW heating element		A	8,70	8,70	8,70
F.L.A. - TOTAL current draw under maximum conditions		A	9,20	9,60	9,60
F.L.I. - Power draw without DHW heating element		kW	0,10	0,20	0,20
F.L.I. - Power draw of DHW heating element		kW	2,00	2,00	2,00
F.L.I. - Total power draw under full load		kW	2,10	2,20	2,20
M.I.C. - Maximum inrush current of unit		A	9,20	9,60	9,60

Power supply 220-240V ~ 50Hz +/-10%

The units are conforming with the prescriptions of European Standards CEI EN 60335

(\*) All data calculated with zero height difference and a length of 7m.

**⚠ Important:** when rating the unit, check that the absorptions are conforming to the utility contract in the country of installation

## 2 zones external kit

### INDOOR UNIT 220-240V ~ 50HZ

Power supply		220-240V ~ 50Hz
F.L.A. - Full load current at max admissible conditions	A	0,45
F.L.I. - Full load power input at max admissible conditions	kW	0,10

Power supply 220-240V ~ 50Hz +/-10%.

The units are conforming with the prescriptions of European Standards CEI EN 60335.

## Auxiliary condensate collection tray

### INDOOR UNIT 220-240V ~ 50HZ

Power supply		220-240V ~ 50Hz
F.L.A. - Full load current at max admissible conditions	A	0,40
F.L.I. - Full load power input at max admissible conditions	kW	0,08

Power supply 220-240V ~ 50Hz +/-10%.

The units are conforming with the prescriptions of European Standards CEI EN 60335.

## Additional electric heater - EH024/EH3/EH6/EH9

SIZE		2 kW	3 kW	4 kW
<b>Power supply 220-240V ~50Hz</b>				
F.L.A. - Full load current at max admissible conditions	A	8,70	13,1	17,4
F.L.I. - Full load power input at max admissible conditions	kW	2,00	3,00	4,00

Power supply 220-240V ~50Hz +/- 10%

Size 2kW and 4kW available only for indoor unit A, size 3kW available only for indoor unit B

SIZE		6 kW	9 kW
<b>Power supply 380-415V 3N ~50Hz</b>			
F.L.A. - Full load current at max admissible conditions	A	8,60	13,0
F.L.I. - Full load power input at max admissible conditions	kW	6,00	9,00

Power supply 380-415V 3N ~50Hz +/- 6%.

Data to be added to the values of the standard unit without DHW electric heater.

**!** The additional electric heater is not an accessory supplied separately, but a construction configuration.

## Electrical data of the hybrid solution condensing boiler

MODEL		UC 24.4	UC 33.4	FE 24.4	FE 33.4
Power supply	[V-Hz]	230/50	230/50	230/50	230/50
F.L.A. - Full load current at max admissible conditions	[A]	0,41	0,53	0,36	0,43
F.L.I. - Full load power input at max admissible conditions	[kW]	0,095	0,122	0,082	0,099
Power supply fuse	-	3,15	3,15	3,15	3,15
Protection rating	IP	X5D	X5D	X4D	X4D

Power supply: +/-10%

The units comply with the requirements of European standards EN 60335-1 and EN 60335-2-40

Data to be added to standard indoor unit values.

# General technical data

## Sound levels outdoor unit

### Standard mode

SIZE	Sound power level								Sound pressure level	Sound power level
	Octave band (Hz)									
	63	125	250	500	1000	2000	4000	8000	dB(A)	dB(A)
<b>2.1</b>	46	49	49	52	52	46	37	27	42	55
<b>3.1</b>	49	48	50	55	53	48	39	30	44	57
<b>4.1</b>	36	51	53	56	55	49	44	30	45	58
<b>5.1</b>	37	56	53	57	57	51	47	36	47	60
<b>6.1</b>	44	53	54	60	58	55	52	51	50	63
<b>7.1</b>	44	54	55	60	59	57	56	54	51	64
<b>8.1</b>	46	58	57	60	61	59	54	51	53	66

Sound levels refer to units with full load under nominal test conditions. Data referred to the following conditions: entering / leaving exchanger water temperature user side 47/55°C source side exchanger air inlet 7°C.  
The sound pressure level refers to a distance of 1m from the external surface of the units operating in an open field.  
Noise levels are determined using the tensiometric method (UNI EN ISO 9614-2).

### Silenced mode

SIZE	Sound pressure level	Sound power level
	dB(A)	dB(A)
<b>2.1</b>	40	53
<b>3.1</b>	40	53
<b>4.1</b>	42	55
<b>5.1</b>	42	55
<b>6.1</b>	46	59
<b>7.1</b>	47	60
<b>8.1</b>	48	61

Sound levels refer to units with full load under nominal test conditions.  
For maximum capacity delivered in silent mode use a correction factor of 0.8.  
Data referred to the following conditions: entering / leaving exchanger water temperature user side 47/55°C source side exchanger air inlet 7°C.  
The sound pressure level refers to a distance of 1m from the external surface of the units operating in an open field.  
Noise levels are determined using the tensiometric method (UNI EN ISO 9614-2).

### Super-silenced mode

SIZE	Sound pressure level	Sound power level
	dB(A)	dB(A)
<b>2.1</b>	37	50
<b>3.1</b>	38	51
<b>4.1</b>	39	52
<b>5.1</b>	39	52
<b>6.1</b>	41	54
<b>7.1</b>	41	54
<b>8.1</b>	41	54

Sound levels refer to units with full load under nominal test conditions.  
For maximum capacity delivered in silent mode use a correction factor of 0,6  
Data referred to the following conditions: entering / leaving exchanger water temperature user side 47/55°C source side exchanger air inlet 7°C.  
The sound pressure level refers to a distance of 1m from the external surface of the units operating in an open field.  
Noise levels are determined using the tensiometric method (UNI EN ISO 9614-2).

## Operating limits

### Cooling

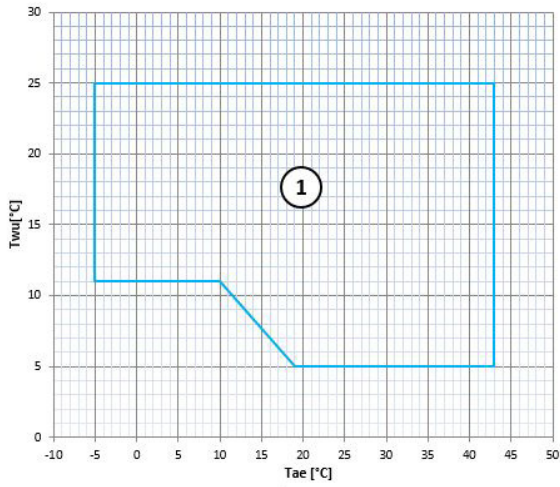

T<sub>wout</sub> [°C] = Exchanger water outlet temperature  
 T<sub>ae</sub> [°C] = Outdoors exchanger air inlet temperature

1. Normal operating range

### Heating

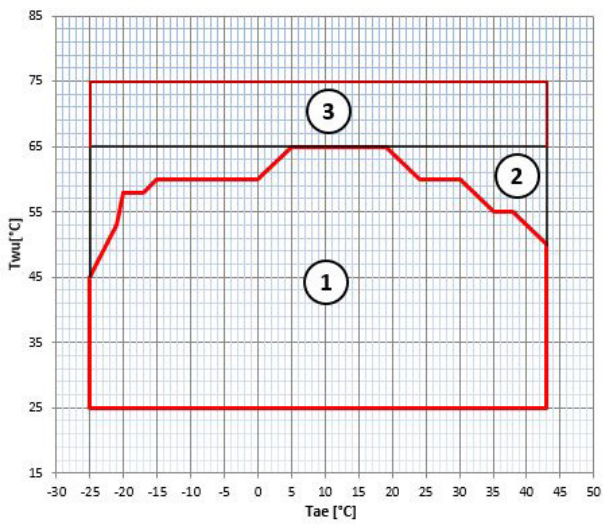

T<sub>wout</sub> [°C] = Exchanger water outlet temperature  
 T<sub>ae</sub> [°C] = Outdoors exchanger air inlet temperature

1. Normal operating range
2. Operating range with additional electric heater option
3. Hybrid system operating range

In the configuration with the integration electric heater, the extension of the limits varies according to the electrical capacity of the electric heater chosen.

# General technical data

## Performance curves in domestic hot water production

Curves referring to the switch-on of the unit from which 90 litres of water were taken out of a total of about 190 available (at an equivalent temperature of 40°C).

### Heating time

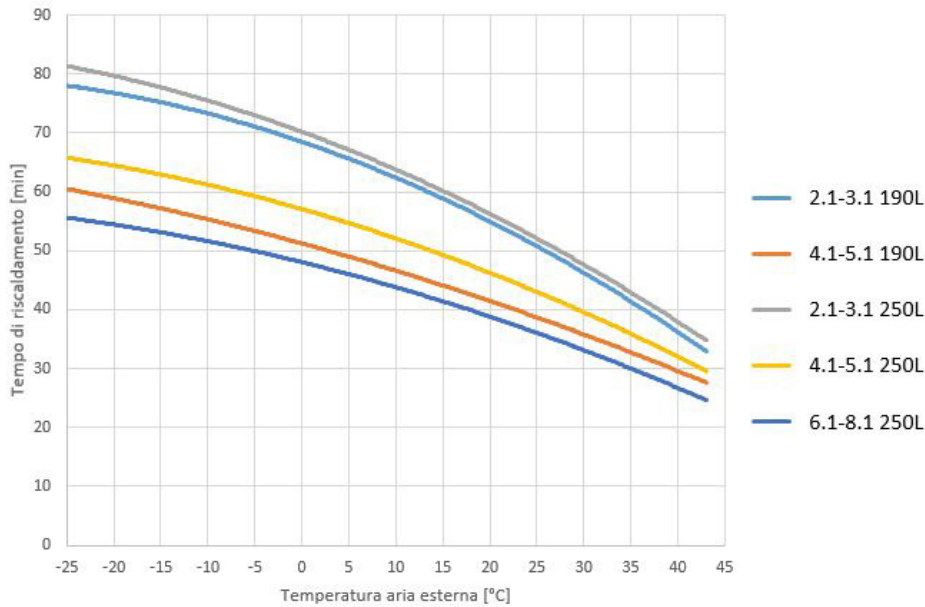

### Energy consumption

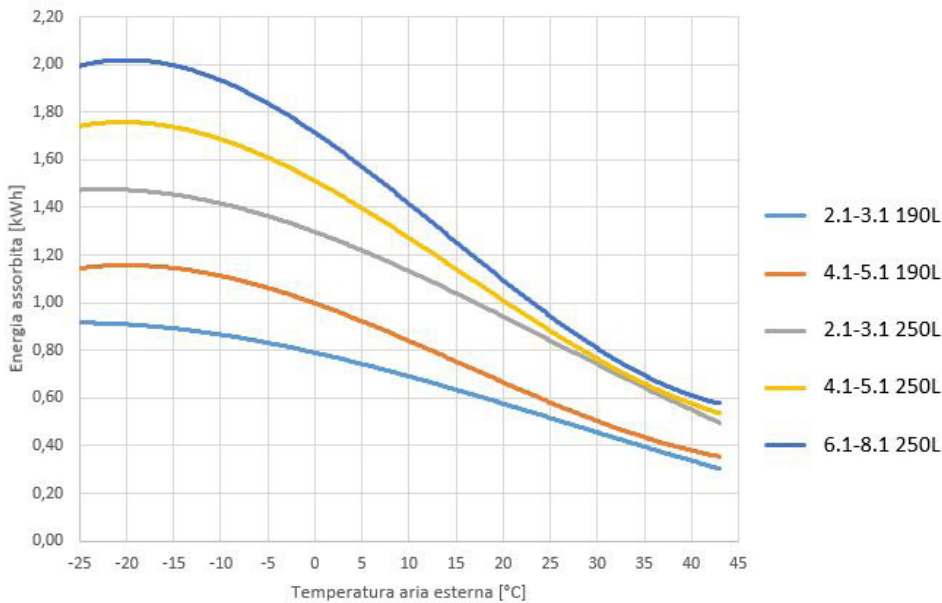

Nominal test conditions:

- Storage temperature (T5) at power-off = 50°C
- Storage temperature (T5) at switch-on = 40°C
- Amount drawn = 3 l/min

## Available pressure of the standard circulator at the unit 190 L A connections

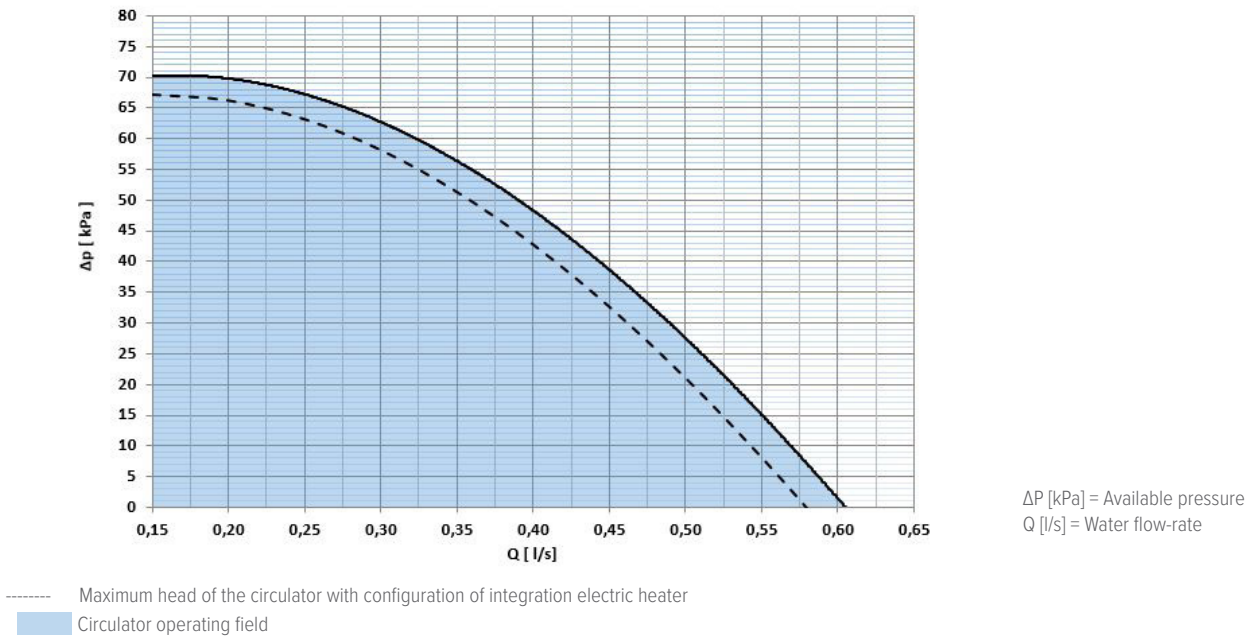

## Absorption of the standard circulator at the unit 190 L - A

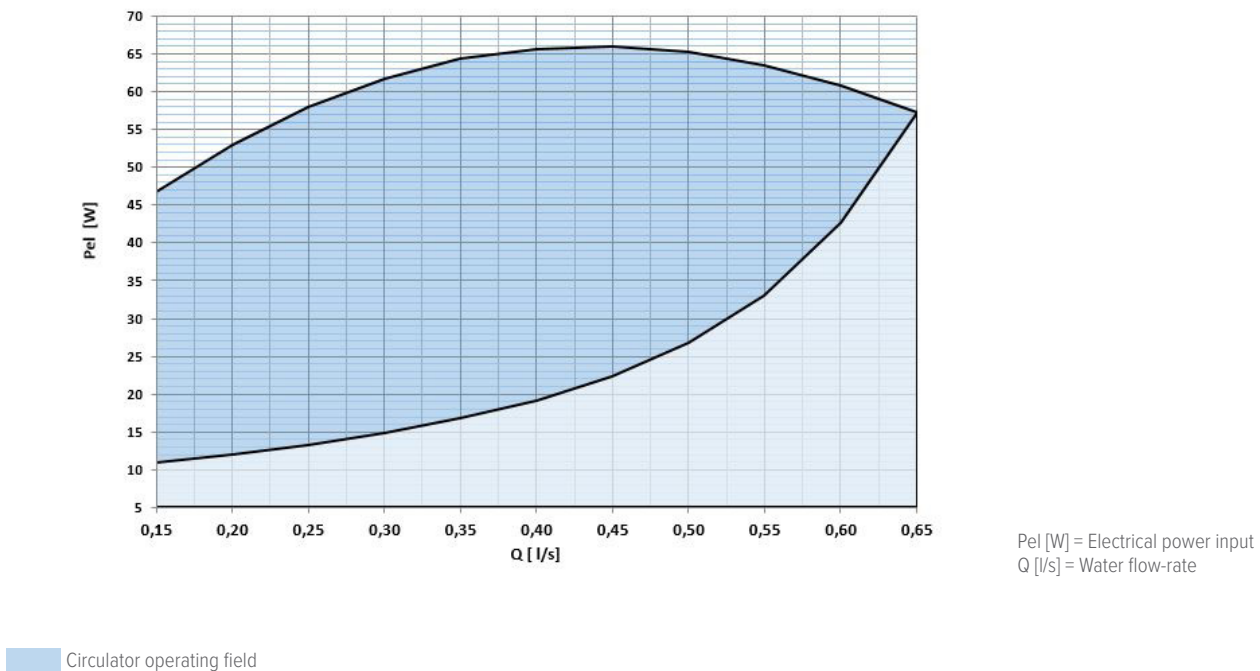



# General technical data

## Available pressure of the standard circulator at the unit 250 L A connections

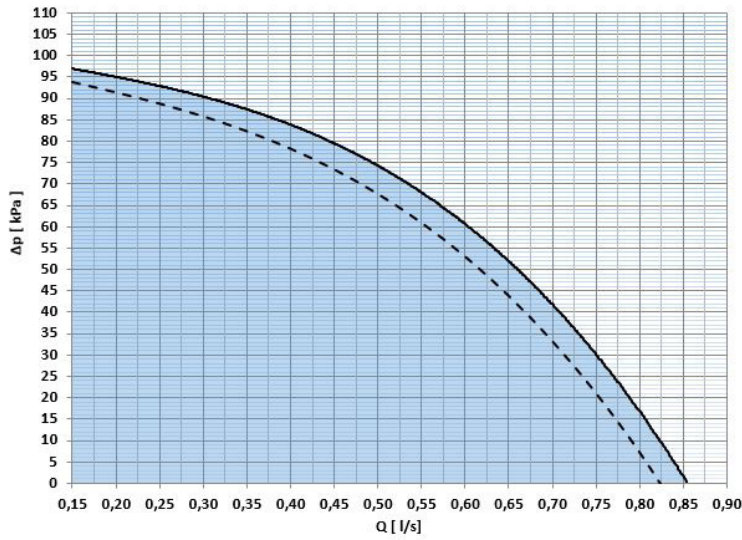

ΔP [kPa] = Available pressure  
Q [l/s] = Water flow-rate

----- Maximum head of the circulator with configuration of integration electric heater

■ Circulator operating field

## Absorption of the standard circulator at the unit 250 L - A

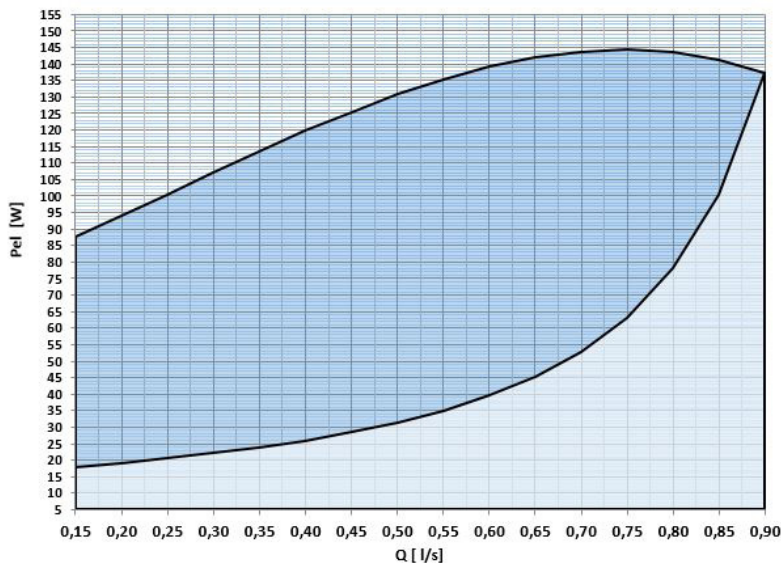

Pel [W] = Electrical power input  
Q [l/s] = Water flow-rate

■ Circulator operating field

## Available pressure of the standard circulator at the unit 250 L B connections

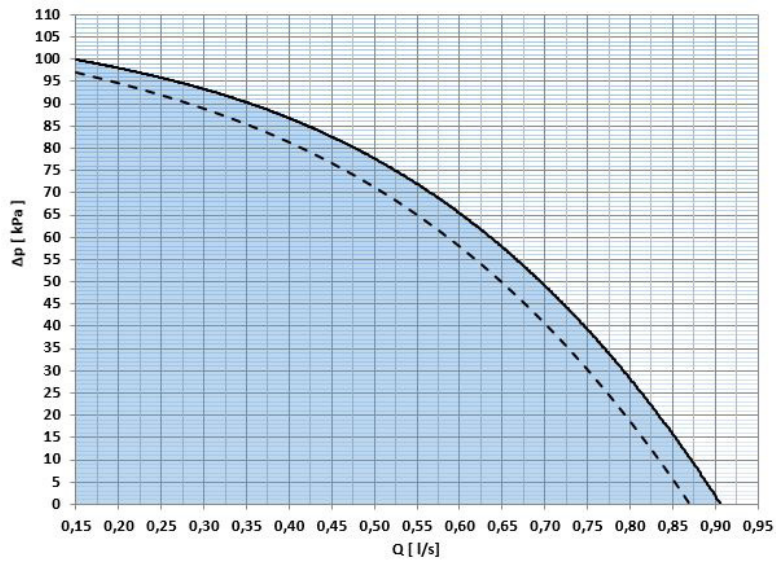

$\Delta P$  [kPa] = Available pressure  
 $Q$  [l/s] = Water flow-rate

----- Maximum head of the circulator with configuration of integration electric heater.  
 ■ Circulator operating field

## Absorption of the standard unit 250 L - B

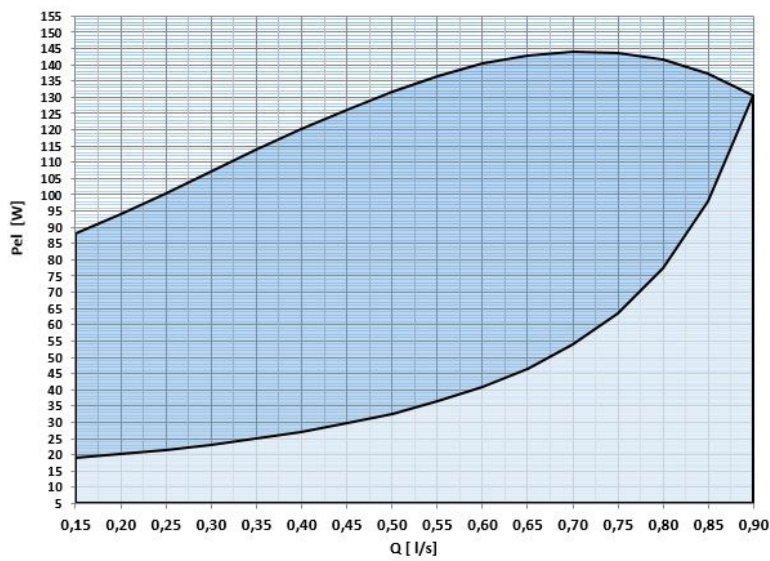

$P_{el}$  [W] = Electrical power input  
 $Q$  [l/s] = Water flow-rate

■ Circulator operating field

# General technical data

## Available pressure for direct booster system circulator

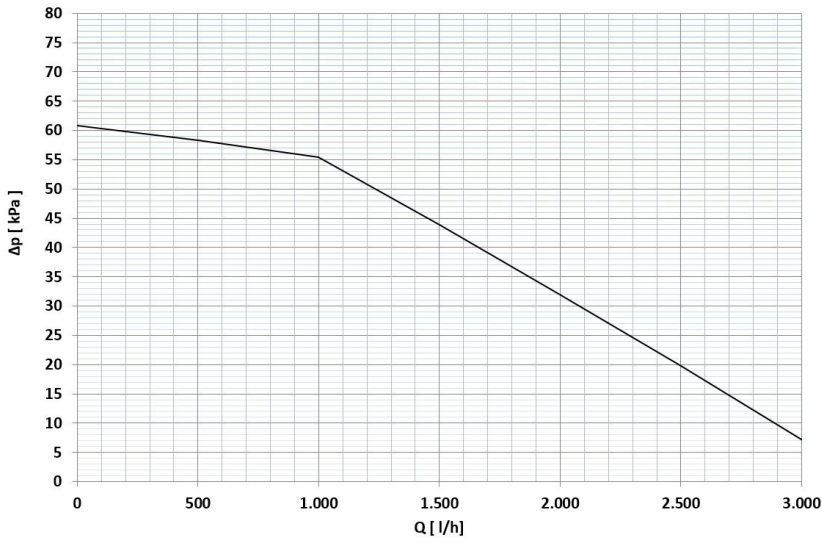

ΔP [kPa] = Available pressure  
Q [l/h] = Water flow-rate

## Available pressure for mixed booster system circulator

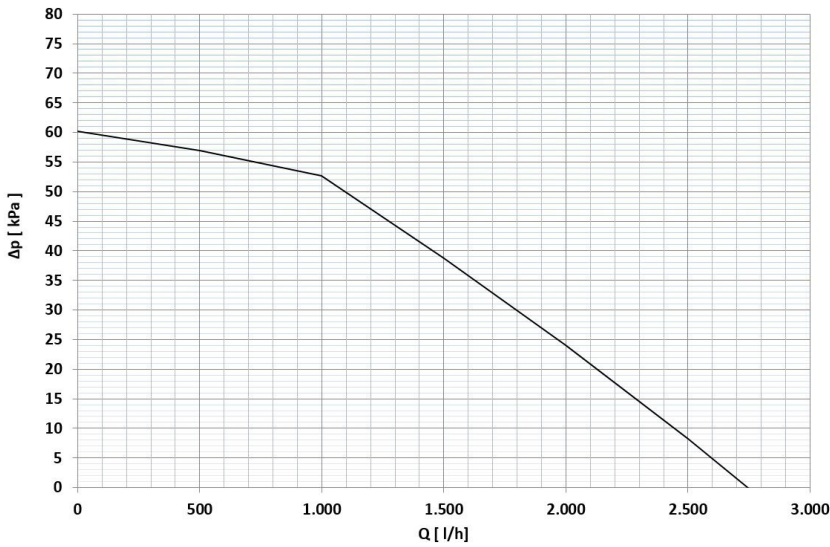

PeI [W] = Electrical power input  
Q [l/h] = Water flow-rate

## Pressure drops - VDACSX accessory

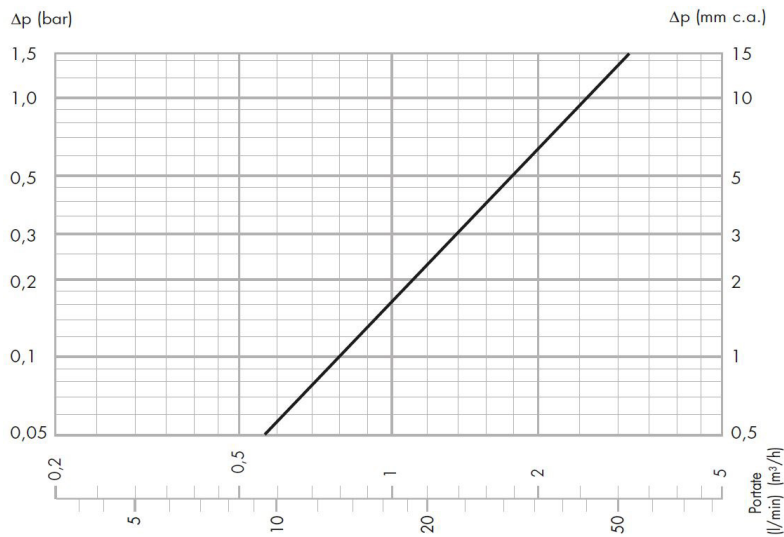

## Available pressure of the circulator - GAS BOILER UC

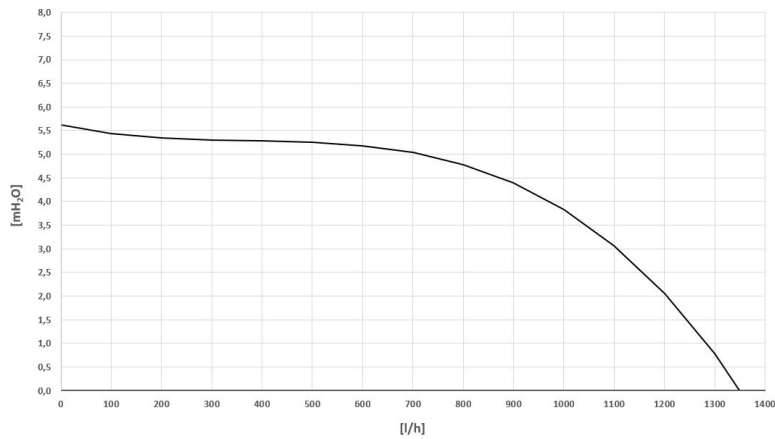

[mH<sub>2</sub>O] = Available pressure  
[l/h] = Water flow-rate

## Available pressure of the circulator - GAS BOILER FE 24.4

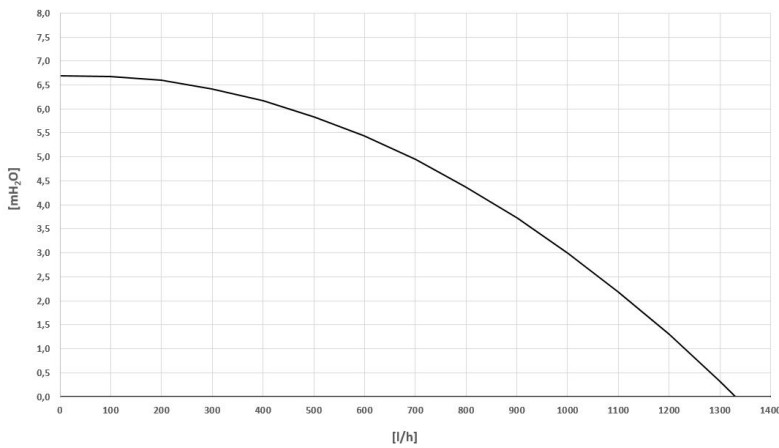

[mH<sub>2</sub>O] = Available pressure  
[l/h] = Water flow-rate

## Available pressure of the circulator - GAS BOILER FE 33.4

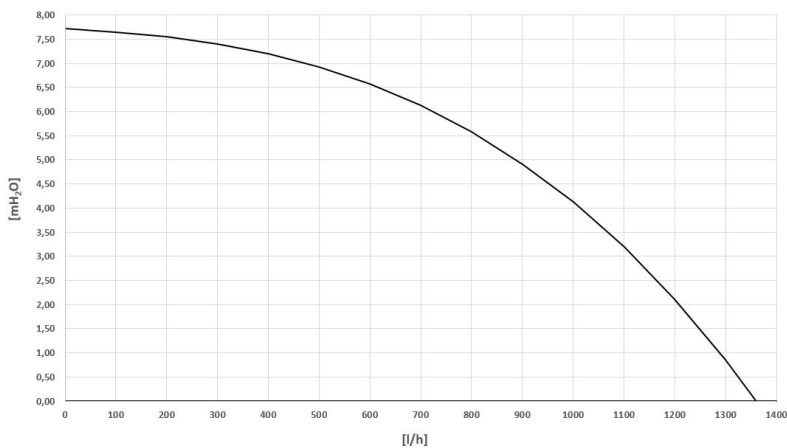

[mH<sub>2</sub>O] = Available pressure  
[l/h] = Water flow-rate

## Sizing the refrigerant pipes

Equivalent length of pipes (metres) = Effective length (metres) +  
Number of bends x K

Consider K= 0.3 m per wide radius elbow bend.  
Consider K= 0.5 m per standard 90° elbow bend.

⚠ to correctly install the refrigerant pipes and charge the refrigerant gas, refer to the SPHERA MANUAL

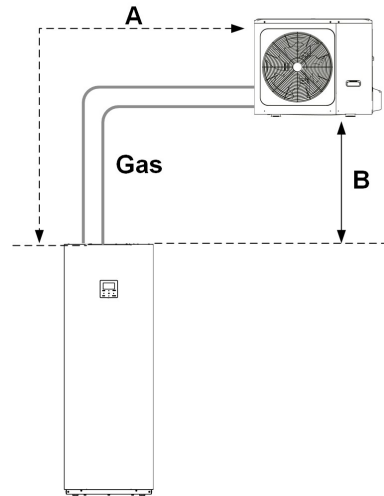

SIZE		2.1	3.1	4.1	5.1	6.1	7.1	8.1
<b>Length and height difference of refrigerant pipes</b>								
A - Refrigerant pipe min/max equivalent length	m	2 - 30	2 - 30	2 - 30	2 - 30	2 - 30	2 - 30	2 - 30
B - Maximum refrigerant pipe height difference with outdoor unit higher than indoors unit	m	25	25	25	25	25	25	25
B - Maximum refrigerant pipe height difference with outdoor unit underthan indoor unit	m	25	25	25	25	25	25	25
<b>Diameters of refrigerant pipes</b>								
Gas pipe diameter	inch	5/8"	5/8"	5/8"	5/8"	5/8"	5/8"	5/8"
Fluid line diameter	inch	1/4"	1/4"	3/8"	3/8"	3/8"	3/8"	3/8"
Additional charge per meter	kg/m	0,020	0,020	0,038	0,038	0,038	0,038	0,038

The refrigerant pre-charge in the outdoor units is sufficient for connection up to 15 m.

## Determination of cooling and heating power loss

The equivalent length of the cooling lines results in a loss of cooling and heating power supplied to the circuit and DHW system. The graph shows the amount of this loss of powergh

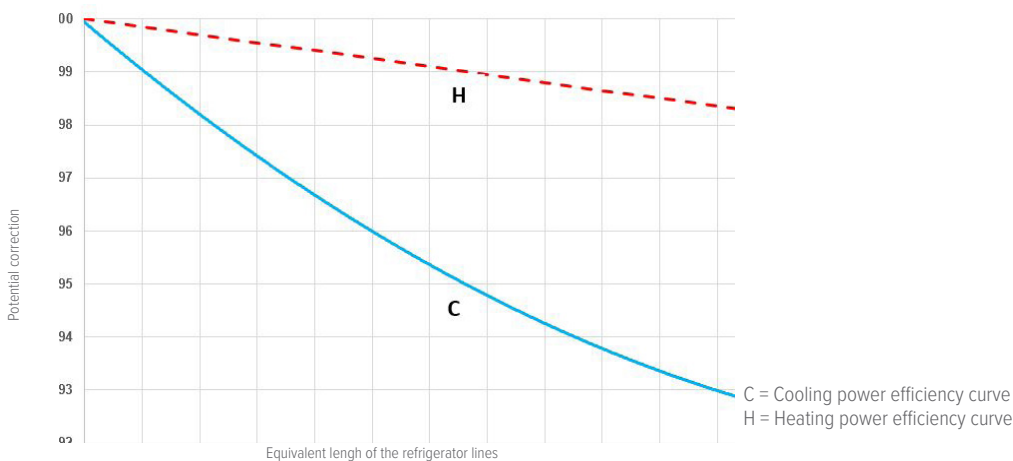

# Water connections

Here are some diagrams of system connections provided as an indication. The connection and design of the system must be carried out in accordance with national regulations in force.

The diagrams do not report the mandatory components to be taken care of by the customer.

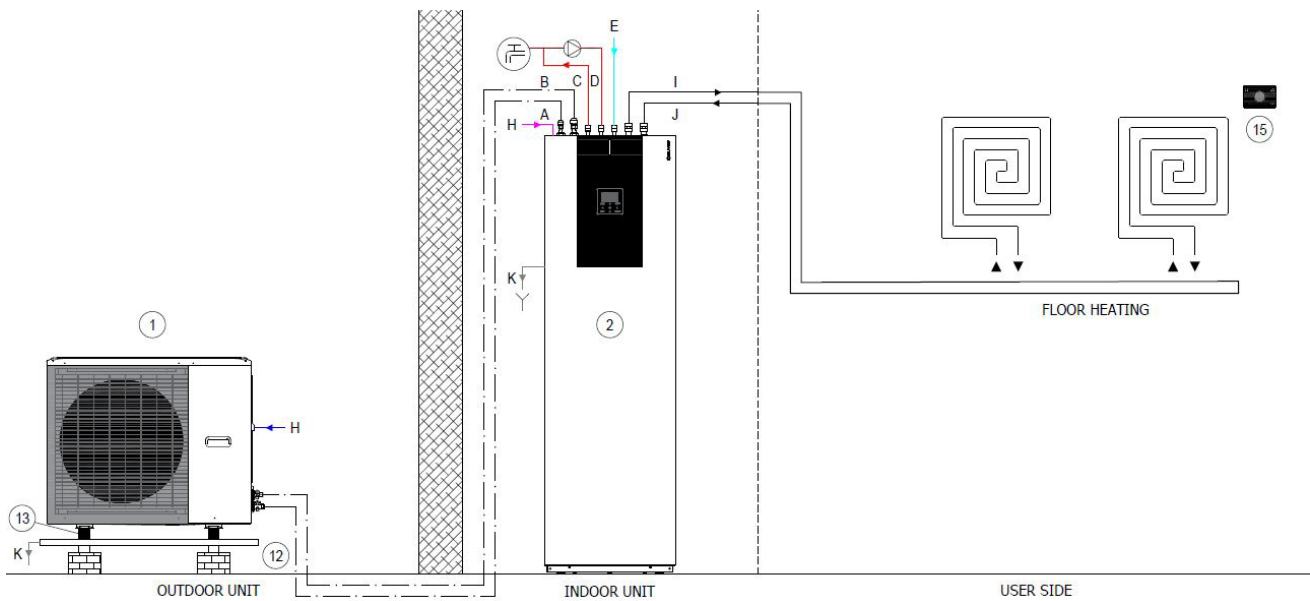

1. Outdoor unit
2. Indoor unit
3. 2 zone kit (KIRE2HX-KIRE2hXL)
4. Single zone kit (KCSX)
5. Integration electric heater (EH024 - EH3 - EH6 - EH9)
6. Drain-back solar integration for domestic hot water (SOLX) --> only Tower
7. Solar panel
8. Hybrid solution (HYSO24 - HYSO34)
9. 40L inertial storage tank (ACI40X)
10. 1-litre circuit breaker (DIX)
11. 50-litre circuit breaker- 60L inertial storage tank (DI50X - ACI60X)
12. Condensate drain pan (DTX)
13. Anti-vibration mount (APAVX - ASTFX)
14. Brackets wall (KSIPX)
15. Chronothermostat (HID-TCXB - HID-TCXN)
16. DHW storage (ACS200X- ACS300X - ACS500X + SCS08X - SCS12X)
17. ElfoControl<sup>3</sup> EVO

- A. Liquid line
- B. Gas line
- C. DHW outlet
- D. DHW recirculation inlet
- E. Aqueduct inlet
- F. Solar outlet
- G. Solar inlet
- H. Power input
- I. System return
- J. System supply
- K. Condensate drain

220-240V~50Hz  
380-415V 3N ~50HZ con EH3 - EH6 - EH9

2.1 - 5.1 single phase 220-240V ~50Hz  
6.1 - 8.1 single phase 220-240V ~50Hz  
6.1 - 8.1 three-phase 380415V 3N~50Hz

..... BUS RS 485  
 \_\_\_\_\_ Technical water  
 \_\_\_\_\_ Domestic cold water  
 \_\_\_\_\_ Domestic hot water  
 \_\_\_\_\_ Condensate drain

# Electrical connections

The electrical hookup must be conforming with the local regulations. The hookup must be done by a specialised technician, qualified to work on live equipment.

SPHERA EVO 2.0 can be controlled with the on-board controller. To operate the unit, you may use: the ELFOControl<sup>3</sup> EVO supervision system or normal electromechanical thermostats.

For more information on connections, consult the installation manual.

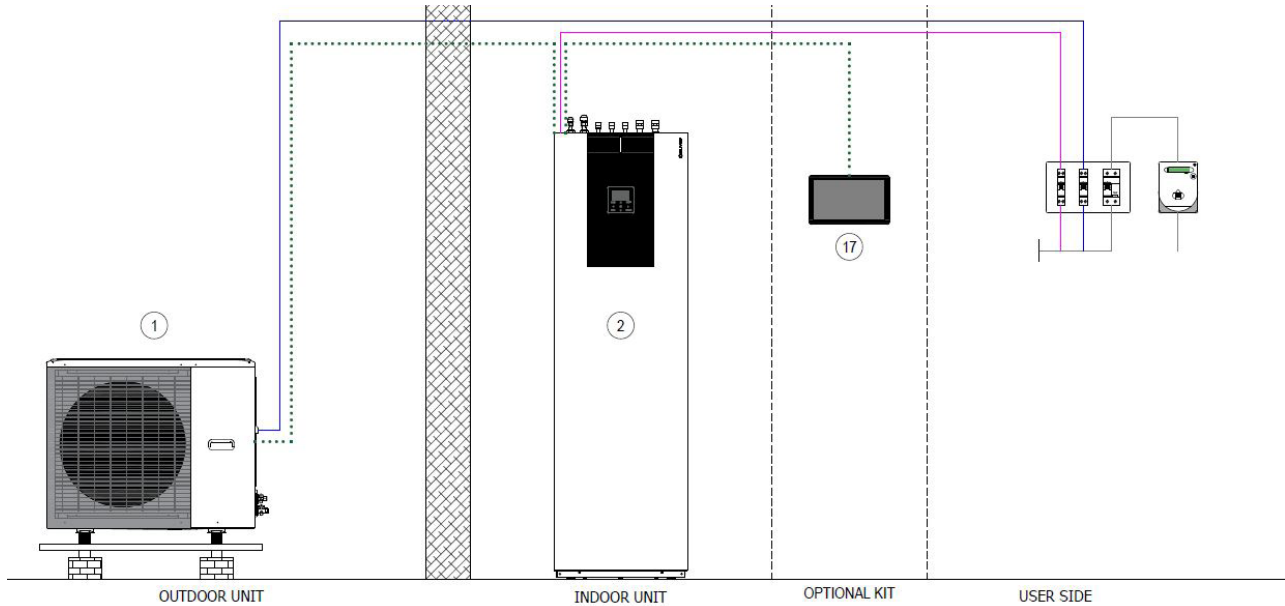

1. Outdoor unit
2. Indoor unit
3. 2 zone kit (KIRE2HX-KIRE2hXL)
4. Single zone kit (KCSX)
5. Integration electric heater (EH024 - EH3 - EH6 - EH9)
6. Drain-back solar integration for domestic hot water (SOLX) --> only Tower
7. Solar panel
8. Hybrid solution (HYSO24 - HYSO34)
9. 40L inertial storage tank (ACI40X)
10. 1-litre circuit breaker (DIX)
11. 50-litre circuit breaker- 60L inertial storage tank (DI50X - ACI60X)
12. Condensate drain pan (DTX)
13. Anti-vibration mount (APAVX - ASTFX)
14. Brackets wall (KSIPX)
15. Chronothermostat (HID-TCXB - HID-TCXN)
16. DHW storage (ACS200X- ACS300X - ACS500X + SCS08X - SCS12X)
17. ElfoControl<sup>3</sup> EVO

- A. Liquid line
- B. Gas line
- C. DHW outlet
- D. DHW recirculation inlet
- E. Aqueduct inlet
- F. Solar outlet
- G. Solar inlet
- H. Power input
- I. System return
- J. System supply
- K. Condensate drain

— 220-240V~50Hz  
380-415V 3N ~50HZ con EH3 - EH6 - EH9

— 2.1 - 5.1 single phase 220-240V ~50Hz  
— 6.1 - 8.1 single phase 220-240V ~50Hz  
— 6.1 - 8.1 three-phase 380415V 3N~50Hz

..... BUS RS 485  
 — Technical water  
 — Domestic cold water  
 — Domestic hot water  
 — Condensate drain

# Auxiliary and hybrid version heat sources

The electrical connection must be carried out in accordance with national regulations in force. The connection must be carried out by specialised personnel who are qualified to work with live voltage. SPHERA EVO 2.0 can be controlled with the built-in control panel. The unit can be called using: the ELFOControl3 EVO supervisory system or common electromechanical thermostats. Refer to the installation manual for more information on the connections.

⚠ Only one of IBH or AHS can be managed

The additional electric heater or boiler can operate as::

- Integration: when it is not convenient/possible to work with the heat pump capacity alone
- Replacement: outside the work settings of the heat pump
- Back-up: in case of unit failure (the unit keeps the pump running at maximum speed)

A third-party supplier's boiler, if any, must be installed in parallel with the heat pump and can act:

- on the system and DHW: installed directly on the system, in this case its operation will require a dedicated T1 temperature probe (to be selected separately) to be installed downstream

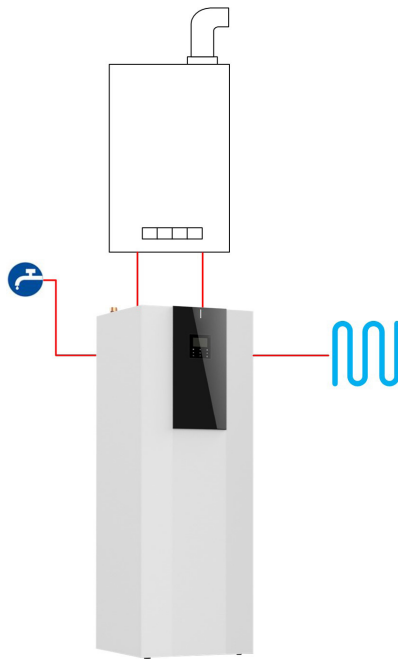

⚠ Requires installation of the KCCEX kit, the T1 probe is included and must be fitted inside the indoor unit downstream of the boiler

- only on the system: installed on a hydraulic separator, where the T1 probe (to be selected separately) must also be fitted

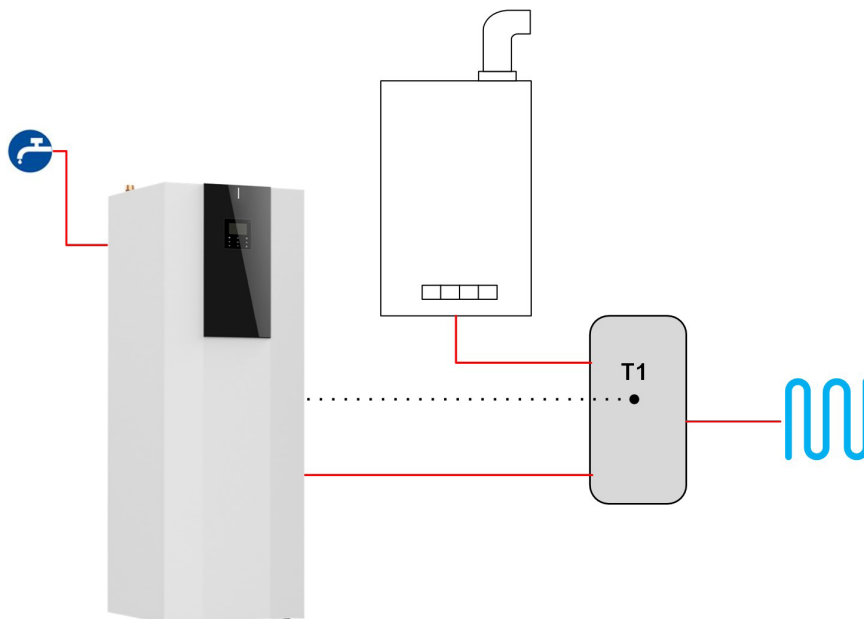



# Auxiliary and hybrid version heat sources

The activation operating mode (in Heating, DHW production or both) must be selected with the dip-switches on the board during installation.

Activation of the auxiliary source is linked to the simultaneous presence of 3 conditions, each of which is associated with a parameter that can be adjusted during initial start-up on the user interface:

- very low outdoor temperature  
parameter  $T4\_IBH\_ON$  or  $T4\_AHS\_ON$  (default  $-5^{\circ}\text{C}$ , adjustable  $-15\div 30$ ): the minimum outdoor air temperature for heat pump operation only

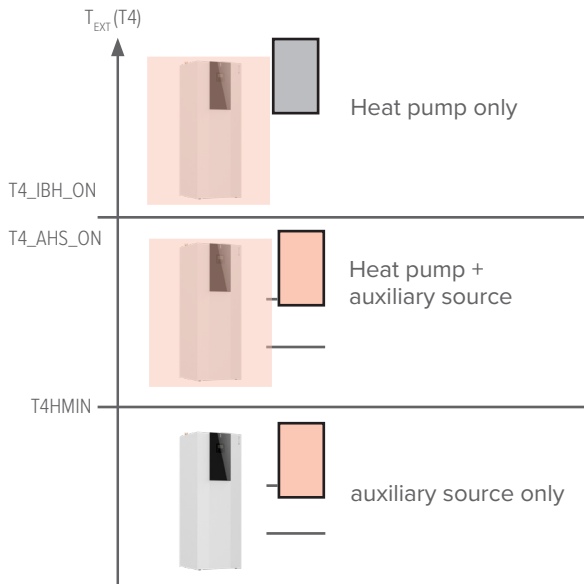

⚠ To make the auxiliary source work only as a replacement for the unit, set the parameter to the same value as  $T4HMIN$  (default  $-15^{\circ}\text{C}$ , adjustable  $-25\div 15$ ): the minimum outdoor air temperature at which the heat pump can operate.

- supply temperature too far from the set-point  
parameter  $dt1\_IBH\_ON$  or  $dt1\_AHS\_ON$  (default  $5^{\circ}\text{C}$ , adjustable  $2\div 10$ ): the minimum  $\Delta T$  between the water set-point  $TS1$  and unit supply set-point  $T1$
- too long to reach the set-point  
parameter  $t\_IBH\_DELAY$  or  $t\_AHS\_DELAY$  (default 30min, adjustable  $5\div 120$ ): the maximum waiting time between compressor start-up and auxiliary source activation

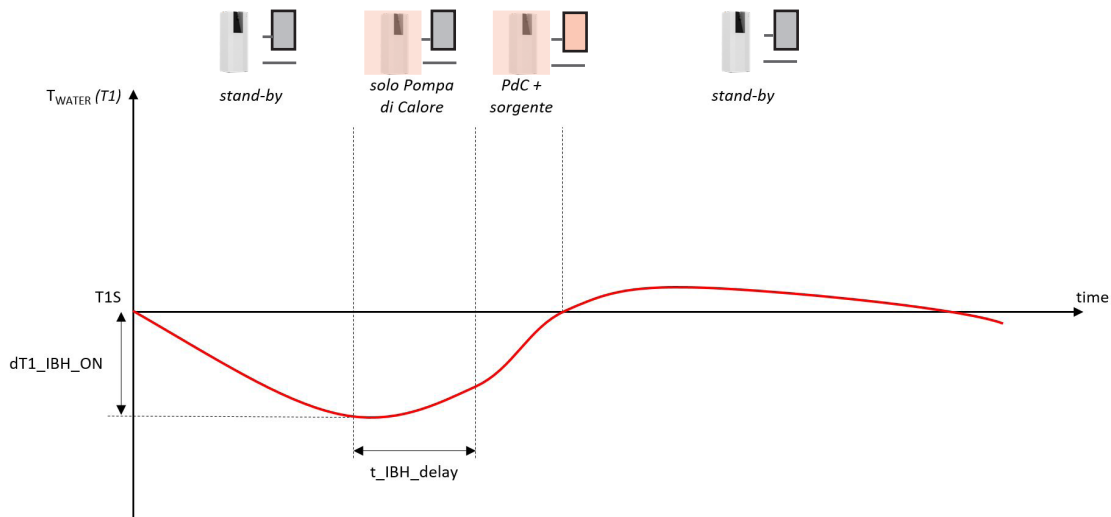

⚠ The BACKUP HEATER function on the HMI allows activation of the IBH or AHS auxiliary source to be forced

The unit can manage the AHS set-point dynamically with a 0-10V signal, with parameters:

- $MAX\_SETHEATER$  (default:  $80^{\circ}\text{C}$ , adjustable) and  $MIN\_SETHEATER$  (default:  $30^{\circ}\text{C}$ , adjustable): the minimum and maximum set-points that can be set in the boiler
- $MAX\_SIGHEATER$  (default: 10V, adjustable) and  $MIN\_SIGHEATER$  (default: 3V, adjustable): the 0-10V signals linked to the minimum and maximum set-points that can be set in the boiler

# Auxiliary and hybrid version heat sources

## Hybrid versions with UC version boiler

The hybrid heat pumps are equipped with a 4-pipe boiler for DHW production and Heating.

The UC GAS BOILER is made as follows:

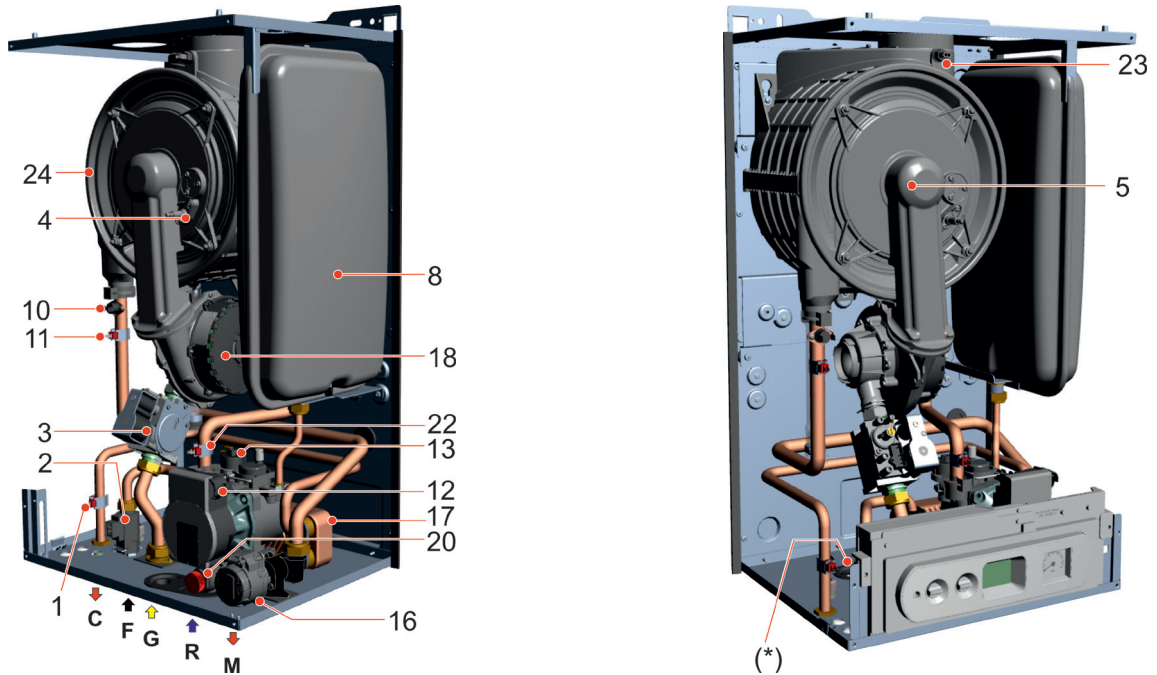

#	NAME	DESCRIPTION
1	SS	DHW water temperature sensor
2	FLS	Flow switch with cold water filter
3	VG	Gas valve
4	E.ACC/RIL	Switch-on Electrode/ detection
5	-	Burner
8	-	Expansion tank
10	TL	Safety thermostat
11	SR	Water temperature sensor - Heating supply
12	P	Circulator
13	DK	Low water control pressure switch
16	-	Switching valve
17	-	DHW plate exchanger
18	VM	Fan
20	-	Pressure relief valve
22	SRR	Water temperature sensor - return
23	TLC	Smoke manifold safety thermostat
24	-	Steel exchanger/condenser
(*)	-	Condensate drain trap outlet position
C	-	DHW output (G 1/2")
G	-	Gas inlet (G 3/4")
F	-	Water inlet for DHW (G 1/2")
M	-	System supply (G 3/4")
R	-	System return (G 3/4")

# Auxiliary and hybrid version heat sources

## Versioni ibride con caldaia in versione FE

FE GAS BOILER is a boiler designed to operate on Natural Gas (G20), Liquid Gas (G30-G31), Propane Air (G230) and it can also regulate itself to operate with natural gas and hydrogen mixtures (80%/20%).

The FE GAS BOILER is made as follows:

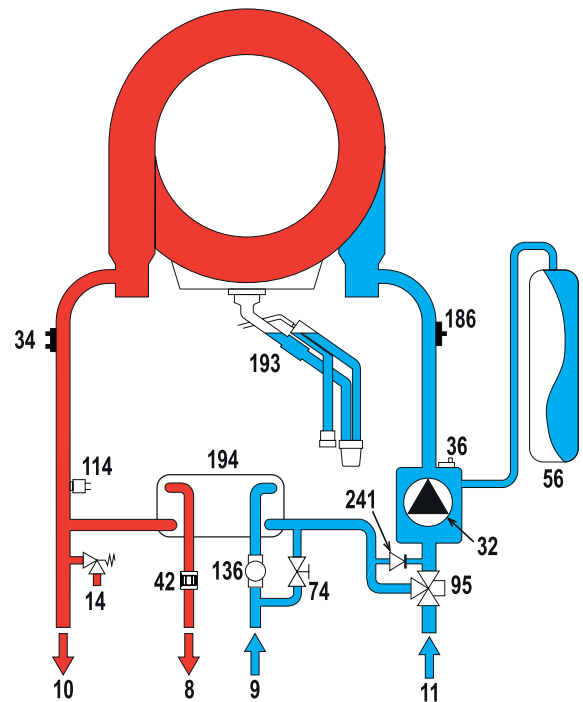
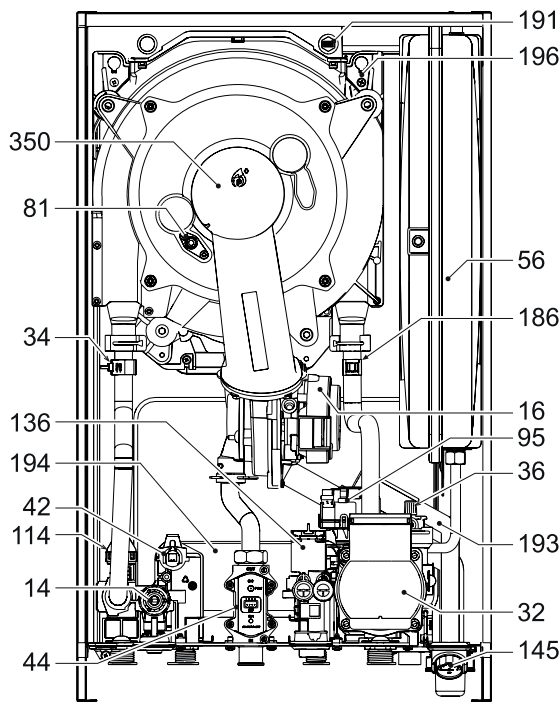

#	DESCRIPTION
8	DHW outlet (G 1/2")
9	DHW water inlet (G 1/2")
10	System supply (G 3/4")
11	System return (G 3/4")
14	Pressure relief valve
16	Fan
32	Circulator
34	Water temperature sensor - Heating supply
36	Automatic air vent
42	DHW water temperature sensor
44	Gas valve
56	Expansion tank
74	System filling shut-off valve
81	Switch-on Electrode/ detection
95	Switching valve
114	Water pressure switch
136	Flowmeter
145	Hydrometer
186	Water temperature sensor - return
191	Smoke temperature sensor
193	Sifone
194	Plate heat exchanger for DHW
196	Drain pan
241	Automatic bypass (inside the pump group)
350	Burner group/fan

## General description of the system and possible connections

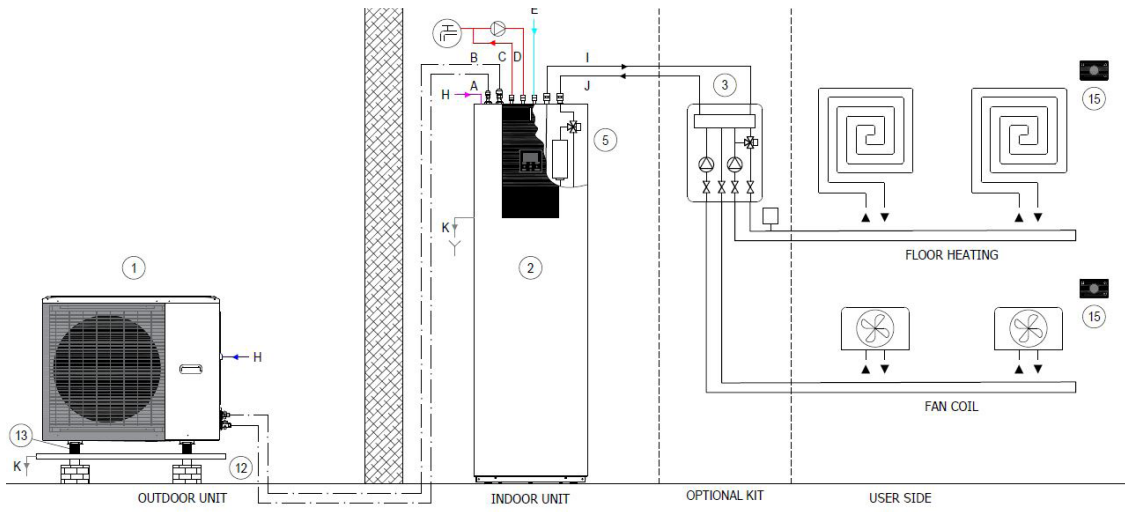

### Additional electric heater

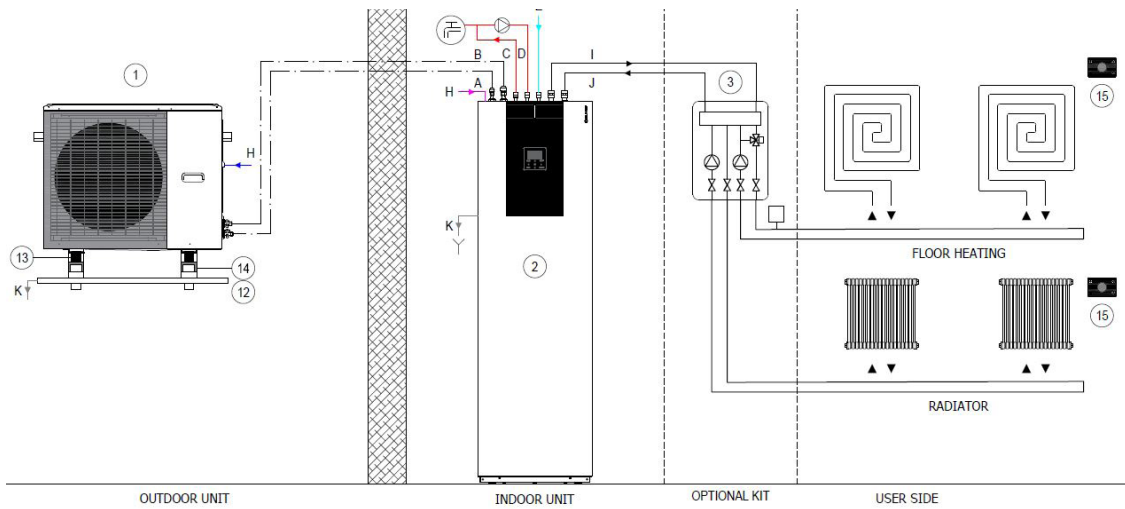

### 2 zone kit

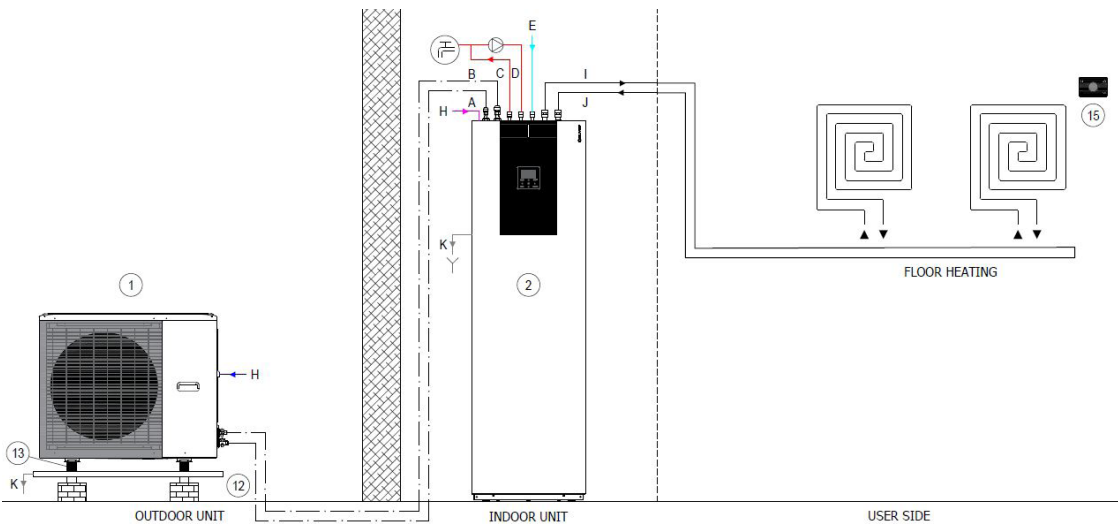

### Single zone

# System connections

## General description of the system and possible connections

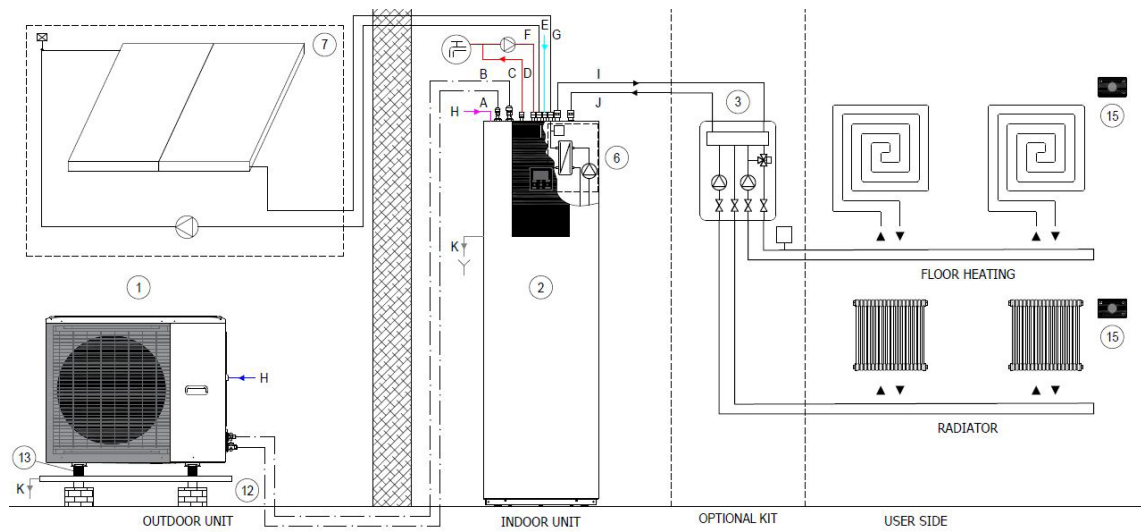

**Solar kit**

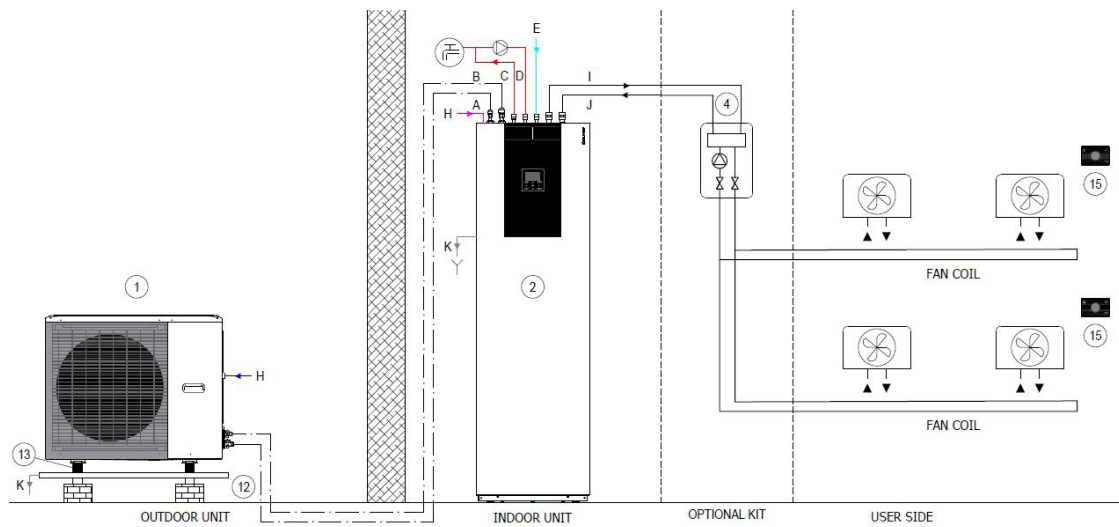

**Single zone kit**

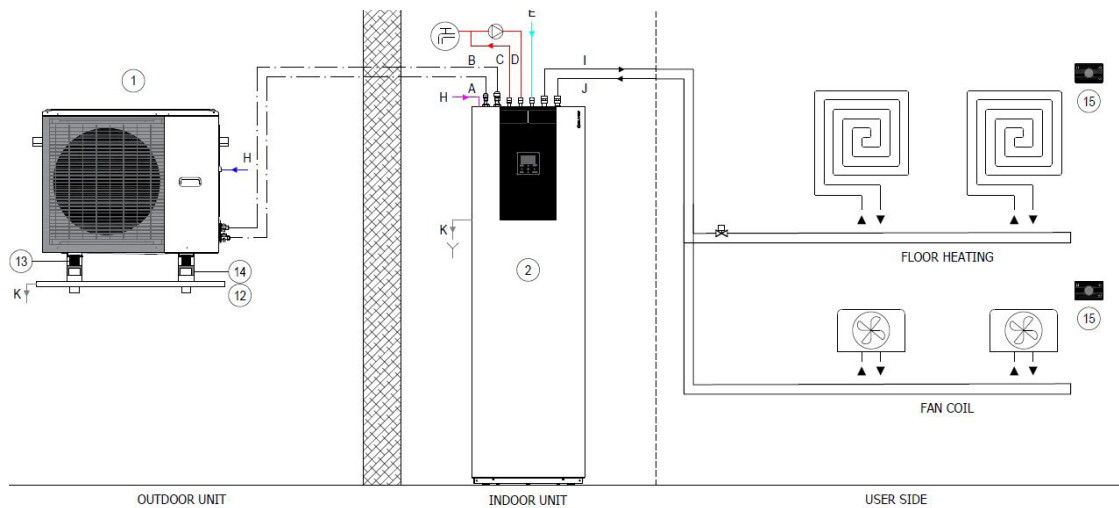

**Single zone V2** by the customer) Shut-off valve to exclude the radiant floors in summer mode.

## General description of the system and possible connections

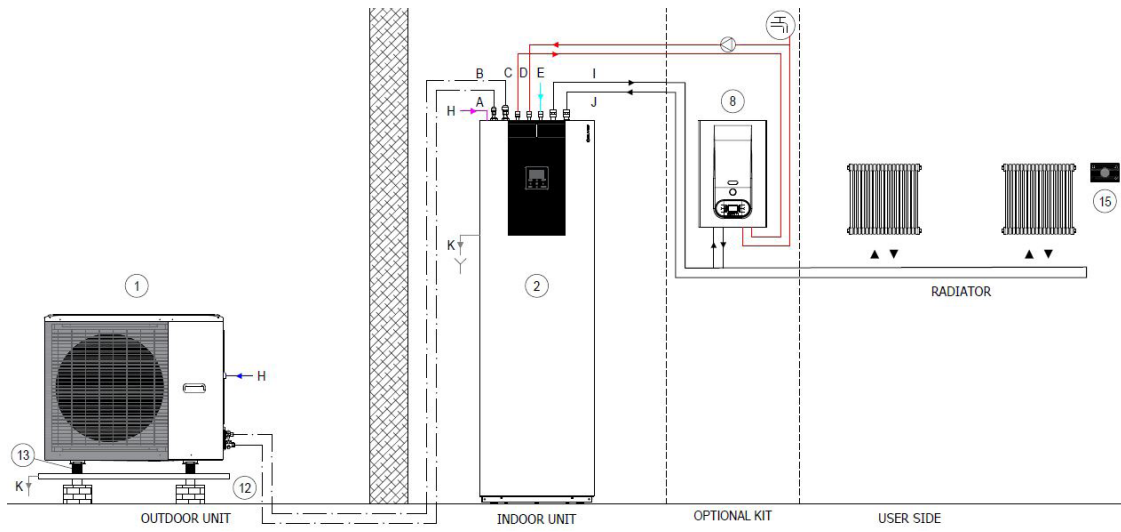

Hybrid solution

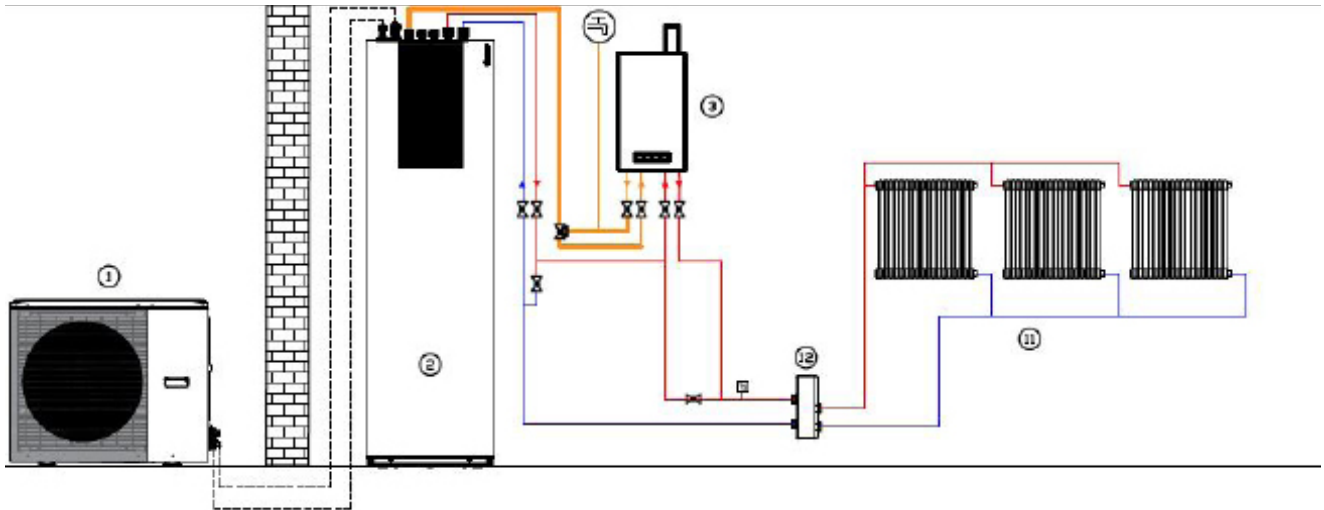

Hybrid solution "Factory made"

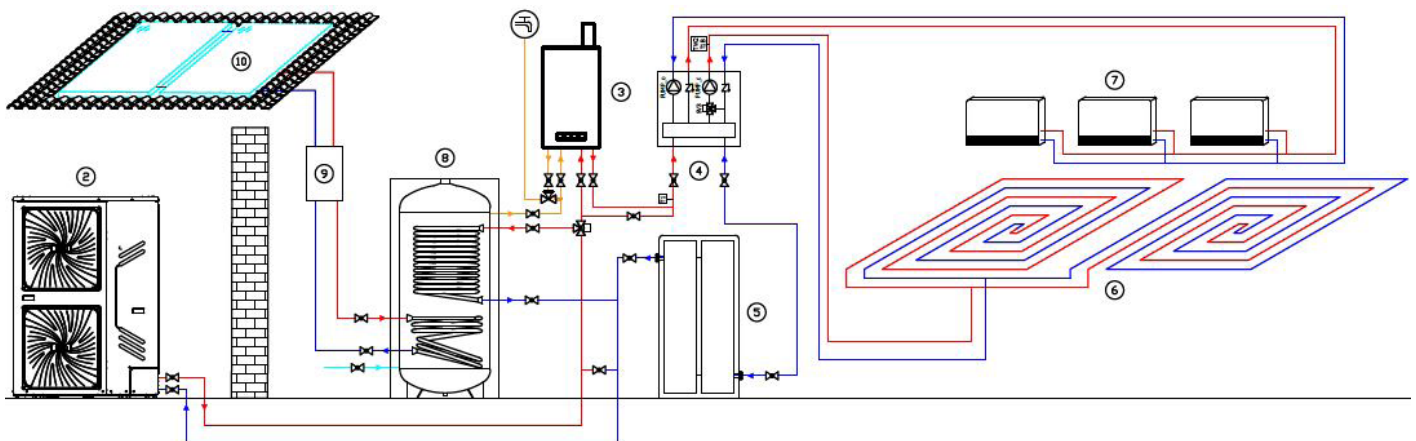

Hybrid solution "Factory made" with DHW storage tank ACS

# System connections

## General description of the system and possible connections

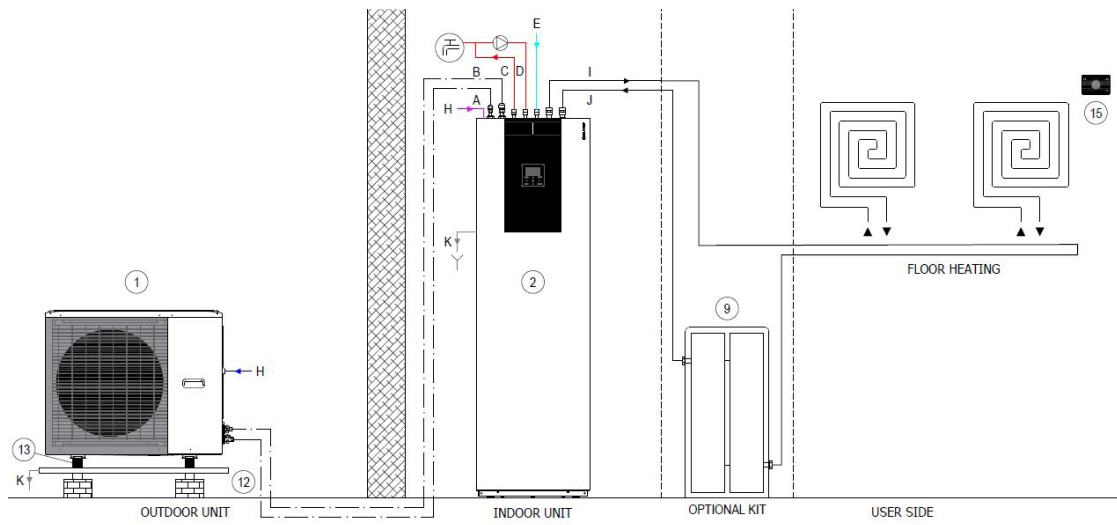

40 or 60 L inertial storage

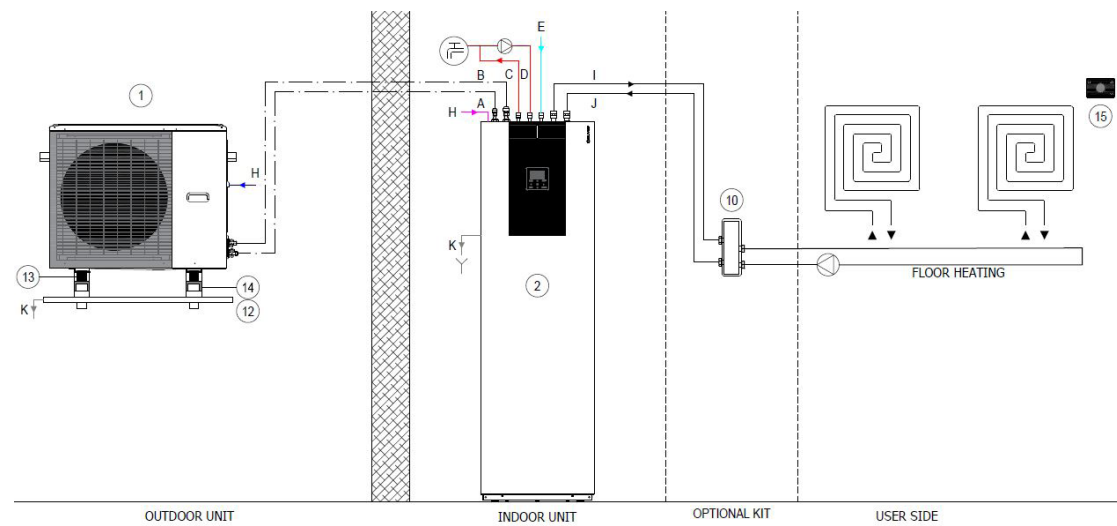

1 L circuit breaker

## General description of the system and possible connections

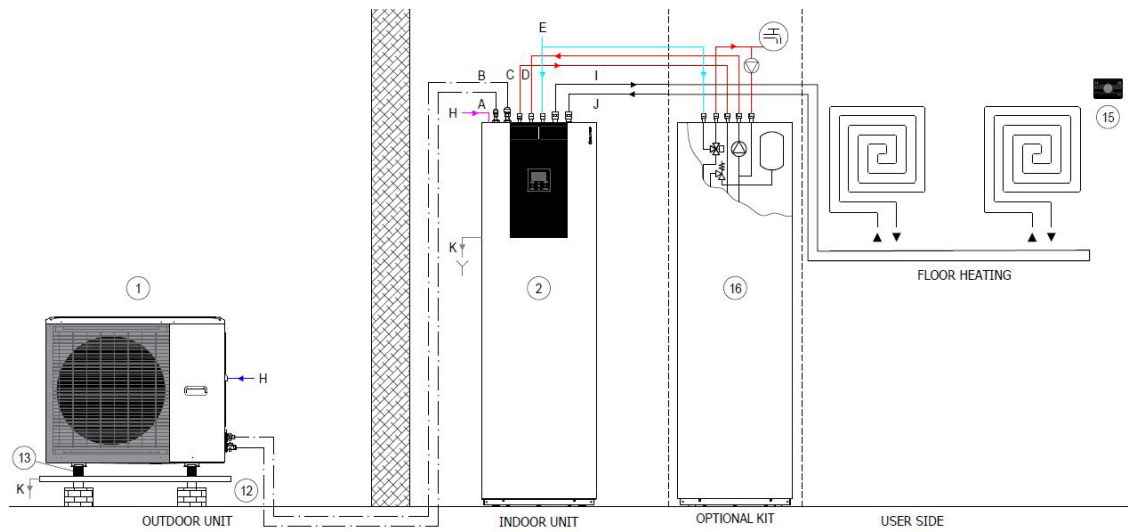

Additional 250 L storage tank

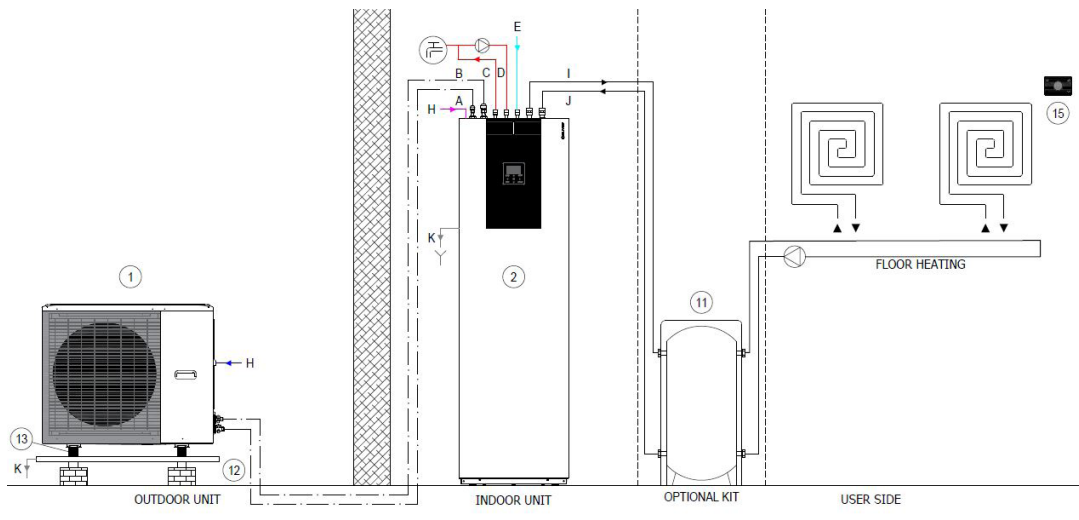

50L circuit breaker - 60L inertial storage tank

1. Outdoor unit
2. Indoor unit
3. 2 zone kit (KIRE2HX-KIRE2hXL)
4. Single zone kit (KCSX)
5. Integration electric heater (EH024 - EH3 - EH6 - EH9)
6. Integrazione solare per sanitario (SOLX) --> solo nel tower
7. Solar panel
8. Hybrid solution (HYSO24 - HYSO34)
9. 40L inertial storage tank (ACI40X)
10. 1-litre circuit breaker (DIX)
11. 50-litre circuit breaker- 60L inertial storage tank (DI50X - ACI60X)
12. Condensate drain pan (DTX)
13. Anti-vibration mount (APAVX - ASTFX)
14. Brackets wall (KSIPX)
15. Chronothermostat (HID-TCXB - HID-TCXN)
16. DHW storage (ACS200X- ACS300X - ACS500X + SCS08X - SCS12X)
17. ElfoControl<sup>3</sup> EVO

- A. Liquid line
- B. Gas line
- C. DHW outlet
- D. DHW recirculation inlet
- E. Aqueduct inlet
- F. Solar outlet
- G. Solar inlet
- H. Power input
- I. System return
- J. System supply
- K. Condensate drain

220-240V~50Hz  
380-415V 3N ~50HZ con EH3 - EH6 - EH9

2.1 - 5.1 single phase 220-240V ~50Hz  
6.1 - 8.1 single phase 220-240V ~50Hz  
6.1 - 8.1 three-phase 380415V 3N~50Hz

- ..... BUS RS 485
- Technical water
- Domestic cold water
- Domestic hot water
- Condensate drain



# Data for the UNI/TS 11300 calculation

Clivet S.p.A. declares that the data to be used for the calculation pursuant to UNI/TS 11300 part 4 of the efficiency of their heat pump are given in the following tables.

The data given in this document may be updated without advance notice by the manufacturer when upgrading his product range..

## UNI/TS 11300 Part 4

### SPHERA EVO 2.0 - Size 2.1

Data for determination of COPPL T delivery 20°C		Tdesignh	A	B	C	D
2.1	Te	-10	-7	2	7	12
	PLR	100%	88%	54%	35%	15%
	DC		4,74	4,50	4,32	4,33
	CR		1,00	0,65	0,44	0,19
	P	5,39	4,74	3,05	1,99	1,45
	COP (part load)		3,15	4,96	6,81	6,23
	COP (full load)		3,15	4,46	5,42	6,37
	Fcop		1,00	1,11	1,26	0,98
Data to be provided for power and COP under full load cold source air						
2.1	Te	Tm	-7	2	7	12
	Heating capacity $\Phi_{H,HP}$ out (kW)	35°C	4,74	4,50	4,32	4,33
		45°C	4,31	4,35	4,16	4,16
		55°C	4,40	4,40	4,08	4,50
	COP	35°C	3,15	4,46	5,42	6,37
		45°C	2,51	3,27	3,93	4,52
55°C		1,99	2,56	3,00	3,44	
DHW Power and COP data under full load			Te			
2.1	Te	Tm	7	15	20	35
	Heating capacity $\Phi_{H,HP}$ out (kW)	55°C	4,08	5,11	5,71	6,85
	COP	55°C	3,00	3,84	4,23	3,90

### SPHERA EVO 2.0 - Size 3.1

Data for determination of COPPL T delivery 20°C		Tdesignh	A	B	C	D
3.1	Te	-10	-7	2	7	12
	PLR	100%	88%	54%	35%	15%
	DC		5,51	5,89	6,18	6,28
	CR		1,00	0,57	0,35	0,15
	P	6,26	5,51	3,30	2,24	1,45
	COP (part load)		3,13	4,91	7,11	5,70
	COP (full load)		3,13	4,15	5,21	6,10
	Fcop		1,00	1,18	1,36	0,93
Data to be provided for power and COP under full load cold source air						
3.1	Te	Tm	-7	2	7	12
	Heating capacity $\Phi_{H,HP}$ out (kW)	35°C	5,51	5,89	6,18	6,28
		45°C	5,22	6,42	6,03	6,53
		55°C	5,15	5,46	5,94	6,64
	COP	35°C	3,13	4,15	5,21	6,10
		45°C	2,41	3,07	3,83	4,41
55°C		2,03	2,56	3,07	3,55	
DHW Power and COP data under full load			Te			
3.1	Te	Tm	7	15	20	35
	Heating capacity $\Phi_{H,HP}$ out (kW)	55°C	5,94	6,99	7,33	8,80
	COP	55°C	3,07	3,97	4,44	4,10

# Data for the UNI/TS 11300 calculation

## SPHERA EVO 2.0 - Size 4.1

Data for determination of COPPL T delivery 20°C		Tdesignh	A	B	C	D
4.1	Te	-10	-7	2	7	12
	PLR	100%	88%	54%	35%	15%
	DC		7,15	5,64	8,30	8,21
	CR		1,00	0,78	0,34	0,15
	P	8,13	7,15	4,65	2,91	1,85
	COP (part load)		3,30	5,17	7,08	6,01
	COP (full load)		3,30	3,69	5,31	6,41
	Fcop		1,00	1,40	1,33	0,94
Data to be provided for power and COP under full load cold source air		Te				
4.1	Te	Tm	-7	2	7	12
	Heating capacity $\Phi_{H,HP}$ out (kW)	35°C	7,15	5,64	8,30	8,21
		45°C	6,34	6,59	8,22	8,07
		55°C	6,08	6,27	7,50	7,55
	COP	35°C	3,30	3,69	5,31	6,41
		45°C	2,56	3,26	3,95	4,69
		55°C	2,17	2,69	3,19	3,72
DHW Power and COP data under full load		Te				
4.1	Te	Tm	7	15	20	35
	Heating capacity $\Phi_{H,HP}$ out (kW)	55°C	7,50	8,37	9,18	11,02
	COP	55°C	3,19	4,11	4,50	4,15

## SPHERA EVO 2.0 - Size 5.1

Data for determination of COPPL T delivery 20°C		Tdesignh	A	B	C	D
5.1	Te	-10	-7	2	7	12
	PLR	100%	88%	54%	35%	15%
	DC		8,45	9,30	10,09	10,26
	CR		1,00	0,56	0,33	0,14
	P	9,60	8,45	5,23	3,47	1,96
	COP (part load)		3,18	5,03	7,33	6,16
	COP (full load)		3,18	4,12	5,01	5,97
	Fcop		1,00	1,22	1,46	1,03
Data to be provided for power and COP under full load cold source air		Te				
5.1	Te	Tm	-7	2	7	12
	Heating capacity $\Phi_{H,HP}$ out (kW)	35°C	8,45	9,30	10,09	10,26
		45°C	7,71	9,16	10,01	10,06
		55°C	7,08	8,49	9,60	9,19
	COP	35°C	3,18	4,12	5,01	5,97
		45°C	2,59	3,11	3,86	4,32
		55°C	2,11	2,66	3,10	3,65
DHW Power and COP data under full load		Te				
5.1	Te	Tm	7	15	20	35
	Heating capacity $\Phi_{H,HP}$ out (kW)	55°C	9,60	8,99	8,78	10,54
	COP	55°C	3,10	4,03	4,53	4,18

Terms and definitions

Tm = Delivery temperature

Tdesignh = A - Average design climate temperature (pursuant to UNI EN 14825)

A, B, C, D = names of the four conditions with which different outdoors air temperatures are associated (Te)

Te = Outdoors air temperature

PLR = part load ratio

DC = power under full load referred to the specified temperatures

CR = heat pump load factor

P = system power demand

COP' (full load) = COP under full load referred to the indicated outdoors air temperatures

COP' (partial load) = COP under partial load referred to the indicated outdoors air temperatures

fCOP = COP correction factor, as follows: COP' (full load) / COP (partial load)HP= heat pump

DHW = domestic hot water

# Data for the UNI/TS 11300 calculation

## SPHERA EVO 2.0 - Size 6.1

Data for determination of COPPL T delivery 20°C		Tdesignh	A	B	C	D
6.1	Te	-10	-7	2	7	12
	PLR	100%	88%	54%	35%	15%
	DC		10,69	13,01	12,13	12,26
	CR		1,00	0,50	0,35	0,15
	P	12,14	10,69	6,57	4,48	3,67
	COP (part load)		3,07	4,68	6,90	6,33
	COP (full load)		3,07	3,93	5,00	5,68
	Fcop		1,00	1,19	1,38	1,12
Data to be provided for power and COP under full load cold source air		Te				
6.1	Te	Tm	-7	2	7	12
	Heating capacity ΦH,HP out (kW)	35°C	10,69	13,01	12,13	12,26
		45°C	11,21	12,52	12,30	11,56
		55°C	10,10	12,05	12,07	10,89
	COP	35°C	3,07	3,93	5,00	5,68
		45°C	3,14	3,34	3,80	4,59
		55°C	1,76	2,88	3,10	3,78
DHW Power and COP data under full load		Te				
6.1	Te	Tm	7	15	20	35
	Heating capacity ΦH,HP out (kW)	55°C	12,07	12,30	13,71	16,45
	COP	55°C	3,10	4,19	4,59	4,23

## SPHERA EVO 2.0 - Size 7.1

Data for determination of COPPL T delivery 20°C		Tdesignh	A	B	C	D
7.1	Te	-10	-7	2	7	12
	PLR	100%	88%	54%	35%	15%
	DC		12,33	12,71	14,51	12,31
	CR		1,00	0,60	0,34	0,17
	P	14,01	12,33	7,97	5,21	3,67
	COP (part load)		2,87	4,62	7,07	6,70
	COP (full load)		2,87	4,00	4,70	5,70
	Fcop		1,00	1,16	1,50	1,18
Data to be provided for power and COP under full load cold source air		Te				
7.1	Te	Tm	-7	2	7	12
	Heating capacity ΦH,HP out (kW)	35°C	12,33	12,71	14,51	12,31
		45°C	11,27	11,21	14,00	11,61
		55°C	10,35	11,71	13,85	10,94
	COP	35°C	2,87	4,00	4,70	5,70
		45°C	2,61	3,11	3,65	4,61
		55°C	2,18	2,91	3,05	3,80
DHW Power and COP data under full load		Te				
7.1	Te	Tm	7	15	20	35
	Heating capacity ΦH,HP out (kW)	55°C	13,85	12,35	13,76	16,51
	COP	55°C	3,05	4,21	4,60	4,25

Terms and definitions

Tm = Delivery temperature

Tdesignh = A - Average design climate temperature (pursuant to UNI EN 14825)

A, B, C, D = names of the four conditions with which different outdoors air temperatures are associated (Te)

Te = Outdoors air temperature

PLR = part load ratio

DC = power under full load referred to the specified temperatures

CR = heat pump load factor

P = system power demand

COP' (full load) = COP under full load referred to the indicated outdoors air temperatures

COP' (part load) = COP under partial load referred to the indicated outdoors air temperatures

fCOP = COP correction factor, as follows: COP' (full load) / COP (part load)HP= heat pump

DHW = domestic hot water

# Data for the UNI/TS 11300 calculation

## SPHERA EVO 2.0 - Size 8.1

Data for determination of COPPL T delivery 20°C		Tdesignh	A	B	C	D
8.1	Te	-10	-7	2	7	12
	PLR	100%	88%	54%	35%	15%
	DC		13,82	14,30	16,01	15,20
	CR		1,00	0,59	0,34	0,16
	P	15,71	13,82	8,55	5,88	3,67
	COP (part load)		2,86	4,59	7,13	6,44
	COP (full load)		2,86	3,85	4,55	5,43
	Fcop		1,00	1,19	1,57	1,19
Data to be provided for power and COP under full load cold source air		Te				
8.1	Te	Tm	-7	2	7	12
	Heating capacity ΦH,HP out (kW)	35°C	13,82	14,30	16,01	15,20
		45°C	12,35	13,79	16,01	14,55
		55°C	11,23	13,32	16,00	13,91
	COP	35°C	2,86	3,85	4,55	5,43
		45°C	2,58	3,28	3,60	4,49
		55°C	2,13	2,80	2,90	4,00
	DHW Power and COP data under full load		Te			
8.1	Te	Tm	7	15	20	35
	Heating capacity ΦH,HP out (kW)	55°C	16,00	13,91	13,90	16,68
	COP	55°C	2,90	4,39	4,86	4,49

### Terms and definitions

Tm = Delivery temperature

Tdesignh = A - Average design climate temperature (pursuant to UNI EN 14825)

A, B, C, D = names of the four conditions with which different outdoors air temperatures are associated (Te)

Te = Outdoors air temperature

PLR = part load ratio

DC = power under full load referred to the specified temperatures

CR = heat pump load factor

P = system power demand

COP' (full load) = COP under full load referred to the indicated outdoors air temperatures

COP' (partial load) = COP under partial load referred to the indicated outdoors air temperatures

fCOP = COP correction factor, as follows: COP' (full load) / COP (partial load)HP= heat pump

DHW = domestic hot water

# Data for the UNI/TS 11300 calculation

The specified data refer to the nominal power values under the declared conditions

## UNI/TS 11300 Part 3

SIZE	Cooling capacity kW				EER				
	Test	1	2	3	4	1	2	3	4
		100%	75%	50%	25%	100%	75%	50%	25%
<b>220-240V N 50Hz</b>									
<b>2.1</b>		4,26	3,20	2,05	0,90	3,50	4,71	5,84	5,81
<b>3.1</b>		6,25	4,59	2,96	1,35	3,09	4,43	6,17	7,40
<b>4.1</b>		7,46	5,20	3,51	1,63	3,33	4,48	6,67	9,30
<b>5.1</b>		9,10	6,43	4,25	1,94	3,09	4,26	6,73	10,48
<b>6.1</b>		11,80	8,89	6,01	2,91	2,75	3,89	5,73	7,88
<b>7.1</b>		12,86	9,40	6,29	2,91	2,55	3,78	5,71	7,88
<b>8.1</b>		14,20	10,53	7,12	2,91	2,45	3,54	5,38	7,88

Reference conditions prescribed by UNI/TS 11300-3:

1. External air temperature B.S. 35°C Refrigerated water temperature at the fancoil inlet/outlet 12/7 °C
2. External air temperature B.S. 30°C Refrigerated water temperature at the fancoil outlet /7 °C
3. External air temperature B.S. 25°C Refrigerated water temperature at the fancoil outlet /7 °C
4. External air temperature B.S. 20°C Refrigerated water temperature at the fancoil outlet /7 °C

Compared to traditional systems, SPHERA EVO 2.0 provides numerous advantages from an economic point of view and in terms of energy. Below is a real case in a domestic system before and after replacing a gas boiler with a SPHERA EVO 2.0 solution.

## Natural gas

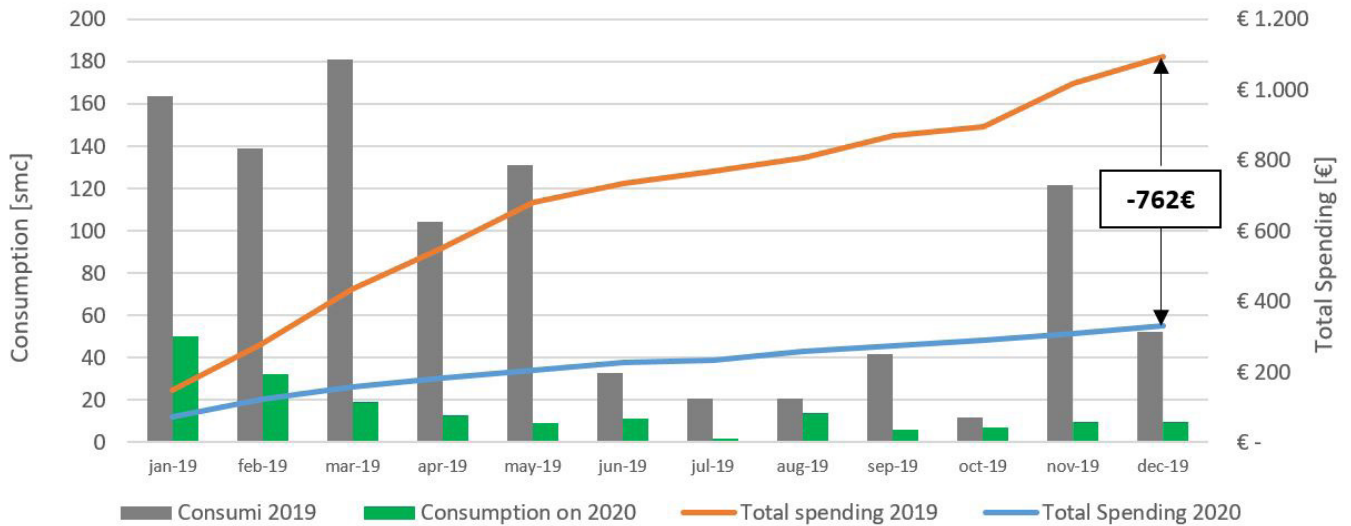

## Electricity

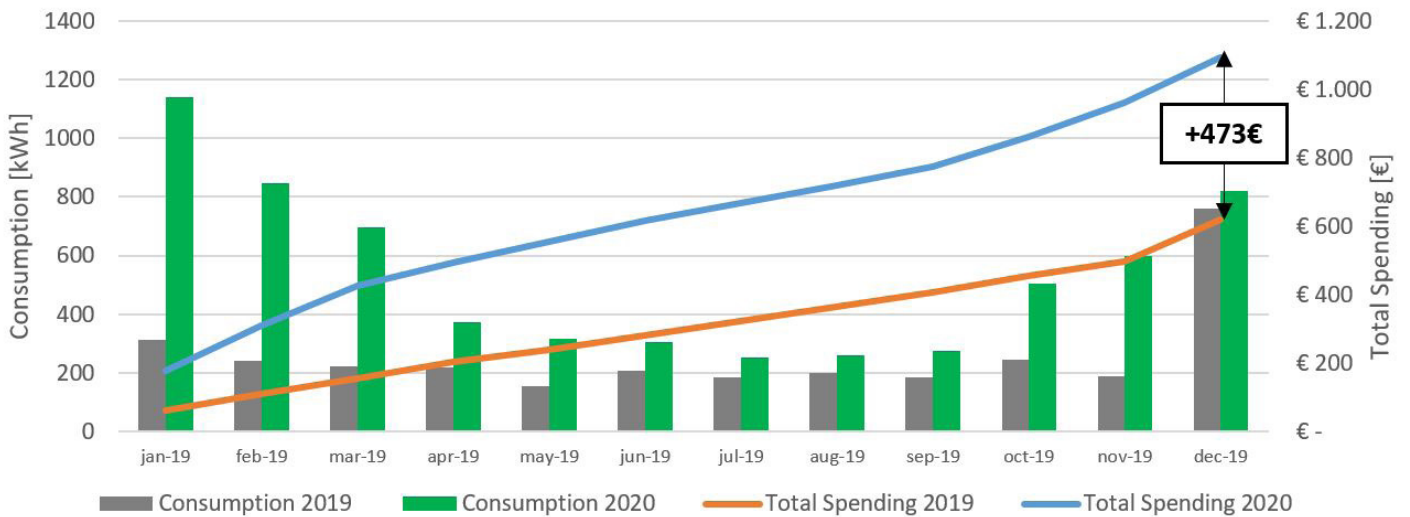

The graphs show the consumption and cost of natural gas and electricity for 2019 and 2020 (heat pump installed at the end of December 2019).

Year	Natural gas cost	Electricity cost	Total cost	Savings
2019	1092 €	620 €	1712 €	289 € -20%
2020	330 €	1093 €	1423 €	

The savings were obtained without changing any aspect of the previous system except for the heat generator. The heating terminals are radiators with an operating temperature of 55°C. The use of low temperature terminals (underfloor heating) would allow for double the amount of savings.

# EuroSwitch Function

SPHERA EVO 2.0 provides a useful instrument for maximising savings, for hybrid systems with a gas boiler, through the EuroSwitch function. Based on the set price of natural gas and electricity, the heat pump will assign priority to its own operation rather than that of the boiler depending on its efficiency. The aim is to always use the most cost-effective heat source.

## Case 1 - Typical day in January - Radiators (supply temperature = 55°C)

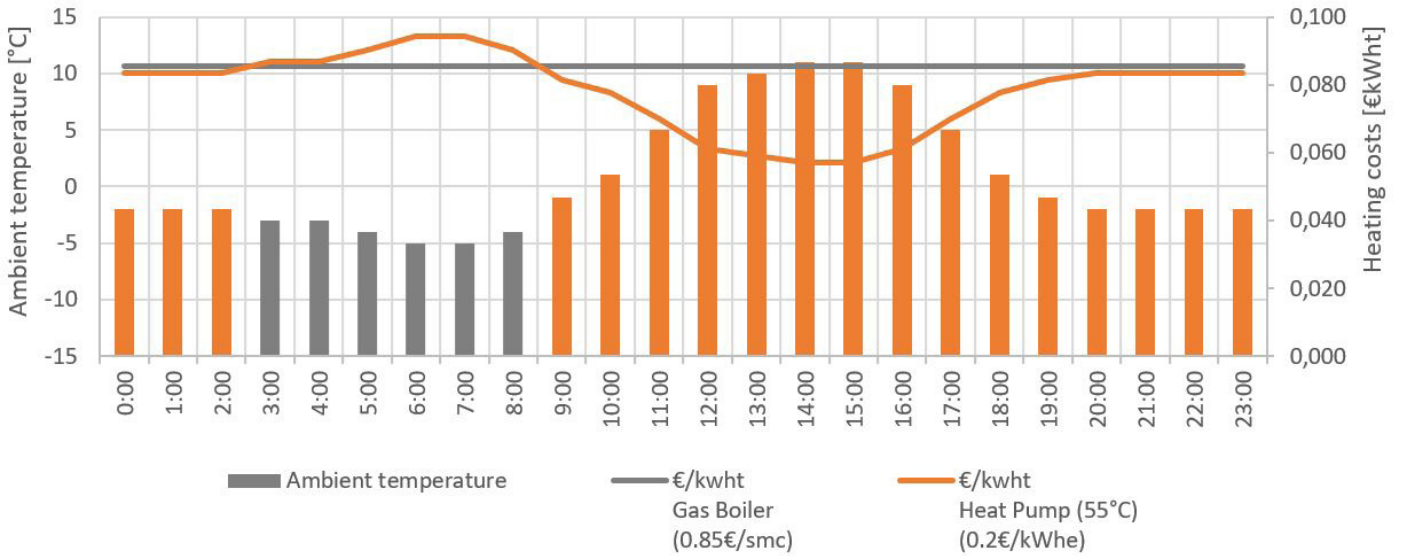

From 03:00am to 08:00am, heat will be produced by the boiler, while during other time slots, it will be produced by the heat pump.

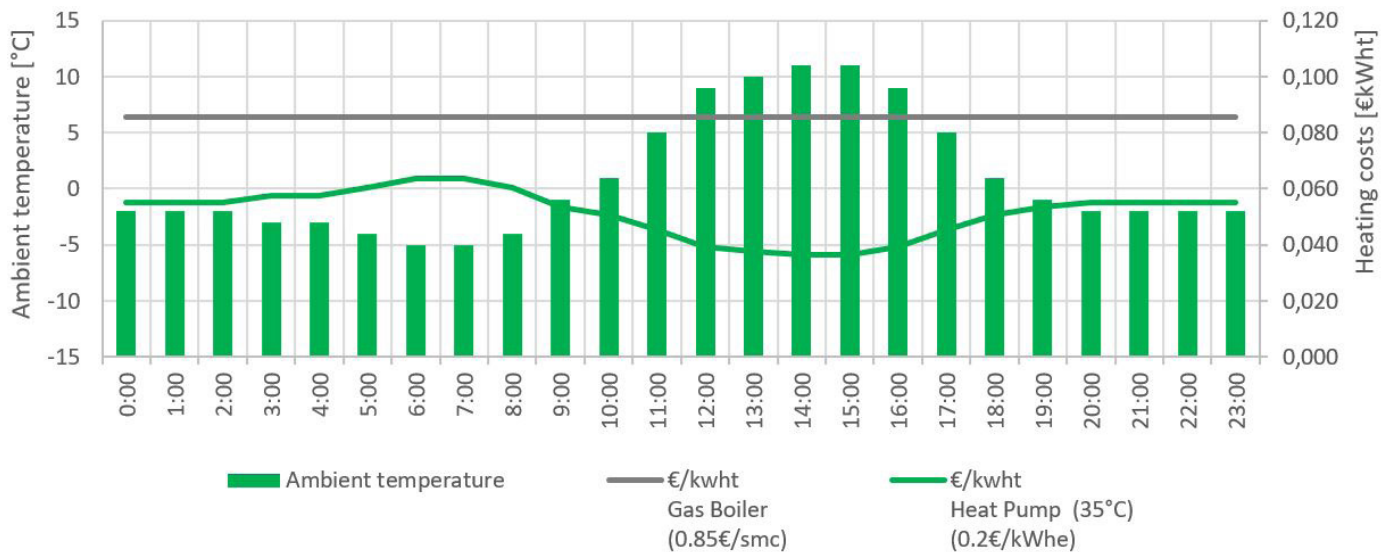

## Case 2 - Typical day in January - Radiant floor (supply temperature = 35°C)

Heat will be produced by the heat pump during the whole day.

The graphs show the trend of the daily temperature and of the cost for thermal energy. The heat pump's efficiency varies according to the outdoor temperature and the water temperature, while the boiler has a fixed efficiency. The calculations consider an average cost of natural gas equal to 0.85 €/SCM and of electricity equal to 0.2 €/SCM.

## SPHERA EVO 2.0 - SQKN-YEE 1 TC A TOWER 190 L

DAAGL0001 REV00  
DATA/DATE 07/06/2021

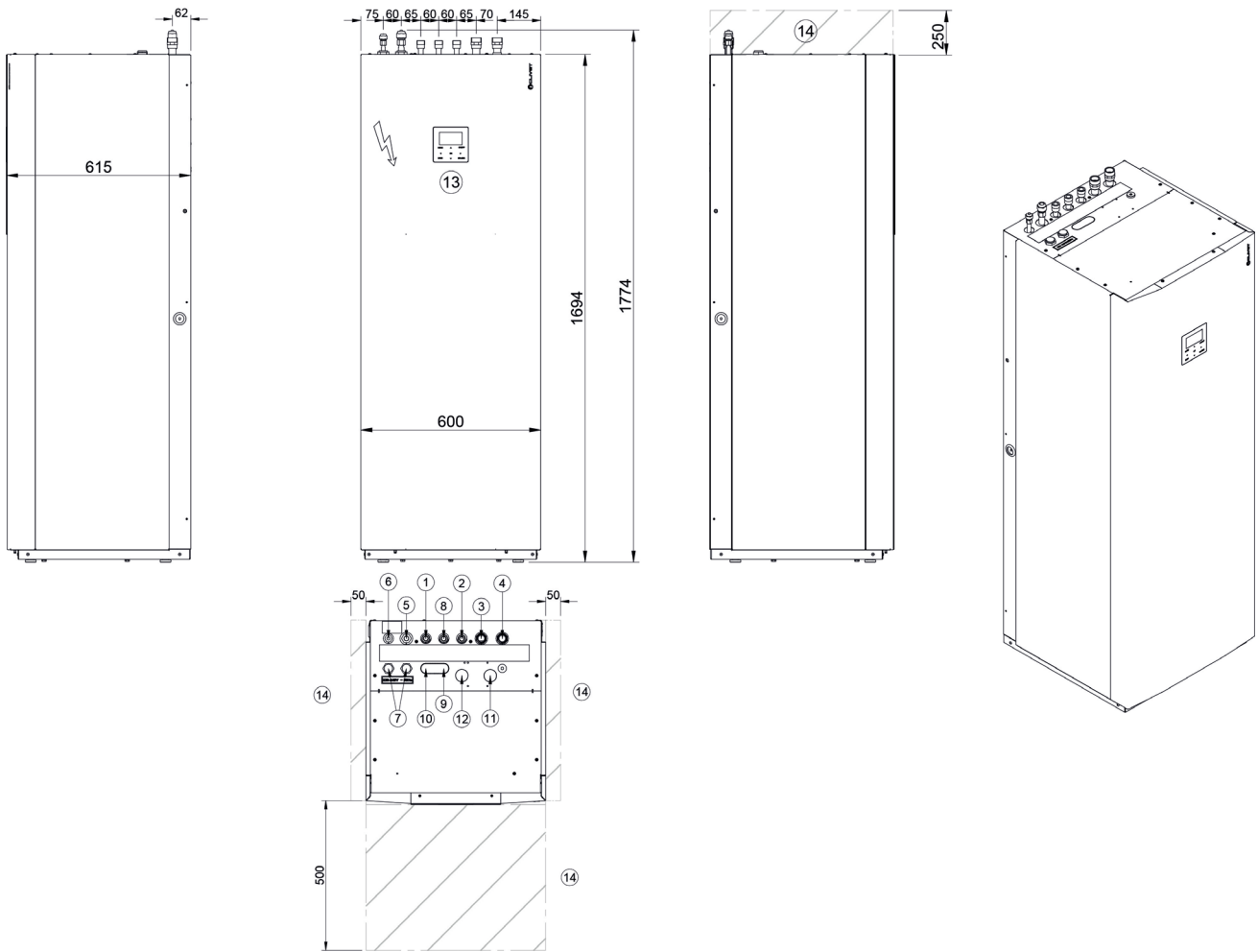

1. Domestic hot water outlet M 3/4"
2. Mains inlet M 3/4"
3. Return for the utility installation M 1"
4. Supply to the utility installation M 1"
5. Return connection 5/8" SAE (\*)
6. Liquid connection 3/8" SAE (\*)
7. Electrical line inlet
8. DHW recirculation circuit M 3/4"
9. Solar system outlet M 3/4" (optional accessory)
10. Solar system inlet M 3/4" (optional accessory)
11. Gas boiler outlet M 1" (optional accessory)
12. Gas boiler inlet M 1" (optional accessory)
13. Control keypad
14. Functional spaces for standard unit

(\*) see instructions in kit RGGL00009

SIZE		190 L
Operation weight	kg	359
Shipping weight	kg	187

The presence of optional accessories may result in a substantial variation of the weights shown in the table.



# Dimensional drawings

## SPHERA EVO 2.0 - SQNK-YEE 1 TC A-B TOWER 250 L

DAAGL0002 REV00  
DATA/DATE 07/06/2021

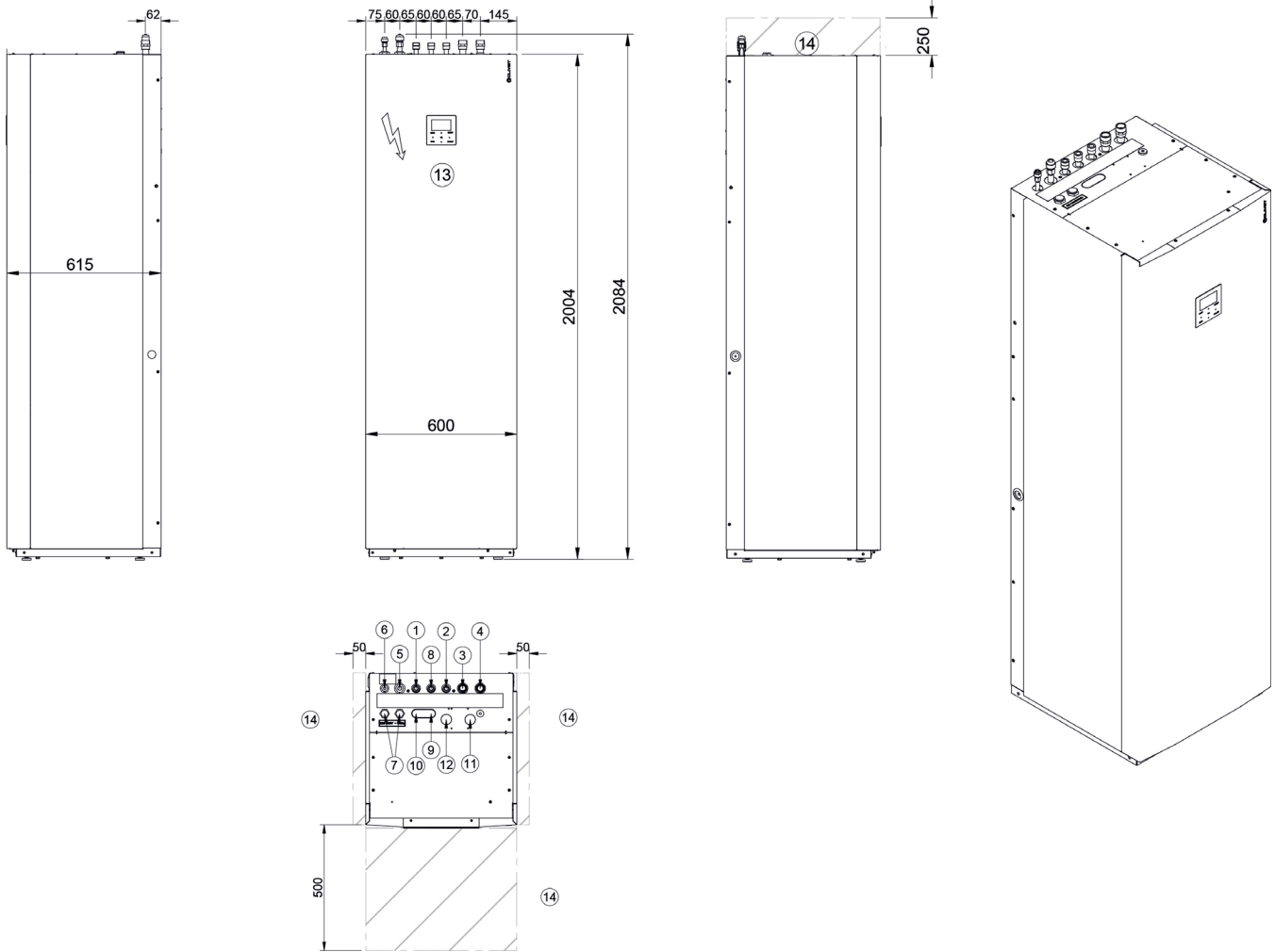

1. Domestic hot water outlet M 3/4"
2. Mains inlet M 3/4"
3. Return for the utility installation M 1"
4. Supply to the utility installation M 1"
5. Return connection 5/8" SAE (\*)
6. Liquid connection 3/8" SAE (\*)
7. Electrical line inlet
8. DHW recirculation circuit M 3/4"
9. Solar system outlet M 3/4" (optional accessory)
10. Solar system inlet M 3/4" (optional accessory)
11. Gas boiler outlet M 1" (optional accessory)
12. Gas boiler inlet M 1" (optional accessory)
13. Control keypad
14. Functional spaces for standard unit

(\*) see instructions in kit RGGL00001

RANGE		GABC	GBBC
SIZE		250 L	250 L
Operation weight	kg	419	421
Shipping weight	kg	192	194

The presence of optional accessories may result in a substantial variation of the weights shown in the table.

## SPHERA EVO 2.0 (outdoor unit) - 2.1 - 3.1

DAAQ80002\_REV00  
DATA/DATE 29/04/2021

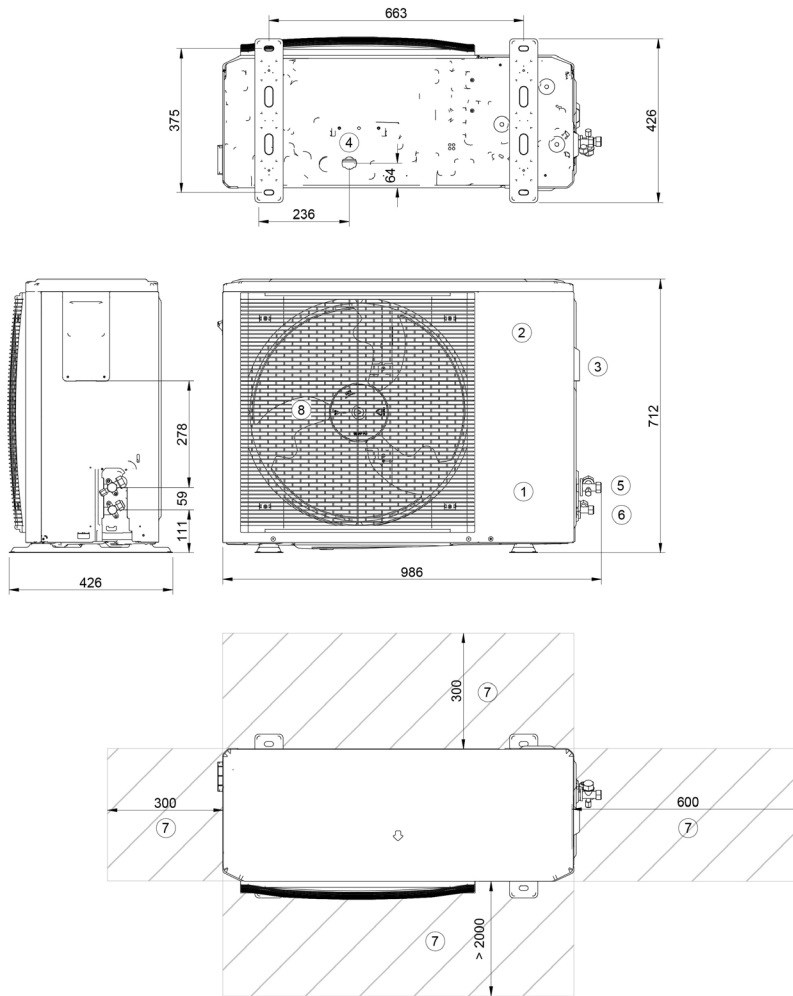

1. Compressor enclosure
2. Electrical panel
3. Power input
4. Condensate drain
5. Gas connections (1/4")
6. Gas connections (5/8")
7. Functional spaces
8. Electrical fan

SIZE		2.1	3.1
Operation weight	kg	58	58
Shipping weight	kg	64	64

The presence of optional accessories may result in a substantial variation of the weights shown in the table.

# Dimensional drawings

## SPHERA EVO 2.0 (outdoor unit) - 4.1 - 8.1

DAAQ80001\_REV01  
DATA/DATE 29/01/2021

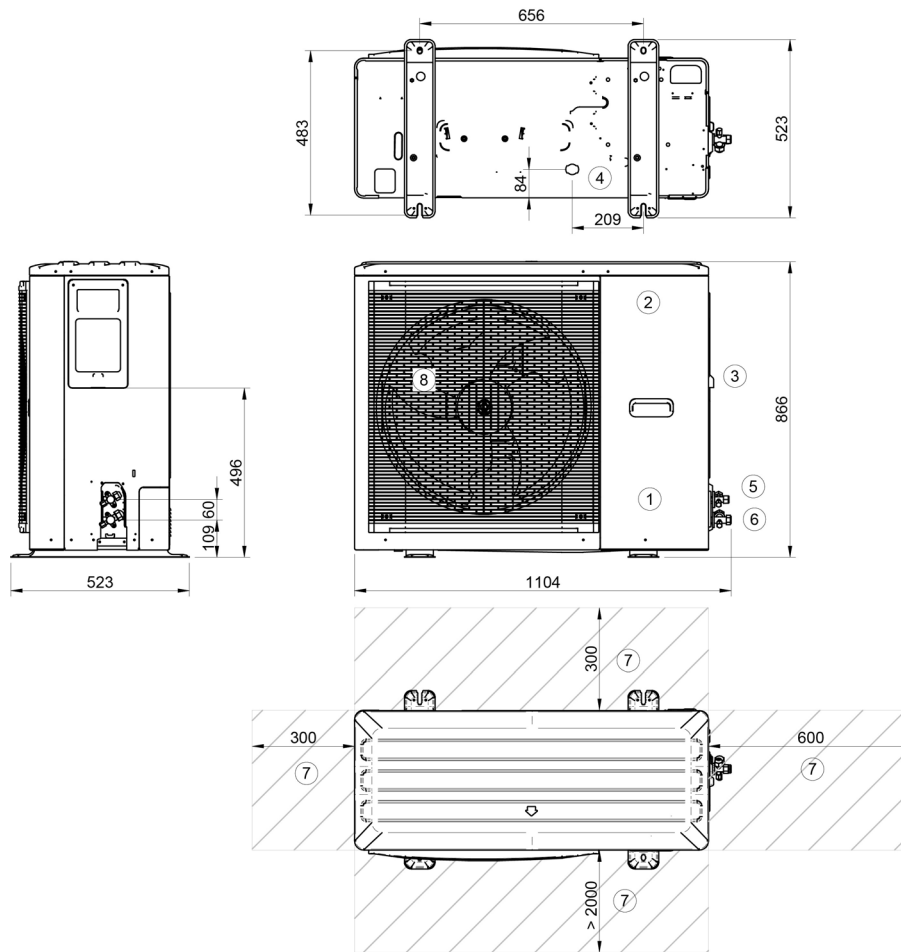

1. Compressor enclosure
2. Electrical panel
3. Power input
4. Condensate drain
5. Gas connections (3/8")
6. Gas connections (5/8")
7. Functional spaces
8. Electrical fan

SIZE		4.1 / 1Ph	5.1 / 1Ph	6.1 / 1Ph	6.1 / 3Ph	7.1 / 1Ph	7.1 / 3Ph	8.1 / 1Ph	8.1 / 3Ph
Operation weight	kg	77	77	96	112	96	112	96	112
Shipping weight	kg	88	88	110	125	110	125	110	125

The presence of optional accessories may result in a substantial variation of the weights shown in the table.

## GAS BOILER UC

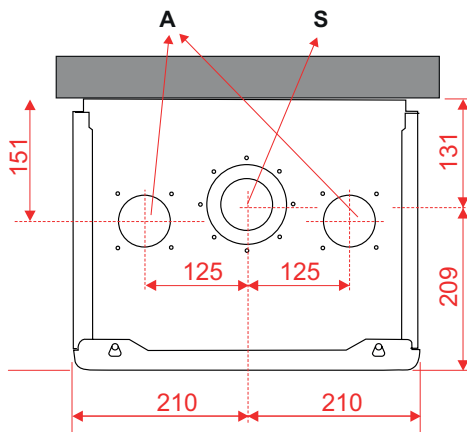
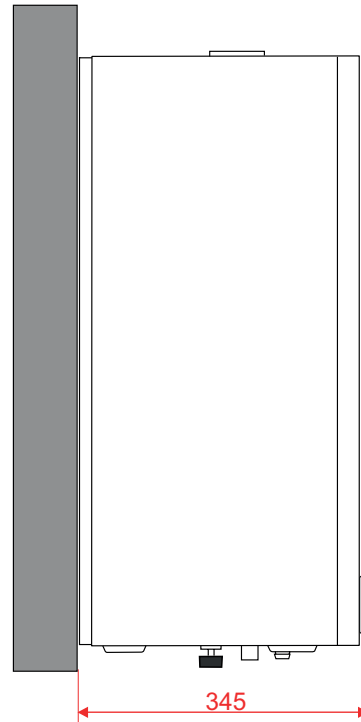
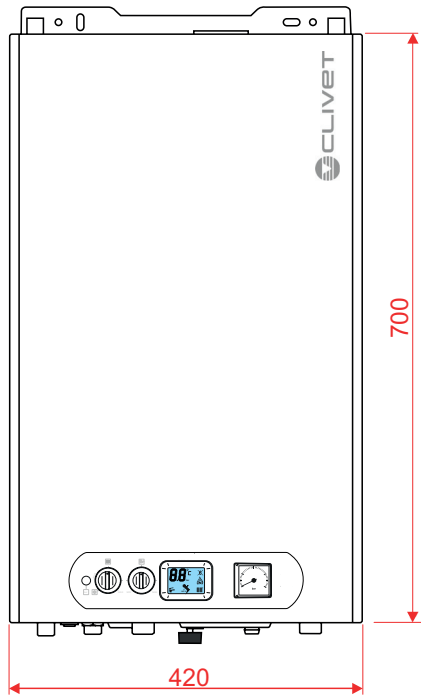

View from above

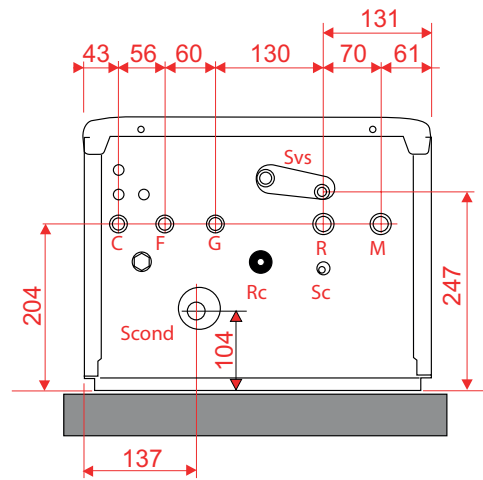

Seen from below

- M = System supply Ø 3/4"
- R = System return Ø 3/4"
- G = Gas Ø 3/4"
- F = Cold DHW inlet Ø 1/2"
- C = Hot DHW outlet Ø 1/2"
- SC = Condensate drain (Ø 18,1)
- A = Air intake Ø 80
- S = Smoke exhaust Ø 80

# Dimensional drawings

## GAS BOILER FE 24.4

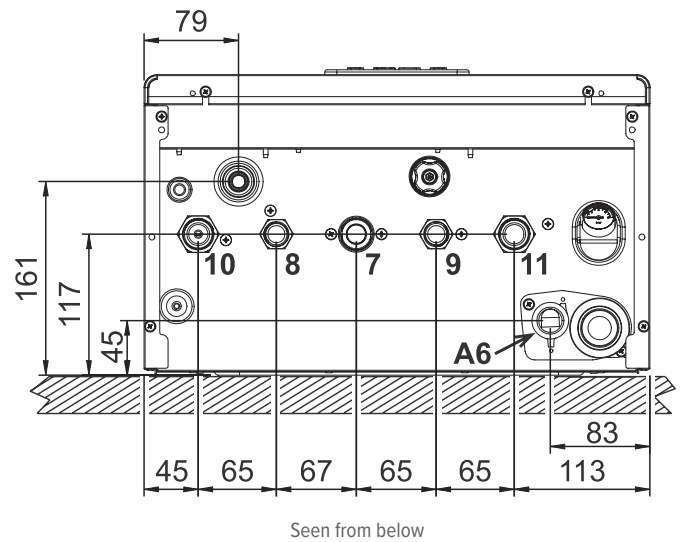
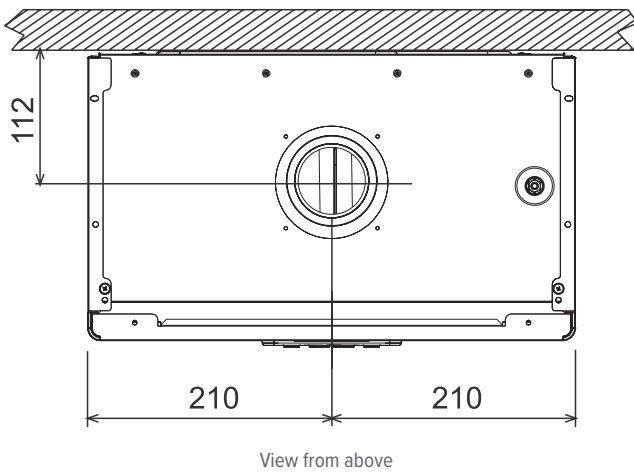
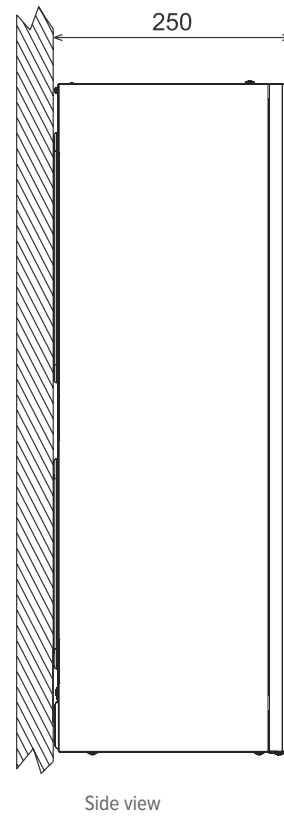
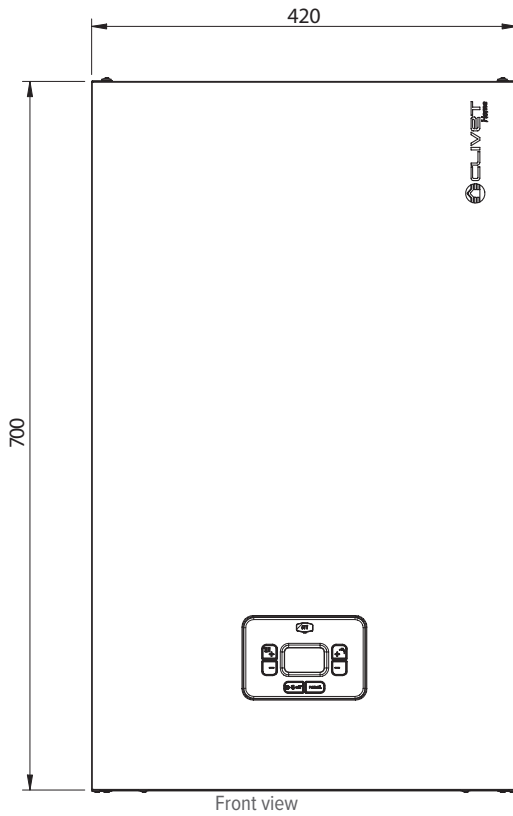

- 10 = System supply  $\varnothing$  3/4"
- 11 = System return  $\varnothing$  3/4"
- 7 = Gas  $\varnothing$  3/4"
- 9 = Cold DHW inlet  $\varnothing$  1/2"
- 8 = Hot DHW outlet  $\varnothing$  1/2"
- A6 = Condensate drain ( $\varnothing$  22,5)
- Air intake and Smoke exhaust  $\varnothing$  80

## GAS BOILER FE 33.4

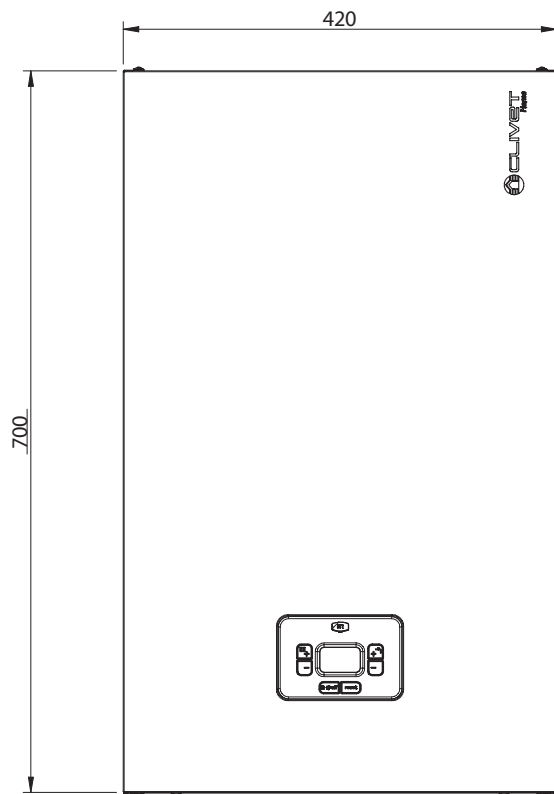

Vista frontale

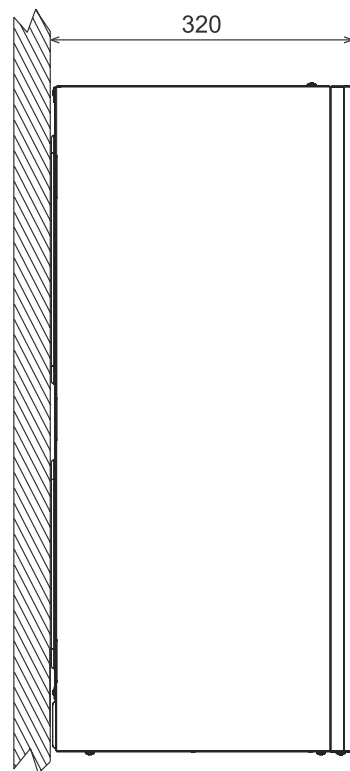

Side view

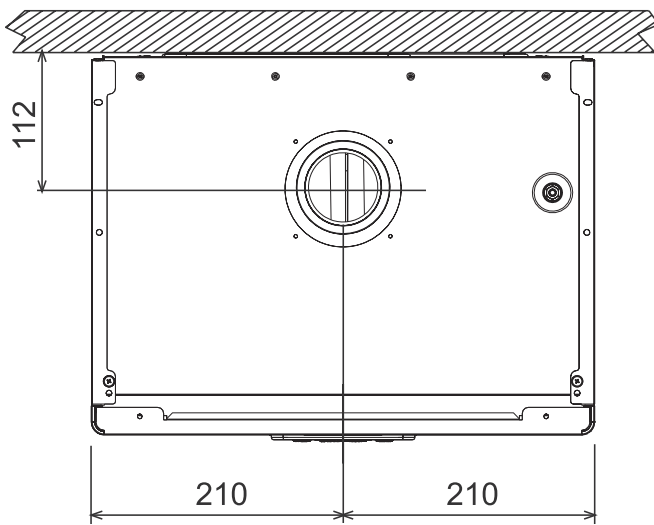

View from above

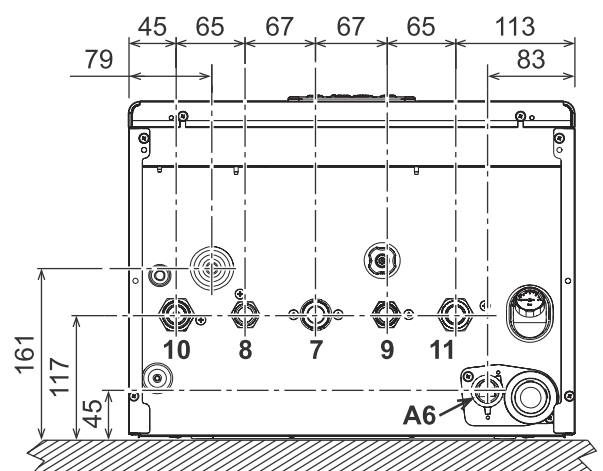

Seen from below

- 10 = System supply  $\varnothing$  3/4"
- 11 = System return  $\varnothing$  3/4"
- 7 = Gas  $\varnothing$  3/4"
- 9 = Cold DHW inlet  $\varnothing$  1/2"
- 8 = Hot DHW outlet  $\varnothing$  1/2"
- A6 = Condensate drain ( $\varnothing$  22,5)
- Air intake and Smoke exhaust  $\varnothing$  80

Page intentionally left blank

FOR OVER 30 YEARS WE HAVE BEEN  
OFFERING SOLUTIONS TO ENSURE  
SUSTAINABLE COMFORT AND THE WELL-  
BEING OF PEOPLE AND THE ENVIRONMENT

[www.clivet.com](http://www.clivet.com)

**MideaGroup**  
*humanizing technology*

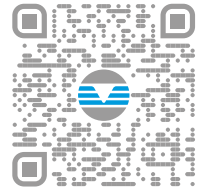

sale and assistance

SPHERA EVO 2.0 Tower - BT21F058GB-05



**CLIVET S.p.A.**

Via Camp Lonc 25, Z.I. Villapaiera  
32032 Feltre (BL) - Italy  
Tel. +39 0439 3131 - [info@clivet.it](mailto:info@clivet.it)

**CLIVET GMBH**

Hummelsbütteler Steindamm 84,  
22851 Norderstedt, Germany  
Tel. +49 40 325957-0 - [info.de@clivet.com](mailto:info.de@clivet.com)

**Clivet Group UK LTD**

Units F5 & F6 Railway Triangle,  
Portsmouth, Hampshire PO6 1TG  
Tel. +44 02392 381235 -  
[Enquiries@Clivetgroup.co.uk](mailto:Enquiries@Clivetgroup.co.uk)

**CLIVET LLC**

Office 508-511, Elektroavodskaya st. 24,  
Moscow, Russian Federation, 107023  
Tel. +7495 6462009 - [info.ru@clivet.com](mailto:info.ru@clivet.com)

**CLIVET MIDEAST FZCO**

Dubai Silicon Oasis (DSO), High Bay Complex,  
Office N. 20, PO BOX 342009, Dubai, UAE  
Tel. +971 (0) 4501 5840 - [info@clivet.ae](mailto:info@clivet.ae)

**Clivet South East Europe**

Jarušćica 9b  
10000, Zagreb, Croatia  
Tel. +385916065691 - [info.see@clivet.com](mailto:info.see@clivet.com)

**Clivet Airconditioning Systems Pvt Ltd**

Office No.501 & 502,5th Floor, Commercial -I,  
Kohinoor City, Old Premier Compound, Off  
LBS Marg, Kiroi Road, Kurla West, Mumbai  
Maharashtra 400070, India  
Tel. +91 22 30930200 - [sales.india@clivet.com](mailto:sales.india@clivet.com)