



CSRN-Y

60.4 - 120.4

**Manual
for installation,
use and maintenance**



M09V00002-00 01/2023

Keep this manual with the wiring diagram in an accessible place for the operator, for future reference.

Dear Customer,

We congratulate you on choosing these product

Clivet has been working for years to offer systems able to assure the maximum comfort for a long time with highly-reliable, efficient, high-quality and safe solutions.

The target of the company is to offer advanced systems, that assure the best comfort and reduce energy consumption as well as the installation and maintenance costs for the entire life-cycle of the system.

With this manual, we want to give you information that are useful for all phases: from reception, installation and use to disposal - so that such an advanced system can provide the best performances during installation and use.

Best regards and have a good read.

CLIVET Spa

The original instructions are written in Italian.

All other languages are translations of the original instructions.

The data contained in this manual is not binding and may be changed by the manufacturer without prior notice. Reproduction, even partial, is FORBIDDEN.

© Clivet S.p.A. - Feltre (BL) - Italia

Pay particular attention to:



INSTALLER use



USER use

Summary

1.	Safety considerations	7
1.1	Safety	7
1.2	Manual	7
1.3	Risk situations	7
1.4	Intended use	7
1.5	Installation.....	7
1.6	Maintenance.....	7
1.7	Modification.....	7
1.8	Breakdown/Malfunction	7
1.9	User training.....	7
1.10	Data update.....	8
2.	Indications for the User	9
2.1	In case of breakdown or malfunction	9
2.2	The installer must train the user, particularly on:.....	9
2.3	Unit identification	9
2.4	Serial number.....	9
2.5	Assistance request.....	9
3.	Information on refrigerant gas	10
4.	Configuration	11
5.	Before installation	15
5.1	Safety	15
5.2	Reception.....	15
5.3	Storage	15
5.4	Removal of packaging.....	15
5.5	Handling.....	15
5.6	Lifting.....	15
6.	Selecting the installation site	17
6.1	Positioning	17

6.2	Functional spaces.....	17
6.3	Positioning.....	17
6.4	External air hood.....	19
6.5	Gas heating module.....	20
6.6	UV-C lamps.....	24
7.	Water connections.....	25
7.1	Condensation in winter operation.....	25
7.2	Risk of freezing.....	25
7.3	Immerged electrodes humidifier.....	26
7.4	Heating coil.....	27
8.	Aeraulic connections.....	28
8.1	Treated air channelling.....	28
9.	Electrical connections.....	29
9.1	Electrical data.....	29
9.2	Connections.....	29
9.3	Power supply network requirements.....	29
9.4	Signals / data lines.....	29
9.5	Power input.....	30
9.6	Remote control with user interface.....	33
9.7	ModBUS.....	34
9.8	BACnet IP.....	35
9.9	LONWORKS.....	35
9.10	BACnet MSTP.....	36
10.	Start-up.....	37
10.1	UV-C lamps.....	37
10.2	Start-up sequence.....	38
10.3	Start-up sequence.....	39
10.4	Refrigeration circuit.....	40
10.5	Water circuit.....	40
10.6	Electric Circuit.....	40
10.7	Compressor casing heater.....	40
10.8	Fire alarm: configuration.....	41
10.9	Start-up report.....	41
10.10	2014/68/UE PED directive.....	41
11.	Control.....	42

11.1	Operational modes.....	43
11.2	Setpoint (temperature)	43
11.3	Parameters menu.....	44
11.4	Setpoint.....	44
11.5	Stata menu.....	45
11.6	Date and hour	46
11.7	Button lock.....	46
11.8	To visualize alarm in progress	47
11.9	Scheduler.....	48
11.10	Service keypad.....	52
11.11	Main menu	53
11.12	Scheduler.....	53
11.13	Keyboard settings.....	54
11.14	To Visualize alarm in progress	54
11.15	Reset alarm.....	54
11.16	Main menù installer use	55
11.17	Alarms	56
11.18	States	57
12.	SAFETY WARNINGS FOR OPERATIONS ON UNITS CONTAINING R32.....	58
12.1	Area checks.....	58
12.2	Work procedures	58
12.3	General work area.....	58
12.4	Check the presence of refrigerant.....	58
12.5	Presence of the fire extinguisher.....	58
12.6	No ignition source	58
12.7	Ventilated area	58
12.8	Cooling equipment checks	58
12.9	Electrical device checks.....	58
12.10	Repairing sealed components	58
12.11	Reparation of intrinsically safe components.....	59
12.12	Wires	59
12.13	Detection of flammable refrigerants.....	59
12.14	Leak detection methods	59
12.15	Removal and evacuation	59
12.16	Charging operations	59
12.17	Dismantling.....	60

12.18	Labelling	60
12.19	Recovery	60
12.20	Transport, mark and storage.....	60
13.	Maintenance.....	62
13.1	Safety	62
13.2	General	62
13.3	Frequency of interventions	62
13.4	Recommended periodic checks sheet	63
13.5	Unit booklet.....	64
13.6	Structure.....	64
13.7	Outdoor air coil.....	64
13.8	Indoor air coil	64
13.9	Condensation collection basin.....	64
13.10	G4 (ISO 16890 Coarse 60%) Folded air filters	64
13.11	F7 filters (ISO 16890 and PM1 55%)/F9 (ISO 16890 ePM1 80%).....	64
13.12	IFD Electronic filters (ISO 16890 and PM1 90%).....	65
13.13	Electric heaters.....	65
13.14	Compressor casing heater	65
13.15	Immerged electrodes humidifier	66
14.	Decommissioning	67
14.1	Disconnection	67
14.2	WEEE INFORMATION	67
15.	Residual risks	68
16.	Technical information	70
17.	Dimensional	74



1. Safety considerations

1.1 Safety

Operate in compliance with safety regulations in force.

To carry out the operations use protection devices:

gloves, goggles, helmet, headphones, protective knee pads.

All operations must be carried out by personnel trained on possible risks of a general nature, electrical and deriving from operating with equipment under pressure.

Only qualified personnel can operate on the unit, as required by the regulation in force



BEFORE ANY WORK READ:

⚠ Chapter. SAFETY WARNINGS FOR OPERATIONS ON UNITS CONTAINING R32



PAY PARTICULAR ATTENTION TO:

⚠ warnings / prohibitions / danger indicating particularly important operations or information, operations that cannot be done, which compromise the functionality of the unit or which may cause damage to things or persons.

1.2 Manual

The manual provides correct unit installation, use and maintenance.

It is advisable to read it carefully so you will save time during operations.

Follow the written indications so you will not cause damages to things and injuries people.

1.3 Risk situations

The unit has been designed and created to prevent injuries to people.

During designing it is not possible to plane and operate on all risk situation.

Read carefully “Residual risk” section where all situation which may cause damages to things and injuries to people are reported.

Installation, starting, maintenance and repair required specific knowledge; if they are carried out by inexperienced personnel, they may cause damages to things and injuries people.

1.4 Intended use

Use the unit only:

- civil air-conditioning

keep to the limits foreseen in the technical schedule and in this manual

The manufacturer accepts no responsibility if the equipment is used for any purpose other than the intended use.

1.5 Installation

Outdoor installation

The positioning, hydraulic system, refrigerating, electrics and the ducting of the air must be determined by the system designer in accordance with local regulations in force.

Follow local safety regulations.

Verify that the electrical line characteristics are in compliance with data quotes on the unit serial number label.

1.6 Maintenance

Plan periodic inspection and maintenance in order to avoid or reduce repairing costs.

Turn the unit off before any operation.

1.7 Modification

All unit modifications will end the warranty coverage and the manufacturer responsibility.

1.8 Breakdown/Malfunction

Disable the unit immediately in case of breakdown or malfunction.

Contact a certified service agent.

Use original spares parts only.

Using the unit in case of breakdown or malfunction:

- voids the warranty
- it may compromise the safety of the unit
- it may increase time and repair costs

1.9 User training

The installer has to train the user on:

- Start-up/shutdown





- Set points change
- Standby mode
- Maintenance
- what to do / what not to do in case of alarm

1.10 Data update

Continual product improvements may imply manual data changes.

WARNING

 **This product contains fluorinated greenhouse gases covered by the Kyoto protocol.**

 **Do not discharge gas into the atmosphere**

Visit manufacturer web site for updated data.



2. Indications for the User

Keep this manual with the wiring diagram in an accessible place for the operator.

Note the unit data label so you can provide them to the assistance centre in case of intervention (see “Unit identification” section).

Provide a unit notebook that allows any interventions carried out on the unit to be noted and tracked making it easier to suitably note the various interventions and aids the search for any breakdowns.

2.1 In case of breakdown or malfunction

Immediately deactivate the unit

Contact a service centre authorized by the manufacturer

2.2 The installer must train the user, particularly on:

- Start-up/shutdown
- Set points change
- Standby mode
- Maintenance
- What to do / what not to do in case of breakdown

The installer must deliver the manual and wiring diagram to the User.

2.3 Unit identification

The serial number label is positioned on the unit and allows to identify all the unit features.

The matriculation plate shows the indications foreseen by the standards, in particular:

- unit type
- serial number (12 characters)
- year of manufacture
- wiring diagram number
- electrical data
- type of refrigerant
- refrigerant charge
- manufacturer logo and address

The matriculation plate must never be removed.

2.4 Serial number

It identifies uniquely each unit.

Must be quoted when ordering spare parts.

2.5 Assistance request

Note data from the serial number label and write them in the chart on side, so you will find them easily when needed.



3. Information on refrigerant gas

WARNING

This product contains fluorinated greenhouse gases covered by the Kyoto protocol.

Do not discharge gas into air.

Refrigerant type: R32

Characteristics of R32 refrigerant:

- minimum environmental impact thanks to the low Global Warming Potential GWP
- low flammability, class A2L according to ISO 817
- low combustion speed
- low toxicity

The refrigerant quantity is indicated on the unit plate

Size	Configuration	Refrigerant (kg)	Equivalent CO ² tons
60.4	CAK / CBK / CBK-G / CCK REVO	(C1) 32 + 33 (C2)	43,9
70.4	CAK / CBK / CBK-G / CCK REVO	(C1) 32 + 33 (C2)	43,9
80.4	CAK / CBK / CBK-G / CCK REVO	(C1) 33.5 + 34.5 (C2)	45,9
90.4	CAK / CBK / CBK-G / CCK REVO	(C1) 40 + 38 (C2)	52,7
100.4	CAK / CBK / CBK-G / CCK REVO	(C1) 42 + 40 (C2)	55,4
120.4	CAK / CBK / CBK-G / CCK REVO	(C1) 45 + 43 (C2)	59,4

Physical characteristics of the R32 refrigerant		
Safety class (ISO 817)	A2L	
GWP-AR4	675	
LFL Low flammability limit	0.307	kg/m ³ @ 60°C
BV Burning velocity	6,7	cm/s
Boiling point	-52	°C
GWP-AR5	675	100 yr ITH
GWP-AR5	677	ARS 100 yr ITH
Self-ignition temperature	648	°C

4. Configuration

CAK configuration

Single fan section for full recirculation

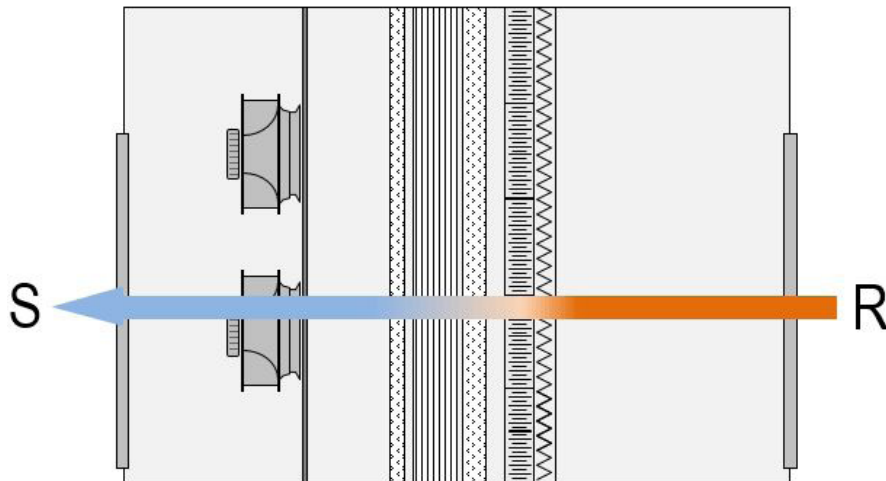

R Return air
S Supply air

CBK configuration

Single fan section for recirculation and fresh air

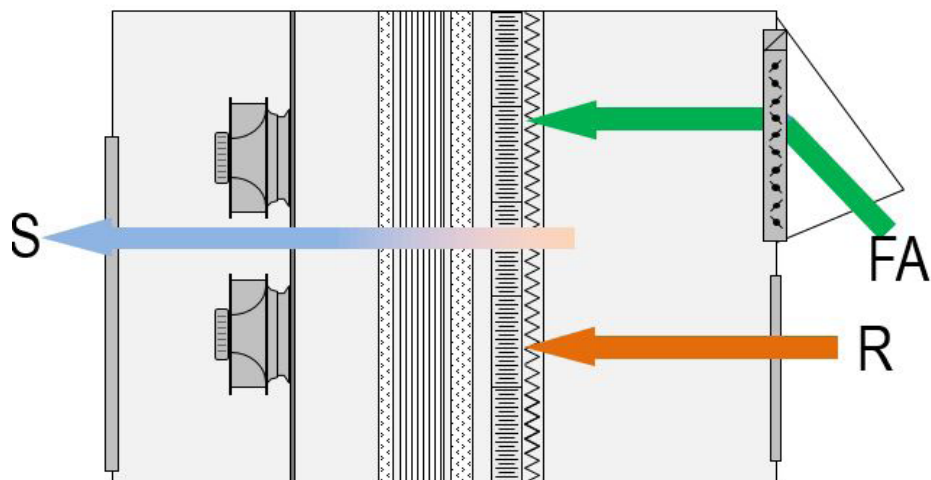

R Return air
S Supply air
FA Fresh air

CBK-G configuration

Single fan section for recirculation, fresh and exhaust air

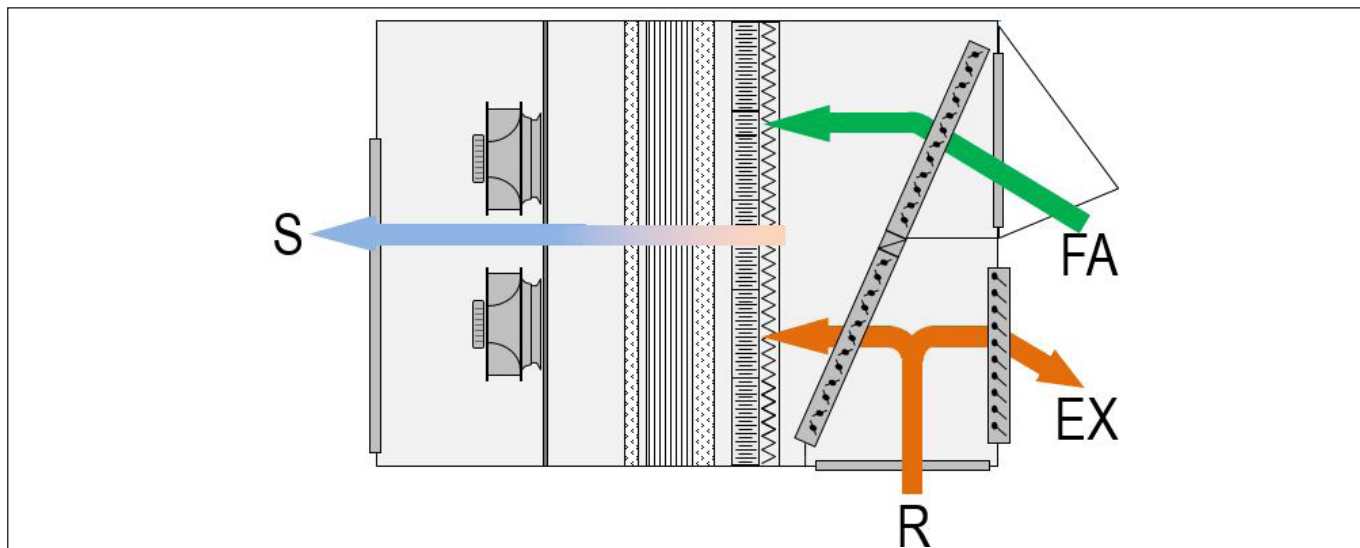

- R Return air
- S Supply air
- FA Fresh air
- EX Exhaust air

CBK-G configuration + enthalpy wheel

Fan section for recirculation, fresh and exhaust air with enthalpy wheel

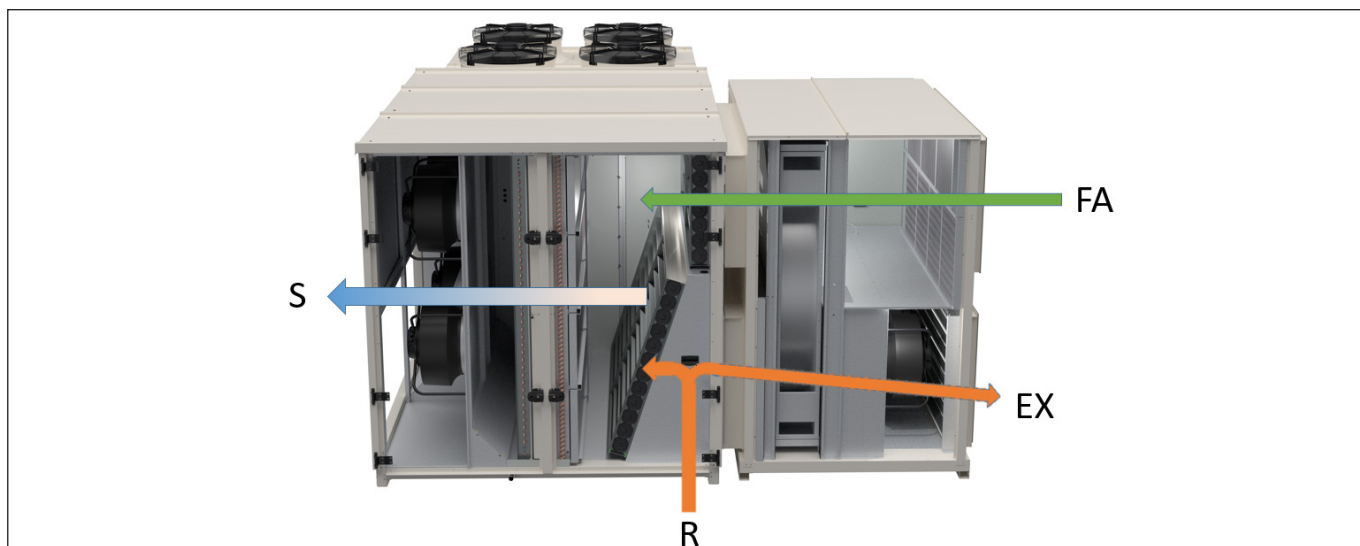

- R Return air
- S Supply air
- FA Fresh air
- EX Exhaust air

CCK-REVO configuration

Double fan section with fresh air and REVO thermodynamic recovery

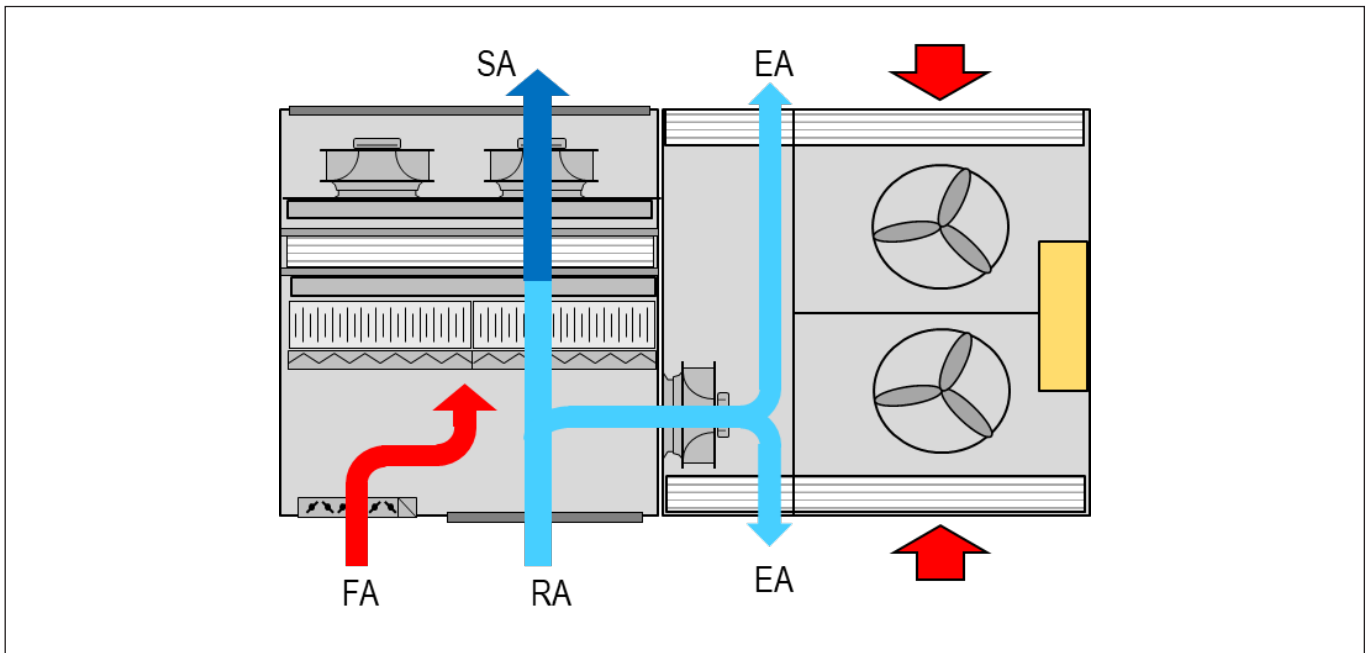

- RA Return air
- SA Supply air
- FA Fresh air
- EA Exhaust air

Supply and return configuration

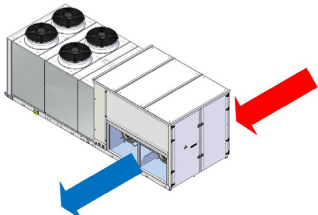
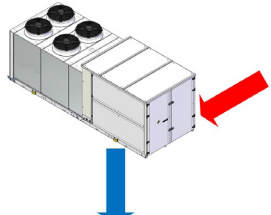
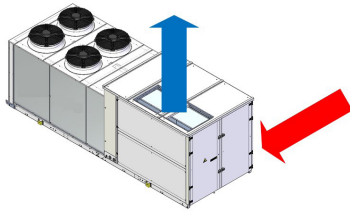
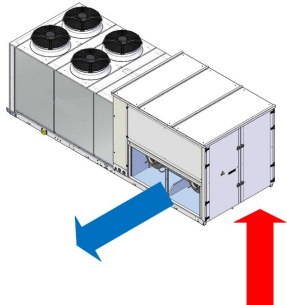
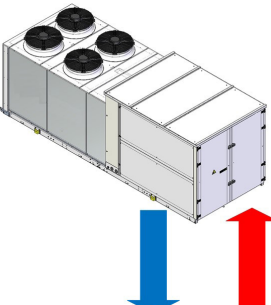
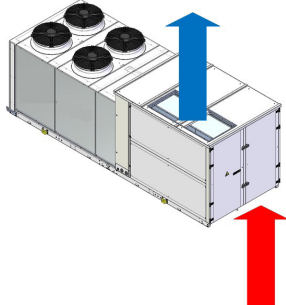
M0 - R0	M3 - R0	M5 - R0
Standard unit	Option	Option
		
M0 - R3	M3 - R3	M5 - R3
Option	Option	Option
		

Filters nomenclature according to EN ISO 16890

Filters nomenclature according to EN ISO 16890		
1° filtering stage - standard	G4	ISO 16890 Coarse 60%
2° filtering stage - option	F7	ISO 16890 ePM1 55%
2° filtering stage - option	F9	ISO 16890 ePM1 80%
2° filtering stage - option	FIFD (electrostatic filters)	ISO 16890 ePM1 90%



5. Before installation

5.1 Safety

Operate in compliance with safety regulations in force.

For detailed information (dimensions, weight, technical characteristics etc.) please refer to the TECHNICAL INFORMATION section.

Use single protection devices: gloves, glasses etc.

5.2 Reception

You have to check before accepting the delivery:

- That the unit hasn't been damaged during transport
- That the materials delivered correspond with that indicated on the transport document comparing the data with the identification label positioned on the packaging.

In case of damage or anomaly:

write down on the transport document the damage you found and quote this sentence: "Conditional acceptance clear evidence of deficiencies/damages during transport"

wontact by fax and registered mail with advice of receipt to supplier and the carrier.

WARNING

- ⚠ **Any disputes must be made within 8 days from the date of the delivery. Complaints after this period are invalid .**

5.3 Storage

Respect the indications on the outside of the pack.

In particular:

- minimum ambient temperature -10°C (possible components damages)
- maximum ambient temperature $+50^{\circ}\text{C}$ (possible safety valve opening)
- maximum relative humidity 95% (possible damages to electrical components)

WARNING

- ⚠ **The unit may not be tilted more than 15° during transport.**

5.4 Removal of packaging

Be careful not to damage the unit.

Recycle and dispose of the packaging material in compliance with local regulations.

5.5 Handling

WARNING

- ⚠ **Check that all handling equipment complies with local safety regulations (cran, forklifts, ropes, hooks, etc.).**

- ⚠ **Provide personnel with personal protective equipment suitable for the situation, such as helmet, gloves, accident-prevention shoes, etc.**

- ⚠ **Observe all safety procedures in order to guarantee the safety of the personnel present and the of material.**

5.6 Lifting



Verify unit weight and handling equipment lifting capacity.

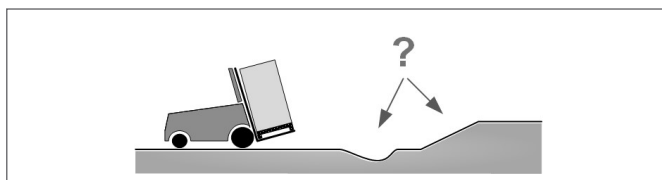

Identify critical points during handling (disconnected routes, flights, steps, doors).

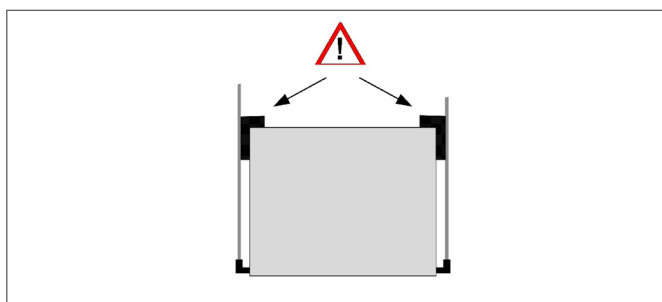

Suitably protect the unit to prevent damage.

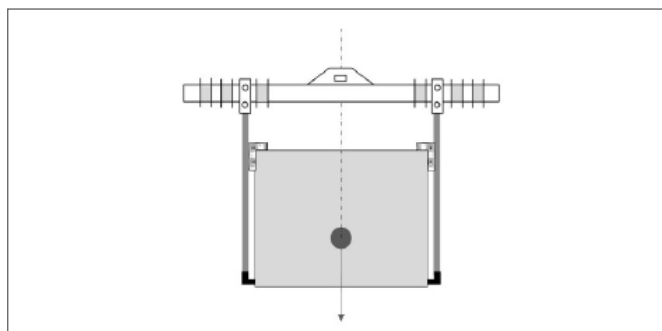

Lifting with balance

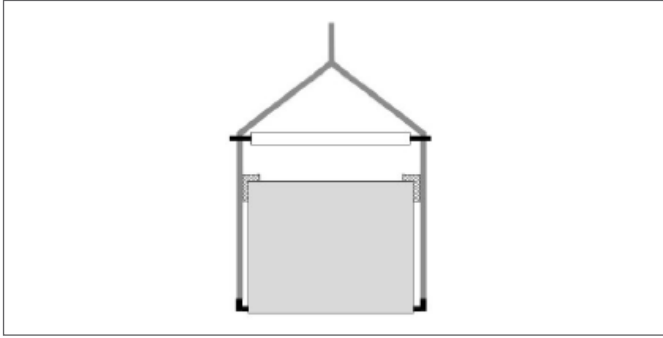

Lifting with spacer bar



Align the barycenter to the lifting point

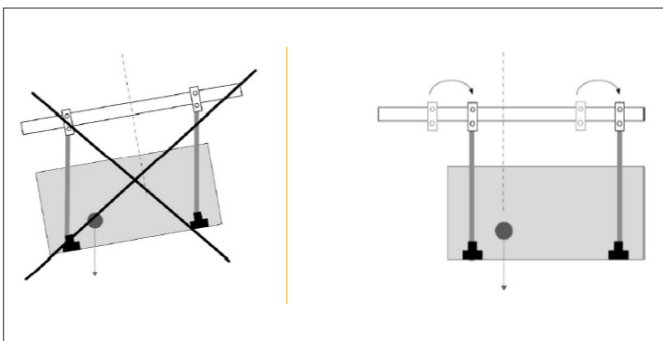

Gradually bring the lifting belts

Before starting the handling, make sure that the unit is stable.



6. Selecting the installation site

6.1 Positioning

WARNING

⚠ Installation must be in accordance with local regulations. If they do not exist, follow EN378 .

During positioning consider these elements:

- customer approval
- unit weight and bearing point capacity
- safe accessible position
- functional spaces
- spaces for the air intake/exhaust
- electrical connections
- max. distance allowed by the electrical connections
- water connections

The unit must be level

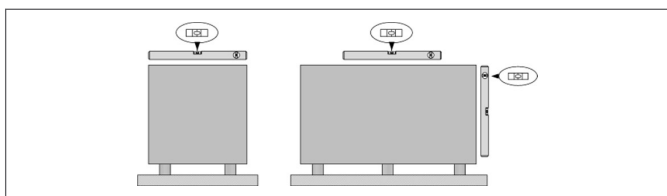

Do not go up to the surface

Not placing heavy objects

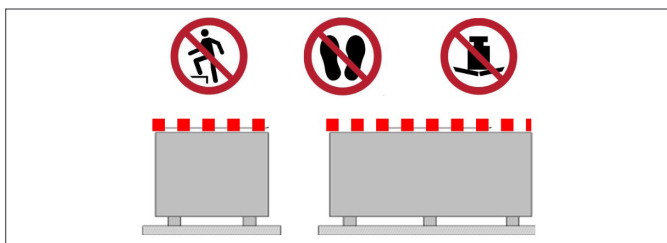

6.2 Functional spaces

Functional spaces are designed to:

- guarantee good unit operation
- carry out maintenance operations
- protect authorized operators and exposed people

⚠ Respect all functional spaces indicated in the TECHNICAL INFORMATION section.

6.3 Positioning

Units are designed to be installed:

- EXTERNAL
- in fixed positions

WARNING

⚠ Put the unit in a position where any leaking gas cannot enter buildings or stagnate in closed areas. In the latter case, observe the rules for machinery rooms (ventilation, leak detection, etc.).

Installation standards:

- install the unit raised from the ground
- bearing points aligned and leveled
- discharged condensation water must not cause harm/danger to people and property
- the accumulation of snow must not cause clogging of the coils
- avoid installations in places subject to flooding

Limit vibration transmission:

- use anti-vibration devices or neoprene strips on the unit support points
- install flexible joints on the hydraulic and aeraulic connections

The unit must not support the weight of channels, pipes, etc.

Protect the unit with suitable fence in order to avoid access to unauthorised personnel (children, vandals, etc.)

A correct circulation of the air is mandatory to guarantee the good unit operating..

Avoid therefore:

- obstacles to the airflow
- exchange difficulties
- leaves or other foreign bodies that can obstruct the exchange batteries
- winds that hinder or favour the airflow
- heat or pollution sources close to the unit (chimneys, extractors etc)
- stratification (cold air that stagnates at the bottom)
- recirculation (expelled air that is sucked in again)
- positioning below the level of the threshold, close to very high walls, attics or in angles that could give rise to stratification or recirculation phenomenons.

Ignoring the previous indications could:

- energy efficiency decrease
- alarm lockout due to HIGH PRESSURE (in summer) or LOW PRESSURE (in winter)
- infiltrations of water in the unit and in the aeraulic system and relative entrainment



Concrete floor

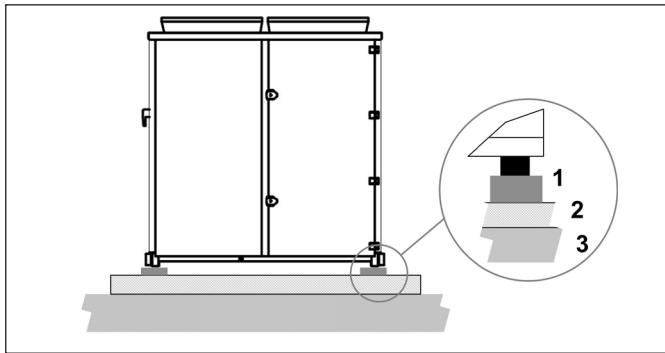

- 1 2 cm thick neoprene strips
- 2 concrete floor
- 3 floor

Steel structure

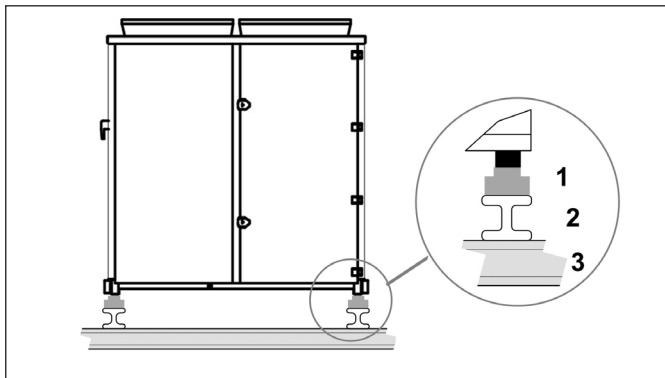

- 1 2 cm thick neoprene strips
- 2 concrete floor
- 3 floor

CBK, CBK-G, CCK-REVO configurations only

Avoid the accumulations of snow and ice in front of the exhaust air outlet.

Avoid the accumulations of snow and ice in front of the exhaust air outlet.

The most common contaminants for which the filter is designed, are:

- air pollution by PM10, PM 2,5 and PM1

Contaminants that can be filtered:

- dry smokes
- powder (up to 0,3 microns)
- smoke electrostatically charged

CONTAMINANTS THAT CAN NOT BE FILTERED:

- ⚠ water vapors also in low concentration
- ⚠ oil vapors

- ⚠ large amounts of dust
- ⚠ metal shavings, iron filing dusts and waste generally
- ⚠ Gas

ABSOLUTELY TO AVOID:

- ⚠ metal dusts also fine
- ⚠ fumes produced by combustion of organic and not materials (wood, coal, gasoline, etc.)

CBK, CBK-G, CCK-REVO only

Avoid snow accumulating

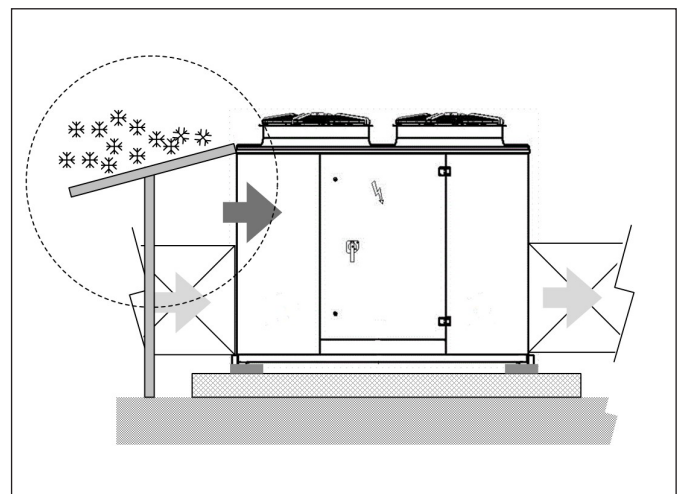
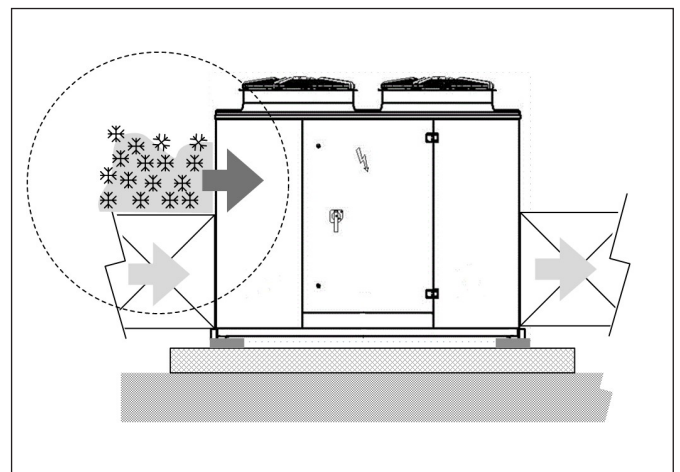



6.4 External air hood

CBK, CBK-G, CCK-REVO configurations

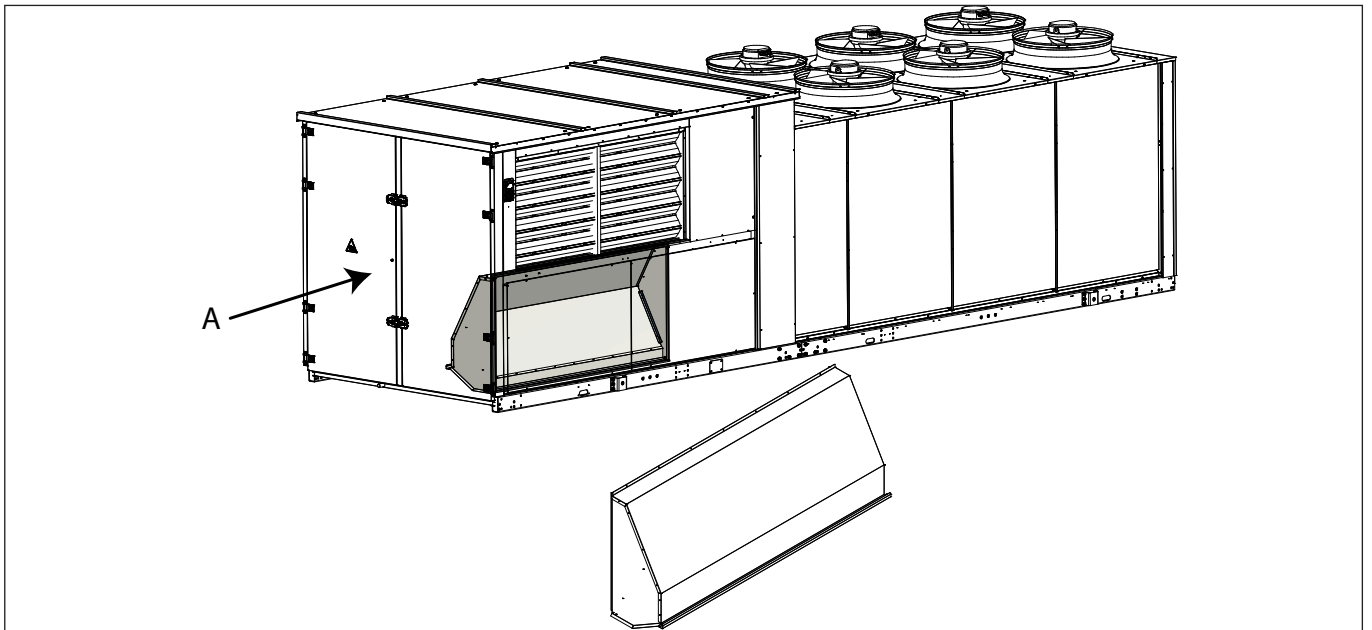

Open panel A, inside there is the hood and the fixing screws.

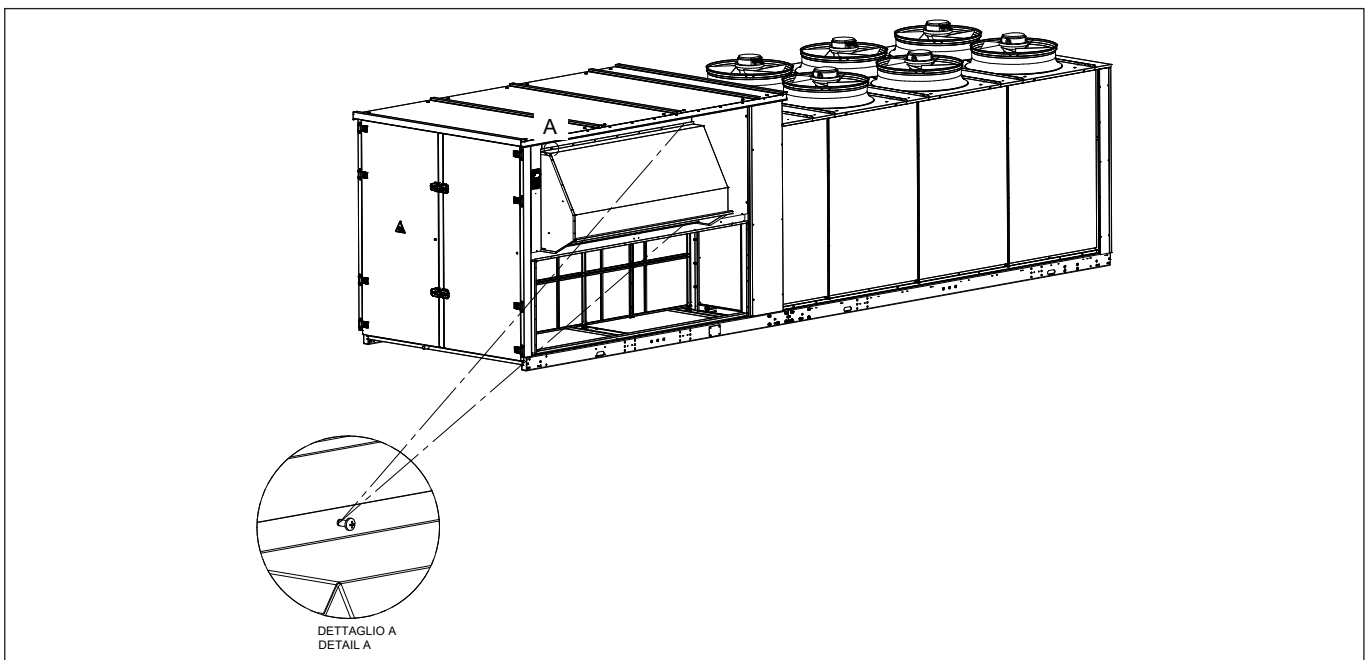

Secure the hood with screws



6.5 Gas heating module

Option

Burner with low pollutant emissions (NO_x below 80 mg/kWh), in line with Class 5 of the EN 676 European standard is supplied with a gas increase control for methane or LPG.

The heating module with burner includes:

- hot air generator powered with methane
- kit for transformation of power with liquefied petroleum gas (LPG)
- kit of steel chimney for exhaust fumes
- all the control and safety devices

- ⚠ **The component requires gas supply (gas connections to be made by the Customer).**
- ⚠ **The location of the unit and the fume drain mode must comply with laws and standards in force in the Country of use.**
- ⚠ **The Customer may choose the flue chimney.**
- ⚠ **The Customer is responsible for mounting the chimney kit during installation.**
- ⚠ **Based on the specific installation requirements, the length of the chimney can be increased with suitable joints and fittings (not supplied by Clivet).**

Gas connection

- Read the gas heating module manual.
- Connection must be carried out by qualified personnel.
- use certified components and comply with the local standards in force
- install on the gas connection: tap, large section filter and anti-vibration joint
- check the supply pressure is correct and stable, in particular where more uses are inserted on the same line.

System maintenance booklet

- It must be kept in the place of installation of the unit
- It must be filled-in upon commissioning
- It must be updated with the results of the periodical checks, of the routine and extraordinary maintenance interventions.

Interventions

For start-up, ordinary and extraordinary maintenance of the gas module, contact the local technical assistance of the manufacturer of the gas module.

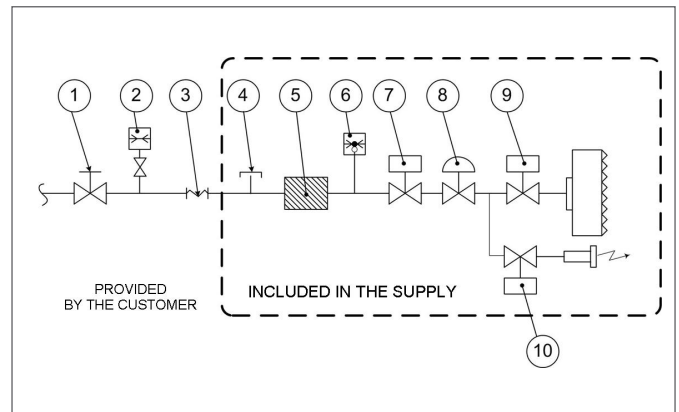

- 1 Gas cock
- 2 Gas filter (large section)
- 3 Anti-vibration joint
- 4 Gas filter (small section)
- 5 Safet gas solenoid valve
- 6 Pressure stabiliser
- 7 Main gas burner solenoid valve
- 8 Pilot burner gas solenoid valve

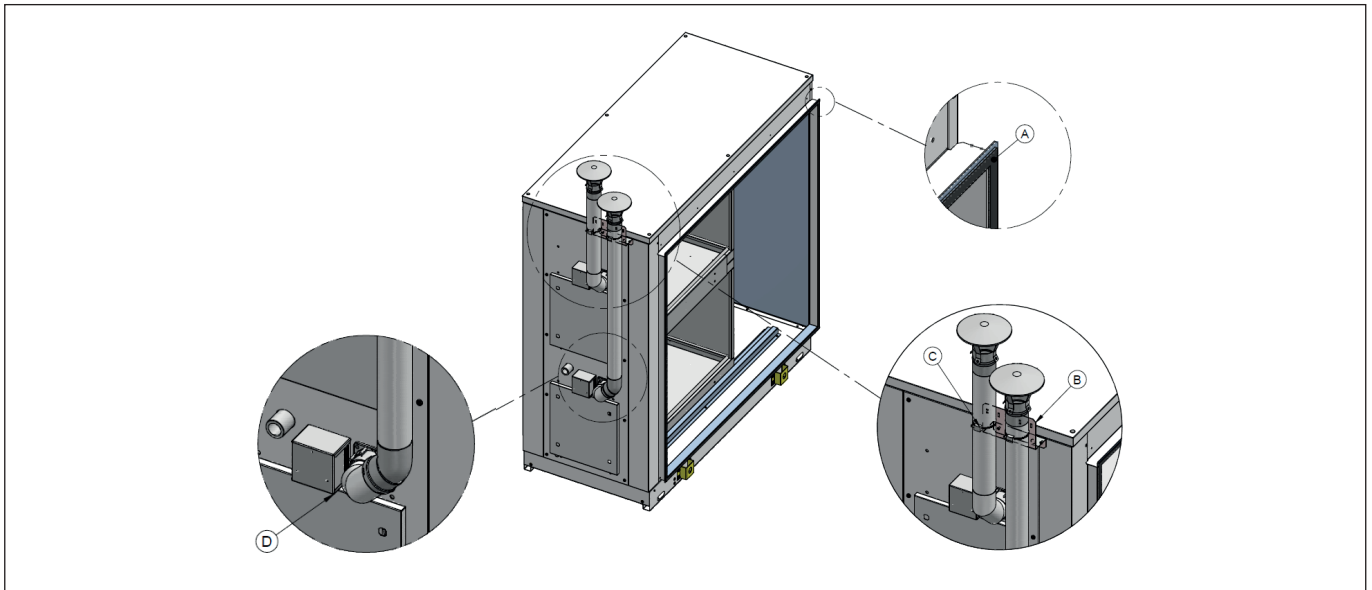

- A** Apply the flat adhesive gasket 15x5 on the Gas Module flange perimeter to guarantee the absence of air bypass.
- B** Fix with screws the flue supporting bracket to the GM frontal panel
- C** Fix the extensions with clamps to the flue supporting bracket
- D** Fix the suction terminals in ambient and the fuel components (curves, extensions, terminals) by the corresponding gaskets

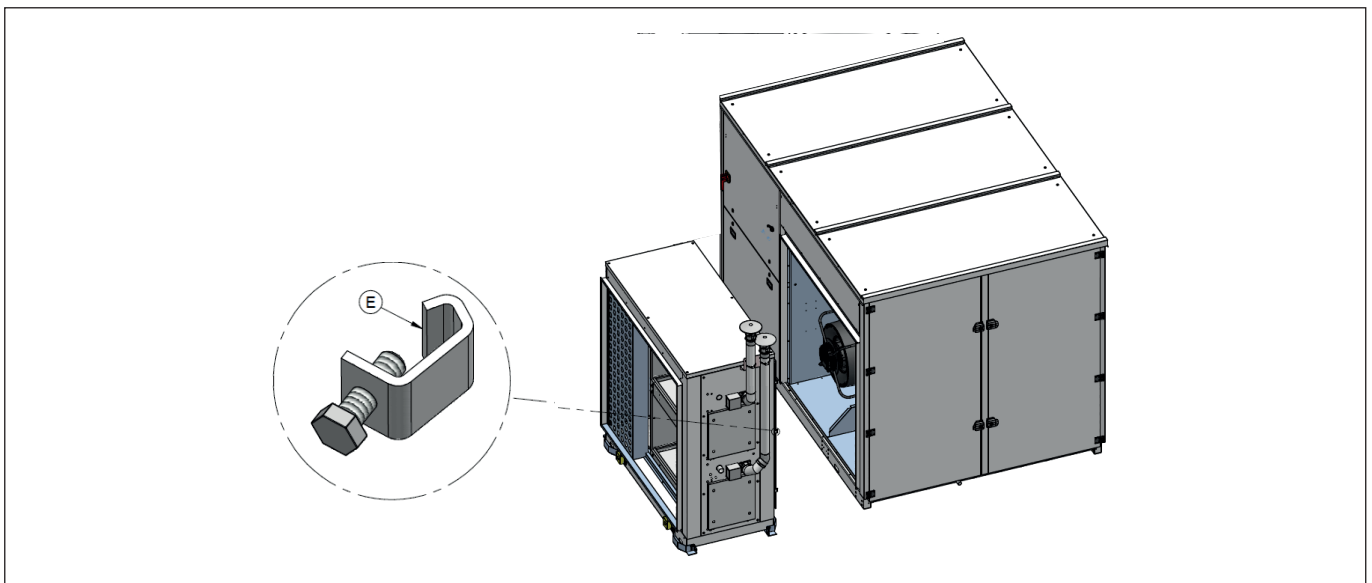

- 1** remove the unit supply flange closing.
- 2** approach the unit to the Gas Module.
- 3** match the supply flanges by means of the supplied terminals.
- 4** tighten screws
- 5** guarantee the absence of air bypass



Connections performed by customer

For a correct reading of the flow temperature, install the BT2-TC flow probe at 300cm from the gas module, in the case of a straight section of the duct, or at least 50 cm after the first curve, so that the air temperature is mixed properly.

Install the probe inside a plastic or metal tube to support, repair and ensure safety from bad weather or during maintenance

Inside the treatment area and the gas module there are the interfacing cables between the unit and the gas module (detail A)

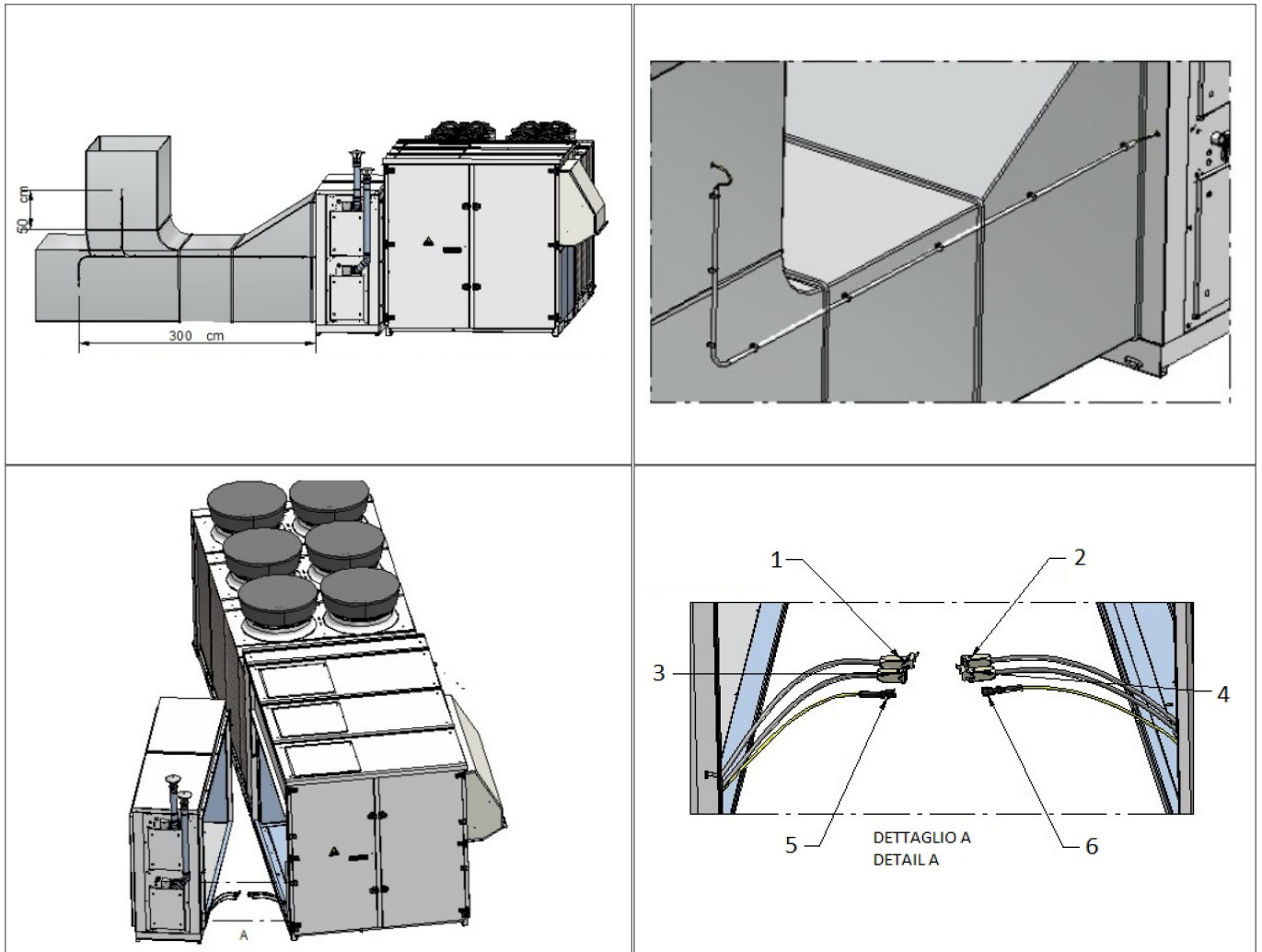

- 1 Gas module connection cable 1 CGASP
- 2 Gas module connection cable 1 CGASP
- 3 Gas module connection cable 2 CGASP
- 4 Gas module connection cable 2 CGASP
- 5 Delivery probe BT2 or TC
- 6 Delivery probe BT2 or TC



Gas use features

Description		82kW		100kW		130kW		164kW		200kW		300kW	
		min	max	min	max	min	max	min	max	min	max	min	max
Rated heating capacity	kW	16,4	82,0	21,0	100,0	12,4	130,0	16,4	164,0	21,0	200,0	21,0	300,0
Efficiency Hi (P.C.I.)	%	108,4	97,6	108,6	97,2	108,1	96,8	108,4	97,6	108,6	97,2	108,6	97,2
Efficiency Hs (P.C.S.)	%	97,6	87,9	97,8	87,5	97,4	87,2	97,6	87,9	97,8	87,5	97,8	87,5
Max condensation produced	l/h	3,3		2,7		4,2		6,6		5,4		8,1	
Carbon monoxide CO (0% di O ₂)	ppm	<5		<5		<5		<5		<5		<5	
Nitrogen oxides - NOx (0% di O ₂)		41 mg / kWh 23 ppm		39 mg / kWh 22 ppm		39 mg / kWh 23 ppm		41 mg / kWh 23 ppm		39 mg / kWh 22 ppm		39 mg / kWh 22 ppm	
Available flue pressure	Pa	120		120		120		120		120		120	
Gas connection diameter	GAS	UNI ISO 228/1 - G 3/4"		UNI ISO 228/1 - G 3/4"		UNI ISO 228/1 - G 1 1/2"		UNI ISO 228/1 - G 1 1/2"		UNI ISO 228/1 - G 1 1/2"		UNI ISO 228/1 - 1xG 1 1/2" e 1xG 3/4"	
Flue pipe diameter	mm	80		80		2 x 80		2 x 80		2 x 80		3 x 80	
Seasonal space heating energy efficiency [EU Reg./2281/2016] [η _s , h]	%	93,2		93,1		93,9		94		94		94,2	
Emission efficiency [EU Reg./2281/2016] [η _s flow]	%	97,1		97,0		98,1		97,9		97,9		98,1	
Power supply pressure (for gas G20)	mbar												
Gas consumption @15°C - 1013 mbar (for G20 gas)	m ³ /h	1,74	8,68	2,22	10,58	2,62	13,76	3,48	17,36	4,44	21,16	6,66	31,74



6.6 UV-C lamps

Option

WARNING

- ⚠ **Direct radiation device: causes eye irritation and skin rashes.**
- ⚠ **Any maintenance operation must be carried out with the lamps off.**

UV-C lamps use ultraviolet radiation to purify the air from the development of bacteria, molds, fungi and viruses.

The bactericidal and virucidal action is achieved with low pressure mercury lamps through direct radiation of the air flow with rays of a wavelength of 254 nm.

The option is installed in a separate module, external to the unit, with a dedicated electrical panel and separate power supply and is activated by the machine logic when the supply fans are running.

For the connection, see the wiring diagram.

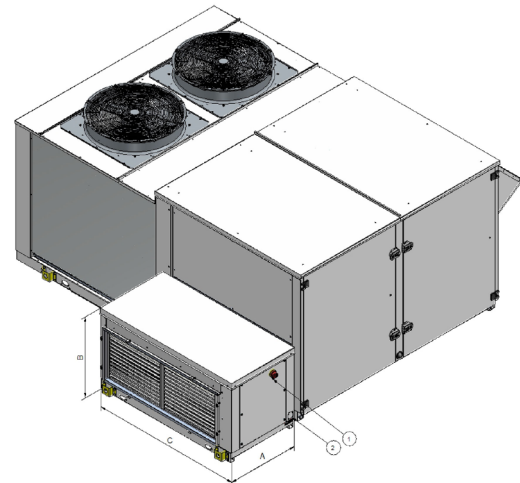

Size	A (mm)	B (mm)	C (mm)	FLI (kW)	FLA (A)
60.4	1095	1206	2508	600	2,65
70.4	1095	1206	2508	600	2,65
80.4	1095	1206	2508	600	2,65
90.4	1095	1204	3096	900	3,95
100.4	1095	1204	3096	900	3,95
120.4	1095	1204	3096	900	3,95



7. Water connections

Condensate drain

The condensate must be disposed in order to avoid damages to people and things.

- Unit discharge fitting: the connection must not transmit mechanical stresses and must be performed taking care not to damage the unit discharge fitting.
- The connection between the attachment and the siphon must be hermetically sealed (A)

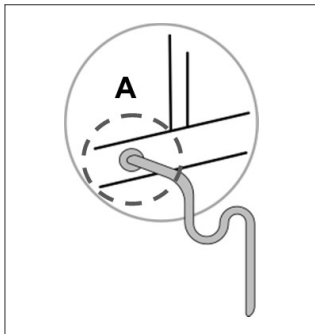

- The piping must have adequate slope to allow out flow.
- Anchor the ducting with an adequate number of supports.. Otherwise are generated duct failures and air locks that prevent the runoff.
- Insulate the duct and the siphon to avoid the condensate drippings.
- Connect the condensate discharge to a sewerage drainage network.
- DO NOT use white water or drainage networks to avoid the aspiration of odours in the case of evaporation of water contained in the siphon.
- Check at the end of the work, the regular condensate runoff pouring some water in the tray.

The maximum vacuum in the suction chamber of the treatment fan must not exceed 700 Pa.

In the event that the system provides for a major depression, the condensate drain must be carried out in compliance with the sizing criteria indicated below.

Provide a siphon that, eliminating the negative pressure caused by the fan, prevents the air intake from the discharge duct.

Siphon height calculation

$$T = 2P$$

$$S = T/2$$

P is the pressure determined by the fan in correspondence of the condensate collection bowl (approx. 1 mm = 9.81 Pa)

Example :

$$P = 300 \text{ Pa} = 30 \text{ mm}$$

$$T = 2P = 60 \text{ mm}$$

$$S = T/2 = 30 \text{ mm}$$

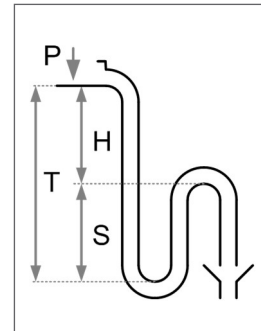

7.1 Condensation in winter operation

When a heat pump is running it produces a considerable amount of water due to the defrosting cycles of the external coil.

The condensate must be disposed in order to avoid damages to people and things.

7.2 Risk of freezing

Prevent the risk of freeze if the unit, drain or plumbing connections can be subject to temperatures close to 0°C.

- isolate the piping
- protect the piping with heating cables laid underneath the insulation



7.3 Immersed electrodes humidifier

Option

The humidification function is only enabled with the unit in heating mode.

Connexion humidificateur: 1" F

Supply water

The humidifier must be supplied with mains water having the following features:

- pressure between 0.1 and 0.8 Mpa (1 – 8 bar)
- temperature between 1 and 40°C

Do not use:

- water treated with softeners: it can corrode the electrodes and form foam with possible faults/malfunctionings
- pit, industrial or potentially polluted (chemically or bacteriologically) water
- disinfectants or anti-corrosive substances mixed with water, as potentially irritating

Supplying the humidifier with water treated with reverse osmosis filtering system gives the following advantages:

- reduces limescale deposits
- reduces energy consumptions
- reduces maintenance costs
- increases humidifier duration

Check that the filter guarantees a water flow rate higher than the flow rate of the installed humidifier.

Limit values for the supply water

Respect the limits indicated in the table

No relation can be demonstrated between water hardness and conductivity.

Limit values for the supply water	conductivity		medium-low		medium-high	
			min	max	min	max
Hydrogen ions	pH		7	8,5	7	8,5
Specific conductivity at 20°C		µS/cm	125	500	300	1250
Total dissolved solids	TDS	mg/l	(1)	(1)	(1)	(1)
Dry residue at 180°C	R ₁₈₀	mg/l	(1)	(1)	(1)	(1)
Total hardness	TH	mg/l CaCO ₃	50 (2)	250	100 (2)	400
Temporary hardness		mg/l CaCO ₃	30 (3)	150	60 (3)	300
Iron + Manganese		mg/l Fe+Mn	0	0,2	0	0,2
Chlorides		ppm Cl	0	20	0	30
Silica		mg/l SiO ₂	0	20	0	20
Residual chlorine		mg/l Cl-	0	0,2	0	0,2
Calcium sulphate		mg/l CaSO ₄	0	60	0	100
Metallic impurities		mg/l	0	0	0	0
Solvents, diluents, soaps, lubricants		mg/l	0	0	0	0

1 Values depending on specific conductivity; in general:

$$TDS \cong 0,93 * \sigma_{20}; R_{180} \cong 0,65 * \sigma_{20}$$

2 not lower than 200% of the chloride content in mg/l of Cl⁻

3 not lower than 300% of the chloride content in mg/l of Cl⁻

Drainage water

It can reach a temperature of 100°C.

It contains the same substances of the supply water but in higher concentration.

As it is not toxic, it can be disposed of with white waters



7.4 Heating coil

Option

Max. operating pressure = 10 bar

Water flow modulation valve already mounted and wired on the machine

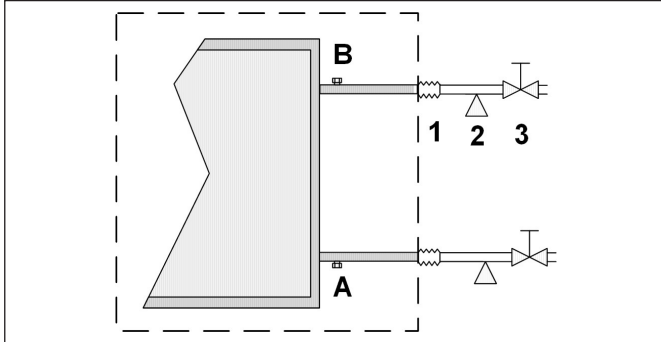

- A** drain cock
- B** vent valve

Provided by the customer:

- 1** anti-vibration devices
- 2** piping supports
- 3** Shut-off valves



8. Aeraulic connections

The dimensioning and correct execution of the aeraulic connections are fundamental to guarantee good unit operation and adequate level of silence in the room.

When designing and manufacturing the ducting, consider **LOAD LOSSES, AIR FLOW AND SPEED** that must be consistent with the unit features.

Particularly consider that load losses higher than the unit useful prevalence, lead to reduction in flow rate, with consequent unit blocks.

- the weight of the channels must not burden on the connection flanges
- place anti-vibration joints between channels and unit
- connection to the flanges and between the various sections of the channels must guarantee air seal, avoiding dispersions penalising the overall efficiency of the system
- limit the load losses by optimising the path, the type and number of bends and junctions
- use wide bends evaluating the opportunity of equipping them with deflectors (in particular with high air speed or bends with reduced radius)

8.1 Treated air channelling

The internal surface of the channel must be smooth, enable its washing and must not contaminate the air.

Thermally isolate the channels, flanges and silencers to avoid energy losses and forming of condensation.

DIFFUSERS INLETS GRILLES

A correct diffusion of the air in the room is determining for the level of comfort and correct operation of the unit.

When choosing and positioning the grilles, inlets and diffusers, avoid:

- excessive air speed
- forming of stagnant and stratification areas
- cold air delivery in room
- forming of localised currents (also due to uneven distribution of air)
- excessive room temperature variations, vertically and horizontally
- short circuits of the supply air towards the return air

For sound comfort, consider that:

- the air diffusers must be chosen verifying the sound power generated at nominal flow rate conditions
- the cut-off to diffusers must be carried out with flexible elements
- the return grilles must be widely dimensioned

Isolate the channels

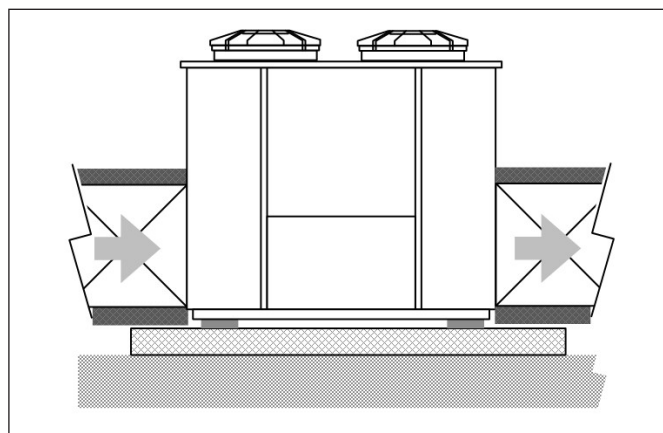

Isolate the flanges

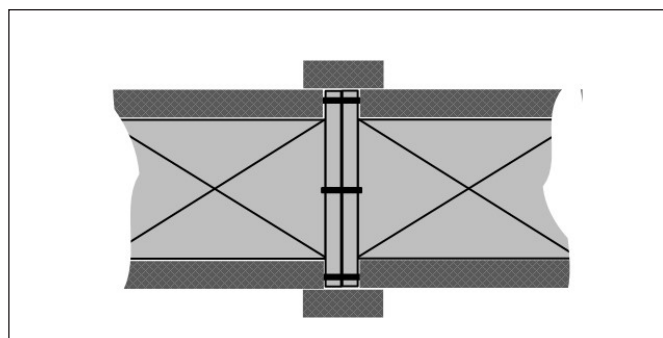



9. Electrical connections

The characteristics of the electrical lines must be determined by specialized personnel able to design electrical installations; moreover, the lines must be in conformity with regulations in force.

The protection devices of the unit power line must be able to stop the presumed short circuit current, whose value must be determined in function of system features.

The power cables and the protection cable section must be defined in accordance with the characteristics of the protections adopted.

All electrical operations should be performed by trained personnel having the necessary requirements by the regulations in force and being informed about the risks relevant to these activities.

Operate in compliance with safety regulations in force.

9.1 Electrical data

The serial number label reports the unit specific electrical data, included any electrical accessories.

The electrical data indicated in the technical bulletin and in the manual refer to the standard unit, accessories excluded.

The matriculation plate shows the indications foreseen by the standards, in particular:

Tensione

F.L.A.: full load ampere, absorbed current at maximum admitted conditions

F.L.I.: full load input, full load power input at max. admissible condition

Electrical wiring diagram Nr

9.2 Connections

- 1 Refer to the unit electrical diagram (the number of the diagram is shown on the serial number label).
- 2 verify that the network has characteristics conforming to the data shown on the serial number label.
- 3 Before starting work, verify that the sectioning device at the start of the unit power line is open, blocked and equipped with cartel warning.
- 4 Primarily you have to realize the earthing connection.
- 5 Shelter the cables using adequate measure fairleads.
- 6 Prevent dust, insects or rodents from entering the electrical panel as they can damage components and cables.
- 7 Prevent noise from escaping from the compressor compartment; seal any openings made.
- 8 Fix the cables: if vacated may be subject to tearing.
- 9 The cable must not touch the compressor and the refrigerant piping (they reach high temperatures).

10 Do not drill holes in the electrical panel.

11 Alternatively, restore the IP rating with watertight systems.

12 Before power the unit, make sure that all the protections that were removed during the electrical connection work have been restored.

9.3 Power supply network requirements

- 1 The short circuit capacity of the line must be less than 15 kA
- 2 The units can only be connected to TN, TT distribution systems
- 3 Voltage 400-3-50 +/-10%
- 4 Phase unbalance < 2%
- 5 Harmonic distortion less than 12% (THDv<12%)
- 6 Voltage interruptions lasting no longer than 3ms and with at least 1 s between each one
- 7 Voltage dips not exceeding 20% of the RMS value, lasting no longer than a single period (50Hz) and with at least 1 s between each dip.
- 8 Earth cable as specified in the table:

Cross-section of the line conductors (mm ²)	Minimum cross-section of the protective conductor (PE) (mm ²)
$S \leq 16$	S
$16 < S \leq 35$	16
$S > 35$	S/2

9.4 Signals / data lines

Do not overpass the maximum power allowed, which varies, according to the type of signal.

Lay the cables far from power cables or cables having a different tension and that are able to emit electromagnetic disturbances.

Do not lay the cable near devices which can generate electromagnetic interferences.

Do not lay the cables parallel to other cables; cable crossings are possible, only if laid at 90°.

The type of cable must be suitable for serial data communication.

A 3-pole shielded bus cable is required *.

The data transmission bus cable must be verified according to the type of installation in which it will be placed and must comply with local standards.



The bus cable must comply with non-prescribed local electrical standards (e.g. insulation, voltages, flame propagation, etc.).

The cable shield must be grounded at a single point free from disturbances*.

In order to ensure correct communication, the earth connection of the shield can also be configured differently depending on the area and the types of interference.

Allowed topology: daisy-chain (enter and exit)*.

Other topologies such as "ring" or "star" are not allowed*.

Do not use cable lugs on the communication bus.

* (if using RS-485 protocol)

9.5 Power input

Fix the cables: if vacated may be subject to tearing.

The cable must not touch the compressor and the refrigerant piping (they reach high temperatures).

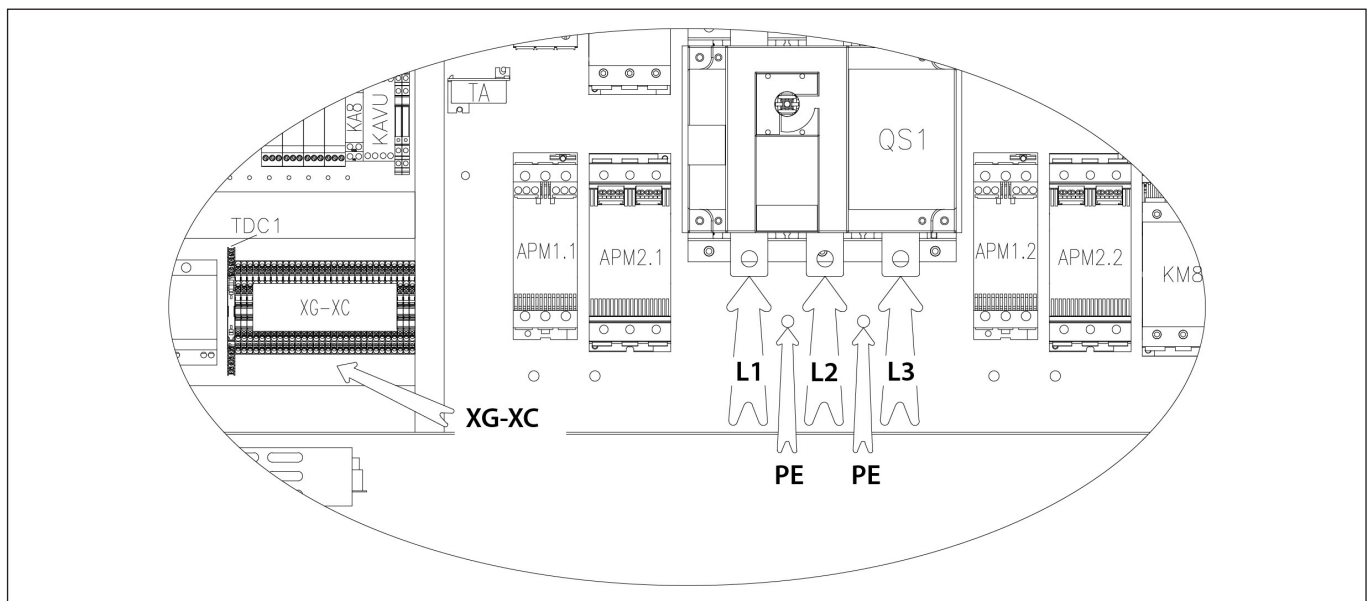

XG-XC

Terminal block connections by the customer



Power supply cables section

Size	60.4	70.4	80.4	90.4	100.4	120.4
Min. cable section Cu (mm ²)	1 x 95	1 x 150	1 x 150	1 x 240	1 x 240	1 x 240
Max. cable section Cu (mm ²)	1 x 185	1 x 240	1 x 240	1 x 240	1 x 240	1 x 240
Max. bar Cu width (mm)	32.0	32.0	32.0	40.0	40.0	40.0
Tightening torque (Nm)	20.0	20.0	20.0	20.0	20.0	20.0

Connections performer by customer

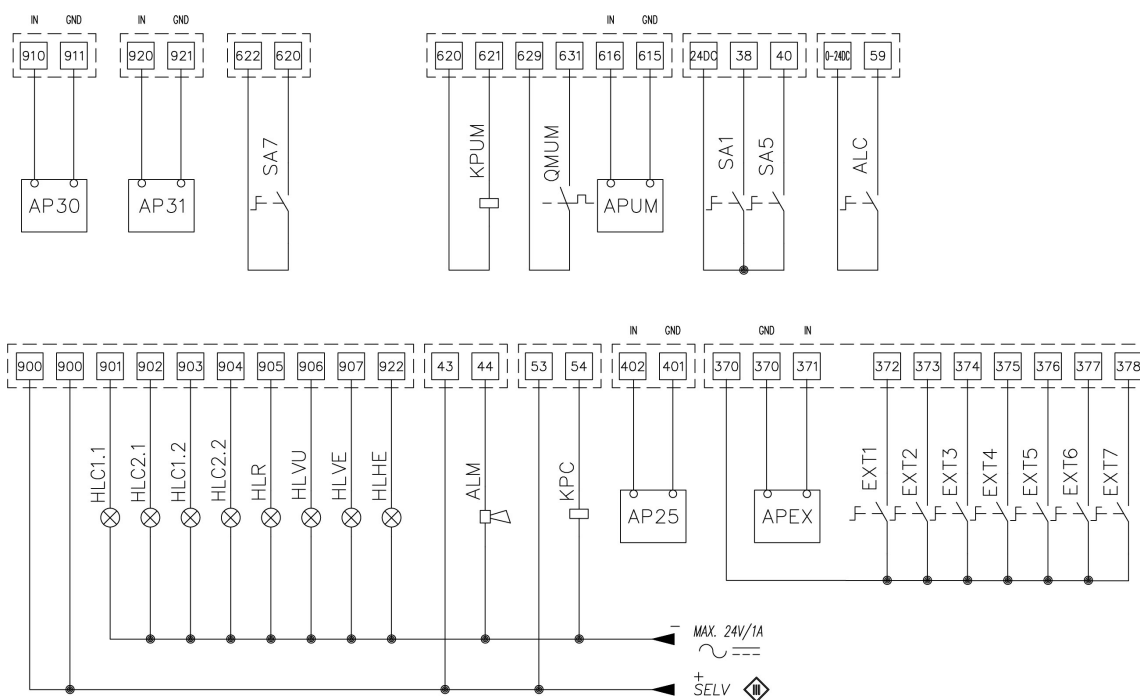

ALC	Free contact from signalling system of fire alarm	SA7	Enabling selector to the umidifier manual discharge
ALM	Cumulative block signal	KPC	Pump/circulator control of the integration coil
HLC 1.1...2.2	Compressor status light	EXT1...7	Potential-free contact of room extractor
HLR	Electrical panel heater alarm light	AP25	Modulating extraction module with 0-10V signal
HLHE	Heat pump operating status light	AP30	0-10V signal for supply and exhaust air flow modulation
HLVE	Return and/or extraction fan status light	AP31	Can be fitted with remote CO ₂ probe
HLVU	Supply fan status light	KPUM	Humidifier power contactor
SA1	Remote ON/OFF selector	QMUM	Magnetothermic circuit breaker to protect the humidifier
SA5	Remote summer/winter selector switch	APUM	0...10V humidifier signal

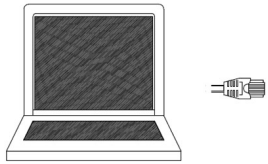
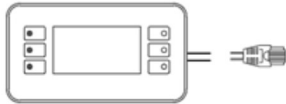
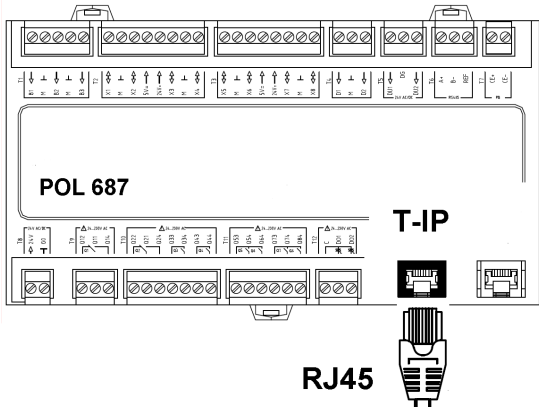
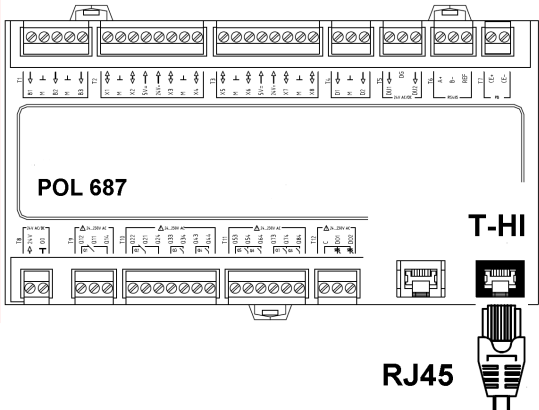

P.C. - not supplied	Optional keypad
	
RJ45 : collegamento standard	Spostare RJ45 da T-IP a T-HI
	

Configure P.C.

- 1 connect P.C. and main module with LAN cable
- 2 check in the taskbar that the connection is active
- 3 Open Control panel and select Network and sharing center
- 4 Select Modify board setting
- 5 Select Local area connection (LAN)
- 6 Select Internet protocol version 4 (TCP) IPV4 and enter Property
- 7 Set the IP address 192.168.1.100
- 8 Set Subnet mask as 255.255.255.0
- 9 confirm (OK)
- 10 Enter Start (Windows button).
- 11 Write the command cmd and enter/do it
- 12 Write and run the command Ping 192.168.1.42
- 13 if will appear dawn an answer string, the connection is ok
- 14 enter the browser (Chrome, Firefox ecc)
- 15 Write and run the command `http://192.168.1.42`
- 16 Userid = WEB
- 17 Password = SBTAdmin!



9.6 Remote control with user interface POL822

Distance up to 350 mt

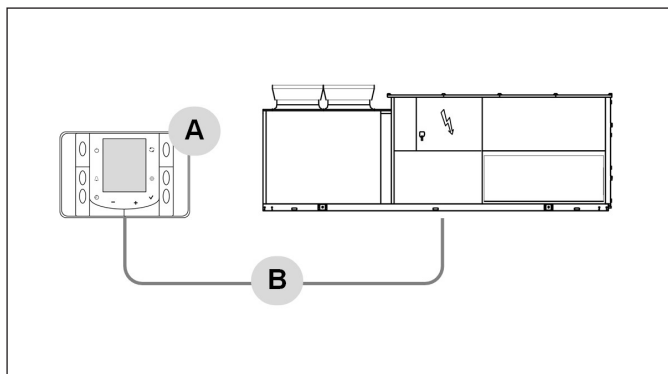

Distance up to 700 mt

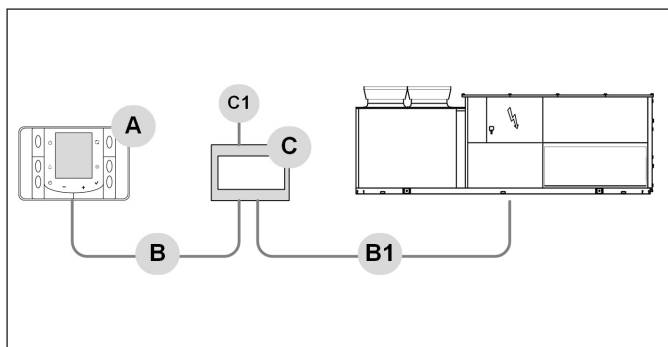

- A user interface
- B = B1 KNX bus, max 350 mt
twisted pair with shield, \varnothing 0,8 mm
EIB/KNX cable marking recommended
- C power supply unit N125/11 5WG1 125-1AB11
- C1 AC 120...230 V, 50...60 Hz

Connections

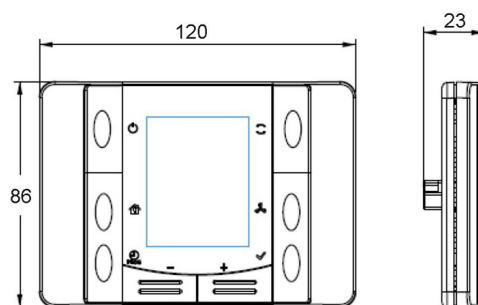
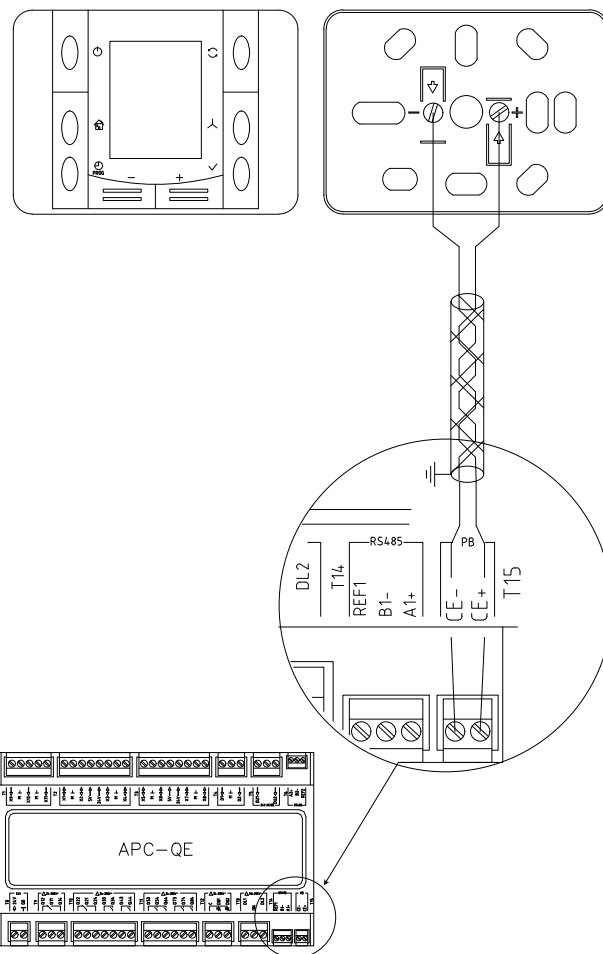



9.7 ModBUS

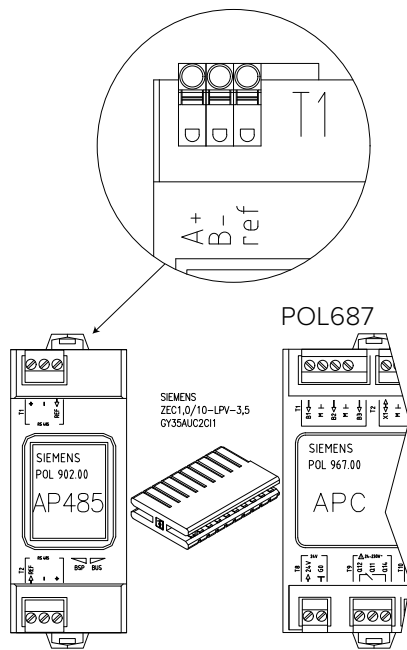

- Every RS485 serial line must be set up using the 'In/ Out' bus system. Other types of networks are not allowed.

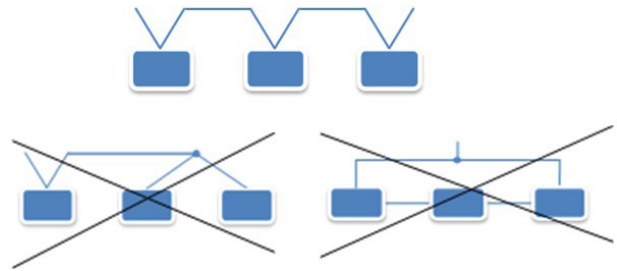

- The difference in potential between the earth of the two RS485 devices that the cable shielding needs to be connected to must be lower than 7 V
- Suitable arresters must be set up to protect the serial lines from the effects of the atmospheric discharges
- A 120 ohm resistance must be located on the end of the serial line. Alternatively, when the last serial board is equipped with an internal terminator, it must be enabled using the specific parameter (installer-level password-protected menu)
- The cable must have insulation features and non-flame propagation in accordance with applicable regulations
- The RS485 serial line must be kept as far away as possible from sources of electromagnetic interference

LED BSP communication with APC module

green	communication ok
yellow	software ok but communication with APC down
red	flashing : software error
	fixed : hardware error

LED BUS communication with MODBUS

green	communication ok
yellow	startup / channel not communicating
red	communication down

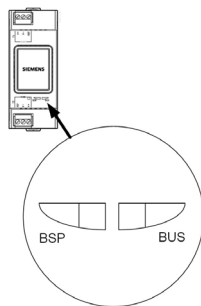

Cable MODBUS, requirements

Couple of conductors twisted and shielded

Section of conductor 0.22mm²...0.35mm²

Nominal capacity between conductors < 50 pF/m

nominal impedance 120 Ω

Recommended cable BELDEN 3106A

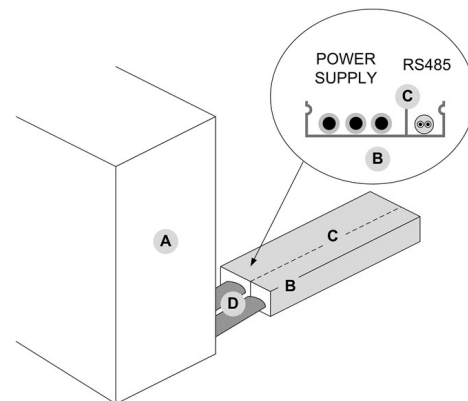

- A** Unit
- B** metal conduit
- C** metal septums
- D** metal-lined sheath (sleeve)



9.8 BACnet IP

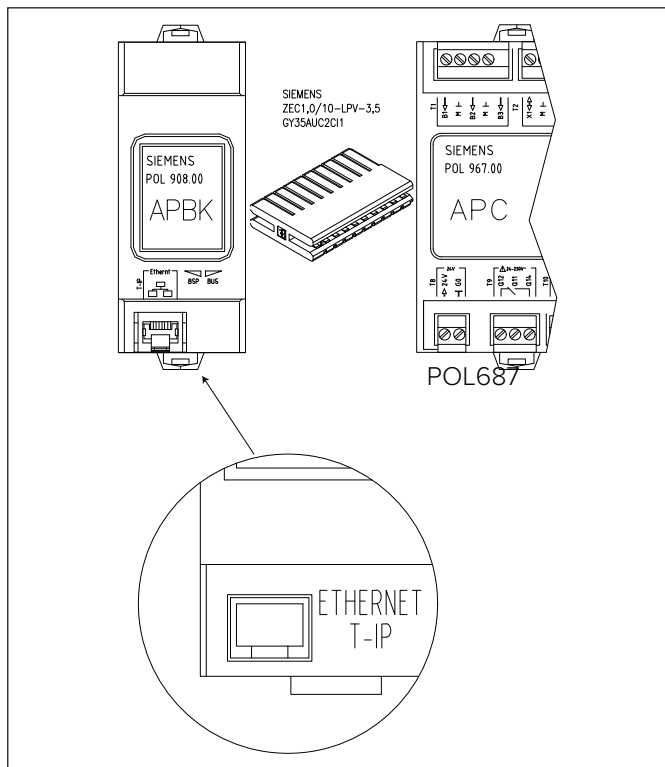

- LED BSP communication with APC module**
- green communication ok
 - yellow software ok but communication with APC down
 - red flashing : software error
 - fixed : hardware error
- LED BUS communication with BACNET**
- green ready for communication
 - yellow startup
 - red BACnet server down
 - restart after 3 sec.

9.9 LONWORKS

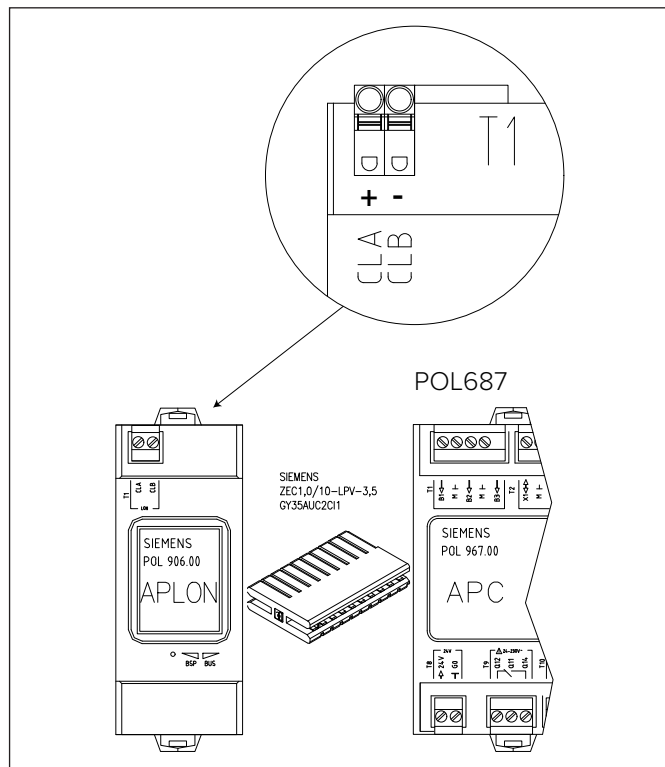

- LED BSP communication with APC module**
- green communication ok
 - yellow software ok but communication with APC down
 - red flashing : software error
 - fixed : hardware error
- LED BUS communication with LONWORK**
- green ready for communication
 - yellow startup
 - flashing: communicating not possible
 - red communication down

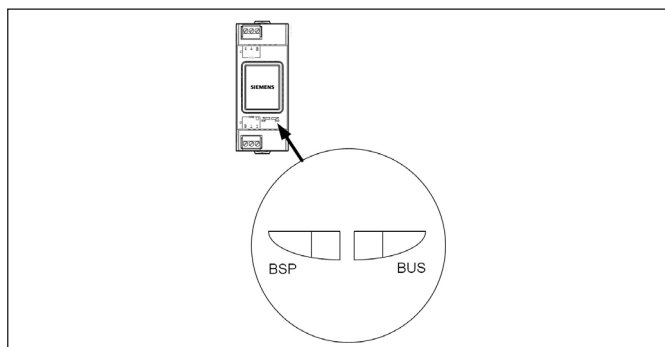

LONWORK CABLE TYPES

Echelon allows three cable types for channel type TP/ FT-10, including the Category 5 network cable used commonly in building automation and control (TIA 568A Cat-5).



9.10 BACnet MSTP

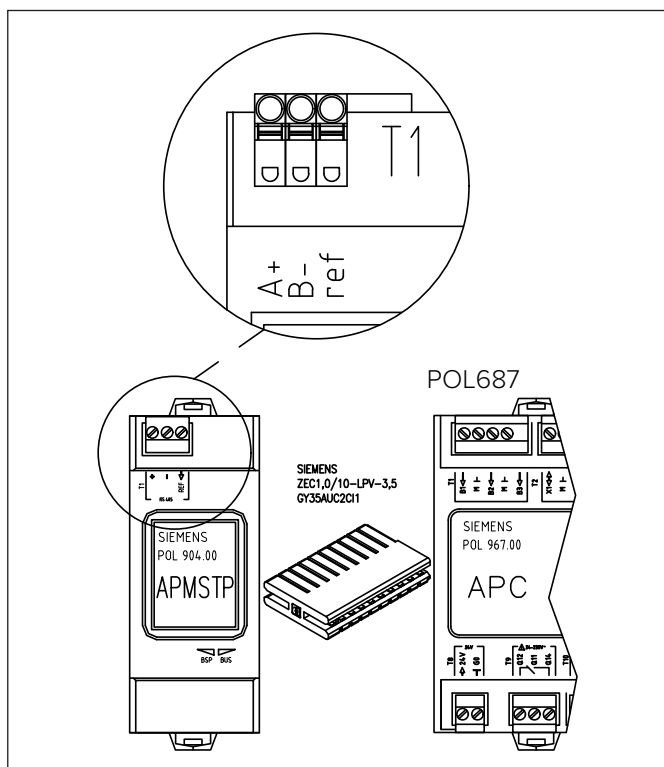

LED BSP communication with APC module

- green communication ok
- yellow software ok but communication with APC down
- red flashing : software error
- fixed : hardware error

LED BUS communication with BACNET

- green ready for communication
- yellow startup
- red BACnet server down
- restart after 3 sec.

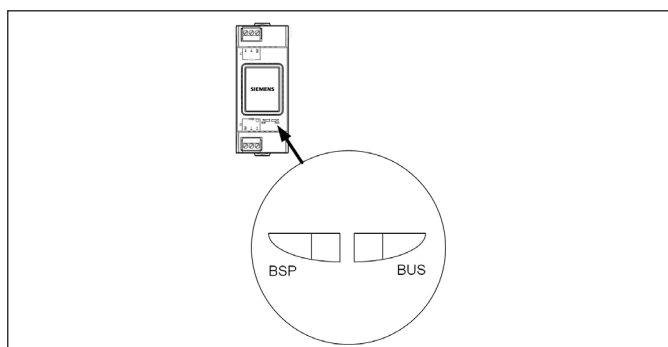



10. Start-up

The indicated operations must be carried out by qualified technicians and specifically trained on the product. Upon request, the after-sales assistance centres execute start-up.

The electrical, water connections and the other system works are by the installer.

Agree upon in advance the start-up data with the service centre.

Before checking, please verify the following:

- the unit should be installed properly and in conformity with this manual
- the electrical power supply line should be isolated at the beginning
- the unit isolator is open, locked and equipped with the suitable warning
- make sure no tension is present

 **After turning off the power, wait at least 5 minutes before accessing to the electrical panel or any other electrical component.**

 **Before accessing check with a multimeter that there are no residual stresses.**

NOTE

Refer to the Service Manual for detailed instructions

10.1 UV-C lamps

Option

WARNING

 **Direct radiation device: causes eye irritation and skin rashes.**

 **Any maintenance operation must be carried out with the lamps off.**





10.2 Start-up sequence

For details refer to the different manual sections.

	Unit OFF power supply
1	Secure access to the unit.
2	Functional spaces of the unit.
3	External and internal inspection of the unit to check that it is intact.
4	Unit installed according to the requirements on its anti-vibration devices.
5	The rainproof cover of the outdoor air intake is correctly installed. (Only for CBK / CBK-G and CCK-REVO units)
6	The external modules are installed according to the requirements on their anti-vibration devices. (Only for units equipped with gas burner, enthalpy wheel or UV-C lamp module).
7	The air filters are clean and installed correctly.
8	The unit is connected to the aeraulic system with anti-vibration joints.
9	The condensation water drain pipe has a siphon and is heated (in low temperature environment).
10	Visual inspection of the refrigerant circuit to rule out obvious leaks and/or oil stains.
11	Unit connected to power supply consistent with requirements.
12	The unit is properly earthed.
13	The phase sequence is correct (if not, an alarm occurs).
14	If present, the customer's BMS or external signals are correctly wired to the specified terminal.
15	The compressor casing heater must be powered for at least 8 hours before the service appointed by Clivet carries out start-up.
16	The aeraulic system is complete in all its parts.
17	Internal air distribution avoids air stratification and/or bypass between supply air and return air.
18	The user interface (HMI) of the unit is installed and wired correctly.
19	The sensors of the unit placed in the indoor environment are installed and wired correctly (option).



10.3 Start-up sequence

For details refer to the different manual sections.

Unit ON power supply	
1	Make sure that the compressor casing heaters have been powered for at least 8 hours before start-up.
2	Check that all the sensors on the unit are reading the correct and consistent value.
3	Check the correct operation of the unit's HMI.
4	Check and/or calibrate the air flow, starting the unit in FAV (ventilation only) mode
5	Calibrate the setpamb. (Only for CCK-REVO units)
6	Calibrate the minimum and maximum flow of outdoor air. (CBK-G units equipped with Enthalpy Wheel module)
7	Calibrate the minimum and maximum flow of exhaust air. (CBK-G units equipped with Enthalpy Wheel module)
8	Check whether the air conditions (outdoor and indoor T/R.H%/T/R.H) are within the operating range of the unit stated in the Technical Bulletin.
9	Ensure that there is enough thermal load within the treated environment to allow continuous operation of the unit, avoiding frequent compressor starts/stops.
10	Check each refrigerant circuit in a mode (heating or cooling) consistent with the air conditions. If permitted, test the unit in both operating modes.
11	Check the operating status of each refrigerant circuit during its operation.
12	Ensure that there is no air bypass between the inlet and outlet of the external exchanger.
13	Check the stability, within the permitted ranges, of the power supply voltage and electric consumption of each compressor when the unit is at full power (all compressors ON).
14	Ensure that there are no abnormal vibrations/noises on each circuit and/or compressor.
15	Test operation of the auxiliary elements (available only in heating mode). (Only for units with auxiliary elements)
16	Test the humidifier (only available in heating mode). (Only for units with humidifier)
17	In case of connection via BMS, check that the commands are written in the correct registers.
18	Set the logic of the fire alarm digital input.
19	Check correct operation of the analogue/digital inputs reserved for the customer.
21	Set the unit in accordance with the customer's requirements (setpoint, operating mode, scheduler, ECO etc.).



10.4 Refrigeration circuit

- 1 Check carefully the refrigerating circuit: the presence of oil stains can mean leakage caused by transportation, movements or other).

10.5 Water circuit

Only with options: humidifier - hot water coil and hot water coil for refrigerated cabinet recovery.

- 1 Before realizing the unit connection make sure that the hydraulic system has been cleaned up and the cleaning water has been drained.
- 2 Check that the water circuit has been filled and pressurized.
- 3 Check that the shut-off valves in the circuit are in the "OPEN" position.
- 4 Check that there isn't air in the circuit, if required, evacuate it using the air bleed valve placed in the system high points.
- 5 When using antifreeze solutions, make sure the glycol percentage is suitable for the type of use envisaged.

WARNING

- Neglecting the washing will lead to several filter cleaning interventions and at worst cases can cause damages to the exchangers and the other parts.**

10.6 Electric Circuit

Verify that the unit is connected to the ground plant.

Check the conductors are tightened as: the vibrations caused by handling and transport might cause these to come loose.

Connect the unit by closing the sectioning device, but leave it on OFF.

Check the voltage and line frequency values which must be within the limits: 400/3/50 +/- 10%

Check and adjust the phase balance as necessary: it must be lower than 2%

WARNING

- Working outside of these limits can cause irreversible damages and voids the warranty.**

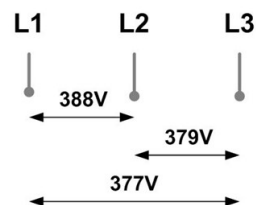

$$1) \quad \frac{388 + 379 + 377}{3} = 381 \text{ (A)}$$

$$2) \quad \text{MAX} - A = 388 - 381 = 7$$

$$3) \quad S = \frac{7}{A} \times 100 = 1,83 \text{ OK}$$

10.7 Compressor casing heater

Power the compressor oil heating resistors for at least 8 hours before starting the compressor itself:

- upon unit commissioning
 - after every prolonged stop period with unit not powered
- 1 Power the heaters: isolator switch on 1/ON and magnetothermic circuit breaker QMA 1/ON.
 - 2 Check electric absorption of the resistors to be sure they are working.
 - 3 Execute start only if the temperature of the compressor casing on the lower side is at least 10°C higher than the outdoor temperature.
 - 4 Do not start the compressor with carter oil not in temperatureTensioni



10.8 Fire alarm: configuration

- ⚠ The unit cannot be used as smoke extractor.
- ⚠ Any fire detection devices built-in the unit must be considered as an auxiliary safety system, and, accordingly, must not be a replacement for any fire detection devices in the room.

Complete unit shutdown

Unit CAK, CBK, CBK-G, CCK-REVO

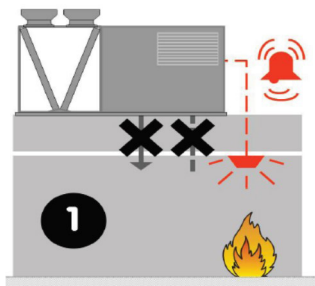

Space in overpressure

Unit CBK, CBK-G, CCK-REVO

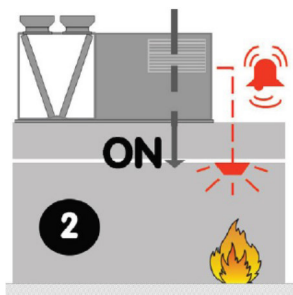

Space in negative pressure

CBK-G unit + enthalpy wheel module

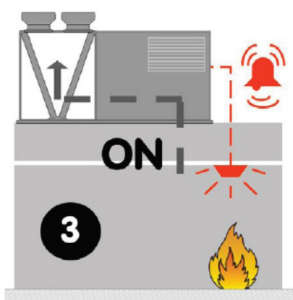

It is possible to configure the unit behaviour in presence of alarm signal.

Menu thermoregulator, P94 TypeFireMode:

- NEUTRAL = unit complete stop,
- DEPRESSURE = room in depression,
- PRESSURE = room pressurised

In presence of alarm:

- the compressors are switched off
- On-Off remote is disabled
- On-Off from keyboard is disabled

complete stop		supply fan	off
	*	ejection fan	off
		outdoor air shutter	closed
* room kept in depression		supply fan	off
	*	ejection fan	on
		outdoor air shutter	closed
room kept pressurised		supply fan	on
	*	ejection fan	off
		outdoor air shutter	open

* Only configuration CBK-G + enthalpy wheel or CCK-REVO

10.9 Start-up report

The measurements must be kept and made available during maintenance interventions.

10.10 2014/68/UE PED directive

DIRECTIVE 2014/68/UE PED gives instructions for installers, users and maintenance technicians as well.

Refer to local regulations; briefly and as an example, see the following:

Compulsory verification of the first installation:

- only for units assembled on the installer's building site (for ex. Condensing circuit + direct expansion unit)

Certification of setting in service:







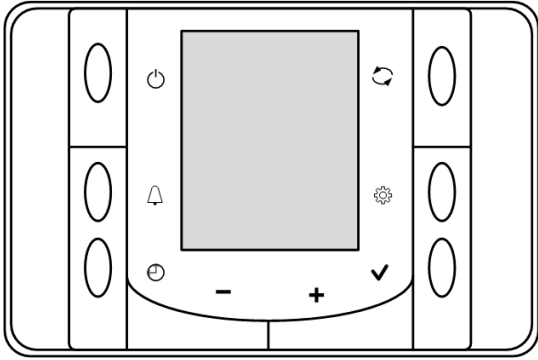

- for all the units

Periodical verifications:











- to be executed with the frequency indicated by the Manufacturer (see the "maintenance inspections" paragraph)



11. Control

Keypad	Function keys
	 change of status: OFF, ON, ECO, FAN
	 ALARMS menu access (if available)
	 set TIME and DATE set SCHEDULER (prolonged pressure)
	 to browse through the menus to set values
	 to browse through the menus to set values
	 access to the STATUS menu to confirm your selection
	 to access the PARAMETERS menu (password 0047) installer use KEYPAD LOCK menu (password 1000)
 HEAT - COOL mode change CLEAN function (prolonged pressure)	

Symbols

 ON / OFF OFF status. On the top field of the thermostat, the temperature and OFF indication are alternated every 2 seconds. When the status is OFF, changes to the SETPOINT and schedule are blocked.	 Humidifier / Dehumidifier mode The Humidifier mode is active (heating only) If flashing, it means the Dehumidifier mode is active (only in cooling)
 Automatic Mode: The temperature setpoint is in automatic mode. The user cannot change the setpoint value.	 Recirculation mode: The machine is in recirculation mode
 ECO mode: The machine is in economy mode.	 Compressor ON: At least one compressor is active
 HEAT mode : The machine is in heat mode	 Alarm: There is at least one alarm Press the "alarm" key to view it
 COOL mode: The machine is in cool mode.	 Scheduling Mode: The scheduling is active.
 Defrosting Mode: The machine is defrosting.	



11.1 Operational modes

Manual

The choice between HEATING or COOLING mode is manually carried out from keyboard, room thermostat or remote selector

(see ELECTRIC CONNECTIONS chapter).

Automatic

The choice between HEATING or COOLING mode automatically happens from electronic module depending on the room temperature, detected by the probe in unit return.

With temperatures above the cold set, the unit cools the room, with temperatures below the hot set, it heats.

ECO

In this operational mode the minor consumption compared to comfort is privileged:

- the ECO-COOL set is higher than the COOLING set
- the ECO-HEAT set is lower than the HEATING set

In this mode, the fan periodically activates to verify the room temperature and decide whether to activate or not the available resources to satisfy the set.

It can be activated from the keypad with the status change key, via the scheduler or from the supervisor.

FAN

Ventilation only; all the resources devoted to thermoregulation are disabled (compressors, electric heaters, humidifier, etc).

11.2 Setpoint (temperature)

Manual temperature setpoint

The room setpoint can be MANUALLY modified from keyboard at parameter n. 01 ManSet = xx °C .

Starting from this value, the module determines 2 setpoint:

COOLING = manset + dead area/2 = xx +1°C

HEATING = manset - dead area/2 = xx -1°C

Automatic temperature setpoint

The setpoint can also AUTOMATICALLY adjust to the outdoor temperature and some parameters variations (modifiable from after-sales assistance centres)

The choice between MANUAL or AUTOMATIC setpoint happens by modifying the parameter

53 En Climatica =

0 manual operation

0 automatic operation

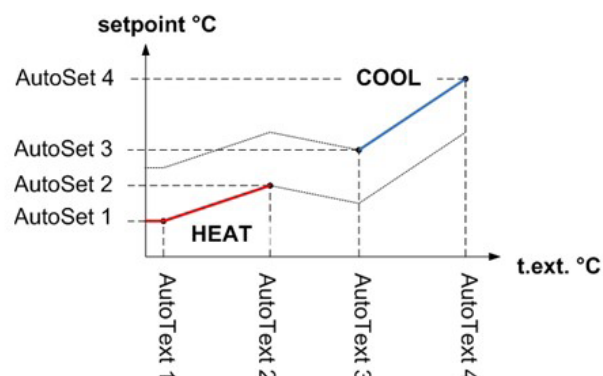

Humidity setpoint

Only for unit with enthalpy control option.

In heating, the thermoregulator will activate the humidifier by modulating the power in order to humidify the room until reaching the set at parameter 5 SptUrHeat set.

In cooling, the thermoregulator will force compressors operation in order to dehumidify the room until reaching of the set at parameter 4 SptUrCool set.

In parallel, the thermoregulator will activate the post-heating.

Set point CO₂

Only for units with CO₂/CO₂+VOC probe option.

It is possible to manage the air renewal in room based on the CO₂ concentration.

The outdoor air in room relation happens by privileging the thermoregulation requirements, therefore, only if :

- in HEATING
 - the temperature is higher than the set hot - 2°C
- in COOLING
 - the temperature is below the setcold - 2°C
- the outdoor temperature is above 16 °C



11.3 Parameters menu

Press

the access by password is reserved to qualified personnel, the parameters changes can cause malfunctions.

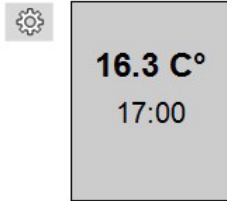

enter password (0047)

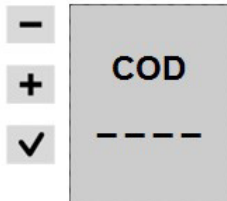

confirm

scroll the parameters

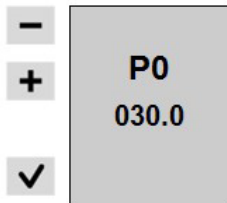

enable the parameter change
P0 starts flashing

change the value of the parameter

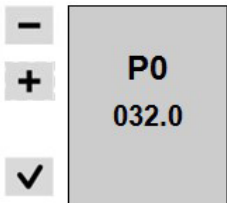

confirm the new value

select

to enable the new value and exit

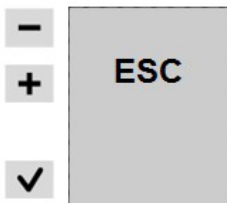

when the time is displayed
it is possible to carry out other
operations

11.4 Setpoint

To change the **manset** manual temperature Setpoint:

press

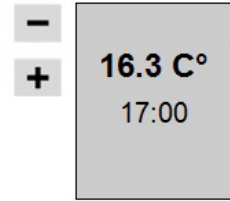

The unit:

must be On

En Climate must be = 0

Keyboard code	Mnemonic	Description
0	SetUrCool	Relative humidity setpoint in Cool mode
1	SetURHeat	Relative Humidity setpoint in Heat mode
2	SetEcoCool	Temperature setpoint in cool economy mode
3	SetEcoHeat	Temperature setpoint in heat economy mode
4	SetCO2	Air quality setpoint
5	EnClimatica	Enables setpoint from climate area
6	Priorità comando	Start-up/mode change controls priority ([0] keyboard [1] BMS)
7	EnModeAuto	Enables automatic mode change in relation to the return temperature
8	EnScheduler	Enables / disabling scheduler: 0 = disabled, 1 = enabled (P0061 service keypad)



11.5 Stata menu

Press

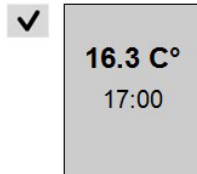

scroll the statuses

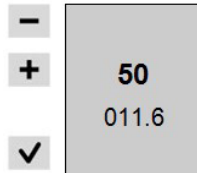

exit

wait for 3 sec

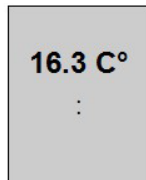

when the time is displayed it is possible to carry out other operations

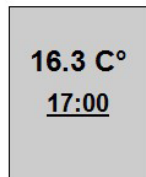

Keyboard index	Status
0	supply air temperature value [S0502];
1	outdoor air temperature value [S0501];
2	% return air humidity [S0526]
3	% outdoor air humidity [S0524]
4	air quality value [S0503]
5	number of active compressors [S0054]
6	power demand to auxiliary elements [S0010]
7	% fresh air damper control [S0511]
8	Humidifying capacity [S0031]

[S0xxxx] can also be seen with the service keypad or PC (webserver)

11.6 Date and hour

Press

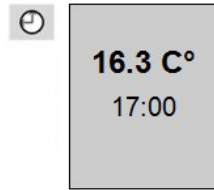

HOUR digits start flashing

edit



confirm

MINUTE digits start flashing

edit



confirm

HOUR - MINUTE digits start flashing

choose format

24h / a.m.



set

year, month, day

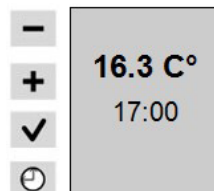

main menu

11.7 Button lock

Press for 4 sec.

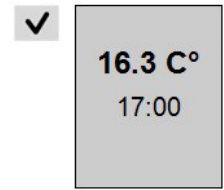

enter password (1000)

confirm

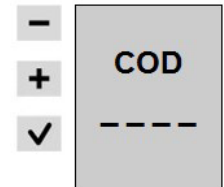

example:

T0 = "." key

ON = active key

see codes-key table

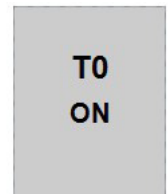

scroll the keys

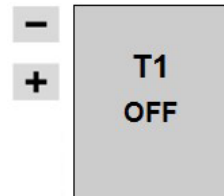

select the key

(ALL starts flashing)

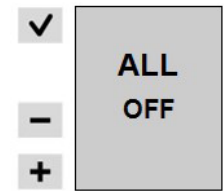

set active-ON / disabled-OFF

example:

ALL = OFF

all keys disabled

select to confirm

exit



tabella codici-tasto			
n. tasto	tasto	n. tasto	tasto
T0	-	T5	
T1	+	T6	
T2		T7	
T3		ALL	tutti i tasti
T4			



11.8 To visualize alarm in progress

WARNING

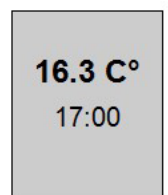
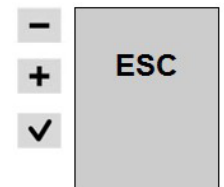
- ⚠ Before resetting an alarm identify and remove the cause that generate it.
- ⚠ Repeated reset can cause irreversible damages as maloperation of the system itself

press
only if the ALARM symbol is flashing



ee = type of alarm (see table)
0 = generic alarm (1 circuit1 alarm, etc.)
030 = progressive alarm number

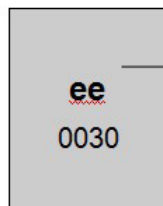

Type of alarm

Code	Type	Restore
ee	Electric	Automatic
eE	Electric	From Auto to manual*
EE	Electric	Manual
ii	Idraulic	Automatic
il	Idraulic	From Auto to manual*
ll	Idraulic	Manual
ff	Refrigerator	Automatic
fF	Refrigerator	From Auto to manual*
FF	Refrigerator	Manual
aa	Aeraulic	Automatic
aA	Aeraulic	From Auto to manual*
AA	Aeraulic	Manual

press
7 days since the alarm was triggered
17:00 alarm time



previous menu

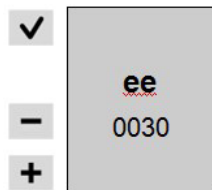

previous menu

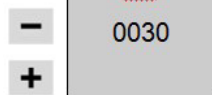

exit without alarms RESET

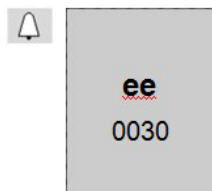

exit with alarms RESET:
scroll and select RES



* After "n" times the alarm has been triggered, it is necessary to conduct a manual reset.

The code of the circuit 2 alarms is **2nn**:

example:

fF113:DI High pressure = circuit 1

fF213:DI High pressure = circuit 2

11.9 Scheduler

WARNING

 **Enable scheduler (see: menu parametres)**

It is possible to set up to 7 schedules (1 for every day of the week)

It is possible to set up to 6 status changes for each day (On, Off, Fan).

In the days not included in the schedule, the unit maintains the most recent status defined in the schedule.

Example:

- Sunday scheduled, 23h unit in OFF mode
- Monday not scheduled (-), the unit remains in - (OFF)

Scheduling example:

Time	Event	1 Monday	2 Tuesday	3 Wednesday	4 Thursday	5 Friday	6 Saturday	7 Sunday
05:30	1	-(OFF)	FAN	-(OFF)	FAN	FAN	FAN	-(OFF)
08:00	2	FAN	ON	FAN	ON	ON	ON	FAN
13:00	3	FAN	ON	FAN	ON	ON	ON	FAN
15:00	4	FAN	ON	FAN	ON	ON	ON	FAN
18:00	5	FAN	ON	FAN	ON	ON	ON	FAN
21:00	6	OFF	OFF	OFF	OFF	OFF	OFF	OFF

Scheduling customer:

Time	Event	1 Monday	2 Tuesday	3 Wednesday	4 Thursday	5 Friday	6 Saturday	7 Sunday
05:30	1							
08:00	2							
13:00	3							
15:00	4							
18:00	5							
21:00	6							

Sequence of operations:

- 5 Set weekly scheduling (see table example)
- 6 define days with the same scheduling (ex. days 2 = 4 = 5 = 6)
- 7 select days 2,4,5,6
- 8 set event 1 (event time, state Off - On - Fan)
- 9 set event 2,3, ecc..
- 10 select days 1,3,7
- 11 set event 1,2,3, ecc..

The most recent schedule saved overrides the existing one. For instance, if a day is included in two different schedules, the most recent one saved prevails.

Scheduling days 2,4,5,6

Scheduling the 1st day, also the other days of the week are automatically scheduled.

Press 2 sec
(only if the unit is not OFF)

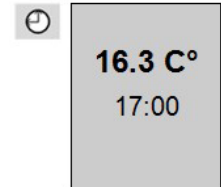

day 1 starts flashing
to go to day 2 press

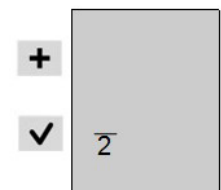

to schedule day 2 press
(2 stays steady = day 2 scheduled)

to exclude day 3 press

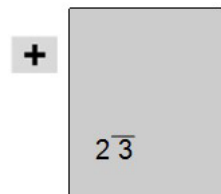

to schedule day 4 press
(4 starts flashing)

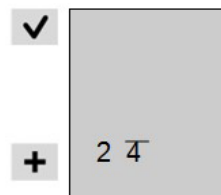

press

to schedule day 5 press
(5 stays steady)

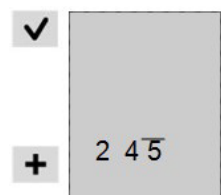

press

to schedule day 6 press
(6 starts flashing)

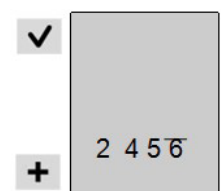

press



to exclude day 7 press

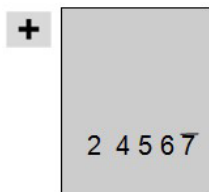

Press
to set other the events 2,3,4,5,6
repeat from **(Set event 1)**

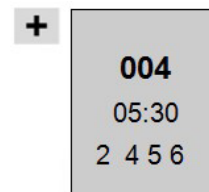

to confirm selected days press

2 4 5 6 starts flashing

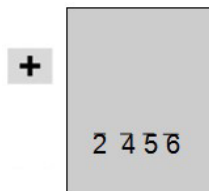

press 2 times to exit

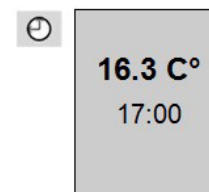

press

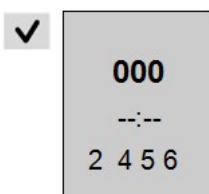

P flashing, active scheduling

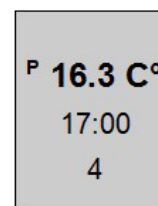

Set event 1

example: Tuesday 05:30 FAN
press
-- starts flashing

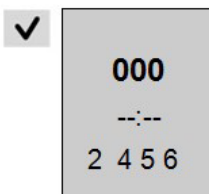

Scheduling days 1,3,7

Scheduling the 1st day, also the other days of the week are automatically scheduled.

Press 2 sec
(only if the unit is not OFF)

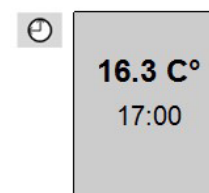

set
- event time

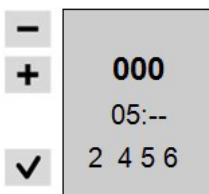

day 1 starts flashing

press

to schedule day 1 press
(1 stays steady = day 1 scheduled)
to go to day 2 press
(2 starts flashing)

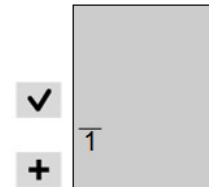

set
- eventt minutes

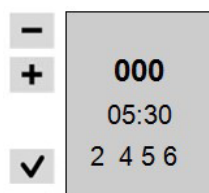

to exclude day 2 press

press

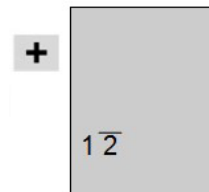

set
- desired mode
1 = null, 1 = OFF, 2 = ECO, 3 = ON, 4 = Fan

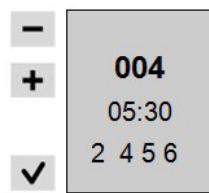

to exclude day 3 press
(3 starts flashing)

press

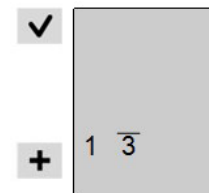



to exclude days 4,5,6
press

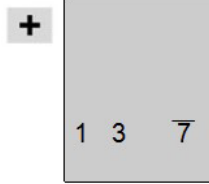

set
- eventt minutes



to schedule day 7 press
(7 starts flashing)



set
- desired mode
1 = null, 1 = OFF, 2 = ECO, 3 = ON, 4 = Fan



to confirm selected days press

1 3 7 starts flashing

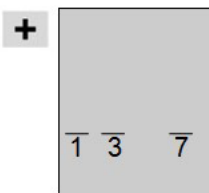

press
to set other the events 2,3,4,5,6

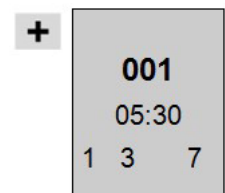

repeat from **(Set event 1)**

press

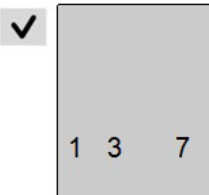

press 2 times to exit

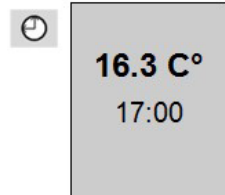

press

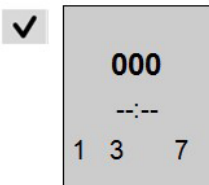

P flashing, active scheduling

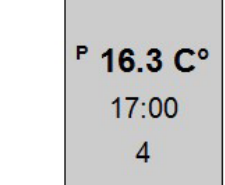

Set event 1

example: Monday 05:30 FAN

press

-- starts flashing

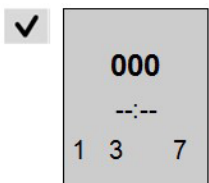

set

- event time

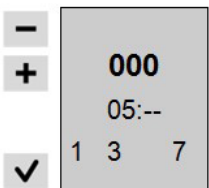

press



Modify scheduling

Example:

- day 5
- change events 3 and 4
- from **ON** to **OFF**

Time	Event	1 Monday	2 Tuesday	3 Wednesday	4 Thursday	5 Friday	6 Saturday	7 Sunday
05:30	1	-(OFF)	FAN	-(OFF)	FAN	FAN	FAN	-(OFF)
08:00	2	FAN	ON	FAN	ON	ON	ON	FAN
13:00	3	FAN	ON	FAN	ON	OFF	ON	FAN
15:00	4	FAN	ON	FAN	ON	OFF	ON	FAN
18:00	5	FAN	ON	FAN	ON	ON	ON	FAN
21:00	6	OFF	OFF	OFF	OFF	OFF	OFF	OFF

Press 2 sec

16.3 C°
17:00

press
to schedule day 5 press

5

press
(5 stays steady)

press to exclude the other days
5 starts flashing

5

press

press 3 times (= event 3)

003
13:00
5

press 3 times
starts flashing 003 (= ON)

003
13:00
5

confirm

002
13:00
5

press

002
15:00
5

press 4 times (= event 4)

003
15:00
5

press 3 times
starts flashing 003 (= ON)

003
15:00
5

select mode 002 (=OFF)

confirm

002
15:00
5







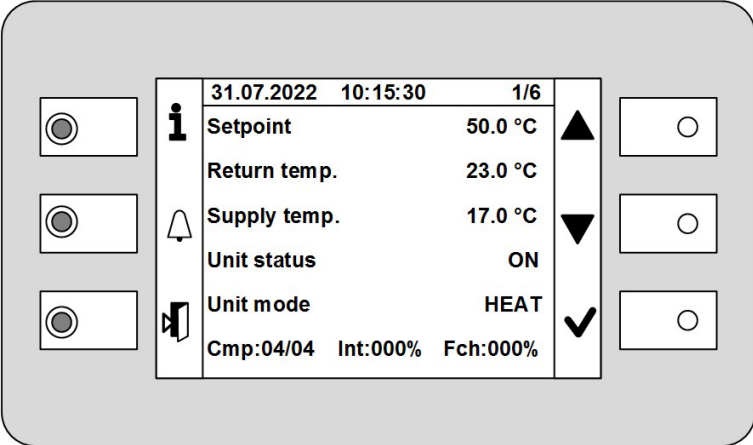

press 2 times to exit

16.3 C°
17:00

11.10 Service keypad POL871











Function keys

-  Main menu
-  Alarm display
-  Exit
-  Previous level
-  Keyboard settings
-  Up
Increases value
-  Down
Decreases value
-  Confirm
Password

Display meaning

SetPoint	temperature setting Return temperature Supply temperature	Cmp	Number of active compressors
Unit state	ON / OFF / ECO / FAN	Int	% Integration
Unit mode	Cool : cooling Heat : heating	Fch	% FreeCooling/Heating

Common operations

ON, OFF, ECO, FAN				main menu → cmd local status → choose OFF - ON - ECO - FAN
change MODE				main menu → cmd local mode → select COOL - HEAT
change SETPOINT				main menu → unit parameters → setpoint



11.11 Main menu

(pwd 8210)

Select

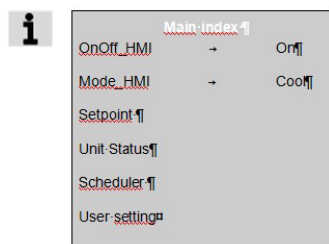

Select the menu

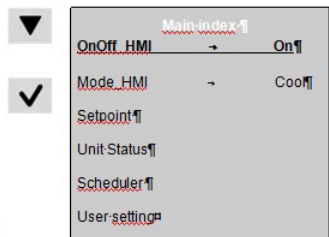

Confirm

Cmd unit	ON
	ECO
	ON
	Fan
Unit mode	Cool
	Heat
SetPoint	Manual Setpoint
	ECOSetCool
	ECOSptHeat
	SetURCool *
	SetURHeat *
	SetQualitàAria *
	SetDemandLimit *
	AutoSet1 *
	AutoSet2 *
	AutoSet3 *
	AutoSet4 *
	Auto T.Ext1 *
	Auto T.Ext2 *
	Auto T.Ext3 *
	Auto T.Ext4 *
Unit Stata	Unit
	Thermoregulator
	Serial communication
Scheduler	EnScheduler
User configuration	Current language
	IP settings
	Password settings
Assistance utility	Unit info
	Reset Pin/Password User

11.12 Scheduler

It is possible to set 6 events (Off, Eco, On, Recirculating) for each week day.

Scheduler must be enabled:

- display : actual value = On
- pag xy : unit parameters service-maintenance, P0500=1

Select

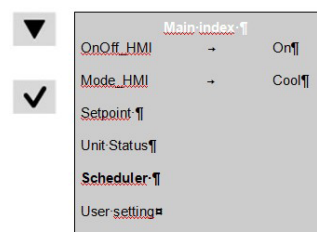

Confirm

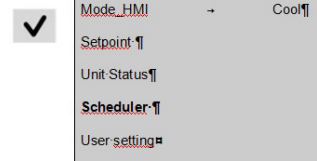

Select

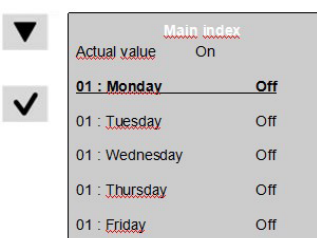

Confirm



Select

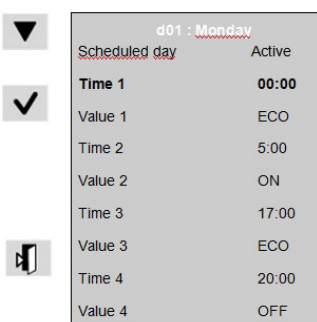

Confirm



Setting

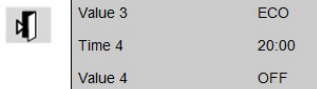

Select

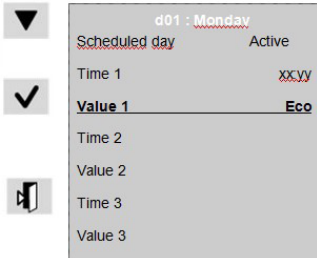

Confirm

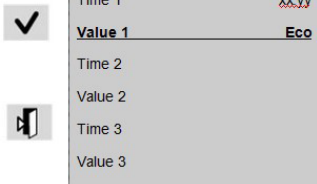

Setting

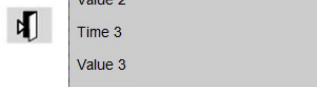

* if option present



11.13 Keyboard settings

Press 3 sec

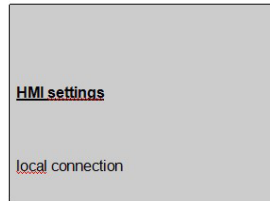

Select

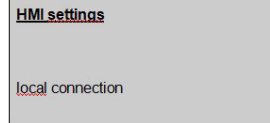

Confirm

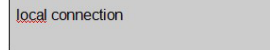

To exit

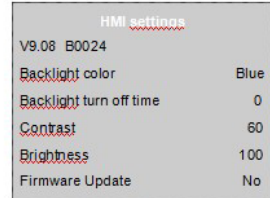

To exit

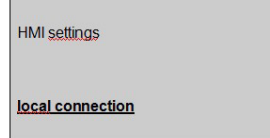

Select

Confirm



11.14 To Visualize alarm in progress



Before resetting an alarm identify and remove the cause that generate it.



Repeated reset can cause irreversible damages as maloperation of the system itself.



In case of doubt please contact an Assistance Centre.

Press

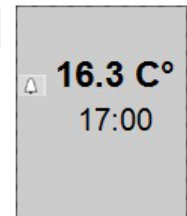

Press

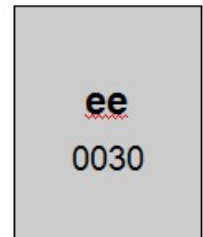

Press



Scroll

+ eE001 : Monitore fase : Fault = active alarm

- EE003 : Guasto P1 Util : Ok = resetted alarm

11.15 Reset alarm

Press



Press

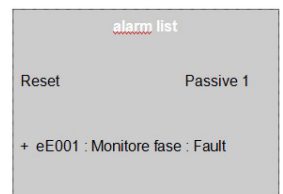



Press

Scroll

Press 3 sec.

Enter password: Maintenance
Manufacturer
Confirm

Press

Select

Confirm

Select

Confirm

Select

Exit

Press 3 sec.

Select

Confirm

alarm log

Reset Passivo 10

+ eE001 : Monitore fase : Fault

- EE003 : Guasto P1 Util : Ok

+ EE003 : Guasto P1 Util : Fault

.....

Password

Password

0 - - -

alarm list

Reset **Passive 1**

+ eE001 : Monitore fase : Fault

Passive

Active

alarm list

Reset **Passive 0**

password-management

Log-off

Change PSS-user

Change PSS-service

Change PSS-manufacturer

11.16 Main menù installer use

Press 3 sec.

Enter password Maintenance (1000)

Password

Password

0 - - -

the access by password is reserved to qualified personnel, the parameters changes can cause malfunctions.

Main index

OnOff_HMI → On

Mode_HMI → Cool

Setpoint

Unit-Status

Scheduler

User setting

Service utilities

Select

Confirm

Main index

OnOff_HMI → On

Mode_HMI → Cool

Setpoint

Unit-Status

Scheduler

User setting

Service utilities

OnOff_HMI	
Mode_HMI	
Setpoint	
Unit Stata	General
	Handling
	Integrations
	humidity control
	Circuit 1
	Circuit 2
	Multisensor
Unit settings	Serial communication
Scheduler	Scheduler
User configuration	Language
	IP settings
	Password settings
Assistance utility	Unit info
	Manual controls
	SD Utility
	Rest Pin/Password User

11.17 Alarms

ID	Alarms	Description	Reset
AA003	AERAULIC	Fire	M
aa004	AERAULIC	Dirty filters	A
aa008	AERAULIC	Low Supply Airflow	A
aa010	AERAULIC	SetPAmb not set	A
eE001	ELECTRIC	Phase Monitor	M
EE002	ELECTRIC	Open Compartment	M
EE005	ELECTRIC	Electrostatic filters	A
ee006	ELECTRIC	Offline I/O module [Addr.2]	A
eE007	ELECTRIC	Supply Fans Protection	A/M
ee008	ELECTRIC	Offline I/O module [Addr.3]	A
eE009	ELECTRIC	Exhaust Fans Protections	A/M
EE010	ELECTRIC	High T. Auxiliary Heaters	M
EE011	ELECTRIC	Ovl. Auxiliary Heaters	M
ee012	ELECTRIC	Humidifer fault	A
ee020	ELECTRIC	POL822 Offline	A
ee027	ELECTRIC	Return Temp. Probe	A
ee028	ELECTRIC	Supply Temp. Probe	A
ee029	ELECTRIC	Outdoor Temp. Probe	A
ee032	ELECTRIC	Outdoor R.H% Probe	A
ee033	ELECTRIC	Return Air Quality Probe	A
ee034	ELECTRIC	T.In Probe Aux.H2O	A
ee035	ELECTRIC	BPM Pressure Sensor	A
ee036	ELECTRIC	BPA Pressure Sensor	A
ee037	ELECTRIC	Renewal Mod. AI	A
ee038	ELECTRIC	Antifreeze Probe Aux.H2O	A
ee039	ELECTRIC	Supply Duct Press. Sensor	A
ee044	ELECTRIC	Offline I/O module [Addr.4]	A
ee047	ELECTRIC	Antifreeze Probe Rec.H2O	A
ee048	ELECTRIC	Variable Qset AI	A
ee049	ELECTRIC	ExFlow Mod. AI	A
ee050	ELECTRIC	Electrical Box Temp. Probe	A
ee051	ELECTRIC	T.In Probe Rec.H2O	A
ee053	ELECTRIC	Return R.H% Probe	A
ee054	ELECTRIC	Extern. Air Quality Probe	A
ee055	ELECTRIC	Supply R.H% Probe	A
ee056	ELECTRIC	Barometrical Damp. Feedback	A
ee060	ELECTRIC	Multisensor Probe 1	A
ee061	ELECTRIC	Multisensor Probe 2	A
ee062	ELECTRIC	Multisensor Probe 2	A
ee063	ELECTRIC	Multisensor Probe 2	A
ee101	ELECTRIC	Offline I/O module [Addr.1]	A
ee104	ELECTRIC	EEV blockage	A
EE106	ELECTRIC	Cmp.1 Protection	M
EE107	ELECTRIC	Cmp.2 Protection	M
EE118	ELECTRIC	Source Fan Protection	M
ee122	ELECTRIC	T.Discharge Probe	A
ee127	ELECTRIC	T.Suction Probe	A
ee128	ELECTRIC	P.Discharge Probe	A

ee129	ELECTRIC	P.Suction Probe	A
ee204	ELECTRIC	EEV blockage	A
EE206	ELECTRIC	Cmp.1 Protection	A
EE207	ELECTRIC	Cmp.2 Protection	A
EE218	ELECTRIC	Source Fan Protection	A
ee222	ELECTRIC	T.Discharge Probe	A
ee227	ELECTRIC	T.Suction Probe	A
ee228	ELECTRIC	P.Discharge Probe	A
ee229	ELECTRIC	P.Suction Probe	A
FF001	REFRIGERATION	Refrigerant Leak	M
ff110	REFRIGERATION	Cool low pressure pre-alarm	A
ff111	REFRIGERATION	Heat low pressure pre-alarm	A
ff112	REFRIGERATION	Low Pressure AI	A/M
ff113	REFRIGERATION	High pressure DI	A/M
ff114	REFRIGERATION	High pressure pre-alarm	A
ff115	REFRIGERATION	High pressure AI	A/M
ff116	REFRIGERATION	Pre.AlmMax.Compress.Ratio	A
ff117	REFRIGERATION	Min.Compress.Ratio	A/M
FF119	REFRIGERATION	Max.Compress.Ratio	M
FF134	REFRIGERATION	Empty Ref. Circuit	M
FF136	REFRIGERATION	DFR not available for Demand Limit	M
FF146	REFRIGERATION	L.P.Limit	M
ff210	REFRIGERATION	Cool low pressure pre-alarm	A
ff211	REFRIGERATION	Heat low pressure pre-alarm	A
ff212	REFRIGERATION	Low Pressure AI	A/M
ff213	REFRIGERATION	High pressure DI	A/M
ff214	REFRIGERATION	High pressure pre-alarm	A
ff215	REFRIGERATION	High pressure AI	A/M
ff216	REFRIGERATION	Pre.AlmMax.Compress.Ratio	A
ff217	REFRIGERATION	Min.Compress.Ratio	A/M
FF219	REFRIGERATION	Max.Compress.Ratio	M
FF234	REFRIGERATION	Empty Ref. Circuit	M
FF236	REFRIGERATION	DFR not available for Demand Limit	M
FF246	REFRIGERATION	L.P.Limit	M
ii012	HYDRAULIC	Antifreeze Aux.H2O	A/M
ii048	HYDRAULIC	Antifreeze Rec.H2O	A

Type of alarm

A automatic reset

M manual reset

A/M automatic reset , after N alarm → manual reset



11.18 States

ID	U.M.	Level
S0051:Operating Mode	-	U
S0050:Operating Status	-	U
S0507:ON/OFF Rem. D.I.	-	I
S0508:Heat/Cool Rem. D.I.	-	I
S0513:Cmd Cumulative Alarm	-	U
S0501:Outdoor Temp.	°C	U
S0524:RH% Outdoor	%	U
S0500:Return Air Temp.	°C	U
S0502:Supply Air Temp.	°C	U
S0503:Return Air Quality	ppm	U
S0526:RH% Return	%	U
S0049:Supply Q Air	m³/h	U
S0049:Setpoint supply Q Air	m³/h	U
S0525:dP Supply Duct	Pa	I
S0510:%Cmd Supply Fans	%	I
S0516:Cmd Supply Fans	-	I
S0511:%Cmd External Damp.	%	I
S0512:%Cmd Exhaust Fans	%	I
S0514:Cmd Fan/Damp.Exhaust	-	I
S0520:Cmd Min.Ext.AirDamp.	-	I
S0506:Tw.in H2OAux.Coil	°C	I
S0521:Antifreeze H2OAux.Coil	°C	I
S0527:%Cmd Auxiliary	%	I
S0529:Cmd Pmp.Auxiliary	-	I
S0530:Cmd Auxiliary Heater	-	I
S0523:Tw.in H2ORec.Coil	°C	I
S0522:Antifreeze H2ORec.Coil	°C	I
S0032:Cmd Humidifier	-	U
S0538:ExFlow Analog. Input	%	I
S_ExFlow_I1	-	I
S_ExFlow_I2	-	I
S_ExFlow_I3	-	I
S_ExFlow_I4	-	I
S_ExFlow_I5	-	I
S_ExFlow_I6	-	I
S_ExFlow_I7	-	I
S0070:Temperature MS	°C	I
S0071: Humidity MS	%	I
S0072:CO2 MS	ppm	I
S0073:VOC MS	ppm	I
S0074:CO MS	ppm	I
S0075:Noise MS	dB	I
S0076:Ambient pressure MS	mbar	I
S0077:CH4 MS	ppm	I
S0078:NO2 MS	ppm	I
S0079:Temp.Multisensor 1	°C	I
S0080:RH%.Multisensor 1	%	I

S0081:CO2.Multisensor 1	ppm	I
S0082:VOC.Multisensor 1	ppm	I
S0083:CO.Multisensor 1	ppm	I
S0084:Noise.Multisensor 1	dB	I
S0085:Amb.Press.Multisensor 1	mbar	I
S0086:CH4.Multisensor 1	ppm	I
S0087:NO2.Multisensor 1	ppm	I
S0088:Temp.Multisensor 2	°C	I
S0089:RH%.Multisensor 2	%	I
S0090:CO2.Multisensor 2	ppm	I
S0091:VOC.Multisensor 2	ppm	I
S0092:CO.Multisensor 2	ppm	I
S0093:Noise.Multisensor 2	dB	I
S0094:Amb.Press.Multisensor 2	mbar	I
S0095:CH4.Multisensor 2	ppm	I
S0096:NO2.Multisensor 2	ppm	I
S0097:Temp.Multisensor 3	°C	I
S0098:RH%.Multisensor 3	%	I
S0099:CO2.Multisensor 3	ppm	I
S0100:VOC.Multisensor 3	ppm	I
S0101:CO.Multisensor 3	ppm	I
S0102:Noise.Multisensor 3	dB	I
S0103:Amb.Press.Multisensor 3	mbar	I
S0104:CH4.Multisensor 3	ppm	I
S0105:NO2.Multisensor 3	ppm	I
S0106:Temp.Multisensor 4	°C	I
S0107:RH%.Multisensor 4	%	I
S0108:CO2.Multisensor 4	ppm	I
S0109:VOC.Multisensor 4	ppm	I
S0110:CO.Multisensor 4	ppm	I
S0111:Noise.Multisensor 4	dB	I
S0112:Amb.Press.Multisensor 4	mbar	I
S0113:CH4.Multisensor 4	ppm	I
S0114:NO2.Multisensor 4	ppm	I

Login states

U = User

I = Installer



12. SAFETY WARNINGS FOR OPERATIONS ON UNITS CONTAINING R32

12.1 Area checks

Before working on systems containing flammable refrigerants, perform safety checks to reduce the risk of combustion to the minimum. Before performing any repair operations on the cooling system, comply with the following warnings.

12.2 Work procedures

Operations must be performed following a controlled procedure so as to reduce the risk of flammable gases or vapours developing.

12.3 General work area

All the personnel in charge with maintenance operations and other operators working in the local area must be instructed and monitored as regards the nature of the intervention.

Avoid working in tight spaces. The area surrounding the working space must be cordoned off. Make sure the area is secured by monitoring the flammable material.

12.4 Check the presence of refrigerant

Both before and during operations, the area must be monitored with a dedicated refrigerant detector to make sure the technician is aware of the presence of potentially-flammable environments.

Make sure the leak detection equipment is suitable for use with flammable refrigerants and therefore without sparks, suitably sealed or intrinsically safe.

12.5 Presence of the fire extinguisher

If hot interventions are not performed on cooling equipment or connected components, suitable fire fighting equipment must be kept at hand.

Keep a dry-powder or CO₂ extinguisher near the loading area.

12.6 No ignition source

It is absolutely forbidden to use ignition sources that may lead to fire or explosion during operations on the cooling system or on pipes that contain or have contained flammable refrigerant.

All possible ignition sources, including cigarettes, must be kept sufficiently away from the installation, repair, removal and disposal site as flammable refrigerant may be released in the surrounding area.

Before starting operations, the area surrounding the equipment must be inspected to guarantee the absence of flammables or combustion risks. "SMOKING IS FORBIDDEN" signs must be affixed.

12.7 Ventilated area

Before intervening on the system or performing any hot intervention, make sure to be in an outdoor or suitably ventilated area.

Ventilation must be maintained during operations. Ventilation must disperse the released refrigerant safely, preferably outdoors in the atmosphere.

12.8 Cooling equipment checks

Should a replacement be necessary, the new components installed must be suitable for the purpose envisaged and compliant with specifications.

Always follow the manufacturer guidelines on maintenance and assistance. In case of doubt, contact the manufacturer technical office for assistance.

The following checks must be performed on systems containing flammable refrigerants:

- the quantity of the charge must comply with the size of the room where the parts containing refrigerant are installed;
- the machine and ventilation intake function correctly and are not obstructed;
- If an indirect cooling circuit is used, the secondary circuits must be checked to verify the presence of refrigerants; the marking on the equipment remains visible and readable;
- Make sure markings and symbols are always readable; cooling pipes or components must be installed in a position that makes improbable their exposure to substances that may corrode the components containing refrigerant, unless they are manufactured with material intrinsically resistant to corrosion or suitably protected against corrosion.

12.9 Electrical device checks

The repair and maintenance of electric components must include initial safety checks and component inspection procedures.

In case of a fault that compromises safety, do not perform any electrical connection to the circuit until said fault is suitably resolved.

If it is not possible to repair the fault immediately and electrical components need to remain functioning, a temporary solution must be adopted. This must be reported to the owner of the equipment so as to keep all parties informed.

Initial safety checks must include:

- that condensers are emptied. This operation must be performed safely to avoid any sparks;
- that electrical components and wiring are not exposed during the charging, recovering or venting phases;
- That the earth conductor is continuous.

12.10 Repairing sealed components



- During the reparation operations of sealed components, disconnect all the equipment before removing sealed casings etc. If, during operations, it is absolutely necessary for the equipment to remain connected, a leak detection device must be placed in the most critical point so as to report any potentially-dangerous situation.
- Pay particular attention to what follows to guarantee that, while intervening on electrical components, the housing is not altered in a way so as to affect the level of protection. This includes damage to cables, an excessive number of connections, terminals not compliance with the original specifications, damage to gaskets, an unsuitable installation of gaskets, etc.
- Make sure the device is installed safely.
- Check that the seals or sealing materials are not altered in such a way that they no longer impede the entry of flammable environments. Spare parts must comply with manufacturer specifications.

WARNING

- Using silicone sealants may inhibit the effectiveness of a few types of leak detection equipment. It is not necessary to isolate intrinsically safe components before performing operations on them.**

12.11 Reparation of intrinsically safe components

Do not apply permanent inductive or capacitive loads to the circuit without making sure that they do not exceed the admissible voltage and current allowed for equipment in use.

Intrinsically safe components are the only component type on which operations can be performed in a flammable atmosphere. The testing device must show a correct value. Replace components only with the parts specified by the manufacturer.

Following a leak, other parts could lead to the combustion of the refrigerant in the atmosphere.

12.12 Wires

Make sure wires are not subjected to wear, corrosion, excessive pressure or vibration, that there are no sharp edges and that they do not produce other negative effects on the environment. The inspection must also keep into consideration the effects of time or the continuous vibration caused e.g. by compressors or fans.

12.13 Detection of flammable refrigerants

Under no circumstance is it possible to use potential ignition sources to search or detect refrigerant leaks.

Do not use halide lights (or any other open flame detectors).

12.14 Leak detection methods

The following leak detection methods are considered acceptable for systems containing flammable refrigerants. Electric leak detectors must always be used to identify flammable refrigerants, although they do not present a suitable sensitivity level or require recalibration (detection equipment must be calibrated in an area free from refrigerants).

Check that the detector is not a possible source of ignition and that it is suitable for the refrigerant. Leak detection equipment must always be set to an LFL percentage and calibrated depending on the refrigerant used, so the correct gas percentage (25% max) must be verified.

Leak detection fluids are suitable for most refrigerants, although using detergents containing chlorine should be avoided as this substance may react with the refrigerant and corrode copper pipes.

If a leak is suspected, all open flames must be removed or switched off.

If a leak is identified that requires brazing, all the refrigerant must be recovered from the system or isolated (using interception valves) in a section of the system far away from the leak. Oxygen-Free-Nitrogen (OFN) is then purged through the system both before and during the brazing procedure.

12.15 Removal and evacuation

When intervening on the cooling circuit to perform repair work or any other type of work, always follow the normal procedure. However, considering the risk of flammability, we recommend following the best practices. Comply with the following procedure:

- remove the refrigerant;
- purge the circuit with inert gas;
- evacuate;
- purge again with inert gas;
- interrupt the circuit with interruption or brazing.

The refrigerant charge must be collected in suitable recovery tanks. To make the unit safe, flushing with Oxygen-free-Nitrogen must be performed. This procedure may have to be repeated multiple times. Do not use compressed air or oxygen for this operation.

Flushing is obtained interrupting the system vacuum with OFN and filling until the operating pressure is obtained, then releasing into the atmosphere and restoring the vacuum. This process must be repeated until there is no trace of refrigerant in the system.

When using the final OFN charge, the system must be vented to the atmospheric pressure to allow the intervention. This step is essential to perform brazing operations on the pipes.

Make sure that the vacuum pump intake is not near ignition sources and that there is suitable ventilation.

12.16 Charging operations

In addition to conventional charging operations, the following requirements must be complied with:



- When using charging equipment, make sure that the various refrigerants are not contaminated. Flexible tubes or conduits must be as short as possible to reduce to the minimum the quantity of refrigerant contained.
- Tanks must be kept in a vertical position.
- Before loading the system with refrigerant, check that the cooling system is earthed.
- Label the system when fully charged (unless already labelled).
- Make sure not to fill the cooling system excessively.
- Before recharging the system, the pressure must be tested with OFN. A leak test must be performed after the charging operations but before commissioning. Before leaving the site, perform an additional leak test.

12.17 Dismantling

Before performing this procedure, it is essential that the technician has become familiar with the equipment and the relative details.

We recommend employing good practices for a safe recovery of the refrigerants.

Before performing the operation, take a sample of oil and refrigerant should an analysis be necessary before reusing the regenerated refrigerant. Before performing the operation, check the availability of electricity.

- Become familiar with the equipment and how it functions.
- Electrically isolate the system.

Before attempting the procedure, check that:

- The mechanical manipulation equipment is available, if necessary, to handle refrigerant tanks;
- All the personal protection equipment is available and employed correctly;
- The recovery procedure is monitored at all times by skilled personnel;
- The recovery equipment and tanks comply with suitable standards.
- If possible, pump the cooling system.
- If it is not possible to obtain a vacuum, make sure that a collector removes the refrigerant from various parts of the system.
- Before proceeding with the recovery, check that the tank is located on the scales.
- Start up the recovery machine and use it following the instructions by the manufacturer.
- Do not fill the tanks excessively. (Do not exceed 80% of the liquid volume).
- Do not exceed the tank's maximum operating pressure, not even momentarily.
- Once the tanks are filled correctly and the process is over, make sure that the tanks and equipment are immediately removed from the site and that all insulation valves on the equipment are closed.
- The refrigerant recovered must not be loaded into another cooling system unless it has been cleaned and checked.

12.18 Labelling

Equipment must be labelled reporting the dismantling and emptying of the refrigerant.

Labels must be dated and signed.

Make sure all the equipment is labelled and reporting the presence of flammable refrigerant.

12.19 Recovery

When removing the refrigerant from the system, please adopt good practices to remove all refrigerants safely in case of both assistance or decommissioning operations.

When transferring the refrigerant into the tanks, make sure only suitable tanks are used to recover the refrigerant.

Make sure enough tanks are used.

All the tanks to be used are designated for the recovered refrigerant and are labelled for that specific refrigerant (e.g. special tanks for refrigerant collection).

Tanks must be equipped with a perfectly-functioning safety valve and relative interception valves.

Empty recovery tanks are evacuated and, if possible, cooled before recovery.

Recovery equipment must be perfectly functioning with the respective instruction booklets at hand and they must be suitable to recover flammable refrigerants. A series of perfectly-functioning calibrated scales must also be available.

Flexible tubes must be equipped with leak-proof disconnection fittings in good condition. Before using the recovery machine, make sure it is in good condition, maintained and that all associated electrical components are sealed to avoid combustion in case of a refrigerant leak. Please contact the manufacturer in case of doubt.

The refrigerant recovered must be taken to the supplier in suitable recovery tanks and with the relative waste transfer note suitably filled in.

Do not mix the refrigerants in the recovery units nor in the tanks.

If it is necessary to remove compressors or compressor oils, make sure they are evacuated to an acceptable level to make sure no trace is left of the flammable refrigerant inside the lubricant. The evacuation process must be performed before taking the compressors back to the suppliers.

The electric resistance must be used with the compressor body only to accelerate this process.

Operations to discharge the oil from the system must be performed in full safety.

12.20 Transport, mark and storage

- 1 Transport of equipment containing flammable refrigerants.
Compliance with transport regulations
- 2 Marking of equipment with symbols.
Compliance with local regulations



- 3** Disposal of equipment employing flammable refrigerants.
Compliance with national regulations
- 4** Storage of equipment/devices.
The equipment must be stored in compliance with the instructions provided by the manufacturer.
- 5** Storing packed (unsold) equipment.
Packing must be performed in such a way that mechanical damage to the equipment inside it does not cause refrigerant leaks. The maximum number of elements that can be stored together is determined by local regulations.



13. Maintenance

13.1 Safety

Operate in compliance with safety regulations in force.

To carry out the operations use protection devices: gloves, goggles, helmet, headphones, protective knee pads.



All operations must be carried out by personnel trained on possible risks of a general nature, electrical and deriving from operating with equipment under pressure.

Only qualified personnel can operate on the unit, as required by the regulation in force

13.2 General

Maintenance must be performed by authorized centres or by qualified personnel

The maintenance allows to:

- maintaining the unit efficient
- reduce the deterioration speed all the equipment is subject to over time
- collect information and data to understand the efficiency state of the unit and prevent possible faults



WARNING

- ⚠ Before checking, please verify the following:
- ⚠ the electrical power supply line should be isolated at the beginning
- ⚠ the unit isolator is open, locked and equipped with the suitable warning
- ⚠ make sure no tension is present
- ⚠ After turning off the power, wait at least 5 minutes before accessing to the electrical panel or any other electrical component.
- ⚠ Before accessing check with a multimeter that there are no residual stresses.

13.3 Frequency of interventions

Perform an inspection every 6 months.

However, frequency depends on the type of use.

Pan inspections at close intervals in the event of:

- frequent use (continuous or very intermittent use, near the operating limits, etc)
- critical use (service necessary)

WARNING

- ⚠ Before performing any operation, read the warnings found in the Maintenance chapter.

- ⚠ SAFETY WARNINGS FOR OPERATIONS ON UNITS CONTAINING R32



Do not go up to the surface

Not placing heavy objects

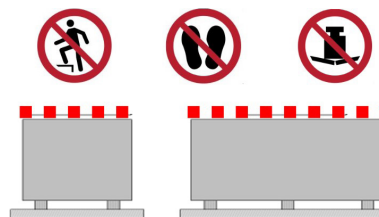



13.4 Recommended periodic checks sheet

		intervention frequency (months)	1	6	12
1	presence of corrosions				X
2	panel fixing				X
3	pan fixing			X	
4	coil cleaning			X	
5	bowl cleaning + sanitisation			X	
6	outflow test			X	
7	air filters cleaning / inspection	X			
8	air flow rate measurement				X
9	channelling: anti-vibration devices and fastenings check				X
10	check of the fixing and the insulation of the power lead				X
11	check of the earthing cable				X
12	electric panel cleaning				X
13	power remote controls status				X
14	clamp closure, cable isolation integrity				X
15	voltage and phase unbalancing (no load and on-load)			X	
16	absorptions of the single electrical loads			X	
17	compressor casing heaters test			X	
18	checking for leaks *				*
19	cooling circuit work parameter detection			X	
20	safety valve *				*
21	protective device test: pressure switches, thermostats, flow switches etc..			X	
22	control system test: setpoint, climatic compensations, capacity stepping, air flow-rate variations			X	
23	control device test: alarm signalling, thermometers, probes, pressure gauges etc			X	
24	electrical heaters check - option				X
25	water coil check - option				X

WARNING

 ***Refer to the local regulations. Companies and technicians performing installation, maintenance/repair, leak control and recovery operations must be CERTIFIED as set out by the local regulations.**



13.5 Unit booklet

It's advisable to create a unit booklet to take notes of the unit interventions.

In this way it will be easier to adequately note the various interventions and aid any troubleshooting.

Report on the booklet:

- date
- intervention description
- carried out measures etc.

13.6 Structure

Check the condition of the parts making up the structure

Paint so as to eliminate or reduce oxidation at the points in the unit where this problem may occur

Check that the panelling is fastened correctly

Poor fastening may give rise to malfunctions and abnormal noise and vibration

13.7 Outdoor air coil

Accidental contact with the exchanger flaps can cause injuries from cut: use protective gloves.

The coil must allow maximum thermal exchange, therefore, the surface must be clear from dirt and scaling.

Clean the air inlet side.

Use a soft brush or aspirator or pressurised air jet or high-pressure water jet machine.

Keep the direction parallel to the flow of the flaps to avoid damages.

Check the aluminium flaps have not been damaged or folded, on the contrary contact an authorised after-sales assistance centre to "comb" the coil for excellent air flow.

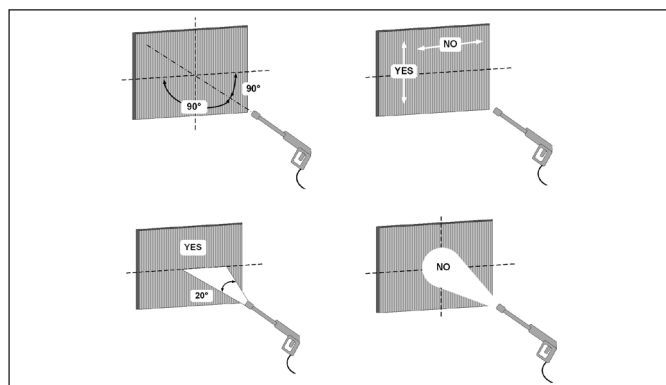

13.8 Indoor air coil

Accidental contact with the exchanger flaps can cause injuries from cut: use protective gloves.

The finned surfaces of the cooling coils and, in particular, the condense collection bowls constitute places where microorganisms and moulds greatly flourish. It is very important to foresee periodical cleaning with suitable detergents and, eventually, disinfect with sanitising products.

It is very important to foresee periodical cleaning with suitable detergents and, eventually, disinfect with sanitising products.

13.9 Condensation collection basin

Dirt or scale can give rise to clogging.

Also, microorganisms and mould can flourish in the bowl.

It is very important to foresee periodical cleaning with suitable detergents and, eventually, disinfect with sanitising products.

Once cleaning is completed, pour water inside the bowl to check the regular outflow.

13.10 G4 (ISO 16890 Coarse 60%) Folded air filters

It is very important for the air treatment coil to offer maximum thermal exchange: the unit must always work with clean and installed filters. Cleaning and replacement of filters are very important from an hygienic-sanitary point of view.

It is very important for the air treatment coil to offer maximum thermal exchange: the unit must always work with clean and installed filters. Cleaning and replacement of filters are very important from an hygienic-sanitary point of view.

Operation with clogged filters leads to a reduction in the air flow rate with malfunctionings and block, up to possible breaks in the unit.

The frequency with which the filters must be checked depends on the quality of the outdoor air, the unit operation hours, the dustiness and crowding of rooms.

Frequency can indicatively vary from WEEKLY to MONTHLY. It is advised to start with frequent checks, subsequently adjusting frequency to degree of detected dirt.

Remove the closing panels

Delicately remove the filter avoiding dirtying the area below

Check the condition, if necessary proceed with the replacement

Do not wash the filters, washing can compromise their functionality.

Old filters must be disposed of according to the current standards.

13.11 F7 filters (ISO 16890 and PM1 55%)/F9 (ISO 16890 ePM1 80%)

Option

The filters are not renewable, once dirty they must be replaced.

- 1 open the access panel
- 2 delicately remove the filter avoiding dirtying the area below
- 3 insert the new filters, with the pockets vertically



- 4 close the panel
- 5 dispose of the old filters sending them to specialised recycling or collection centres (keep to the standards in force)

13.12 IFD Electronic filters (ISO 16890 and PM1 90%)

Impurities can cause a decrease in filtration efficiency and also an increase in the load losses of the component which increase the power consumption of the supply fan. For this reason it is mandatory to clean the filter.

⚠ Do not use water hotter than 50°C to clean the filters.

⚠ Do not use air hotter than 50°C to dry the filters.

Below is the sequence to follow:

- 1 Remove the iFd filter cell from the aluminum frame
- 2 First use a soft brush or vacuum cleaner to clean the floating dust on the surface of the filter; then clean the module with water (you can directly put the module on the faucet for washing)
- 3 Then spray the kitchen cleanser evenly on the IFD filter and ensure that the front and back sides and the holes are sprayed with cleanser (But, strong acid and strong alkaline type cleanser is strictly prohibited)
- 4 Wait for 5~10 mins
- 5 Then, use a soft brush to remove the dust on the surface of the filter (be careful not to damage the module)
- 6 Finally, wash the IFD filter with clean water (if part of the IFD filter is not cleaned, it is recommended to repeat the above 1-5 steps)
- 7 It is recommended to dry the filter cell in an open or dry place.

Closed and / or humid places can prevent the filter from completely drying. The entire cell must dry completely before restoring the electrical connections on the machine. Make sure the filter cell electrical connectors are completely dry before making the connections. A connector that is still wet / damp can cause irreversible damage to the entire filter cell.



13.13 Electric heaters

Option

Check:

- cleaning state
- fastening
- presence of corrosion

13.14 Compressor casing heater

Check:

- correct fixing
- operation (with compressor OFF -> heater ON and vice versa)

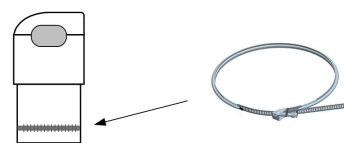



13.15 Immersed electrodes humidifier

Option

⚠ Connexion humidificateur: 1" F

Do not use solvents or detergents to clean the plastic components.

For descaling use a vinegar or acetic acid solution at 20%, subsequently rinsing with water

Periodical checks	
15 days	Cylinder: not over 300 hours of work checking operation, general state, no leaks
90 days	Cylinder: not over 1000 hours of work checking operation, general state, no leaks, any replacement
1 year	Cylinder: not over 2500 hours of work (disposable cylinders) Load solenoid valve replacement: disconnect electric power supply, dismantle valve, clean the drain solenoid valve filter: Drain solenoid valve: disconnect electric power supply, remove reel and dismantle valve body and any impurity and rinse. The power supply bowl, piping: check they are free and without impurities.
5 year	Cylinder: not over 10000 hours of work (inspectional cylinders) replacement

Humidifier cylinder drainage

Cylinder must be drained in these situations:

- cleaning of the cylinder
- emptying of the cylinder to avoid ice forming
- replacement of the cylinder

The manual drainage is carried out by means of selector SA7: see ELECTRIC CONNECTIONS chapter.

13.15.01 Replacement of the cylinder

To remove the cylinder:

- completely drain the water
- interrupt power supply voltage of humidifier by means of the unit isolator
- remove the vapour pipe from the cylinder
- disconnect the electric connections of the electrodes and remove the pins from the high level electrodes
- loosen the ring nut to remove the pipe unions and the filter (when filter is outside the cylinder)
- lift the cylinder to remove it

Before mounting it:

- the filter body does not require replacing, wash it with water and remount it on the new cylinder, using the new gasket provided with the latter
- check the seal gasket between the cylinder and the drain unit
- remount the cylinder repeating the operations in reverse order

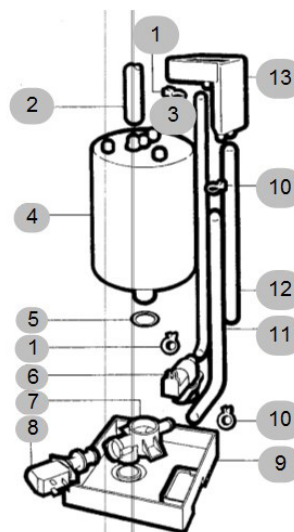

- 1 pipe fixing spring
- 2 vapour pipe
- 3 load pipe
- 4 vapour cylinder
- 5 seal O-rings
- 6 load valve
- 7 valves support
- 8 drain valve
- 9 bottom tank
- 10 pipe fixing spring
- 11 load pipe
- 12 too full pipe
- 13 fill tank

14. Decommissioning

14.1 Disconnection

WARNING

- ⚠ **Before performing any operation, read the warnings found in the Maintenance chapter.**
- ⚠ **SAFETY WARNINGS FOR OPERATIONS ON UNITS CONTAINING R32**



Avoid leak or spills into the environment.

Before disconnecting the unit, the following must be recovered, if present:

- refrigerant gas
- Anti-freeze solutions in the hydraulic circuit

Awaiting decommissioning and disposal, the unit can also be stored outdoors, as bad weather and rapid changes in temperature do not harm the environment provided that the electric, cooling and hydraulic circuits of the unit are intact and closed.

14.2 WEEE INFORMATION

The manufacturer is registered on the EEE National Register, in compliance with implementation of Directive 2012/19/EU and relevant national regulations on waste electrical and electronic equipment.

This Directive requires electrical and electronic equipment to be disposed of properly.

Equipment bearing the crossed-out wheelee bin mark must be disposed of separately at the end of its life cycle to prevent damage to human health and to the environment.

Electrical and electronic equipment must be disposed of together with all of its parts.

To dispose of “household” electrical and electronic equipment, the manufacturer recommends you contact an authorised dealer or an authorised ecological area.

“Professional” electrical and electronic equipment must be disposed of by authorised personnel through established waste disposal authorities around the country.

In this regard, here is the definition of household WEEE and professional WEEE:

WEEE from private households: WEEE originating from private households and WEEE which comes from commercial, industrial, institutional and other sources which, because of its nature and quantity, is similar to that from private households. Subject to the nature and quantity, where the waste from EEE was likely to have been by both a private household and users of other than private households, it will be classed as private household WEEE;

Professional WEEE: all WEEE which comes from users other than private households.

This equipment may contain:

- refrigerant gas, the entire contents of which must be recovered in suitable containers by specialised personnel with the necessary qualifications;
- lubrication oil contained in compressors and in the cooling circuit to be collected;
- mixtures with antifreeze in the water circuit, the contents of which are to be collected;
- mechanical and electrical parts to be separated and disposed of as authorised.

When machine components to be replaced for maintenance purposes are removed or when the entire unit reaches the end of its life and needs to be removed from the installation, waste should be separated by its nature and disposed of by authorised personnel at existing collection centres.



15. Residual risks

General

In this section the most common situations are indicated, as these cannot be controlled by the manufacturer and could be a source of risk situations for people or things.

Danger zone

This is an area in which only an authorised operator may work.

The danger zone is the area inside the unit which is accessible only with the deliberate removal of protections or parts thereof.

Handling

The handling operations, if implemented without all of the protection necessary and without due caution, may cause the drop or the tipping of the unit with the consequent damage, even serious, to persons, things or the unit itself.

Handle the unit following the instructions provided in the present manual re-garding the packaging and in compliance with the local regulations in force.

Should the refrigerant leak please refer to the refrigerant "Safety sheet".

Installation

The incorrect installation of the unit could cause water leaks, condensate accumulation, leaking of the refrigerant, electric shock, poor operation or damage to the unit itself.

Check that the installation has been implemented by qualified technical personnel only and that the instructions contained in the present manual and the local regulations in force have been adhered to.

The installation of the unit in a place where even infrequent leaks of inflammable gas and the accumulation of this gas in the area surrounding the area occur could cause explosions or fires.

Carefully check the positioning of the unit.

The installation of the unit in a place unsuited to support its weight and/or guarantee adequate anchorage may result in consequent damage to things, people or the unit itself.

Carefully check the positioning and the anchoring of the unit.

Easy access to the unit by children, unauthorised persons or animals may be the source of accidents, some serious.

Install the unit in areas which are only accessible to authorised person and/or provide protection against intrusion into the danger zone.

General risks

Smell of burning, smoke or other signals of serious anomalies may indicate a situation which could cause damage to people, things or the unit itself.

Electrically isolate the unit (yellow-red isolator).

Contact the authorised service centre to identify and resolve the problem at the source of the anomaly.

Accidental contact with exchange batteries, compressors, air delivery tubes or other components may cause injuries and/or burns.

Always wear suitable clothing including protective gloves to work inside the danger zone.

Maintenance and repair operations carried out by non-qualified personnel may cause damage to persons, things or the unit itself.

Always contact the qualified assistance centre.

Failing to close the unit panels or failure to check the correct tightening of all of the panelling fixing screws may cause damage to persons, things or the unit itself.

Periodically check that all of the panels are correctly closed and fixed.

If there is a fire the temperature of the refrigerant could reach values that increase the pressure to beyond the safety valve with the consequent possible projection of the refrigerant itself or explosion of the circuit parts that remain isolated by the closure of the tap.

Do not remain in the vicinity of the safety valve and never leave the refrigerating system taps closed.

Electric parts

An incomplete attachment line to the electric network or with incorrectly sized cables and/or unsuitable protective devices can cause electric shocks, intoxication, damage to the unit or fires.

Carry out all of the work on the electric system referring to the electric layout and the present manual ensuring the use of a system thereto dedicated.

An incorrect fixing of the electric components cover may lead to the entry of dust, water etc inside and may consequently electric shocks, damage to the unit or fires.

Always fix the unit cover properly.

When the metallic mass of the unit is under voltage and is not correctly connected to the earthing system it may be as source of electric shock and electrocution.

Always pay particular attention to the implementation of the earthing system connections.

Contact with parts under voltage accessible inside the unit after the removal of the guards can cause electric shocks, burns and electrocution.

Open and padlock the general isolator prior to removing the guards and signal work in progress with the appropriate sign.

Contact with parts that could be under voltage due to the start up of the unit may cause electric shocks, burns and electrocution.

When voltage is necessary for the circuit open the isolator on the attachment line of the unit itself, padlock it and display the appropriate warning sign.

Moving parts

Contact with the transmissions or with the fan aspiration can cause injuries.

Prior to entering the inside of the unit open the isolator situated on the connection line of the unit itself, padlock and display the appropriate warning sign.

Contact with the fans can cause injury.

Prior to removing the protective grill or the fans, open the isolator on the attachment line of the unit itself, padlock it and display the appropriate warning sign.

Refrigerant

The intervention of the safety valve and the consequent expulsion of the gas refrigerant may cause injuries and intoxication.

Always wear suitable clothing including protective gloves and eyeglasses for operations inside the danger zone.

Should the refrigerant leak please refer to the refrigerant "Safety sheet".

Contact between open flames or heat sources with the refrigerant or the heating of the gas circuit under pressure (e.g. during welding operations) may cause explosions or fires.

Do not place any heat source inside the danger zone.

The maintenance or repair interventions which include welding must be carried out with the system off.

Hydraulic parts

Defects in tubing, the attachments or the removal parts may cause a leak or water projection with the consequent damages to people, things or shortcircuit the unit.

16. Technical information

Performances - Standard airflow

Size				60.4	70.4	80.4	90.4	100.4	120.4
Cooling									
Cooling capacity		1	kW	190	213	240	269	295	343
Sensible capacity		1	kW	146	164	189	208	227	259
Compressor power input		1	kW	50,0	62,8	75,1	78,2	86,4	109,0
EER		1	-	3,81	3,39	3,19	3,44	3,41	3,13
Cooling capacity (EN14511:2018)	CAK	5	kW	191,0	213,9	240,7	270,3	296,0	344,0
EER (EN14511:2018)		5	-	3,40	3,40	3,20	3,45	3,42	3,14
SEER		6		4,76	4,70	4,37	4,45	4,33	4,17
η_{sc}		6	%	187	185	172	175	170	164
Cooling capacity		2	kW	198	222	249	280	307	356
Sensible capacity	CBK/ CBK-G	2	kW	152	171	197	217	237	269
Compressor power input		2	kW	50,5	63,7	76,2	79,3	87,6	111,0
EER		2	-	3,92	3,48	3,27	3,54	3,50	3,21
Cooling capacity		3	kW	208	232	261	294	322	374
Sensible capacity	CCK- REVO	3	kW	158	177	204	225	245	279
Compressor power input		3	kW	49,3	62,2	74,4	77,4	85,5	108,0
EER		3	-	4,21	3,74	3,51	3,80	3,76	3,44
Heating									
Heating capacity		1	kW	192	213	242	274	299	352
Compressor power input		1	kW	55,7	62,0	70,0	78,1	86,9	110,0
COP		1	-	3,44	3,44	3,46	3,50	3,44	3,20
Heating capacity (EN14511:2018)	CAK	7	kW	191,8	213,5	242,7	274,0	298,8	352,5
COP (EN14511:2018)		7	-	3,44	3,44	3,46	3,50	3,43	3,19
SCOP		6		3,41	3,47	3,41	3,42	3,39	3,37
η_{sh}		6	%	133	136	133	134	133	132
Heating capacity		2	kW	193	215	243	276	301	354
Compressor power input	CBK/ CBK-G	2	kW	51,5	57,3	64,7	72,3	80,4	102,0
COP		2	-	3,75	3,74	3,76	3,82	3,74	3,49
Heating capacity		3	kW	200	222	252	286	311	367
Compressor power input	CCK- REVO	3	kW	51,2	57,0	64,3	71,8	79,9	101,0
COP		3	-	3,91	3,90	3,92	3,98	3,90	3,63
Recovery efficiency REVO		4	%	86	86	84	77	78	80

The Product is compliant with the Erp (Energy Related Products) European Directive. It includes the Commission delegated Regulation (EU) No 2016/2281, also known as Ecodesign Lot21.

Contains fluorinated greenhouse gases (GWP 675)

Performances in cooling: Indoor air temp. 27°C D.B./19°C W.B., Entering external exchanger air temperature 35°C D.B./24°C W.B., EER referred only to compressors

Performance in Heating: Indoor air temp. 20°C D.B./12°C W.B., entering air to the external exchanger 7°C D.B./6°C W.B. COP referred only to compressors

- 1 Full recirculation performance
- 2 Performance with 30% outdoor air
- 3 Performance with 30% outdoor air, including energy recovery on exhaust air
- 4 Energy recovery efficiency determined on exhaust air. Indoor temperature 20°C DB/12°C WB, outdoor temperature 7°C DB/6°C WB
- 5 Full recirculation capacity according to EN 14511-2018, indoor air temperature 27°C DB/19°C WB; outdoor temperature 35°C. EER in accordance with EN 14511-2018
- 6 Data calculated in compliance with EN 14825:2018.
- 7 Full recirculation capacity according to EN 14511-2018, indoor air temperature 20°C; outdoor temperature 7°C DB/6°C WB COP in accordance with EN 14511-2018

Construction - Standard airflow

Size			60.4	70.4	80.4	90.4	100.4	120.4
Compressor								
Type of compressors	1		SCROLL	SCROLL	SCROLL	SCROLL	SCROLL	SCROLL
No. of compressors		Nr	4	4	4	4	4	4
Refrigeration circuits		Nr	2	2	2	2	2	2
Std capacity control steps		Nr	4	6	6	6	4	6
Refrigerant charge (C1)	2	kg	28	30	32,5	40	42	47
Refrigerant charge (C2)	2	kg	28	30	32,5	38	40	48
Air Handling Section Fans (Supply)								
Type of supply fan/motor	3		RAD/EC	RAD/EC	RAD/EC	RAD/EC	RAD/EC	RAD/EC
Fan diameter		mm	560	560	560	560	560	560
No. of supply fans		Nr	4	4	4	6	6	6
Supply airflow		m ³ /h	33000	37000	44000	49000	53000	58000
Installed unit power		kW	3,5	3,5	3,5	3,5	3,5	3,5
Max. static pressure supply fan	4	Pa	869	763	578	860	807	741
Installed unit power		kW	5,8	5,8	5,8	5,8	5,8	5,8
Max. static pressure supply fan	4	Pa	1396	1231	943	1419	1286	1119
Fans (Exhaust) only configuration CBK-G + EWX								
Type of fans/motor			RAD/EC	RAD/EC	RAD/EC	RAD/EC	RAD/EC	RAD/EC
No. of fans			2	2	2	2	2	2
Installed unit power			3,5	3,5	3,5	3,5	3,5	3,5
Fans (Exhaust) only configuration CCK-REVO								
Type of fans/motor			RAD/EC	RAD/EC	RAD/EC	RAD/EC	RAD/EC	RAD/EC
No. of fans			2	2	2	2	2	2
Installed unit power			2,67	2,67	2,67	3,95	3,95	3,95
External Section Fans								
Type of fans/motor	5		AXIAL/AC	AXIAL/AC	AXIAL/AC	AXIAL/AC	AXIAL/AC	AXIAL/AC
Fan diameter		mm	800	800	800	800	800	800
No. of fans		Nr	4	4	4	6	6	6
Airflow		m ³ /h	84000	84000	84000	126000	126000	126000
Installed unit power		kW	1,72	1,72	1,72	1,72	1,72	1,72
Connections								
Condensate drain		mm	30	30	30	30	30	30
Power supply								
Standard power supply		V	400/3~/50	400/3~/50	400/3~/50	400/3~/50	400/3~/50	400/3~/50

1 Indicative values for standard units with possible +/-10% variation. The actual data are indicated on the label of the unit

2 RAD = Radial fan - EC = Electronically Commutated

3 Net pressure available to overcome flow and return pressure losses

4 AXIAL = Axial fan - AC = Alternating current

Sound levels - Standard mode

SIZE	Sound power level (dB)								Sound power level dB(A)	Sound pressure level dB(A)
	Octave band (Hz)									
	63	125	250	500	1000	2000	4000	8000		
60.4	111	98	93	88	86	79	73	84	92	72
70.4	113	99	95	90	88	85	79	82	94	74
80.4	116	102	98	94	91	91	81	83	97	77
90.4	112	100	95	89	88	88	81	75	95	74
100.4	113	101	96	91	89	89	81	76	96	75
120.4	114	102	98	93	93	93	83	76	98	77

The sound levels are referred to unit operating at nominal load in nominal conditions. The sound pressure level is referred at a distance of 1 m from the ducted unit surface operating in free field conditions. External static pressure 50 Pa. (standard UNI EN ISO 9614-2)

Measurements are carried out accordingly to UNI EN ISO 9614-2, as required by Eurovent Certification EUROVENT 8/1. It requires a 2 dB(A) tolerance on sound power level, only acoustic value to be certified.

Please note that when the unit is installed in conditions different from nominal test conditions (e.g. near walls or obstacles in general), the sound levels may undergo substantial variations.

Specific sound performance according to different configuration are available on demand.

Operating range (Cooling)

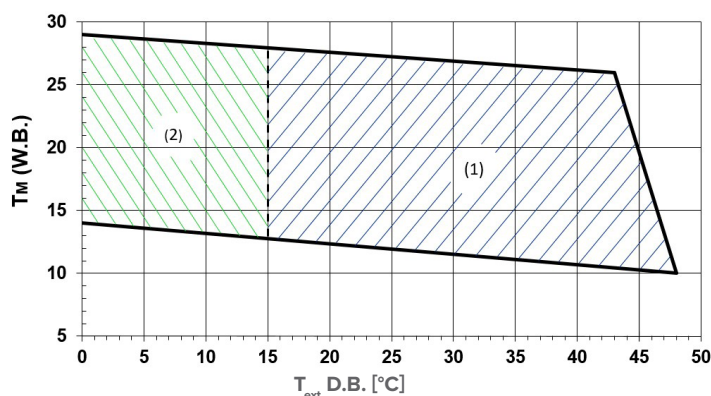

The limits are meant as an indication and they have been calculated by considering:

- general and non specific sizes,
- standard airflow,
- non-critical positioning of the unit and correct operating and maintenance of the unit,
- operating at full load

To verify the operation field of the operating units with percentages of outdoor air, always calculate the T_m mixing temperature at the internal heat exchanger input.

T_m = Inlet air temperature in the internal exchanger
wet bulb temperature (W.B.= WET BULB)

T_{ext} = External exchanger inlet air temperature
measured temperature with wet bulb (W.B.=WET BULB)

Within its operating range, the unit can work at a partialized load to maximise energy efficiency

- 1 Standard unit operating range
- 2 Operating range of the unit in FREE-COOLING mode (CBK-G and CCK-REVO versions)

Wet bulb temperature - example

25°C W.B. { 40°C D.B. / 30% R.H.
35°C D.B. / 45% R.H.
30°C D.B. / 67% R.H.



Operating range (Heating)

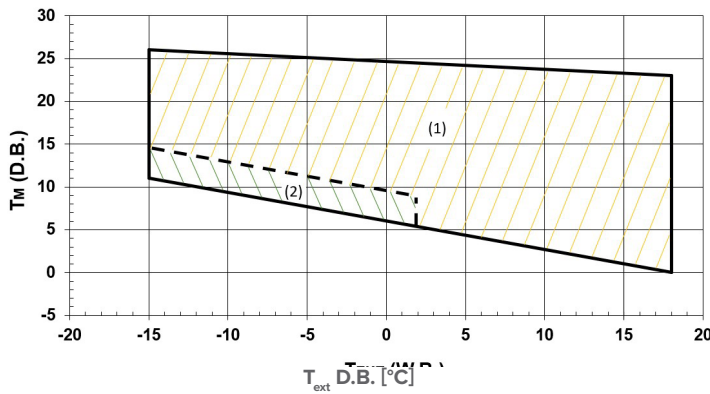

The limits are meant as an indication and they have been calculated by considering:

- general and non specific sizes,
- standard airflow,
- non-critical positioning of the unit and correct operating and maintenance of the unit,
- operating at full load

To verify the operation field of the operating units with percentages of outdoor air, always calculate the T_m mixing temperature at the internal heat exchanger input.

T_m = Inlet air temperature in the internal exchanger measured temperature with wet bulb (W.B.=WET BULB)

T_{ext} = External exchanger inlet air temperature wet bulb temperature (W.B.= WET BULB)

Within its operating range, the unit can work at a partialized load to maximise energy efficiency

- 1 Standard operating range
- 2 Range in which the unit operation is allowed only for a limited period (max 1 hour)

In prolonged heat pump mode with an ambient temperature below $6^{\circ}C$, the unit carries out defrosting cycles with cycle inversion to eliminate the ice that forms on the surfaces of the external exchanger. Moreover, in the event of negative temperatures, it is important to promote the evacuation of water produced by defrosting to avoid the accumulation of ice near the base of the unit. Ensure this does not pose a hazard to property or persons.

With outdoor air temperatures between $-10^{\circ}C$ and $-25^{\circ}C$, the following options will be required:

- Hot water coil / Gas heating module
- Application for low outdoor temperature

17. Dimensional

CSRN-Y 60.4 - 80.4 version CAK / CBK / CBK - G / CCK - REVO

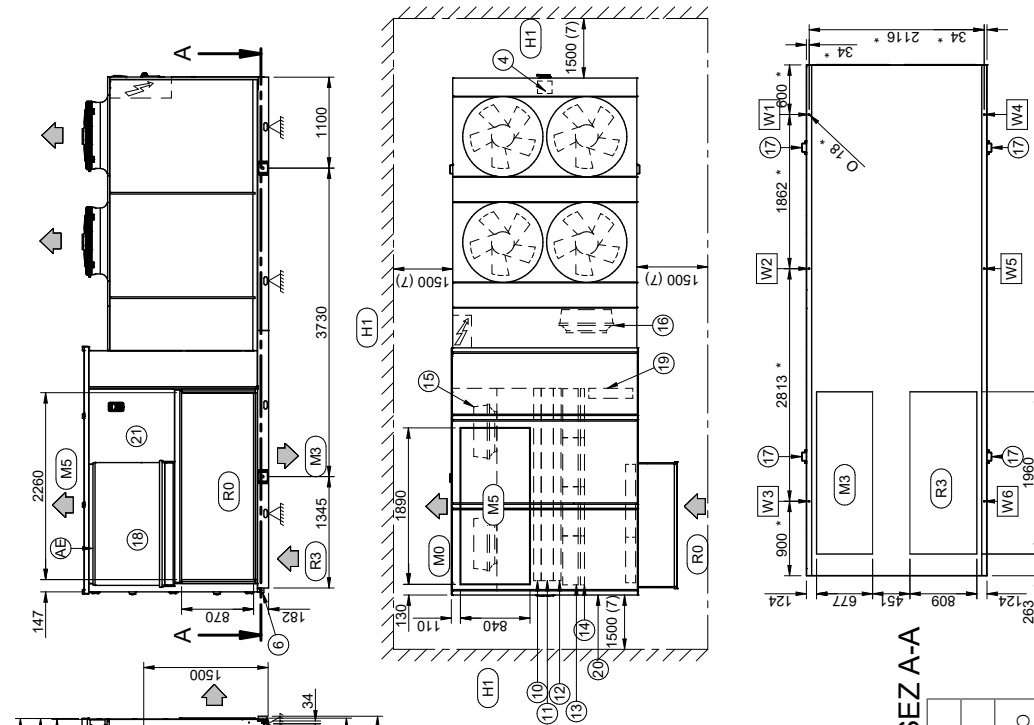

- 1 Compressor compartment
 - 2 Electrical panel
 - 3 Connector for keyboard or PC connection
 - 4 Power input
 - 5 Humidifier connections 1/2" M
 - 6 Condensate drain with siphon
 - 7 Functional spaces
 - 8 Heating coil inlet H₂O \varnothing 2"
 - 9 Heating coil outlet H₂O \varnothing 2"
 - 10 Post-heating coil
 - 11 Treatment coil
 - 12 Heating coil H₂O
 - 13 Filters F7 - Filters F9 - Electrostatic filters
 - 14 Filters G4
 - 15 Electric fan (supply-return)
 - 16 Discharge fun (CCK REVO version)
 - 17 Liftin bracket (Removed)
 - 18 Fresh air damper
 - 19 Over pressure damper discharge (CCK REVO Version)
 - 20 Coil-filters-heaters inspection
 - 21 Outdoor air return cap (accessory disassembled)
- (R3) Downward air return
 (M0) Horizontal air supply
 (M3) Downward air supply
 (M5) Vertical air supply
 (AE) Outdoor air return (CBK / CBK-G / CCK-REVO version)
 (H) Wall with same height as unit on a maximum of three sides
 (*) Vibration mounts position

SEZA-A

		WEIGHT DISTRIBUTION			
Version	Size	60.4	70.4	80.4	80.4
		CAK/CBK / CBKG	CAK/CBK/ CBKG	CAK/CBK/ CBKG	CCK-REVO
		CCK-REVO	CCK-REVO	CCK-REVO	CCK-REVO
W1	Support point	Kg 413	423	417	417
W2	Support point	Kg 495	506	541	541
W3	Support point	Kg 451	450	457	457
W4	Support point	Kg 409	419	402	402
W5	Support point	Kg 474	483	584	584
W6	Support point	Kg 363	362	383	383
	Operation weight	Kg 2605	2643	2783	2783
	Shipping weight	Kg 2605	2643	2783	2783

Optional accessories may result in a substantial variation of the weight show in table

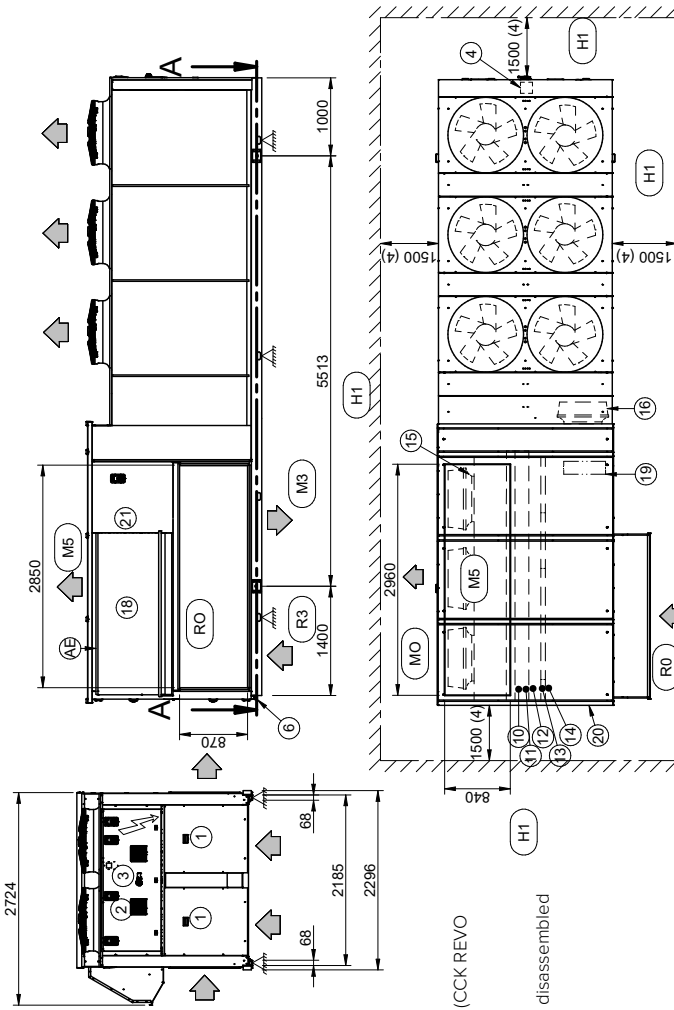

- | | |
|------------------------------------------------------------------------------------------------------------------------------------------------------------------------------------------------------------------------------------------------------------------------------------------------------------------------------------------------------------------------------------------------------------------------------------------------------------------------------------------------------------------------------------------------------------------------------------------------------------------------------------------------------------------------------|----------------------------------------------------------------------------------------------------------------------------------------------------------------------------------------------------------------------------------------------------------------------------------------------------------------------------------------------------------------------------------------------------------------------------------------------------------------------------------------------------------------------------------------------------------------------------------------------------------------------|
| <ul style="list-style-type: none"> 1 Compressor compartment 2 Electrical panel 3 Connector for keyboard or PC connection 4 Power input 5 Humidifier connections 1/2"™ 6 Condensate drain with siphon 7 Functional spaces 8 Heating coil inlet H₂O ø 2" 9 Heating coil outlet H₂O ø 2" 10 Post-heating coil 11 Treatment coil 12 Heating coil H₂O 13 Filters F7 - Filters F9 - Electrostatic filters 14 Filters G4 15 Electric fan (supply-return) 16 Discharge fan (CCK REVO version) | <ul style="list-style-type: none"> 17 Liftin bracket (Removed) 18 Fresh air damper 19 Over pressure damper discharge (CCK REVO Version) 20 Coil-filters-heaters inspection 21 Outdoor air return cap (accessory disassembled supplied) (R3) Downward air return (M0) Horizontal air supply (M3) Downward air supply (M5) Vertical air supply (AE) Outdoor air return (CBK / CBK-G / CCK-REVO version) (H1) Wall with same height as unit on a maximum of three sides (*) Vibration mounts position |
|------------------------------------------------------------------------------------------------------------------------------------------------------------------------------------------------------------------------------------------------------------------------------------------------------------------------------------------------------------------------------------------------------------------------------------------------------------------------------------------------------------------------------------------------------------------------------------------------------------------------------------------------------------------------------|----------------------------------------------------------------------------------------------------------------------------------------------------------------------------------------------------------------------------------------------------------------------------------------------------------------------------------------------------------------------------------------------------------------------------------------------------------------------------------------------------------------------------------------------------------------------------------------------------------------------|

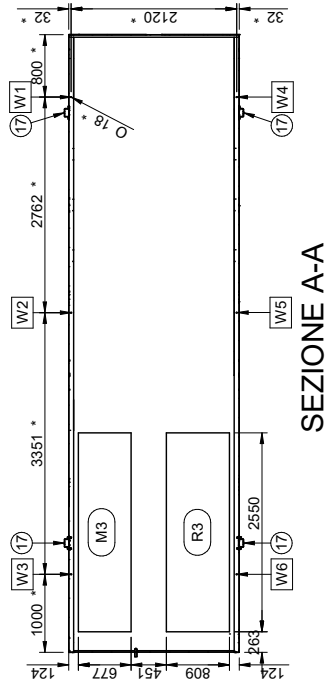

Size		WEIGHT DISTRIBUTION					
		90.4	100.4	100.4	120.4	120.4	
Version		CAK/CBK / CBKG	CCK-REVO	CAK/CBK/ CBKG	CCK-REVO	CCK-REVO	
W1	Support point	Kg	558	569	558	640	628
W2	Support point	Kg	686	686	767	734	815
W3	Support point	Kg	582	582	603	576	597
W4	Support point	Kg	541	541	529	598	586
W5	Support point	Kg	691	691	782	740	831
W6	Support point	Kg	467	467	490	461	484
Operation weight		Kg	3536	3536	3728	3750	3942
Shipping weight		Kg	3536	3536	3728	3750	3942

Optional accessories may result in a substantial variation of the weight show in table

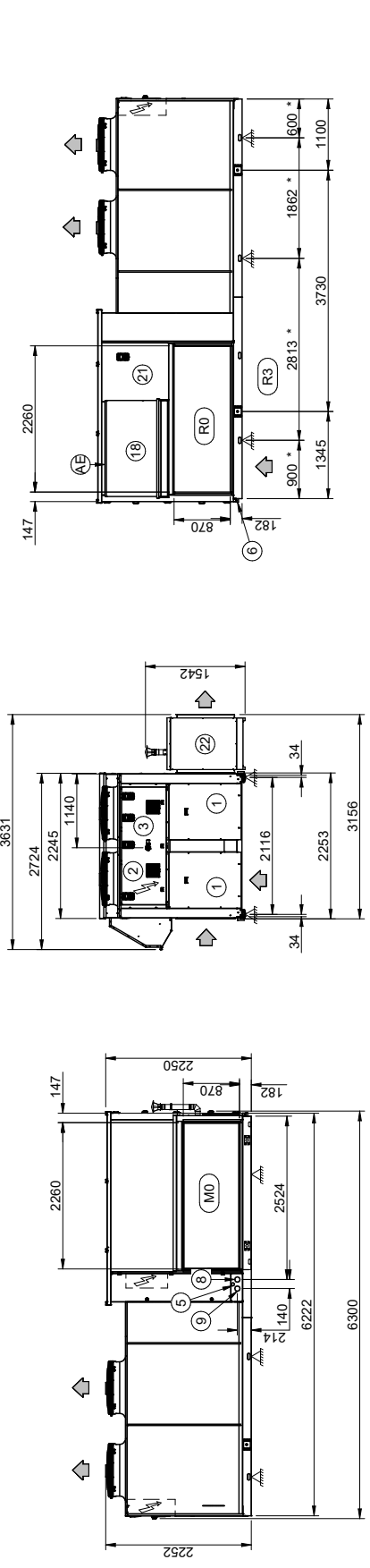

- 1 Compressor compartment
 - 2 Electrical panel
 - 3 Connector for keyboard or PC connection
 - 4 Power input
 - 5 Humidifier connections 1/2" M
 - 6 Condensate drain with siphon
 - 7 Functional spaces
 - 8 Heating coil inlet H₂O ø 2"
 - 9 Heating coil outlet H₂O ø 2"
 - 10 Post-heating coil
 - 11 Treatment coil
 - 12 Heating coil H₂O
 - 13 Filters F7 - Filters F9 - Electrostatic filters
 - 14 Filters G4
 - 15 Electric fan (supply-return)
 - 16 Discharge fun (CCK REVO version)
 - 17 Liften bracket (Removed)
 - 18 Fresh air damper
 - 19 Over pressure damper discharge (CCK REVO Version)
 - 20 Coil-filters-heaters inspection
 - 21 Outdoor air return cap (accessory disassembled supplied)
 - 22 Gas module
- (RO) Horizontal air return
 (R3) Downward air return
 (M0) Horizontal air supply
 (AE) Outdoor air return (CBK / CBK-G / CCK-REVO version)
 (H1) Wall with same height as unit on a maximum of three sides
 (*) Vibration mounts position

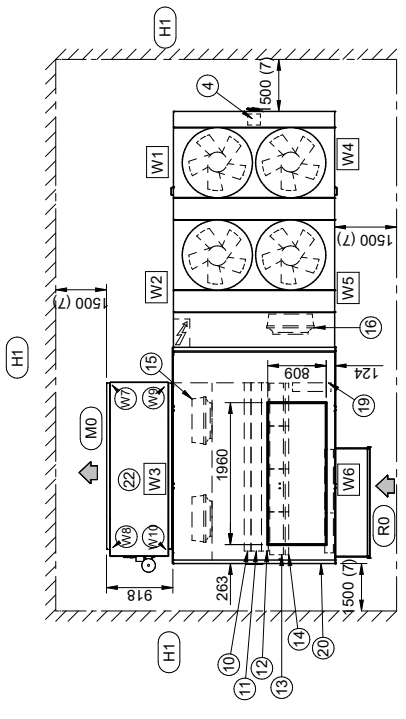

Version		WEIGHT DISTRIBUTION			
		60.4	70.4	80.4	80.4
Size		CAK/CBK / CBKG	CCK-REVO	CAK/CBK/ CBKG	CCK-REVO
W1	Support point	Kg 413	407	423	417
W2	Support point	Kg 495	530	506	541
W3	Support point	Kg 451	458	450	457
W4	Support point	Kg 409	392	419	402
W5	Support point	Kg 474	575	483	584
W6	Support point	Kg 363	383	362	383
Operation weight		Kg 2605	2745	2643	2783
Shipping weight		Kg 2605	2745	2643	2783

Optional accessories may result in a substantial variation of the weight show in table

GAS MODULE WEIGHT DISTRIBUTION		60.4 - 70.4 - 80.4
W7	Support point	Kg 85
W8	Support point	Kg 75
W9	Support point	Kg 75
W10	Support point	Kg 85
Operation weight		Kg 320
Shipping weight		Kg 320

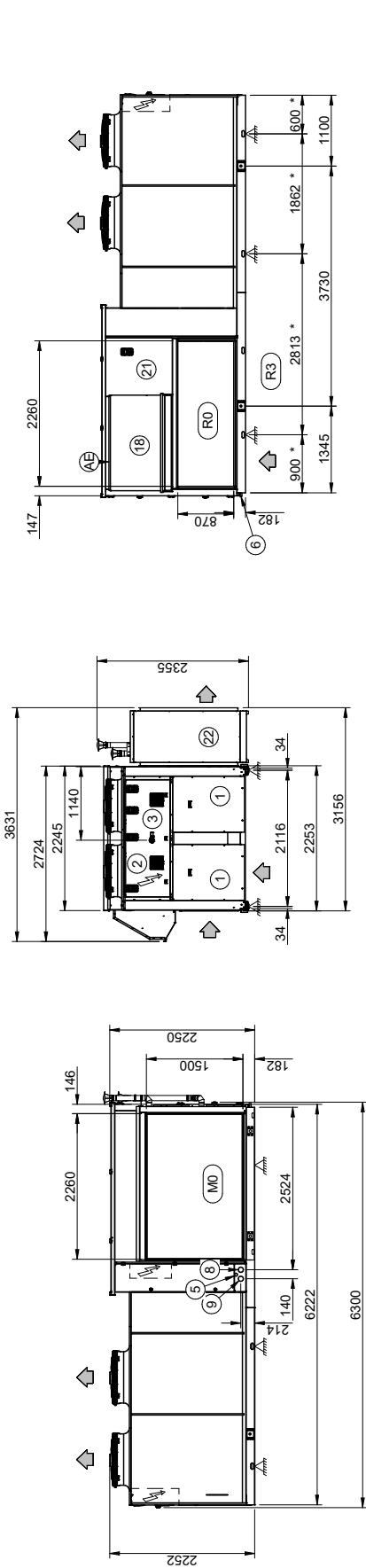

- 1 Compressor compartment
 - 2 Electrical panel
 - 3 Connector for keyboard or PC connection
 - 4 Power input
 - 5 Humidifier connections 1/2" M
 - 6 Condensate drain with siphon
 - 7 Functional spaces
 - 8 Heating coil inlet H₂O ø 2"
 - 9 Heating coil outlet H₂O ø 2"
 - 10 Post-heating coil
 - 11 Treatment coil
 - 12 Heating coil H₂O
 - 13 Filters F7 - Filters F9 - Electrostatic filters
 - 14 Filters G4
 - 15 Electric fan (supply-return)
 - 16 Discharge fun (CCK REVO version)
 - 17 Lifting bracket (Removed)
 - 18 Fresh air damper
 - 19 Over pressure damper discharge (CCK-REVO Version)
 - 20 Coil-filters-heaters inspection
 - 21 Outdoor air return cap (accessory disassembled supplied)
 - 22 Gas module
- (RO) Horizontal air return
 (R3) Downward air return
 (MO) Horizontal air supply
 (AE) Outdoor air return (CBK / CBK-G / CCK-REVO version)
 (H1) Wall with same height as unit on a maximum of three sides
 (*) Vibration mounts position

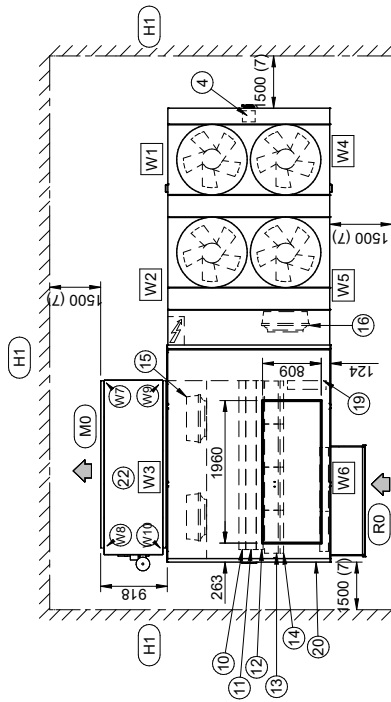

GAS MODULE WEIGHT DISTRIBUTION		60.4 - 70.4 - 80.4	
Size			
W7 Support point	Kg	145	
W8 Support point	Kg	100	
W9 Support point	Kg	145	
W10 Support point	Kg	100	
Operation weight	Kg	490	
Shipping weight	Kg	490	

		WEIGHT DISTRIBUTION			
Version	Size	60.4	70.4	80.4	80.4
		CAK/CBK / CBKG	CAK/CBK / CBKG	CAK/CBK / CBKG	CCK-REVO
W1 Support point	Kg	413	423	423	417
W2 Support point	Kg	495	506	506	541
W3 Support point	Kg	451	450	450	457
W4 Support point	Kg	409	419	419	402
W5 Support point	Kg	474	483	483	584
W6 Support point	Kg	363	362	362	383
Operation weight	Kg	2605	2643	2643	2783
Shipping weight	Kg	2605	2643	2643	2783

Optional accessories may result in a substantial variation of the weight show in table

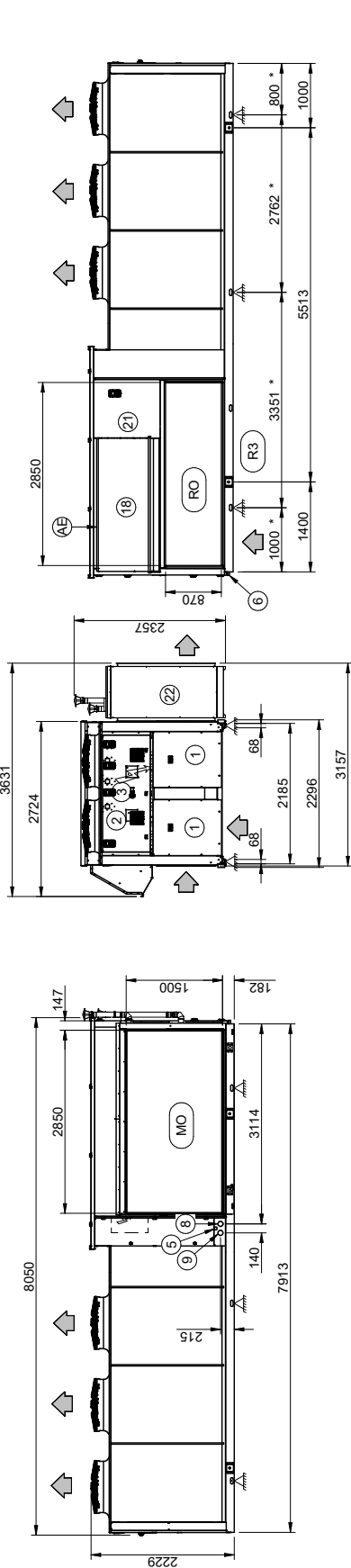

- 1 Compressor compartment
- 2 Electrical panel
- 3 Connector for keyboard or PC connection
- 4 Power input
- 5 Humidifier connections 1/2" M
- 6 Condensate drain with siphon
- 7 Functional spaces
- 8 Heating coil inlet H₂O ø 2"
- 9 Heating coil outlet H₂O ø 2"
- 10 Post-heating coil
- 11 Treatment coil
- 12 Heating coil H₂O
- 13 Filters F7 - Filters F9 - Electrostatic filters
- 14 Filters G4
- 15 Electric fan (supply-return)
- 16 Discharge fun (CCK REVO version)
- 17 Liftin bracket (Removed)
- 18 Fresh air damper
- 19 Over pressure damper discharge (CCK REVO Version)
- 20 Coil-filter-heaters inspection
- 21 Outdoor air return cap (accessory disassembled supplied)
- 22 Gas module
(RO) Horizontal air return
(R3) Downward air return
(MO) Horizontal air supply
(AE) Outdoor air return (CBK / CBK-G / CCK-REVO version)
(H1) Wall with same height as unit on a maximum of three sides
(*) Vibration mounts position

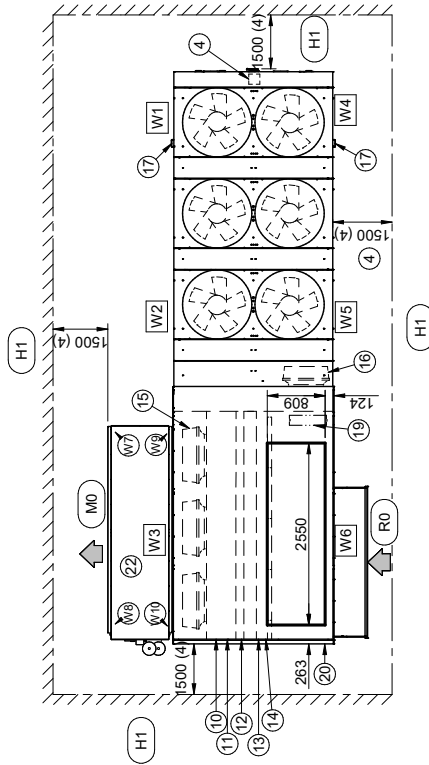

Version		WEIGHT DISTRIBUTION			
		90.4	100.4	100.4	120.4
W1	Support point	569	569	558	640
W2	Support point	686	686	767	734
W3	Support point	582	582	603	576
W4	Support point	541	541	529	598
W5	Support point	691	691	782	740
W6	Support point	467	467	490	461
Operation weight		3536	3536	3728	3750
Shipping weight		3536	3536	3728	3942

Size		GAS MODULE WEIGHT DISTRIBUTION	
		90.4 - 100.4 - 120.4	110
W7	Support point	Kg	155
W8	Support point	Kg	100
W9	Support point	Kg	155
W10	Support point	Kg	530
Operation weight		Kg	530
Shipping weight		Kg	530

Optional accessories may result in a substantial variation of the weight show in table

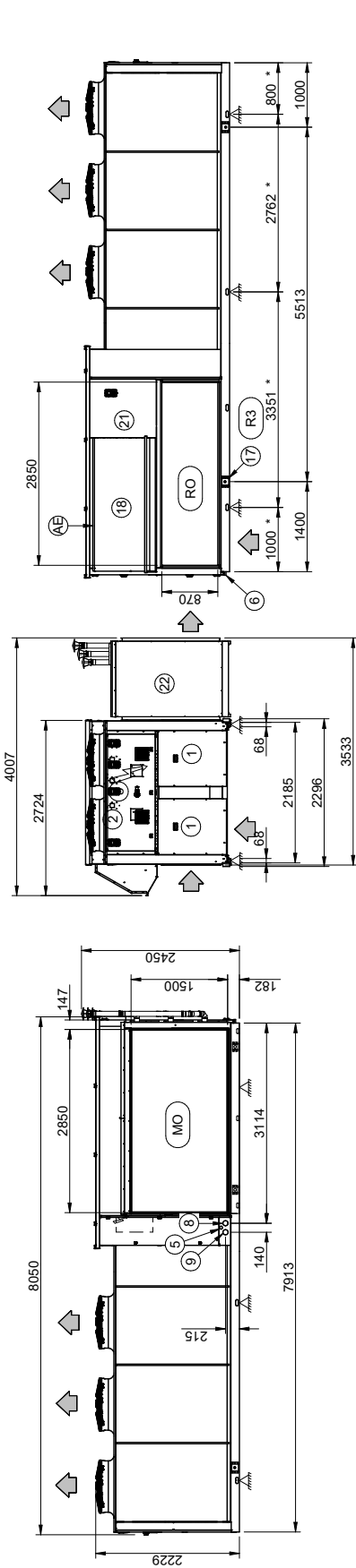

- 1 Compressor compartment
 - 2 Electrical panel
 - 3 Connector for keyboard or PC connection
 - 4 Power input
 - 5 Humidifier connections 1/2" M
 - 6 Condensate drain with siphon
 - 7 Functional spaces
 - 8 Heating coil inlet H₂O ø 2"
 - 9 Heating coil outlet H₂O ø 2"
 - 10 Post-heating coil
 - 11 Treatment coil
 - 12 Heating coil H₂O
 - 13 Filters F7 - Filters F9 - Electrostatic filters
 - 14 Filters G4
 - 15 Electric fan (supply-return)
 - 16 Discharge fun (CCK REVO version)
 - 17 Lifin bracket (Removed)
 - 18 Fresh air damper
 - 19 Over pressure damper discharge (CCK REVO Version)
 - 20 Coil-filters-heaters inspection
 - 21 Outdoor air return cap (accessory disassembled supplied)
 - 22 Gas module
- (RO) Horizontal air return
 (R3) Downward air return
 (M0) Horizontal air supply
 (AE) Outdoor air return (CBK / CBK-G / CCK-REVO version)
 (H1) Wall with same height as unit on a maximum of three sides
 (*) Vibration mounts position

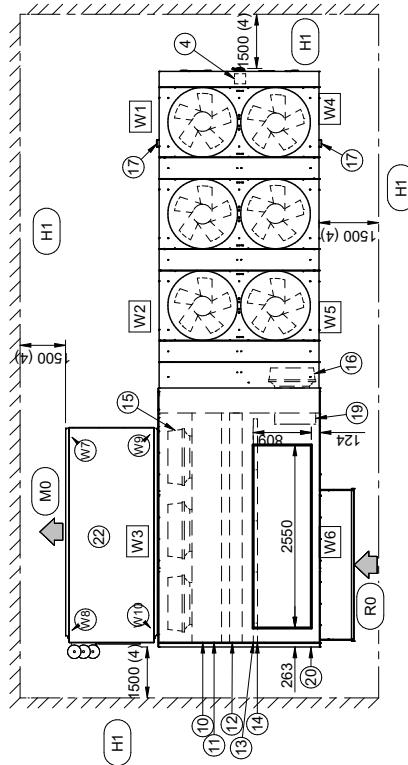

		WEIGHT DISTRIBUTION			
Version		90.4	100.4	100.4	120.4
W1	Support point	558	569	558	628
W2	Support point	767	686	767	815
W3	Support point	603	582	603	597
W4	Support point	541	541	529	586
W5	Support point	691	691	782	831
W6	Support point	467	467	490	484
Operation weight		3536	3536	3728	3942
Shipping weight		3536	3536	3728	3942

Optional accessories may result in a substantial variation of the weight show in table

		GAS MODULE WEIGHT DISTRIBUTION	
Size		90.4 - 100.4 - 120.4	
W7	Support point	Kg	165
W8	Support point	Kg	190
W9	Support point	Kg	165
W10	Support point	Kg	190
Operation weight		Kg	710
Shipping weight		Kg	710

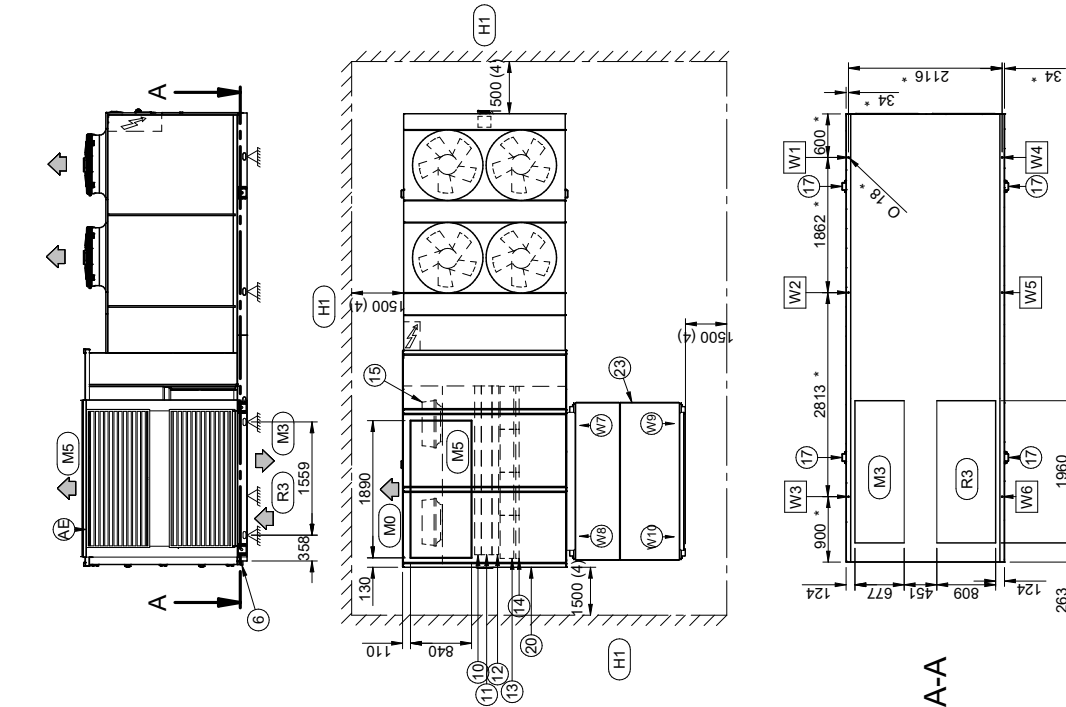

- 1 Compressor compartment
 - 2 Electrical panel
 - 3 Connector for keyboard or PC connection
 - 4 Power input
 - 5 Humidifier connections 1/2" M
 - 6 Condensate drain with siphon
 - 7 Functional spaces
 - 8 Heating coil inlet H₂O ø 2"
 - 9 Heating coil outlet H₂O ø 2"
 - 10 Post-heating coil
 - 11 Treatment coil
 - 12 Heating coil H₂O
 - 13 Filters F7 - Filters F9 - Electrostatic filters
 - 14 Filters G4
 - 15 Electric fan (supply-return)
 - 16 -
- 17 Liften bracket (Removed)
 - 18 -
 - 19 -
 - 20 Coil-filters-heaters inspection
 - 21 -
 - 22 -
 - 23 Rotary recuperator
 - (R3) Downward air return
 - (M0) Horizontal air supply
 - (M3) Downward air supply
 - (M5) Vertical air supply
 - (AE) Outdoor air return (CBK / CBK-G / CCK-REVO version)
 - (H1) Wall with same height as unit on a maximum of three sides
 - (*) Vibration mounts position

SEZ A-A

		WEIGHT DISTRIBUTION		
Size		60.4	70.4	80.4
Version		CBK-G	CBK-G	CBK-G
W1	Support point	413	423	423
W2	Support point	495	506	506
W3	Support point	451	450	450
W4	Support point	409	419	419
W5	Support point	474	483	483
W6	Support point	363	362	362
	Operation weight	2605	2643	2643
	Shipping weight	2605	2643	2643

		GAS MODULE WEIGHT DISTRIBUTION		
Size		60.4 - 70.4	80.4	
W7	Support point	176	186.5	
W8	Support point	176	186.5	
W9	Support point	176	186.5	
W10	Support point	176	186.5	
	Operation weight	704	746	
	Shipping weight	704	746	

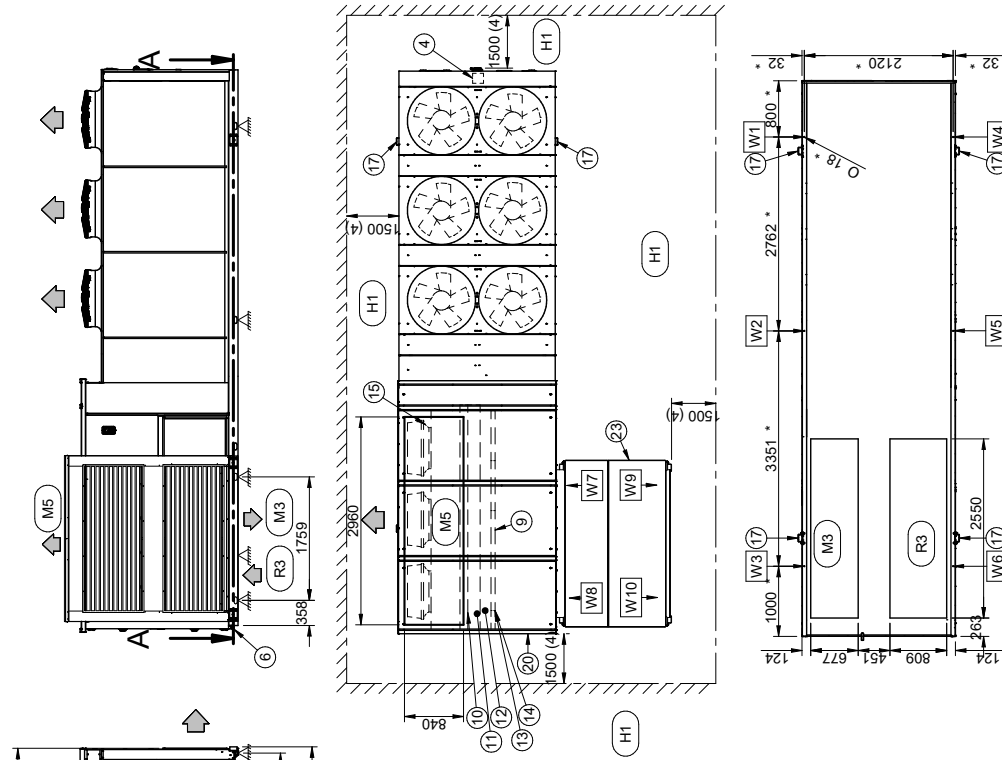

- 1 Compressor compartment
- 2 Electrical panel
- 3 Connector for keyboard or PC connection
- 4 Power input
- 5 Humidifier connections 1/2" M
- 6 Condensate drain with siphon
- 7 Functional spaces
- 8 Heating coil inlet H₂O ø 2"
- 9 Heating coil outlet H₂O ø 2"
- 10 Post-heating coil
- 11 Treatment coil
- 12 Heating coil H₂O
- 13 Filters F7 - Filters F9 - Electrostatic filters
- 14 Filters G4
- 15 Electric fan (supply-return)
- 16 -
- 17 Liftin bracket (Removed)
- 18 -
- 19 -
- 20 Coil-filters-heaters inspection
- 21 -
- 22 -
- 23 Rotary recuperator
- (R3) Downward air return
- (M0) Horizontal air supply
- (M3) Downward air supply
- (M5) Vertical air supply
- (AE) Outdoor air return (CBK / CBK-G / CCK-REVO version)
- (H1) Wall with same height as unit on a maximum of three sides
- (*) Vibration mounts position

WEIGHT DISTRIBUTION		90.4	100.4	120.4
Version		CBK-G	CBK-G	CBK-G
W1	Support point	Kg 569	Kg 569	Kg 640
W2	Support point	Kg 686	Kg 686	Kg 734
W3	Support point	Kg 582	Kg 582	Kg 576
W4	Support point	Kg 541	Kg 541	Kg 598
W5	Support point	Kg 691	Kg 691	Kg 740
W6	Support point	Kg 467	Kg 467	Kg 461
Operation weight		Kg 3536	Kg 3536	Kg 3750
Shipping weight		Kg 3536	Kg 3536	Kg 3750
Optional accessories may result in a substantial variation of the weight show in table				

GAS MODULE WEIGHT DISTRIBUTION		90.4	100.4 - 120.4
Size			
W7	Support point	Kg 196	Kg 204
W8	Support point	Kg 196	Kg 204
W9	Support point	Kg 196	Kg 204
W10	Support point	Kg 196	Kg 204
Operation weight		Kg 784	Kg 816
Shipping weight		Kg 784	Kg 816

FOR OVER 30 YEARS, WE HAVE BEEN
OFFERING SOLUTIONS TO ENSURE
SUSTAINABLE
COMFORT AND THE WELL-BEING OF PEOPLE
AND THE ENVIRONMENT

www.clivet.com

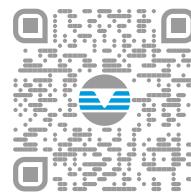

sales and assistance



CLIVET S.p.A.

Via Camp Lonc 25, Z.I. Villapaiera 32032 - Feltre (BL) - Italy

Tel. +39 0439 3131 - Fax +39 0439 313300

info@clivet.it

www.clivet.com

MideaGroup
humanizing technology