

*Air cooled reversible full inverter heat pump for outdoor installation*

# THUNDER

## WiSAN-P 14.1-30.2 RANGE

TECHNICAL BULLETIN



SIZE	14.1	16.1	18.1	19.1	20.1	25.2	30.2
Cooling capacity [kW]	34,9	38,5	49,9	54,0	58,2	67,8	72,7
Heating capacity kW	39,9	45,2	55,1	61,5	68,5	78,6	85,9

## Pagina

---

3	Features and benefits
5	R-290 refrigerant
7	Standard unit technical specifications
9	Unit configuration
10	Built-in options
11	Options supplied separately
14	General technical data
24	Performances
56	Features and options
60	Modularity and management of cascade units
63	Management of auxiliary heat sources
65	Dimensional drawings



Clivet participates in the ECP Programme for "Liquid Chillers and Hydronic Heat Pumps".  
Check ongoing validity of certificate on [www.eurovent-certification.com](http://www.eurovent-certification.com)"

# Features and benefits

---

THUNDER is the new air-cooled heat pump with full DC inverter technology and R290 refrigerant with ultra-low GWP, suitable for outdoor installation.

---

## WiSAN-P

Air cooled heat pump with Full DC Inverter technology and R-290 refrigerant

- Range 34,9 ÷ 85,9 kW
- Seasonal heating efficiency (SCOP) up to 4,70 for Low temperature applications (W35), up to 3,63 for Medium temperature applications (W55)
- Seasonal cooling efficiency (SEER) up to 5,47
- Operating with 48°C of outdoor air temperature in cooling
- Operating down to -20°C of outdoor air temperature in heating
- Hot water production up to 75°C
- Copper/aluminum condensing coil
- Plate exchanger
- 1 refrigeration circuit



The THUNDER range is available from 34,9 kW to 85,9 kW and, thanks to its high seasonal efficiency and extended operating range, it is the perfect solution for applications in replacement of existing generators, as well as in new installations, both for all year round room heating and domestic hot water production.

## Energy Efficiency

**SCOP** up to 4,70 (W35) / **SCOP** up to 3,63 (W55)  
**SEER** up to 5,47 (W7)

Capacity modulation from 30% to 100%.

## Wide operating range

<b>Outdoor temperature</b>	<b>Max</b>	<b>Min</b>
Heating	42°C	-20°C
Domestic hot water	42°C	-20°C
Cooling	48°C	-10°C

<b>Water temperature produced by the unit</b>	<b>Max</b>	<b>Min</b>
Heating	75°C	25°C
Domestic hot water	75°C	25°C
Cooling	20°C	0°C

The maximum DHW set-point that can be set is 5°C lower than the maximum set-point that the unit can achieve, to account for heat exchange through the DHW coil or the DHW exchanger installed and sized by the customer.

## Functionality

- Management and production of domestic hot water
- Climatic compensation with external temperature
- Double set-point management
- Auxiliary generator management
- SG Ready
- EVU lock ready (remote on/off)
- Demand limit
- Standard supplied energy monitoring function

## Acoustic configuration

Three sound configurations levels of silence:

- Acoustic configuration with compressor soundproofing (SC)
- Silenced acoustic configuration - LN from -2 to -4 dB(A) compared to the SC version
- Super-silenced acoustic configuration - EN from -6 to -10 dB(A) compared to the SC version.

## Application Versatility

All the main system components are integrated in the unit, assuring the best reliability and an easy installation:

- Hydronic assembly with 1 inverter pump
- Hydronic assembly with 1+1 inverter pump (one in operation and one in back-up)
- 3-way valve for the domestic hot water production
- System storage tank: 150 litres size 14.1 ÷ 20.1), 240 litres size 25.2 ÷ 30.2)
- Standard Drain-tray with electric heater

## Cascade management

THUNDER is designed to connect up to 16 units in a local area network, reaching a maximum unit capacity of 1360 kW. The maximum number of unit hydraulically connected is 6, according to water piping sizing. Combinations can also include units with a different capacity.

# R-290 refrigerant

## Characteristics of R-290 refrigerant (Propane)

The unit contains R290 refrigerant gas [Propane]

According to Directive 2014/68/EU [PED], the substance is classified as a Class 1 gas (hazardous fluids). According to EN 378-1:2020, this refrigerant is classified as a Class A3 substance (low toxicity, high flammability).

### Main characteristics:

- Colourless
- Odourless
- Highly flammable
- Heavier than air (stratifies at the bottom)

### Physical characteristics:

Characteristic	Value	Unit / Notes
Safety class (ISO 817)	A3	Highly flammable
GWP (Global warming potential)	3	100 yr
ODP (Ozone layer depletion)	0	
LFL	0.038	kg/m <sup>3</sup>
Lower flammability limit	2.1	% Vol
Boiling point	-42	°C
Self-ignition temperature	470	°C
Density (T=20°C; p=1 bar(a))	1.86	kg/m <sup>3</sup>
Air density (T=20°C; p=1 bar(a))	1.55	

### Ignition sources

Due to the highly flammable nature of the refrigerant, a leak can cause an explosive atmosphere upon contact with air. Any source that could potentially ignite such an atmosphere must be kept outside the safety area.

A non-exhaustive list is as follows:

- Naked flames, cigarettes
- Electrical sockets, switches, lights
- Electrical and electronic devices that are not ignition-proof, including battery devices
- Electrostatic charges
- Hot surfaces above 370°C

Access category	Max. permissible R-290 charge	Unit
a – generic	< 5 Kg	WiSAN-P 14.1 WiSAN-P 16.1 WiSAN-P 18.1 WiSAN-P 19.1 WiSAN-P 20.1
b – supervised / limited	< 10 Kg	WiSAN-P 25.2 WiSAN-P 30.2
c - authorised	> 10 Kg	-

## Safety measures on the unit

### Leak sensor:

- The leak sensor has an automatic recalibration phase, recognising any background noise
- the unit is fitted with 2 leak sensors
- when the unit is powered, the sensors are active and monitor the atmosphere within the refrigerant circuit and in the electrical panel
- the sensor signals an alarm if the R290 (Propane) concentration exceeds 25% of the LFL
- when the alarm is triggered, the unit switches off and a dedicated exhaust fan is activated to dispel the potential explosive atmosphere
- an alarm with manual reset is displayed on the wired controller

⚠ If the unit is not powered, the leak detection system is not active.

⚠ The unit sensor does not replace the personal leak detector.

### Exhaust fan:

- the unit has an ATEX exhaust fan
- this fan dispels the atmosphere inside the refrigerant circuit box
- when the unit is switched on and the leak sensor signals an alarm, the fan is switched on until the explosive atmosphere is dissipated

⚠ The flammable atmosphere will be ejected into the room in the fan's air flow direction.

⚠ The fan must not be ducted in any other way than by the manufacturer.

### Pre-ventilation selector switch:

- the unit has a pre-ventilation selector switch
- when the selector switch is activated, the exhaust fan switches on, cleaning the refrigerant circuit box from a potential explosive atmosphere

### Degasser / Deaerator:

- the unit is shipped without a degasser
- the installation of an automatic air purge system in the water circuit is mandatory
- the installation prevents the release of refrigerant in the building in the event of a water heat exchanger fault (e.g. due to freezing, corrosion, etc.)
- the purged air must be vented or ducted outside any building away from potential ignition sources

⚠ The air purge system must be the only one to open automatically in the entire system.

⚠ Any other purge system must be closed or ducted to the outside to prevent the release of refrigerant in the building.

### Water side pressure relief valve:

- the unit is fitted with a water pressure relief valve
- the installation prevents the release of refrigerant in the building in the event of a water heat exchanger fault (e.g. due to freezing, corrosion, etc.)
- the water pressure relief valve must be installed or ducted outside any building away from potential ignition sources

⚠ The water pressure relief valve must be the only one to open automatically in the entire system.

⚠ Any other water pressure relief valve must be calibrated to a higher pressure value or ducted to the outside to prevent the release of refrigerant in the building.

# Standard unit technical specifications

## Compressor

### Sizes 14.1-20.1

Inverter-controlled scroll hermetic compressor fitted with a motor protection device for overheating, overcurrents and excessive temperatures of the supply gas. It is installed on rubber antivibration mounts and is complete with oil charge. A crankcase heater with automatic activation prevents the refrigerant from diluting the oil when the compressor stops.

### Size 25.2 - 30.2

Inverter-controlled scroll hermetic compressors fitted with a motor protection device for overheating, overcurrents and excessive temperatures of the supply gas. They are installed on rubber antivibration mounts and are complete with oil charge. An oil heater with automatic activation prevents the refrigerant from diluting the oil when the compressor stops.

The compressors are connected in tandem on a single refrigeration circuit.

## Structure

Supporting structure made of steel frame with Zinc-Magnesium surface treatment painted with RAL 9001 polyester powder, that ensures excellent mechanical features and high long-term resistance against corrosion.

The structure incorporates a drain pan made of steel with Zinc-Magnesium surface treatment painted with RAL 9001 polyester powder to collect and drain condensate.

The drain pan underneath the coils has Mylar electric antifreeze heaters fitted on the bottom and a drain on the rear part, water fittings side. The electric heaters are thermostatically controlled and switch on according to the ambient temperature ( $T_a < +5^\circ\text{C}$ ).

## Panelling

RAL 9001 painted zinc-magnesium sheet metal external panelling that ensures superior resistance to corrosion in outdoor installations and eliminates the need for periodic painting. Each panel can be easily removed to allow full access to internal components. The refrigeration circuit panelling is fitted with 20 mm polyester fibre acoustic insulation.

## Internal exchanger

Direct expansion heat exchanger, braze-welded AISI 316 stainless steel plates, in pack without seals using copper as the brazing material, with low refrigerant charge and large exchange surface, complete with:

- 17 mm thick thermal insulation made of sintered expanded polypropylene;
- antifreeze probe temperature;
- antifreeze heaters to protect the water side exchanger to prevent ice from forming if the water temperature drops below the pre-set value.

## External exchanger

Finned coil direct expansion exchanger made from copper pipes arranged in staggered rows and mechanically expanded to better adhere to the fin collar. The fins are made from aluminium with a hydrophilic coating to ensure correct evacuation of the condensate water, and have a special corrugated surface, appropriately distanced to ensure the maximum heat exchange efficiency.

## Fan

Helical fans with reinforced plastic profiled blades, directly coupled to an electronically controlled brushless DC motor, IP 54 version. Housed in aerodynamically shaped nozzles to increase efficiency and minimise noise levels, they are fitted with safety grilles.

## Refrigeration circuit

Refrigerant circuit complete with:

- mechanical filters and drier;
- liquid receiver;
- pressure transducers (high and low pressure);
- refrigerant temperature probe;
- electronic expansion valve;
- 4-way cycle inversion valve;
- high pressure safety pressure switch (pressurised safety chain PL=d);
- ductable low pressure relief valve;
- liquid separator in extraction;
- safety thermostat against compressor drain overheating;
- primary refrigeration circuit leak detector;
- ATEX emergency exhaust fan.

## Electrical panel

- auxiliary component protection fuses;
- compressor protection fuses;
- fan motor circuit breakers;
- phase monitor;
- Secondary electrical panel leak detector;
- electrical panel air cooling system;
- interface terminal with graphic display;
- intuitive graphical interface retro lighted;
- display of operating data;
- machine ON/OFF and protection devices reset;
- heating/cooling operating mode manual change;
- display and modification of functional parameters;
- temperature set point and unit switch-on/off daily, weekly programmer;
- self-diagnosis system with instant error code visualisation;
- compressor overload protection and timer;
- relay for remote cumulative fault signal;
- dry contact for remote on-off control;
- dry contact for summer / winter change;
- dry contacts for compressor status;
- double set-point;
- set-point compensation based on outdoor air;
- set-point modification via 0-10V or 4...20mA signal;
- demand limit via 0-10V or 4...20mA signal;
- SG Ready contact,
- Silent mode contact;
- serial port with Modbus outlet (RS 485) for remote communication;
- 3-way valve control provision for DHW;
- inverter pump control provision.

## Water circuit

- safety valve 6 ba
- flow switch;
- drain valve;
- temperature sensors;
- relief valve.

## Test

Unit subjected to factory-tested in specific steps and test pressure of the piping of the refrigerant circuit (with nitrogen and hydrogen), before shipping them.

The unit will be shipped with R290 refrigerant charge.

## Unit equipment with outdoor air low temperatures

MINIMUM OUTDOOR AIR TEMPERATURE		OPERATING UNIT		UNIT IN STAND-BY <sup>(5)</sup> (fed unit)	UNIT IN STORAGE (unit not fed)
		COOL*	HOT**		
+11°C	1	✓ STANDARD UNIT			
+2°C	2				
-5°C	4				
-7°C	3				
-10°C	4			✓ STANDARD UNIT	✓ WATER EMPTY UNIT OR WITH AN APPROPRIATE GLYCOL PERCENTAGE
Between -10°C and -15°C			✓ STANDARD UNIT		
From -15°C to -20°C		NOT POSSIBLE		✓ WATER EMPTY UNIT OR WITH AN APPROPRIATE GLYCOL PERCENTAGE	NOT POSSIBLE
From -20°C to -30°C			NOT POSSIBLE	✓ WATER EMPTY UNIT OR WITH AN APPROPRIATE GLYCOL PERCENTAGE ✓ PUMPS WITH REGULATION ON BOARD INVERTER	

Data referred to the following conditions:

\*chilled water production:

cold side exchanger water = 12/7°C

\*\*hot water production:

internal exchanger water = 30/35 °C

1. Part load unit and air speed equal to 1 m/s.
2. Part load unit and air speed equal to 0.5 m/s.
3. Part load unit and outdoor air temperature at rest.
4. Full load unit and outdoor air temperature at rest.

<sup>(5)</sup> The water pumping unit must be fed and connected to the unit according to the manual.

<sup>(6)</sup> Unit without water or containing water with an appropriate quantity of glycol.

At the unit start-up the water temperature or water with glycol must be inside the operating range indicated in the "Operating range" graph.

To know the water freezing temperature on varying the glycol percentage refer to the specific 'Correction factors for glycol use' table.

⚠ Air conditions which are at rest are defined as the absence of air flowing towards the unit. Weak winds can induce air to flow through the exchanger and air-levels which can cause a reduction in the operating range.

In the presence of predominant winds it is necessary to use suitable windbreak barriers.

⚠ The unit, with an outdoor air temperature on average lower than -10°C, can remain stored for a maximum of 1 month.

# Unit configuration

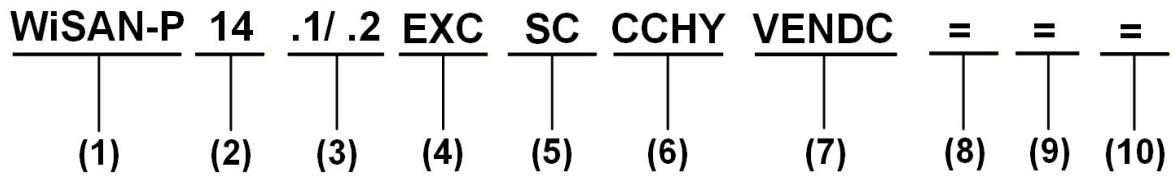

## (1) Range

WiSAN-P - Full inverter reversible air-water heat pump with R-290 refrigerant

## (2) Size

14 = Nominal compressor capacity (HP)

## (3) Compressors

.1/.2 = Compressor quantity

## (4) Energy version

EXC = Excellence version (Standard)

## (5) Acoustic configuration

SC = Acoustic configuration with compressor soundproofing (Standard)

LN = Silenced acoustic configuration

EN = Super-Silenced acoustic configuration

## (6) Condensing coil

CCHY = Copper / aluminium condenser coil with hydrophilic treatment (Standard)

CCCA = Copper / aluminium condenser coil with acrylic lining

CCCA1 = Copper / aluminium condensing coils with Aluminium Energy Guard DCC treatment

## (7) Fans

VENDC = DC high efficiency fan (Standard)

## (8) Pumping unit

(-) Not required (standard)

HYGU1VI = User side hydronic assembly with 1 inverter pumps

1+1HYGU1VI = User side hydronic assembly with 1+1 Inverter pump

## (9) Storage tank

(-) Not required (standard)

ACIMP = Stainless steel inertial system storage tank

## (10) Domestic hot water valve

(-) Not required (standard)

3DHW = 3-way valve for domestic hot water mounted on board

## ACIMP

### Stainless steel inertial system storage tank

Steel storage tank complete with double layer covering with closed-cell insulation, stainless steel anti-freeze immersion resistance, bleed valve, draw off cock, cast-iron shut-off butterfly valve with quick connections and activation lever with a mechanical calibration lock at the evaporator output, quick connections with insulated casing.

The water tank capacity is 150 litres for sizes 14.1, 16.1, 18.1, 19.1, 20.1.

The water tank capacity is 240 litres for sizes 25.2, 30.2.

## 3DHW

### 3-way valve for domestic hot water mounted on board

The switching valve for switching the water flow to a domestic water heating tank is installed on the unit. If the DHW temperature falls below the set-point, THUNDER switches to DHW production mode (priority over other operating modes can be set). The machine controller closes a digital output driving the flow switching valve from the system to the water tank until it reaches the ACS set-point set on the user interface.

The water connections are 2" Victaulic.

⚠ The maximum DHW set-point that can be set is 5°C lower than the maximum set point that the unit can achieve, to account for heat exchange through the DHW coil or the DHW exchanger installed and sized by the customer.

### DHW switching valve pressure drops

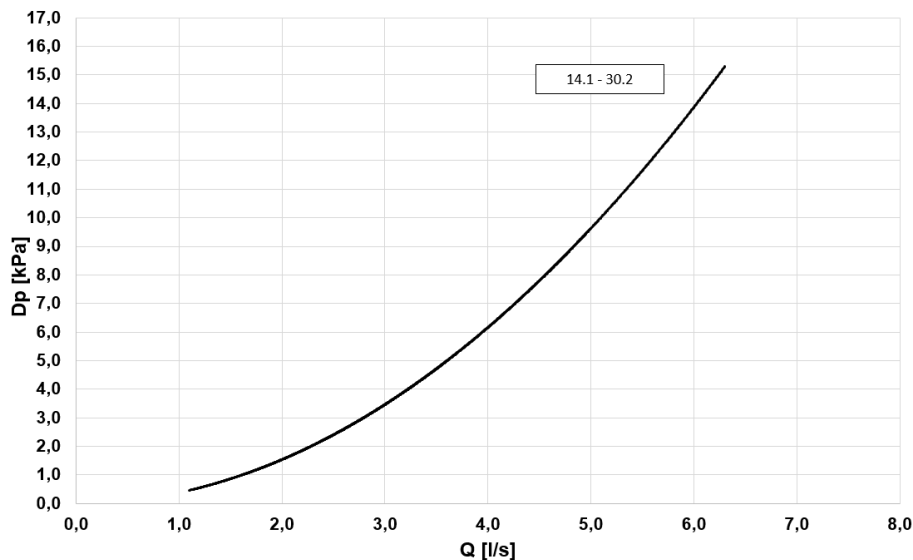

Q = Water flow-rate[l/s]

Dp = Water side pressure drops [kPa]

⚠ The maximum nominal pressure of the unit with the 3-way valve option is 6 bar

## CCCA

### Copper/aluminium condenser coil with acrylic lining

Coils with copper pipes and aluminium fins with acrylic coating. They can be used in environments containing airborne concentrations of salt and other moderately aggressive agents.

The treatment entails:

Cooling capacity variation -2.7%.

Compressor power input variation +4.2%.

Operating range reduction -2.1°C.

## CCCA1

### Condenser coil with Energy Guard DCC Aluminum

This treatment provides excellent and guaranteed thermal exchange over time and protects finned coil exchangers from corrosion. They can be used in environments containing airborne concentrations of salt and other very aggressive chemicals while maintaining coil performance over time.

## PGFC

### Finned coil protection grilles

The grilles protect the external coil from accidental contact with objects or persons. Ideal for installation in places where persons can pass from, such as car parks, terraces, etc.

# Options supplied separately

## IFWX

### Steel mesh strainer on the water side

The device stops the exchanger from being clogged by any impurities which are in the hydraulic circuit. The mechanical steel mesh strainer must be placed on the water input line. It can be easily dismantled for periodical maintenance and cleaning.

Filter fittings are Victaulic type by 2"

### Steel mesh strainer pressure drops

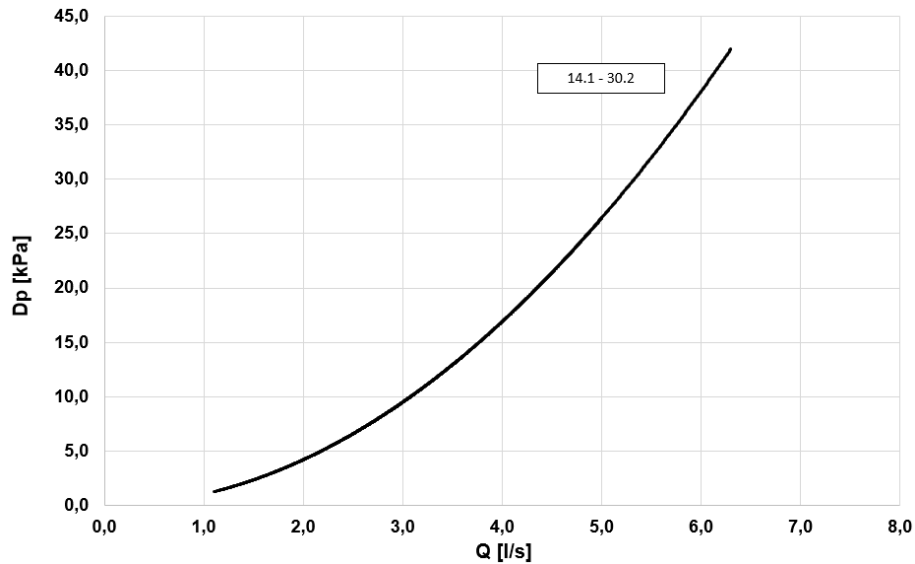

Q = Water flow-rate[l/s]

Dp = Water side pressure drops [kPa]

## AVIBX

### Anti-vibration mount support

The rubber antivibration mounts are attached in special housings on the support frame and serve to smooth the vibrations produced by the unit, thus reducing the noise transmitted to the support structure.

## PGFCX

### Finned coil protection grilles

The grilles protect the external coil from accidental contact with objects or people.

Ideal for installation in places where persons can pass from, such as car parks, terraces, etc.

## AMODX

### Water connections for modular unit

To configure a modular system, each unit must be selected with the water connections for a modular unit. The kit consists of 2 4" manifolds placed horizontally and 2 butterfly valves that make it possible to exclude the unit from the modular system in case of failure. The water outlets remain in the same position as the single unit, only the piping diameters vary, which are 4".

## CCKMUX

### Kit containing pipe closing caps for modular units

Option for modular system connection.

## AMMSX Anti-seismic spring antivibration mounts

The anti-seismic spring antivibration mounts are to be attached in special housings on the support frame. The containment structure is designed to ensure high resistance to multi-directional forces acting on the surface of the hanging unit in case of wind and/or earthquakes.

The antivibration mounts have been tested according to ANSI/ASHRAE 171-2008 standard (Method of Testing Seismic Restraint devices for HVAC&R Equipment). The performance levels and the test methodology have been validated and certified by Lloyd's Register.

⚠ Installation is a responsibility of the Customer.

## 3DHWX DHW switching valve

The switching valve for switching the water flow to a domestic water heating tank is installed on the unit. If the DHW temperature falls below the set-point, the unit switches to DHW production mode (priority over other operating modes can be set). The machine controller closes a digital output driving the flow switching valve from the system to the water tank until it reaches the ACS set-point set on the user interface. The water connections are 2" Victaulic.

⚠ The maximum DHW set-point that can be set is 5°C lower than the maximum set point that the unit can achieve, to account for heat exchange through the DHW coil or the DHW exchanger installed and sized by the customer.

### DHW switching valve pressure drops

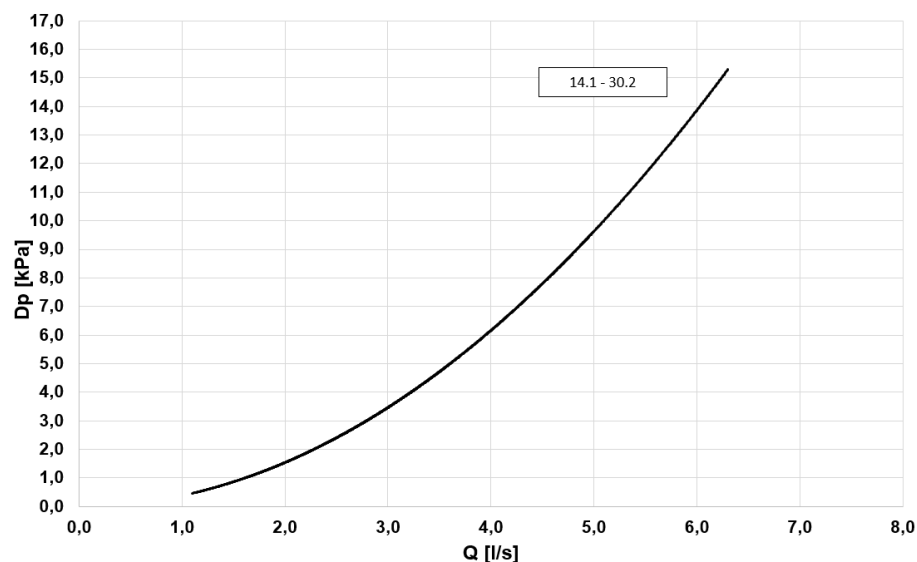

Q = Water flow-rate[l/s]

Dp = Water side pressure drops [kPa]

⚠ The maximum nominal pressure of the unit with the 3-way valve option is 6 bar

## VSAX Automatic purge valve

The deaerator is used to continuously eliminate air or refrigerant from the hydraulic circuits of air conditioning systems. The discharge capacity of this device is extremely high, eliminating at least 95% of air (or refrigerant) in the circuits, down to the micro-bubbles, automatically with very low pressure drops. The deaerator is installed, by the Customer, near the unit and outside the building. It is positioned on the return water line at the unit outlet.



# Options supplied separately

## IOTX

### IoT industrial module for cloud based interoperability & services

This device allows the monitoring and the remote control the unit via Clivet Eye, the supervision cloud system for Clivet units.

With IoT module (i-LINK) it will be possible to monitor and manage the unit through the mobile app Clivet Eye and the dedicated web page.

Among the main functions, for all monitored units they allow to:

- display the main working parameters;
- display the alarms;
- switch on/off the unit;
- change the setpoint;
- change the operating mode;
- set the daily/weekly start-up or power-off programming of the unit;
- create charts of main system parameters trend (via web interface);
- display in a map the units monitored by Clivet Eye (via web interface).

Web interface at [www.cliveteye.com](http://www.cliveteye.com).

Clivet Eye app available in Google Play and Apple Store



- ⚠ IoT module to be provided for each unit to be remotely monitored.
- ⚠ Internet ethernet connection in charge of customer.
- ⚠ Clivet Eye management is alternative to an external BMS supervision system.
- ⚠ Installation is a responsibility of the Customer.

## Performance - Acoustic configuration with compressor soundproofing (SC)

SIZE			14.1	16.1	18.1	19.1	20.1	25.2	30.2
<b>Radiant panels</b>									
<b>Heating</b>									
Heating capacity (EN 14511:2022)	1,8	kW	40,1	46,8	50,4	55,8	61,0	70,2	84,4
COP (EN 14511:2022)	2	-	3,92	3,71	3,81	3,78	3,73	3,91	3,74
ErP Space Heating Energy Class - AVERAGE Climate - W35	7	-	A+++	A+++	A++	A++	A++	A+++	A+++
SCOP - MEDIUM Climate - W35	9	-	4,51	4,45	4,36	4,29	4,22	4,70	4,54
$\eta_{s,h}$ - MEDIUM climate - W35	10	%	177	175	171	169	166	185	179
<b>Cooling</b>									
Cooling capacity (EN 14511:2022)	4,8	kW	42,6	46,8	55,6	59,7	64,7	79,9	86,1
EER (EN 14511:2022)	5	-	4,28	3,99	3,66	3,63	3,41	4,23	3,90
Water flow-rate	4	l/s	2,04	2,24	2,66	2,86	3,09	3,82	4,12
User side exchanger pressure drops	4	kPa	11,9	14,1	11,7	13,3	15,5	18,8	21,6
<b>Terminal units</b>									
<b>Heating</b>									
Heating capacity (EN 14511:2022)	3	kW	39,9	45,2	55,1	61,5	68,5	78,6	85,9
COP (EN 14511:2022)	2	-	3,11	3,08	3,19	3,13	2,92	3,14	3,01
<b>Cooling</b>									
Cooling capacity (EN 14511:2022)	6	kW	34,9	38,5	49,9	54,0	58,2	67,8	72,7
EER (EN 14511:2022)	5	-	2,84	2,81	2,58	2,46	2,35	2,86	2,64
SEER	9	-	5,36	5,20	4,73	4,58	4,36	5,47	5,3
$\eta_{s,c}$	11	%	211	205	186	180	171	216	209
Water flow-rate	6	l/s	1,66	1,83	2,37	2,57	2,77	3,22	3,46
User side exchanger pressure drops	6	kPa	8,27	9,86	9,44	10,9	12,6	13,8	15,7
<b>Radiators</b>									
<b>Heating</b>									
Heating capacity (EN 14511:2022)	12	kW	37,0	42,9	47,4	51,2	55,7	65,9	76,6
COP (EN 14511:2022)	2	-	2,71	2,57	2,67	2,60	2,55	2,74	2,56
ErP Space Heating Energy Class - AVERAGE Climate - W55	7	-	A++	A++	A++	A++	A++	A++	A++
SCOP - MEDIUM Climate - W55	9	-	3,54	3,51	3,51	3,47	3,41	3,63	3,60
$\eta_{s,h}$ - MEDIUM Climate - W55	10	%	139	137	137	136	133	142	141

The Product is compliant with the ErP (Energy Related Products) European Directive. It includes the Commission delegated Regulation (EU) No 811/2013 (rated heat output  $\leq 70$  kW at specified reference conditions) and the Commission delegated Regulation (EU) No 813/2013 (rated heat output  $\leq 400$  kW at specified reference conditions)  
Contains natural gas (GWP 3)

1. Entering/leaving water temperature user side 30/35 °C, Entering external exchanger air temperature 7 °C (R.H. = 85%)
2. COP (EN 14511:2022) Heating performance coefficient. Ratio between delivered heating capacity and power input in compliance with EN 14511:2022. The overall power absorbed is calculated by adding the power absorbed by the compressor + the power absorbed by the fan - the percentage value of the fan to overcome external pressure drop + the power absorbed by the pump - the percentage value of the pump to overcome pressure drop outside + the power absorbed by the auxiliary electrical circuit.
3. Entering/leaving water temperature user side 40/45 °C, Entering external exchanger air temperature 7 °C (R.H. = 85%)
4. Entering/leaving water temperature user side 23/18 °C, Entering external exchanger air temperature 35 °C
5. EER (EN 14511:2022) cooling performance coefficient. Ratio between delivered cooling capacity and power input in compliance with EN 14511:2022. The overall power absorbed is calculated by adding the power absorbed by the compressor + the power absorbed by the fan - the percentage value of the fan to overcome external pressure drop + the power absorbed by the pump - the percentage value of the pump to overcome pressure drop outside + the power absorbed by the auxiliary electrical circuit.
6. Entering/leaving water temperature user side 12/7 °C, Entering external exchanger air temperature 35 °C
7. Seasonal Space Heating Energy Efficiency Class according to Commission delegated Regulation (EU) No 811/2013. W = Water outlet temperature (°C)
8. The data refers to the unit operating with optimized inverter frequency
9. Data calculated in compliance with EN 14825:2022.
10. Seasonal energy efficiency in heating EN 14825:2022.
11. Seasonal energy efficiency in cooling EN 14825:2022.
12. Entering/leaving water temperature user side 50/55 °C, Entering external exchanger air temperature 7 °C (R.H. = 85%)

# General technical data

## Performance - Silenced acoustic configuration (LN)

SIZE			14.1	16.1	18.1	19.1	20.1	25.2	30.2
<b>Radiant panels</b>									
<b>Heating</b>									
Heating capacity (EN 14511:2022)	1,8	kW	35,1	40,9	44,0	48,8	53,3	61,4	73,7
COP (EN 14511:2022)	2	-	3,86	3,65	3,74	3,71	3,66	3,84	3,67
ErP Space Heating Energy Class - AVERAGE Climate - W35	7	-	A+++	A+++	A++	A++	A++	A+++	A+++
SCOP - MEDIUM Climate - W35	9	-	4,51	4,45	4,36	4,29	4,22	4,70	4,54
$\eta_{s,h}$ - MEDIUM climate - W35	10	%	177	175	171	169	166	185	179
<b>Cooling</b>									
Cooling capacity (EN 14511:2022)	4,8	kW	37,2	40,9	50,6	52,2	56,6	69,8	75,2
EER (EN 14511:2022)	5	-	4,21	3,91	3,62	3,61	3,35	4,16	3,83
Water flow-rate	4	l/s	1,78	1,95	2,42	2,50	2,70	3,34	3,60
User side exchanger pressure drops	4	kPa	9,38	11,1	9,77	10,4	12,0	14,7	16,8
<b>Terminal units</b>									
<b>Heating</b>									
Heating capacity (EN 14511:2022)	3	kW	37,0	39,5	48,1	53,8	59,8	68,7	75,1
COP (EN 14511:2022)	2	-	3,15	3,05	3,13	3,07	2,87	3,09	2,96
<b>Cooling</b>									
Cooling capacity (EN 14511:2022)	6	kW	32,4	33,6	44,9	47,9	50,9	59,3	63,5
EER (EN 14511:2022)	5	-	2,87	2,78	2,60	2,41	2,31	2,81	2,59
SEER	9	-	5,30	5,08	4,66	4,49	4,27	5,35	5,19
$\eta_{s,c}$	11	%	209	200	184	177	168	211	205
Water flow-rate	6	l/s	1,54	1,60	2,14	2,28	2,42	2,82	3,02
User side exchanger pressure drops	6	kPa	7,24	7,74	7,76	8,75	9,78	10,8	12,2
<b>Radiators</b>									
<b>Heating</b>									
Heating capacity (EN 14511:2022)	12	kW	32,3	37,5	41,4	44,8	48,7	57,6	66,9
COP (EN 14511:2022)	2	-	2,66	2,52	2,62	2,55	2,50	2,69	2,51
ErP Space Heating Energy Class - AVERAGE Climate - W55	7	-	A++	A++	A++	A++	A++	A++	A++
SCOP - MEDIUM Climate - W55	9	-	3,54	3,51	3,51	3,47	3,41	3,63	3,60
$\eta_{s,h}$ - MEDIUM Climate - W55	10	%	139	137	137	136	133	142	141

The Product is compliant with the ErP (Energy Related Products) European Directive. It includes the Commission delegated Regulation (EU) No 811/2013 (rated heat output  $\leq 70$  kW at specified reference conditions) and the Commission delegated Regulation (EU) No 813/2013 (rated heat output  $\leq 400$  kW at specified reference conditions)  
Contains fluorinated greenhouse gases (GWP 675)

1. Entering/leaving water temperature user side 30/35 °C, Entering external exchanger air temperature 7 °C (R.H. = 85%)
2. COP (EN 14511:2022) Heating performance coefficient. Ratio between delivered heating capacity and power input in compliance with EN 14511:2022. The overall power absorbed is calculated by adding the power absorbed by the compressor + the power absorbed by the fan - the percentage value of the fan to overcome external pressure drop + the power absorbed by the pump - the percentage value of the pump to overcome pressure drop outside + the power absorbed by the auxiliary electrical circuit.
3. Entering/leaving water temperature user side 40/45 °C, Entering external exchanger air temperature 7 °C (R.H. = 85%)
4. Entering/leaving water temperature user side 23/18 °C, Entering external exchanger air temperature 35 °C
5. EER (EN 14511:2022) cooling performance coefficient. Ratio between delivered cooling capacity and power input in compliance with EN 14511:2022. The overall power absorbed is calculated by adding the power absorbed by the compressor + the power absorbed by the fan - the percentage value of the fan to overcome external pressure drop + the power absorbed by the pump - the percentage value of the pump to overcome pressure drop outside + the power absorbed by the auxiliary electrical circuit.
6. Entering/leaving water temperature user side 12/7 °C, Entering external exchanger air temperature 35 °C
7. Seasonal Space Heating Energy Efficiency Class according to Commission delegated Regulation (EU) No 811/2013. W = Water outlet temperature (°C)
8. The data refers to the unit operating with optimized inverter frequency
9. Data calculated in compliance with EN 14825:2022.
10. Seasonal energy efficiency in heating EN 14825:2022.
11. Seasonal energy efficiency in cooling EN 14825:2022.
12. Entering/leaving water temperature user side 50/55 °C, Entering external exchanger air temperature 7 °C (R.H. = 85%)

## Performance - Super-Silenced acoustic configuration (EN)

SIZE			14.1	16.1	18.1	19.1	20.1	25.2	30.2
<b>Radiant panels</b>									
<b>Heating</b>									
Heating capacity (EN 14511:2022)	1,8	kW	29,2	34,1	36,7	40,6	44,4	51,1	61,4
COP (EN 14511:2022)	2	-	3,93	3,73	3,82	3,79	3,74	3,92	3,76
ErP Space Heating Energy Class - AVERAGE Climate - W35	7	-	A+++	A+++	A++	A++	A++	A+++	A+++
SCOP - MEDIUM Climate - W35	9	-	4,51	4,45	4,36	4,29	4,22	4,70	4,54
$\eta_{s,h}$ - MEDIUM climate - W35	10	%	177	175	171	169	166	185	179
<b>Cooling</b>									
Cooling capacity (EN 14511:2022)	4,8	kW	31,0	34,1	42,1	43,5	47,1	58,2	62,7
EER (EN 14511:2022)	5	-	4,30	4,00	3,70	3,69	3,42	4,25	3,92
Water flow-rate	4	l/s	1,48	1,63	2,01	2,08	2,25	2,78	3,00
User side exchanger pressure drops	4	kPa	6,77	8,01	6,96	7,39	8,58	10,5	12,1
<b>Terminal units</b>									
<b>Heating</b>									
Heating capacity (EN 14511:2022)	3	kW	30,8	32,9	40,1	44,8	49,9	57,2	62,5
COP (EN 14511:2022)	2	-	3,21	3,11	3,20	3,14	2,93	3,15	3,02
<b>Cooling</b>									
Cooling capacity (EN 14511:2022)	6	kW	27,0	28,0	37,4	39,9	42,4	49,4	53,0
EER (EN 14511:2022)	5	-	2,94	2,84	2,66	2,46	2,36	2,87	2,65
SEER	9	-	5,33	5,16	4,73	4,61	4,41	5,42	5,26
$\eta_{s,c}$	11	%	210	204	186	181	174	214	207
Water flow-rate	6	l/s	1,28	1,33	1,78	1,90	2,01	2,35	2,52
User side exchanger pressure drops	6	kPa	5,22	5,59	5,53	6,24	6,97	7,71	8,76
<b>Radiators</b>									
<b>Heating</b>									
Heating capacity (EN 14511:2022)	12	kW	26,9	31,2	34,5	37,3	40,6	48,0	55,7
COP (EN 14511:2022)	2	-	2,71	2,57	2,68	2,61	2,56	2,74	2,57
ErP Space Heating Energy Class - AVERAGE Climate - W55	7	-	A++	A++	A++	A++	A++	A++	A++
SCOP - MEDIUM Climate - W55	9	-	3,54	3,51	3,51	3,47	3,41	3,63	3,60
$\eta_{s,h}$ - MEDIUM Climate - W55	10	%	139	137	137	136	133	142	141

The Product is compliant with the ErP (Energy Related Products) European Directive. It includes the Commission delegated Regulation (EU) No 811/2013 (rated heat output  $\leq 70$  kW at specified reference conditions) and the Commission delegated Regulation (EU) No 813/2013 (rated heat output  $\leq 400$  kW at specified reference conditions)  
Contains fluorinated greenhouse gases (GWP 675)

1. Entering/leaving water temperature user side 30/35 °C, Entering external exchanger air temperature 7 °C (R.H. = 85%)
2. COP (EN 14511:2022) Heating performance coefficient. Ratio between delivered heating capacity and power input in compliance with EN 14511:2022. The overall power absorbed is calculated by adding the power absorbed by the compressor + the power absorbed by the fan - the percentage value of the fan to overcome external pressure drop + the power absorbed by the pump - the percentage value of the pump to overcome pressure drop outside + the power absorbed by the auxiliary electrical circuit.
3. Entering/leaving water temperature user side 40/45 °C, Entering external exchanger air temperature 7 °C (R.H. = 85%)
4. Entering/leaving water temperature user side 23/18 °C, Entering external exchanger air temperature 35 °C
5. EER (EN 14511:2022) cooling performance coefficient. Ratio between delivered cooling capacity and power input in compliance with EN 14511:2022. The overall power absorbed is calculated by adding the power absorbed by the compressor + the power absorbed by the fan - the percentage value of the fan to overcome external pressure drop + the power absorbed by the pump - the percentage value of the pump to overcome pressure drop outside + the power absorbed by the auxiliary electrical circuit.
6. Entering/leaving water temperature user side 12/7 °C, Entering external exchanger air temperature 35 °C
7. Seasonal Space Heating Energy Efficiency Class according to Commission delegated Regulation (EU) No 811/2013. W = Water outlet temperature (°C)
8. The data refers to the unit operating with optimized inverter frequency
9. Data calculated in compliance with EN 14825:2022.
10. Seasonal energy efficiency in heating EN 14825:2022.
11. Seasonal energy efficiency in cooling EN 14825:2022.
12. Entering/leaving water temperature user side 50/55 °C, Entering external exchanger air temperature 7 °C (R.H. = 85%)

# General technical data

## Construction

SIZE		14.1	16.1	18.1	19.1	20.1	25.2	30.2
<b>Compressor</b>								
Type of compressors		SCROLL INVERTER						
Refrigerant		R-290						
N° compressors	Nr			1				2
Oil charge	l			3,3				6,6
Refrigerant charge	kg	4,9			4,5			10
No. of circuits	Nr				1			
<b>User side exchanger</b>								
Internal exchanger type	1				PHE			
No. of internal exchangers	Nr				1			
Water content	l	6,2			8,4			10,7
<b>External exchanger</b>								
Type of external exchanger	2				CCHY			
Number of coils	Nr				2			
<b>External Section Fans</b>								
Type of fans	3				AX			
No. of fans	Nr			2				3
Motor type					Brushless DC			
Standard airflow	m <sup>3</sup> /h			38000				53000
Installed unit power	kW			1,5				1,5
<b>Water circuit</b>								
Water fittings					2"			
Maximum water side pressure - without pump on board	bar				10			
Maximum water side pressure - with pump on board	bar				6			
Minimum system water content in heating mode	l	300			500			600
Minimum system water content in cooling mode	l	300			500			600
Total internal water volume	4 l	12,3			14,6			21,3
<b>Power supply</b>								
Standard power supply					400/3~/50			

1. PHE = Plate exchanger
2. CCHY = Coil with aluminium hydrophilic fins
3. AX = Axial fan
4. With ACC option, add the water content of the inertial tank.

## Electrical data

### Power supply voltage 400/3/50+N

SIZE		14.1	16.1	18.1	19.1	20.1	25.2	30.2
<b>F.L.A. - Full load current at max admissible conditions</b>								
F.L.A. - Total	[A]	34,9	34,9	53,3	53,3	53,3	65,8	65,8
<b>F.L.I. - Full load power input at max admissible conditions</b>								
F.L.I. - Total	[kW]	22,0	22,0	34,0	34,0	34,0	41,8	41,8
<b>M.I.C. Maximum inrush current</b>								
M.I.C. - Total	[A]	34,9	34,9	53,3	53,3	53,3	65,8	65,8

## Sound levels - Acoustic configuration with compressor soundproofing (SC)

SIZE	Sound power level (dB) - Octave band (Hz)								Sound pressure level	Sound power level
	63	125	250	500	1000	2000	4000	8000	dB(A)	dB(A)
<b>14.1</b>	65	64	64	67	71	68	62	59	57	75
<b>16.1</b>	65	64	64	67	71	68	62	59	57	75
<b>18.1</b>	67	66	66	69	73	71	65	61	59	77
<b>19.1</b>	67	66	66	69	73	71	65	61	59	77
<b>20.1</b>	67	66	67	70	73	71	65	61	60	78
<b>25.2</b>	67	67	67	70	73	71	66	61	59	78
<b>30.2</b>	68	68	68	71	74	72	67	62	60	79

Sound levels refer to a unit under nominal operating conditions.

The sound pressure level refers to 1 m from the unit outer surface operating in open field.

Sound power levels are determined using the intensimetric method (UNI EN ISO 9614-2).

Data referring to the following conditions in heating mode:

- internal exchanger water temperature = 30/35 °C

- ambient temperature = 7/6 °C

Data referring to the following conditions in cooling mode:

- internal exchanger water temperature = 12/7 °C

- ambient temperature = 35 °C

## Sound levels - Silenced acoustic configuration (LN)

SIZE	Sound power level (dB) - Octave band (Hz)								Sound pressure level	Sound power level
	63	125	250	500	1000	2000	4000	8000	dB(A)	dB(A)
<b>14.1</b>	58	67	63	63	69	60	58	59	55	73
<b>16.1</b>	58	67	63	64	69	60	58	59	55	73
<b>18.1</b>	59	68	64	65	70	62	59	60	56	74
<b>19.1</b>	59	68	64	65	70	62	59	60	56	74
<b>20.1</b>	59	68	65	65	70	62	59	60	56	74
<b>25.2</b>	59	68	65	65	70	62	59	60	56	74
<b>30.2</b>	60	69	66	66	71	63	60	61	56	75

Sound levels refer to a unit under nominal operating conditions.

The sound pressure level refers to 1 m from the unit outer surface operating in open field.

Sound power levels are determined using the intensimetric method (UNI EN ISO 9614-2).

Data referring to the following conditions in heating mode:

- internal exchanger water temperature = 30/35 °C

- ambient temperature = 7/6 °C

Data referring to the following conditions in cooling mode:

- internal exchanger water temperature = 12/7 °C

- ambient temperature = 35 °C

# General technical data

## Sound levels - Super-Silenced acoustic configuration (EN)

SIZE	Sound power level (dB) - Octave band (Hz)								Sound pressure level	Sound power level
	63	125	250	500	1000	2000	4000	8000	dB(A)	dB(A)
<b>14.1</b>	62	54	58	61	63	59	55	57	51	69
<b>16.1</b>	62	54	58	61	63	59	55	57	51	69
<b>18.1</b>	62	54	58	62	63	59	55	57	51	69
<b>19.1</b>	62	54	58	62	63	59	55	57	51	69
<b>20.1</b>	62	54	58	62	63	59	55	58	51	69
<b>25.2</b>	63	55	59	62	63	59	56	58	50	69
<b>30.2</b>	63	55	59	62	64	59	56	58	50	69

Sound levels refer to a unit under nominal operating conditions.

The sound pressure level refers to 1 m from the unit outer surface operating in open field.

Sound power levels are determined using the intensimetric method (UNI EN ISO 9614-2).

Data referring to the following conditions in heating mode:

- internal exchanger water temperature = 30/35 °C

- ambient temperature = 7/6 °C

Data referring to the following conditions in cooling mode:

- internal exchanger water temperature = 12/7 °C

- ambient temperature = 35 °C

## Sound levels ERP - Acoustic configuration SC / LN / EN

SIZE	Sound power level (dB) - Octave band (Hz)								Sound pressure level	Sound power level
	63	125	250	500	1000	2000	4000	8000	dB(A)	dB(A)
<b>14.1</b>	62	55	58	61	63	59	55	56	51	68
<b>16.1</b>	62	55	58	61	63	59	55	56	51	68
<b>18.1</b>	62	54	58	62	63	59	55	57	51	69
<b>19.1</b>	62	54	58	62	63	59	55	57	51	69
<b>20.1</b>	62	54	58	62	63	59	55	57	51	69
<b>25.2</b>	63	55	59	62	63	59	56	58	50	69
<b>30.2</b>	63	55	59	62	63	59	56	58	50	69

Sound levels refer to units operating at Part Load Conditions (PLC) as defined in standard EN12102-1.

Data referring to the following conditions in heating mode:

- internal exchanger water temperature = 7/55 °C

- ambient temperature = 7/6 °C

## Operating limits

### Cooling

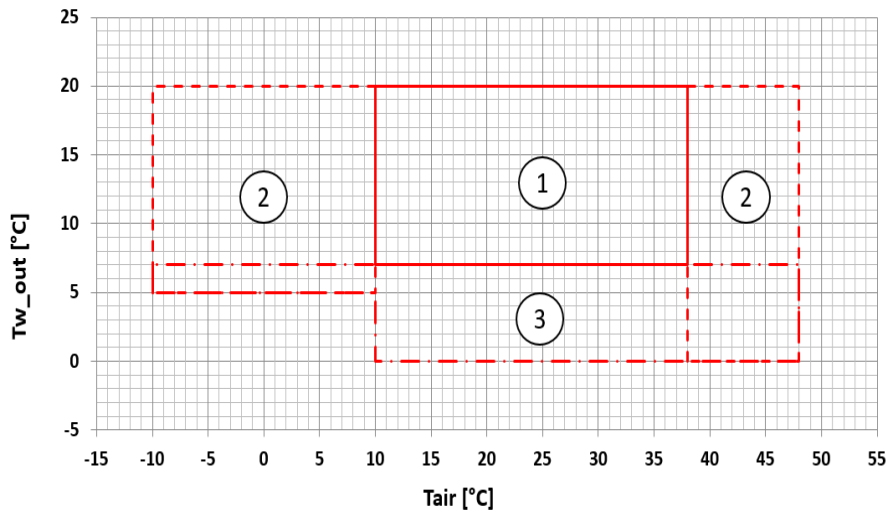

Twu [°C] = Temperature of the outlet water from the unit's exchanger

Tae [°C] = External exchanger inlet air temperature

1. Normal operating range.
2. Unit operating range with automatic staging of the compressor capacity
3. Unit operating range with low water temperature, where it's mandatory the use of ethylene or propylene glycol

### Heating / DHW Production

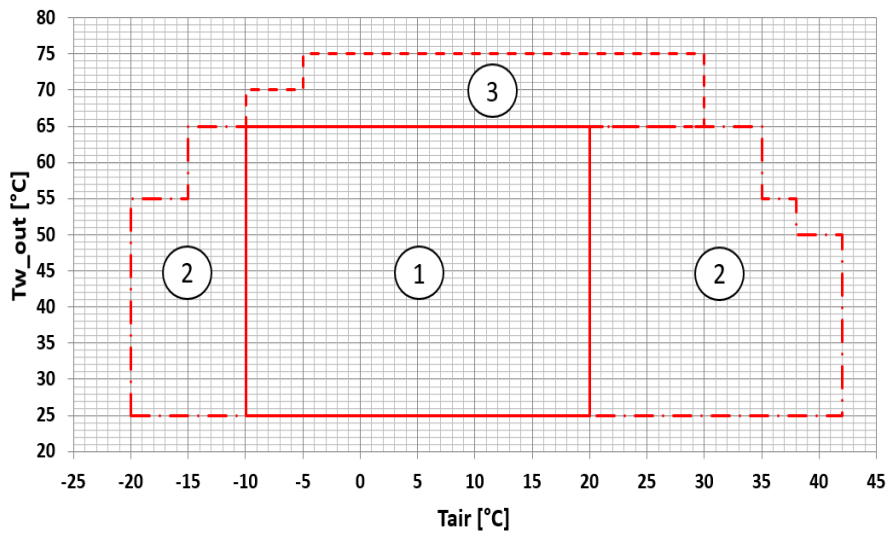

Twu [°C] = Temperature of the outlet water from the unit's exchanger

Tae [°C] = External exchanger inlet air temperature

1. Normal operating range.
2. Unit operating range with automatic staging of the compressor capacity
3. Unit operating range with automatic staging of the compressor capacity, sudden changes in water temperature not permitted

# General technical data

## Correction factors for ethylene glycol use

% ETHYLENE GLYCOL BY WEIGHT		5%	10%	15%	20%	25%	30%	35%	40%	45%	50%
Freezing temperature	°C	-2	-3,9	-6,5	-8,9	-11,8	-15,6	-19,0	-23,4	-27,8	-32,7
Safety temperature	°C	3	1	-1	-4	-6	-10	-14	-19	-23,8	-29,4
Cooling Capacity Factor	Nr	0,997	0,994	0,990	0,986	0,981	0,976	0,970	0,964	0,957	0,950
Compressor power input Factor	Nr	0,999	0,999	0,998	0,997	0,996	0,996	0,995	0,994	0,993	0,993
Internal exchanger pressure drop factor	Nr	1,016	1,035	1,056	1,080	1,106	1,135	1,166	1,200	1,236	1,275

## Correction factors for propylene glycol use

% PROPYLENE GLYCOL BY WEIGHT		5%	10%	15%	20%	25%	30%	35%	40%	45%	50%
Freezing temperature	°C	-2	-3,9	-6,5	-8,9	-11,8	-15,6	-19,0	-23,4	-27,8	-32,7
Safety temperature	°C	3	1	-1	-4	-6	-10	-14	-19	-23,8	-29,4
Cooling Capacity Factor	Nr	0,995	0,990	0,983	0,976	0,968	0,960	0,950	0,939	0,928	0,916
Compressor power input Factor	Nr	0,999	0,997	0,995	0,993	0,991	0,988	0,986	0,983	0,980	0,977
Internal exchanger pressure drop factor	Nr	1,027	1,058	1,093	1,133	1,176	1,224	1,276	1,332	1,393	1,457

## Fouling Correction Factors

### SCAMBIATORE INTERNO (EVAPORATORE)

M2C/W	F1	FK1
0,44x10 (-4)	1	1
0,88x10 (-4)	0,96	0,99
1,76x10 (-4)	0,93	0,98

The cooling performance values given in the tables are based on an external exchanger with clean plates (dirtying factor 1). For different dirtying factor values, multiply the performance by the coefficients in the table.

F1 = Cooling capacity correction factors

FK1 = Compressor power input correction factor

## Exchanger operating range

### SCAMBIATORE INTERNO

		DPR	DPW
Plate exchanger	PED (CE)	4500	1000

DPr = Maximum operating pressure on refrigerant side in kPa

DPw = Maximum operating pressure on water side in kPa

## Overload and control device calibrations

		APERTO	CHIUSO	VALORE
<b>Refrigerant side</b>				
High pressure safety pressure switch	kPa	3100	2400	-
Gas-liquid separator safety valve	kPa	-	-	18
Safety thermostat against compressor drain overheating	°C	115	75	-
<b>Water side</b>				
Antifreeze protection	°C	10	6	-
High pressure safety valve	kPa	-	-	600

## Plate exchanger pressure drops

The water connections are 2" Victaulic.

## Internal exchanger pressure drop curves

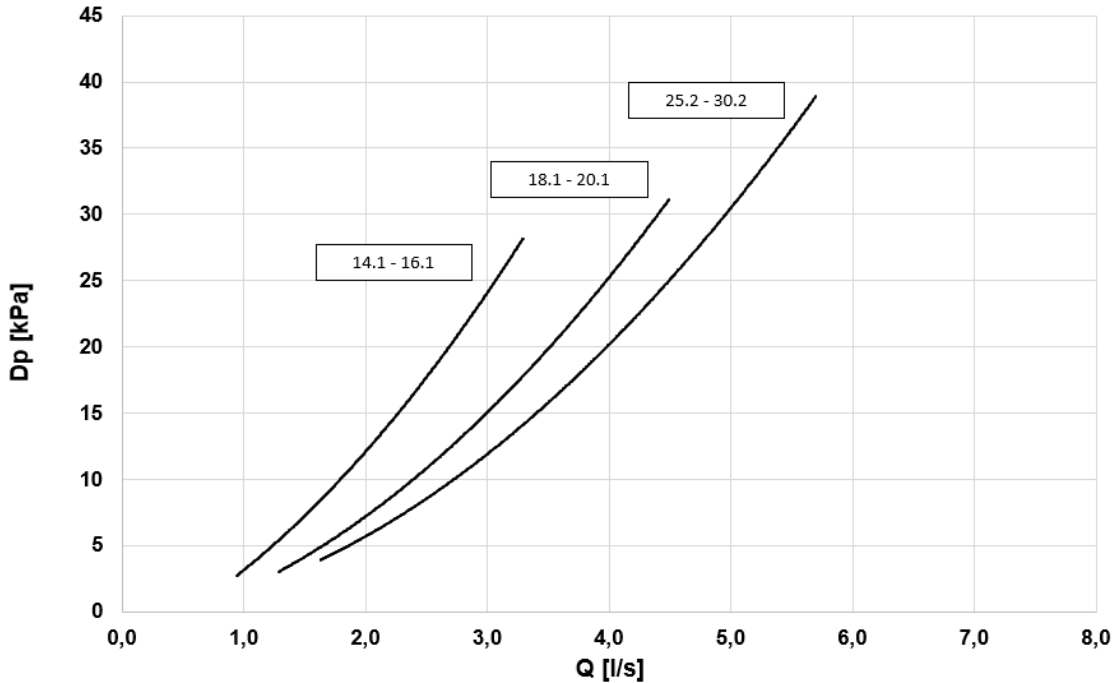

The water side pressure drops are calculated considering an average water temperature of 7°C.

Q = Water flow-rate[l/s]

DP = Pressure drops [kPa]

The water flow rate can be calculated with the following formula:

$$Q [l/s] = kWf / (4,186 \times DT)$$

kWf = Cooling capacity kW]

DT = Difference between water inlet/outlet temperature

⚠ The pressure drops of the internal exchanger must also be added to the pressure drops of the steel mesh filter, which must be placed on the water inlet line. This is a mandatory device for the correct operation of the unit and is supplied as an accessory by Clivet.

## Admissible water flow-rates

Minimum (Qmin) and maximum (Qmax) admissible water flow-rates for correct operation of the unit.

SIZE		14.1	16.1	18.1	19.1	20.1	25.2	30.2
Qmin	l/s	1,1	1,1	1,5	1,5	1,5	1,8	1,8
Qmax	l/s	3,6	3,6	5,0	5,0	5,0	6,3	6,3

# General technical data

## Unit with one inverter pump (HYGU1VI)

Configuration with 1 inverter-controlled centrifugal electric pump with AISI 304 steel body and impeller. The electric pump is equipped with a three-phase electric motor with IP55 protection and complete with thermoformed insulation casing. During installation, it is possible to choose the most suitable head curve for the system by setting the inverter frequency. The pump will always work at fixed flow-rate. The water connections are 2" Victaulic.

Head - Sizes 14.1 - 20.1

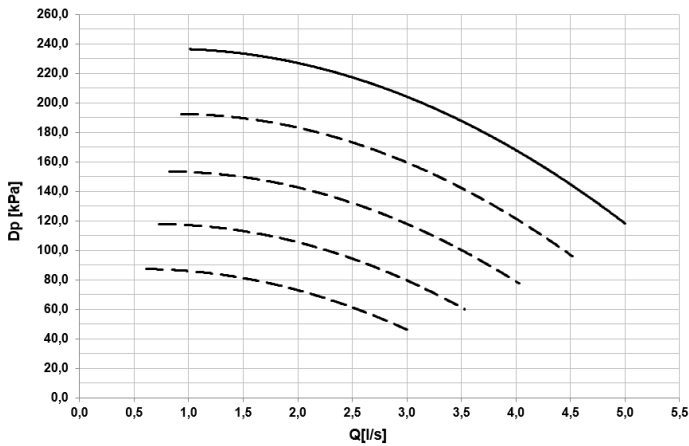

Consumption - Sizes 14.1 - 20.1

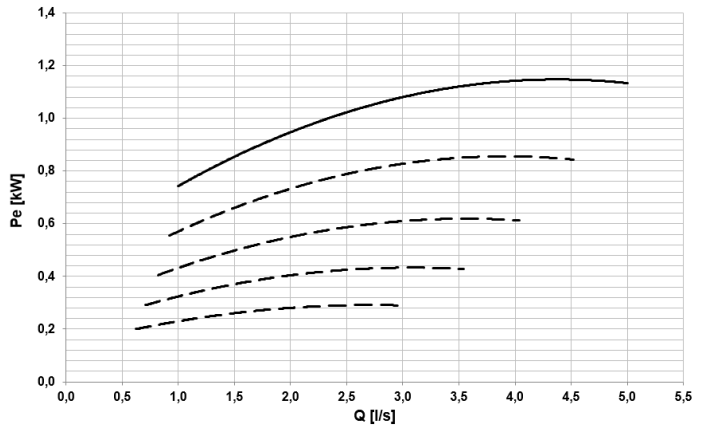

Head - Sizes 25.2-30.2

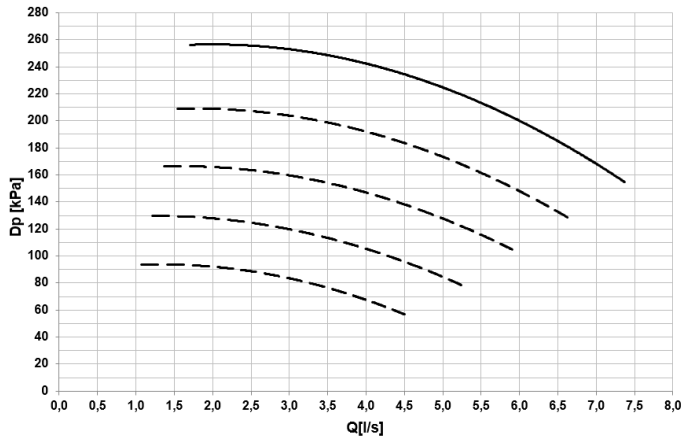

Consumption - Sizes 25.2-30.2

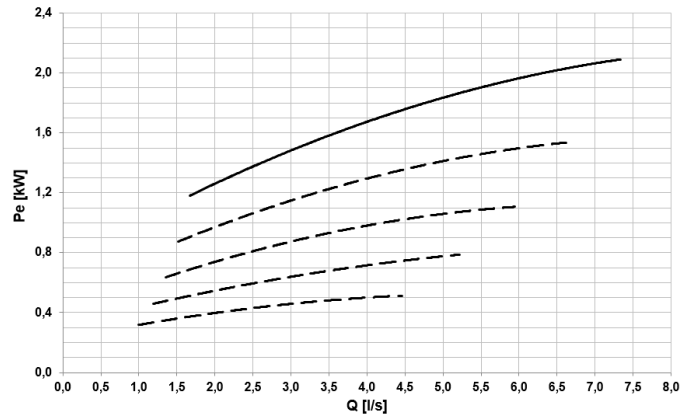

- ⚠ Caution: to obtain the available pressure values, the heads on these diagrams must be decreased by:
- User side exchanger pressure drops
  - IFWX accessory - Steel mesh filter on the water side (where present)

## Admissible water flow rates

SIZE		14.1	16.1	18.1	19.1	20.1	25.2	30.2
F.L.A	A	2,2	2,2	2,2	2,2	2,2	4,6	4,6
F.L.I	kW	1,1	1,1	1,1	1,1	1,1	2,2	2,2

## Cooling - Size 14.1 - SC Version

TAIR DB [°C]	Tw [°C]	Entering external exchanger air temperature (°C)											
		100%		80%		70%		60%		50%		40%	
		Pcool	EER	Pcool	EER	Pcool	EER	Pcool	EER	Pcool	EER	Pcool	EER
<b>-10</b>	5	-	-	-	-	31,5	5,31	27,5	6,45	23,4	6,79	19,3	7,25
	7	-	-	-	-	34,2	5,72	29,1	6,68	25,6	7,41	21,1	7,95
	10	-	-	-	-	37,9	6,28	33,1	7,67	28,2	8,15	23,2	8,73
	12	-	-	-	-	40,2	6,61	35,1	8,09	29,9	8,63	24,7	9,31
	15	-	-	-	-	43,8	7,10	38,3	8,75	32,7	9,40	27,0	10,19
	18	-	-	-	-	48,0	7,67	42,2	9,53	36,4	11,12	30,2	12,7
	20	-	-	-	-	51,8	8,46	45,5	10,7	38,9	11,91	31,1	13,7
<b>15</b>	5	40,9	4,37	36,9	4,51	29,7	4,61	25,9	5,54	22,1	5,85	18,2	6,27
	7	43,9	4,63	39,9	4,81	32,2	4,96	27,4	5,74	24,1	6,39	19,9	6,87
	10	49,1	5,04	44,5	5,25	35,7	5,45	31,2	6,59	26,6	7,02	21,9	7,55
	12	52,0	5,25	47,1	5,49	37,9	5,73	33,2	6,95	28,3	7,43	23,3	8,05
	15	56,5	5,55	51,3	5,84	41,3	6,16	36,2	7,52	30,8	8,09	25,5	8,81
	18	61,1	5,83	55,7	6,19	45,3	6,65	39,8	8,18	34,3	9,59	28,5	10,98
	20	64,4	6,05	60,4	6,53	48,9	7,33	42,9	9,20	36,7	10,27	29,3	11,92
<b>20</b>	5	38,9	3,87	35,3	4,02	28,5	4,15	24,9	4,98	21,2	5,29	17,5	5,68
	7	42,0	4,12	38,2	4,30	31,0	4,50	26,3	5,29	23,2	5,79	19,2	6,26
	10	46,9	4,49	42,5	4,71	34,3	4,94	30,0	5,96	25,6	6,38	21,1	6,92
	12	49,6	4,69	45,1	4,93	36,4	5,21	31,9	6,31	27,2	6,78	22,4	7,39
	15	54,0	4,98	49,1	5,27	39,7	5,62	34,8	6,84	29,7	7,40	24,5	8,10
	18	58,6	5,27	53,6	5,63	43,6	6,10	38,4	7,49	33,0	8,22	27,3	9,12
	20	61,6	5,47	58,0	5,95	46,9	6,48	41,2	7,97	35,2	8,76	28,3	10,22
<b>25</b>	5	37,0	3,42	33,6	3,57	27,2	3,73	23,9	4,45	20,4	4,73	16,8	5,09
	7	40,0	3,65	36,5	3,83	29,7	4,05	25,2	4,72	22,3	5,21	18,4	5,61
	10	44,6	3,99	40,6	4,21	32,8	4,45	28,8	5,35	24,5	5,75	20,2	6,23
	12	47,3	4,17	43,0	4,42	34,8	4,71	30,6	5,68	26,1	6,12	21,5	6,67
	15	51,4	4,45	46,9	4,74	38,0	5,10	33,4	6,18	28,5	6,71	23,5	7,34
	18	56,1	4,75	51,4	5,10	42,0	5,56	37,0	6,81	31,7	7,48	26,2	8,29
	20	58,9	4,93	55,5	5,41	45,0	5,92	39,6	7,25	33,9	7,99	27,3	8,68
<b>30</b>	5	35,0	3,01	31,9	3,16	26,0	3,34	22,8	3,95	19,5	4,20	16,0	4,49
	7	38,0	3,23	34,8	3,41	28,4	3,63	24,1	4,19	21,3	4,64	17,5	4,96
	10	42,3	3,53	38,6	3,74	31,3	3,99	27,5	4,77	23,5	5,12	19,3	5,53
	12	44,9	3,71	41,0	3,95	33,3	4,23	29,2	5,07	25,0	5,48	20,5	5,93
	15	48,9	3,97	44,7	4,25	36,3	4,59	32,0	5,54	27,3	6,02	22,5	6,55
	18	53,6	4,27	49,2	4,60	40,2	5,05	35,5	6,14	30,5	6,74	25,1	7,44
	20	56,2	4,44	53,0	4,89	43,1	5,37	38,0	6,54	32,5	7,20	26,2	7,80

# Performances

## Cooling - Size 14.1 - SC Version

TAIR DB [°C]	To (°C)	Entering external exchanger air temperature (°C)											
		100%		80%		70%		60%		50%		40%	
		Pcool	EER	Pcool	EER	Pcool	EER	Pcool	EER	Pcool	EER	Pcool	EER
35	5	33,0	2,65	30,2	2,79	24,7	2,96	21,7	3,49	18,5	3,70	15,2	3,93
	7	34,9	2,85	33,0	3,03	27,0	3,24	22,9	3,70	20,3	4,09	16,7	4,36
	10	39,9	3,12	36,6	3,33	29,8	3,56	26,2	4,23	22,4	4,53	18,4	4,86
	12	42,4	3,29	38,9	3,51	31,7	3,79	27,9	4,51	23,8	4,85	19,6	5,22
	15	42,5	3,80	42,5	3,80	34,7	4,13	30,5	4,94	26,1	5,34	21,5	5,78
	18	42,6	4,31	41,4	4,18	38,5	4,56	34,0	5,50	29,2	6,02	24,0	6,58
	20	41,2	4,85	41,2	4,85	41,2	4,85	36,3	5,87	31,1	6,43	25,0	6,91
40	5	31,0	2,32	28,5	2,46	23,3	2,63	20,5	3,06	17,6	3,24	14,4	3,42
	7	33,9	2,52	31,2	2,68	25,6	2,88	21,7	3,24	19,3	3,58	15,8	3,78
	10	37,6	2,75	34,5	2,94	28,3	3,17	24,9	3,73	21,3	3,98	17,5	4,23
	12	40,0	2,91	36,7	3,12	30,1	3,37	26,5	3,99	22,7	4,26	18,6	4,55
	15	43,7	3,14	40,2	3,38	33,0	3,69	29,1	4,38	24,9	4,72	20,4	5,05
	18	36,7	4,09	36,7	4,09	36,7	4,09	32,5	4,91	27,9	5,33	22,9	5,76
	20	34,6	5,23	34,6	5,23	34,6	5,23	34,6	5,23	29,7	5,69	23,8	6,05
44	5	-	-	27,1	2,22	22,3	2,37	19,6	2,75	16,8	2,90	13,8	3,03
	7	-	-	29,7	2,42	24,6	2,67	21,6	3,03	18,4	3,21	15,1	3,36
	10	-	-	32,9	2,66	27,0	2,88	23,8	3,36	20,5	3,71	16,7	3,77
	12	-	-	35,0	2,82	28,8	3,06	25,4	3,60	21,7	3,83	17,8	4,05
	15	-	-	38,4	3,08	31,6	3,36	27,9	3,96	23,9	4,25	19,6	4,51
	18	-	-	35,3	3,75	35,3	3,75	31,2	4,45	26,9	4,95	21,9	5,14
	20	-	-	33,3	4,75	33,3	4,75	33,3	4,75	28,5	5,15	23,4	5,52
48	5	-	-	25,6	1,99	21,2	2,14	18,7	2,47	16,0	2,59	13,1	2,68
	7	-	-	27,1	2,10	23,3	2,35	20,6	2,72	17,6	2,86	14,4	2,97
	10	-	-	31,2	2,40	25,8	2,60	22,7	3,02	19,5	3,20	15,9	3,33
	12	-	-	33,3	2,55	27,5	2,77	24,3	3,23	20,8	3,43	17,0	3,59
	15	-	-	36,6	2,79	30,2	3,05	26,7	3,57	22,8	3,81	18,7	4,00
	18	-	-	29,0	3,90	29,0	3,90	29,0	3,90	25,6	4,32	21,0	4,56
	20	-	-	27,3	4,63	27,3	4,63	27,3	4,63	27,3	4,63	22,4	4,92

To = Internal exchanger outlet water temperature (°C)

Tae [°C] = External exchanger inlet air temperature

Performance calculated with the inlet/outlet water temperature difference = 5°C\*

\*Always check the actual temperature difference on the configurator, as it is linked to the minimum or maximum flow-rate limits of the exchanger

## Cooling - Size 16.1 - SC Version

TAIR DB [°C]	Tw [°C]	Entering external exchanger air temperature (°C)											
		100%		80%		70%		60%		50%		40%	
		Pcool	EER	Pcool	EER	Pcool	EER	Pcool	EER	Pcool	EER	Pcool	EER
<b>-10</b>	5	-	-	-	-	33,5	5,38	28,8	6,34	24,8	6,66	20,2	7,18
	7	-	-	-	-	36,3	5,79	31,0	6,82	27,1	7,25	22,2	7,87
	10	-	-	-	-	40,4	6,36	34,7	7,52	29,8	7,98	24,4	8,65
	12	-	-	-	-	42,9	6,69	36,8	7,94	31,7	8,46	25,9	9,22
	15	-	-	-	-	46,7	7,17	40,2	8,56	34,6	9,16	28,3	10,1
	18	-	-	-	-	51,1	7,71	44,2	9,27	37,6	9,99	30,7	11,0
	20	-	-	-	-	53,4	8,04	46,3	9,66	39,6	10,5	32,3	11,53
<b>15</b>	5	42,7	4,30	42,7	4,30	31,6	4,67	27,2	5,44	23,4	5,73	19,1	6,21
	7	45,9	4,54	45,9	4,54	34,3	5,02	29,2	5,85	25,5	6,24	20,9	6,81
	10	51,3	4,93	51,3	4,93	38,1	5,51	32,7	6,46	28,2	6,87	23,0	7,48
	12	54,3	5,12	54,3	5,12	40,5	5,80	34,8	6,81	29,9	7,27	24,4	7,98
	15	59,0	5,40	59,0	5,40	44,1	6,22	37,9	7,34	32,6	7,88	26,7	8,73
	18	63,7	5,65	63,7	5,65	48,2	6,68	41,7	7,95	35,5	8,59	29,0	9,48
	20	67,4	5,90	67,4	5,90	50,4	6,96	43,7	8,29	37,4	9,02	30,5	9,98
<b>20</b>	5	40,7	3,79	40,7	3,79	30,3	4,20	26,1	4,89	22,5	5,18	18,4	5,62
	7	43,8	4,02	43,8	4,02	32,9	4,54	28,0	5,25	24,6	5,66	20,1	6,20
	10	48,9	4,38	48,9	4,38	36,6	4,99	31,4	5,83	27,1	6,24	22,1	6,86
	12	51,8	4,56	51,8	4,56	38,8	5,26	33,4	6,16	28,8	6,61	23,5	7,32
	15	56,3	4,83	56,3	4,83	42,3	5,67	36,4	6,67	31,4	7,22	25,7	8,02
	18	61,0	5,09	61,0	5,09	46,5	6,12	40,2	7,28	34,8	7,97	28,6	9,03
	20	64,3	5,31	64,3	5,31	50,1	6,50	43,1	7,73	37,2	8,48	29,3	9,32
<b>25</b>	5	38,6	3,34	38,6	3,34	29,0	3,76	25,0	4,36	21,5	4,63	17,6	5,04
	7	41,7	3,55	41,7	3,55	31,6	4,08	26,8	4,67	23,6	5,08	19,3	5,56
	10	46,5	3,88	46,5	3,88	35,0	4,49	30,1	5,23	26,0	5,61	21,2	6,17
	12	49,3	4,05	49,3	4,05	37,1	4,74	32,0	5,54	27,6	5,96	22,5	6,60
	15	53,6	4,31	53,6	4,31	40,5	5,13	34,9	6,02	30,2	6,53	24,7	7,27
	18	58,3	4,58	58,3	4,58	44,7	5,58	38,7	6,61	33,5	7,24	27,5	8,22
	20	61,2	4,76	61,2	4,76	48,1	5,94	41,4	7,04	35,8	7,73	29,3	8,80
<b>30</b>	5	36,5	2,93	36,5	2,93	27,6	3,36	23,9	3,87	20,6	4,11	16,8	4,45
	7	39,5	3,14	39,5	3,14	30,2	3,66	25,5	4,15	22,6	4,53	18,4	4,92
	10	44,0	3,43	44,0	3,43	33,4	4,02	28,8	4,67	24,8	5,01	20,3	5,48
	12	46,7	3,59	46,7	3,59	35,5	4,26	30,6	4,95	26,4	5,34	21,6	5,88
	15	50,9	3,84	50,9	3,84	38,7	4,62	33,4	5,39	28,9	5,85	23,6	6,49
	18	55,6	4,11	55,6	4,11	42,8	5,06	37,1	5,96	32,2	6,53	26,4	7,37
	20	58,1	4,27	58,1	4,27	46,0	5,39	39,7	6,34	34,3	6,97	28,1	7,91

# Performances

## Cooling - Size 16.1 - SC Version

TAIR DB [°C]	To (°C)	Entering external exchanger air temperature (°C)											
		100%		80%		70%		60%		50%		40%	
		Pcool	EER	Pcool	EER	Pcool	EER	Pcool	EER	Pcool	EER	Pcool	EER
<b>35</b>	5	34,4	2,57	34,4	2,57	26,2	2,98	22,7	3,42	19,6	3,63	16,0	3,90
	7	38,5	2,82	37,4	2,76	28,7	3,26	24,2	3,66	21,5	4,00	17,5	4,31
	10	41,5	3,02	41,5	3,02	31,7	3,59	27,4	4,14	23,7	4,43	19,3	4,82
	12	44,1	3,18	44,1	3,18	33,8	3,81	29,2	4,40	25,2	4,73	20,6	5,17
	15	48,1	3,41	48,1	3,41	36,9	4,14	31,9	4,81	27,6	5,21	22,5	5,73
	18	46,8	4,01	45,5	3,90	41,0	4,57	35,5	5,34	30,8	5,84	25,2	6,52
	20	43,9	4,86	43,9	4,86	43,9	4,86	38,0	5,69	32,9	6,24	26,8	6,99
<b>40</b>	5	32,2	2,25	32,2	2,25	24,8	2,64	21,5	3,00	18,6	3,18	15,1	3,38
	7	35,2	2,43	35,2	2,43	27,3	2,89	22,9	3,21	20,4	3,51	16,6	3,74
	10	39,0	2,66	39,0	2,66	30,1	3,19	26,0	3,65	22,5	3,90	18,3	4,19
	12	41,5	2,80	41,5	2,80	32,0	3,39	27,7	3,89	24,0	4,17	19,5	4,50
	15	45,3	3,02	45,3	3,02	35,1	3,70	30,4	4,27	26,3	4,61	21,4	5,00
	18	39,1	4,11	39,1	4,11	39,1	4,11	33,9	4,77	29,4	5,18	24,0	5,71
	20	36,2	5,08	36,2	5,08	36,2	5,08	36,2	5,08	31,4	5,54	25,6	6,12
<b>44</b>	5	-	-	30,5	2,02	23,7	2,39	20,5	2,70	17,8	2,86	14,5	3,00
	7	-	-	33,4	2,19	26,0	2,62	22,6	2,98	19,5	3,15	15,8	3,33
	10	-	-	37,0	2,40	28,7	2,89	24,9	3,29	22,1	3,60	17,5	3,73
	12	-	-	39,3	2,53	30,6	3,08	26,6	3,51	23,0	3,75	18,7	4,01
	15	-	-	43,1	2,74	33,6	3,37	29,1	3,86	25,2	4,15	20,5	4,46
	18	-	-	37,5	3,75	37,5	3,75	32,6	4,33	27,6	4,57	23,0	5,09
	20	-	-	34,8	4,62	34,8	4,62	34,8	4,62	30,2	5,02	24,5	5,47
<b>48</b>	5	-	-	28,7	1,80	22,5	2,15	19,6	2,42	16,9	2,55	13,8	2,65
	7	-	-	31,5	1,96	23,7	2,27	21,5	2,67	18,6	2,82	15,1	2,95
	10	-	-	34,9	2,15	27,4	2,61	23,8	2,96	20,6	3,14	16,7	3,30
	12	-	-	37,2	2,28	29,2	2,79	25,4	3,17	22,0	3,37	17,8	3,56
	15	-	-	40,8	2,47	32,1	3,06	27,9	3,49	24,1	3,73	19,6	3,96
	18	-	-	31,3	3,93	31,3	3,93	31,3	3,93	27,1	4,22	22,0	4,52
	20	-	-	28,9	4,52	28,9	4,52	28,9	4,52	28,9	4,52	23,5	4,87

To = Internal exchanger outlet water temperature (°C)

Tae [°C] = External exchanger inlet air temperature

Performance calculated with the inlet/outlet water temperature difference = 5°C\*

\*Always check the actual temperature difference on the configurator, as it is linked to the minimum or maximum flow-rate limits of the exchanger

## Cooling - Size 18.1 - SC Version

TAIR DB [°C]	Tw [°C]	Entering external exchanger air temperature (°C)											
		100%		80%		70%		60%		50%		40%	
		Pcool	EER	Pcool	EER	Pcool	EER	Pcool	EER	Pcool	EER	Pcool	EER
<b>-10</b>	5	-	-	-	-	46,9	5,12	41,0	5,51	35,6	5,92	30,6	6,35
	7	-	-	-	-	51,1	5,51	44,4	5,83	38,6	6,29	33,3	6,77
	10	-	-	-	-	56,7	6,08	48,6	6,21	42,2	6,72	36,4	7,26
	12	-	-	-	-	60,5	6,38	51,6	6,53	44,5	7,00	38,4	7,60
	15	-	-	-	-	64,9	6,63	56,5	7,06	48,2	7,40	41,7	8,09
	18	-	-	-	-	70,4	6,94	62,5	7,70	53,2	8,02	45,9	8,71
	20	-	-	-	-	75,5	7,21	66,3	7,95	57,2	8,54	48,7	9,12
<b>15</b>	5	61,1	3,91	52,1	4,22	44,2	4,37	38,7	4,71	33,6	5,07	28,9	5,44
	7	65,1	4,06	56,1	4,44	48,2	4,71	41,9	4,98	36,4	5,38	31,4	5,81
	10	72,2	4,30	61,9	4,72	53,5	5,19	45,8	5,30	39,8	5,75	34,3	6,23
	12	76,0	4,42	65,3	4,88	57,1	5,44	48,7	5,58	42,0	5,99	36,3	6,51
	15	81,9	4,57	70,4	5,10	61,2	5,65	53,3	6,04	45,5	6,33	39,3	6,94
	18	87,9	4,72	76,1	5,32	66,5	5,92	59,0	6,57	50,2	6,86	43,3	7,47
	20	94,8	4,86	82,0	5,52	71,3	6,15	62,6	6,79	54,0	7,30	45,9	7,81
<b>20</b>	5	58,7	3,52	50,2	3,82	42,7	3,96	37,4	4,29	32,5	4,60	28,0	4,94
	7	62,9	3,68	54,0	4,01	46,2	4,19	40,6	4,55	35,3	4,91	30,4	5,29
	10	69,4	3,89	59,6	4,30	50,5	4,43	44,3	4,84	38,5	5,25	33,2	5,68
	12	73,1	4,01	62,9	4,45	53,2	4,58	46,8	5,03	40,7	5,48	35,1	5,95
	15	78,8	4,17	68,0	4,67	57,5	4,86	50,6	5,30	44,1	5,80	38,1	6,35
	18	84,7	4,32	73,7	4,90	64,5	5,38	55,4	5,60	48,5	6,22	42,0	6,86
	20	91,3	4,48	79,2	5,09	69,0	5,65	59,0	5,88	51,5	6,48	44,5	7,18
<b>25</b>	5	56,9	3,19	46,3	3,18	41,1	3,58	36,1	3,87	31,3	4,15	27,0	4,43
	7	60,4	3,31	50,8	3,46	44,6	3,80	39,2	4,11	34,1	4,44	29,3	4,76
	10	66,5	3,52	56,7	3,82	48,7	4,03	42,8	4,39	37,2	4,75	32,0	5,12
	12	70,0	3,63	60,5	4,04	51,3	4,17	45,2	4,57	39,3	4,96	33,9	5,37
	15	75,6	3,79	65,4	4,25	55,5	4,37	48,9	4,83	42,6	5,27	36,8	5,74
	18	81,6	3,95	71,1	4,48	60,5	4,60	53,7	5,13	46,9	5,67	40,6	6,22
	20	87,7	4,10	76,3	4,67	64,3	4,76	57,0	5,32	49,8	5,91	43,0	6,51
<b>30</b>	5	51,8	2,61	45,2	2,93	39,5	3,22	34,7	3,47	30,1	3,71	25,9	3,93
	7	56,5	2,81	48,8	3,09	42,9	3,42	37,7	3,70	32,8	3,97	28,2	4,23
	10	63,3	3,10	53,4	3,28	46,8	3,64	41,2	3,95	35,8	4,26	30,8	4,56
	12	67,5	3,28	56,3	3,40	49,4	3,78	43,5	4,13	37,8	4,46	32,6	4,79
	15	72,2	3,43	61,9	3,70	53,4	3,97	47,1	4,37	41,0	4,75	35,4	5,13
	18	78,3	3,60	68,5	4,04	58,4	4,20	51,8	4,66	45,3	5,12	39,2	5,58
	20	83,9	3,74	73,3	4,26	62,0	4,35	55,0	4,84	48,0	5,33	41,4	5,84

# Performances

## Cooling - Size 18.1 - SC Version

TAIR DB [°C]	To (°C)	Entering external exchanger air temperature (°C)											
		100%		80%		70%		60%		50%		40%	
		Pcool	EER	Pcool	EER	Pcool	EER	Pcool	EER	Pcool	EER	Pcool	EER
<b>35</b>	5	49,3	2,34	43,2	2,63	37,8	2,88	33,2	3,09	28,9	3,29	24,8	3,46
	7	50,0	2,59	46,8	2,93	41,1	3,07	36,2	3,31	31,4	3,53	27,0	3,73
	10	58,0	2,73	51,1	3,12	44,8	3,27	39,5	3,54	34,3	3,80	29,5	4,03
	12	61,2	2,69	53,9	3,08	47,3	3,40	41,7	3,70	36,3	3,98	31,2	4,23
	15	58,2	3,24	58,2	3,24	51,2	3,59	45,3	3,93	39,4	4,24	33,9	4,54
	18	55,7	3,68	56,2	3,60	56,2	3,81	49,9	4,21	43,6	4,58	36,7	4,85
	20	59,6	3,95	59,6	3,95	59,6	3,95	52,9	4,37	46,2	4,79	39,8	5,18
<b>40</b>	5	46,7	2,09	41,1	2,35	36,0	2,56	31,7	2,74	27,5	2,90	23,6	3,02
	7	50,5	2,21	44,6	2,50	39,2	2,73	34,5	2,94	30,0	3,12	25,7	3,26
	10	55,0	2,34	48,7	2,67	42,8	2,92	37,7	3,15	32,8	3,36	28,1	3,53
	12	57,9	2,42	51,4	2,77	45,2	3,04	39,9	3,29	34,7	3,52	29,8	3,71
	15	62,5	2,54	55,6	2,93	49,0	3,22	43,3	3,51	37,7	3,77	32,4	3,99
	18	53,9	3,44	53,9	3,44	53,9	3,44	47,8	3,78	41,8	4,08	36,0	4,35
	20	50,7	3,93	50,7	3,93	50,7	3,93	50,7	3,93	44,2	4,27	38,1	4,56
<b>44</b>	5	-	-	39,4	2,15	34,6	2,33	30,5	2,48	26,5	2,61	22,7	2,70
	7	-	-	42,8	2,29	36,5	2,44	33,2	2,67	28,8	2,81	24,7	2,92
	10	-	-	46,7	2,44	41,1	2,66	36,3	2,86	31,5	3,03	27,0	3,16
	12	-	-	49,4	2,54	43,4	2,78	38,4	2,99	33,4	3,18	28,6	3,33
	15	-	-	53,5	2,69	47,1	2,95	41,7	3,20	36,3	3,41	31,2	3,58
	18	-	-	51,9	3,16	51,9	3,16	46,2	3,45	40,3	3,70	34,6	3,91
	20	-	-	48,9	3,59	48,9	3,59	48,9	3,59	41,9	3,82	36,0	4,05
<b>48</b>	5	-	-	37,7	1,95	33,1	2,11	29,2	2,24	25,4	2,34	21,7	2,40
	7	-	-	41,0	2,08	36,0	2,26	31,8	2,41	27,6	2,52	23,6	2,60
	10	-	-	44,7	2,23	39,4	2,42	34,8	2,59	30,2	2,73	25,9	2,82
	12	-	-	47,3	2,33	41,7	2,53	36,8	2,71	32,0	2,86	27,4	2,97
	15	-	-	51,3	2,47	45,2	2,69	40,1	2,90	34,9	3,07	29,9	3,20
	18	-	-	43,3	3,09	43,3	3,09	43,3	3,09	38,7	3,34	33,2	3,49
	20	-	-	41,0	3,49	41,0	3,49	41,0	3,49	41,0	3,49	35,2	3,67

To = Internal exchanger outlet water temperature (°C)

Tae [°C] = External exchanger inlet air temperature

Performance calculated with the inlet/outlet water temperature difference = 5°C\*

\*Always check the actual temperature difference on the configurator, as it is linked to the minimum or maximum flow-rate limits of the exchanger

## Cooling - Size 19.1 - SC Version

TAIR DB [°C]	Tw [°C]	Entering external exchanger air temperature (°C)											
		100%		80%		70%		60%		50%		40%	
		Pcool	EER	Pcool	EER	Pcool	EER	Pcool	EER	Pcool	EER	Pcool	EER
<b>-10</b>	5	-	-	-	-	49,1	5,07	43,0	5,38	36,9	5,81	31,6	6,29
	7	-	-	-	-	53,6	5,48	46,5	5,66	40,1	6,17	34,3	6,71
	10	-	-	-	-	59,7	6,01	51,3	6,14	43,8	6,58	37,5	7,19
	12	-	-	-	-	62,4	6,16	54,6	6,47	46,2	6,84	39,6	7,52
	15	-	-	-	-	67,5	6,45	59,7	7,00	50,1	7,23	42,9	8,01
	18	-	-	-	-	73,2	6,74	65,0	7,39	55,6	7,93	47,3	8,63
	20	-	-	-	-	78,5	6,98	69,5	7,69	59,7	8,44	50,1	9,03
<b>15</b>	5	63,8	3,63	58,2	3,81	46,3	4,33	40,6	4,59	34,9	4,97	29,8	5,39
	7	68,0	3,77	62,4	3,98	50,5	4,67	43,8	4,84	37,8	5,28	32,4	5,75
	10	75,4	3,99	68,9	4,23	56,3	5,13	48,4	5,24	41,3	5,63	35,3	6,17
	12	79,3	4,09	72,6	4,36	58,9	5,26	51,5	5,53	43,6	5,85	37,4	6,45
	15	85,4	4,24	78,2	4,54	63,7	5,50	56,3	5,97	47,3	6,18	40,5	6,87
	18	91,6	4,37	84,1	4,70	69,0	5,75	61,3	6,31	52,4	6,78	44,6	7,39
	20	96,2	4,48	90,7	4,86	74,0	5,96	65,6	6,56	56,4	7,22	47,3	7,74
<b>20</b>	5	61,3	3,27	56,0	3,45	44,4	3,87	39,2	4,18	33,7	4,52	28,8	4,89
	7	65,4	3,41	60,1	3,62	48,0	4,07	42,5	4,42	36,6	4,82	31,3	5,24
	10	72,4	3,62	66,3	3,85	52,4	4,30	46,5	4,71	40,0	5,15	34,2	5,63
	12	76,2	3,72	69,8	3,97	55,7	4,52	49,0	4,87	42,3	5,35	36,2	5,89
	15	82,0	3,87	75,4	4,15	60,3	4,82	53,0	5,12	45,8	5,67	39,2	6,29
	18	88,1	4,00	81,2	4,32	66,6	5,23	58,4	5,52	50,3	6,05	43,2	6,80
	20	92,4	4,11	87,5	4,49	71,5	5,47	63,0	5,88	53,4	6,29	45,9	7,11
<b>25</b>	5	58,6	2,94	52,7	3,01	42,8	3,50	37,8	3,77	32,5	4,08	27,8	4,38
	7	62,9	3,08	58,5	3,31	46,3	3,69	41,0	4,00	35,4	4,35	30,2	4,71
	10	69,2	3,27	63,6	3,49	50,5	3,91	44,8	4,27	38,6	4,66	33,0	5,07
	12	72,9	3,37	67,0	3,61	53,3	4,04	47,3	4,43	40,8	4,86	34,9	5,32
	15	78,6	3,52	72,4	3,79	57,5	4,23	51,2	4,67	44,2	5,15	37,9	5,68
	18	84,6	3,66	78,3	3,96	62,7	4,44	56,0	4,94	48,7	5,52	41,8	6,16
	20	88,7	3,76	84,1	4,12	66,1	4,58	59,5	5,12	51,6	5,74	44,3	6,45
<b>30</b>	5	54,3	2,47	49,7	2,60	41,1	3,15	36,3	3,39	31,3	3,65	26,7	3,89
	7	59,5	2,68	53,6	2,74	44,5	3,33	39,5	3,60	34,0	3,90	29,0	4,19
	10	66,8	2,96	59,8	3,02	48,5	3,53	43,1	3,85	37,2	4,18	31,7	4,52
	12	69,5	3,04	63,8	3,19	51,2	3,66	45,5	4,00	39,3	4,37	33,6	4,75
	15	75,0	3,19	70,0	3,46	55,3	3,85	49,3	4,23	42,6	4,65	36,5	5,08
	18	81,1	3,33	75,2	3,62	60,5	4,06	54,1	4,50	47,0	5,00	40,3	5,52
	20	85,5	3,49	80,6	3,77	64,2	4,20	57,4	4,67	49,8	5,20	42,7	5,78

# Performances

## Cooling - Size 19.1 - SC Version

TAIR DB [°C]	To (°C)	Entering external exchanger air temperature (°C)											
		100%		80%		70%		60%		50%		40%	
		Pcool	EER	Pcool	EER	Pcool	EER	Pcool	EER	Pcool	EER	Pcool	EER
<b>35</b>	5	51,0	2,17	47,4	2,35	39,2	2,81	34,8	3,02	30,0	3,24	25,5	3,43
	7	54,1	2,47	51,2	2,60	42,6	2,99	37,8	3,23	32,6	3,47	27,8	3,69
	10	60,2	2,54	55,9	2,75	46,5	3,18	41,3	3,45	35,6	3,73	30,4	3,99
	12	64,3	2,57	58,8	2,71	49,1	3,30	43,7	3,60	37,7	3,90	32,2	4,19
	15	62,4	2,81	62,4	2,81	53,0	3,48	47,3	3,81	40,9	4,16	35,0	4,50
	18	59,8	3,65	58,0	3,59	58,1	3,69	52,1	4,07	45,2	4,49	37,8	4,80
	20	61,6	3,82	61,6	3,82	61,6	3,82	55,2	4,23	47,9	4,68	41,0	5,13
<b>40</b>	5	48,3	1,94	45,0	2,10	37,4	2,50	33,2	2,69	28,6	2,86	24,3	2,99
	7	52,1	2,05	48,7	2,22	40,6	2,67	36,2	2,87	31,2	3,08	26,5	3,23
	10	56,7	2,16	53,1	2,36	44,3	2,85	39,4	3,07	34,0	3,31	29,0	3,50
	12	59,7	2,24	56,0	2,45	46,8	2,96	41,8	3,22	36,0	3,47	30,7	3,68
	15	64,2	2,34	60,4	2,58	50,7	3,13	45,3	3,41	39,2	3,70	33,4	3,96
	18	55,7	3,33	55,7	3,33	55,7	3,33	49,9	3,66	43,4	4,01	37,0	4,31
	20	52,9	3,81	52,9	3,81	52,9	3,81	52,9	3,81	45,9	4,18	39,2	4,52
<b>44</b>	5	-	-	43,0	1,92	35,9	2,28	31,9	2,43	27,5	2,58	23,4	2,68
	7	-	-	46,6	2,04	39,0	2,43	34,7	2,61	29,9	2,77	25,4	2,89
	10	-	-	50,8	2,17	42,6	2,59	37,9	2,80	32,7	2,99	27,8	3,13
	12	-	-	53,6	2,25	45,0	2,70	40,2	2,93	34,7	3,14	29,5	3,29
	15	-	-	57,9	2,37	48,7	2,86	43,6	3,12	37,7	3,35	32,1	3,55
	18	-	-	53,7	3,06	53,7	3,06	48,2	3,35	40,7	3,57	35,6	3,87
	20	-	-	51,0	3,49	51,0	3,49	51,0	3,49	44,3	3,80	37,1	4,01
<b>48</b>	5	-	-	41,0	1,75	34,3	2,06	30,6	2,20	26,4	2,32	22,3	2,38
	7	-	-	44,5	1,86	37,4	2,21	32,2	2,30	28,7	2,50	24,3	2,57
	10	-	-	48,5	1,98	40,8	2,36	36,4	2,53	31,4	2,70	26,6	2,79
	12	-	-	51,2	2,06	43,1	2,46	38,5	2,65	33,3	2,83	28,3	2,94
	15	-	-	55,4	2,18	46,8	2,61	41,9	2,83	36,2	3,03	30,8	3,17
	18	-	-	46,4	3,06	46,4	3,06	46,4	3,06	40,2	3,29	34,2	3,46
	20	-	-	42,6	3,44	42,6	3,44	42,6	3,44	42,6	3,44	36,2	3,63

To = Internal exchanger outlet water temperature (°C)

Tae [°C] = External exchanger inlet air temperature

Performance calculated with the inlet/outlet water temperature difference = 5°C\*

\*Always check the actual temperature difference on the configurator, as it is linked to the minimum or maximum flow-rate limits of the exchanger

## Cooling - Size 20.1 - SC Version

TAIR DB [°C]	Tw [°C]	Entering external exchanger air temperature (°C)											
		100%		80%		70%		60%		50%		40%	
		Pcool	EER	Pcool	EER	Pcool	EER	Pcool	EER	Pcool	EER	Pcool	EER
<b>-10</b>	5	-	-	-	-	52,1	5,04	44,9	5,24	39,0	5,66	32,2	6,29
	7	-	-	-	-	56,8	5,43	48,5	5,57	42,2	6,00	35,0	6,71
	10	-	-	-	-	62,2	5,78	54,1	6,09	46,2	6,38	38,2	7,19
	12	-	-	-	-	65,6	5,96	57,5	6,42	48,8	6,64	40,4	7,52
	15	-	-	-	-	70,8	6,22	62,2	6,81	53,2	7,18	43,8	8,02
	18	-	-	-	-	76,6	6,48	67,8	7,17	59,0	7,81	48,2	8,63
	20	-	-	-	-	82,4	6,72	72,6	7,45	63,1	8,21	51,1	9,03
<b>15</b>	5	66,5	3,54	63,8	3,63	49,2	4,30	42,4	4,48	36,8	4,84	30,4	5,39
	7	70,7	3,67	68,0	3,77	53,6	4,63	45,7	4,76	39,9	5,13	33,0	5,75
	10	78,5	3,87	75,4	3,99	58,7	4,93	51,0	5,20	43,6	5,45	36,0	6,17
	12	82,5	3,96	79,3	4,09	61,9	5,08	54,3	5,48	46,0	5,68	38,1	6,45
	15	88,7	4,09	85,4	4,24	66,8	5,30	58,7	5,81	50,2	6,14	41,3	6,87
	18	95,0	4,20	91,6	4,37	72,3	5,52	64,0	6,12	55,7	6,67	45,5	7,40
	20	99,6	4,29	96,0	4,47	77,7	5,73	68,5	6,35	59,5	7,02	48,2	7,74
<b>20</b>	5	63,7	3,18	61,3	3,27	46,6	3,74	41,0	4,07	35,6	4,40	29,4	4,89
	7	68,0	3,31	65,4	3,41	50,2	3,92	44,4	4,31	38,6	4,68	31,9	5,24
	10	75,2	3,50	72,4	3,62	54,6	4,15	48,5	4,57	42,2	4,98	34,8	5,63
	12	79,1	3,60	76,2	3,72	59,1	4,47	51,1	4,72	44,5	5,18	36,9	5,89
	15	85,1	3,73	82,0	3,87	64,8	4,83	55,4	4,99	48,2	5,48	40,0	6,29
	18	91,3	3,85	88,1	4,00	69,9	5,06	61,5	5,45	52,9	5,82	44,1	6,80
	20	95,6	3,94	92,3	4,10	75,0	5,26	65,7	5,74	55,6	5,96	46,7	7,11
<b>25</b>	5	60,9	2,85	58,6	2,94	44,8	3,38	39,5	3,68	34,3	3,97	28,3	4,38
	7	65,2	2,98	62,9	3,08	48,4	3,56	42,8	3,89	37,3	4,23	30,8	4,71
	10	71,8	3,16	69,2	3,27	52,9	3,76	46,8	4,15	40,7	4,52	33,6	5,07
	12	75,6	3,25	72,9	3,37	55,7	3,88	49,4	4,30	43,0	4,71	35,6	5,32
	15	81,4	3,39	78,6	3,52	60,1	4,05	53,4	4,52	46,6	4,99	38,6	5,68
	18	87,5	3,51	84,6	3,66	64,5	4,20	58,3	4,77	51,2	5,32	42,6	6,16
	20	91,5	3,60	88,5	3,75	70,0	4,50	62,0	4,93	54,4	5,53	45,2	6,45
<b>30</b>	5	57,1	2,45	54,3	2,47	43,0	3,04	37,9	3,30	33,0	3,56	27,2	3,89
	7	62,5	2,65	59,5	2,68	46,5	3,21	41,2	3,51	35,9	3,80	29,6	4,19
	10	68,4	2,84	66,8	2,96	50,8	3,40	45,0	3,74	39,2	4,07	32,3	4,52
	12	72,0	2,93	69,5	3,04	53,5	3,52	47,5	3,89	41,4	4,24	34,2	4,75
	15	77,6	3,06	75,0	3,19	57,8	3,69	51,4	4,10	44,9	4,51	37,2	5,08
	18	83,8	3,20	81,1	3,33	63,0	3,88	56,3	4,34	49,4	4,82	41,1	5,52
	20	87,4	3,29	84,9	3,46	66,9	4,00	59,8	4,50	52,4	5,02	43,5	5,78

# Performances

## Cooling - Size 20.1 - SC Version

TAIR DB [°C]	To (°C)	Entering external exchanger air temperature (°C)											
		100%		80%		70%		60%		50%		40%	
		Pcool	EER	Pcool	EER	Pcool	EER	Pcool	EER	Pcool	EER	Pcool	EER
<b>35</b>	5	52,6	2,09	51,0	2,17	41,1	2,72	36,3	2,95	31,6	3,17	26,0	3,43
	7	58,3	2,36	54,9	2,39	44,5	2,88	39,5	3,14	34,4	3,39	28,3	3,70
	10	61,3	2,43	60,2	2,54	48,6	3,06	43,1	3,36	37,6	3,64	31,0	3,99
	12	67,4	2,53	64,3	2,57	51,2	3,17	45,5	3,50	39,7	3,80	32,8	4,19
	15	70,7	2,79	70,7	2,79	55,4	3,34	49,3	3,70	43,1	4,04	35,6	4,50
	18	64,8	3,43	62,9	3,33	60,6	3,52	54,2	3,94	47,6	4,35	38,5	4,80
	20	64,2	3,65	64,2	3,65	64,2	3,65	57,5	4,09	50,4	4,52	41,8	5,13
<b>40</b>	5	49,7	1,86	48,3	1,94	39,1	2,43	34,7	2,63	30,2	2,80	24,8	2,99
	7	53,5	1,96	52,1	2,05	42,4	2,58	37,7	2,80	32,9	3,01	27,0	3,23
	10	58,2	2,06	56,7	2,16	46,3	2,74	41,2	3,00	35,9	3,23	29,5	3,50
	12	61,3	2,13	59,7	2,24	48,9	2,85	43,5	3,13	38,0	3,38	31,3	3,68
	15	66,6	2,27	64,2	2,34	52,8	3,00	47,2	3,32	41,3	3,60	34,1	3,96
	18	58,0	3,19	58,0	3,19	58,0	3,19	52,0	3,55	45,7	3,89	37,8	4,31
	20	55,0	3,69	55,0	3,69	55,0	3,69	55,0	3,69	48,3	4,05	40,0	4,52
<b>44</b>	5	-	-	46,0	1,77	37,5	2,21	33,3	2,38	29,0	2,53	23,8	2,68
	7	-	-	49,7	1,87	40,7	2,35	36,2	2,55	31,6	2,72	25,9	2,89
	10	-	-	54,1	1,98	44,4	2,50	39,6	2,73	34,5	2,93	28,4	3,13
	12	-	-	57,0	2,05	46,9	2,60	41,8	2,85	36,6	3,07	30,1	3,29
	15	-	-	61,5	2,16	50,8	2,75	45,4	3,03	39,7	3,28	32,7	3,55
	18	-	-	55,8	2,94	55,8	2,94	50,1	3,25	44,0	3,55	36,3	3,87
	20	-	-	53,0	3,38	53,0	3,38	53,0	3,38	46,6	3,70	37,8	4,01
<b>48</b>	5	-	-	43,7	1,61	35,8	2,00	31,9	2,16	27,8	2,28	22,8	2,38
	7	-	-	47,3	1,70	37,8	2,09	34,7	2,31	30,3	2,45	24,8	2,57
	10	-	-	51,5	1,81	42,5	2,28	37,9	2,48	33,1	2,65	27,2	2,79
	12	-	-	54,3	1,88	44,9	2,37	40,1	2,59	35,1	2,77	28,8	2,94
	15	-	-	58,6	1,98	48,7	2,52	43,6	2,76	38,2	2,97	31,4	3,17
	18	-	-	48,2	2,97	48,2	2,97	48,2	2,97	42,4	3,22	34,9	3,46
	20	-	-	44,1	3,32	44,1	3,32	44,1	3,32	44,1	3,32	36,9	3,63

To = Internal exchanger outlet water temperature (°C)

Tae [°C] = External exchanger inlet air temperature

Performance calculated with the inlet/outlet water temperature difference = 5°C\*

\*Always check the actual temperature difference on the configurator, as it is linked to the minimum or maximum flow-rate limits of the exchanger

## Cooling - Size 25.2 - SC Version

TAIR DB [°C]	Tw [°C]	Entering external exchanger air temperature (°C)											
		100%		80%		70%		60%		50%		40%	
		Pcool	EER	Pcool	EER	Pcool	EER	Pcool	EER	Pcool	EER	Pcool	EER
<b>-10</b>	5	-	-	-	-	58,5	6,02	51,0	6,44	44,1	6,87	37,9	7,34
	7	-	-	-	-	63,4	6,47	55,4	6,96	48,1	7,48	41,4	8,05
	10	-	-	-	-	70,3	7,09	61,3	7,64	53,0	8,22	45,5	8,86
	12	-	-	-	-	74,4	7,44	65,0	8,07	56,2	8,71	48,4	9,41
	15	-	-	-	-	80,9	7,98	70,7	8,71	61,3	9,49	52,8	10,28
	18	-	-	-	-	88,6	8,58	77,8	9,48	67,8	10,45	56,9	11,11
	20	-	-	-	-	95,4	9,09	83,5	10,07	71,1	10,95	59,8	11,68
<b>15</b>	5	74,5	4,24	70,9	4,34	55,2	5,15	48,1	5,51	41,6	5,90	35,7	6,33
	7	79,9	4,48	76,2	4,60	59,8	5,54	52,3	5,96	45,4	6,42	39,1	6,93
	10	89,4	4,87	85,2	5,02	66,3	6,06	57,8	6,55	50,0	7,06	43,0	7,63
	12	94,5	5,07	90,2	5,24	70,2	6,36	61,3	6,91	53,1	7,48	45,6	8,10
	15	103	5,36	97,9	5,55	76,3	6,82	66,7	7,46	57,8	8,15	49,8	8,86
	18	111	5,63	106	5,86	83,6	7,34	73,4	8,12	64,0	8,97	53,7	9,57
	20	120	5,92	115	6,17	90,0	7,77	78,8	8,63	67,1	9,40	56,4	10,06
<b>20</b>	5	71,1	3,76	67,8	3,86	53,0	4,61	46,2	4,95	40,0	5,31	34,3	5,71
	7	76,5	3,99	73,0	4,11	57,5	4,97	50,3	5,38	43,7	5,81	37,6	6,28
	10	85,4	4,35	81,5	4,50	63,6	5,45	55,6	5,92	48,1	6,40	41,3	6,93
	12	90,4	4,54	86,3	4,70	67,4	5,74	59,0	6,26	51,0	6,81	43,9	7,39
	15	98,1	4,82	93,8	5,01	73,4	6,18	64,2	6,78	55,7	7,43	47,9	8,11
	18	106	5,09	102	5,31	80,6	6,68	70,8	7,42	61,7	8,22	53,3	9,07
	20	115	5,37	110	5,62	86,6	7,08	75,9	7,90	65,9	8,78	56,7	9,70
<b>25</b>	5	67,6	3,33	64,6	3,43	50,6	4,10	44,3	4,42	38,3	4,74	32,9	5,08
	7	73,0	3,55	69,8	3,67	55,2	4,44	48,3	4,82	41,9	5,20	36,0	5,60
	10	81,3	3,87	77,7	4,01	60,9	4,87	53,3	5,30	46,1	5,74	39,6	6,21
	12	86,1	4,06	82,3	4,21	64,7	5,15	56,6	5,62	49,0	6,11	42,1	6,63
	15	93,6	4,32	89,6	4,50	70,3	5,55	61,7	6,11	53,5	6,69	46,0	7,30
	18	102	4,60	97,7	4,81	77,5	6,05	68,2	6,72	59,4	7,44	51,2	8,21
	20	110	4,87	105,5	5,10	83,1	6,42	72,9	7,16	63,4	7,95	54,5	8,79
<b>30</b>	5	64,1	2,94	61,4	3,04	48,3	3,63	42,3	3,91	36,6	4,19	31,4	4,47
	7	69,3	3,14	66,5	3,26	52,7	3,95	46,2	4,28	38,9	4,48	34,4	4,94
	10	77,2	3,44	73,8	3,57	58,2	4,34	50,9	4,71	44,1	5,10	37,8	5,48
	12	81,8	3,61	78,3	3,75	61,8	4,59	54,1	5,01	46,9	5,44	40,2	5,87
	15	89,0	3,86	85,3	4,03	67,3	4,97	59,1	5,47	51,2	5,97	44,0	6,48
	18	97,4	4,15	93,5	4,34	74,4	5,44	65,6	6,06	57,0	6,68	49,1	7,32
	20	105	4,39	101	4,60	79,6	5,78	70,0	6,44	60,8	7,13	52,2	7,84

# Performances

## Cooling - Size 25.2 - SC Version

TAIR DB [°C]	To (°C)	Entering external exchanger air temperature (°C)											
		100%		80%		70%		60%		50%		40%	
		Pcool	EER	Pcool	EER	Pcool	EER	Pcool	EER	Pcool	EER	Pcool	EER
<b>35</b>	5	60,6	2,59	58,0	2,68	45,9	3,20	40,2	3,45	34,8	3,68	29,9	3,90
	7	67,9	2,87	63,2	2,89	50,2	3,50	44,1	3,78	38,2	4,06	32,7	4,31
	10	73,0	3,05	69,9	3,16	55,4	3,84	48,5	4,17	42,0	4,49	36,0	4,80
	12	77,5	3,20	74,3	3,34	58,8	4,07	51,6	4,44	44,7	4,80	38,4	5,14
	15	81,0	3,60	81,0	3,60	64,2	4,42	56,4	4,86	48,9	5,28	42,0	5,69
	18	80,0	4,27	77,7	4,15	71,2	4,87	62,8	5,40	54,6	5,93	47,0	6,45
	20	76,1	5,19	76,1	5,19	76,1	5,19	67,0	5,76	58,1	6,33	49,9	6,90
<b>40</b>	5	57,0	2,28	54,7	2,36	43,4	2,82	38,1	3,02	33,0	3,21	28,3	3,37
	7	62,2	2,46	59,8	2,56	47,7	3,08	41,8	3,33	36,2	3,54	31,0	3,73
	10	68,8	2,69	66,1	2,80	52,5	3,39	46,1	3,67	39,9	3,93	34,2	4,16
	12	73,1	2,84	70,2	2,96	55,9	3,60	49,1	3,92	42,5	4,20	36,4	4,47
	15	79,8	3,06	76,7	3,20	61,1	3,93	53,7	4,29	46,6	4,64	39,9	4,95
	18	68,0	4,35	68,0	4,35	68,0	4,35	60,0	4,80	52,1	5,23	44,7	5,62
	20	63,9	5,12	63,9	5,12	63,9	5,12	63,9	5,12	55,5	5,59	47,6	6,03
<b>44</b>	5	-	-	51,9	2,12	41,4	2,53	36,4	2,71	31,5	2,86	27,0	2,99
	7	-	-	56,9	2,31	43,8	2,67	40,0	2,98	34,6	3,16	29,6	3,31
	10	-	-	62,9	2,53	50,2	3,06	44,1	3,30	37,2	3,43	32,7	3,70
	12	-	-	66,9	2,68	53,4	3,25	47,0	3,52	40,7	3,77	34,8	3,97
	15	-	-	73,1	2,91	58,5	3,56	51,5	3,88	44,7	4,16	38,2	4,41
	18	-	-	65,3	3,96	65,3	3,96	57,6	4,35	50,0	4,70	42,9	5,01
	20	-	-	61,4	4,64	61,4	4,64	61,4	4,64	53,3	5,03	45,6	5,37
<b>48</b>	5	-	-	49,1	1,91	39,4	2,27	34,7	2,42	30,0	2,55	25,7	2,64
	7	-	-	54,0	2,08	41,6	2,40	38,1	2,67	33,0	2,82	28,2	2,92
	10	-	-	59,7	2,29	47,8	2,75	42,1	2,96	36,5	3,14	31,1	3,27
	12	-	-	63,6	2,42	51,0	2,93	44,9	3,17	38,9	3,36	33,2	3,51
	15	-	-	69,6	2,64	55,9	3,21	49,3	3,49	42,7	3,72	36,5	3,90
	18	-	-	55,3	3,93	55,3	3,93	55,3	3,93	47,9	4,21	41,0	4,44
	20	-	-	51,1	4,51	51,1	4,51	51,1	4,51	51,1	4,51	43,7	4,77

To = Internal exchanger outlet water temperature (°C)

Tae [°C] = External exchanger inlet air temperature

Performance calculated with the inlet/outlet water temperature difference = 5°C\*

\*Always check the actual temperature difference on the configurator, as it is linked to the minimum or maximum flow-rate limits of the exchanger

## Cooling - Size 30.2 - SC Version

TAIR DB [°C]	Tw [°C]	Entering external exchanger air temperature (°C)											
		100%		80%		70%		60%		50%		40%	
		Pcool	EER	Pcool	EER	Pcool	EER	Pcool	EER	Pcool	EER	Pcool	EER
<b>-10</b>	5	-	-	-	-	64,2	5,75	56,0	6,16	48,4	6,58	39,8	7,28
	7	-	-	-	-	69,3	6,14	60,8	6,63	52,7	7,14	43,5	7,97
	10	-	-	-	-	76,9	6,69	67,3	7,26	58,2	7,85	47,8	8,78
	12	-	-	-	-	81,4	7,00	71,3	7,64	61,8	8,30	50,8	9,32
	15	-	-	-	-	88,5	7,47	77,6	8,21	67,3	8,99	55,4	10,2
	18	-	-	-	-	96,5	7,97	85,0	8,86	74,1	9,82	60,1	11,1
	20	-	-	-	-	104,1	8,42	91,5	9,40	79,4	10,45	63,0	11,6
<b>15</b>	5	81,3	4,03	77,3	4,15	60,5	4,91	52,9	5,27	45,7	5,64	37,5	6,27
	7	87,0	4,24	82,8	4,38	65,4	5,24	57,4	5,67	49,7	6,12	41,0	6,86
	10	97,4	4,58	92,6	4,76	72,6	5,71	63,5	6,22	54,9	6,73	45,1	7,56
	12	103	4,75	98,0	4,94	76,8	5,98	67,3	6,54	58,3	7,11	47,9	8,03
	15	111	4,98	106	5,21	83,5	6,38	73,2	7,02	63,5	7,71	52,3	8,77
	18	120	5,20	115	5,46	91,0	6,81	80,2	7,58	69,9	8,42	56,7	9,53
	20	126	5,37	121	5,65	98,2	7,19	86,3	8,04	74,9	8,96	59,4	10,0
<b>20</b>	5	77,4	3,55	73,7	3,68	58,0	4,38	50,7	4,72	43,9	5,08	36,1	5,66
	7	83,0	3,75	79,2	3,89	62,8	4,69	55,2	5,10	47,9	5,53	39,5	6,22
	10	92,8	4,07	88,4	4,24	69,5	5,12	61,0	5,60	52,8	6,09	43,4	6,86
	12	98,1	4,23	93,5	4,42	73,7	5,38	64,7	5,91	56,0	6,45	46,1	7,32
	15	106	4,46	101	4,67	80,1	5,76	70,4	6,37	61,1	7,01	50,3	8,03
	18	115	4,68	110	4,92	87,7	6,18	77,4	6,92	67,4	7,70	55,9	8,99
	20	121	4,84	115	5,10	94,4	6,54	83,1	7,34	72,2	8,20	59,6	9,61
<b>25</b>	5	73,4	3,13	70,0	3,25	55,4	3,88	48,6	4,20	42,0	4,53	34,5	5,04
	7	79,0	3,32	75,4	3,45	60,2	4,19	52,9	4,56	46,0	4,95	37,8	5,55
	10	88,1	3,61	84,1	3,77	66,6	4,58	58,4	5,01	50,6	5,45	41,6	6,15
	12	93,2	3,76	89,1	3,94	70,5	4,81	62,0	5,29	53,8	5,79	44,2	6,56
	15	101	3,99	96,7	4,19	76,7	5,17	67,5	5,73	58,7	6,32	48,3	7,23
	18	110	4,21	105	4,44	84,2	5,59	74,5	6,26	65,0	6,99	53,8	8,13
	20	115	4,36	110	4,60	90,5	5,92	79,8	6,65	69,5	7,45	57,2	8,71
<b>30</b>	5	69,3	2,75	66,2	2,86	52,7	3,44	46,3	3,72	40,2	4,01	33,0	4,43
	7	74,8	2,93	71,6	3,06	57,4	3,72	50,6	4,06	44,0	4,40	36,1	4,90
	10	83,3	3,19	79,7	3,34	63,5	4,07	55,8	4,46	48,4	4,85	39,7	5,43
	12	88,3	3,34	84,5	3,50	67,3	4,29	59,3	4,72	51,4	5,16	42,3	5,82
	15	96,0	3,55	91,9	3,74	73,3	4,62	64,6	5,13	56,2	5,65	46,2	6,42
	18	104	3,78	100	3,99	80,7	5,03	71,5	5,63	62,4	6,28	51,6	7,25
	20	110	3,92	105	4,14	86,6	5,33	76,5	5,99	66,6	6,69	54,9	7,77

# Performances

## Cooling - Size 30.2 - SC Version

TAIR DB [°C]	To (°C)	Entering external exchanger air temperature (°C)											
		100%		80%		70%		60%		50%		40%	
		Pcool	EER	Pcool	EER	Pcool	EER	Pcool	EER	Pcool	EER	Pcool	EER
35	5	65,2	2,41	62,5	2,52	50,0	3,03	44,0	3,28	38,2	3,53	31,4	3,86
	7	72,8	2,66	67,8	2,70	54,6	3,29	48,2	3,59	40,3	3,74	34,4	4,27
	10	78,6	2,82	75,3	2,95	60,3	3,60	53,1	3,95	46,1	4,29	37,8	4,75
	12	83,3	2,95	79,9	3,10	64,1	3,81	56,5	4,19	49,1	4,57	40,3	5,09
	15	87,0	3,33	87,0	3,33	69,8	4,12	61,7	4,57	53,7	5,01	44,1	5,64
	18	86,2	3,94	83,7	3,82	77,2	4,51	68,4	5,04	59,8	5,59	49,3	6,39
	20	82,6	4,79	82,6	4,79	82,6	4,79	73,1	5,37	63,7	5,97	52,4	6,84
40	5	61,2	2,11	58,7	2,21	47,2	2,66	41,7	2,88	36,2	3,09	29,7	3,34
	7	66,6	2,27	64,0	2,38	51,8	2,90	45,8	3,16	39,8	3,40	32,5	3,70
	10	73,7	2,48	70,8	2,60	57,1	3,18	50,4	3,48	43,8	3,77	35,9	4,12
	12	78,3	2,60	75,2	2,74	60,7	3,37	53,7	3,70	46,7	4,02	38,2	4,43
	15	85,4	2,80	82,1	2,96	66,3	3,66	58,7	4,05	51,1	4,42	41,9	4,91
	18	73,5	4,03	73,5	4,03	73,5	4,03	65,4	4,50	57,1	4,96	46,9	5,57
	20	69,8	4,79	69,8	4,79	69,8	4,79	69,8	4,79	60,8	5,29	49,9	5,97
44	5	-	-	55,6	1,98	45,0	2,39	39,8	2,59	34,6	2,77	28,3	2,96
	7	-	-	60,8	2,15	49,4	2,61	43,7	2,85	38,0	3,05	31,1	3,28
	10	-	-	67,3	2,35	54,5	2,87	48,2	3,14	41,9	3,38	34,3	3,66
	12	-	-	71,5	2,48	58,0	3,05	51,4	3,34	44,7	3,62	36,6	3,93
	15	-	-	78,2	2,68	63,5	3,32	56,3	3,66	49,0	3,98	40,2	4,36
	18	-	-	70,6	3,67	70,6	3,67	62,9	4,09	54,9	4,48	45,0	4,96
	20	-	-	67,0	4,35	67,0	4,35	67,0	4,35	58,4	4,78	47,9	5,32
48	5	-	-	52,4	1,78	42,7	2,14	37,9	2,32	33,0	2,47	26,9	2,61
	7	-	-	57,6	1,93	45,2	2,26	41,6	2,55	36,2	2,73	29,6	2,89
	10	-	-	63,7	2,12	51,9	2,59	46,0	2,82	39,0	2,95	32,7	3,24
	12	-	-	67,7	2,23	55,3	2,75	49,0	3,01	42,7	3,24	34,9	3,48
	15	-	-	74,1	2,42	60,6	3,00	53,8	3,30	46,9	3,58	38,3	3,86
	18	-	-	60,3	3,70	60,3	3,70	60,3	3,70	52,6	4,03	43,0	4,40
	20	-	-	56,0	4,31	56,0	4,31	56,0	4,31	56,0	4,31	45,9	4,72

To = Internal exchanger outlet water temperature (°C)

Tae [°C] = External exchanger inlet air temperature

Performance calculated with the inlet/outlet water temperature difference = 5°C\*

\*Always check the actual temperature difference on the configurator, as it is linked to the minimum or maximum flow-rate limits of the exchanger

## Heating - Size 14.1 - SC Version

Ta (°C) D.B./W.B.	Tw [°C]	Hot side exchanger outlet water temperature (°C)											
		100%		80%		70%		60%		50%		40%	
		Pheat	COP	Pheat	COP	Pheat	COP	Pheat	COP	Pheat	COP	Pheat	COP
<b>-20/-21</b>	25	-	-	-	-	-	-	13,4	2,67	11,2	2,70	9,11	2,56
	35	-	-	-	-	-	-	13,2	2,26	11,1	2,26	9,03	2,15
	40	-	-	-	-	-	-	13,1	2,09	11,1	2,08	9,02	1,98
	45	-	-	-	-	-	-	13,1	1,93	11,1	1,91	9,01	1,82
	55	-	-	-	-	-	-	13,0	1,64	11,0	1,62	8,56	1,48
	60	-	-	-	-	-	-	-	-	-	-	-	-
	65	-	-	-	-	-	-	-	-	-	-	-	-
	70	-	-	-	-	-	-	-	-	-	-	-	-
	75	-	-	-	-	-	-	-	-	-	-	-	-
<b>-15/-16</b>	25	-	-	-	-	18,0	3,00	15,6	3,05	13,1	3,10	10,1	2,99
	35	-	-	-	-	17,6	2,53	15,3	2,57	12,9	2,60	9,89	2,46
	40	-	-	-	-	17,4	2,33	15,1	2,36	12,8	2,37	9,84	2,24
	45	-	-	-	-	17,3	2,14	15,0	2,17	12,7	2,17	9,80	2,03
	55	-	-	-	-	16,9	1,81	14,8	1,83	12,6	1,82	9,73	1,68
	60	-	-	-	-	16,9	1,68	14,8	1,69	12,5	1,68	9,71	1,54
	65	-	-	-	-	16,8	1,56	14,7	1,57	12,5	1,54	9,71	1,41
	70	-	-	-	-	-	-	-	-	-	-	-	-
	75	-	-	-	-	-	-	-	-	-	-	-	-
<b>-10/-11</b>	25	29,1	2,99	25,0	3,21	20,8	3,43	18,1	3,51	15,3	3,59	11,8	3,48
	35	28,2	2,53	24,2	2,70	20,2	2,87	17,6	2,93	14,8	2,99	11,4	2,87
	40	27,8	2,32	23,9	2,47	20,0	2,63	17,4	2,68	14,7	2,72	11,3	2,60
	45	27,5	2,15	23,6	2,28	19,7	2,41	17,2	2,45	14,5	2,48	11,2	2,35
	55	23,8	1,84	21,5	1,93	19,2	2,01	16,7	2,05	14,2	2,06	11,0	1,93
	60	23,4	1,70	21,2	1,78	19,0	1,85	16,6	1,88	14,2	1,89	11,0	1,75
	65	23,1	1,57	20,9	1,64	18,8	1,71	16,5	1,74	14,1	1,73	10,9	1,59
	70	-	-	-	-	18,7	1,58	16,4	1,60	14,0	1,59	10,8	1,45
	75	-	-	-	-	-	-	-	-	-	-	-	-
<b>-7/-8</b>	25	31,5	3,24	27,1	3,48	22,6	3,72	19,7	3,82	16,7	3,91	12,9	3,82
	35	30,5	2,71	26,2	2,91	22,0	3,10	19,1	3,18	16,2	3,26	12,5	3,14
	40	30,0	2,48	25,8	2,66	21,6	2,83	18,8	2,90	15,9	2,96	12,3	2,84
	45	29,6	2,29	25,5	2,44	21,3	2,59	18,6	2,65	15,7	2,69	12,1	2,57
	55	25,6	1,96	23,1	2,06	20,7	2,15	18,0	2,20	15,3	2,22	11,9	2,09
	60	25,2	1,80	22,8	1,89	20,4	1,97	17,8	2,01	15,2	2,03	11,8	1,90
	65	24,8	1,66	22,4	1,74	20,1	1,81	17,6	1,84	15,1	1,86	11,7	1,72
	70	-	-	-	-	19,9	1,67	17,5	1,70	14,9	1,70	11,6	1,56
	75	-	-	-	-	17,4	1,57	17,4	1,57	14,8	1,56	11,5	1,42
<b>2/1</b>	25	32,7	4,11	31,5	5,13	28,5	5,03	25,5	4,93	21,6	5,10	16,7	5,03
	35	35,0	3,49	31,6	3,71	28,1	3,94	24,5	4,08	20,7	4,22	16,0	4,15
	40	37,9	3,05	32,7	3,32	27,5	3,58	24,0	3,71	20,3	3,82	15,7	3,73
	45	37,1	2,78	32,0	3,02	27,0	3,26	23,5	3,36	19,9	3,46	15,4	3,36
	55	31,7	2,36	28,7	2,50	25,7	2,65	22,4	2,74	19,1	2,80	14,8	2,68
	60	31,0	2,15	28,1	2,28	25,2	2,41	22,0	2,48	18,7	2,53	14,5	2,41
	65	30,3	1,97	27,5	2,08	24,7	2,19	21,6	2,26	18,4	2,30	14,3	2,16
	70	-	-	-	-	24,2	1,99	21,2	2,05	18,1	2,08	13,9	2,03
	75	-	-	-	-	20,8	1,86	20,8	1,86	17,8	1,89	13,6	1,87
<b>7/6</b>	25	33,8	5,48	30,6	5,65	31,7	5,59	29,5	5,71	25,1	5,95	19,4	5,91
	35	40,1	3,94	40,1	3,95	32,3	4,52	28,2	4,72	23,9	4,93	18,4	4,87
	40	43,4	3,43	39,2	3,58	31,5	4,09	27,5	4,28	23,3	4,46	18,0	4,38
	45	39,8	3,12	38,2	3,26	30,9	3,72	26,9	3,88	22,8	4,01	17,5	3,91
	55	36,9	2,71	35,9	2,64	29,1	3,00	25,5	3,12	21,6	3,22	16,7	3,09
	60	35,0	2,41	35,0	2,41	28,4	2,72	24,9	2,82	21,1	2,89	16,3	2,76
	65	34,1	2,20	34,1	2,20	27,7	2,46	24,3	2,55	20,7	2,60	16,0	2,46
	70	-	-	-	-	27,1	2,23	23,8	2,30	20,2	2,34	15,7	2,20
	75	-	-	-	-	23,2	2,07	23,2	2,07	19,8	2,10	15,4	1,97

# Performances

## Heating - Size 14.1 - SC Version

Ta (°C) D.B./W.B.	Tw [°C]	Hot side exchanger outlet water temperature (°C)											
		100%		80%		70%		60%		50%		40%	
		Pheat	COP	Pheat	COP	Pheat	COP	Pheat	COP	Pheat	COP	Pheat	COP
10/9	25	50,3	4,94	43,6	5,44	36,9	5,94	32,2	6,21	27,4	6,51	21,3	6,52
	35	47,8	4,04	41,4	4,47	35,1	4,90	30,6	5,16	26,0	5,41	20,1	5,38
	40	46,6	3,66	40,4	4,05	34,2	4,44	29,9	4,67	25,3	4,89	19,6	4,82
	45	45,4	3,33	39,4	3,68	33,4	4,03	29,2	4,23	24,7	4,40	19,1	4,31
	55	38,6	2,84	35,0	3,04	31,4	3,23	27,5	3,39	23,4	3,51	18,1	3,39
	60	37,6	2,59	34,1	2,76	30,6	2,92	26,8	3,05	22,8	3,15	17,6	3,01
	65	36,8	2,39	33,3	2,51	29,8	2,64	26,2	2,75	22,3	2,82	17,2	2,68
	70	-	-	-	-	29,0	2,40	25,5	2,48	21,7	2,53	16,8	2,38
	75	-	-	-	-	24,8	2,23	24,8	2,23	21,2	2,26	16,4	2,12
18/12	25	58,6	5,65	50,8	6,25	43,1	6,84	38,2	7,32	32,8	7,87	25,8	8,05
	35	55,8	4,66	48,4	5,18	41,1	5,69	36,3	6,12	31,2	6,59	24,4	6,73
	40	54,4	4,23	47,2	4,70	40,1	5,18	35,4	5,57	30,4	5,96	23,8	6,06
	45	53,0	3,86	46,1	4,28	39,1	4,70	34,5	5,04	29,6	5,39	23,1	5,41
	55	45,5	3,35	41,1	3,57	36,8	3,79	32,5	4,04	27,9	4,27	21,8	4,23
	60	44,2	3,06	40,0	3,26	35,9	3,45	31,6	3,63	27,2	3,82	21,2	3,73
	65	42,9	2,80	38,9	2,97	35,0	3,14	30,8	3,27	26,5	3,42	20,6	3,30
	70	-	-	-	-	34,1	2,86	30,0	2,96	25,8	3,05	20,1	2,92
	75	-	-	-	-	29,3	2,69	29,3	2,69	25,1	2,73	19,5	2,57
42/31	25	-	-	-	-	59,9	9,24	53,0	9,95	45,5	10,8	34,6	12,7
	35	-	-	-	-	56,7	7,61	50,0	8,33	42,8	9,21	32,4	11,0
	40	-	-	-	-	55,1	6,87	48,5	7,55	41,5	8,35	31,3	9,91
	45	-	-	-	-	53,5	6,21	47,1	6,82	40,2	7,52	30,2	8,79
	55	-	-	-	-	-	-	-	-	-	-	-	-
	60	-	-	-	-	-	-	-	-	-	-	-	-
	65	-	-	-	-	-	-	-	-	-	-	-	-
	70	-	-	-	-	-	-	-	-	-	-	-	-
	75	-	-	-	-	-	-	-	-	-	-	-	-

To = Internal exchanger outlet water temperature (°C)

Tae [°C] = External exchanger inlet air temperature

Performance calculated with the inlet/outlet water temperature difference = 5°C\*

\*Always check the actual temperature difference on the configurator, as it is linked to the minimum or maximum flow-rate limits of the exchanger

### Integrated heating capacities

External exchanger inlet air temperature °C (D.B. / W.B.)	-7 / -8	-5 / -6	0 / -1	2 / 1	Others
heating capacity multiplication coefficient	0,93	0,93	0,93	0,93	0,93

The integrated heating capacity is the actual heating capacity, including the impact of any defrosting cycles.

This is obtained by multiplying the thermal capacity supplied kWt (given in the heating performance tables) by the coefficients in the table.

During prolonged heat pump operating mode with negative ambient temperature, it is important to encourage the evacuation of water produced by the defrosting cycles to avoid the build-up of ice near the unit's base. Be careful to ensure that this does not constitute a danger to objects or people.

## Heating - Size 16.1 - SC Version

Ta (°C) D.B./W.B.	Tw [°C]	Hot side exchanger outlet water temperature (°C)											
		100%		80%		70%		60%		50%		40%	
		Pheat	COP	Pheat	COP	Pheat	COP	Pheat	COP	Pheat	COP	Pheat	COP
<b>-20/-21</b>	25	-	-	-	-	-	-	14,1	2,65	11,9	2,69	9,59	2,70
	35	-	-	-	-	-	-	13,9	2,25	11,8	2,26	9,51	2,26
	40	-	-	-	-	-	-	13,8	2,08	11,8	2,09	9,49	2,08
	45	-	-	-	-	-	-	13,8	1,92	11,7	1,92	9,48	1,91
	55	-	-	-	-	-	-	13,6	1,64	11,7	1,63	9,01	1,55
	60	-	-	-	-	-	-	-	-	-	-	-	-
	65	-	-	-	-	-	-	-	-	-	-	-	-
	70	-	-	-	-	-	-	-	-	-	-	-	-
	75	-	-	-	-	-	-	-	-	-	-	-	-
<b>-15/-16</b>	25	-	-	-	-	19,1	2,96	16,4	3,04	13,9	3,09	10,6	3,14
	35	-	-	-	-	18,7	2,50	16,0	2,56	13,7	2,59	10,4	2,59
	40	-	-	-	-	18,5	2,30	15,9	2,35	13,6	2,37	10,4	2,35
	45	-	-	-	-	18,3	2,12	15,8	2,16	13,5	2,17	10,3	2,14
	55	-	-	-	-	17,9	1,80	15,6	1,83	13,3	1,83	10,2	1,77
	60	-	-	-	-	17,8	1,67	15,5	1,69	13,3	1,69	10,2	1,62
	65	-	-	-	-	17,7	1,55	15,4	1,57	13,2	1,55	10,2	1,48
	70	-	-	-	-	-	-	-	-	-	-	-	-
	75	-	-	-	-	-	-	-	-	-	-	-	-
<b>-10/-11</b>	25	30,5	2,95	26,3	3,17	22,0	3,39	19,0	3,48	16,2	3,56	12,4	3,66
	35	29,6	2,49	25,5	2,66	21,4	2,84	18,5	2,91	15,8	2,97	12,0	3,02
	40	29,2	2,29	25,1	2,44	21,1	2,60	18,2	2,67	15,6	2,71	11,9	2,73
	45	28,8	2,11	24,8	2,25	20,9	2,38	18,0	2,44	15,4	2,48	11,8	2,47
	55	27,5	1,76	23,9	1,88	20,2	2,00	17,6	2,04	15,1	2,06	11,6	2,03
	60	27,1	1,63	23,6	1,73	20,0	1,84	17,4	1,88	15,0	1,89	11,5	1,85
	65	26,6	1,50	23,2	1,60	19,8	1,69	17,3	1,73	14,9	1,74	11,5	1,68
	70	-	-	-	-	19,7	1,57	17,2	1,60	14,8	1,60	11,4	1,53
	75	-	-	-	-	-	-	-	-	-	-	-	-
<b>-7/-8</b>	25	33,0	3,19	28,5	3,43	23,9	3,67	20,7	3,78	17,7	3,88	13,6	4,02
	35	31,9	2,67	27,6	2,86	23,2	3,06	20,1	3,15	17,1	3,23	13,1	3,30
	40	31,4	2,44	27,1	2,62	22,9	2,80	19,8	2,88	16,9	2,94	12,9	2,99
	45	30,9	2,25	26,7	2,40	22,5	2,56	19,5	2,63	16,7	2,68	12,8	2,70
	55	29,5	1,86	25,7	1,99	21,8	2,13	18,9	2,18	16,2	2,22	12,5	2,20
	60	29,0	1,71	25,3	1,83	21,5	1,95	18,7	2,00	16,1	2,03	12,4	2,00
	65	28,5	1,58	24,8	1,69	21,2	1,79	18,5	1,84	15,9	1,85	12,3	1,81
	70	-	-	-	-	20,9	1,65	18,4	1,70	15,8	1,70	12,2	1,64
	75	-	-	-	-	18,2	1,56	18,2	1,56	15,7	1,56	12,1	1,50
<b>2/1</b>	25	34,3	4,05	32,6	4,38	30,9	4,70	26,8	4,88	22,9	5,05	17,6	5,29
	35	40,5	3,30	35,1	3,59	29,7	3,88	25,7	4,04	22,0	4,17	16,9	4,37
	40	39,6	2,99	34,3	3,25	29,1	3,52	25,2	3,67	21,5	3,79	16,5	3,93
	45	38,7	2,73	33,6	2,97	28,5	3,21	24,6	3,33	21,1	3,43	16,2	3,53
	55	36,5	2,21	31,8	2,41	27,1	2,60	23,5	2,71	20,2	2,79	15,5	2,83
	60	35,6	2,03	31,1	2,20	26,5	2,37	23,1	2,46	19,8	2,52	15,3	2,53
	65	34,8	1,86	30,4	2,01	26,0	2,16	22,6	2,24	19,5	2,29	15,0	2,28
	70	-	-	-	-	25,4	1,97	22,2	2,03	19,2	2,07	14,6	2,14
	75	-	-	-	-	21,8	1,85	21,8	1,85	18,9	1,88	14,3	1,97
<b>7/6</b>	25	35,7	5,38	32,1	5,57	33,3	5,50	31,0	5,63	26,6	5,86	20,5	6,22
	35	46,7	3,73	40,4	4,08	34,1	4,43	29,6	4,65	25,3	4,86	19,4	5,12
	40	45,0	3,33	39,1	3,67	33,3	4,01	28,9	4,22	24,7	4,40	18,9	4,61
	45	45,2	3,09	38,8	3,37	32,5	3,64	28,2	3,83	24,1	3,97	18,5	4,11
	55	42,8	2,58	36,8	2,76	30,7	2,94	26,7	3,09	22,9	3,19	17,6	3,25
	60	40,4	2,28	35,2	2,47	30,0	2,66	26,1	2,79	22,4	2,88	17,2	2,90
	65	39,2	2,08	34,2	2,25	29,2	2,41	25,5	2,52	21,9	2,59	16,8	2,59
	70	-	-	-	-	28,5	2,19	24,9	2,28	21,4	2,34	16,5	2,32
	75	-	-	-	-	24,3	2,05	24,3	2,05	21,0	2,10	16,2	2,08

# Performances

## Heating - Size 16.1 - SC Version

Ta (°C) D.B./W.B.	Tw [°C]	Hot side exchanger outlet water temperature (°C)											
		100%		80%		70%		60%		50%		40%	
		Pheat	COP	Pheat	COP	Pheat	COP	Pheat	COP	Pheat	COP	Pheat	COP
10/9	25	52,6	4,88	45,7	5,35	38,9	5,83	33,8	6,13	29,0	6,41	22,4	6,86
	35	50,0	3,97	43,5	4,38	37,0	4,79	32,1	5,07	27,6	5,32	21,2	5,66
	40	48,7	3,59	42,4	3,96	36,1	4,34	31,3	4,59	26,9	4,82	20,6	5,08
	45	47,5	3,26	41,3	3,60	35,2	3,94	30,6	4,16	26,2	4,36	20,1	4,54
	55	44,4	2,66	38,8	2,91	33,1	3,16	28,9	3,34	24,8	3,48	19,0	3,57
	60	43,2	2,43	37,7	2,64	32,2	2,86	28,1	3,01	24,2	3,12	18,5	3,17
	65	41,9	2,22	36,6	2,40	31,4	2,59	27,4	2,72	23,6	2,80	18,1	2,82
	70	-	-	-	-	30,6	2,36	26,7	2,45	23,0	2,52	17,7	2,51
	75	-	-	-	-	26,0	2,22	26,0	2,22	22,4	2,26	17,3	2,23
18/12	25	61,0	5,54	53,1	6,10	45,2	6,65	39,8	7,16	34,6	7,68	27,2	8,47
	35	58,2	4,55	50,6	5,03	43,1	5,52	37,9	5,97	32,9	6,43	25,7	7,08
	40	56,7	4,13	49,4	4,57	42,1	5,01	37,0	5,43	32,1	5,83	25,0	6,38
	45	55,3	3,76	48,2	4,17	41,0	4,57	36,1	4,92	31,3	5,27	24,3	5,70
	55	51,8	3,09	45,2	3,40	38,7	3,71	34,0	3,95	29,5	4,20	22,9	4,45
	60	50,3	2,82	44,0	3,10	37,7	3,38	33,1	3,56	28,7	3,77	22,3	3,93
	65	48,8	2,58	42,8	2,83	36,7	3,08	32,2	3,23	28,0	3,38	21,7	3,48
	70	-	-	-	-	35,8	2,81	31,4	2,94	27,2	3,02	21,1	3,07
	75	-	-	-	-	30,6	2,66	30,6	2,66	26,6	2,72	20,6	2,71
42/31	25	-	-	-	-	62,9	8,98	55,3	9,71	48,0	10,51	36,1	14,03
	35	-	-	-	-	59,6	7,34	52,3	8,08	45,2	8,89	33,7	12,12
	40	-	-	-	-	57,9	6,61	50,7	7,30	43,9	8,06	32,6	10,90
	45	-	-	-	-	56,2	5,98	49,3	6,61	42,6	7,27	31,5	9,63
	55	-	-	-	-	-	-	-	-	-	-	-	-
	60	-	-	-	-	-	-	-	-	-	-	-	-
	65	-	-	-	-	-	-	-	-	-	-	-	-
	70	-	-	-	-	-	-	-	-	-	-	-	-
	75-	-	-	-	-	-	-	-	-	-	-	-	-

To = Internal exchanger outlet water temperature (°C)

Tae [°C] = External exchanger inlet air temperature

Performance calculated with the inlet/outlet water temperature difference = 5°C\*

\*Always check the actual temperature difference on the configurator, as it is linked to the minimum or maximum flow-rate limits of the exchanger

### Integrated heating capacities

External exchanger inlet air temperature °C (D.B. / W.B.)	15/-16	-10/-11	-7/-8	2 / 1	Others
heating capacity multiplication coefficient	0,93	0,93	0,93	0,92	0,93

The integrated heating capacity is the actual heating capacity, including the impact of any defrosting cycles.

This is obtained by multiplying the thermal capacity supplied kWt (given in the heating performance tables) by the coefficients in the table.

During prolonged heat pump operating mode with negative ambient temperature, it is important to encourage the evacuation of water produced by the defrosting cycles to avoid the build-up of ice near the unit's base. Be careful to ensure that this does not constitute a danger to objects or people.

## Heating - Size 18.1 - SC Version

Ta (°C) D.B./W.B.	Tw [°C]	Hot side exchanger outlet water temperature (°C)											
		100%		80%		70%		60%		50%		40%	
		Pheat	COP	Pheat	COP	Pheat	COP	Pheat	COP	Pheat	COP	Pheat	COP
<b>-20/-21</b>	25	-	-	-	-	-	-	19,0	2,71	16,0	2,75	13,7	2,72
	35	-	-	-	-	-	-	19,2	2,29	16,4	2,30	14,1	2,26
	40	-	-	-	-	-	-	19,5	2,15	16,7	2,14	14,4	2,10
	45	-	-	-	-	-	-	19,4	1,94	16,8	1,93	14,6	1,90
	55	-	-	-	-	-	-	19,6	1,64	17,2	1,63	15,0	1,60
	60	-	-	-	-	-	-	-	-	-	-	-	-
	65	-	-	-	-	-	-	-	-	-	-	-	-
	70	-	-	-	-	-	-	-	-	-	-	-	-
	75	-	-	-	-	-	-	-	-	-	-	-	-
<b>-15/-16</b>	25	-	-	-	-	25,0	2,91	21,5	2,97	18,2	3,04	15,8	3,07
	35	-	-	-	-	24,9	2,47	21,9	2,53	18,4	2,54	15,9	2,52
	40	-	-	-	-	25,4	2,37	22,3	2,40	18,7	2,38	16,1	2,33
	45	-	-	-	-	24,9	2,10	22,1	2,14	18,9	2,14	16,3	2,10
	55	-	-	-	-	24,8	1,76	22,1	1,79	19,2	1,79	16,8	1,77
	60	-	-	-	-	24,9	1,64	21,9	1,64	19,4	1,65	17,0	1,63
	65	-	-	-	-	25,0	1,54	22,4	1,54	19,6	1,53	17,2	1,51
	70	-	-	-	-	-	-	-	-	-	-	-	-
	75	-	-	-	-	-	-	-	-	-	-	-	-
<b>-10/-11</b>	25	38,7	2,81	34,1	3,24	27,9	3,17	24,2	3,26	21,0	3,41	18,3	3,45
	35	38,7	2,46	33,7	2,75	28,3	2,71	24,3	2,74	20,9	2,82	18,2	2,84
	40	38,9	2,23	34,5	2,71	28,9	2,63	24,8	2,63	21,0	2,64	18,3	2,63
	45	38,3	2,13	33,4	2,35	28,2	2,30	24,8	2,34	20,9	2,34	18,2	2,33
	55	30,7	1,86	29,3	1,88	27,8	1,91	24,7	1,94	21,3	1,96	18,4	1,92
	60	30,7	1,74	29,2	1,76	27,8	1,78	24,8	1,79	21,5	1,80	18,7	1,77
	65	30,6	1,63	29,2	1,65	27,8	1,66	24,9	1,67	21,6	1,66	18,9	1,63
	70	-	-	-	-	27,8	1,56	24,9	1,56	21,8	1,54	19,1	1,51
	75	-	-	-	-	-	-	-	-	-	-	-	-
<b>-7/-8</b>	25	42,0	3,01	36,9	3,45	30,2	3,36	26,4	3,48	22,8	3,64	19,8	3,70
	35	42,0	2,63	36,4	2,92	30,6	2,88	26,4	2,93	22,5	3,01	19,7	3,04
	40	42,3	2,41	37,2	2,87	31,1	2,80	26,9	2,82	22,7	2,83	19,8	2,83
	45	41,4	2,25	36,0	2,49	30,3	2,42	26,2	2,45	22,5	2,49	19,6	2,49
	55	32,9	1,96	31,3	1,99	29,7	2,01	26,4	2,04	22,5	2,05	19,5	2,02
	60	32,8	1,83	31,2	1,85	29,7	1,87	26,4	1,89	22,8	1,89	19,7	1,85
	65	32,6	1,71	31,1	1,73	29,6	1,75	26,4	1,76	23,0	1,74	19,9	1,71
	70	-	-	-	-	29,6	1,63	26,4	1,64	23,0	1,62	20,1	1,58
	75	-	-	-	-	26,4	1,52	26,4	1,52	23,1	1,51	20,2	1,47
<b>2/1</b>	25	43,5	3,68	41,2	4,33	37,6	4,29	34,0	4,25	29,5	4,51	25,8	4,60
	35	44,0	3,40	47,3	3,66	37,9	3,44	33,2	3,53	28,8	3,72	25,1	3,77
	40	51,3	2,85	49,1	3,24	38,4	3,35	33,6	3,44	28,9	3,55	25,1	3,56
	45	52,2	2,72	46,2	3,08	37,8	2,92	32,6	2,93	28,2	3,04	24,5	3,06
	55	40,8	2,34	38,8	2,38	36,8	2,42	32,1	2,43	27,4	2,43	23,9	2,41
	60	40,3	2,16	38,4	2,19	36,4	2,23	32,1	2,25	27,3	2,22	23,8	2,19
	65	39,8	2,00	38,0	2,03	36,1	2,06	32,0	2,08	27,2	2,04	23,6	2,00
	70	-	-	-	-	35,7	1,90	31,7	1,92	27,2	1,89	23,5	1,83
	75	-	-	-	-	31,4	1,77	31,4	1,77	27,2	1,74	23,5	1,68
<b>7/6</b>	25	45,1	4,63	40,5	4,70	42,0	4,68	39,0	4,73	33,9	5,05	29,6	5,18
	35	50,3	3,82	50,4	3,83	44,7	3,98	38,3	4,02	32,9	4,16	28,7	4,25
	40	58,9	3,22	48,6	3,40	45,4	3,59	38,6	3,89	33,0	4,03	28,7	4,05
	45	55,0	3,20	48,9	3,21	43,7	3,32	37,7	3,35	32,0	3,40	27,9	3,43
	55	47,3	2,68	44,4	2,68	41,4	2,69	36,5	2,74	30,9	2,72	26,9	2,70
	60	45,3	2,39	43,1	2,43	40,9	2,47	36,0	2,50	30,5	2,47	26,6	2,44
	65	44,6	2,20	42,5	2,24	40,4	2,27	35,6	2,29	30,2	2,26	26,4	2,22
	70	-	-	-	-	39,8	2,09	35,3	2,11	30,1	2,08	26,1	2,02
	75	-	-	-	-	34,9	1,94	34,9	1,94	30,0	1,91	25,9	1,84

# Performances

## Heating - Size 18.1 - SC Version

Ta (°C) D.B./W.B.	Tw [°C]	Hot side exchanger outlet water temperature (°C)											
		100%		80%		70%		60%		50%		40%	
		Pheat	COP	Pheat	COP	Pheat	COP	Pheat	COP	Pheat	COP	Pheat	COP
10/9	25	65,9	4,46	55,4	4,79	49,4	5,02	43,2	5,17	36,8	5,40	32,2	5,54
	35	65,9	3,85	54,7	4,12	48,7	4,29	42,5	4,41	35,7	4,49	31,1	4,55
	40	62,5	3,38	52,5	3,65	47,1	3,80	41,8	4,15	35,8	4,34	31,1	4,38
	45	63,7	3,22	52,9	3,45	47,2	3,57	41,4	3,66	34,6	3,66	30,1	3,67
	55	49,4	2,77	47,0	2,82	44,6	2,87	39,4	2,94	33,4	2,93	28,9	2,89
	60	48,7	2,55	46,3	2,59	43,9	2,63	38,9	2,69	33,1	2,67	28,5	2,61
	65	47,9	2,35	45,6	2,38	43,2	2,42	38,3	2,45	32,7	2,44	28,2	2,37
	70	-	-	-	-	42,5	2,22	37,8	2,25	32,3	2,22	27,8	2,15
	75	-	-	-	-	37,2	2,05	37,2	2,05	31,9	2,02	27,5	1,95
18/12	25	70,7	4,72	58,8	5,04	52,8	5,31	47,6	5,64	41,9	6,03	36,9	6,20
	35	72,9	4,19	58,2	4,35	52,1	4,55	46,7	4,80	40,8	5,09	35,8	5,20
	40	69,6	3,70	56,3	3,88	50,4	4,05	45,4	4,27	39,9	4,82	35,7	4,99
	45	71,2	3,55	57,4	3,71	50,6	3,81	45,3	3,98	39,6	4,17	34,6	4,21
	55	55,4	3,07	51,6	3,07	47,8	3,07	43,2	3,21	37,8	3,31	33,2	3,31
	60	54,8	2,84	51,0	2,83	47,2	2,81	42,6	2,93	37,3	3,00	32,7	2,98
	65	53,9	2,61	50,6	2,61	47,3	2,62	42,0	2,67	36,8	2,72	32,3	2,70
	70	-	-	-	-	47,4	2,45	41,4	2,45	36,3	2,47	31,8	2,44
	75	-	-	-	-	41,6	2,28	41,6	2,28	35,7	2,25	32,1	2,25
42/31	25	-	-	-	-	75,1	6,66	67,0	6,99	58,7	7,56	51,7	7,86
	35	-	-	-	-	73,8	5,76	65,0	6,04	56,3	6,45	49,3	6,69
	40	-	-	-	-	71,3	5,01	63,3	5,60	55,4	6,39	49,1	6,68
	45	-	-	-	-	71,1	4,80	62,6	5,01	53,7	5,29	46,9	5,43
	55	-	-	-	-	-	-	-	-	-	-	-	-
	60	-	-	-	-	-	-	-	-	-	-	-	-
	65	-	-	-	-	-	-	-	-	-	-	-	-
	70	-	-	-	-	-	-	-	-	-	-	-	-
	75	-	-	-	-	-	-	-	-	-	-	-	-

To = Internal exchanger outlet water temperature (°C)

Tae [°C] = External exchanger inlet air temperature

Performance calculated with the inlet/outlet water temperature difference = 5°C\*

\*Always check the actual temperature difference on the configurator, as it is linked to the minimum or maximum flow-rate limits of the exchanger

### Integrated heating capacities

External exchanger inlet air temperature °C (D.B. / W.B.)	15/-16	-10/-11	-7/-8	2 / 1	Others
heating capacity multiplication coefficient	0,93	0,93	0,93	0,92	0,93

The integrated heating capacity is the actual heating capacity, including the impact of any defrosting cycles.

This is obtained by multiplying the thermal capacity supplied kWt (given in the heating performance tables) by the coefficients in the table.

During prolonged heat pump operating mode with negative ambient temperature, it is important to encourage the evacuation of water produced by the defrosting cycles to avoid the build-up of ice near the unit's base. Be careful to ensure that this does not constitute a danger to objects or people.

## Heating - Size 19.1 - SC Version

Ta (°C) D.B./W.B.	Tw [°C]	Hot side exchanger outlet water temperature (°C)											
		100%		80%		70%		60%		50%		40%	
		Pheat	COP	Pheat	COP	Pheat	COP	Pheat	COP	Pheat	COP	Pheat	COP
<b>-20/-21</b>	25	-	-	-	-	-	-	21,1	2,65	17,9	2,73	14,1	2,75
	35	-	-	-	-	-	-	21,1	2,26	18,1	2,29	14,6	2,29
	40	-	-	-	-	-	-	21,6	2,15	18,5	2,15	14,9	2,12
	45	-	-	-	-	-	-	21,3	1,93	18,5	1,94	15,1	1,92
	55	-	-	-	-	-	-	21,4	1,64	18,7	1,64	15,5	1,62
	60	-	-	-	-	-	-	-	-	-	-	-	-
	65	-	-	-	-	-	-	-	-	-	-	-	-
	70	-	-	-	-	-	-	-	-	-	-	-	-
	75	-	-	-	-	-	-	-	-	-	-	-	-
<b>-15/-16</b>	25	-	-	-	-	27,6	2,82	24,2	2,94	20,2	2,99	16,3	3,10
	35	-	-	-	-	27,5	2,41	24,2	2,48	20,6	2,54	16,4	2,54
	40	-	-	-	-	28,1	2,34	24,6	2,38	21,0	2,40	16,6	2,35
	45	-	-	-	-	27,4	2,06	24,2	2,11	20,9	2,14	16,8	2,12
	55	-	-	-	-	27,0	1,74	24,1	1,77	21,0	1,79	17,3	1,78
	60	-	-	-	-	27,1	1,63	24,2	1,64	21,2	1,66	17,5	1,64
	65	-	-	-	-	27,1	1,53	24,4	1,54	21,4	1,54	17,8	1,52
	70	-	-	-	-	-	-	-	-	-	-	-	-
	75	-	-	-	-	-	-	-	-	-	-	-	-
<b>-10/-11</b>	25	42,6	2,71	37,1	3,14	31,4	3,11	26,7	3,16	23,0	3,31	18,8	3,49
	35	42,8	2,40	36,7	2,69	31,1	2,63	27,3	2,72	22,9	2,76	18,8	2,87
	40	41,5	2,15	37,7	2,66	31,9	2,58	27,9	2,64	23,3	2,62	18,9	2,66
	45	42,2	2,07	36,4	2,31	30,9	2,25	27,4	2,31	23,3	2,35	18,8	2,36
	55	33,2	1,83	31,8	1,86	30,3	1,89	27,0	1,92	23,5	1,95	19,0	1,94
	60	33,1	1,72	31,7	1,74	30,3	1,76	27,1	1,78	23,6	1,80	19,3	1,79
	65	32,9	1,61	31,6	1,63	30,2	1,65	27,1	1,67	23,7	1,67	19,5	1,65
	70	-	-	-	-	30,2	1,55	27,1	1,56	23,8	1,56	19,7	1,52
	75	-	-	-	-	-	-	-	-	-	-	-	-
<b>-7/-8</b>	25	46,0	2,90	40,2	3,33	34,0	3,30	29,1	3,38	25,1	3,54	20,5	3,74
	35	46,4	2,56	39,9	2,87	33,7	2,79	29,6	2,90	24,9	2,95	20,3	3,07
	40	44,5	2,29	40,7	2,82	34,4	2,75	30,1	2,81	25,2	2,81	20,4	2,86
	45	45,6	2,20	39,4	2,46	33,3	2,37	29,3	2,44	24,6	2,46	20,2	2,52
	55	35,6	1,93	34,0	1,96	32,4	1,98	28,9	2,02	25,0	2,05	20,1	2,04
	60	35,4	1,80	33,9	1,82	32,3	1,85	28,9	1,88	25,1	1,89	20,3	1,87
	65	35,2	1,68	33,7	1,70	32,2	1,72	28,8	1,75	25,2	1,76	20,6	1,73
	70	-	-	-	-	32,1	1,61	28,8	1,63	25,2	1,64	20,8	1,60
	75	-	-	-	-	28,7	1,52	28,7	1,52	25,2	1,52	20,9	1,48
<b>2/1</b>	25	48,0	3,57	46,2	4,27	41,6	4,17	37,1	4,07	32,4	4,34	26,6	4,65
	35	48,1	3,33	51,7	3,58	42,7	3,41	36,6	3,44	31,6	3,60	25,9	3,81
	40	55,9	2,75	49,8	3,18	43,8	3,09	37,1	3,36	31,9	3,48	25,9	3,60
	45	57,3	2,63	50,4	3,02	42,3	2,89	36,5	2,92	30,9	2,98	25,3	3,09
	55	44,1	2,29	42,2	2,33	40,2	2,36	35,7	2,43	30,3	2,42	24,7	2,44
	60	43,6	2,11	41,7	2,15	39,8	2,18	35,4	2,24	30,3	2,24	24,5	2,21
	65	43,0	1,96	41,2	1,99	39,4	2,02	35,1	2,06	30,2	2,07	24,4	2,02
	70	-	-	-	-	39,0	1,87	34,7	1,91	30,2	1,92	24,3	1,85
	75	-	-	-	-	34,4	1,76	34,4	1,76	29,9	1,77	24,2	1,70
<b>7/6</b>	25	50,0	4,53	45,1	4,62	46,7	4,59	43,5	4,65	37,1	4,84	30,6	5,23
	35	55,8	3,80	55,0	3,74	49,5	3,87	43,1	3,99	36,2	4,06	29,6	4,29
	40	64,7	3,11	52,7	3,31	47,7	3,44	42,6	3,75	36,4	3,93	29,6	4,10
	45	59,7	3,05	53,3	3,14	48,1	3,24	42,3	3,34	35,3	3,36	28,7	3,47
	55	51,2	2,61	48,3	2,61	45,3	2,62	40,3	2,71	34,4	2,73	27,8	2,73
	60	49,0	2,33	46,8	2,37	44,7	2,41	39,8	2,48	34,0	2,50	27,5	2,47
	65	48,2	2,15	46,1	2,19	44,1	2,22	39,2	2,28	33,6	2,29	27,2	2,24
	70	-	-	-	-	43,4	2,05	38,7	2,10	33,5	2,11	26,9	2,04
	75	-	-	-	-	38,1	1,93	38,1	1,93	33,1	1,94	26,7	1,86

# Performances

## Heating - Size 19.1 - SC Version

Ta (°C) D.B./W.B.	Tw [°C]	Hot side exchanger outlet water temperature (°C)											
		100%		80%		70%		60%		50%		40%	
		Pheat	COP	Pheat	COP	Pheat	COP	Pheat	COP	Pheat	COP	Pheat	COP
10/9	25	71,6	4,29	60,3	4,67	54,2	4,86	48,1	5,07	40,6	5,21	33,2	5,60
	35	72,2	3,71	60,0	4,04	53,6	4,16	47,2	4,32	39,8	4,43	32,1	4,59
	40	67,9	3,24	57,7	3,59	51,6	3,69	45,7	3,84	39,9	4,26	32,1	4,43
	45	69,8	3,10	57,4	3,35	52,0	3,48	45,8	3,59	38,8	3,66	31,0	3,71
	55	53,2	2,68	51,0	2,74	48,7	2,80	43,3	2,89	37,3	2,95	29,8	2,93
	60	52,3	2,47	50,1	2,52	48,0	2,57	42,7	2,65	36,9	2,70	29,4	2,64
	65	52,3	2,31	49,7	2,33	47,2	2,36	42,0	2,43	36,4	2,46	29,1	2,39
	70	-	-	-	-	46,5	2,18	41,4	2,23	35,9	2,25	28,7	2,17
	75	-	-	-	-	40,7	2,04	40,7	2,04	35,3	2,05	28,4	1,97
18/12	25	78,4	4,62	62,6	4,82	56,8	5,05	51,6	5,39	45,5	5,78	38,0	6,27
	35	79,6	4,02	63,7	4,26	56,4	4,35	50,9	4,62	44,6	4,91	36,9	5,25
	40	75,0	3,51	62,0	3,82	54,3	3,86	49,2	4,11	43,5	4,61	36,9	5,04
	45	77,3	3,38	63,6	3,67	54,8	3,65	49,4	3,86	43,2	4,05	35,7	4,25
	55	59,8	2,98	55,9	2,97	52,1	2,97	46,7	3,10	41,2	3,25	34,2	3,35
	60	58,9	2,74	55,5	2,75	52,2	2,77	46,1	2,84	40,6	2,95	33,8	3,02
	65	57,9	2,52	55,1	2,56	52,3	2,59	45,8	2,62	40,0	2,69	33,3	2,72
	70	-	-	-	-	51,8	2,40	45,9	2,45	39,5	2,46	32,8	2,47
	75	-	-	-	-	45,8	2,27	45,8	2,27	39,3	2,26	33,1	2,28
42/31	25	-	-	-	-	81,5	6,42	73,2	6,74	63,8	7,16	53,4	7,95
	35	-	-	-	-	80,7	5,54	71,7	5,83	61,7	6,18	50,9	6,76
	40	-	-	-	-	76,7	4,68	68,9	5,17	60,7	6,04	50,7	6,75
	45	-	-	-	-	77,8	4,60	69,2	4,86	59,2	5,11	48,4	5,49
	55	-	-	-	-	-	-	-	-	-	-	-	-
	60	-	-	-	-	-	-	-	-	-	-	-	-
	65	-	-	-	-	-	-	-	-	-	-	-	-
	70	-	-	-	-	-	-	-	-	-	-	-	-
	75	-	-	-	-	-	-	-	-	-	-	-	-

To = Internal exchanger outlet water temperature (°C)

Tae [°C] = External exchanger inlet air temperature

Performance calculated with the inlet/outlet water temperature difference = 5°C\*

\*Always check the actual temperature difference on the configurator, as it is linked to the minimum or maximum flow-rate limits of the exchanger

### Integrated heating capacities

External exchanger inlet air temperature °C (D.B. / W.B.)	15/-16	-10/-11	-7/-8	2 / 1	Others
heating capacity multiplication coefficient	0,93	0,93	0,93	0,92	0,93

The integrated heating capacity is the actual heating capacity, including the impact of any defrosting cycles.

This is obtained by multiplying the thermal capacity supplied kWt (given in the heating performance tables) by the coefficients in the table.

During prolonged heat pump operating mode with negative ambient temperature, it is important to encourage the evacuation of water produced by the defrosting cycles to avoid the build-up of ice near the unit's base. Be careful to ensure that this does not constitute a danger to objects or people.

## Heating - Size 20.1 - SC Version

Ta (°C) D.B./W.B.	Tw [°C]	Hot side exchanger outlet water temperature (°C)											
		100%		80%		70%		60%		50%		40%	
		Pheat	COP	Pheat	COP	Pheat	COP	Pheat	COP	Pheat	COP	Pheat	COP
<b>-20/-21</b>	25	-	-	-	-	-	-	22,1	2,62	19,0	2,71	14,4	2,75
	35	-	-	-	-	-	-	22,1	2,24	19,2	2,29	14,9	2,29
	40	-	-	-	-	-	-	22,6	2,14	19,5	2,15	15,2	2,12
	45	-	-	-	-	-	-	22,2	1,92	19,4	1,94	15,4	1,92
	55	-	-	-	-	-	-	22,2	1,63	19,6	1,64	15,8	1,62
	60	-	-	-	-	-	-	-	-	-	-	-	-
	65	-	-	-	-	-	-	-	-	-	-	-	-
	70	-	-	-	-	-	-	-	-	-	-	-	-
	75	-	-	-	-	-	-	-	-	-	-	-	-
<b>-15/-16</b>	25	-	-	-	-	29,0	2,77	25,4	2,90	21,5	2,97	16,7	3,10
	35	-	-	-	-	28,9	2,37	25,3	2,46	21,9	2,53	16,8	2,54
	40	-	-	-	-	29,7	2,32	25,8	2,37	22,3	2,40	17,0	2,35
	45	-	-	-	-	28,8	2,04	25,3	2,10	22,1	2,14	17,1	2,12
	55	-	-	-	-	28,2	1,73	25,1	1,76	22,1	1,79	17,6	1,78
	60	-	-	-	-	28,2	1,62	25,2	1,64	21,9	1,64	17,9	1,64
	65	-	-	-	-	28,2	1,52	25,3	1,54	22,4	1,54	18,1	1,52
	70	-	-	-	-	-	-	-	-	-	-	-	-
	75	-	-	-	-	-	-	-	-	-	-	-	-
<b>-10/-11</b>	25	44,4	2,69	40,4	3,07	33,0	3,05	28,4	3,16	24,2	3,26	19,2	3,49
	35	44,8	2,39	40,3	2,67	32,7	2,59	28,7	2,70	24,3	2,74	19,1	2,87
	40	43,5	2,14	41,3	2,63	33,6	2,55	29,3	2,62	24,8	2,63	19,3	2,66
	45	44,2	2,07	39,9	2,30	32,5	2,21	28,6	2,29	24,8	2,34	19,2	2,36
	55	35,9	1,82	33,8	1,84	31,7	1,87	28,2	1,91	24,7	1,94	19,4	1,94
	60	35,7	1,70	33,7	1,72	31,7	1,75	28,2	1,78	24,8	1,79	19,7	1,79
	65	35,5	1,59	33,5	1,62	31,6	1,64	28,2	1,66	24,9	1,67	19,9	1,65
	70	-	-	-	-	31,5	1,54	28,2	1,56	24,9	1,56	20,1	1,52
	75	-	-	-	-	-	-	-	-	-	-	-	-
<b>-7/-8</b>	25	47,9	2,88	43,8	3,28	35,8	3,24	30,7	3,35	26,4	3,48	20,9	3,74
	35	48,5	2,55	43,7	2,85	35,5	2,76	31,0	2,86	26,4	2,93	20,7	3,07
	40	46,3	2,27	46,4	2,49	36,3	2,71	31,6	2,79	26,9	2,82	20,8	2,86
	45	47,6	2,19	43,1	2,44	35,1	2,35	30,7	2,41	26,2	2,45	20,6	2,52
	55	38,5	1,91	36,3	1,94	34,0	1,97	30,1	2,01	26,4	2,04	20,6	2,04
	60	38,2	1,78	36,0	1,80	33,8	1,83	30,1	1,87	26,4	1,89	20,7	1,87
	65	37,9	1,66	35,8	1,69	33,7	1,71	30,0	1,74	26,4	1,76	21,0	1,73
	70	-	-	-	-	33,5	1,60	29,9	1,63	26,4	1,64	21,2	1,60
	75	-	-	-	-	29,8	1,52	29,8	1,52	26,4	1,52	21,3	1,48
<b>2/1</b>	25	50,1	3,54	49,0	4,24	44,0	4,13	38,9	4,01	34,0	4,25	27,1	4,65
	35	52,5	3,29	56,5	3,54	45,5	3,40	38,6	3,43	33,2	3,53	26,4	3,81
	40	58,4	2,74	54,1	3,13	46,1	3,04	39,1	3,34	33,6	3,44	26,4	3,60
	45	59,7	2,61	55,0	2,98	44,5	2,86	38,5	2,92	32,6	2,93	25,8	3,09
	55	47,7	2,24	44,9	2,29	42,1	2,33	37,3	2,41	32,1	2,43	25,2	2,44
	60	47,1	2,07	44,4	2,11	41,7	2,15	36,9	2,22	32,1	2,25	25,0	2,21
	65	46,5	1,92	43,9	1,96	41,2	1,99	36,6	2,05	32,0	2,08	24,9	2,02
	70	-	-	-	-	40,7	1,85	36,2	1,90	31,7	1,92	24,8	1,85
	75	-	-	-	-	35,8	1,75	35,8	1,75	31,4	1,77	24,7	1,70
<b>7/6</b>	25	52,4	4,45	47,5	4,58	49,1	4,54	45,9	4,62	39,0	4,73	31,2	5,23
	35	61,0	3,75	59,2	3,64	52,0	3,82	45,5	3,97	38,3	4,02	30,2	4,29
	40	67,3	3,07	57,4	3,26	50,1	3,38	44,6	3,70	38,6	3,89	30,2	4,10
	45	66,4	2,85	58,3	3,10	50,6	3,20	44,3	3,31	37,7	3,35	29,3	3,47
	55	55,7	2,56	51,6	2,57	47,5	2,58	42,0	2,68	36,5	2,74	28,3	2,73
	60	53,3	2,29	50,0	2,33	46,8	2,38	41,5	2,46	36,0	2,50	28,0	2,47
	65	52,5	2,12	49,3	2,15	46,1	2,19	40,9	2,26	35,6	2,29	27,7	2,24
	70	-	-	-	-	45,4	2,02	40,3	2,09	35,3	2,11	27,5	2,04
	75	-	-	-	-	39,7	1,92	39,7	1,92	34,9	1,94	27,2	1,86

# Performances

## Heating - Size 20.1 - SC Version

Ta (°C) D.B./W.B.	Tw [°C]	Hot side exchanger outlet water temperature (°C)											
		100%		80%		70%		60%		50%		40%	
		Pheat	COP	Pheat	COP	Pheat	COP	Pheat	COP	Pheat	COP	Pheat	COP
10/9	25	74,2	4,25	64,7	4,56	56,8	4,77	50,1	4,99	43,2	5,17	33,9	5,60
	35	75,1	3,68	64,6	3,93	56,4	4,09	49,4	4,27	42,5	4,41	32,7	4,59
	40	70,4	3,19	61,4	3,45	54,1	3,62	47,7	3,79	41,8	4,15	32,8	4,43
	45	72,6	3,07	62,4	3,28	54,6	3,42	47,9	3,56	41,4	3,66	31,7	3,71
	55	57,4	2,61	54,3	2,68	51,1	2,75	45,2	2,86	39,4	2,94	30,5	2,93
	60	56,4	2,40	53,4	2,47	50,4	2,53	44,5	2,62	38,9	2,69	30,1	2,64
	65	55,3	2,21	52,5	2,27	49,7	2,34	43,8	2,41	38,3	2,45	29,7	2,39
	70	-	-	-	-	48,9	2,16	43,1	2,21	37,8	2,25	29,3	2,17
	75	-	-	-	-	42,3	2,03	42,3	2,03	37,2	2,05	29,0	1,97
18/12	25	80,9	4,56	69,0	4,81	58,9	4,91	53,4	5,28	47,6	5,64	38,8	6,27
	35	82,5	3,97	71,0	4,26	58,6	4,24	52,8	4,52	46,7	4,80	37,7	5,25
	40	77,5	3,45	68,5	3,79	56,5	3,76	51,0	4,02	45,4	4,27	37,6	5,04
	45	80,2	3,33	69,9	3,62	57,0	3,56	51,3	3,79	45,3	3,98	36,4	4,25
	55	64,3	2,88	59,6	2,91	55,0	2,94	48,4	3,05	43,2	3,21	34,9	3,35
	60	63,2	2,65	59,1	2,69	55,1	2,74	47,8	2,80	42,6	2,93	34,4	3,02
	65	62,1	2,44	58,4	2,49	54,8	2,55	48,0	2,62	42,0	2,67	34,0	2,72
	70	-	-	-	-	53,9	2,35	48,1	2,45	41,4	2,45	33,5	2,47
	75	-	-	-	-	47,5	2,25	47,5	2,25	41,6	2,28	33,8	2,28
42/31	25	-	-	-	-	84,9	6,30	76,1	6,62	67,0	6,99	54,4	7,95
	35	-	-	-	-	84,5	5,42	74,8	5,73	65,0	6,04	51,9	6,76
	40	-	-	-	-	79,9	4,56	71,6	5,06	63,3	5,60	51,7	6,75
	45	-	-	-	-	81,4	4,49	72,2	4,77	62,6	5,01	49,4	5,49
	55	-	-	-	-	-	-	-	-	-	-	-	-
	60	-	-	-	-	-	-	-	-	-	-	-	-
	65	-	-	-	-	-	-	-	-	-	-	-	-
	70	-	-	-	-	-	-	-	-	-	-	-	-
	75	-	-	-	-	-	-	-	-	-	-	-	-

To = Internal exchanger outlet water temperature (°C)

Tae [°C] = External exchanger inlet air temperature

Performance calculated with the inlet/outlet water temperature difference = 5°C\*

\*Always check the actual temperature difference on the configurator, as it is linked to the minimum or maximum flow-rate limits of the exchanger

### Integrated heating capacities

External exchanger inlet air temperature °C (D.B. / W.B.)	15/-16	-10/-11	-7/-8	2 / 1	Others
heating capacity multiplication coefficient	0,93	0,93	0,93	0,92	0,93

The integrated heating capacity is the actual heating capacity, including the impact of any defrosting cycles.

This is obtained by multiplying the thermal capacity supplied kWt (given in the heating performance tables) by the coefficients in the table.

During prolonged heat pump operating mode with negative ambient temperature, it is important to encourage the evacuation of water produced by the defrosting cycles to avoid the build-up of ice near the unit's base. Be careful to ensure that this does not constitute a danger to objects or people.

## Heating - Size 25.2 - SC Version

Ta (°C) D.B./W.B.	Tw [°C]	Hot side exchanger outlet water temperature (°C)											
		100%		80%		70%		60%		50%		40%	
		Pheat	COP	Pheat	COP	Pheat	COP	Pheat	COP	Pheat	COP	Pheat	COP
<b>-20/-21</b>	25	-	-	-	-	-	-	24,6	2,71	21,0	2,77	17,7	2,80
	35	-	-	-	-	-	-	24,3	2,28	21,0	2,32	17,8	2,31
	40	-	-	-	-	-	-	24,3	2,10	20,9	2,12	17,8	2,10
	45	-	-	-	-	-	-	24,5	1,95	21,0	1,94	17,9	1,91
	55	-	-	-	-	-	-	24,4	1,66	21,1	1,64	18,0	1,60
	60	-	-	-	-	-	-	-	-	-	-	-	-
	65	-	-	-	-	-	-	-	-	-	-	-	-
	70	-	-	-	-	-	-	-	-	-	-	-	-
	75	-	-	-	-	-	-	-	-	-	-	-	-
<b>-15/-16</b>	25	-	-	-	-	33,19	3,00	28,6	3,09	24,5	3,17	20,8	3,24
	35	-	-	-	-	32,56	2,53	28,1	2,59	24,1	2,63	20,5	2,65
	40	-	-	-	-	32,32	2,32	27,9	2,37	23,9	2,40	20,4	2,40
	45	-	-	-	-	32,10	2,14	27,8	2,17	23,9	2,19	20,4	2,19
	55	-	-	-	-	31,59	1,81	27,8	1,85	23,9	1,84	20,4	1,81
	60	-	-	-	-	31,46	1,67	27,7	1,70	23,9	1,69	20,4	1,66
	65	-	-	-	-	31,72	1,56	27,7	1,57	23,9	1,56	20,4	1,52
	70	-	-	-	-	-	-	-	-	-	-	-	-
	75	-	-	-	-	-	-	-	-	-	-	-	-
<b>-10/-11</b>	25	52,5	2,96	49,1	3,29	38,2	3,41	33,1	3,54	28,4	3,65	24,2	3,76
	35	51,2	2,51	47,8	2,78	37,3	2,86	32,3	2,95	27,7	3,02	23,6	3,08
	40	50,5	2,31	47,2	2,55	36,9	2,61	32,0	2,69	27,5	2,75	23,4	2,78
	45	49,9	2,13	46,7	2,36	36,6	2,39	31,7	2,46	27,2	2,49	23,2	2,51
	55	42,5	1,86	39,1	1,93	35,7	2,00	31,1	2,04	26,8	2,06	22,9	2,05
	60	42,1	1,72	38,8	1,78	35,5	1,84	30,9	1,88	26,8	1,90	22,9	1,88
	65	41,6	1,59	38,4	1,64	35,2	1,70	30,7	1,73	26,7	1,74	22,8	1,71
	70	-	-	-	-	34,9	1,57	30,8	1,60	26,7	1,60	22,8	1,56
	75	-	-	-	-	-	-	-	-	-	-	-	-
<b>-7/-8</b>	25	57,0	3,21	53,2	3,55	41,5	3,69	36,1	3,84	31,0	3,98	26,4	4,12
	35	55,2	2,68	51,7	2,98	40,4	3,08	35,1	3,19	30,1	3,28	25,6	3,36
	40	54,4	2,46	51,0	2,74	39,9	2,81	34,6	2,90	29,8	2,98	25,3	3,03
	45	53,7	2,27	50,3	2,52	39,5	2,57	34,3	2,65	29,4	2,70	25,0	2,73
	55	45,7	1,97	42,1	2,05	38,4	2,13	33,4	2,19	28,8	2,22	24,5	2,22
	60	45,1	1,82	41,6	1,89	38,0	1,96	33,1	2,00	28,6	2,02	24,4	2,01
	65	44,5	1,68	41,1	1,74	37,6	1,80	32,8	1,84	28,4	1,85	24,4	1,84
	70	-	-	-	-	37,3	1,66	32,6	1,69	28,4	1,70	24,3	1,67
	75	-	-	-	-	32,6	1,56	32,6	1,56	28,3	1,56	24,1	1,52
<b>2/1</b>	25	59,7	4,09	57,9	5,09	52,4	5,03	46,8	4,97	40,3	5,19	34,4	5,42
	35	62,1	3,52	66,8	3,78	51,9	3,91	45,0	4,10	38,7	4,27	32,9	4,43
	40	70,3	3,08	65,5	3,44	50,9	3,55	44,2	3,71	37,9	3,86	32,2	3,97
	45	68,8	2,81	64,2	3,14	50,0	3,23	43,3	3,36	37,2	3,47	31,6	3,55
	55	56,8	2,39	52,3	2,50	47,8	2,62	41,6	2,73	35,7	2,80	30,4	2,83
	60	55,7	2,18	51,3	2,28	46,9	2,38	40,9	2,47	35,1	2,52	29,9	2,53
	65	54,6	1,99	50,3	2,08	46,1	2,17	40,2	2,24	34,6	2,28	29,5	2,27
	70	-	-	-	-	45,2	1,97	39,5	2,03	34,1	2,06	29,1	2,05
	75	-	-	-	-	38,8	1,84	38,8	1,84	33,6	1,86	28,7	1,84
<b>7/6</b>	25	62,4	5,46	56,2	5,67	58,3	5,60	54,1	5,74	46,7	6,04	39,9	6,36
	35	70,2	3,93	70,3	3,94	59,8	4,50	51,8	4,74	44,5	4,98	38,0	5,20
	40	77,9	3,36	69,1	3,60	58,0	4,04	50,6	4,28	43,5	4,49	37,1	4,66
	45	78,5	3,16	67,6	3,28	56,8	3,67	49,6	3,88	42,5	4,03	36,2	4,15
	55	65,9	2,75	60,1	2,86	54,4	2,97	47,1	3,11	40,6	3,21	34,5	3,27
	60	62,5	2,44	57,8	2,56	53,1	2,69	46,1	2,80	39,7	2,88	33,8	2,91
	65	61,0	2,23	56,5	2,33	52,0	2,44	45,2	2,53	38,9	2,59	33,1	2,59
	70	-	-	-	-	50,9	2,22	44,2	2,28	38,1	2,32	32,4	2,31
	75	-	-	-	-	43,3	2,06	43,3	2,06	37,3	2,08	31,8	2,07

# Performances

## Heating - Size 25.2 - SC Version

Ta (°C) D.B./W.B.	Tw [°C]	Hot side exchanger outlet water temperature (°C)											
		100%		80%		70%		60%		50%		40%	
		Pheat	COP	Pheat	COP	Pheat	COP	Pheat	COP	Pheat	COP	Pheat	COP
10/9	25	90,2	4,89	80,2	5,16	67,3	5,87	59,2	6,28	50,9	6,62	43,6	7,00
	35	86,2	4,00	76,5	4,26	64,3	4,84	56,5	5,19	48,5	5,46	41,4	5,74
	40	84,2	3,63	74,7	3,86	62,8	4,37	55,2	4,69	47,3	4,92	40,3	5,14
	45	82,3	3,31	73,0	3,52	61,4	3,96	53,6	4,21	46,2	4,43	39,3	4,57
	55	68,9	2,88	63,5	3,03	58,1	3,18	51,0	3,38	43,8	3,50	37,3	3,57
	60	67,2	2,63	62,0	2,75	56,7	2,87	49,8	3,04	42,8	3,13	36,4	3,17
	65	65,6	2,40	60,5	2,50	55,4	2,60	48,7	2,73	41,8	2,80	35,6	2,81
	70	-	-	-	-	54,1	2,38	47,5	2,46	40,9	2,51	34,8	2,50
	75	-	-	-	-	46,5	2,23	46,5	2,23	39,9	2,23	34,0	2,22
18/12	25	103	5,53	92,5	5,89	77,6	6,69	68,5	7,25	59,9	7,85	52,1	8,49
	35	98,9	4,56	88,5	4,89	74,2	5,55	65,4	6,03	57,1	6,53	49,4	7,04
	40	96,7	4,15	86,5	4,46	72,5	5,03	63,9	5,47	55,7	5,89	48,1	6,31
	45	94,6	3,79	84,5	4,08	70,9	4,57	62,4	4,95	54,4	5,31	46,9	5,65
	55	79,9	3,36	73,6	3,54	67,3	3,71	59,1	3,94	51,5	4,18	44,2	4,36
	60	78,0	3,07	71,8	3,22	65,7	3,37	57,6	3,54	50,2	3,73	43,1	3,85
	65	76,0	2,81	70,1	2,94	64,2	3,07	56,4	3,21	49,0	3,33	42,0	3,41
	70	-	-	-	-	62,7	2,80	55,1	2,91	47,8	2,97	41,0	3,01
	75	-	-	-	-	53,8	2,64	53,8	2,64	46,7	2,67	40,0	2,65
42/31	25	-	-	-	-	109	9,02	95,9	9,87	83,6	10,84	72,4	12,0
	35	-	-	-	-	103	7,42	90,8	8,25	78,8	9,17	67,9	10,3
	40	-	-	-	-	100	6,67	88,3	7,46	76,4	8,29	65,7	9,25
	45	-	-	-	-	97,4	6,03	85,5	6,71	74,2	7,45	63,6	8,25
	55	-	-	-	-	-	-	-	-	-	-	-	-
	60	-	-	-	-	-	-	-	-	-	-	-	-
	65	-	-	-	-	-	-	-	-	-	-	-	-
	70	-	-	-	-	-	-	-	-	-	-	-	-
	75	-	-	-	-	-	-	-	-	-	-	-	-

To = Internal exchanger outlet water temperature (°C)

Tae [°C] = External exchanger inlet air temperature

Performance calculated with the inlet/outlet water temperature difference = 5°C\*

\*Always check the actual temperature difference on the configurator, as it is linked to the minimum or maximum flow-rate limits of the exchanger

### Integrated heating capacities

External exchanger inlet air temperature °C (D.B. / W.B.)	15/-16	-10/-11	-7/-8	2 / 1	Others
heating capacity multiplication coefficient	0,93	0,93	0,93	0,92	0,93

The integrated heating capacity is the actual heating capacity, including the impact of any defrosting cycles.

This is obtained by multiplying the thermal capacity supplied kWt (given in the heating performance tables) by the coefficients in the table.

During prolonged heat pump operating mode with negative ambient temperature, it is important to encourage the evacuation of water produced by the defrosting cycles to avoid the build-up of ice near the unit's base. Be careful to ensure that this does not constitute a danger to objects or people.

## Heating - Size 30.2 - SC Version

Ta (°C) D.B./W.B.	Tw [°C]	Hot side exchanger outlet water temperature (°C)											
		100%		80%		70%		60%		50%		40%	
		Pheat	COP	Pheat	COP	Pheat	COP	Pheat	COP	Pheat	COP	Pheat	COP
<b>-20/-21</b>	25	-	-	-	--	-	-	27,30	2,67	23,2	2,73	18,6	2,77
	35	-	-	-	--	-	-	26,95	2,26	23,0	2,29	18,6	2,28
	40	-	-	-	--	-	-	26,84	2,08	23,0	2,10	18,7	2,08
	45	-	-	-	--	-	-	26,77	1,92	23,2	1,95	18,8	1,90
	55	-	-	-	--	-	-	26,88	1,65	23,2	1,65	18,9	1,58
	60	-	-	-	--	-	-	-	-	-	--	-	-
	65	-	-	-	--	-	-	-	-	-	--	-	-
	70	-	-	-	--	-	-	-	-	-	--	-	-
	75	-	-	-	--	-	-	-	-	-	--	-	-
<b>-15/-16</b>	25	-	-	-	-	36,7	2,92	31,7	3,03	27,1	3,12	21,8	3,21
	35	-	-	-	-	36,0	2,47	31,1	2,55	26,6	2,61	21,5	2,63
	40	-	-	-	-	35,6	2,27	30,9	2,34	26,5	2,38	21,4	2,38
	45	-	-	-	-	35,4	2,10	30,7	2,15	26,3	2,18	21,4	2,17
	55	-	-	-	-	34,7	1,78	30,2	1,82	26,3	1,85	21,4	1,80
	60	-	-	-	-	34,5	1,65	30,1	1,68	26,3	1,70	21,5	1,64
	65	-	-	-	-	34,3	1,53	30,4	1,57	26,3	1,57	21,5	1,50
	70	-	-	-	-	-	-	-	-	-	-	-	-
	75	-	-	-	-	-	-	-	-	-	-	-	-
<b>-10/-11</b>	25	57,7	2,85	57,5	3,12	42,1	3,32	36,6	3,45	31,4	3,58	25,4	3,73
	35	56,2	2,41	56,1	2,64	41,1	2,78	35,7	2,89	30,6	2,97	24,7	3,05
	40	55,5	2,22	55,4	2,43	40,7	2,55	35,3	2,64	30,3	2,71	24,5	2,75
	45	54,9	2,06	54,7	2,24	40,2	2,34	35,0	2,42	30,0	2,47	24,3	2,49
	55	49,8	1,77	44,5	1,87	39,2	1,96	34,2	2,02	29,5	2,05	24,0	2,03
	60	49,4	1,65	44,1	1,73	38,9	1,81	34,0	1,86	29,3	1,88	24,0	1,86
	65	49,0	1,53	43,8	1,60	38,5	1,67	33,7	1,71	29,4	1,74	24,0	1,69
	70	-	-	-	-	38,2	1,54	33,9	1,59	29,3	1,60	23,9	1,54
	75	-	-	-	-	-	-	-	-	-	-	-	-
<b>-7/-8</b>	25	62,4	3,08	62,4	3,37	45,8	3,59	39,7	3,74	34,2	3,89	27,7	4,08
	35	60,7	2,59	60,6	2,83	44,5	2,99	38,7	3,11	33,2	3,22	26,9	3,33
	40	59,9	2,37	59,6	2,59	43,9	2,73	38,2	2,84	32,8	2,93	26,6	3,00
	45	58,9	2,18	58,8	2,38	43,4	2,50	37,8	2,59	32,5	2,67	26,3	2,71
	55	53,2	1,87	47,7	1,97	42,1	2,08	36,8	2,15	31,7	2,20	25,8	2,20
	60	52,5	1,72	47,1	1,82	41,6	1,91	36,4	1,98	31,4	2,01	25,6	1,99
	65	52,0	1,59	46,6	1,68	41,2	1,76	36,1	1,81	31,2	1,84	25,6	1,82
	70	-	-	-	-	40,7	1,62	35,7	1,67	31,2	1,70	25,5	1,66
	75	-	-	-	-	35,8	1,54	35,8	1,54	31,0	1,56	25,3	1,51
<b>2/1</b>	25	65,1	3,91	63,6	4,92	57,6	4,87	51,6	4,81	44,4	5,05	36,1	5,37
	35	73,9	3,35	79,4	3,60	56,9	3,77	49,6	3,98	42,7	4,16	34,5	4,39
	40	75,0	2,88	77,8	3,27	55,9	3,42	48,7	3,60	41,8	3,77	33,8	3,93
	45	75,5	2,68	76,3	2,98	54,9	3,12	47,8	3,28	41,1	3,40	33,2	3,52
	55	67,2	2,27	59,8	2,40	52,4	2,53	45,8	2,66	39,4	2,75	31,9	2,80
	60	65,8	2,08	58,6	2,19	51,4	2,31	44,9	2,41	38,7	2,49	31,4	2,51
	65	64,3	1,91	57,4	2,01	50,4	2,10	44,1	2,19	38,1	2,26	31,0	2,25
	70	-	-	-	-	49,5	1,92	43,4	2,00	37,5	2,05	30,5	2,03
	75	-	-	-	-	42,6	1,81	42,6	1,81	36,9	1,85	30,2	1,83
<b>7/6</b>	25	67,7	5,20	61,6	5,45	63,6	5,37	59,5	5,53	51,4	5,85	41,9	6,30
	35	84,2	3,77	81,8	3,66	64,9	4,27	57,0	4,56	49,1	4,83	39,9	5,15
	40	84,9	3,22	80,0	3,32	63,6	3,87	55,7	4,13	48,0	4,36	38,9	4,62
	45	85,8	3,03	78,4	3,03	62,2	3,51	54,5	3,74	47,0	3,94	38,0	4,12
	55	76,5	2,57	67,7	2,70	59,0	2,83	51,8	3,01	44,7	3,15	36,2	3,24
	60	72,9	2,29	65,3	2,43	57,7	2,57	50,7	2,72	43,8	2,84	35,4	2,88
	65	71,6	2,11	64,5	2,25	57,4	2,39	49,6	2,46	42,9	2,55	34,7	2,56
	70	-	-	-	-	56,1	2,18	48,6	2,23	42,0	2,30	34,0	2,29
	75	-	-	-	-	47,6	2,04	47,6	2,04	41,1	2,06	33,4	2,05

# Performances

## Heating - Size 30.2 - SC Version

Ta (°C) D.B./W.B.	Tw [°C]	Hot side exchanger outlet water temperature (°C)											
		100%		80%		70%		60%		50%		40%	
		Pheat	COP	Pheat	COP	Pheat	COP	Pheat	COP	Pheat	COP	Pheat	COP
10/9	25	98,1	4,70	92,6	4,83	73,7	5,61	64,6	5,99	56,0	6,39	45,8	6,93
	35	93,8	3,82	88,6	3,95	70,4	4,61	61,6	4,94	53,4	5,27	43,4	5,68
	40	91,8	3,46	86,5	3,58	68,8	4,17	60,2	4,47	52,1	4,76	42,3	5,09
	45	90,0	3,16	84,6	3,26	67,3	3,79	58,9	4,04	51,0	4,30	41,3	4,53
	55	80,0	2,68	71,8	2,87	63,6	3,05	55,7	3,24	48,3	3,42	39,1	3,54
	60	78,4	2,46	70,2	2,62	62,1	2,78	54,4	2,92	47,1	3,07	38,2	3,14
	65	76,7	2,26	68,7	2,40	60,7	2,53	53,1	2,64	46,0	2,76	37,3	2,79
	70	-	-	-	-	59,3	2,31	51,9	2,40	45,0	2,48	36,5	2,48
	75	-	-	-	-	51,4	2,22	51,4	2,22	44,0	2,23	35,7	2,20
18/12	25	111	5,26	105,7	5,45	84,1	6,30	74,7	6,87	65,4	7,46	54,7	8,41
	35	107	4,31	101,4	4,48	80,5	5,21	71,4	5,70	62,3	6,21	51,9	6,97
	40	105	3,91	99,1	4,08	78,8	4,74	69,8	5,17	60,9	5,62	50,5	6,26
	45	102	3,57	97,0	3,72	77,1	4,32	68,2	4,70	59,5	5,08	49,3	5,59
	55	91,6	3,07	82,4	3,31	73,2	3,55	64,6	3,78	56,3	4,03	46,4	4,32
	60	89,3	2,80	80,4	3,02	71,6	3,23	63,1	3,43	54,9	3,61	45,3	3,82
	65	87,0	2,57	78,4	2,76	69,9	2,95	61,7	3,12	53,6	3,24	44,1	3,37
	70	-	-	-	-	68,2	2,69	60,3	2,84	52,4	2,94	43,0	2,98
	75	-	-	-	-	58,8	2,58	58,8	2,58	51,2	2,66	42,0	2,62
42/31	25	-	-	-	-	118	8,45	104,4	9,27	91,3	10,20	76,0	11,88
	35	-	-	-	-	112	6,88	99,0	7,67	86,4	8,57	71,3	10,16
	40	-	-	-	-	109	6,19	96,3	6,92	83,9	7,75	69,0	9,16
	45	-	-	-	-	106	5,60	93,7	6,25	81,4	6,98	66,8	8,17
	55	-	-	-	-	-	-	-	-	-	-	-	-
	60	-	-	-	-	-	-	-	-	-	-	-	-
	65	-	-	-	-	-	-	-	-	-	-	-	-
	70	-	-	-	-	-	-	-	-	-	-	-	-
	75	-	-	-	-	-	-	-	-	-	-	-	-

To = Internal exchanger outlet water temperature (°C)

Tae [°C] = External exchanger inlet air temperature

Performance calculated with the inlet/outlet water temperature difference = 5°C\*

\*Always check the actual temperature difference on the configurator, as it is linked to the minimum or maximum flow-rate limits of the exchanger

### Integrated heating capacities

External exchanger inlet air temperature °C (D.B. / W.B.)	15/-16	-10/-11	-7/-8	2 / 1	Others
heating capacity multiplication coefficient	0,93	0,93	0,93	0,92	0,93

The integrated heating capacity is the actual heating capacity, including the impact of any defrosting cycles.

This is obtained by multiplying the thermal capacity supplied kWt (given in the heating performance tables) by the coefficients in the table.

During prolonged heat pump operating mode with negative ambient temperature, it is important to encourage the evacuation of water produced by the defrosting cycles to avoid the build-up of ice near the unit's base. Be careful to ensure that this does not constitute a danger to objects or people.

## User interface (HMI)

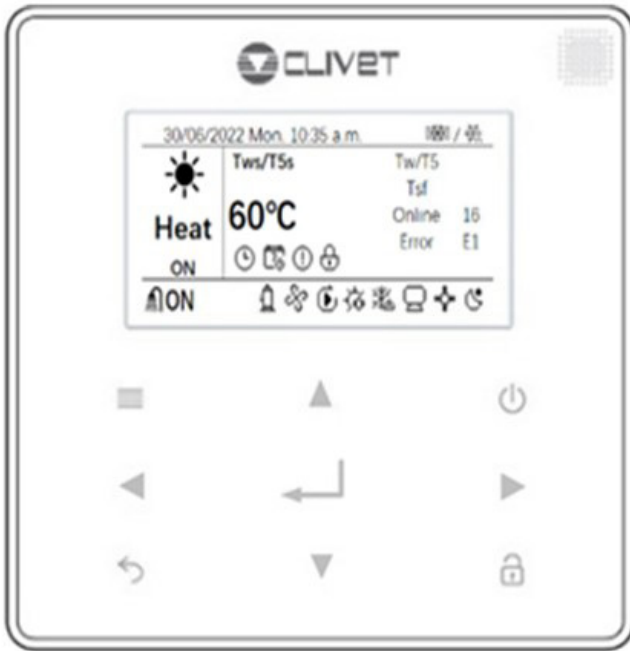

Resolution	1°C	
Temperature sensor	NTC 5k 1%	
Power input	< 1 W	
Storage temperature	-20÷50°C	
Communication	RS485	
Wiring	Type	Cavo schermato
	MAX Length	40 m

The unit is equipped with a user interface (HMI) installed on board, to be used for managing the functions and equipped with an integrated temperature probe.

The user interface comes standard with 22 selectable languages: Italian / English / French / Spanish / Polish / Portuguese / German / Dutch / Romanian / Russian / Turkish / Greek / Swedish / Slovenian / Czech / Slovakian / Bulgarian / Serbian / Danish / Ukrainian / Hungarian / Croatian



# Features and options

## DHW management

The following components are required for DHW management:

- SV1: 3-way valve
- Taf1: temperature probe, for DHW anti-freeze protection
- T5: temperature probe, for temperature control and switching between system and DHW

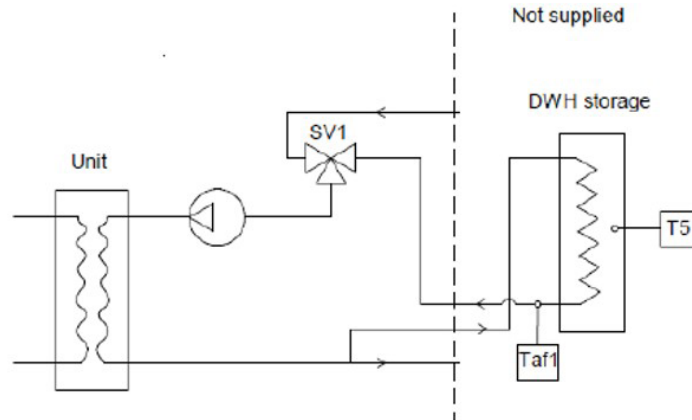

## Connection of a DHW boiler

As an option, the unit can be connected to a DHW tank of suitable volume, by fitting the system with a 3-way switching valve controlled by the unit. It is advisable to connect the DHW tank at a distance of no more than 10 m from the unit, and preferably as close as possible to it. The sizing of the connection piping and its thermal insulation must always be considered with care, especially in the case of long distances between the unit and the storage tank.

The standard boiler must have these characteristics:

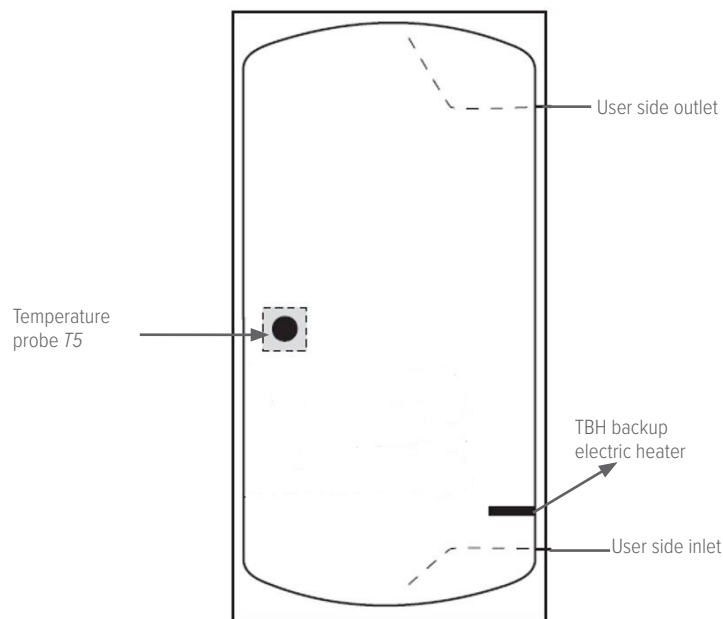

It is advisable to provide the boiler with a sacrificial anode and integrated backup electric heater, which will be controlled by the unit. Make sure that the coil or intermediate exchanger is properly sized to ensure correct heat exchange.

## Double Set-Point function

It allows to enable the Double setpoint function with HMI. Once enabled, you need to configure the first target water temperature (SetPoint1) and second target water temperature (SetPoint2). At this point the unit detects the closed status of the Double\_SP door (normally open). If the contact is open, the unit will operate at the first target water temperature; otherwise, it will operate at the second target temperature.

## Set-Point compensation function based on the outside air temperature

Allows to enable the temperature compensation function via HMI. Once the function has been enabled, it is necessary to set:

- The two offset points for the external air temperature (OffsetT4\_1; OffsetT4\_2), which will define the external air temperature field on which the set-point variation will take place;
- The offset point for the water production temperature (OffsetTws) which represents the maximum variation of the set-point allowed. Consequently the unit will update the proportional set-point according to the calculation cycle of the compensation function.

### Example of temperature compensation in heating mode

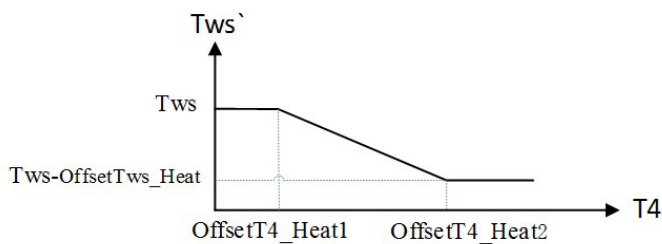

- When the external air temperature ( $T4$ ) is lower than the offset one ( $T4 < \text{OffsetT4\_Heat1}$ ) the set-point remains unchanged
- When the external air temperature ( $T4$ ) is between the two offset temperatures ( $\text{OffsetT4\_Heat1} \leq T4 < \text{OffsetT4\_Heat2}$ ), the set-point is reduced in direct proportion to the increase in external air temperature.
- When the outside air temperature ( $T4$ ) is higher than the highest offset temperature ( $T4 \geq \text{OffsetT4\_Heat2}$ ) there will be the maximum reduction in the set-point temperature.

## ENEMON function

Through the HMI it is possible to access the display of the main energy parameters of the displayed circuit and in detail

Power Output = instantaneous power produced in kW

Power Input = instantaneous power absorbed in kW

Current efficiency = instantaneous efficiency which is the EER or the COP

Total energy production is the cumulative energy produced in MWh

The total energy input is the cumulative energy input in MWh

STATE QUERY	
POWER OUTPUT	100 KW
POWER INPUT	50 KW
CURRENT EFFICIENCY	2
TOTAL ENERGY OUTPUT	10 MWh
TOTAL ENERGY INPUT	3 MWh
BACK	2/2 ▲▼ ◀▶

All energy meter display items are available via Modbus, on addresses from  $232+(\text{Circuit address}) \times 100$  a  $236+(\text{Circuit address}) \times 100$ .

# Features and options

## SILENT function

This mode enables the selection of up to three acoustic modes, for maximum sound configurability of the units.

For all modes, Standard, Silent and Super Silent, the thermal/cooling outputs, efficiencies and sound levels of all the sizes are given in the general technical data section of the bulletin.

To select the mode of interest, simply set it from the HMI through the User menu as shown in the following screen.

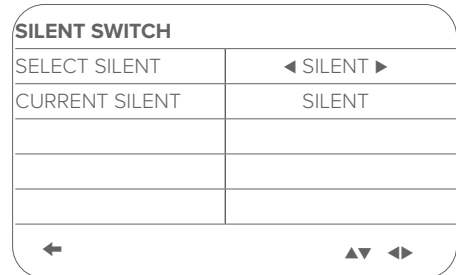

## Smart Grid & EVU functions (REMAU option required)

The unit is certified Smart Grid Ready and is equipped with logic for connection to devices that balance the loads connected to the electric grid and optimize general electricity consumption. The connection is optional, the function can be enabled from the REMAU and is linked to the ON/OFF SG input, which receives a status signal from the electrical network.

The unit is also set up to store free thermal energy in the DHW tank. The function is activated by the REMAU enabling the Smart Grid function and is linked to the ON/OFF EVU input, which receives a signal from the energy meter which indicates to the unit when free energy overproduction is available.

The regulation logic of the two contacts is:

CONTACT		OPERATION	
SG	EVU	SYSTEM	DHW
ON	ON	DHW forced	Forced DHW operation with set point T5S = 60°C Once the DHW set-point is reached, the Heat Pump returns to work on the system
OFF	ON	OFF forced	OFF forced
OFF	OFF	Standard	Standard
ON	OFF	Standard	Standard

## Modularity

Many applications require drives to be installed as back-up to the main system or have loads that can change significantly during annual operation.

In this mode, up to 16 units can be connected and operated in parallel without any additional accessories.

From the user interface of the unit defined as Master, the other units are electrically connected in series through the dedicated terminals P, Q and E. Each connected module is identified by an address, from 0 to 15: the Master unit is identified as 0. Complete control of the system (including ancillary elements such as external pumping system and auxiliary heater) is handled by the Master unit.

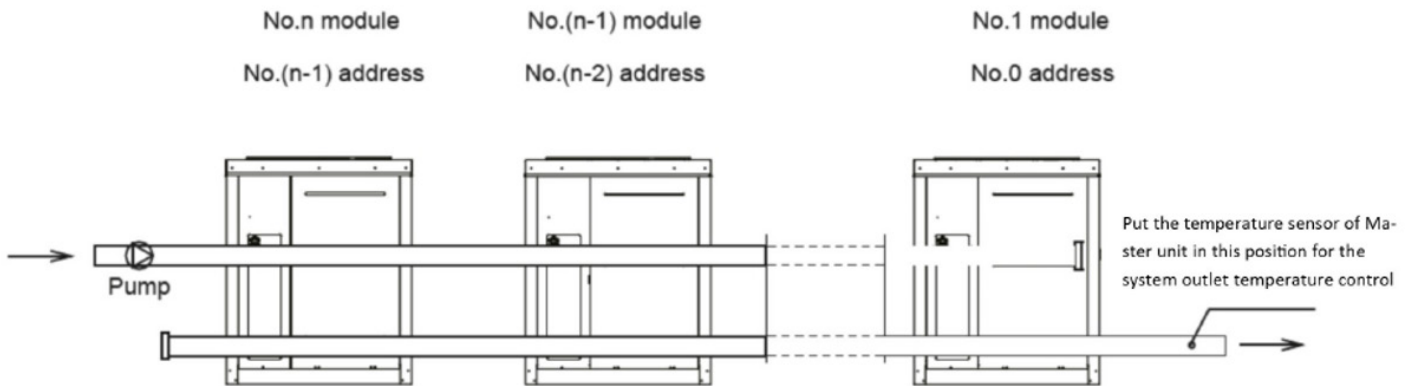

## Operation

The Master unit calculates the required heating/cooling capacity of the system based on the water delivery temperature and the temperature set-point. Instead, each individual unit calculates its required heating/cooling capacity based on the delivery and return temperatures. The activation of the units takes place according to the last in first out logic (the last unit to be activated will also be the first to be deactivated) and is indicated in the following two figures.

- $T_w$  = Water supply temperature
- $T_{ws}$  = Water supply temperature set-point

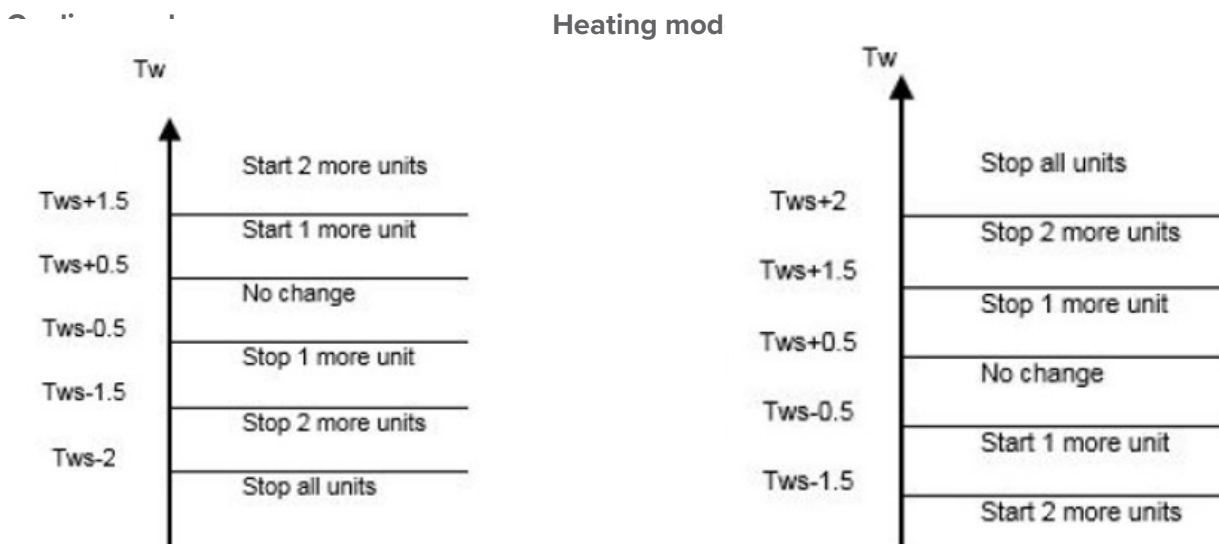

In cooling mode, if  $T_w \geq T_{ws} - 10^\circ\text{C}$  50% of the system units are activated.

In heating mode, if  $T_w \leq T_{ws} - 10^\circ\text{C}$  50% of the system units are activated.

After having satisfied the system load and having deactivated the units, at the next start-up the first unit to have been deactivated will be the first to be started, in order to guarantee the correct balancing of the operating hours.

# Modularity and management of cascade units

## DHW (Domestic Hot Water) settings and management

The unit is designed to be coupled to DHW storage boilers (HMI-enabled), connected with the T5 probe. To switch from system operation to DHW production, the system will first be stopped and then it will switch to DHW.

There are two conditions checked prior to DHW production start-up:

**CONDITION 1** that the T5 temperature measured by the DHW water tank is higher than the minimum value for DHW production start-up and lower than the minimum value between the DHW water tank set-point temperature and the maximum temperature that the unit can ensure at a given outdoor temperature, net of the temperature delta for DHW production start-up by default at 8°C.

**CONDITION 2** that the outlet temperature from the unit is lower than the minimum value between the DHW water tank set-point temperature and the maximum supply temperature that the unit can ensure at a given outdoor temperature, all reduced by default by 2°C.

DHW production is stopped if:

- The domestic hot water mode is stopped from the HMI
- The T5 temperature measured is higher than the minimum value between the DHW water tank set-point temperature and the maximum temperature that the unit can ensure at a given outdoor temperature
- The T5 temperature measured is lower than the minimum DHW production start-up value
- The Two outlet temperature from the unit is higher than the minimum value between the maximum supply temperature that the unit can ensure at a given outdoor temperature and the target set point of the unit increased by 2°C

### Installation with multiple pumps on the system

In a system with multiple pumps, both master and slave units must be configured separately for DHW operation, and therefore DHW production must be set as priority. The DHW priority is configurable on the following menu screen:

- **DHW production priority**  
Once the DHW priority is set, if the unit is in stand-by, CONDITION 1 is considered as in the case of a single pump system, and if this is verified, domestic hot water production is started, otherwise the unit is started to fulfil the load of the system.  
If CONDITION 1 is verified when the unit has exceeded the minimum system side operating period, then DHW production is started, otherwise activation of the TBH backup heater is considered and DHW production only switches to the heat pump after the minimum system side operating period and CONDITION 1 are fulfilled.
- **No DHW production priority**  
If no DHW priority has been set, the unit is started directly to fulfil the load of the system, and only after the minimum system side operating time has elapsed is CONDITION 1 considered. If this is fulfilled, DHW production is started, otherwise activation of the TBH backup heater is considered and DHW production only switches to the heat pump after CONDITION 1 is fulfilled.

DHW SWITCH	
SELECT ADDRESS	◀ 11 ▶
DHW SWITCH	◀ SI ▶
PRIORITY	◀ SI ▶
07 06 05 04 03 02 01 00	
15 14 13 12 11 10 09 08	
◀ ▶ ▲ ▼	

Caution: In DHW production mode, the compressors only start if the DHW tank temperature is above a minimum threshold (see table). To prevent the temperature from dropping below the minimum threshold, it is advisable to install an electric backup generator on the DHW storage tank.

T outdoor	T5	compr.	backup heater
24°C < t.o ≤ 30°C	< 15°C	OFF	ON
24°C < t.o ≤ 30°C	≥ 15°C	ON	OFF
t.o > 30°C	< 20°C	OFF	ON
t.o > 30°C	≥ 20°C	ON	OFF

The maximum settable value for T5S (DHW set-point) is 5°C lower than the maximum set-point achievable by the unit to account for the heat exchange through the DHW coil or the DHW heat exchanger installed and sized by the customer.

# Modularity and management of cascade units

Applications may require different management mode. Through the modular system it is possible to configure the system in different modes, here below one example:

- A. Configuration with independent operation: in this configuration it is necessary to have a DHW tank for each unit and a DHW three-way valve for each unit. The operation of each unit is independent from the others, each unit manages its own DHW production request.

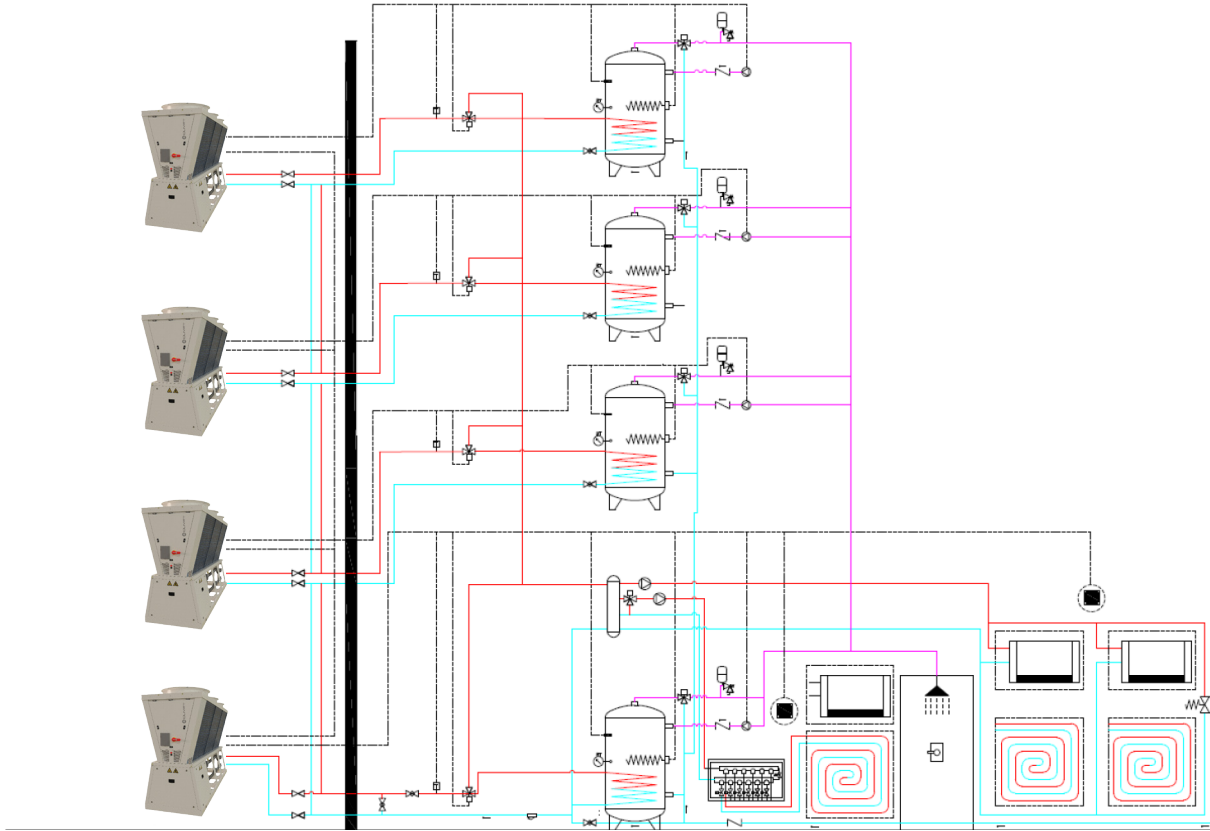

# Management of auxiliary heat sources

The optimal configuration solution of the auxiliary heat source involves the positioning of the electric heater in derivation on a DHW tank and the positioning of the boiler on the system.

The electric heater must be positioned into the DHW tank and its operation is linked to a dedicated T5 able to detect the DHW tank temperature

The boiler must be installed in parallel with the heat pump and acts on the system: it is installed on a hydraulic separator, where the TW probe must also be positioned

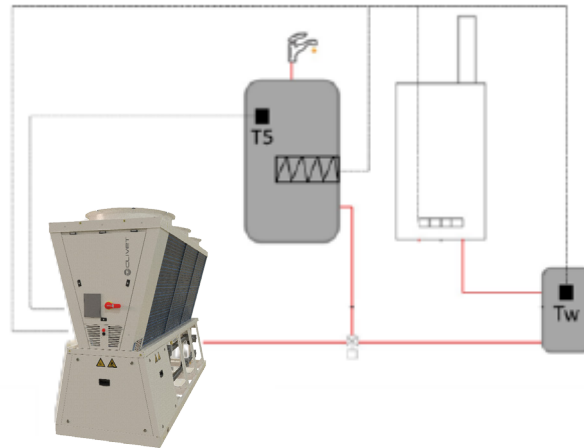

The setting must be completed during installation, by selecting the boiler operating mode using the unit keyboard.

The setting must be completed during installation, by selecting the boiler operating mode using the unit keyboard. The auxiliary heater source can perform the function of integration to the heat pump. To activate the functions of the heat pump integration heater, make sure that Dip-Switch S6-1 is in the ON position (upwards) and you must have activated Heat1 from the HMI; as regards the other parameters, they must be configured according to your needs once you understand their function which is described below. Within 2 minutes of switching on the pump, the auxiliary heater control is kept OFF and the following cases may arise:

- A. Operation of the auxiliary heater in place of the heat pump: When the heat pump cannot operate due to a fault or is in protection mode (compressors not limited): in this case the auxiliary heater intervenes in place of the heat pump when the water temperature is less than 3K compared to the set point and switches off once the water temperature has exceeded the set point by 2K (adjustable value from the HMI).
- B. Heat 1 activation forcing: In this mode, manual operation of the auxiliary heater will be started. Once the set point is reached the auxiliary heater will switch off. The manual command is valid only once therefore even if the water temperature drops below the setpoint it will not start automatically and will need a new manual command to start.
- C. Operation of the auxiliary heater at low air temperature: In case the unit is operating in heat pump mode with an air temperature lower than 5°C (Value adjustable from the HMI) but does not reach the set point within 90 min (value adjustable from the HMI), then the auxiliary heater integrates with the heat pump.
- D. Activation of the auxiliary heater in integration with the heat pump: If the set point is higher than the maximum set point of the unit envelope, then the auxiliary heater is activated in integration with the heat pump.

Title	Effect	Predetermined Area	Default
Heat1 Enable	Auxiliary plant heater	No/Yes	No
T_Heat1_Delay	Activation time	60.....240 min	90 min
DT_Heat1_OFF	$\Delta T$ off from set point	2.....10°C	5°C
T4_Heat1_ON	Air temperature below which Heat1 intervenes	-5..... 13°C	5°C

# Management of auxiliary heat sources

An additional HEAT2 contact is also available to control the additional electric heater for the DHW tank.

This function must also be enabled on the HMI and requires the installation of a T5 probe, according to which the additional DHW source is managed in various modes very similar to those described above. There is only one operation that differs substantially and that is the activation of the backup generator during the domestic hot water storage disinfection process, which takes place as follows:

Once the function is enabled on the HMI, it sends the disinfection cycle request:

If the unit is in stand-by/cooling or heating mode, it enters DHW mode and starts the disinfection cycle;

If the unit is running a defrosting process instead, the cycle is first completed and then the disinfection mode is enabled.

In this process, the permanence of the T5 temperature in the DHW tank above 69°C is considered. In fact, as soon as the T5 probe registers a value of 69°C or higher, an initial Timer1 count starts, which is stopped whenever the temperature drops below 69°C.

At the beginning of the disinfection cycle, however, a second Timer2 count starts.

Based on the two time parameters above, the disinfection cycle is completed if the DHW tank has maintained a temperature of 69°C or higher for at least twenty minutes, or if the disinfection cycle has lasted at least 60 minutes

# Dimensional drawings

SIZE 14.1 ÷ 20.1

DAASP0001\_00  
DATA/DATE 25/09/2023

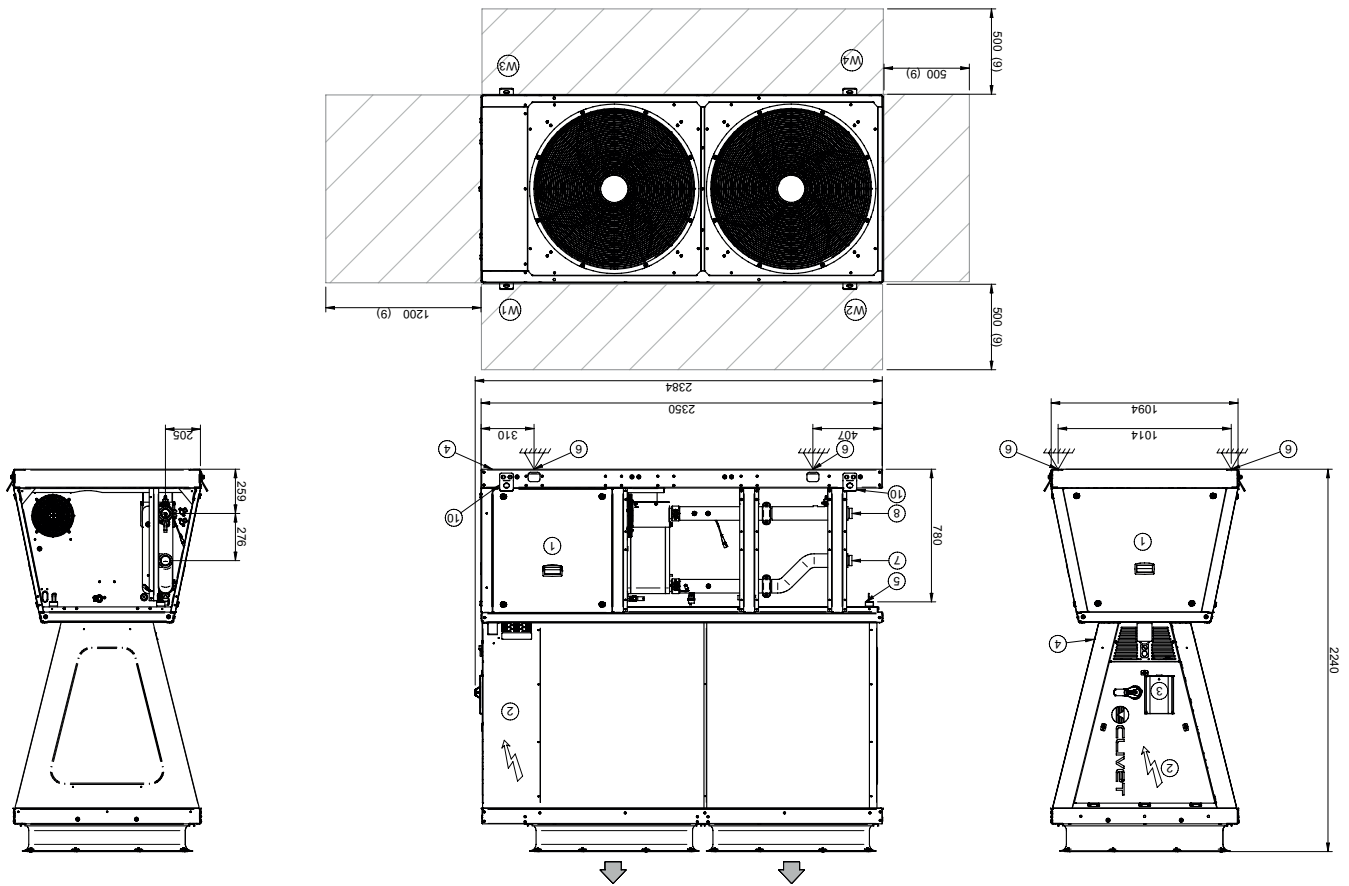

- 1. Compressor enclosure
- 2. Electrical panel
- 3. Control keypad
- 4. Power input
- 5. Condensate drain
- 6. Fixing point
- 7. Water inlet 2" victaulic
- 8. Water outlet 2" Victaulic
- 9. Functional spaces
- 10. Lifting bracket (Removable)

SIZE		14.1	16.1	18.1	19.1	20.1
Length	mm	2384	2384	2384	2384	2384
Depth	mm	1094	1094	1094	1094	1094
Height	mm	2240	2240	2240	2240	2240
W1 Support point	kg	218	218	234	234	234
W2 Support point	kg	135	135	142	142	142
W3 Support point	kg	222	222	238	238	238
W4 Support point	kg	139	139	146	146	146
Operation weight	kg	714	714	760	760	760
Shipping weight	kg	694	694	740	740	740

Optional accessories may result in a substantial variation of the weight shown in table

SIZE 25.2 ÷ 30.2

DAASP0002\_00  
DATA/DATE 25/09/2023

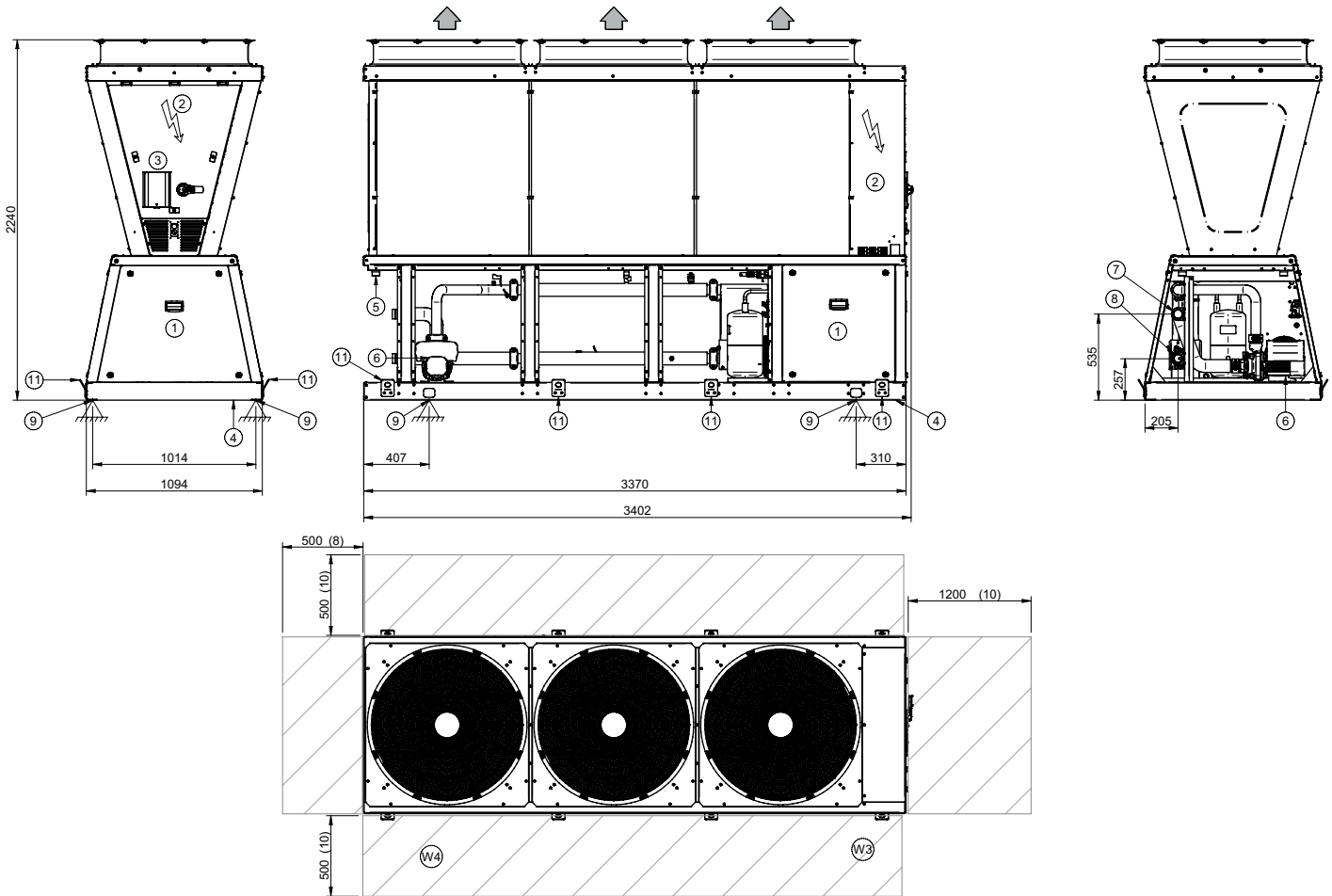

- |                          |                                 |
|--------------------------|---------------------------------|
| 1. Compressor enclosure  | 7. Water inlet 2" Victaulic     |
| 2. Electrical panel      | 8. Water outlet 2" Victaulic    |
| 3. Control Kaypad        | 9. Fixing point                 |
| 4. Power input           | 10. Functional spaces           |
| 5. Condensate drain      | 11. Lifting bracket (removable) |
| 6. Water pump (optional) |                                 |

SIZE		25.2	30.2
Length	mm	3402	3402
Depth	mm	1094	1094
Height	mm	2240	2240
W1 Support point	kg	306	306
W2 Support point	kg	199	199
W3 Support point	kg	312	312
W4 Support point	kg	205	205
Operation weight	kg	1021	1021
Shipping weight	kg	1001	1001

Optional accessories may result in a substantial variation of the weight shown in table

Page intentionally left blank

FOR 35 YEARS WE HAVE BEEN OFFERING SOLUTIONS TO ENSURE SUSTAINABLE COMFORT AND THE WELL-BEING OF PEOPLE AND THE ENVIRONMENT

[www.clivet.com](http://www.clivet.com)

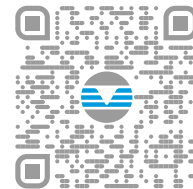

sale and assistance

Valid from: 2024 - (révision 03/2026)  
BT24D036GB-03



**CLIVET S.p.A.**

Via Camp Lonc 25, Z.I. Villapaiera 32032 - Feltre (BL) - Italy  
Tel. +39 0439 3131 - [info@clivet.it](mailto:info@clivet.it)

**CLIVET GMBH**

Hummelsbütteler Steindamm 84,  
22851 Norderstedt, Germany  
Tel. +49 40 325957-0 - [info.de@clivet.com](mailto:info.de@clivet.com)

**Clivet Group UK LTD**

Units F5 & F6 Railway Triangle,  
Portsmouth, Hampshire PO6 1TG  
Tel. +44 02392 381235 -  
[Enquiries@Clivetgroup.co.uk](mailto:Enquiries@Clivetgroup.co.uk)

**CLIVET LLC**

Office 508-511, Elektrozavodskaya st. 24,  
Moscow, Russian Federation, 107023  
Tel. +7495 6462009 - [info.ru@clivet.com](mailto:info.ru@clivet.com)

**CLIVET MIDEAST FZCO**

Dubai Silicon Oasis (DSO) Headquarter Building,  
Office EG-05, P.O Box-342009, Dubai, UAE  
Tel. +9714 3208499 - [info@clivet.ae](mailto:info@clivet.ae)

**Clivet South East Europe d.o.o.**

Jarušćica 9b  
10000, Zagreb, Croatia  
Tel. +3851 222 8784 - [info.see@clivet.com](mailto:info.see@clivet.com)

**CLIVET France SAS**

6 Allée Kepler,  
77420 Champs-sur-Marne  
France  
mail: [info.fr@clivet.com](mailto:info.fr@clivet.com)  
Tel: +33 01 88 60 99 40

**Clivet Airconditioning Systems Pvt Ltd**

Office No.501 & 502,5th Floor, Commercial -I,  
Kohinoor City, Old Premier Compound, Off LBS  
Marg, Kiroi Road, Kurla West, Mumbai  
Maharashtra 400070, India  
Tel. +91 22 30930200 - [sales.india@clivet.com](mailto:sales.india@clivet.com)