

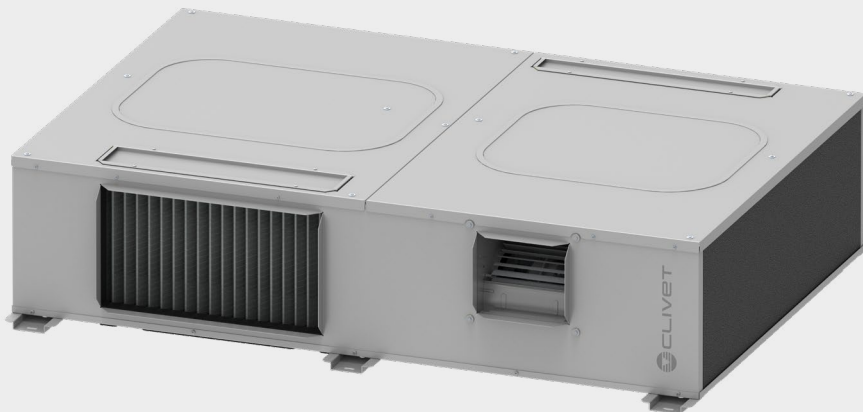

Fresh Large EVO

CiSDN-Y EF 1 S Size 1 - Size3



**Manual for installation, use
and maintenance**



16127160006983-C 04-2026

Valid from -2024 (revision C/2026)

Keep this manual with the wiring diagram in an accessible place for the operator.

Dear Customer,

Congratulations for choosing this product

Clivet has been working for years to offer systems able to assure the maximum comfort for a long time with highly-reliable, efficient, high-quality and safe solutions.

The target of the company is to offer advanced systems, that assure the best comfort and reduce energy consumption as well as the installation and maintenance costs for the entire life-cycle of the system.

With this manual, we want to give you information that is useful for all phases: from reception, installation and use to disposal - so that such an advanced system can provide the best performances during installation and use.

Best regards and have a good read.

CLIVET Spa

The original instructions are written in Italian.

All other languages are translations of the original instructions.

The data contained in this manual is not binding and may be changed by the manufacturer without prior notice. Reproduction, even partial, is FORBIDDEN.

© Clivet S.p.A. - Feltre (BL) - Italia.

Summary

1.	Safety considerations	6
1.1	Safety.....	6
1.2	Manual.....	6
1.3	Symbols.....	6
1.4	Risk situations.....	6
1.5	Intended use.....	6
1.6	Installation.....	6
1.7	Maintenance.....	6
1.8	Modifications.....	6
1.9	Fault or malfunction.....	6
1.10	User training.....	6
1.11	Data update.....	6
1.12	Translation of original instructions.....	7
1.13	General safety warnings.....	7
2.	Indications for the User	8
2.1	Fault or malfunction.....	8
2.2	The installer must train the user, particularly on:.....	8
2.3	Unit identification.....	8
2.4	Serial number.....	8
2.5	Assistance request.....	8
3.	Information on refrigerant gas	9
4.	Warnings for the installer and the Technical Support Service.....	10
4.1	General warnings.....	10
4.2	Safety checks and procedures.....	10
4.3	Main components.....	15
5.	Before installation	16
5.1	Reception.....	16
5.2	Storage.....	16
5.3	Handling.....	16
5.4	Removal of packaging.....	16
6.	Choosing the installation site	17
6.1	General.....	17
6.2	Functional spaces.....	17
6.3	Positioning.....	17
6.4	The unit is level.....	17
6.5	Unit fixing points.....	17
6.6	Floor installation.....	18
6.7	Ceiling installation.....	18
6.8	Access to the electrical panel.....	18
7.	Unit's remote keypad installation	19
7.1	Dimensions.....	20
7.2	Wall-mounted installation.....	20
8.	Water connections.....	22
8.1	Condensate drain.....	22
8.2	Pump head.....	22
8.3	Condensation drain connection.....	22
8.4	Risk of freezing.....	23

9.	Aeraulic connections	24
9.1	Treated air channelling.....	24
9.2	Size of connections.....	24
9.3	Aeraulic system.....	27
10.	Electrical connections.....	28
10.1	Electrical data	29
10.2	Remote controls.....	30
10.3	Connections to be provided by customer	30
11.	Start-up	33
11.1	Refrigeration circuit.....	33
11.2	Aeraulic circuit.....	33
11.3	Electric circuit.....	33
11.4	Voltages	33
11.5	Remote controls/signals	33
11.6	Start-up report	33
11.7	2014/68/UE PED directive.....	34
11.8	Start-up sequence	35
11.9	Start-up sequence	36
11.10	Airflow tables	37
12.	Control	38
12.1	Explanation of buttons	38
12.2	Explanation of symbols	39
12.3	Button Lock / Unlock	40
12.4	Switching on / off.....	40
12.5	temperature setting	40
12.6	Navigation menu.....	40
12.7	Operation mode.....	41
12.8	Timer	41
12.9	Daily timer.....	41
12.10	Weekly timer	42
12.11	Weekly schedule check.....	42
12.13	Deleting all TIMERS.....	42
12.14	Automatic temperature	43
12.15	Silent and Super Silent mode.....	43
12.16	Filter cleaning	44
12.17	Rescheduling filter cleaning with RECLOCK	44
12.18	Interface settings	45
12.19	Alarm display	45
12.20	Service information	45
12.21	Service information	46
12.22	Dehumidification settings.....	47
12.23	Dehumidification (from Modbus)	47
12.24	Compressor drive reset	47
12.25	Manual defrosting.....	47
12.26	Deleting alarms	48
12.27	Deleting settings.....	48
13.	Network configuration guidelines.....	49
13.1	Setting the keypad	49
13.2	Restore WLAN settings using the interface.....	50
14.	Mobile device setting.....	51

14.1	Open and sign up.....	51
14.2	Add device	51
14.3	Access to Wi-Fi network from mobile phone.....	52
14.4	APP functions	53
14.5	Silent and Super Silent mode.....	53
14.6	Scheduling.....	53
14.7	Scheduling.....	54
15.	Alarms	55
16.	Unit parameters.....	57
17.	Modbus communication	59
17.1	Control4 NGR.....	59
17.2	HMI connection.....	59
17.3	ModBus	60
18.	Maintenance.....	62
18.1	Safety	62
18.2	General.....	62
18.3	Frequency of interventions	62
18.4	Unit booklet.....	62
18.5	Standby mode	62
18.6	Structure.....	63
18.7	Recommended periodic checks sheet	64
18.8	Air filters	65
18.9	Electrostatic filter	66
18.10	Aeraulic system cleaning/sanitisation.....	68
19.	Decommissioning	69
19.1	Disconnection.....	69
19.2	WEEE INFORMATION	69
20.	Residual risks	70
20.1	General.....	70
20.2	Danger zone	70
20.3	Handling.....	70
20.4	Installation	70
20.5	General risks	70
20.6	Electric parts	70
20.7	Moving parts	71
20.8	Refrigerant.....	71
20.9	Hydraulic parts	71
21.	Technical information	72
22.	Dimensional	77

1. Safety considerations

1.1 Safety.

Operate in compliance with safety regulations in force.

To carry out the operations use protection devices:

- gloves, goggles, helmet, headphones, protective knee pads.

All operations must be carried out by personnel trained on possible risks of a general nature, electrical and deriving from operating with equipment under pressure.

Only qualified personnel can operate on the unit, as required by the regulation in force

1.2 Manual.

The manual provides correct unit installation, use and maintenance.

It is advisable to read it carefully so you will save time during operations.

Follow the written indications so you will not cause damages to things and injuries people.

The manual must be delivered to the User.

1.3 Symbols

The symbols in the following chapter can be found in the manual and on the product, and provide quick and clear information for correct and safe use.

1.3.1 Safety symbols

Danger

This symbol indicates warnings, failure to comply may result in serious harm to health and fatal injuries.

Warning

This symbol indicates warnings, failure to comply may result in irreparable damage to the product or harm to the environment.

Prohibition

This symbol indicates operations that must never be carried out.

Note

This symbol indicates important information.

1.4 Risk situations

The unit has been designed and created to prevent injuries to people.

During designing it is not possible to plane and operate on all risk situation.

Read carefully “Residual risk” section where all situation which may cause damages to things and injuries to people are reported.

Installation, starting, maintenance and repair required specific knowledge; if they are carried out by inexperienced personnel, they may cause damages to things and injuries people.

1.5 Intended use.

The unit is intended for air handling.

Within the limits defined in the technical bulletin and in this manual.

The manufacturer accepts no responsibility if the equipment is used for any purpose other than the intended use.

Do not treat air containing:

- high concentrations of dust
- aggressive substances
- industrial processing residues.

1.6 Installation.

► Indoor installation

► In a fixed position

The positioning, hydraulic system, refrigerating, electrics and the ducting of the air must be determined by the system designer in accordance with local regulations in force.

Follow local safety regulations.

Verify that the electrical line characteristics are in compliance with data quotes on the unit serial number label.

1.7 Maintenance.

Plan periodic inspection and maintenance in order to avoid or reduce repairing costs.

Turn the unit off before any operation.

1.8 Modifications.

All unit modifications will end the warranty coverage and the manufacturer responsibility.

1.9 Fault or malfunction.

Disable the unit immediately in case of breakdown or malfunction.

Contact a certified service agent.

1.10 User training.

The installer has to train the user on:

- Start-up/shutdown
- Set points change
- Standby mode
- Maintenance
- What to do/what not to do in case of failure.

1.11 Data update.

Continuous product improvements may imply manual data changes.











Visit manufacturer web site for updated data.

1.12 Translation of original instructions







The original instructions are written in Italian.

All other languages are translations of the original instructions.

1.13 General safety warnings

-  Read the “Safety considerations” chapter carefully before proceeding with any operation.
-  For every operation, always comply with current national regulations.
-  All personnel must be aware of the operations and of the hazardous situations that may arise when starting any operations on the unit.
-  Any contractual and non-contractual liability for damage caused to persons, animals or property by installation, adjustment or maintenance errors or improper use is excluded.
-  Any uses not expressly indicated in this manual are not permitted.
-  Do not change or tamper with the device as this can lead to hazardous situations.
-  Use appropriate safety clothing and equipment.
-  The manufacturer accepts no liability for failure to comply with current safety and accident prevention regulations.
-  The manufacturer reserves the right to make changes to its models at any time to improve its product, subject to the essential characteristics described in this manual.
-  The manufacturer is not obliged to add these changes to units previously manufactured, already delivered or being built.
-  The unit is suitable for use by children

aged 8 years and over and by persons with reduced physical, sensory or mental capabilities or lack of experience or knowledge if they are properly supervised or have received instructions on the safe use of the device and have understood the associated hazardous situations. Children must not play with the device. Cleaning and maintenance operations must not be carried out by children without supervision.

-  It is forbidden to touch the device with wet or damp parts of the body.
-  It is forbidden to carry out any operation before disconnecting the device from the mains power supply by turning the system’s main switch to “off”.
-  It is forbidden to change the safety or control devices without the device manufacturer’s authorisation and instructions.
-  It is forbidden to pull, unplug or twist the electrical cables coming out of the device, even if it is disconnected from the mains power supply.
-  It is forbidden to introduce objects and substances through the air intake and supply grills.
-  It is forbidden to open the access doors to internal parts of the unit without first turning the system’s main switch to “off”.

2. Indications for the User

Keep this manual with the wiring diagram in an accessible place for the operator.

Note the unit data label so you can provide them to the assistance centre in case of intervention (see “Unit identification” section).

Provide a unit notebook that allows any interventions carried out on the unit to be noted and tracked making it easier to suitably note the various interventions and aids the search for any breakdowns.

2.1 Fault or malfunction.

Disable the unit immediately in case of breakdown or malfunction.

Contact a certified service agent.

Use original spares parts only.

Using the unit in case of breakdown or malfunction:

- voids the warranty
- it may compromise the safety of the unit
- it may increase time and repair costs

2.2 The installer must train the user, particularly on:

- Start-up/shutdown
- Set points change
- Standby mode
- Maintenance
- What to do / what not to do in case of breakdown

2.3 Unit identification

The serial number label is positioned on the unit and allows to identify all the unit features.

The matriculation plate shows the indications foreseen by the standards, in particular:

- unit type
- serial number (12 characters)
- year of manufacture
- wiring diagram number
- electrical data
- type of refrigerant
- refrigerant charge
- manufacturer logo and address

The matriculation plate must never be removed.

2.4 Serial number

It identifies uniquely each unit.

Must be quoted when ordering spare parts.

2.5 Assistance request

Note data from the serial number label and write them in the chart on side, so you will find them easily when needed.

Series
Size
Serial number
Year of production
Wiring diagram number

3. Information on refrigerant gas

This section contains specific safety information and warnings on the use of R-32 refrigerant.

 For more comprehensive information, read the safety data sheet for the refrigerant used.



 The refrigerant used inside this unit is flammable. A refrigerant leak that is exposed to an external ignition source can create fire risks.

The refrigerant quantity is indicated on the unit plate

Size	Refrigerant (kg)	Equivalent CO ₂ tons
Size 1	0.6	0.40
Size 2	0.8	0.53
Size 3	1.7	1.13

Physical characteristics of the R32 refrigerant		
Safety class (ISO 817)	A2L	
GWP	675	
LFL Low flammability limit	0.307	kg/m ³ @ 60°C
BV Burning velocity	6,7	cm/s
Boiling point	-52	°C
GWP-AR5	675	100 yr ITH
GWP-AR5	677	ARS 100 yr ITH
Self-ignition temperature	648	°C

The values are below the maximum critical value specified in EN 60335-2-40 m1 (1.84Kg).

-  If the total refrigerant charge in the system is ≤1.84 kg, there are no minimum surface requirements.
-  According to this standard, there are no minimum space requirements for installation

4. Warnings for the installer and the Technical Support Service

 The use of flammable refrigerants entails specific safety warnings for certain operations during installation and maintenance.

4.1 General warnings

 The refrigerant used inside this unit is highly flammable. A refrigerant leak that is exposed to an external ignition source can create fire risks.

 Before starting work on systems containing flammable refrigerants, safety checks must be carried out to ensure that the risk of combustion is minimised.

 Installation and maintenance personnel and other people working in the area should be informed about the nature of the work to be done.

 Do not pierce or burn.

 The unit must be protected from accidental impacts so as to prevent mechanical damage that would cause a refrigerant leak.

 Ensure that there are no continuously operating ignition sources (naked flames, gas appliances, electric stoves, lit cigarettes, etc.).

 Do not place flammable objects (spray cans) within 1 metre of the exhaust air.

4.2 Safety checks and procedures

Before starting an intervention, carry out appropriate safety checks to ensure that the risk of ignition is minimal.

Follow these precautions before starting an intervention:

4.2.1 Checks in the area

Perform the following checks:

- carry out safety checks to ensure that the risk of combustion is minimised
- avoid working in tight spaces
- mark the area around the work space
- ensure safe working conditions around the area and check that there is no flammable material.

4.2.2 Work procedures

- Interventions must be carried out according to a controlled procedure in order to minimise the risk of

flammable gases or vapours being present during the work.

4.2.3 Checking the presence of refrigerant

Perform the following checks:

- the area must be checked using an appropriate refrigerant detector before and during the intervention so that the technician is aware of potentially flammable atmospheres
- check that the leak detector is suitable for use with flammable refrigerants (it does not generate sparks and is adequately sealed or intrinsically safe)
- check that it is placed in a suitable space to promptly check for leaks linked to the maintenance activity carried out

 It is forbidden to use leak detectors with halogen lamps.

 Remember that R-32 refrigerant is heavier than air.

4.2.4 Presence of fire extinguishers

When performing hot operations on refrigeration equipment or associated components:

- keep a suitable extinguisher at hand
- keep a dry-powder or CO₂ extinguisher near the work area.

4.2.5 Absence of ignition sources

When operations to be carried out on a refrigeration system involve exposing piping containing or having contained a flammable refrigerant.

Perform the following checks:

- all possible ignition sources, including cigarette smoke, should be kept at a sufficient distance from the installation, fixing, disassembly and disposal site, as flammable refrigerant may escape into the surrounding space during these operations.
- before starting the intervention, the area around the unit must be inspected to check that it does not present ignition or flammability hazards.

 It is forbidden to use any ignition source that could generate a risk of fire or explosion.

 It is forbidden to smoke near the unit. “NO SMOKING” signs must be affixed.

 It is forbidden to use a mobile phone near the unit.

4.2.6 Area ventilation

Before working on the system or performing hot operations.

Perform the following checks:

- the area must either be open or adequately ventilated
- ventilation must be constant throughout the entire operation and be capable of safely dispersing all refrigerant released and preferably expelling it outside into the atmosphere.

4.2.7 Checks on the refrigeration system

Perform the following checks:

- if an electrical component is replaced, the new one must be suitable for the intended use and in accordance with the correct specifications
- follow the manufacturer's maintenance and service instructions in all circumstances
- when in doubt, consult the manufacturer's technical department
- the charge volume must be suitable for the room volume and the intended use in which the components containing the refrigerant are installed, see the electrical installation requirements in EN 378
- ventilation devices and openings must open properly and not be obstructed
- if an indirect refrigerant circuit is used, the presence of refrigerant in the secondary circuits must be checked
- equipment markings must remain visible and legible
- markings and indications that become illegible must be corrected
- pipes or other components of the refrigerant circuit must be installed in locations where exposure to potentially corrosive substances is unlikely for components containing the refrigerant, unless they are made of materials inherently resistant to corrosion or adequately protected against the risk of corrosion.

4.2.8 Checks on electrical devices

Remember that:

- the fixing and maintenance procedures for electrical components must include initial safety checks and component inspection procedures
- if a defect is found that may generate safety risks, the power supply to the circuit must be interrupted until the problem is satisfactorily resolved
- if the problem cannot be solved immediately, but it is necessary to keep the system in operation, an appropriate temporary solution must be adopted
- the situation should be communicated to the owner of the unit so that all persons concerned can be duly informed.

Carry out the following checks:

- check that the capacitors are discharged: this procedure must be performed safely to avoid the possibility of sparks
- check that there are no live components or wires exposed while charging, resetting or venting the system
- check for ground fault interruptions
- check that the unit is not powered and if necessary disconnect the power supply before proceeding with the next steps.

4.2.9 Fixing sealed components

Remember that:

- all electrical users must be disconnected from the equipment before removing the seal covers, etc.
- if it is absolutely necessary to have a power supply during the intervention, a permanent leak detection method must be set up at the most critical point to signal any potentially dangerous situations
- the use of silicone sealants may make some types of leak detection equipment less effective.

Ensure that:

- the casing must not be altered to such an extent that the required level of protection is compromised, including damage to cables, excessive number of connections, use of terminals that do not conform to the original specifications, damage to seals, incorrect assembly of glands, etc.
- the device must be installed safely.
- seals or sealing materials have not deteriorated to such an extent that they no longer ensure a perfect seal keeping flammable atmospheres from entering
- spare parts must comply with the manufacturer's specifications.

4.2.10 Fixing intrinsically safe components

Remember that:

- before applying capacitance or permanent inductance loads to the circuit, check that this operation does not result in the permissible voltage and current values for the equipment in use being exceeded
- intrinsically safe components are the only types of components that can be operated under voltage in the presence of a flammable atmosphere
- the test device must have the correct nominal characteristics
- only use parts specified by the manufacturer to replace components
- other components can cause ignition of the refrigerant released into the atmosphere.

4.2.11 Wiring

Check that:

- the wiring must not be exposed to wear, corrosion, excessive pressure, vibration, sharp edges or other adverse environmental influences.

 The check should also take into account the effects of ageing or continuous vibration from compressors, fans or other similar sources.

4.2.12 Detection of flammable refrigerants

 The use of potential ignition sources for the search or detection of refrigerant leaks is prohibited under any circumstances.

 The use of halogen torches or other naked flame detection systems is not permitted.

4.2.13 Leak detection methods

Remember that:

- electronic leak detectors can be used to detect flammable refrigerants, but their sensitivity may not be adequate or require recalibration
- detection equipment must be calibrated in a refrigerant-free area
- the detector is not a potential ignition source and is suitable for the refrigerant
- leak detection equipment must be configured at a percentage of the lower flammability limit (LFL) of the refrigerant and be calibrated for the refrigerant used with confirmation of the appropriate gas percentage (max. 25%)
- leak detection fluids are suitable for use with most refrigerants but the use of detergents containing chlorine should be avoided, as chlorine can react with the refrigerant and corrode copper piping.

If there is a refrigerant leak:

- remove or extinguish all naked flames

- if brazing is required, all of the refrigerant must be removed from the system, or isolated (by means of shut-off valves) in a part of the system away from the leak
- purge the system with oxygen-free nitrogen (OFN) both before and during brazing.

4.2.14 Removal and evacuation

Follow the procedure below:

- ▶ remove the refrigerant
- ▶ purge the circuit with inert gas
- ▶ evacuate
- ▶ purge again with inert gas
- ▶ open the circuit by cutting or brazing

Remember that:

- the refrigerant charge can be recovered in the appropriate cylinders
- the system must be purged with oxygen-free nitrogen to make the unit safe
- it may be necessary to repeat this procedure several times
- compressed air or oxygen must not be used for this operation
- purging can be performed by introducing oxygen-free nitrogen into the vacuum circuit in the system and continuing to fill until the operating pressure is reached, then venting into the atmosphere and recreating the vacuum
- this procedure must be repeated until the refrigerant is completely exhausted from the system.

When the last charge of OFN is added:

- the system must be vented to barometric pressure to allow the work to be performed

 This operation is absolutely essential if brazing operations are to be carried out on the piping.

- check that the vacuum pump outlet is not closed for any ignition source and that good ventilation is available.

4.2.15 Charging operations

Remember that:

- when using charging equipment, avoid contamination with different refrigerants
- cylinders must be kept upright
- before the refrigerant is charged into the system, ensure that it is properly earthed
- the system must be labelled after charging (if the label is not already present)
- extreme care must be taken to avoid overfilling or underfilling the system
- before recharging the system, the pressure must be tested using oxygen-free nitrogen

- after charging, but before start-up, the system should not leak
- an additional check for leaks must be carried out before leaving the site.

4.2.16 Decommissioning

Remember that:

- before performing this procedure, it is essential that the technician is fully familiar with the equipment and all of its components
- all refrigerants must be recovered following safe procedures
- an oil and refrigerant sample must be taken before proceeding
- before reusing the recovered refrigerant, it should be analysed
- before starting the procedure, it is essential to check that the power supply is available
- electrically isolate the system.

Before proceeding, check that:

- mechanical equipment for handling refrigerant cylinders is available, if necessary
- the necessary personal protective equipment is available and is used
- the recovery process is carried out under the constant supervision of a competent person
- the recovery equipment and cylinders comply with the regulations in force.

To recover:

- if possible, transfer the refrigerant to the unit using a “pump-down” procedure
- if it is not possible to create a vacuum, use a manifold that allows the refrigerant to be exhausted from various parts of the system
- place the cylinder on the scale
- start the recovery device and use it according to the manufacturer’s instructions
- do not fill the cylinders excessively. (Do not exceed 80% of the liquid volume)
- do not exceed the maximum working pressure of the cylinder, even temporarily
- after filling the cylinders correctly and completing the procedure, transfer the cylinders and equipment from the site as soon as possible and close all shut-off valves on the equipment.
- before charging the recovered refrigerant into another refrigeration system, it must be cleaned and checked.

4.2.17 Labelling

Remember that:

- the device must be labelled to indicate that it has been decommissioned and emptied of refrigerant
- the label must be dated and signed
- labels indicating the content of flammable refrigerant

must be affixed to the machine.

4.2.18 Recovery

When discharging refrigerant from a system for maintenance or decommissioning reasons.

Check that:

- the refrigerant is removed safely
- only cylinders suitable for refrigerant recovery are used
- the number of cylinders required to hold the entire system charge is available
- all cylinders to be used are designed for the refrigerant recovered and labelled for that refrigerant (special refrigerant recovery cylinders)
- the cylinders are equipped with a pressure relief valve and well-functioning shut-off valves
- empty recovery cylinders are evacuated and, if possible, cooled before recovery
- the recovery equipment is in good working order, accompanied by a set of instructions at hand, and suitable for the recovery of flammable refrigerants
- a set of well-functioning calibrated scales is provided
- the pipes are complete with decoupling fittings that are leak-free and in good condition
- the recovery equipment is in good working order, has been properly maintained and the associated electrical components are sealed to prevent a risk of ignition in the event of refrigerant leakage. If in doubt, consult the manufacturer.
- the refrigerant is returned to the supplier in the correct recovery cylinders, accompanied by the relevant waste identification form
- different types of refrigerant are not mixed in the recovery units, especially in the cylinders
- if compressors or compressor oils are decommissioned, evacuate them to an acceptable level to prevent flammable refrigerant from remaining inside the lubricant
- the evacuation procedure is carried out before returning the compressor to the suppliers
- only the electric heating on the compressor body is used to accelerate this process
- when oil is extracted from the system, it is drained using a safe procedure.

4.2.19 Transportation, marking, storage and disposal of units

- comply with current national regulations.

4.2.20 **Receipt and handling**

On receipt of the unit:

- check if there is refrigerant inside the packaging using an electronic leak detector suitable for the system refrigerant
- if there is, it is likely that the refrigerant circuit is damaged
- In this case, the unit must not be installed and the Technical Support Service must be called.

4.3 Main components

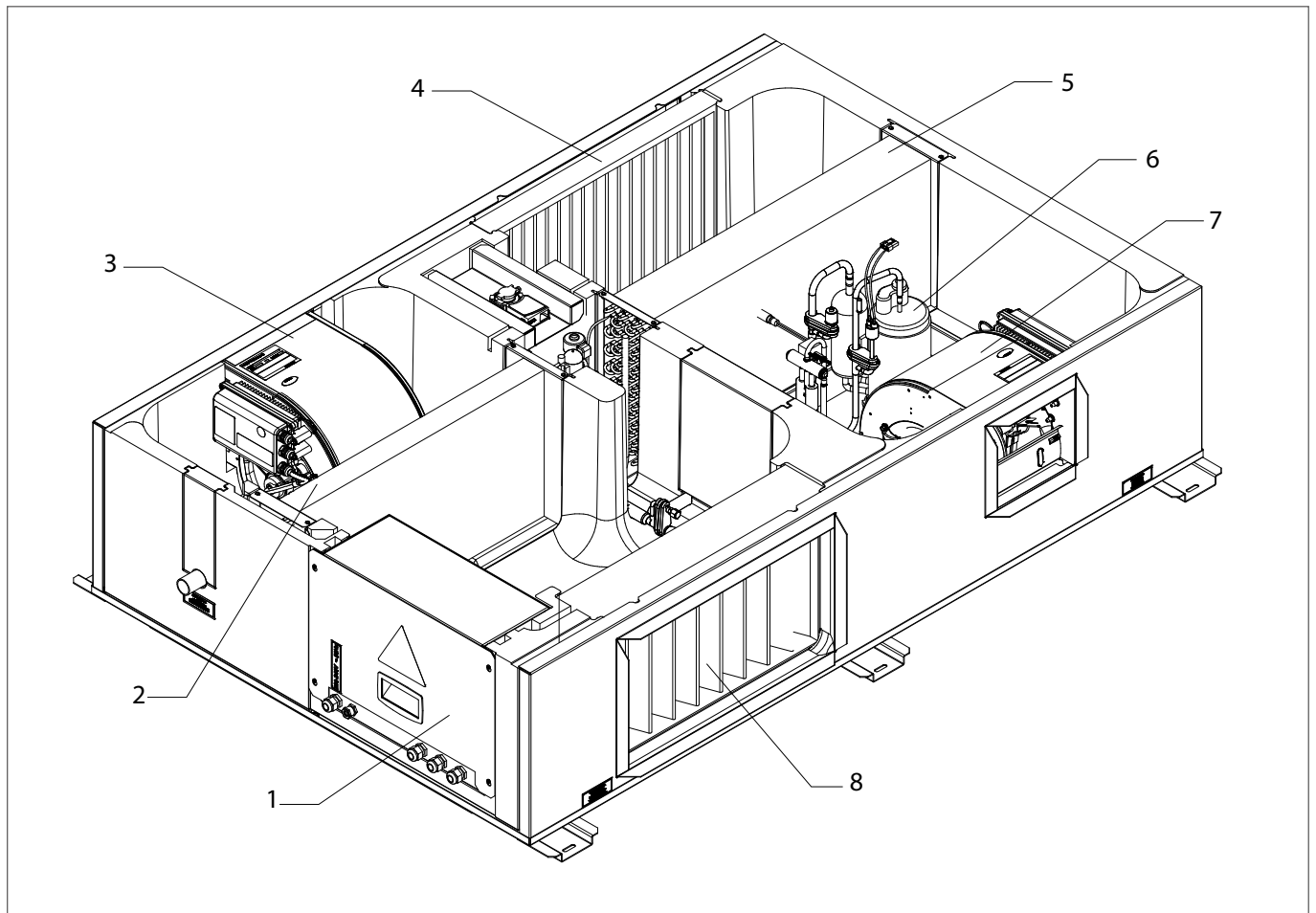

No.	Component
1	Electrical panel
2	Supply exchanger
3	Supply fan
4	Ambient return air filter
5	Exhaust exchanger
6	Compressor
7	Exhaust fan
8	Outdoor air filter

i The images are provided for illustrative purposes only.

5. Before installation

5.1 Reception

Before accepting the delivery, check:

- that the unit has not been damaged during transport
- that the materials delivered match those indicated on the transport document, comparing the data with the serial number label on the packaging.

In case of damage or anomaly:

- immediately write down the damage found on the transport document and quote this sentence: "Accepted with reservation due to evident shortages/damages during transport"
- refer to the contractual document.

- i** Any disputes must be made within 8 days from the date of the delivery. Complaints after this period are invalid .

5.2 Storage

Respect the indications on the outside of the pack.

In particular:

- minimum temperature -10°C (possible damage to components)
- maximum ambient temperature +50 °C (possible safety valve opening)
- maximum relative humidity 95% (possible damage to electrical components)

- !** Exceeding these limits can cause irreversible damage to the unit.

5.3 Handling

- !** Check that all handling equipment complies with local safety regulations (crane, forklifts, ropes, hooks, etc.).

- !** Provide personnel with personal protective equipment suitable for the situation, such as helmet, gloves, accident-prevention shoes, etc.

- !** Observe all safety procedures in order to guarantee the safety of the personnel present and the material.

- !** Verify unit weight and handling equipment lifting capacity.

- !** Do not leave packages loose during transport

- 1 Identify critical points during handling (interrupted routes, flights of stairs, steps, doors);
- 2 Protect the unit adequately to avoid damage;
- 3 Lift and keep it balanced;

Lifting with forks:

- insert the forks

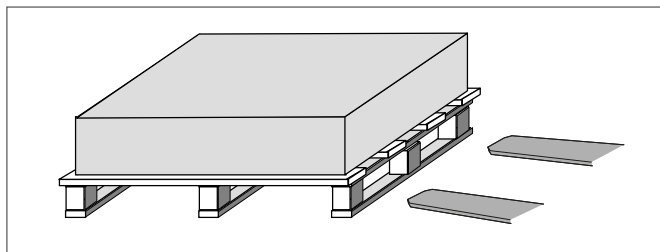

Before starting the handling, make sure that the unit is stable.

- !** It is forbidden to lift more than one package at a time while they are loose.

5.4 Removal of packaging

Be careful not to damage the unit.

Recycle and dispose of the packaging material in compliance with local regulations.

- !** Keep the packaging material out of children's reach as it may be dangerous.

6. Choosing the installation site

6.1 General

Installation must be in accordance with local regulations. If they do not exist, follow EN378 .

During positioning consider these elements:

- customer approval
- unit weight and bearing point capacity
- safe accessible position
- functional spaces
- ducting spaces
- electrical connections
- max. distance allowed by the electrical connections

6.2 Functional spaces

Functional spaces are designed to:

- guarantee good unit operation
- carry out maintenance operations
- protect authorized operators and exposed people
- consider the space required for filter extraction

⚠ Respect all functional spaces indicated in the TECHNICAL INFORMATION section.

6.3 Positioning

The unit is designed to be installed:

- indoors
- in fixed positions

⊘ The unit cannot be installed outdoors or in a room/compartment where the temperature can fall below 10°C.

Installation standards:

- avoid places that may be subject to flooding and humidity (e.g. laundries)
- the operating noise and exhaust air flow must not disturb neighbours
- verify unit weight and bearing point capacity
- verify that all bearing points are aligned and levelled
- install the unit raised from the ground
- bearing points aligned and leveled
- unit levelled
- provide the openings indicated in the functional spaces in the false ceiling to allow access to the unit for maintenance work
- positioning on the ceiling: leave the floor projection of the unit and functional spaces free to allow access with ladders or other means
- positioning on the floor: install the unit raised from the ground, on a frame (to be provided by the customer) to allow filter maintenance (extraction from below) if the filters cannot be removed from the top of the unit.

Limit vibration transmission:

- use anti-vibration devices or neoprene strips on the unit support points
- install flexible joints on the hydraulic connections

⚠ Neglecting these aspects can reduce the unit's performance and service life.

6.4 The unit is level

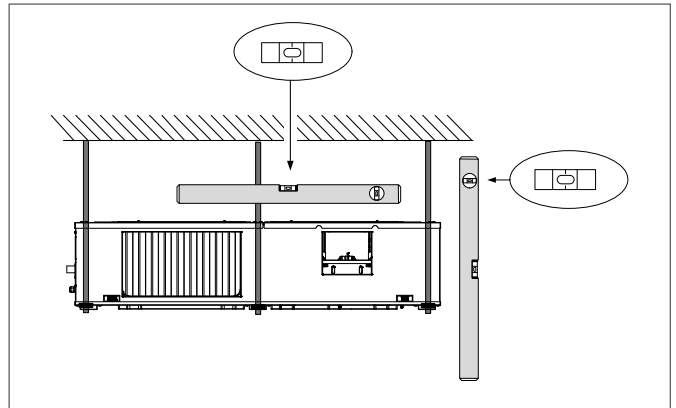

6.5 Unit fixing points

Sizes: SIZE 1 - SIZE 2 - SIZE 3

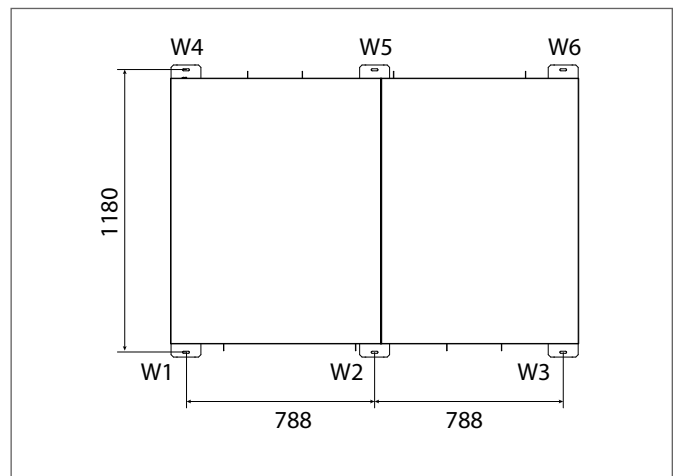

Weight distribution

Size		SIZE 1	SIZE 2	SIZE 3
W1 - W2 - W4 - W5	kg	15	20	22
W3 - W6	kg	18	23	25

⚠ Fix the unit using all 6 fixing points.

6.6 Floor installation

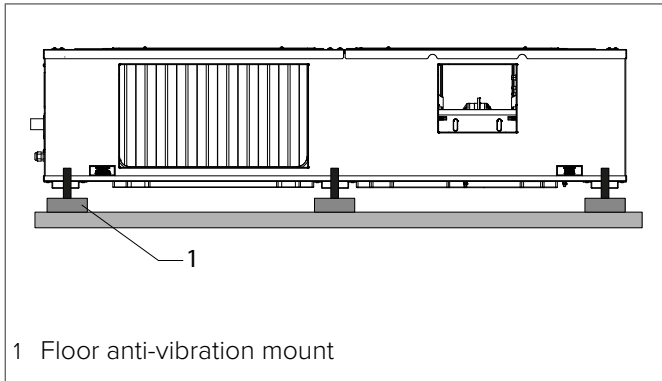

Floor anti-vibration mount

Accessory supplied separately.

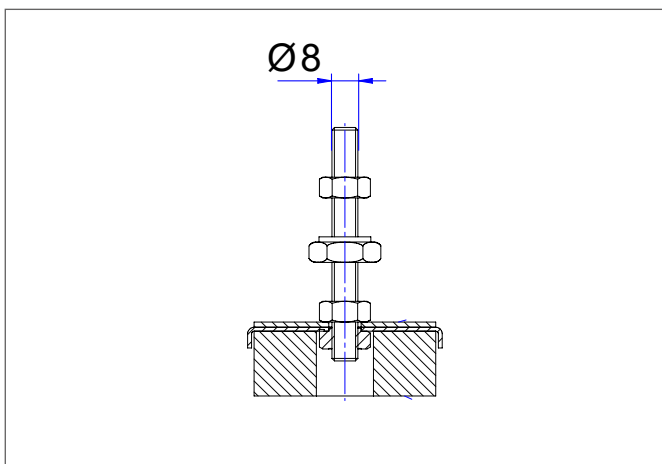

Ceiling anti-vibration mount

Accessory supplied separately.

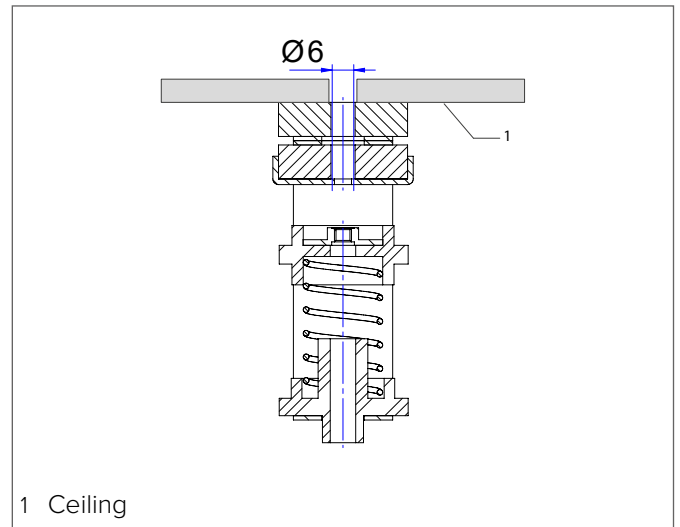

6.8 Access to the electrical panel

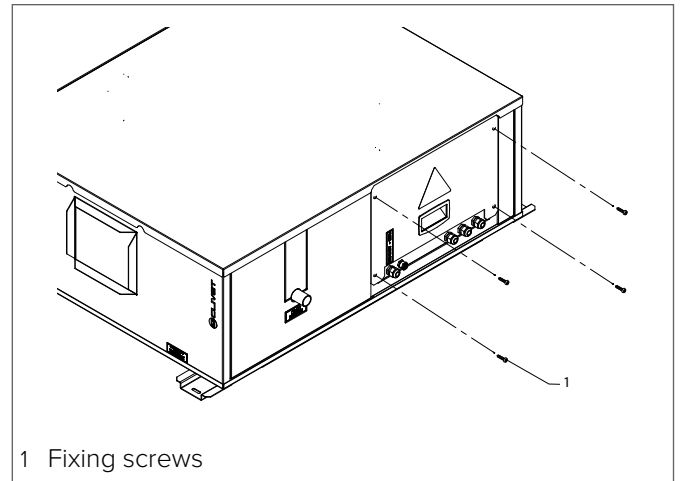

Remove the fixing screws.

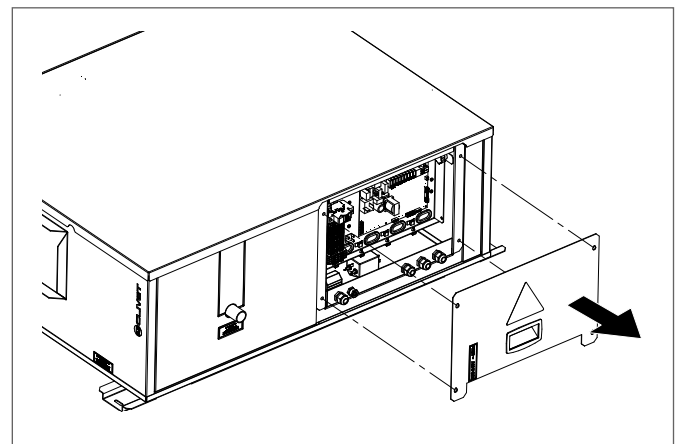

Remove the panel from the electrical panel.

6.7 Ceiling installation

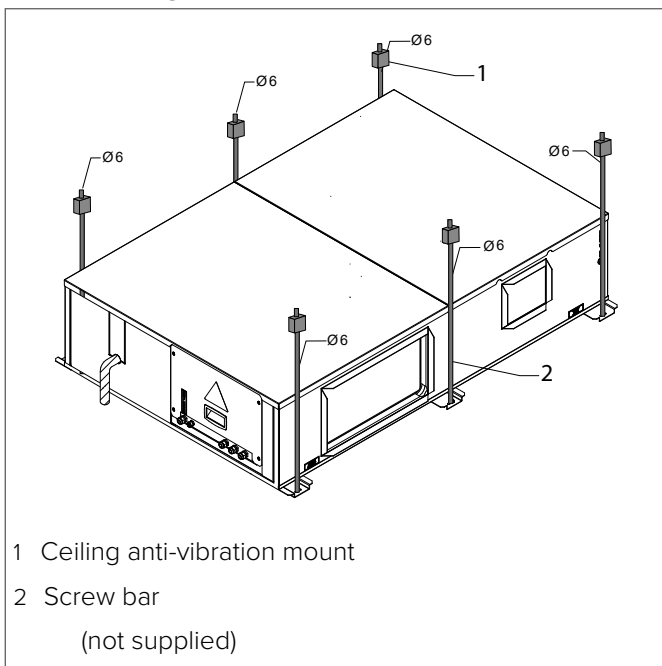

7. Unit's remote keypad installation

The unit is supplied with the HMI keypad.

Positions:

- ⊖ Near to heat sources.
- ⊖ In points exposed to direct solar radiation.
- ⊖ In a position exposed to air coming through openings or diffusers.
- ⊖ Behind curtains or furniture.
- ⊖ Next to doors and windows to the outside.
- ⊖ On walls crossed by chimneys or heating pipes.
- ⊖ On outdoor walls.
- ⊖ In environments with a strong presence of oil, steam or gaseous sulphides.
Failure to do so may result in damage to the controller and malfunction.
The wired remote controller circuit is low voltage.
- ⊖ Do not connect to a normal 220V/380V circuit, nor place it in the same wiring conduit as such a circuit.

Check that:

- the choice of installation point is crucial for environmental comfort and power consumption
- The thermostat must be fitted:
- in a room with average temperature and humidity conditions, representative of the other rooms
- 150 cm high
- preferably on an internal wall

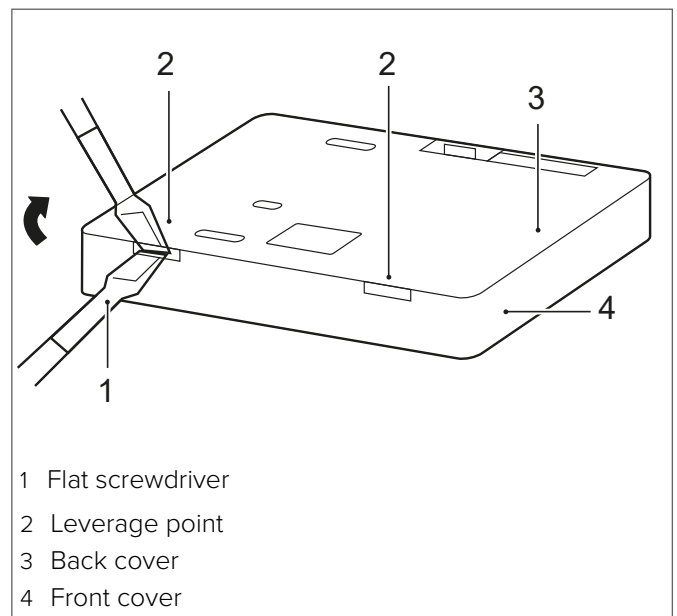
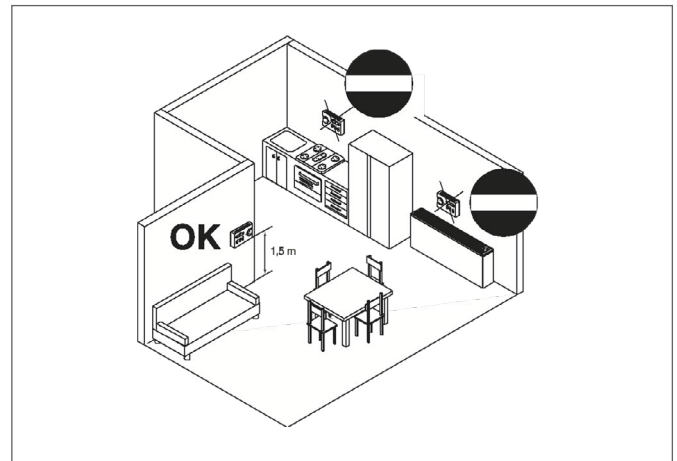

- 1 Flat screwdriver
- 2 Leverage point
- 3 Back cover
- 4 Front cover

7.1 Dimensions

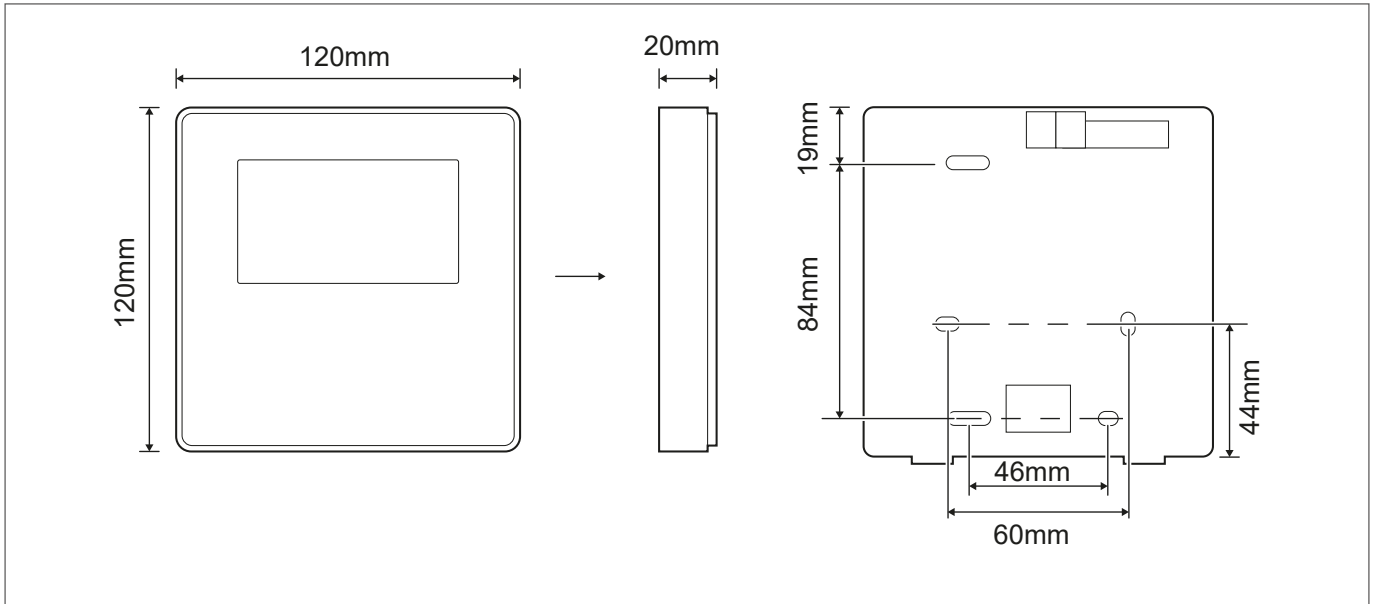

7.2 Wall-mounted installation

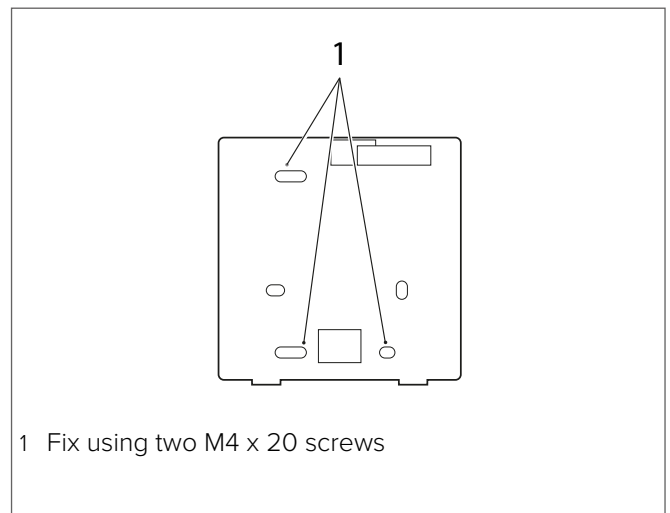
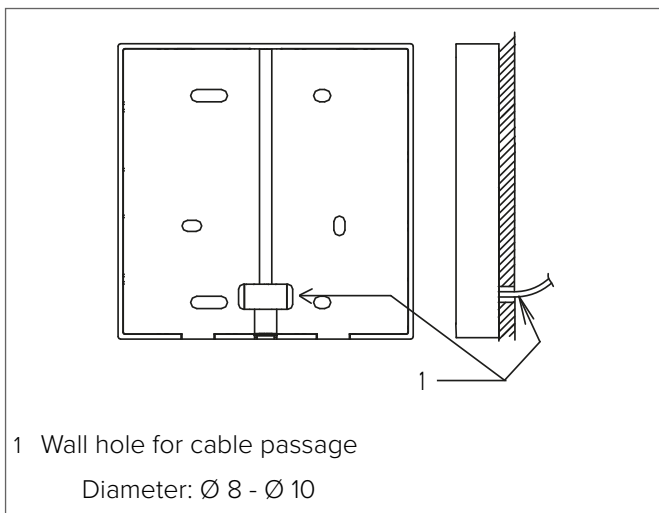
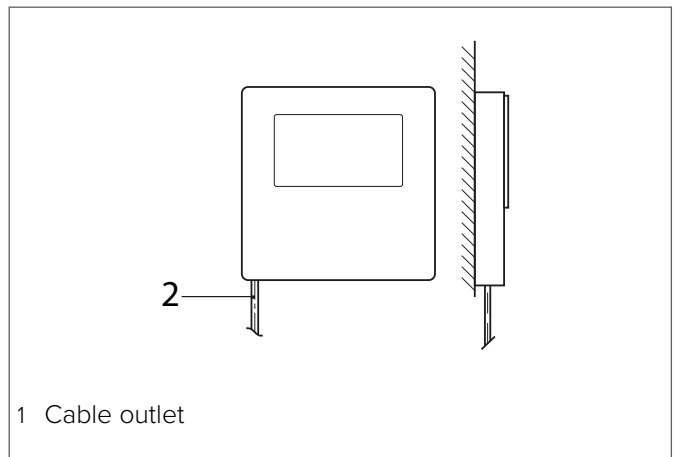
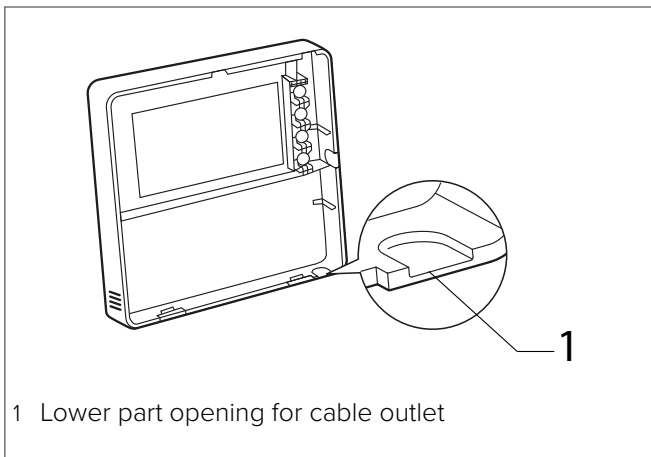

Installation in an uncased box

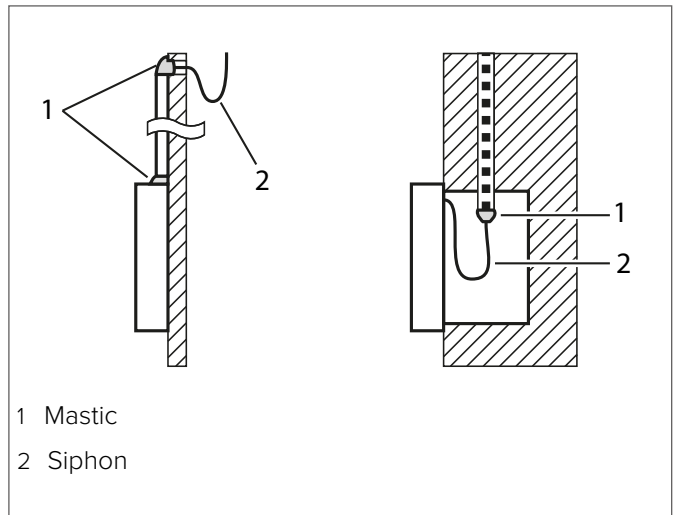
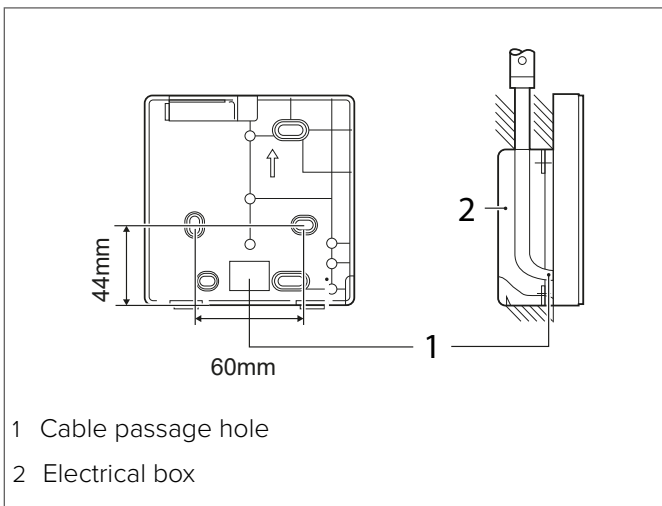
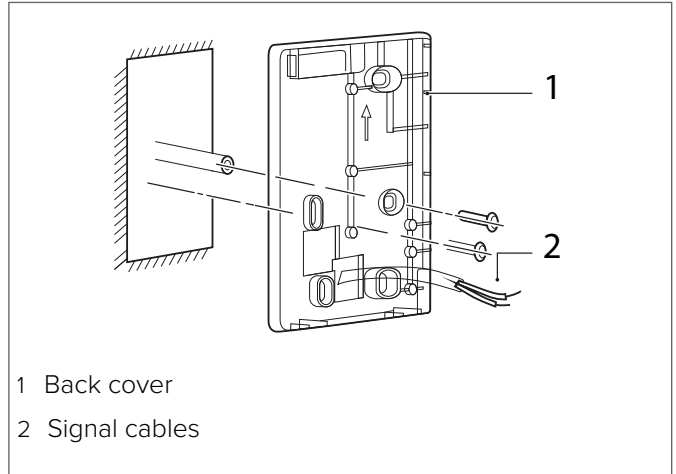
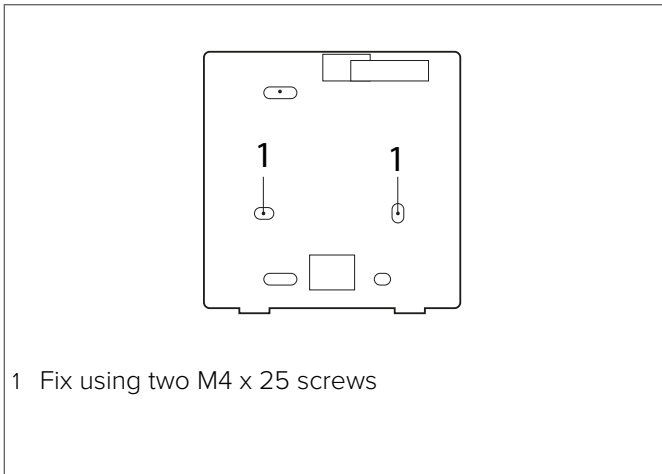

⚠ Prevent water from entering the wired controller, use siphons and mastic to seal the wire connectors during installation.

⚠ Do not crush the communication wire during installation.

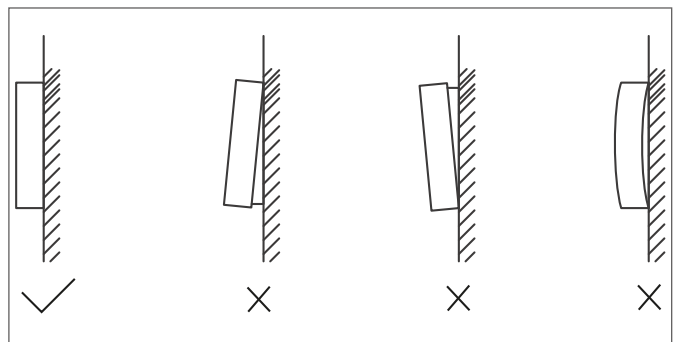
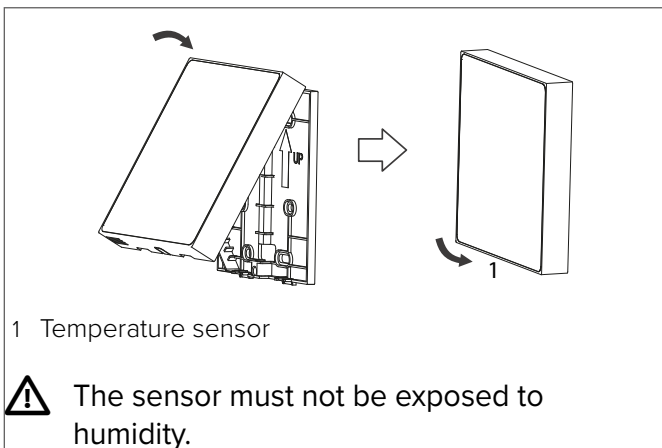

⚠ Over-tightening the screw will buckle the back cover.

8. Water connections

8.1 Condensate drain

The unit is fitted with a standard drain pump.

The condensate must be disposed of in order to avoid damage to people and property

Unit drain connection:

- the connection must not transmit mechanical stresses and must be carried out paying attention not to damage the unit's drain connection
- the piping must have a minimum slope of 5% to allow outflow
- anchor the piping with a suitable number of brackets, otherwise pipe sagging and air pockets obstructing the outflow will occur
- insulate the piping and siphon to prevent condensate drips
- connect the condensation drain to a rainwater drain network
- The connection between the connection and siphon must be airtight

⚠ It is mandatory to install a siphon which, by eliminating the vacuum caused by the fan, prevents the intake of air from the drain piping.

⚠ The customer is required to install a non return valve on the drain piping to prevent the return of liquid when the pump stops.

⊖ DO NOT use white or sewage water drains to avoid the possible inhaling of odours if the water in the siphon evaporates.

8.2 Pump head

The condensation drain pump has a head of 1.2m.

8.3 Condensation drain connection

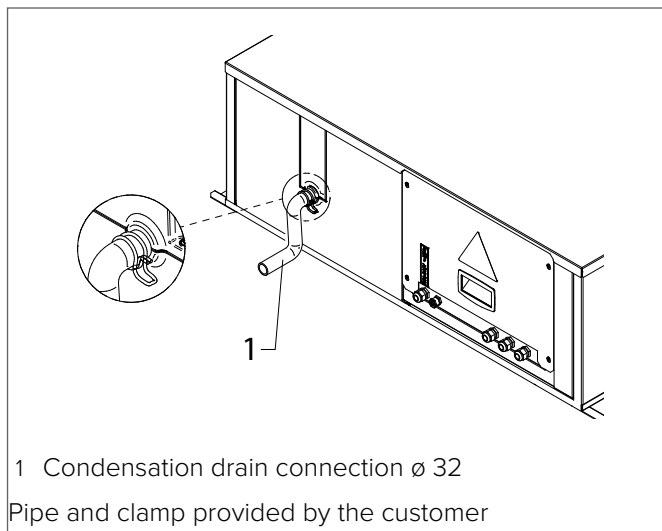

Siphon

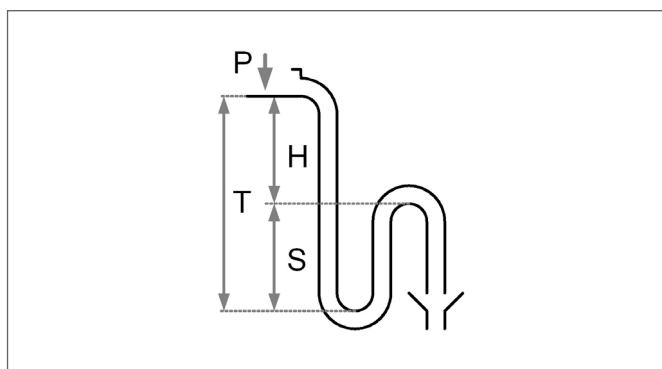
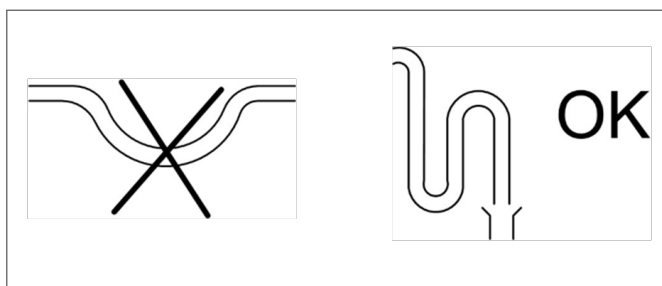

Example:

$$P = 300 \text{ Pa} = 30 \text{ mm}$$

$$T = 2P = 60 \text{ mm}$$

$$S = T/2 = 30 \text{ mm}$$

Siphon height calculation

$$T = 2P$$

$$S = T/2$$

P is the pressure determined by the fan in correspondence of the condense collection bowl (approx. 1 mm = 9.81 Pa)

8.4 Risk of freezing

Prevent the risk of frost if the unit and drain may be subjected to near 0°C temperatures.

For example:

- protect the piping with heating cables laid underneath the insulation
- isolate the piping
- empty in the event of long periods of inactivity.

9. Aeraulic connections

- ⚠ This section is intended exclusively for the Installer.
- ⚠ The aeraulic system and its components must be designed by a qualified technician who shall work according to the rules of good practice and national regulations.
- ⚠ Operate in compliance with safety regulations in force.
- ⚠ The sizing and correct execution of the aeraulic connections are essential to ensure smooth operation of the unit and an adequate level of silence in the room.
- ⚠ When designing and manufacturing the channels, consider **PRESSURE DROPS, AIR FLOWRATE AND SPEED** that must be consistent with the characteristics of the unit.
- ⚠ Particularly consider that pressure drops higher than the unit's available pressure lead to a reduction in the flowrate with consequent unit shutdowns.

Check that:

- the weight of the channels must not burden on the connection flanges
- place anti-vibration joints between channels and unit
- connection to the flanges and between the various sections of the channels must guarantee air seal, avoiding dispersions penalising the overall efficiency of the system
- pressure drops are limited by optimising the circuit, type and number of bends and branches
- large radius bends are used and consider fitting them with deflectors (especially with fast air speed or small radius bends)

9.1 Treated air channelling

- ⚠ The inner surface of the channel must be smooth, allow it to be washed and must not contaminate the air.
- ⚠ Thermally insulate the channels, flanges, silencers, etc. to avoid energy losses and condensation.
- ⚠ To attenuate the noise level, it is advisable to use insulated channels.

DIFFUSERS INLETS GRILLS

Proper air diffusion in the room is decisive for the comfort level and correct operation of the unit.

When choosing and positioning the grills, inlets and diffusers, avoid:

- excessive air speed
- forming of stagnant and stratification areas
- cold air delivery in room
- forming of localised currents (also due to uneven distribution of air)
- excessive room temperature variations, vertically and horizontally
- short circuits of the supply air towards the return air

For sound comfort, consider that:

- the air diffusers must be chosen verifying the sound power generated at nominal flow rate conditions
- the cut-off to diffusers must be carried out with flexible elements
- the return grills must be widely dimensioned

- ⊖ It is forbidden to cover the grills with objects (furniture, cupboards, etc.) that prevent normal air circulation in the rooms.

9.2 Size of connections

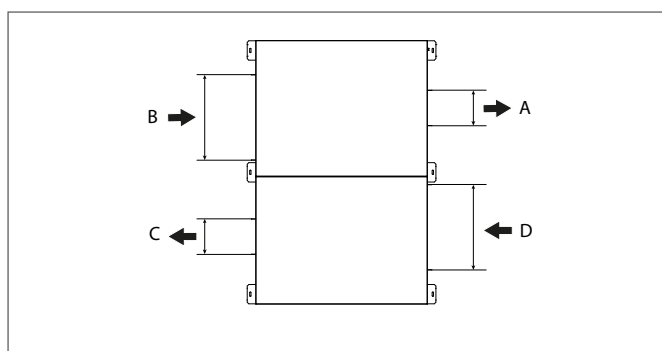

Size 1	Flange	Length	Height
A	Air exhaust	230	110
B	Ambient air return	550	210
C	Ambient air supply	230	110
D	Outdoor air intake	550	210

Size 2	Flange	Length	Height
A	Air exhaust	230	200
B	Ambient air return	550	300
C	Ambient air supply	230	200
D	Outdoor air intake	550	300

Size 3	Flange	Length	Height
A	Air exhaust	230	200
B	Ambient air return	550	480
C	Ambient air supply	230	200
D	Outdoor air intake	550	480

Unit of measurement in mm.

⊖ Avoid recirculation of exhaust/return air

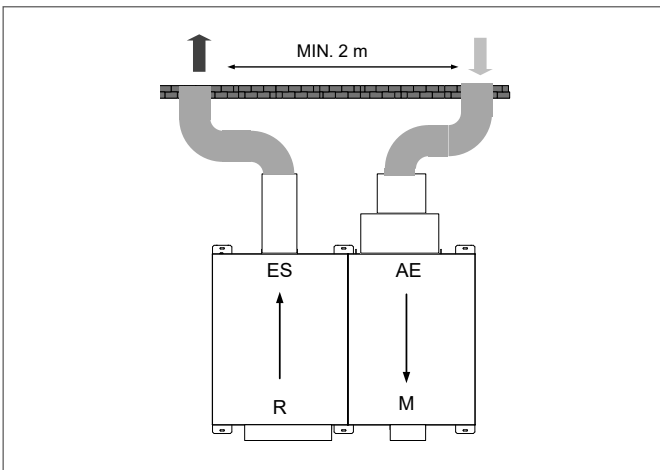
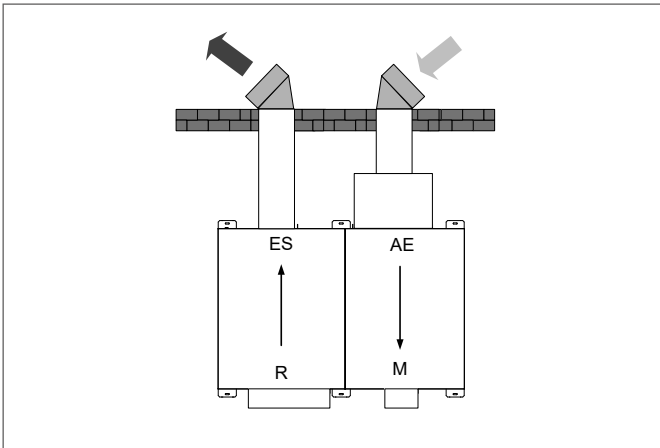
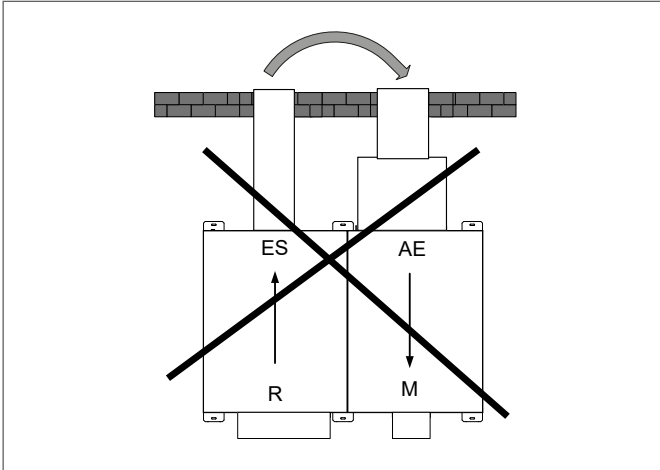

Exhaust/return grille

⚠ Provide grilles to prevent the intrusion of foreign bodies.

Accessory not supplied by the manufacturer.

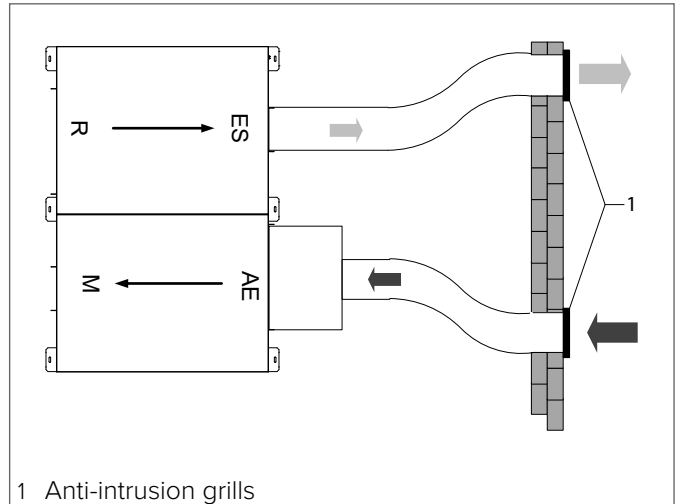

Install on:

Outdoor air intake

- position in an area with a low concentration of impurities (dust, odours, exhaust gases, etc.).

Exhaust outlet

- away from terraces, balconies, neighbouring properties
- avoid upwind areas.

Insulated channel

- ⚠** Thermally insulate the channels on the delivery line to prevent heat losses and condensation.

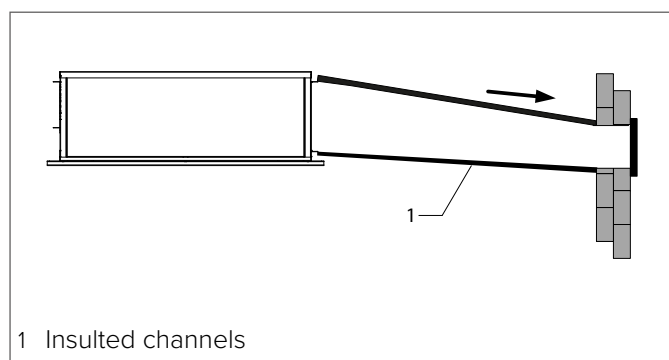
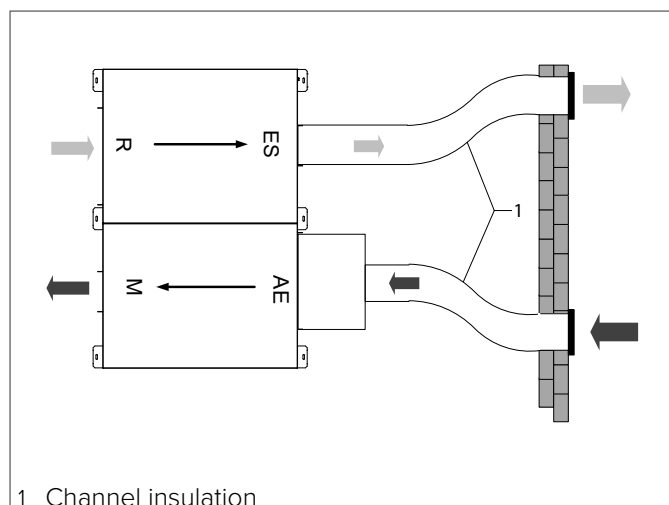

- ⚠** The channels must be sloping down to the unit to prevent condensation or water from returning

Rooftop exhaust/return

For a unit installed in the attic with exhaust/return on the roof, ensure that pipes and roof caps (not supplied by Clivet) are installed.

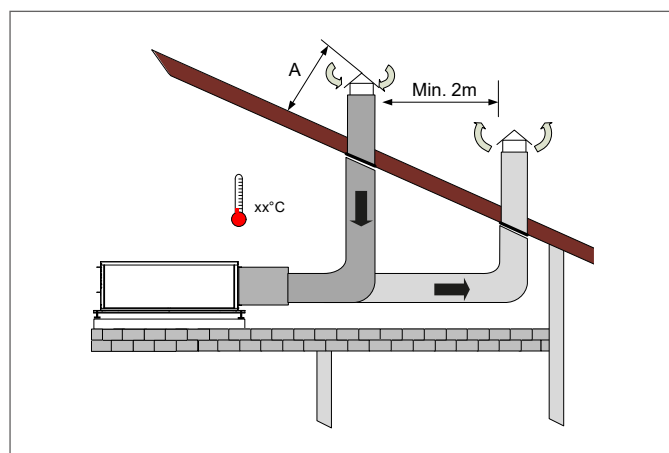

9.3 Aeraulic system

 Before installing the aeraulic system, check the project for the passage of pipes and location of accessories.

Unit location:

- in a suitable room (where the temperature does not fall below 10°C and the ambient return air temperature does not fall below 15°C), away from bedrooms, check the available height with the unit's height and current local regulatory restrictions

Locate the position of the renewal fresh air intake:

- check local regulations (especially the minimum height between the lowest point of the intake and the ground surface)
- avoid excessive proximity to the ground (odour/radon inlet)
- minimum distance of the unit
- install an anti-intrusion grill for small animals or leaves (accessory supplied separately)
- prevent water infiltrations
- avoid proximity to boiler flues, extractors, etc.
- avoid vehicle parking areas
- avoid bypass with stale air exhaust

Locate the position of the exhaust outlet:

- see previous point
- avoid proximity to windows, balconies, etc.
- avoid upwind areas
- avoid pedestrian passages
- avoid garages, basements, unventilated attics

Supply and return box:

- if possible, install in a barycentric position so that the air ducts are of similar length

Locate rooms with inlet: in dedicated rooms

Locate the position of inlets: on the ceiling, wall or floor

Locate rooms with air extraction:

- from dedicated rooms
- avoid intake from the kitchen extractor hood (it is too close to the hob), minimum horizontal distance from the hob ~ 1m

Locate the extraction outlets:





- always high up, a position that facilitates moisture extraction

Check air transit between rooms (gaps under the door about 1 cm) to allow air circulation

10. Electrical connections

- ⚠ The electrical system and its components must be designed by a qualified technician who shall work according to the rules of good practice and national regulations.
- ⚠ All electrical operations should be performed by trained personnel having the necessary requirements by the regulations in force and being informed about the risks relevant to these activities.
- ⚠ Operate in compliance with safety regulations in force.
- ⚠ The power cables and the protection cable section must be defined in accordance with the characteristics of the protections adopted.
- ⚠ The protection devices of the unit power line must be able to stop the presumed short circuit current, whose value must be determined in function of system features.
- ⚠ Refer to the unit electrical diagram (the number of the diagram is shown on the serial number label).
- ⚠ verify that the network has characteristics conforming to the data shown on the serial number label.
- ⚠ Before starting work, verify that the sectioning device at the start of the unit power line is open, blocked and equipped with cartel warning.
- ⚠ The supply line must be disconnectable from the rest of the building's power mains with an all-pole magnetothermic circuit breaker with separation of contacts on all poles, to be implemented in accordance with current laws and regulations.
- ⚠ The protection must be sized in accordance with the electrical data declared by the manufacturer.
- ⚠ Disconnect the power supply before making any connection.
- ⚠ Do not crush cable bundles and prevent them from coming into contact with piping and any sharp edges.
- ⚠ Primarily you have to realize the earthing connection.
- ⚠ Incorrect grounding may cause electric shocks.
- ⚠ All external high voltage loads, if connected to a metal fitting or grounding clip, must be earthed.
- ⚠ The current required for each external load must be less than 0.2 A. If the current required for a single load is greater than 0,2 A, insert a contactor for control.
- ⚠ Install an all-pole disconnection device for overvoltage category III.
- ⚠ Failure to observe this precaution may result in electric shocks.
- ⚠ Power and signal cables should be routed as separately as possible to avoid any interference.
- ⚠ Keep the unit's controller wiring as far away from hot surfaces as possible. It is advisable to use cables with cross-linked polyvinyl chloride sheath.
- ⚠ For the electrical connection, use a cable of sufficient length to cover the entire distance without any connection work. Do not use extension cords. Do not apply other loads on the power supply.
- ⚠ If the power cable is damaged, it must be replaced by qualified personnel and in accordance with current national regulations.
- ⚠ The manufacturer is not liable for any damage caused by failure to install a grounding system or failure to comply with

the diagrams.

-  Check the voltage values which must be within the limits: 220-240V +/- 6%.
-  Before power the unit, make sure that all the protections that were removed during the electrical connection work have been restored.
-  Prevent dust, insects or rodents from entering the electrical panel as they can damage components and cables.
-  Do not drill holes in the electrical panel.
-  It is forbidden to connect the earth wire to gas or water pipes, lightning rods or telephone ground.

10.1 Electrical data

The serial number label reports the unit specific electrical data, included any electrical accessories.

The electrical data indicated in the technical bulletin and in the manual refer to the standard unit, accessories excluded.

The matriculation plate shows the indications foreseen by the standards, in particular:

- Voltage
- F.L.A.: full load ampere, absorbed current at maximum admitted conditions
- F.L.I.: full load input, full load power input at max. admissible condition
- Electrical wiring diagram Nr

10.2 Remote controls

Refer to the unit electrical diagram (the number of the diagram is shown on the serial number label).

Access:

- Unscrew the panel screws
- Identify the control
- Connect the control

HMI keypad

Multi-core 5x0.75 mm² shielded untwisted cable

Power supply connection

Power supply 220/240 ~50HZ

Cable section: max. 4mm² (double insulation and unsheathed)

Size 1 : min. 0.75mm²

Size 2 : min. 1.5mm²

Size 3 : min. 4mm²

10.3 Connections to be provided by customer

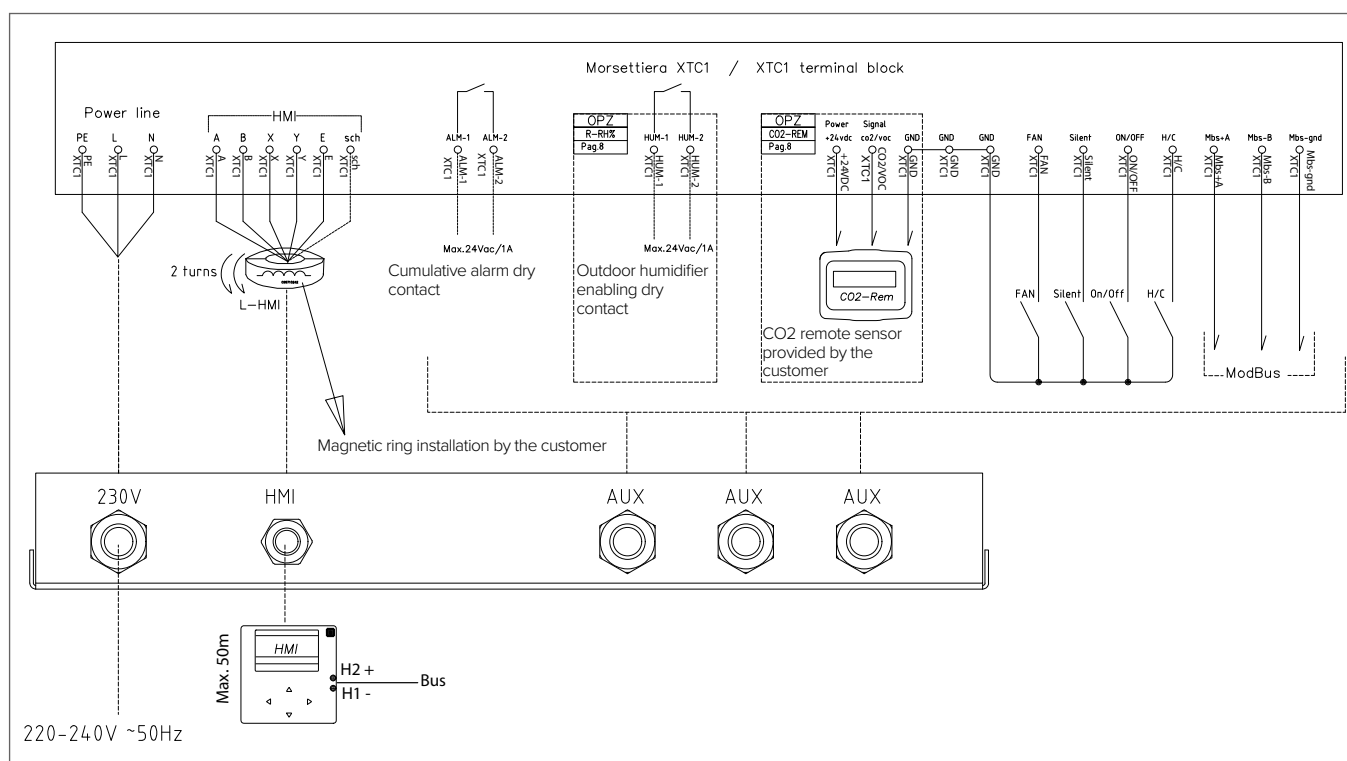

Remote summer-winter (heat/cool) selector switch

Used to change the operating mode from heating to cooling from an external control.

On - Off

Switches the unit on/off from a remote control.

Double airflow set point

Allows the airflow set point to be changed according to the speeds set on the HMI.

Silent

Reduces the fan speed and limits compressor frequency.

Two types of mode can be set: silent, supersilent.

Fan

Only the fans are switched on and there is no temperature and humidity control, the compressor is disabled.

Modbus

There are 2 ports:

- one on the HMI: the serial communication connecting cable must be shielded and twisted. Max. serial line length 1000m.
- one on the unit (customer's terminal block): the serial communication connecting cable must be shielded and twisted. Max. line length between master device and unit 3m.

Terminal block

SIZE 1

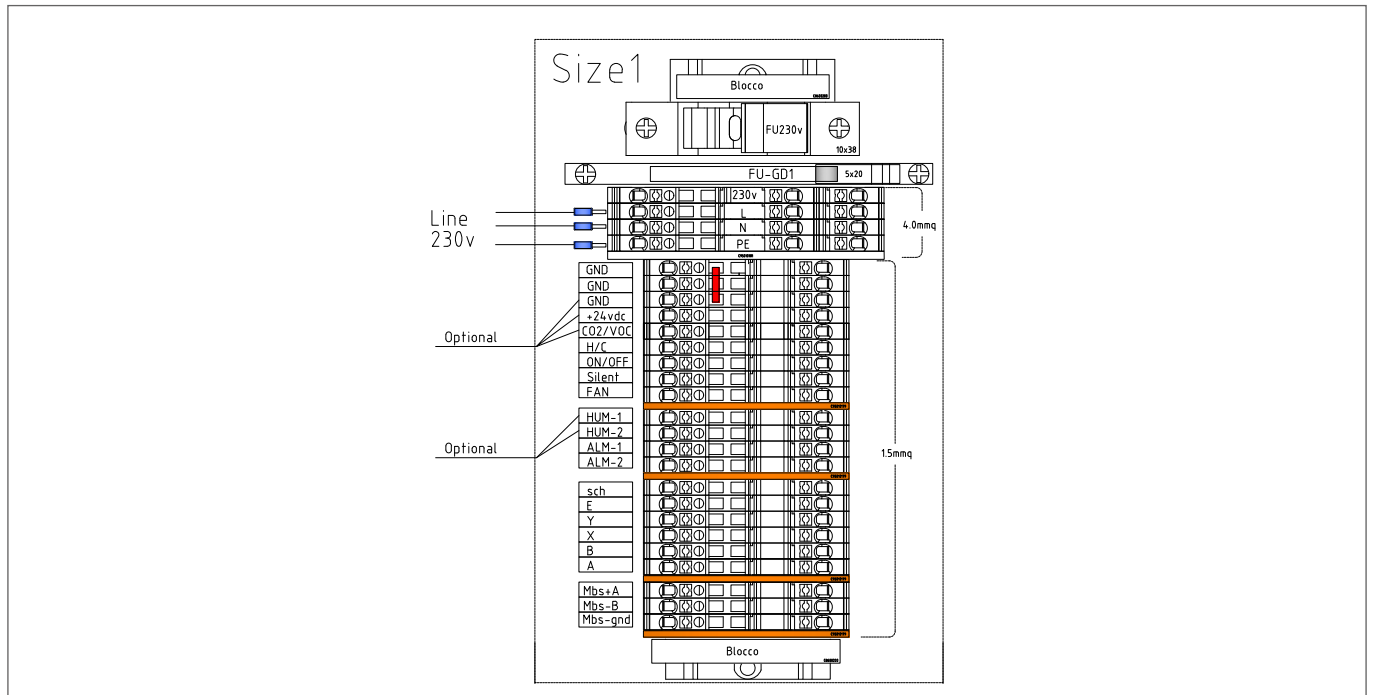

Electrical panel

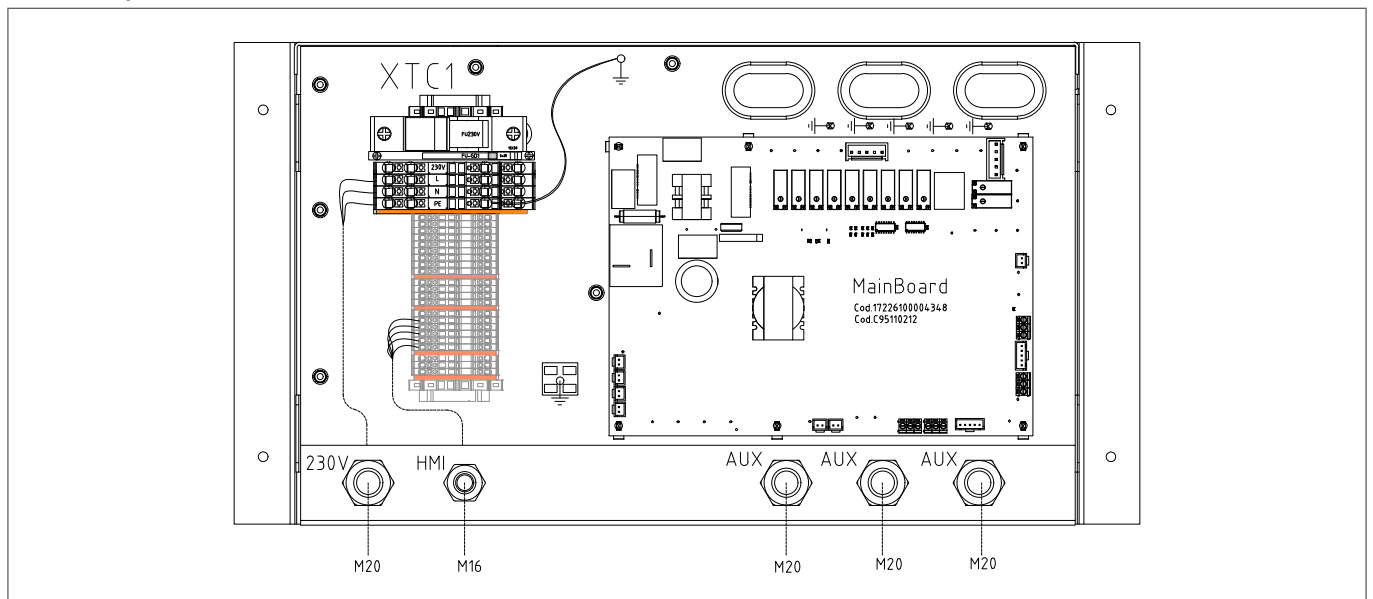

Terminal block

SIZE 2 - SIZE 3

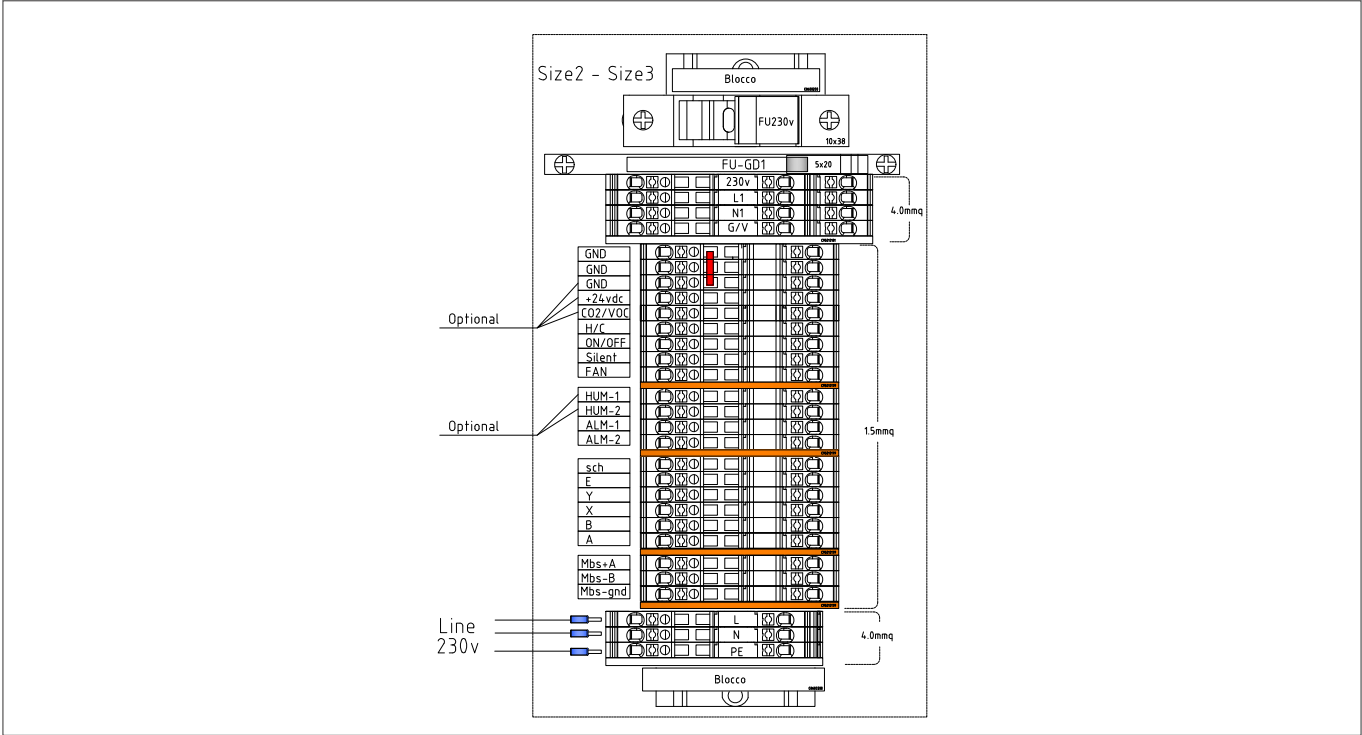

Electrical panel

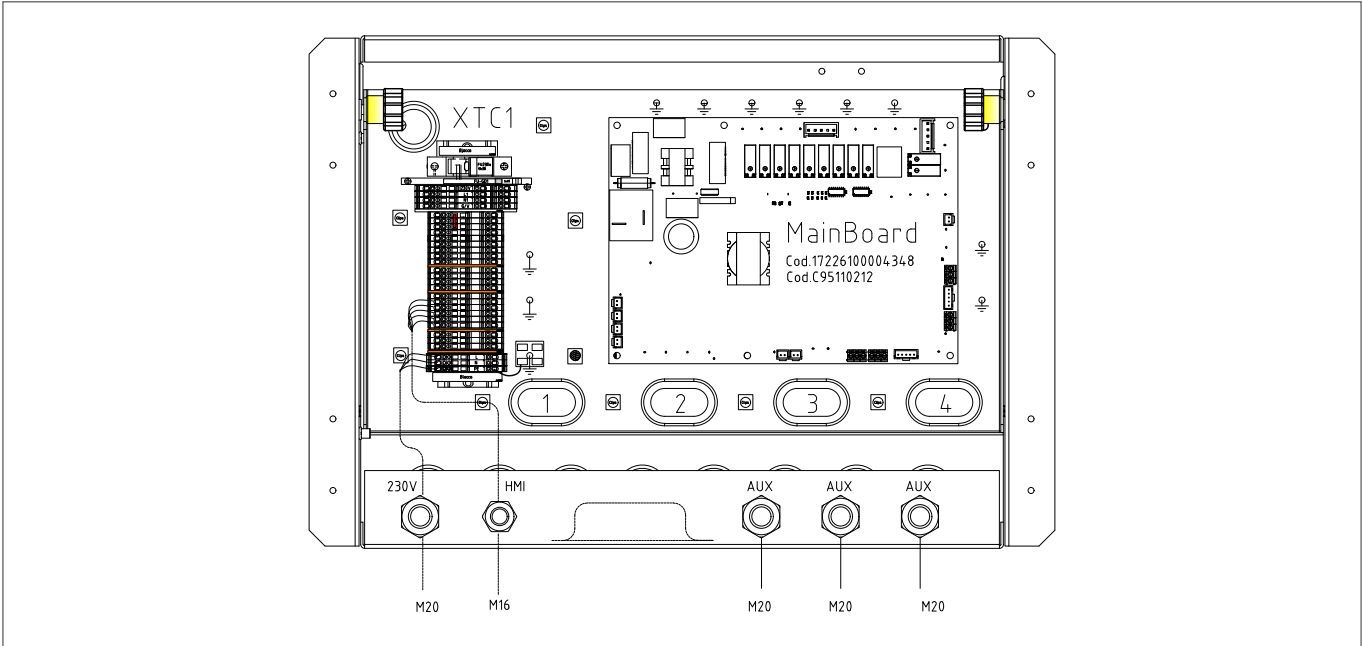

11. Start-up

The indicated operations should be done by qualified technician with specific training on the product.

Upon request, the service centres performing the start-up.

The electrical, water connections and the other system works are by the installer.

Agree upon in advance the start-up data with the service centre.

Before checking, please verify the following:

- the unit should be installed properly and in conformity with this manual
- the electrical power supply line should be isolated at the beginning
- the unit isolator is open, locked and equipped with the suitable warning
- make sure no voltage is present

 After turning off the power, wait at least 5 minutes before accessing to the electrical panel or any other electrical component.

 Before accessing check with a multimeter that there are no residual voltage.

11.1 Refrigeration circuit

 Only use the pressure sockets if the refrigerant circuit needs to be charged or discharged.

11.2 Aeraulic circuit

Check that:

- the rooms are clean (no dirt)
- any dampers are open and calibrated
- the air filters have not been removed from the unit and are clean (any ventilation tests and the initial period of operation lead to “washing” the channels, resulting in premature and severe clogging of the filters, which must be cleaned or replaced)
- the ducting is completed, connected and free from obstructions
- grills, outlets and diffusers are free from obstructions (furniture, shelving, etc.), open and pre-calibrated to ensure correct air diffusion.

11.3 Electric circuit

Check that:

- the unit is connected to the earthing system
- the conductors are tightened: vibrations caused by handling and transport might cause them to come loose
- the unit is powered by closing the disconnecting

device, but leave it on OFF

Check the network voltage and frequency values, which must be within the limits:

220/240 ~50HZ +/- 6%

 Working outside of these limits can cause irreversible damages and voids the warranty.

11.4 Voltages

Check that the air temperatures are within the operating limits.

With the unit operating in stable conditions, check:

- power supply voltage
- total absorption of the unit
- absorption of the single electric loads.

11.5 Remote controls/signals

Check that the remote controls used are wired and enabled with the relevant parameters:

- ON-OFF
- Double airflow set point
- Summer-Winter
- Silent/Super Silent
- Fan

11.6 Start-up report

Identifying the operating objective conditions is useful to control the unit over time.

With unit at steady state, i.e. in stable and close-to-work conditions, identify the following data:

- total voltages and absorptions with unit at full load
- absorptions of the different electric loads (compressors, fans, pumps etc)
- temperatures and flows of the different fluids (water, air) both in input and in output from the unit
- temperature and pressures on the characteristic points of the refrigerating circuit (compressor discharge, liquid, intake)

The measurements must be kept and made available during maintenance interventions.

11.7 2014/68/UE PED directive

DIRECTIVE 2014/68/UE PED gives instructions for installers, users and maintenance technicians as well.

Refer to local regulations; briefly and as an example, see the following:

Compulsory verification of the first installation:

- only for units assembled on the installer's building site (for ex. Condensing circuit + direct expansion unit)

Certification of setting in service:

- for all the units

Periodical verifications:

- to be executed with the frequency indicated by the Manufacturer (see the "maintenance inspections" paragraph)

11.8 Start-up sequence

The indicated operations should be done by qualified technician with specific training on the product.

Upon request, the service centres performing the start-up.

The electrical, water connections and the other system works are by the installer.

Agree upon in advance the star-up data with the service centre.

Before checking, please verify the following:

- the unit should be installed properly and in conformity with this manual
- the electrical power supply line should be isolated at the beginning
- the unit isolator is open, locked and equipped with the suitable warning
- make sure no voltage is present

 After turning off the power, wait at least 5 minutes before accessing to the electrical panel or any other electrical component.

 Before accessing check with a multimeter that there are no residual voltage.

 Before starting the unit, ensure that there is no dust or debris in the ambient and the ducting is free from obstructions.

The following check list is a brief reminder of the points to be checked and the operations to start the unit.

For details on the points mentioned, refer to the various chapters in the manual.

Preliminary checks - Unit power supply OFF		✓
1	Safe access	
2	The functional spaces of the unit are respected	
3	Structure integrity	
4	The unit is level	
5	The anti-vibration mounts are installed correctly	
6	The anti-intrusion grille for small animals and leaves is installed (option)	
7	Air flow: correct intake and supply (no bypass)	
8	The aeraulic system is completed	
9	The supply channel in the room and the air exhaust channel are insulated	
10	The vibration damping joints between the channel and the unit are installed (e.g. fabric channels)	
11	Condensation drain with siphon - sloping	
12	Connections performed by customer	
13	Grounding connection	
14	An overload protection fuse and a differential circuit-breaker have been installed	
15	Power cables separated from signal cables	

11.9 Start-up sequence

During the initial start-up procedure, the airflow is set (by the HMI) to control the balanced amount of air entering and exiting the room.

Doors and windows fitted.

External doors and windows closed.

Instrumentation required in addition to normal instrumentation.

- Propeller anemometer
- Aeraulic system design with flowrate in the individual rooms
- Rectangular and circular extension cords to be placed on the room inlets and outlets in order to even out air flows from the supply nozzles and extraction valves whose flowrates are measured.



Start-up sequence		✓
1	Start-up sequence	
2	Unit powered	
3	Switch on the unit	
4	Check for abnormal vibrations or noise with compressor and fans switched on	
5	Check that outlets in the room and any dampers in the channels are open	
6	Check the airflow (Anemometer) by taking a measurement directly on the external inlets and outlets	
7	Unable to access the external outlets, check the airflow in the room using the following formula: Flowrate m ³ /h = Area (m ²) x Speed (m/s) x 3600 seconds	
8	Check fan operation	
9	With the compressor switched on, check that the unit's power supply voltage ranges between 220-240 V	
10	Check for abnormal vibrations	
11	Instruct the user on how to switch on, switch off, change set-points and clean filters.	
12	Collect the machine documentation and hand it over to the customer with the completed and signed commissioning report	
13	Connections performed by customer	
14	Grounding connection	
15	An overload protection fuse and a differential circuit-breaker have been installed	
16	Power cables separated from signal cables	

11.10 Airflow tables

Setting the values on the keypad (paragraph 1.12)

S1

Speed setting	Airflow m ³ /h
W3	300
W4	400
W5	500
W6	600
W7	720

S2

Speed setting	Airflow m ³ /h
W3	700
W4	900
W5	1000
W6	1350
W7	1500







S3

Speed setting	Airflow m ³ /h
W3	1400
W4	1600
W5	1800
W6	2000
W7	2500















12. Control

12.1 Explanation of buttons



Buttons	Name	Function
	MENU	To open the various menus from the HOME page.
	OK	To confirm an operation.
	UNLOCK	Long press to unlock/lock the keypad.
	ON/OFF	To set the ON / OFF function.
	LEFT - RIGHT DOWN - UP	To move the cursor, change the selection or change the set value. The parameter can be quickly changed with a long press.
	BACK	To return to the previous level. Press to exit the current page and return to the previous page. Long press to return straight to the home screen.

12.2 Explanation of symbols

Icon	Meaning
	Heating mode
	Cooling mode
	Automatic mode
	Fan mode
	OFF: unit off
	Wi-Fi: indicates connection with the mobile phone
24 °C	Room temperature, measured by probe T1 When adjusting the temperature, the setpoint is indicated
	Compressor: indicator on when the compressor is running
	Defrosting: indicator on when the unit is defrosting
	Humidity control: indicator on when the unit is in cooling mode and the compressor is running
	Timer: indicator on when a valid timer (weekly schedule) is set
	Alarm: indicator on when there is a fault or a protection is tripped
E01	Indicates the specific information of a current fault or protection
	Lock: indicator on when the keypad is locked
	Silent: indicator on when the unit is in silent/super silent mode
	Comfort: indicator on when the unit is in cooling/heating/auto mode and the compressor is running
	Outdoor temperature

12.3 Button Lock / Unlock

Press UNLOCK for 3 seconds to lock/unlock the screen.

If any key is pressed when the keypad is locked, the LOCK icon flashes.



12.4 Switching on / off

Press ON/OFF to switch-on/off.

If a timer is active, the unit cannot be switched off.

A password is required to disable the timer.

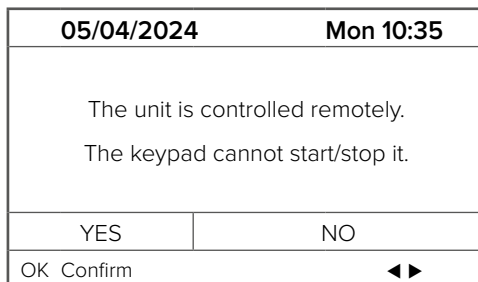

12.5 temperature setting

▶ Press Left - Right to select.

▶ Press Up - Down to change.

If no operations are performed for more than 3 seconds, the system automatically saves the settings.



Temperature setting range:

	MIN °C	MAX °C	Factory default °C
Cooling	22	28	24
Heating	17	24	20
Auto	17	28	22

The temperature cannot be controlled:

- with the AUTO TEMPERATURE SETTING mode enabled
- with the timer active

12.6 Navigation menu

▶ Press MENU

▶ Press Up - Down to select each menu option.

▶ Press OK to open the relevant submenu.

▶ Press BACK to return to the home page.

▶ Press MENU to return to the previous page.

MENU	
OPERATION MODE	
TIMER SETTING	
FUNCTION SETTING	
MAIN PARAMETER	
INTERFACE SETTING	
SERVICE INFORMATION	
OK	ENTER 1/2 ▼▲

MENU	
ASSISTANCE SETTING	
WLAN SETTING	
OK	ENTER 1/2 ▼▲

12.7 Operation mode

- ▶ Select the mode with Up and Down.
- ▶ Confirm with OK.

After 10 seconds without any action, the mode is automatically saved.

MENU	
OPERATION MODE	
TIMER SETTING	
FUNCTION SETTING	
MAIN PARAMETER	
INTERFACE SETTING	
SERVICE INFORMATION	
OK	ENTER 1/2 ▼▲

Default values for each mode:

Heating	20°C
Cooling	24°C
Automatic	22°C
Fan	-

 Function enabled only if parameter ENMode = 1.

12.8 Timer

A daily or weekly schedule can be set.

Select TIMER SETTING with Up and Down and press OK.

MENU	
OPERATION MODE	
TIMER SETTING	
FUNCTION SETTING	
MAIN PARAMETER	
INTERFACE SETTING	
SERVICE INFORMATION	
OK	ENTER 1/2 ▼▲

- ▶ Press Left - Right to select the password value
 - ▶ Press Up - Down to enter the password value.
- The password is 123 and cannot be changed.

TIMER SETTING			
PLEASE INPUT THE PASSWORD			
000			
OK	ENTER	▼▲ ADJUST	◀▶

After entering the correct password, the display shown is as follows:

TIMER SETTING			
DAILY TIMER			
WEEKLY SCHEDULE SETTING			
WEEKLY SCHEDULE CHECK			
CANCEL TIMER			
OK	ENTER	▼▲	

12.9 Daily timer

- ▶ Select DAILY TIMER with Up and Down.
- ▶ Press OK.
- ▶ Press Up and Down to select timer T1 - T5.
- ▶ Press ON/OFF to enable/disable the timer selected.
- ▶ Press Left - Right to select each option to be set.
- ▶ Press Up - Down to set the temperature.
- ▶ Press Up - Down to set the start and end time.
- ▶ Press OK to confirm the setting and return to the previous page.
- ▶ Press BACK to delete the setting and return to the previous page.

DAILY TIMER				
N.	S/N	SET	START	END
T1	<input type="checkbox"/>	24 °C	00:00	00:00
T2	<input type="checkbox"/>	24 °C	00:00	00:00
T3	<input type="checkbox"/>	24 °C	00:00	00:00
T4	<input type="checkbox"/>	24 °C	00:00	00:00
T5	<input type="checkbox"/>	24 °C	00:00	00:00
ON/OFF	SELECT	◀▶ ▼▲		

12.10 Weekly timer

- ▶ Select WEEKLY SCHEDULE SETTING with Up and Down.
- ▶ Press OK

TIMER SETTING				
DAILY TIMER				
WEEKLY SCHEDULE SETTING				
WEEKLY SCHEDULE CHECK				
CANCEL TIMER				
OK	ENTER	▼▲		

- ▶ Press Left - Right - Up - Down to select the days.
- ▶ Press ON/OFF to confirm / delete the days selected.
- ▶ Press OK to go to the next screen.

WEEKLY SCHEDULE SETTING				
CHOOSE THE SETTING DAYS				
MON <input type="checkbox"/> TUE <input type="checkbox"/> WED <input type="checkbox"/> THU <input type="checkbox"/>				
FRI <input type="checkbox"/> SAT <input type="checkbox"/> SUN <input type="checkbox"/>				
ON/OFF	SELECT	◀▶ ▼▲		

- ▶ Press Up and Down to select timer T1 - T5.
- ▶ Press ON/OFF to enable/disable the timer selected.
- ▶ Press Left - Right to select each option to be set.
- ▶ Press Up - Down to set the temperature.
- ▶ Press Up - Down to set the start and end time.
- ▶ Press OK to confirm the setting and return to the previous page.
- ▶ Press BACK to delete the setting and return to the previous page.

DAILY TIMER				
N.	S/N	SET	START	END
T1	<input type="checkbox"/>	24 °C	00:00	00:00
T2	<input type="checkbox"/>	24 °C	00:00	00:00
T3	<input type="checkbox"/>	24 °C	00:00	00:00
T4	<input type="checkbox"/>	24 °C	00:00	00:00
T5	<input type="checkbox"/>	24 °C	00:00	00:00
ON/OFF	SELECT	◀▶ ▼▲		

- ▶ Select WEEKLY SCHEDULE CHECK with Up and Down.
- ▶ Press OK

TIMER SETTING				
DAILY TIMER				
WEEKLY SCHEDULE SETTING				
WEEKLY SCHEDULE CHECK				
CANCEL TIMER				
OK	ENTER	▼▲		

The WEEKLY CHECK is used to display, but not change, the weekly schedule.

- ▶ Press Up - Down to move from one week day to the next.

WEEKLY SCHEDULE CHECK				
DAY	NO.	SET	START	END
MON <input type="checkbox"/>	T1 <input type="checkbox"/>	24 °C	06:00	08:00
	T2 <input type="checkbox"/>	24 °C	12:00	14:00
	T3 <input type="checkbox"/>	24 °C	18:00	20:00
	T4 <input type="checkbox"/>	24 °C	22:00	22:30
	T5 <input type="checkbox"/>	24 °C	23:00	23:50
▼▲				

12.13 Deleting all TIMERS

- ▶ Select CANCEL TIMER with Up and Down.
- ▶ Press OK
- ▶ Press YES to delete all daily and weekly timer settings.

TIMER SETTING				
DAILY TIMER				
WEEKLY SCHEDULE SETTING				
WEEKLY SCHEDULE CHECK				
CANCEL TIMER				
OK	ENTER	▼▲		

12.11 Weekly schedule check

CANCEL TIMER	
The timer function is on. Do you want to cancel the timer function?	
YES	NO
OK Confirm ◀▶	

05/04/2024		Lun 10:35	
The auto temperature setting function is on. Do you want to cancel the auto temperature setting function?			
YES		NO	
OK Confirm ◀▶			

12.14 Automatic temperature

- ▶ Select FUNCTION SETTING
- ▶ Press OK

MENU	
OPERATION MODE	
TIMER SETTING	
FUNCTION SETTING	
MAIN PARAMETER	
INTERFACE SETTING	
SERVICE INFORMATION	
OK	ENTER 1/2 ▼▲

- ▶ Select AUTO TEMP. SETTING
- ▶ Press ON/OFF to enable/disable the mode.
- ▶ Press OK to confirm.
- ▶ Press BACK to cancel the operation and return to the previous page.

FUNCTION SETTING	
AUTO TEMP. SETTING	OFF
SILENT MODE SETTING	NONE
FILTER CLEANING SETTING	
OK	ADJUST ▼▲

When AUTO TEMP. SETTING = ON, manual temperature control is disabled.

When the automatic mode is active, the temperature cannot be changed manually.

To cancel the mode.

- ▶ Press Left - Right and select YES.
- ▶ Press OK
The AUTO TEMP. SETTING mode is disabled.
- ▶ Press BACK to return to the previous page.

When the HMI is set on automatic mode and automatic temperature, the unit follows the control logic.

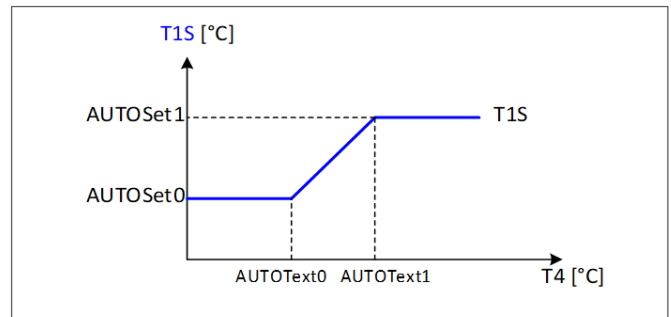

T1S: setpoint temperature

T4: ambient temperature

The AUTOText0, AUTOText1, AUTOSet0 and AUTOSet1 parameters can be set from the HMI.

12.15 Silent and Super Silent mode

- ▶ Select SILENT MODE SETTING
- ▶ Press OK to confirm
- ▶ Press Left - Right to choose the level:
 - none
 - normal
 - super
- ▶ Press BACK to return to the previous page.

FUNCTION SETTING	
AUTO TEMP. SETTING	OFF
SILENT MODE SETTING	NONE
FILTER CLEANING SETTING	
OK	ADJUST ▼▲

12.16 Filter cleaning

- ▶ Select FILTER CLEANING SETTING
- ▶ Press OK.

FUNCTION SETTING	
AUTO TEMP. SETTING	OFF
SILENT MODE SETTING	NONE
FILTER CLEANING SETTING	
OK	ADJUST ▼▲

RECLOCK	
The filter has been cleaned. Start a new periodic filter cleaning schedule?	
YES	NO
OK Confirm ◀▶	

- ▶ Press Left - Right to choose the filter cleaning time:
 - none
 - 500.....10000 hours
- ▶ Press OK

FILTER CLEANING SETTING	
PERIODIC TIME SETTING	NONE
RECLOCK	
◀▶	ADJUST ▼▲

12.17 Rescheduling filter cleaning with RECLOCK

- ▶ Select RECLOCK
- ▶ Press OK

FILTER CLEANING SETTING	
PERIODIC TIME SETTING	NONE
RECLOCK	
◀▶	ADJUST ▼▲

- ▶ To reschedule the function.
- ▶ Press Left - Right and select YES.
- ▶ Press OK.

The fan operating time is reset, to set a new filter cleaning cycle.

12.18 Interface settings

- ▶ Select INTERFACE SETTING
- ▶ Press OK

MENU	
OPERATION MODE	
TIMER SETTING	
FUNCTION SETTING	
MAIN PARAMETER	
INTERFACE SETTING	
SERVICE INFORMATION	
OK	ENTER 1/2 ▼▲

- ▶ Press Up - Down - Left - Right and ON/OFF to set:
 - Language in EN - FR - IT - ES - PL - PT - DE
 - Backlight = screen light
 - Buzzer
 - Time
 - Date
 - Screen locking time = screen lock (from 60 to 240 seconds) default is 120 seconds

INTERFACE SETTING	
BACKLIGHT	ON
BUZZER	ON
LANGUAGE	EN
TIME	12:00
DATE	01-01-2024
SCREEN LOCK TIME	120S
◀▶	ADJUST ▼▲

12.19 Alarm display

- ▶ Select SERVICE INFORMATION
- ▶ Press OK.

MENU	
OPERATION MODE	
TIMER SETTING	
FUNCTION SETTING	
MAIN PARAMETER	
INTERFACE SETTING	
SERVICE INFORMATION	
OK	ENTER 1/2 ▼▲

- ▶ Select ERROR RECORD
Enter PASSWORD 321
- ▶ Press OK.

SERVICE INFORMATION	
SERVICE PARAMETER	
ERROR RECORD	
OK	Confirm 1/1 ▼▲

- ▶ Press Up - Down to scroll through the alarms.
(max 24 errors displayed, at the 25th error the 1st error is automatically deleted)
- ▶ Press OK to see the alarm description.

ERROR RECORD		
1	E1	14:50 05-03-2024
2	E2	14:40 05-03-2024
3	E3	14:30 05-03-2024
4	E4	14:30 05-03-2024
5	E5	14:10 05-03-2024
6	E6	14:50 05-03-2024
OK	ENTER	1/4 ▼▲

ERROR RECORD	
E1 The communication fault between main board and HMI	
OK	Confirm

12.20 Service information

The menu is used by the installer or the support technician to check the operation parameters.

- ▶ Select SERVICE INFORMATION
- ▶ Press OK

MENU	
OPERATION MODE	
TIMER SETTING	
FUNCTION SETTING	
MAIN PARAMETER	
INTERFACE SETTING	
SERVICE INFORMATION	
OK	ENTER 1/2 ▼▲

- ▶ Select SERVICE PARAMETER
- ▶ Press OK
- ▶ Press Up - Down to scroll

Unit statuses are displayed on the following mask.

SERVICE PARAMETER	
Operation mode	COOL
Compressor frequency	32HZ
Current	4A
Voltage	230V
Comp. Run Time	10H
Comp.Start-Up Number	2500
EXV opening	240P
Supply fan speed level	3
Exhaust fan speed level	3
Supfan run time	1000H
Filter-cpt Setting	10000H
Damper output	OFF
Aux- Heater	ON
Aux-Heater Voltage Output	5V
Humidifier state	ON
Electrical filter state	1
TS Set Temp.	24C°
T1 Indoor Temp.	35C°
T4 Outdoor Temp.	35C°
T2 Supply Air Coil Temp.	10C°
T2b Supply Air Coil Temp.	35C°
TC Supply Air Temp.	35C°
T3 Exhaust Air Coil Temp.	52C°
TP Comp.Discharge Temp.	85C°
URsu Supply air humidity	45%
BMS address	1
Main software	V09
Module E2 software	V09
HMI Software	V13

12.21 Service information

 The OPERATION PARAMETERS menu is used by the installer or the technician to check the operation parameters.

The values shown on the pages are only indicative.

- ▶ Press MENU
- ▶ Select ASSISTANCE SETTING
- ▶ Enter PASSWORD
- ▶ Press OK

ASSISTANCE SETTING	
1 OPERATION PARAMETER	
2 HUMIDITY PARAMETER	
3 RESET COMPRESSOR START TIMES	
4 MANUALLY DEFROST	
5 ERROR RECORD REMOVE	
6 CANCEL ASSISTANCE SETTING	
OK	ENTER ▼▲

- ▶ Select OPERATION PARAMETER
- ▶ Press Up - Down to scroll
- ▶ Press Adjust to change

The operation parameters are displayed on the following 3 screens.

1. OPERATION PARAMETER		
1.01	AUTOText0	15°C
1.02	AUTOText1	24°C
1.03	AUTOSet0	19°C
1.04	AUTOSet1	15°C
1.05	EnOnOff	1
1.06	EnMode	1
◀▶	ADJUST	1/3 ▼▲

1. OPERATION PARAMETER		
1.07	DeadZone	2°C
1.08	SupFanSet	6
1.09	SupFanSet2	7
1.10	OffsetT 1	0°C
1.11	PoweroffMem	1
1.12	BMS A dd Set	1
◀▶	ADJUST	2/3 ▼▲

1 OPERATION PARAMETER		
1.13	AUTOText0	
1.14	AUTOText1	11
◀▶	ADJUST	3/3 ▼▲

12.22 Dehumidification settings

- ▶ Press MENU
- ▶ Select ASSISTANCE SETTING
- ▶ Enter PASSWORD
- ▶ Press OK
- ▶ Select HUMIDITY PARAMETER

Enable parameter: 2.01 EnProbeUrSup =1

Set parameter: 2.03 DehumComModeSet (value 0,1,2)

0 = standard (10g/kg)

1 = Low humidity (8g/kg)

2 = eco (12g/kg)

2. HUMIDITY PARAMETER		
2.01	EnProbeUrS u p	1
2.02	OffsetUrS u p	10%
2.03	DehumConModeSet	0
2.04	HumCorrFanSpe _	1
2.05	EnProbeUrIn	1
2.06	OffsetUrIn	5%
◀▶	ADJUST	1/2 ▼▲

2. HUMIDITY PARAMETER		
2.07	ENProbeVOC&CO2	1
2.08	OffsetVOC&CO2	500PPM
◀▶	ADJUST	1/2 ▼▲

12.23 Dehumidification (from Modbus)

From the keypad enable parameter: 2.01 EnProbeUrSup =1

Modbus:

Set parameter: 222 DehumComModeSet (value 0,1,2)

0 = Standard (10g/kg)

1 = Low humidity (8g/kg)

2 = eco (12g/kg)

12.24 Compressor drive reset

To delete the number of compressor starts and the compressor operating time.

- ▶ Select YES
- ▶ Press OK

3. RESET COMPRESSOR START TIMES	
Do you want to reset the compressor starting times and operation time?	
YES	NO
OK Confirm ◀▶	

12.25 Manual defrosting

To start manual defrosting of the unit.

- ▶ Select YES
- ▶ Press OK

4. MANUALLY DEFROST	
Do you want to manually defrost?	
YES	NO
OK Confirm ◀▶	

12.26 Deleting alarms

To delete all alarms

- ▶ Select YES
- ▶ Press OK

5. ERROR RECORD REMOVE	
Do you want to remove the error record?	
YES	NO
OK Confirm ◀▶	

12.27 Deleting settings

Restore all default parameters.

- ▶ Select YES
- ▶ Press OK

6. CANCEL ASSISTANCE SETTING	
Do you want to cancel the assistance setting?	
YES	NO
OK Confirm ◀▶	

13. Network configuration guidelines

The keypad has an intelligent control system based on a built-in module, which receives the signal from the APP.

Before connecting the WLAN, check that your router is switched on and make sure the keypad is connected to the wireless signal.

During wireless network configuration, the Wi-Fi icon on the display flashes to indicate that the network is being connected.

Once the configuration is complete, the Wi-Fi icon stays on.

- ▶ Press MENU
- ▶ Select WLAN SETTING
- ▶ Press OK

MENU	
ASSISTANCE SETTING	
WLAN SETTING	
OK	ENTER 2/2 ▼▲

WLAN SETTING	
WIFI WLAN SETTING	OFF
AP MODE	
RESTORE WLAN SETTING	
OK	Confirm ON/OFF ADJUST

- ▶ Select ON/OFF
- ▶ Press to confirm

13.1 Setting the keypad

The keypad settings include AP MODE and RESTORE WLAN SETTING.

Activate the WLAN using the interface.

- ▶ Press MENU
- ▶ Select WLAN SETTING
- ▶ Press OK
- ▶ Select AP MODE
- ▶ Press OK

WLAN SETTING	
WIFI WLAN SETTING	OFF
AP MODE	
RESTORE WLAN SETTING	
OK	ENTER ▼▲

AP MODE	
Do you want to activate the WLAN network and exit?	
NO	YES
OK	Confirm ◀▶

- ▶ Press Left, Right to select YES.
- ▶ Press OK

AP MODE confirmed.

Select AP MODE on the mobile device and continue with the configuration settings following the APP instructions.

⚠ After entering AP MODE, if the mobile phone is not connected, the Wi-Fi icon on the display will flash for 10 minutes, then disappear.

⚠ If it is connected to the mobile phone, the Wi-Fi icon will remain displayed.

13.2 Restore WLAN settings using the interface.

- ▶ Press MENU
- ▶ Select WLAN SETTING
- ▶ Press OK
- ▶ Select RESTORE WLAN SETTING
- ▶ Press OK

WLAN SETTING	
WIFI WLAN SETTING	OFF
AP MODE	
RESTORE WLAN SETTING	
OK	ENTER ▼▲

RESTORE WLAN SETTING	
Do you want to restore the WLAN setting and exit?	
NO	YES
OK	Confirm ◀▶

- ▶ Press Left, Right to select YES.
- ▶ Press OK

The WLAN settings are restored.

Complete the above operation and the wireless configuration is restored.

14. Mobile device setting

AP MODE is available for configuring the wireless network on a mobile phone.

AP MODE WLAN connection:

Install the APP

Scan the following QR code to install the Smart Home APP

Search on the APP STORE or GOOGLE PLAY for “Msmartlife” to install the APP.



Wait for the device to connect and then press “Finish”

14.1 Open and sign up

Press the ‘+’ button on the right side of the home page to register the account and follow the instructions.

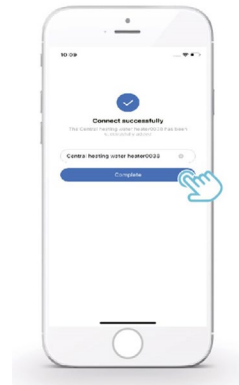
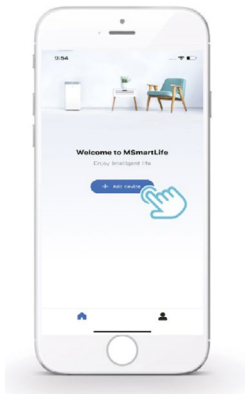

After the appliance has been successfully connected, the Wi-Fi icon on the keypad interface will remain on and the unit can be controlled through the APP.

14.2 Add device

Choose the “Fresh air” model, then add the device.

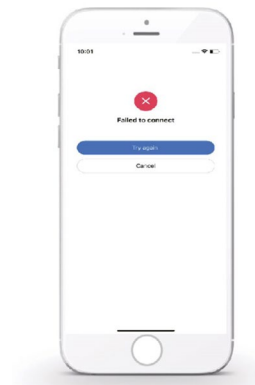

Configure the keypad following the APP instructions.

If the network configuration fails or the mobile connection requires reconnection, use the RESTORE WLAN SETTING on the keypad, then repeat the procedure.

- ⚠ Warnings and troubleshooting for connection errors
- ⚠ When the device is connected to the network, make sure the phone is as close as possible to the device
- ⚠ Only supports routers with 2.4 GHz bandwidth.
- ⚠ Special characters (punctuation, spaces, etc.) Not to be used for the WLAN network name.
- ⚠ It is recommended not to connect more than 10 devices to a single router to avoid weak or unstable network signals.
- ⚠ If the router or WLAN password is changed, delete all settings and reset the device.
- ⚠ The contents of the APP may change as a result of version updates, in which case it will be based on actual operation.

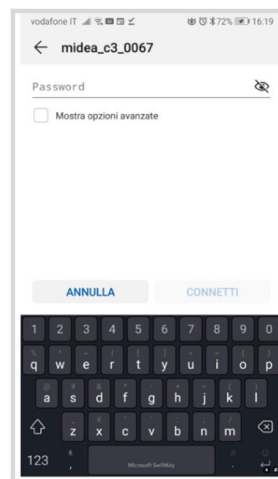

14.3 Access to Wi-Fi network from mobile phone

Select the Wi-Fi network similar to midea-xx-xxxx



Enter password: 12345678

14.4 APP functions



Unit on / off



Mode change:

- Cool
- Heat
- AutoSet
- Auto
- Fan

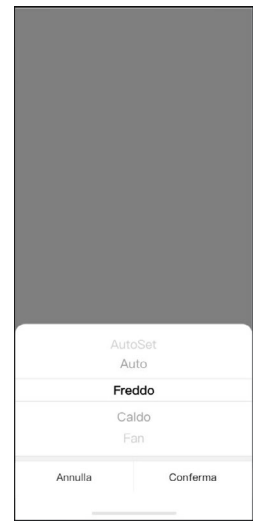
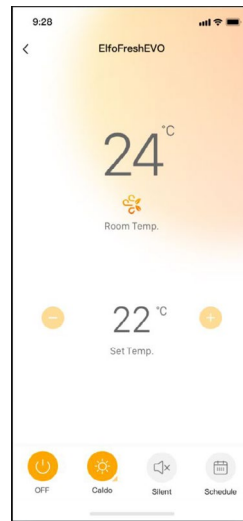

14.5 Silent and Super Silent mode



Press

Select mode:

- Normal silent
- Super silent

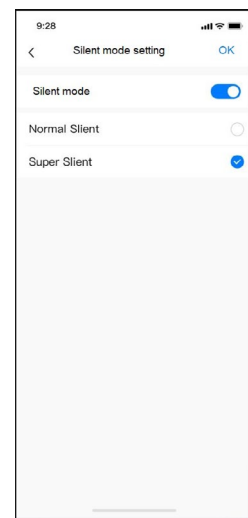
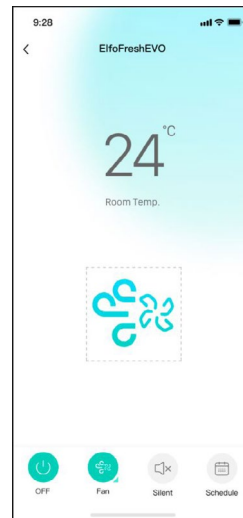

14.6 Scheduling



Press

Select:

- Daily timer
- Weekly

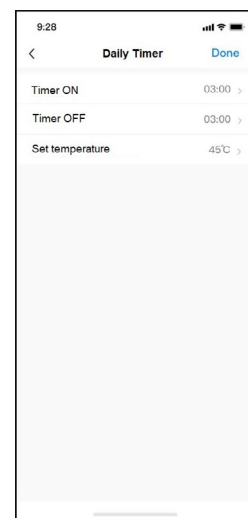
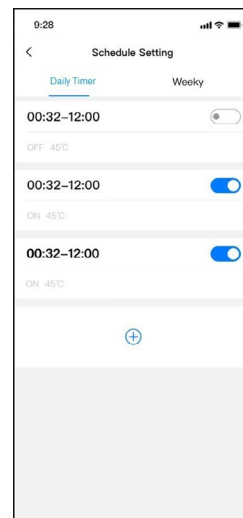

14.7 Scheduling

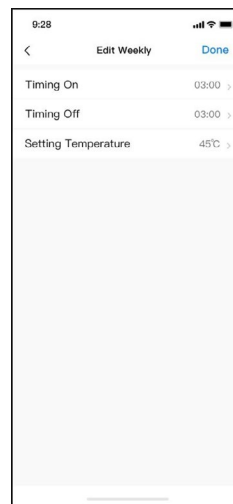
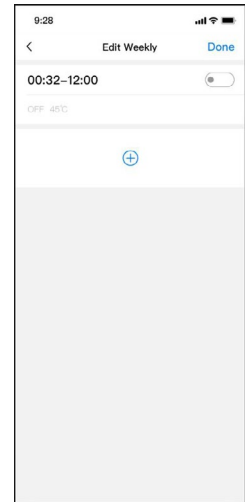
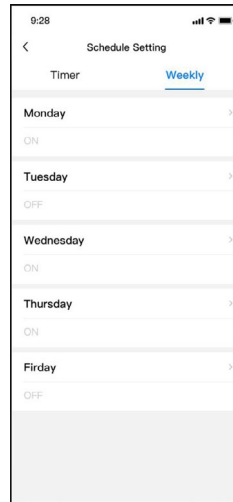

Weekly



15. Alarms

In the event of malfunctions, alarms are indicated by the appearance of the “Active alarm” symbol on the keypad.

To display an alarm, select the ERROR RECORD menu

-  To reset an alarm, remove the cause of the alarm and reset the active alarm.
-  Before resetting an alarm identify and remove the cause that generate it.
-  Repeated reset can cause irreversible damages as maloperation of the system itself.

In case of doubt please contact an Assistance Centre.

Code	Description	
E0	Flashing/EEPROM hardware communication error	C
E1	Communication error between mainboard and HMI	C
E2	T2 sensor failure (refrigerant circuit)	B
E3	Tc sensor failure (supply air temperature)	C
E4	T3 sensor failure (refrigerant circuit)	B
E5	T1 sensor failure (room return air temperature)	B
E6	T4 sensor failure (ambient temperature)	B
E7	Condensate water level switch failure	B
E8	IPM EEPROM fault	B
E9	T2B sensor failure (refrigerant circuit)	B
E15	Return humidity sensor failure	A
E17	CO2/VOC sensor failure	A
EA	Tp sensor failure (refrigerant circuit)	B
Eb	EEV connection error	B
EE	IPM module EEPROM fault	B
EF	PFC module ON/OFF status fault (inverter power factor correction active)	B
EU	Supply airflow humidity sensor failure	A
P0	Tp high temperature protection	B
P1	High pressure switch intervention	B
P2	Low pressure switch intervention	B
P4	Intervention against high unit current limits	B
P5	T3 high temperature protection	B
P7	T2 high temperature protection	B
P9	Supply fan failure	C
PA	Unit exhaust fan failure	C
PL	Tf high temperature protection (compressor inverter)	B
PP	Insufficient refrigerant circuit overheating protection	B
H0	IPM module communication error	B

Code	Description	
H1	Low voltage protection	C
H2	Oversvoltage protection	C
H4	IPM module protections occurred 3 times in 60 minutes	B
H5	P2 error occurred 3 times in 60 minutes	B
H9	Supply fan failure P9 protections occurred 3 times in 60 minutes	C
HA	Exhaust fan failure PA protections occurred 3 times in 60 minutes	C
C1	T1 temperature protection in cooling mode (out of operating range)	B
C2	T1 temperature protection in heating mode (out of operating range)	B
C3	Dirty air filter alarm	A
C4	Tc high temperature protection	B
C5	Tc low temperature protection	B
C6	T4 high temperature protection	C
C7	T4 low temperature protection	C
CB	Reverse installation of Tc sensor and T4 sensor	B
CC	Electrostatic filter failure	A
L0	Compressor driver failure	B
L1	IPM module low voltage protection	B
L2	IPM module high voltage protection	B
L4	MCE fault	B
L5	Fan speed protection	B
L7	IPM module phase loss protection	B
L8	Frequency variations above 15Hz (compressor)	B
L9	The frequency difference is 15Hz (compressor)	B
LA	Compressor overcurrent/overload protection	B
LC	Compressor current sampling circuit fault	B
LH	Compressor start-up failure	B

Code A indicates the presence of an abnormal situation that does not affect the unit's operation.

Code B indicates that the unit's compressor has stopped.

Code C indicates the unit's total shutdown.

16. Unit parameters

Installer use

 Access to parameters or modifications are only allowed to the installer who takes full responsibility, in case of doubt contact Clivet.

 For any changes not permitted or not approved by Clivet, Clivet declines any responsibility for malfunctions and/or damage to the unit/system.

Code		Description	Default	Min	Max	Control	
1.01	AUTOText0	Automatic temperature setting Set point 0 X axis	15	0	50	1	°C
1.02	AUTOText1	Automatic temperature setting Set point 1 X axis, AUTOText1 > AUTOText0+2	24	0	50	1	°C
1.03	AUTOSet0	Automatic temperature setting Set point 0 Y axis	19	17	30	1	°C
1.04	AUTOSet1	Automatic temperature setting Set point 1 Y axis AUTOSet1 > AUTOSet0+2	25	17	30	1	°C
1.05	EnOnOff	Unit switching mode 0 = Remote ON/OFF digital input OFF (closed), ON (open) 1 = HMI	1	0	1	1	-
1.06	EnMode	Setting the mode 0 = Remote ON/OFF digital input OFF (closed Heat or Cool), ON (open Cool or Heat) 1 = HMI	1	0	1	1	-
1.07	DeadZone	Mode switching hysteresis with auto mode change	2	1	10	1	°C
1.08	SupFanSet	Supply fan speed setpoint settings	6	3	7	1	
1.09	SupFanSet2	Second supply fan speed setpoint settings	6	3	7	1	
1.1 0	OffsetT 1	Return air temperature correction	0	-10	10	1	°C
1.11	PoweroffMem	Switch-off memory function 1 = yes 0 = no	1	0	1		
1.12	BMS Add Set	BMS address setting	1	1	16	1	
1.1 3	EnFilter	Electrostatic filter enabling 0 = disabled 1 = enabled	0	0	1		

Code		Description	Default	Min	Max	Control	
1.14	EnHumidifier	Humidifier enabling 0 = disabled 1 = enabled	0	0	1		
2.01	EnProbeUrS u p	Supply airflow humidity sensor enabling	1	0	1	1	-
2.02	OffsetUrS u p	Supply airflow humidity sensor correction	0	-50	50	1	%
2.03	DehumConModeSet	Dehumidification mode setting: 0 = standard humidity 1 = low humidity (high dehumidification request) 2 = eco mode humidity (low dehumidification request)	0	0	2	1	
2.04	HumCorrFanSpe _	Humidity correction on supply fan speed: 1 = follows the unit logic for speed correction 0 = disables the unit logic for speed correction	1	0	1	1	
2.05	EnProbeUrIn	Indoor humidity sensor enabling?	0	0	1	1	-
2.06	OffsetUrIn	Indoor humidity sensor correction	0	-50	50	1	%
2.07	ENProbeVOC&CO2	CO2/VOC sensor enabling	0	0	1	1	
2.08	OffsetVOC&CO2	CO2/VOC value offset	0	-500	500	10	PPM

17. Modbus communication

17.1 Control4 NGR

Option

i For details, see Control4 NRG instruction manual.

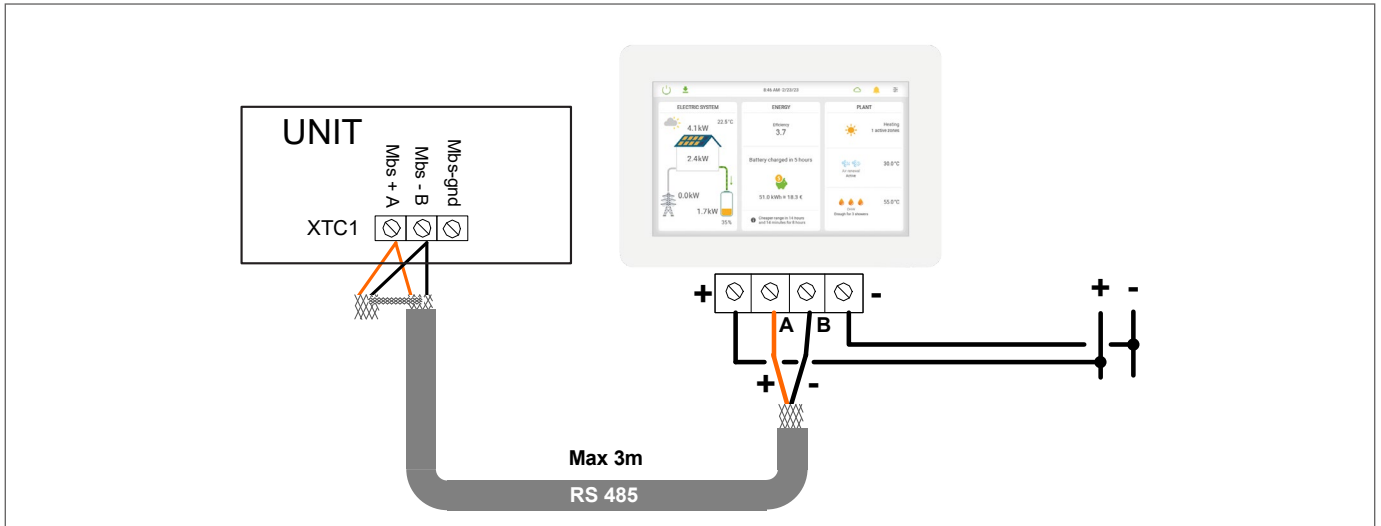

Default settings (cannot be changed)

Modbus connection

Baud rate = 9600

Length = 8

Parity = none

Stop bit = 1

ModBus protocol details: next page

The unit fulfils the essential requirements of product standard EN 55014-1; for wiring lengths of more than 3 m between the unit and the HMI display, it is recommended to route the cable separately and avoid running the communication cable alongside other auxiliary circuits.

For Modbus wiring longer than 3 m between the HMI port and the external BMS, use a twisted and shielded cable, paying particular attention to the grounding of the shielding braid.

17.2 HMI connection

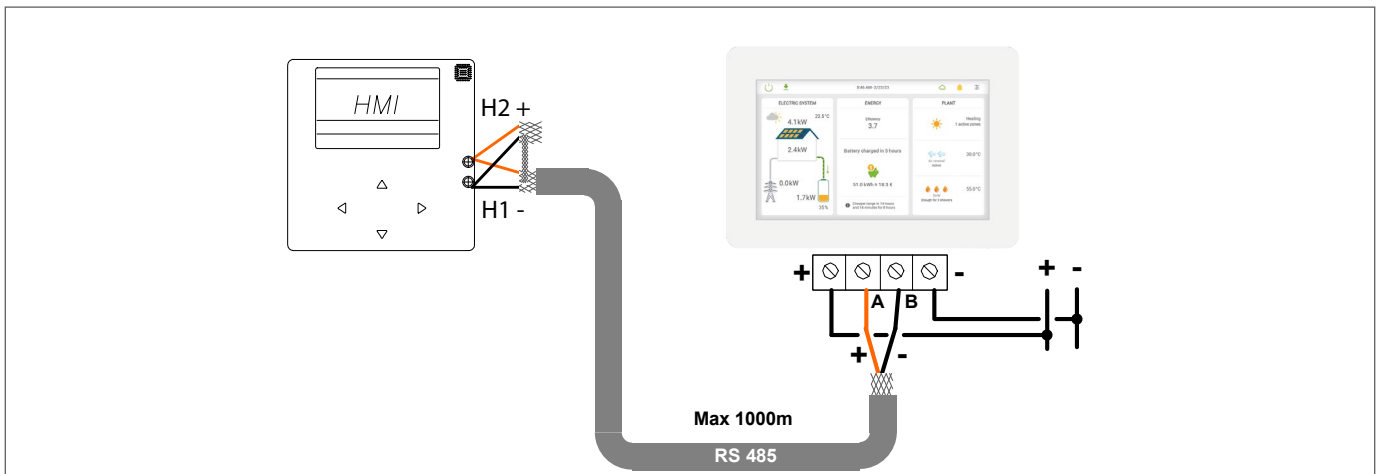

Note

Using the HMI connection disables Modbus control of the dual flow-rate set-point and management of the external CO2+VOC sensor.

! The total laying of the serial line including all components must not exceed 1000m.

17.3 ModBus

* Data in English only

*Operation parameter (writable and readable)		
Register address	Content	Parameter range and its meaning
0	Power on/off	BIT0 0: OFF 1: ON
1	Mode setting	1: Cool 2: Heat 3: Fan 4: Auto
2	T1s Setting temperature	17~28°C
3	Functions setting	BIT0: Silent mode, 0 = disabled, 1= enable
		BIT1: 0 normal silent mode, 1 super silent miode
		BIT2: Auto T1s setting function

*Operation parameter (only readable)		
100	Compressor speed	rps
101	Operation Mode	0: off 1: cool 2: heat 3: fan
102	Supply fan speed	0~9
103	Exhaust fan speed	0~9
104	EXV opening	(0-480) Steps
105	Tc (air sensor)	(-25~70)°C
106	RHC supply air relative humidity	0~100%
107	T3 (refrigerant sensor)	(-25~70)°C
108	T4 (air sensor)	(-25~70)°C
109	TP (refrigerant sensor)	(-25~70)°C
110	TH (refrigerant sensor)	(-25~70)°C
111	T1 (air sensor)	(-25~70)°C
112	T2 (refrigerant sensor)	(-25~70)°C
113	T2B (refrigerant sensor)	ok(-25~70)°C
116	current (total)	A
117	VAC	VAC
118	Compressor running time (second)	Stop or running time, second
119	Current error	

120	History error1	Alarm code, 1-2-3 in different time frames (1 the most recent, 3 the least recent)
121	History error 2	
122	History error 3	
123	Unit size	1: size1; 2: size 2; 3: size 3
124	Operating mode	BIT1 : 1: active; 0: not active BIT2 : 1: active; 0: not active BIT3 : 1: active; 0: not active BIT4 : 1: active; 0: not active BIT8 : 1: active; 0: not active BIT11 : 1: active; 0: not active BIT12 : 1: active; 0: not active
125	Output status	BIT0 : electrical filter (reserved) BIT1 : (reserved) BIT2 : water pump BIT3 : bypass dumper BIT4 : 4-way valve BIT5 : exhaust fan status BIT6 : supply fan status BIT7 : system error BIT8 : unit ON index, BIT9 : (reserved) BIT10 : deforst index
127	Main software version	
128	HMI software version	
129	T1s Setting temperature	°C
130	Module Eprom version (Eeprom code loaded)	
131	Reserved	

18. Maintenance

18.1 Safety

Operate in compliance with safety regulations in force.

To carry out the operations use protection devices:

- gloves, goggles, helmet, headphones, protective knee pads.

All operations must be carried out by personnel trained on possible risks of a general nature, electrical and deriving from operating with equipment under pressure.

Only qualified personnel can operate on the unit, as required by the regulation in force

18.2 General

Maintenance must be performed by authorized centres or by qualified personnel

The maintenance allows to:

- maintaining the unit efficient
- reduce the deterioration speed all the equipment is subject to over time
- collect information and data to understand the efficiency state of the unit and prevent possible faults

Before checking, please verify the following:

- the electrical power supply line should be isolated at the beginning
- the unit isolator is open, locked and equipped with the suitable warning
- make sure no voltage is present

After turning off the power, wait at least 5 minutes before accessing to the electrical panel or any other electrical component.

Before accessing check with a multimeter that there are no residual voltage.

When installing or servicing, never leave the unit unattended after removing the service panels

18.3 Frequency of interventions

Perform an inspection every 6 months.

However, frequency depends on the type of use.

Pan inspections at close intervals in the event of:

- frequent use (continuous or very intermittent use, near the operating limits, etc)
- critical use (service necessary)

Before performing any work, please read carefully: safety warnings for operations on units containing R-32

18.4 Unit booklet

It's advisable to create a unit booklet to take notes of the unit interventions.

In this way it will be easier to adequately note the various interventions and aid any troubleshooting.

Report on the booklet:

- date
- intervention description
- carried out measures etc.

18.5 Standby mode

If a long period of inactivity is foreseen:

- turn off the power
- avoid the risk of frost (use glycol or empty the system)
- Turn off the power to avoid electrical risks or damages by lightning strikes.
- At extremely cold temperatures keep the heaters in the electrical panel turned on (option).

It is recommended to have a qualified technician start the system after a period of inactivity, especially after seasonal stops or for seasonal switch-over.

At start-up, follow the instructions in the “start-up” section.

Schedule technical assistance in advance to prevent mishaps and to be able to use the system when required.

18.6 Structure

The unit's structure is partly made of EPP plastic (expanded polypropylene) and galvanised sheet metal.

It is advisable to clean the EPP plastic structure with products containing no aggressive chemicals.

HBF fire resistance rating.

Galvanised sheet metal structure

Check:

- the condition of the parts making up the structure
- that those parts of the unit subject to oxidation are treated with paints to eliminate or reduce oxidation
- that the unit's external panelling is fixed.

 Poor fastening may give rise to malfunctions and abnormal noise and vibration

18.7 Recommended periodic checks sheet

		intervention frequency (months)		
		1	6	12
1	presence of corrosions			X
2	panel fixing			X
3	outflow test		X	
4	air filters cleaning / inspection	X		
5	air flow rate measurement			X
6	channelling: anti-vibration devices and fastenings check			X
7	check of the fixing and the insulation of the power lead			X
8	check of the earthing cable			X
9	electric panel cleaning			X
10	clamp closure, cable isolation integrity			X
11	power voltage and phase unbalancing (no load and under load)			X
12	absorptions of the single electrical loads		X	
13	checking for leaks *		X	
14	cooling circuit work parameter detection			*
15	control system test: setpoint, capacity steps, airflow variations		X	
16	control device test: alarm signal, probes, etc.		X	
17				

* Refer to the local regulations. Companies and technicians that carry out installation, maintenance/fixing, leak control and recovery interventions must be CERTIFIED as required by local regulations

18.8 Air filters

It is very important for the air treatment coil to offer maximum thermal exchange: the unit must always work with clean and installed filters. Cleaning and replacement of filters are very important from an hygienic-sanitary point of view.

It is very important for the air treatment coil to offer maximum thermal exchange: the unit must always work with clean and installed filters. Cleaning and replacement of filters are very important from an hygienic-sanitary point of view.

Operation with clogged filters leads to a reduction in the air flow rate with malfunctionings and block, up to possible breaks in the unit.

The frequency with which the filters must be checked depends on the quality of the outdoor air, the unit operation hours, the dustiness and crowding of rooms.

Frequency can indicatively vary from WEEKLY to MONTHLY. It is advised to start with frequent checks, subsequently adjusting frequency to degree of detected dirt.

⊘ Do not wash the filters, washing can compromise their functionality.

⚠ Old filters must be disposed of according to the current standards.

⚠ The filter must be replaced after 2500 hours of operation when alarm C3 is displayed.

Timer reset = Select FUNCTION SETTING

- ▶ Press OK
- ▶ Select FILTER CLEANING SET,
- ▶ Press OK
- ▶ Select RECLOCK
- ▶ Press OK

Filter extraction from underneath

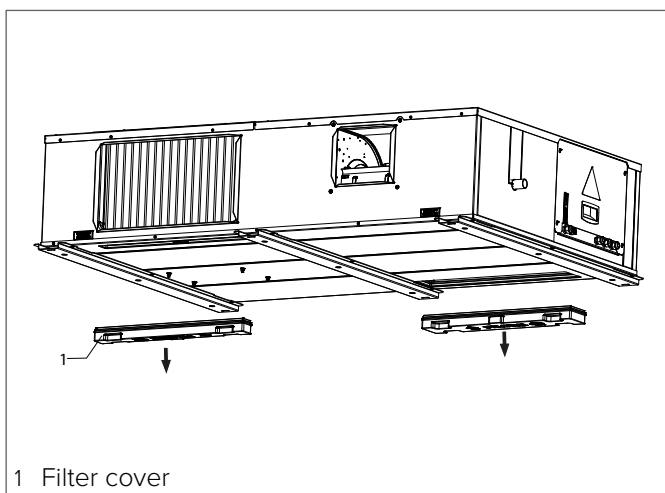

- Remove the filter cover

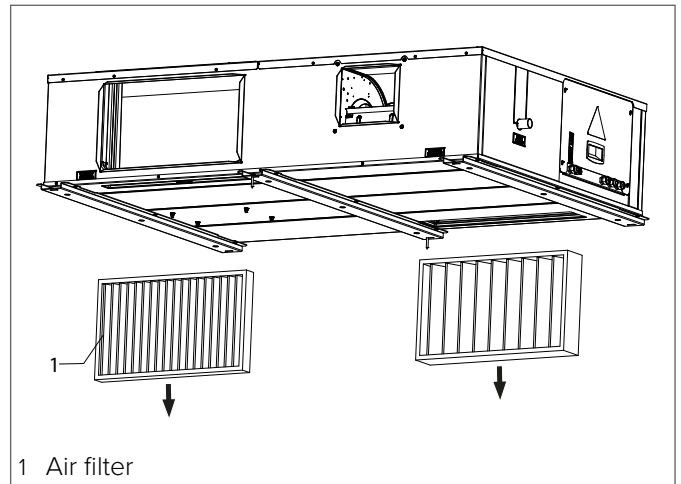

- Delicately remove the filter avoiding dirtying the area below
- Check the condition, if necessary proceed with the replacement

Filter extraction from the top

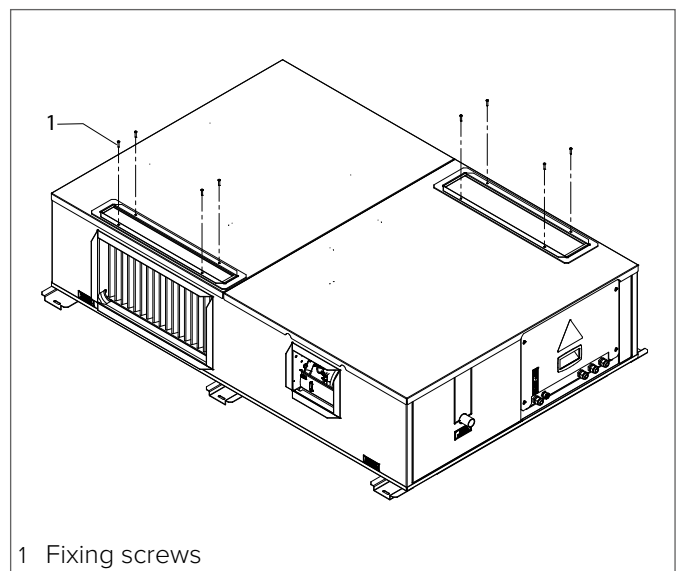

- Remove the fixing screws

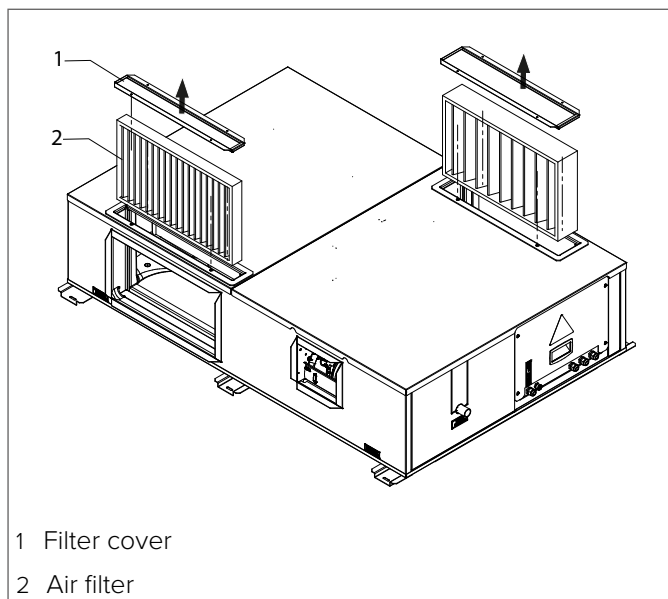

1 Filter cover
2 Air filter

- Remove the filter cover
- Delicately remove the filter avoiding dirtying the area below

To clean:

- wash in warm water with common detergent
- rinse thoroughly under running water, avoiding spillage into the ambient
- dry

Alternatively:

- use blowing or suction

18.9 Electrostatic filter

The filter checking frequency depends on the outdoor air quality.

As a guideline, the optimal frequency can vary from every six months to quarterly.

It is advised to start with frequent checks, subsequently adjusting the frequency to the degree of dirtying.

The most common polluting agents for which the filter is designed are: PM10, PM 2.5 and PM1 air pollution.

Contaminants that can be filtered:

- dry smokes
- powder (up to 0,3 microns)
- smoke electrostatically charged

⊖ Polluting agents that CANNOT be filtered:

- water vapors also in low concentration
- oil vapors
- large amounts of dust
- metal shavings, iron filing dusts and waste generally
- Gas

⊖ To be strictly avoided:

- metal dusts also fine
- fumes produced by combustion of organic and non-organic materials (wood, coal, petrol, etc.)

⚠ Disconnect voltage to the unit

Filter extraction from the top

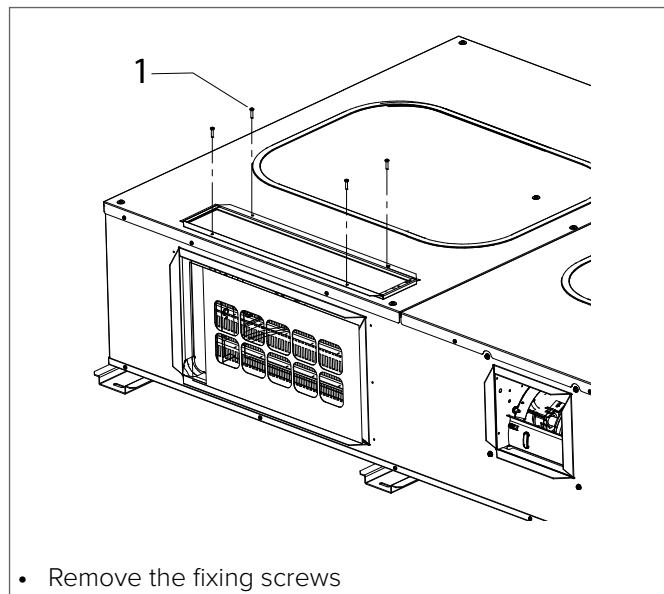

- Remove the fixing screws

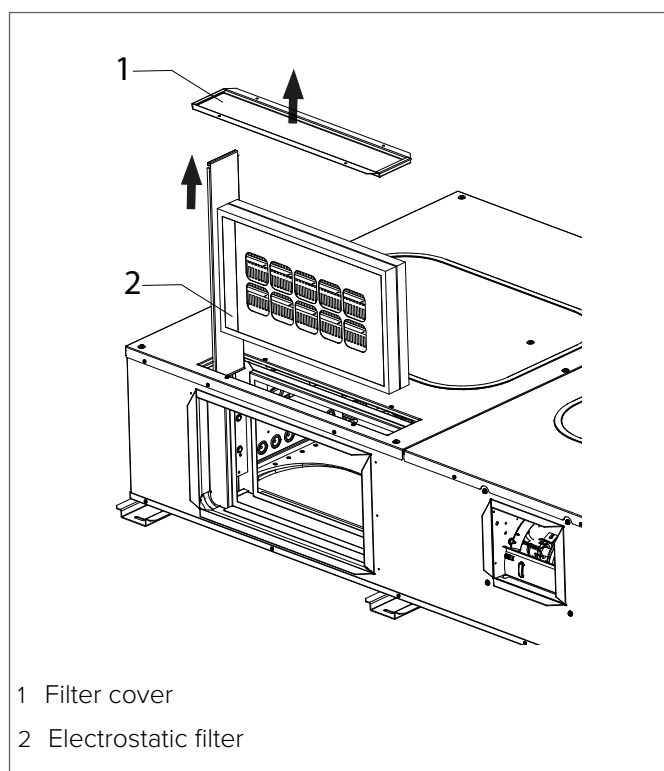

1 Filter cover
2 Electrostatic filter

Filter extraction from underneath

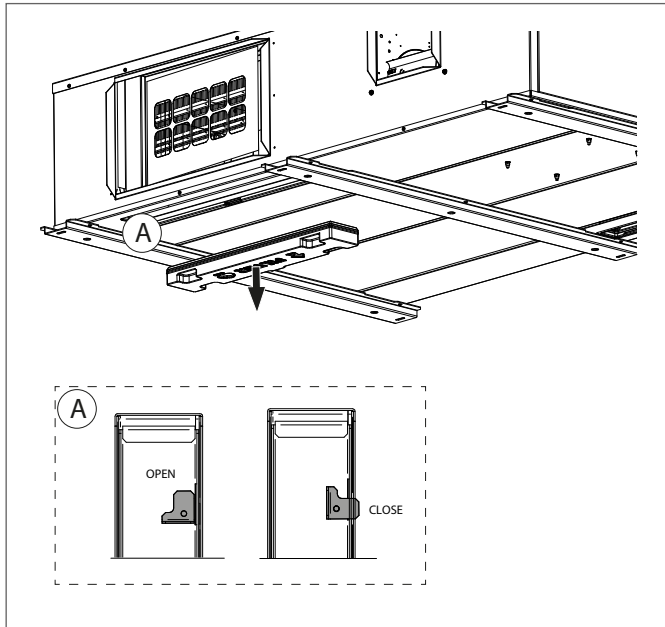

- Remove the filter cover

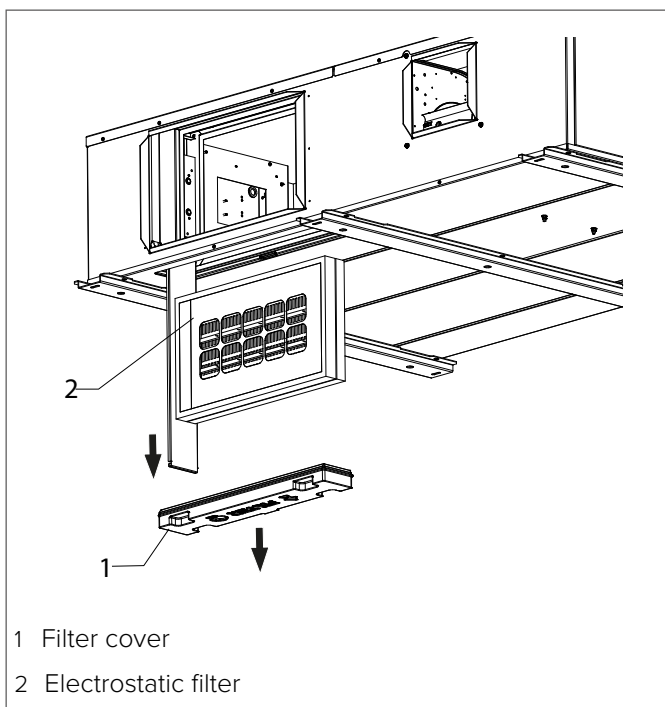

- 1 Filter cover
- 2 Electrostatic filter

Size

	Length	Height	Width
Size 1	580	245	98
Size 2	580	345	98
Size 3	580	525	98

Electrostatic filter cleaning

Position the filter to be washed on a support to facilitate work.

To wash the filter:

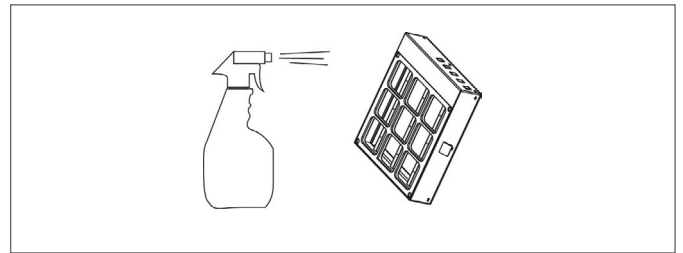

- Spray neutral detergent + water on the filter and leave for 15 minutes

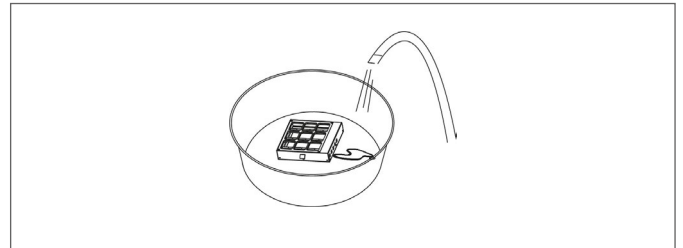

- Immerse the filter in water for no more than 3 to 5 minutes

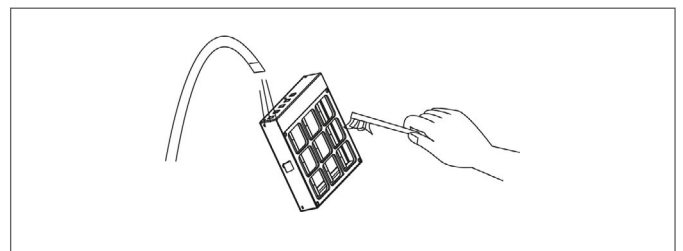

- Rinse the filter with water and at the same time clean with a soft brush

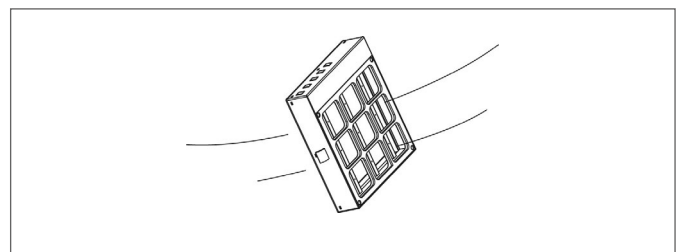

- Dry in a well-ventilated place

⚠ If a detergent is used to clean the filter, it must be rinsed thoroughly without leaving any residues.

⚠ Do not use water hotter than 50°C

⚠ Do not use air hotter than 50°C (it can damage the filter)

⚠ If the filter is not completely dry after cleaning, its performance will be affected if there is a small amount of water left inside.

⚠ Always dry it thoroughly before installation and use.

i The filter may not return to its original colour after cleaning. This is normal and does not affect the filter's performance.

18.10 Aeraulic system cleaning/sanitisation

i The aeraulic system must be cleaned by a specialised technician trained in the field of aeraulic hygiene (in accordance with technical regulations and current national/local regulations).

⚠ The aeraulic system must be inspected periodically to check the condition of the ducts.

If there is a build-up of dirt, contact a specialised technician for cleaning.

Cleaning is carried out using suitable tools (rotary brushes fitted on a flexible cable, vacuum dirt exhauster, etc.), and is done on the supply and return channels.

The channels prone to dust build-ups are the room extraction channels, whereas the room supply channels are less prone to dirtying because there is always air filtration.

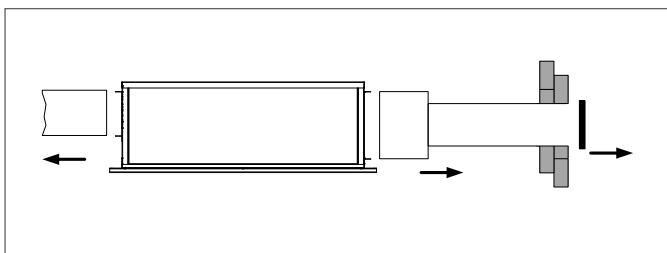

- Disconnect the channels from the unit
- Remove the grille

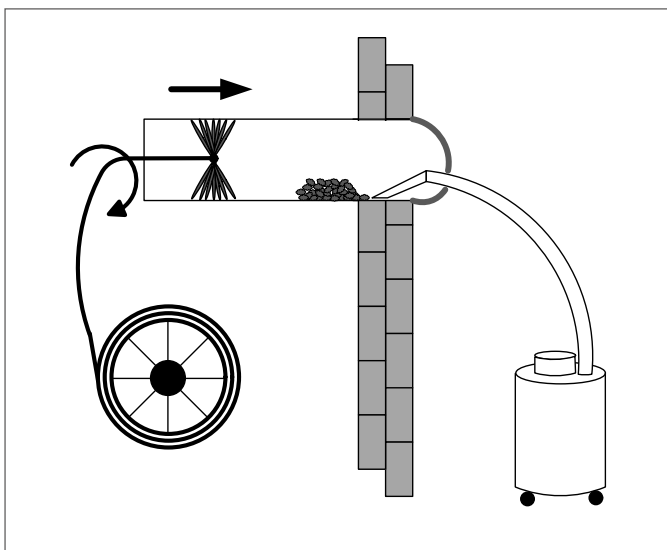

Clean the channels:

- use a suitable vacuum dirt exhauster, cover the inlet.

Periodic maintenance

⚠ Only qualified personnel can operate on the unit, as required by the regulation in force

19. Decommissioning

19.1 Disconnection

⚠ Before performing any work, carefully read: **SAFETY WARNINGS FOR OPERATIONS ON UNITS CONTAINING R-32**

⚠ Avoid leak or spills into the environment.

⚠ Before disconnecting the unit, the following must be recovered, if present:

- refrigerant gas
- Anti-freeze solutions in the hydraulic circuit

⚠ Awaiting decommissioning and disposal, the unit can also be stored outdoors, as bad weather and rapid changes in temperature do not harm the environment provided that the electric, cooling and hydraulic circuits of the unit are intact and closed.

19.2 WEEE INFORMATION

The manufacturer is registered on the EEE National Register, in compliance with implementation of Directive 2012/19/EU and relevant national regulations on waste electrical and electronic equipment.

This Directive requires electrical and electronic equipment to be disposed of properly.

Equipment bearing the crossed-out wheelee bin mark must be disposed of separately at the end of its life cycle to prevent damage to human health and to the environment.

Electrical and electronic equipment must be disposed of together with all of its parts.

To dispose of “household” electrical and electronic equipment, the manufacturer recommends you contact an authorised dealer or an authorised ecological area.

“Professional” electrical and electronic equipment must be disposed of by authorised personnel through established waste disposal authorities around the country.

In this regard, here is the definition of household WEEE and professional WEEE:

WEEE from private households: WEEE originating from private households and WEEE which comes from commercial, industrial, institutional and other sources which, because of its nature and quantity, is similar to that from private households. Subject to the nature and quantity, where the waste from EEE was likely to have been by both a private household and users of other than private households, it will be classed as private household WEEE;

Professional WEEE: all WEEE which comes from users other than private households.

This equipment may contain:

refrigerant gas, the entire contents of which must be recovered in suitable containers by specialised personnel with the necessary qualifications;

lubrication oil contained in compressors and in the cooling circuit to be collected;

mixtures with antifreeze in the water circuit, the contents of which are to be collected;

mechanical and electrical parts to be separated and disposed of as authorised.

When machine components to be replaced for maintenance purposes are removed or when the entire unit reaches the end of its life and needs to be removed from the installation, waste should be separated by its nature and disposed of by authorised personnel at existing collection centres.



20. Residual risks

20.1 General

In this section the most common situations are indicated, as these cannot be controlled by the manufacturer and could be a source of risk situations for people or things.

20.2 Danger zone

This is an area in which only an authorised operator may work.

The danger zone is the area inside the unit which is accessible only with the deliberate removal of protections or parts thereof.

20.3 Handling

The handling operations, if implemented without all of the protection necessary and without due caution, may cause the drop or the tipping of the unit with the consequent damage, even serious, to persons, things or the unit itself.

Handle the unit following the instructions provided in the present manual regarding the packaging and in compliance with the local regulations in force.

Should the refrigerant leak please refer to the refrigerant "Safety sheet".

20.4 Installation

The incorrect installation of the unit could cause water leaks, condensate accumulation, leaking of the refrigerant, electric shock, poor operation or damage to the unit itself.

Check that the installation has been implemented by qualified technical personnel only and that the instructions contained in the present manual and the local regulations in force have been adhered to.

The installation of the unit in a place where even infrequent leaks of inflammable gas and the accumulation of this gas in the area surrounding the area occur could cause explosions or fires.

Carefully check the positioning of the unit.

The installation of the unit in a place unsuited to support its weight and/or guarantee adequate anchorage may result in consequent damage to things, people or the unit itself.

Carefully check the positioning and the anchoring of the unit.

Install the unit in areas which are only accessible to authorised person and/or provide protection against intrusion into the danger zone.

20.5 General risks

Smell of burning, smoke or other signals of serious anomalies may indicate a situation which could cause damage to people, things or the unit itself.

Electrically isolate the unit (yellow-red isolator).

Contact the authorised service centre to identify and resolve the problem at the source of the anomaly.

Accidental contact with exchange batteries, compressors, air delivery tubes or other components may cause injuries and/or burns.

Always wear suitable clothing including protective gloves to work inside the danger zone.

Maintenance and repair operations carried out by non-qualified personnel may cause damage to persons, things or the unit itself.

Always contact the qualified assistance centre.

Failing to close the unit panels or failure to check the correct tightening of all of the panelling fixing screws may cause damage to persons, things or the unit itself.

Periodically check that all of the panels are correctly closed and fixed.

If there is a fire the temperature of the refrigerant could reach values that increase the pressure to beyond the safety valve with the consequent possible projection of the refrigerant itself or explosion of the circuit parts that remain isolated by the closure of the tap.

Do not remain in the vicinity of the safety valve and never leave the refrigerating system taps closed.

20.6 Electric parts

An incomplete attachment line to the electric network or with incorrectly sized cables and/or unsuitable protective devices can cause electric shocks, intoxication, damage to the unit or fires.

Carry out all of the work on the electric system referring to the electric layout and the present manual ensuring the use of a system thereto dedicated.

An incorrect fixing of the electric components cover may lead to the entry of dust, water etc inside and may consequently electric shocks, damage to the unit or fires.

Always fix the unit cover properly.

When the metallic mass of the unit is under voltage and is not correctly connected to the earthing system it may be a source of electric shock and electrocution.

Always pay particular attention to the implementation of the earthing system connections.

Contact with parts under voltage accessible inside the unit after the removal of the guards can cause electric shocks, burns and electrocution.

Open and padlock the general isolator prior to removing the guards and signal work in progress with the appropriate sign.

Contact with parts that could be under voltage due to the start up of the unit may cause electric shocks, burns and electrocution.

When voltage is unnecessary for the circuit open the isolator on the attachment line of the unit itself, padlock it and display the appropriate warning sign.

20.7 Moving parts

Contact with the transmissions or with the fan aspiration can cause injuries.

Prior to entering the inside of the unit open the isolator situated on the connection line of the unit itself, padlock and display the appropriate warning sign.

Contact with the fans can cause injury.

Prior to removing the protective grills or the fans, open the isolator on the attachment line of the unit itself, padlock it and display the appropriate warning sign.

20.8 Refrigerant

The intervention of the safety valve and the consequent expulsion of the gas refrigerant may cause injuries and intoxication.

Always wear suitable clothing including protective gloves and eyeglasses for operations inside the danger zone.

Should the refrigerant leak please refer to the refrigerant "Safety sheet".

Contact between open flames or heat sources with the refrigerant or the heating of the gas circuit under pressure (e.g. during welding operations) may cause explosions or fires.

Do not place any heat source inside the danger zone.

The maintenance or repair interventions which include welding must be carried out with the system off.

20.9 Hydraulic parts

Defects in tubing, the attachments or the removal parts may cause a leak or water projection with the consequent damages to people, things or shortcircuit the unit.

21. Technical information

Performance

SIZE			Size1	Size2	Size3
Nominal conditions					
Nominal Airflow		m ³ /h	500	1000	2000
Cooling					
Cooling capacity	1	kW	1,9	3,6	7,4
Sensible capacity	1	kW	1,9	3,6	7,0
Compressor power input	1	kW	0,2	0,6	0,9
EER_C	1	-	8,41	5,76	8,27
Cooling capacity (EN 14511-2022)	2	kW	1,9	3,5	7,1
EER (EN 14511-2022)	2	-	6,83	4,49	4,17
Heating					
Heating capacity	1	kW	2,3	4,8	9,3
Compressor power input	1	kW	0,3	0,8	1,3
COP_C	1	-	6,99	5,98	7,14
Thermal capacity (EN 14511-2022)	2	kW	2,3	4,6	9,6
COP (EN 14511-2022)	2	-	6,09	5,42	4,68

Performance in cooling mode: room air 27°C D.B./19°C W.B., air entering the outdoor exchanger 35°C D.B./24°C W.B.

Performance in heating mode: room air 20°C D.B./12°C W.B., air entering the outdoor exchanger 7°C D.B./6°C W.B.

1. Supply air temperature 24°C in cooling mode and 20°C in heating mode
2. Data calculated in accordance with EN 14511-2022, with reference to an available pressure of 50 Pa

SIZE			Size1	Size2	Size3
Ventilation Load neutralisation and contribution to room air conditioning					
Nominal Airflow		m ³ /h	500	1000	2000
Cooling					
Cooling capacity	1	kW	4,3	8,5	15,3
Sensible capacity	1	kW	3,0	6,1	10,9
Compressor power input	1	kW	1,2	2,9	3,5
EER_C	1	-	3,55	2,93	4,35
Additional sensible capacity available in the room	1	kW	1,8	3,6	5,8
Heating					
Heating capacity	1	kW	4,1	8,1	16,2
Compressor power input	1	kW	1,2	1,9	2,6
COP_C	1	-	3,6	4,2	6,1
Additional available capacity in the room	1	kW	1,7	3,3	6,6

Performance in cooling mode: room air 27°C D.B./19°C W.B., air entering the outdoor exchanger 35°C D.B./24°C W.B.

Performance in heating mode: room air 20°C D.B./12°C W.B., air entering the outdoor exchanger 7°C D.B./6°C W.B.

Working point attainable during independent thermoregulation of the unit

1. Specific supply humidity 11 g/kg in cooling mode and Supply air temperature 30°C in heating mode

SIZE			Size1	Size2	Size3
Fan					
Nominal Airflow		m ³ /h	500	1000	2000
Supply fan consumption	1	W	35	93	396
Exhaust fan consumption	2	W	36	94	405
SFP (Specific Fan Power)		W/(m ³ /s)	511	673	1442

Contains fluorinated greenhouse gases (GWP 675)

1. Available static supply pressure 50 Pa
2. Available static exhaust pressure 50 Pa

Construction characteristics

SIZE			Size 1	Size 2	Size 3
Compressor					
Refrigerant			R32		
Type of compressors	1	-	ROT		
No. of compressors		Nr	1	1	1
Refrigeration circuits		Nr	1	1	1
Control capacity		%	10-100%	10-100%	10-100%
Refrigerant charge	2	kg	0,6	0,8	1,7
Air Handling Section Fans (Supply)					
Type of supply fan/motor	3	-	CFG/EC	CFG/EC	CFG/EC
No. of supply fans		Nr	1	1	1
Nominal supply airflow		m ³ /h	500	1000	2000
Minimum supply airflow		m ³ /h	300	700	1400
Maximum supply airflow		m ³ /h	720	1500	2500
Installed unit power		kW	0,17	1,0	1,0
Max. static pressure supply fan	4	Pa	250	425	300
Fans (Exhaust)					
Type of fans/motor	3	-	CFG/EC	CFG/EC	CFG/EC
No. of fans		Nr	1	1	1
Installed unit power		kW	0,17	1	1
Maximum exhaust static pressure	4	Pa	215	390	230
Connections					
Condensate drain		mm	32	32	32
Power supply					
Standard power supply		V	230/1~/50	230/1~/50	230/1~/50

1. ROT = Rotary compressor; SCROLL = Scroll compressor
2. Indicative values for standard units with possible +/-10% variation. The actual data are indicated on the label of the unit
3. RAD = radial fan - EC = Electronic Switching
4. Net pressure available at nominal flow-rate

Nominal Flow-Rate

Sound levels – Nominal operation

SIZE	Sound power level								Sound power level	Sound pressure level (1 m)	Supply sound power level	Return sound power level
	Octave band (Hz)											
	63	125	250	500	1000	2000	4000	8000	dB(A)	dB(A)	dB(A)	dB(A)
Size1	40	44	47	53	57	56	50	40	62	50	59	56
Size2	14	33	44	56	63	58	54	44	65	53	64	62
Size3	18	40	52	63	68	66	63	55	72	60	76	74

Silent sound levels

SIZE	Sound power level								Sound power level	Sound pressure level (1 m)
	Octave band (Hz)									
	63	125	250	500	1000	2000	4000	8000	dB(A)	dB(A)
Size1	40	42	45	51	55	54	48	38	60	48
Size2	13	31	42	54	61	56	52	42	63	51
Size3	16	38	50	61	66	64	61	53	70	58

Supersilent sound levels

SIZE	Sound power level								Sound power level	Sound pressure level (1 m)
	Octave band (Hz)									
	63	125	250	500	1000	2000	4000	8000	dB(A)	dB(A)
Size1	38	40	43	49	53	52	46	36	58	46
Size2	13	28	39	51	58	53	49	39	60	48
Size3	11	31	43	54	59	57	54	46	63	51

Capacity and airflow limitations in Silent e Supersilent modes

	Size 1		Size 2		Size 3		
	Silent	Supersilent	Silent	Supersilent	Silent	Supersilent	
Capacity C/H *	-	0,61	0,35	0,71	0,38	0,66	0,37
EER/COP *	-	1,73	1,81	1,29	1,63	1,33	1,88
Airflow	m ³ /h	500**	300	1000**	700	2000**	1400

* Limiting factors to be applied to maximum capacity performance

** If standard working airflow is lower, it will not be increased

Sound levels refer to a unit with nominal load installed in a false ceiling and ducted. Available static pressure 50 Pa

The average sound pressure level, in accordance with UNI-EN ISO 3744, refers to a distance of 1 m from the outer surface of a ducted unit installed in a false ceiling. Power measurements are taken in accordance with UNI EN ISO 9614-2, with a ducted unit installed near a reflective surface, with a tolerance of 2 dB(A) on the measured sound power level.

The SILENT and SUPER SILENT operating modes (selectable via keypad or dry contact) limit the compressor and fan speed in order to reduce the noise level. If the unit is installed under conditions other than the nominal test conditions (e.g., near walls or obstacles in general), sound levels may vary significantly.

Minimum Flow-Rate

Sound levels – Nominal operation

SIZE	Sound power level								Sound power level	Sound pressure level (1 m)
	Octave band (Hz)									
	63	125	250	500	1000	2000	4000	8000	dB(A)	dB(A)
Size1	38	40	43	49	53	52	46	36	58	46
Size2	13	29	40	52	59	54	50	40	60	48
Size3	11	31	43	54	59	57	54	46	63	51

Maximum Flow-Rate

Sound levels – Nominal operation

SIZE	Sound power level								Sound power level	Sound pressure level (1 m)
	Octave band (Hz)									
	63	125	250	500	1000	2000	4000	8000	dB(A)	dB(A)
Size1	46	51	54	60	64	63	57	48	68	56
Size2	20	42	54	65	70	68	65	57	74	62
Size3	21	43	55	66	71	69	66	63	75	63

Sound levels refer to a unit with nominal load installed in a false ceiling and ducted. Available static pressure 50 Pa

The average sound pressure level, in accordance with UNI-EN ISO 3744, refers to a distance of 1 m from the outer surface of a ducted unit installed in a false ceiling

Power measurements are taken in accordance with UNI EN ISO 9614-2, with a ducted unit installed near a reflective surface, with a tolerance of 2 dB(A) on the measured sound power level.

The SILENT and SUPER SILENT operating modes (selectable via keypad or dry contact) limit the compressor and fan speed in order to reduce the noise level

If the unit is installed under conditions other than the nominal test conditions (e.g., near walls or obstacles in general), sound levels may vary significantly

Fields of application

Heating

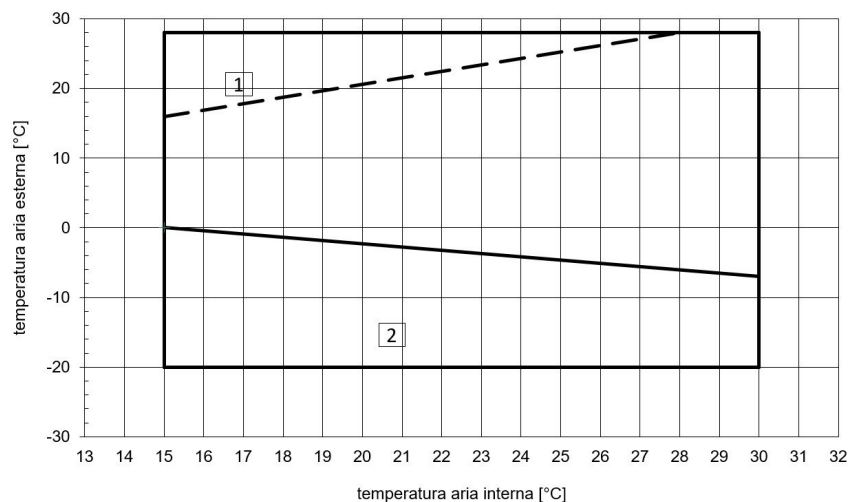

The limits are meant as an indication and they have been calculated by considering:

- nominal airflow
- clean exchangers and filters
- unrestricted positioning of the unit and its correct use
- return air relative humidity > 50%

1. Possible FREE-HEATING operation area
2. Operating range with possible modulation of the supply airflow, in which defrosting cycles could occur

The unit can work in airflow modulation to stay within the operating range

Cooling

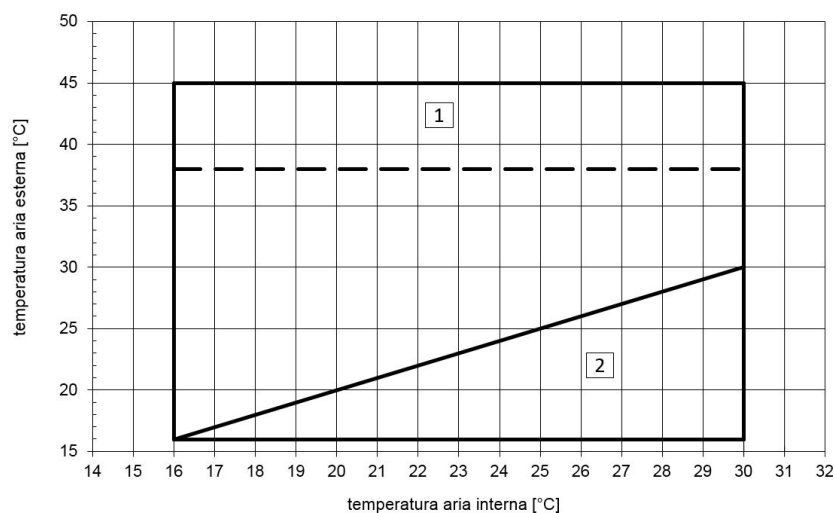

The limits are meant as an indication and they have been calculated by considering:

- nominal airflow
- clean exchangers and filters
- unrestricted positioning of the unit and its correct use

1. Operating range with outdoor relative humidity < 40%
2. Possible FREE-COOLING operation area

The unit can work in airflow modulation to stay within the operating range

22. Dimensional

Size 1

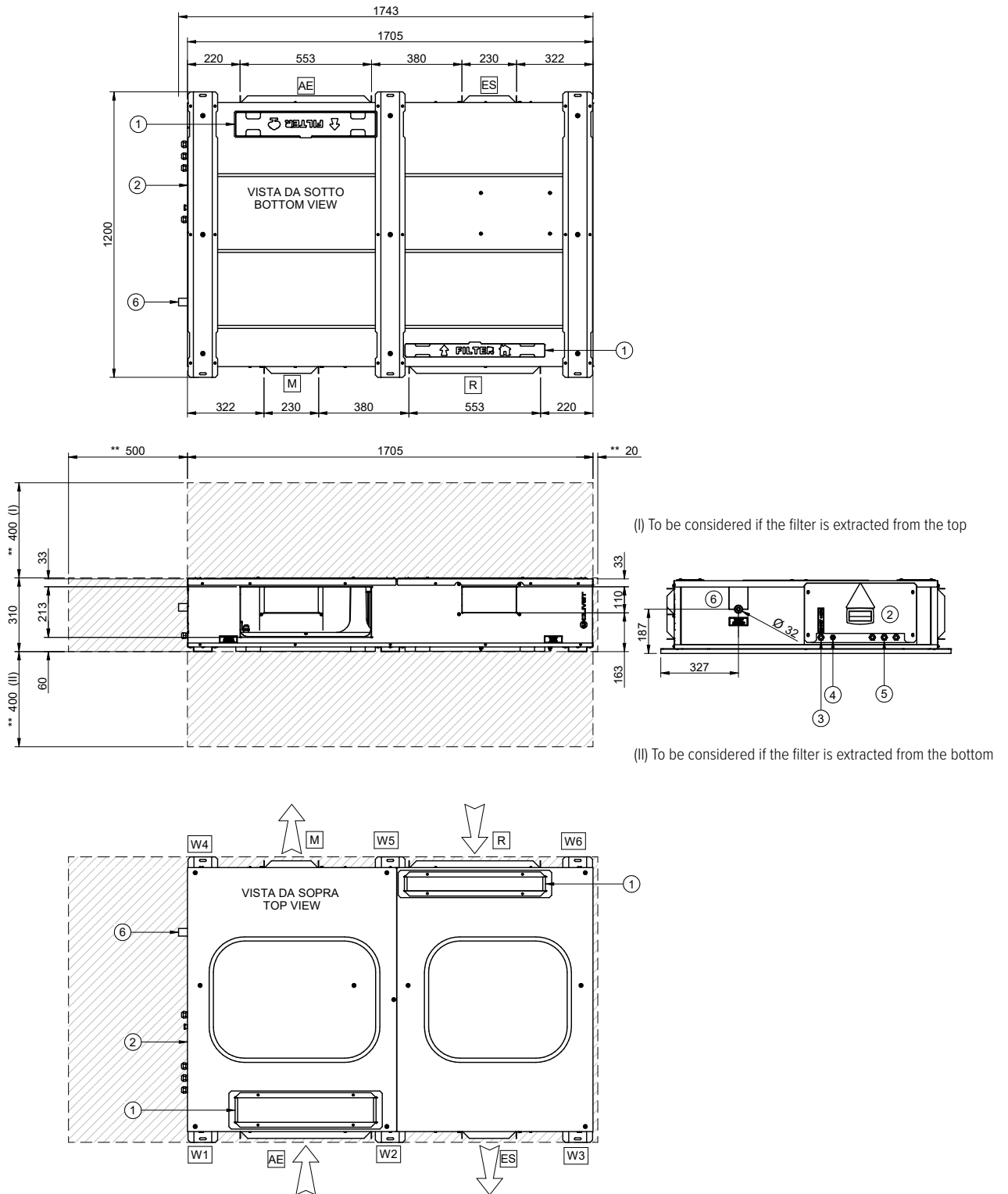

- 1. Removable air filter panel
 - 2. Electrical panel
 - 3. Power input
 - 4. Control keypad connection
 - 5. Auxiliary connection
 - 6. Condensation drain outlet
- W1-W2-W3-W4-W5-W6 = Fixing points
 AE = Outdoor air return
 ES = Air exhaust

- M = Ambient air supply
- R = Ambient air return
- ** Clearances

WEIGHT DISTRIBUTION

SIZE	SIZE 1	
W1 - W2 - W4 - W5	kg	15
W3 - W6	kg	18
Operation weight	kg	96
Shipping weight	kg	118

Size 2

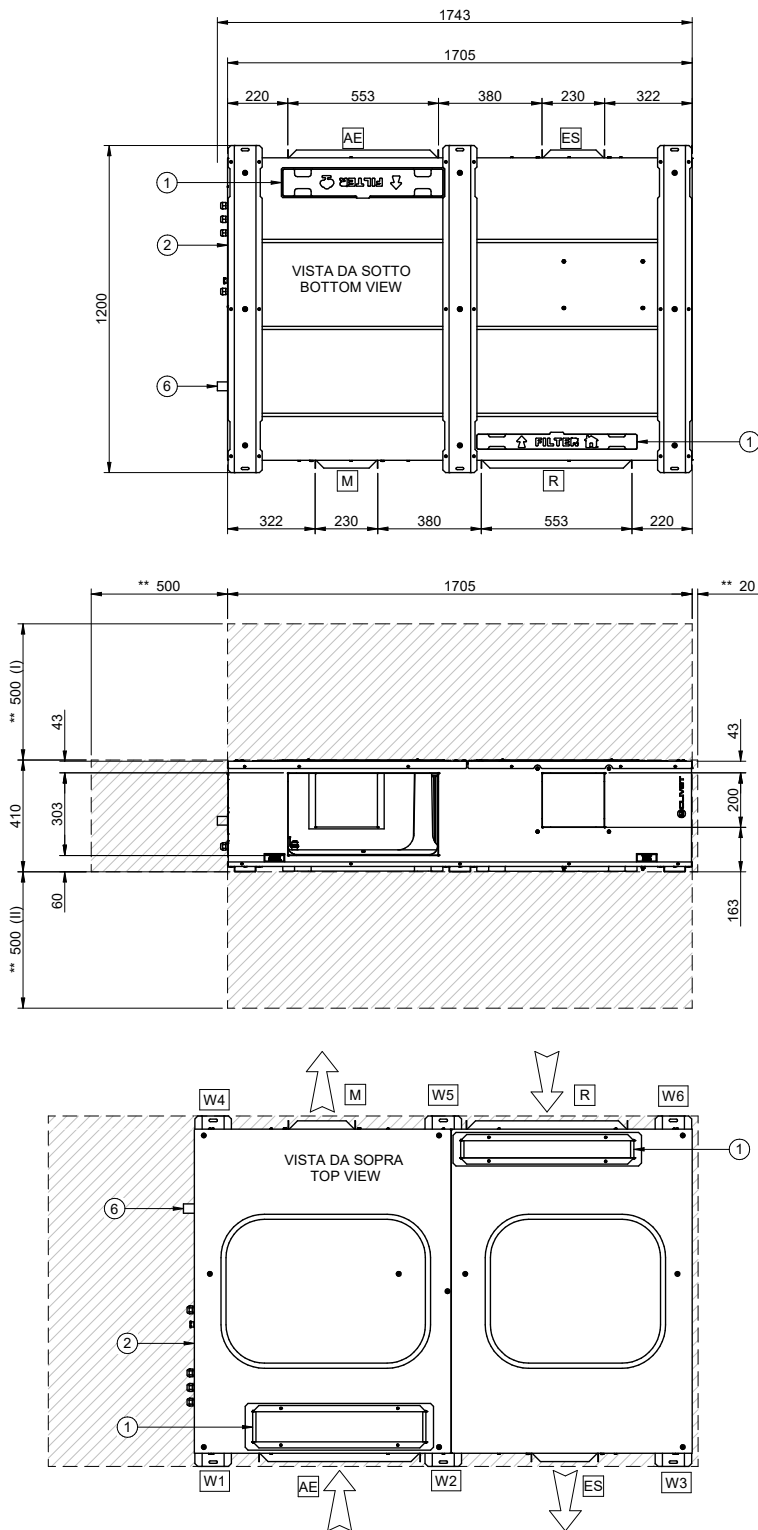

(I) To be considered if the filter is extracted from the top

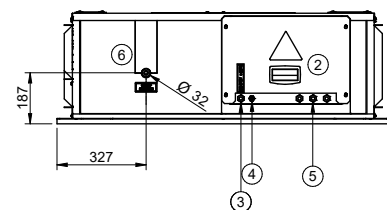

(II) To be considered if the filter is extracted from the bottom

- 1. Removable air filter panel
 - 2. Electrical panel
 - 3. Power input
 - 4. Control keypad connection
 - 5. Auxiliary connection
 - 6. Condensation drain outlet
- W1-W2-W3-W4-W5-W6 = Fixing points
 AE = Outdoor air return
 ES = Air exhaust
 M = Ambient air supply
 R = Ambient air return

** Clearances

WEIGHT DISTRIBUTION

SIZE	SIZE 2	
W1 - W2 - W4 - W5	kg	20
W3 - W6	kg	23
Operation weight	kg	126
Shipping weight	kg	153

Size 3

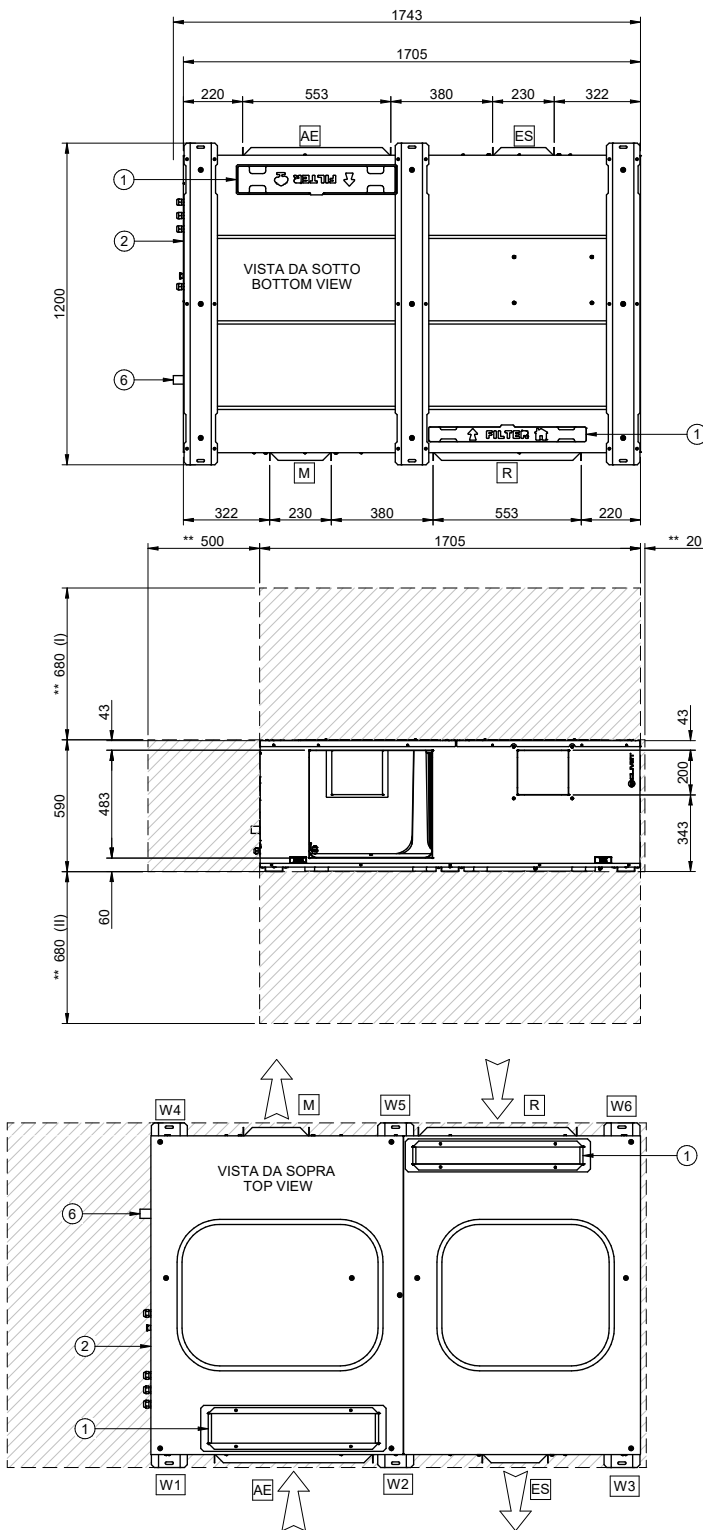

(I) To be considered if the filter is extracted from the top

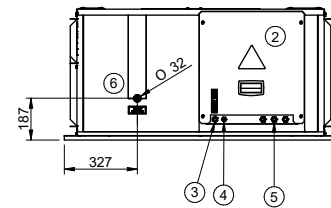

(II) To be considered if the filter is extracted from the bottom

- 1. Removable air filter panel
 - 2. Electrical panel
 - 3. Power input
 - 4. Control keypad connection
 - 5. Auxiliary connection
 - 6. Condensation drain outlet
- W1-W2-W3-W4-W5-W6 = Fixing points
 AE = Outdoor air return
 ES = Air exhaust
 M = Ambient air supply
 R = Ambient air return

** Clearances

WEIGHT DISTRIBUTION

SIZE	SIZE 3	
W1 - W2 - W4 - W5	kg	22
W3 - W6	kg	25
Operation weight	kg	138
Shipping weight	kg	165

FOR OVER 35 YEARS WE HAVE BEEN OFFERING
SOLUTIONS FOR SUSTAINABLE COMFORT
AND THE WELL-BEING OF PEOPLE AND THE
ENVIRONMENT

Info & Contacts: www.clivet.com

