

*Direct expansion
indoor unit for VRF*

1-way cassette

Q1DN-3A-XY D18 - D71



TECHNICAL BULLETIN



SIZE	D18	D22	D28	D36	D45	D56	D71
COOLING CAPACITY kW	1.8	2.2	2.8	3.6	4.5	5.6	7.1
HEATING CAPACITY kW	2.0	2.5	3.2	4.0	5.0	6.3	8.0

General technical data

Model			Q1DN-3-XY D18	Q1DN-3-XY D22	Q1DN-3-XY D28	Q1DN-3-XY D36
Power supply			1-phase, 220-240V, 50Hz			
Cooling ¹	Capacity	kW	1.8	2.2	2.8	3.6
		kBtu/h	6.1	7.5	9.6	12.3
	Power input	W	25	25	30	30
Heating ²	Capacity	kW	2.2	2.6	3.2	4.0
		kBtu/h	7.5	8.9	10.9	13.6
	Power input	W	25	25	30	30
Fan motor type	Type		DC			
	Number		1			
	Number of rows		2	2	2	2
	Tube pitch × row pitch	mm	21×13.37	21×13.37	21×13.37	21×13.37
	Fin spacing	mm	1.5	1.5	1.5	1.5
Indoor coil	Fin type		Hydrophilic aluminum			
	Tube OD and type	mm	Φ7 Inner-groove			
	Dimensions (L×H×W)	mm	760×252.4×26.74			
	Number of circuits		2	2	3	3
Air flow rate ³	m ³ /h	380/355/330/300/286/263/240			460/440/410/380/355/330/300	
Sound pressure level ⁴	dB(A)	30/28/27/26/25/24/22			37/36/35/34/32/31/30	38/37/35/34/32/31/30
Sound power level	dB(A)	44/42/41/40/39/38/36			51/50/49/48/46/45/44	52/51/49/48/46/45/44
Main body	Net dimensions ⁵ (W×H×D)	mm	1054×153×428			
	Net dimensions (no water tray)(W×H×D)	mm	1054×141×428			
	Packed dimensions (W×H×D)	mm	1155×245×490			
	Net/Gross weight	kg	11.5/14.5		11.8/14.8	
Panel	Net dimensions (W×H×D)	mm	1180×25×465			
	Packed dimensions (W×H×D)	mm	1232×107×517			
	Net/Gross weight	kg	3.5/4.7			
Refrigerant type		R410A/R32				
Design pressure (H/L)	MPa	4.4/2.6				
Pipe connections	Liquid/Gas pipe	mm	Φ6.35/Φ12.7			
	Drain pipe	mm	OD Φ25			

Notes:

- Indoor temperature 27°C DB, 19°C WB; outdoor temperature 35°C DB; equivalent refrigerant piping length 7.5m with zero level difference.
- Indoor temperature 20°C DB; outdoor temperature 7°C DB, 6°C WB; equivalent refrigerant piping length 7.5m with zero level difference.
- Air flow rate are from the highest speed to the lowest speed, total 7 rates for each model.
- Sound pressure level is from highest level to lowest level, total 7 levels for each model. Sound pressure level is measured 1.4m below the unit in a anechoic chamber.
- Unit body dimensions given are the largest external dimensions of the unit, including hanger attachments.

General technical data

Model			Q1DN-3-XY D45	Q1DN-3-XY D56	Q1DN-3-XY D71
Power supply			1-phase, 220-240V, 50Hz		
Cooling ¹	Capacity	kW	4.5	5.6	7.1
		kBtu/h	15.4	19.1	24.2
	Power input	W	40	48	60
Heating ²	Capacity	kW	5.0	6.3	8.0
		kBtu/h	17.1	21.5	27.3
	Power input	W	40	48	60
Fan motor type	Type		DC		
	Number		1		
Indoor coil	Number of rows		2	2	2
	Tube pitch × row pitch	mm	21×13.37	21×13.37	21×13.37
	Fin spacing	mm	1.5	1.5	1.5
	Fin type		Hydrophilic aluminum		
	Tube OD and type	mm	Φ7 Inner-groove		
	Dimensions (L×H×W)	mm	955×231×26.74		
	Number of circuits		3	3	5
Air flow rate ³	m ³ /h	693/662/638/600/556/510/476	792/763/728/688/643/589/549	933/873/815/749/689/637/592	
Sound pressure level ⁴	dB(A)	39/37/36/35/34/32/31	41/39/38/37/36/35/33	43/41/40/39/37/36/35	
Sound power level	dB(A)	53/51/50/49/48/46/45	55/53/52/51/50/49/47	57/55/54/53/51/50/49	
Main body	Net dimensions ⁵ (W×H×D)	mm	1275×189×452		
	Net dimensions (no water tray)(W×H×D)	mm	1275×176×452		
	Packed dimensions (W×H×D)	mm	1370×295×505		
	Net/Gross weight	kg	15.8/20.2		
Panel	Net dimensions (W×H×D)	mm	1350×25×505		
	Packed dimensions (W×H×D)	mm	1410×95×560		
	Net/Gross weight	kg	4/5.6		
Refrigerant type		R410A/R32			
Design pressure (H/L)	MPa	4.4/2.6			
Pipe connections	Liquid/Gas pipe	mm	Φ6.35/Φ12.7		Φ9.52/Φ15.9
	Drain pipe	mm	OD Φ25		

Notes:

- Indoor temperature 27°C DB, 19°C WB; outdoor temperature 35°C DB; equivalent refrigerant piping length 7.5m with zero level difference.
- Indoor temperature 20°C DB; outdoor temperature 7°C DB, 6°C WB; equivalent refrigerant piping length 7.5m with zero level difference.
- Air flow rate are from the highest speed to the lowest speed, total 7 rates for each model.
- Sound pressure level is from highest level to lowest level, total 7 levels for each model. Sound pressure level is measured 1.4m below the unit in a anechoic chamber.
- Unit body dimensions given are the largest external dimensions of the unit, including hanger attachments.

Dimensions

Size D18 - D22 - D28 - D36 (unit: mm)

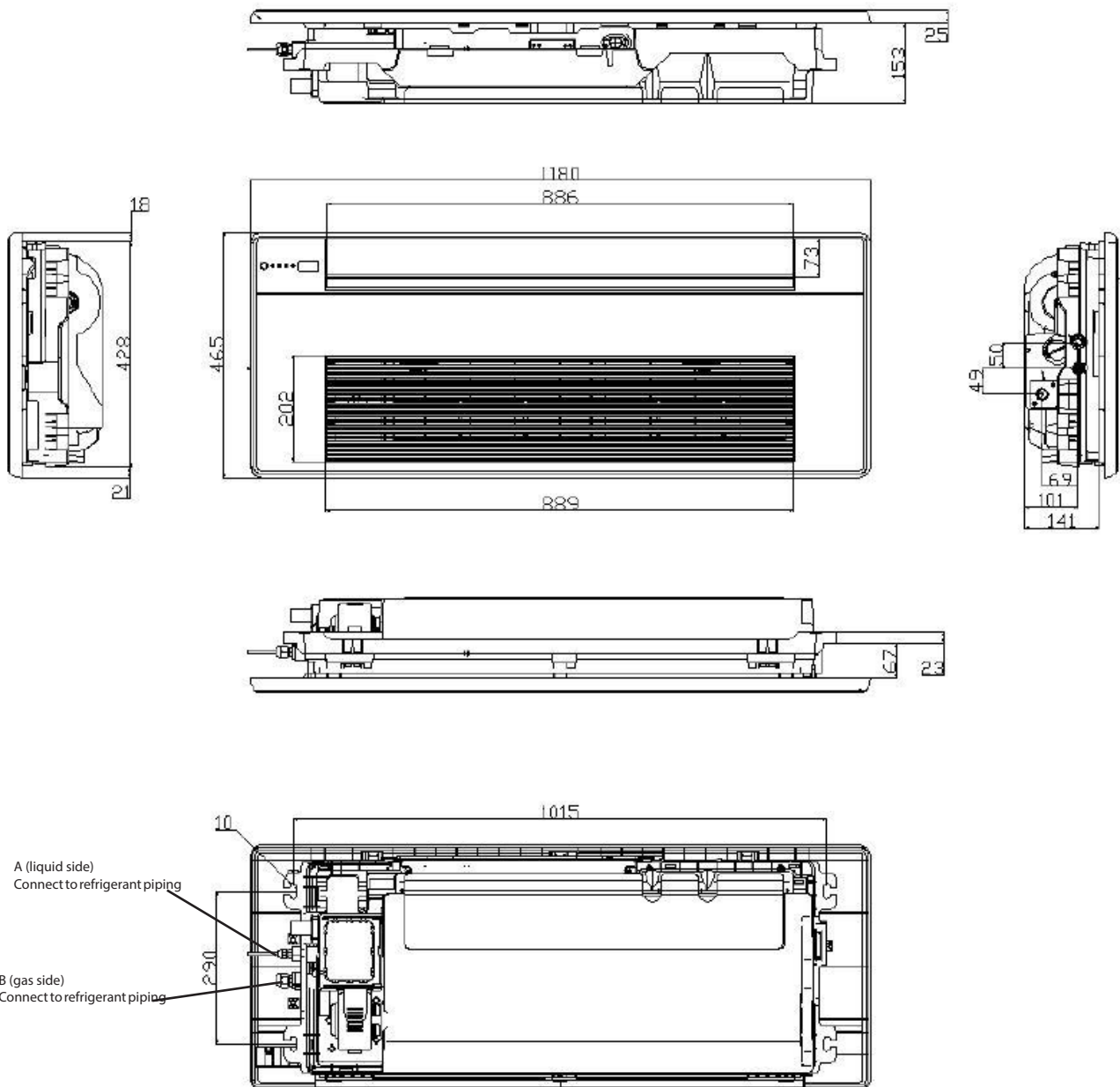

MODEL	A	B
D18-D36	Φ6.35	Φ12.7

Dimensions

Size D45 - D56 - D71 (unit: mm)

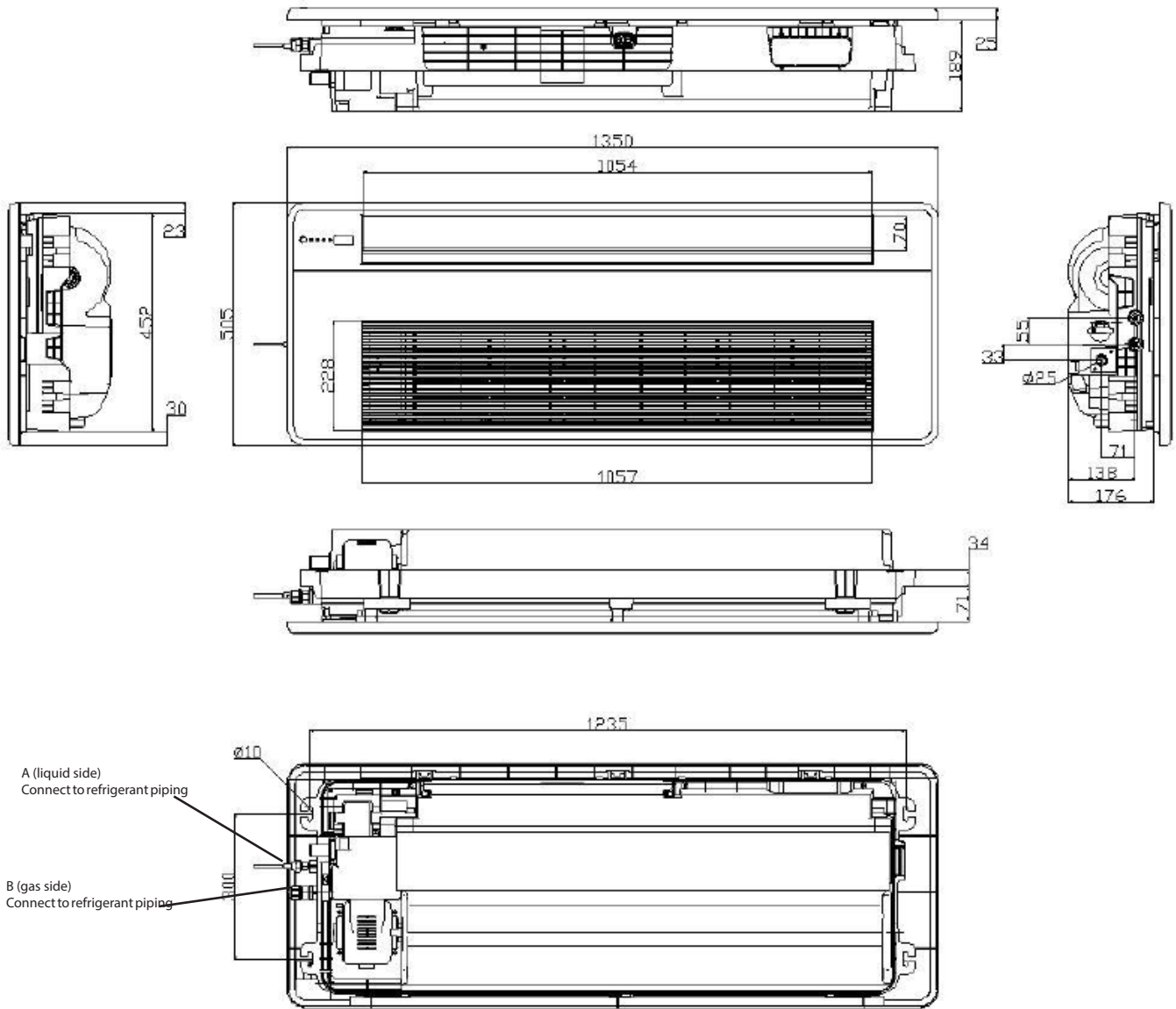

MODEL	A	B
D45÷D56	$\varnothing 6.35$	$\varnothing 12.7$
D71	$\varnothing 9.52$	$\varnothing 15.9$

Placement Considerations

Unit placement should take account of the following considerations:

- Units should not be installed in the following locations:
 - Where exposure to direct radiation from a high-temperature heat source or to interference from a source of electromagnetic radiation may occur.
 - Where dust or dirt may affect heat exchangers.
 - Where exposure to oil or to corrosive or harmful gases, such as acidic or alkaline gases, may occur.
 - Where exposure to salinity may occur, such as seaside locations.
 - Where highly flammable materials are present.
 - Where exposure to oily air may occur, such as a kitchen.
 - Where exposure to very high humidity may occur, such as a laundry.
- Units should be installed in positions where:
 - The ceiling is horizontal and is able to bear the unit's weight.
 - There are no obstructions that could impede the airflow into and out of the unit.
 - The airflow out of the unit can reach throughout the room.
 - There is sufficient space for access during installation, servicing and maintenance.
 - The refrigerant piping and drain piping can be easily connected to the refrigerant piping and

Space Requirements (unit: mm)

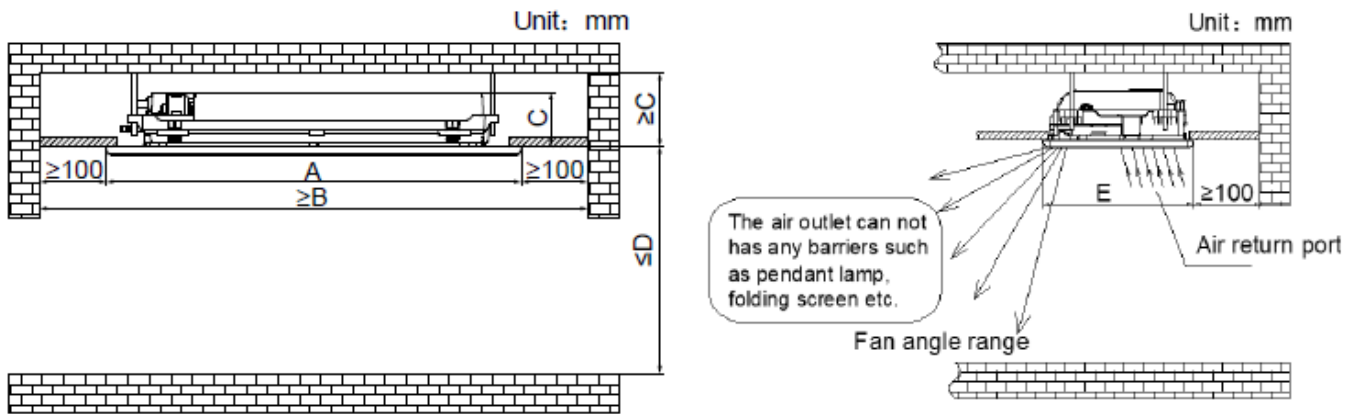

MODEL NAME	Dimensions / Requirements (mm)				
	A	B	C	D	E
Q1DN-3-XY D18					
Q1DN-3-XY D22	1180	1380	153	3200	465
Q1DN-3-XY D28					
Q1DN-3-XY D36					
Q1DN-3-XY D45					
Q1DN-3-XY D56	1350	1550	189	4000	505
Q1DN-3-XY D71					

Piping Diagram

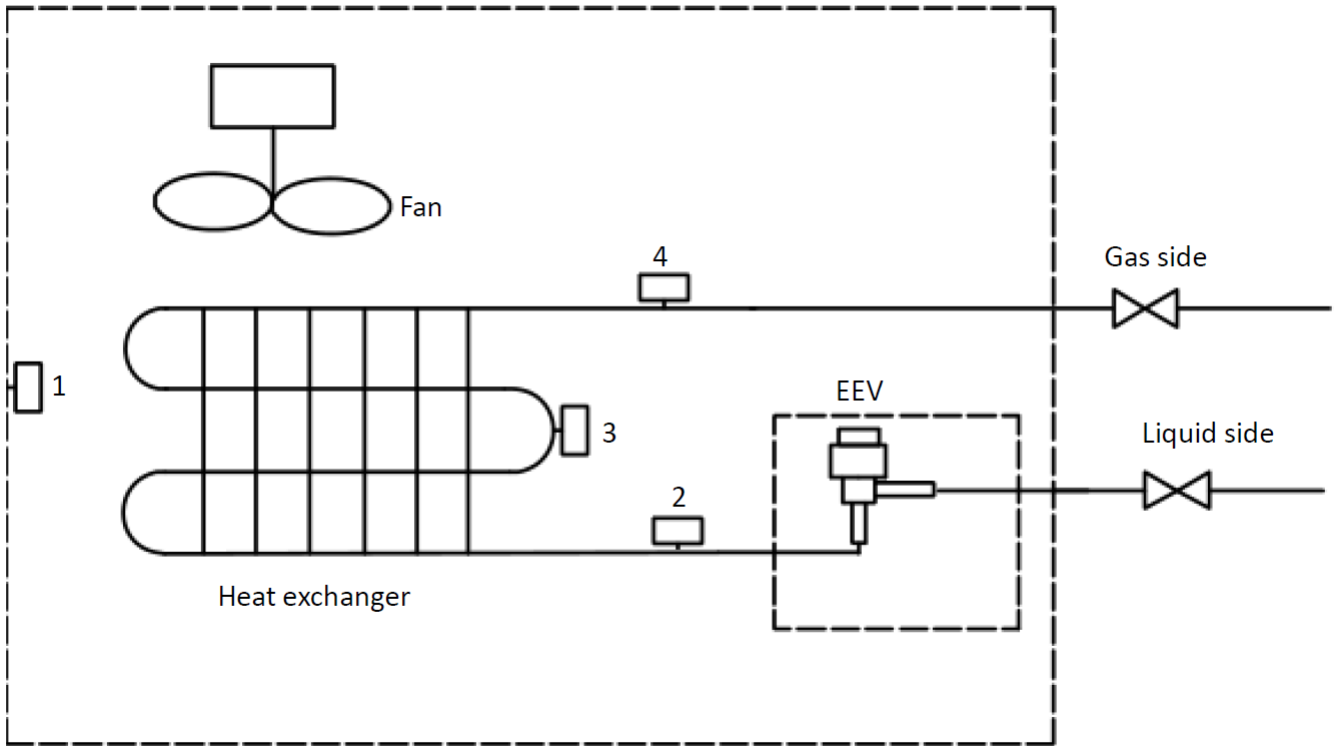

LEGEND		
1	T1	Inlet Air Temp. Sensor
2	T2A	Liquid Pipe Temp. Sensor
3	T2	Middle Pipe Temp. Sensor
4	T2B	Gas Pipe Temp. Sensor
5	EEV	Electronic Expansion Valve
6	FAN	DC Fan Motor

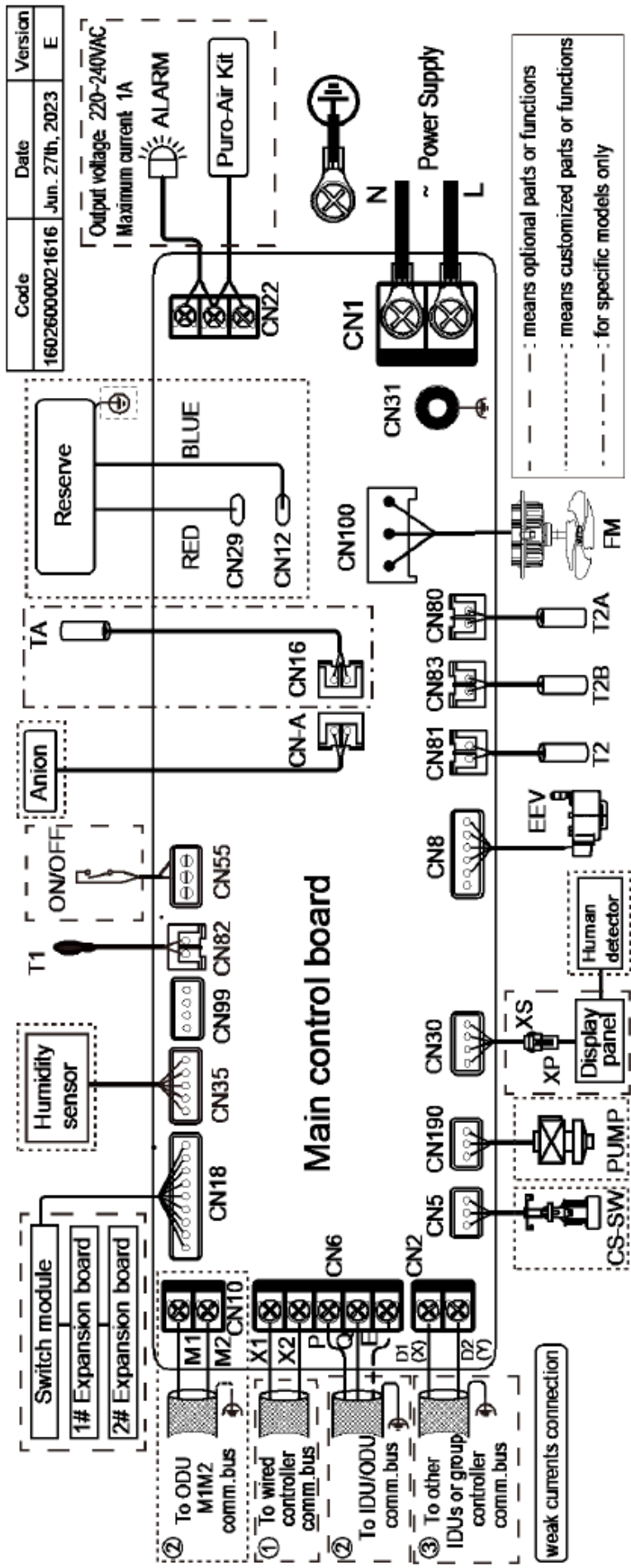

Code	Description	Code	Description
ALARM	Alarm Output	T2	Middle Pipe Temp. Sensor
Anion	Ionic Sterilization Module	T2A	Liquid Pipe Temp. Sensor
CS-SW	Water Level Switch	T2B	Gas Pipe Temp. Sensor
EEV	Electronic Expansion Valve	TA	Discharge Air Temp. Sensor*
FM	DC Fan Motor	ON/OFF	Remote ON/OFF
T0	Outdoor Air Temp. Sensor*	XS/XP	Connectors
T1	Inlet Air Temp. Sensor		

* Indicates that this sensor is only available for Fresh Air Processing Unit.

Caution

- All installation , servicing and maintenance must be carried out by competent and suitably qualified, certified and accredited professionals and in accordance with all applicable legislation.
- Units should be grounded in accordance with all applicable legislation. Metal and other conductive components should be insulated in accordance with all applicable legislation.
- Power supply wiring should be securely fastened at the power supply terminals loose power supply wiring would represent a fire risk.
- After installation, servicing or maintenance, the electric control box cover should be closed. Failing to close the electric control box cover risks fire or electric shock.
- The dotted lines indicate the field wiring or optional function
- D1D2 communication ports are used for group control communication. When connecting the group controller, the D1D2 port of the indoor units that are to be group controlled must be connected in daisy chain, and the group controller must be connected to the X1X2 port of one of the indoor units in the group control, and set to group control mode. In addition, D1D2 communication ports can also be connected to the central controller.

Cooling Capacity Table

MODEL	Indoor air temperature (°C WB/DB)													
	14/20		16/23		18/26		19/27		20/28		22/30		24/32	
	TC	SC	TC	SC	TC	SC	TC	SC	TC	SC	TC	SC	TC	SC
Q1DN-3-XY D18	1.6	1.5	1.7	1.5	1.8	1.6	1.8	1.5	1.9	1.5	1.9	1.4	2.0	1.4
Q1DN-3-XY D22	2.0	1.9	2.1	1.9	2.2	1.9	2.2	1.8	2.3	1.8	2.3	1.7	2.4	1.7
Q1DN-3-XY D28	2.5	2.3	2.7	2.4	2.8	2.4	2.8	2.3	2.9	2.3	2.9	2.1	3.0	2.1
Q1DN-3-XY D36	3.2	2.9	3.4	3.0	3.6	3.1	3.6	3.0	3.7	2.9	3.8	2.8	3.9	2.7
Q1DN-3-XY D45	4.0	3.7	4.3	3.8	4.5	3.9	4.5	3.7	4.6	3.6	4.7	3.4	4.8	3.3
Q1DN-3-XY D56	5.0	4.6	5.3	4.7	5.6	4.8	5.6	4.6	5.7	4.5	5.8	4.3	6.0	4.1
Q1DN-3-XY D71	6.3	5.7	6.7	5.9	7.0	5.9	7.1	5.8	7.2	5.7	7.4	5.4	7.6	5.2

Abbreviations:

TC: Total capacity (kW)

SC: Sensible capacity(kW)

Notes:

1.Shaded cells indicate rating condition.

Heating Capacity Table

MODEL	Indoor air temperature (°C DB)					
	16	18	20	21	22	24
	TC	TC	TC	TC	TC	TC
Q1DN-3-XY D18	2.4	2.4	2.2	2.1	2.1	1.9
Q1DN-3-XY D22	2.8	2.8	2.6	2.5	2.4	2.3
Q1DN-3-XY D28	3.4	3.4	3.2	3.1	3.0	2.8
Q1DN-3-XY D36	4.2	4.2	4.0	3.8	3.8	3.5
Q1DN-3-XY D45	5.3	5.3	5.0	4.8	4.7	4.4
Q1DN-3-XY D56	6.7	6.6	6.3	6.1	5.9	5.5
Q1DN-3-XY D71	8.5	8.4	8.0	7.8	7.5	7.0

Abbreviations:

TC: Total capacity (kW)

Notes:

1.Shaded cells indicate rating condition.

Electrical characteristics

MODEL	Power supply					Indoor fan motors		
	Hz	Volts	Min. volts	Max. volts	MCA	MFA	Rated motor output (kW)	FLA
Q1DN-3-XY D18	50	220-240	198	242	0.38	15	20	0.30
Q1DN-3-XY D22	50	220-240	198	242	0.38	15	20	0.30
Q1DN-3-XY D28	50	220-240	198	242	0.39	15	20	0.31
Q1DN-3-XY D36	50	220-240	198	242	0.39	15	20	0.31
Q1DN-3-XY D45	50	220-240	198	242	0.53	15	50	0.42
Q1DN-3-XY D56	50	220-240	198	242	0.58	15	50	0.46
Q1DN-3-XY D71	50	220-240	198	242	0.59	15	50	0.47

Abbreviations:

MCA: Minimum Circuit Amps MFA: Maximum Fuse Amps FLA: Full Load Amps

Note:

Voltage range: Units are suitable for use on electrical systems where voltage supplied to unit terminals is not below or above listed range limits.

Maximum allowable voltage variation between phases is 2%.

Selection wire size based on the value of MCA.

MFA is used to select the circuit breaker and the ground fault circuit interrupter (earth circuit breaker).

Overall

MODEL	Sound pressure levels dB						
	SSH	SH	H	M	L	SL	SSL
Q1DN-3-XY D18	30	28	27	26	25	24	22
Q1DN-3-XY D22	30	28	27	26	25	24	22
Q1DN-3-XY D28	37	36	35	34	32	31	30
Q1DN-3-XY D36	38	37	35	34	32	31	30
Q1DN-3-XY D45	39	37	36	35	34	32	31
Q1DN-3-XY D56	41	39	38	37	36	35	33
Q1DN-3-XY D71	43	41	40	39	37	36	35

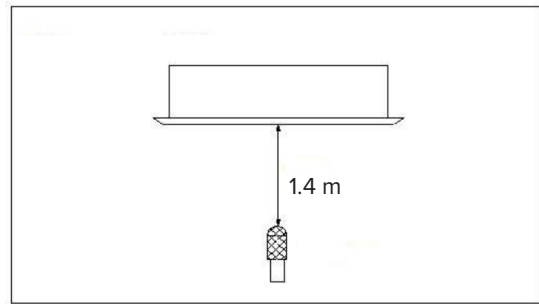

Notes:

1. Sound pressure levels are measured 1.4 m below the unit in a semi-anechoic chamber at 0 Pa. During in-situ operation, sound pressure levels may be higher as a result of ambient noise.

Octave Band Levels

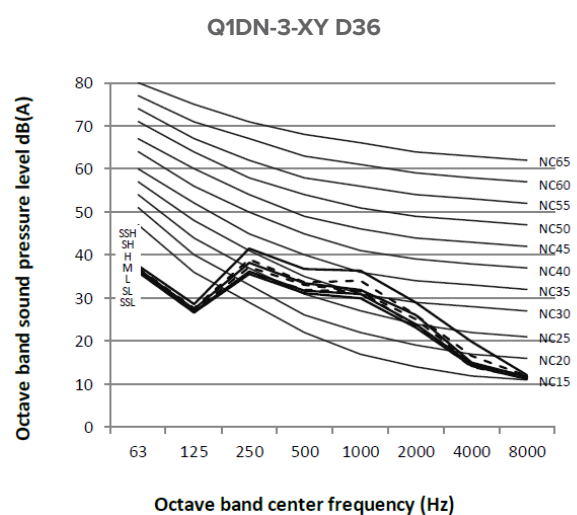
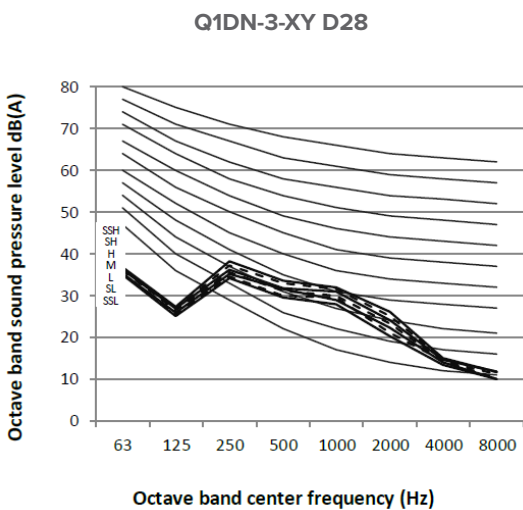
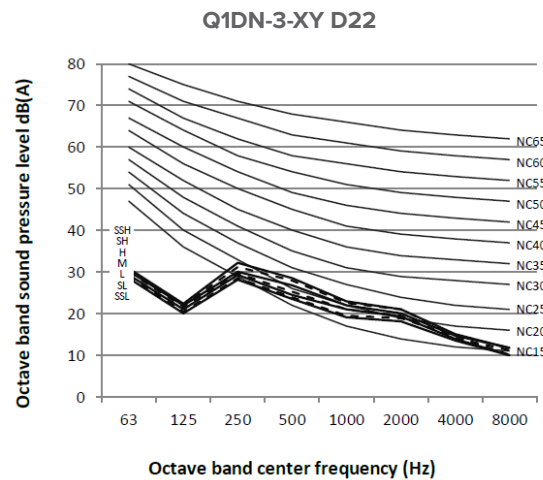
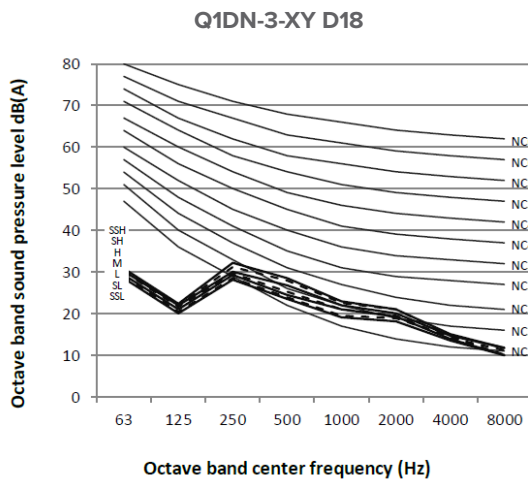

Sound Level

Q1DN-3-XY D45

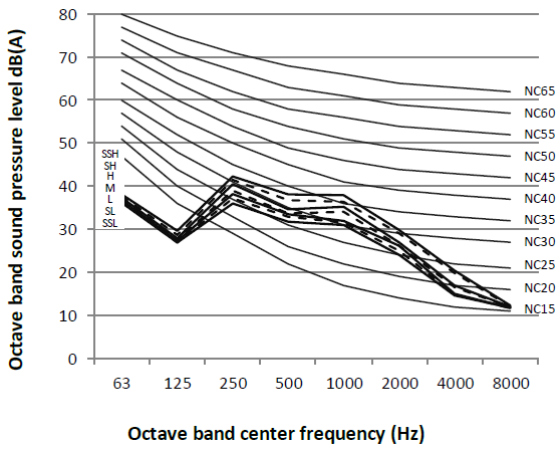

Q1DN-3-XY D56

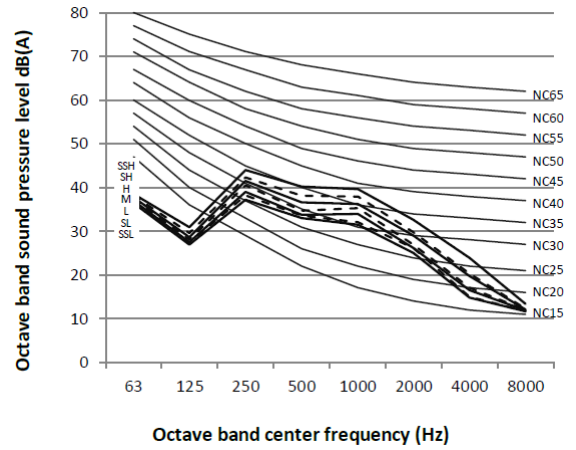

Q1DN-3-XY D71

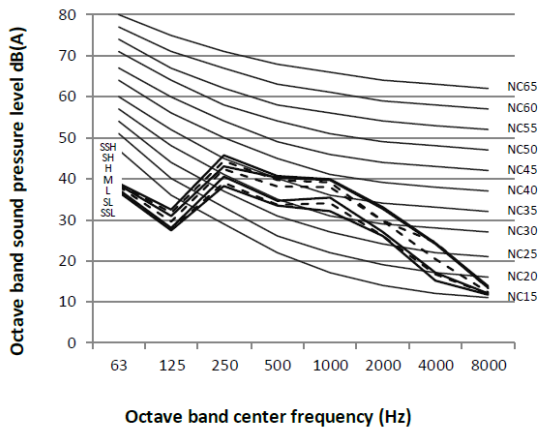

Temperature and Airflow Distributions

Simulate condition

MODEL NAME	Room size (m)	Ceiling height (m)	Flow angle (Cooling/Heating)	Placing
Q1DN-3-XY D18	6x6	2.7	25°/80°	Cassette
Q1DN-3-XY D22	6x6	2.7	25°/80°	Cassette
Q1DN-3-XY D28	6x6	2.7	25°/80°	Cassette
Q1DN-3-XY D36	6x6	2.7	25°/80° </td <td>Cassette</td>	Cassette
Q1DN-3-XY D45	8x8	2.7	25°/80°	Cassette
Q1DN-3-XY D56	8x8	2.7	25°/80°	Cassette
Q1DN-3-XY D71	8x8	2.7	25°/80°	Cassette

Note:

1. These figures and videos are based on software simulation. They show typical temperature and airflow distributions in the conditions above. In the actual installation, they may differ from these figures and videos under the influence of air temperature conditions, ceiling height, cooling/heating load, obstacles, etc.

Airflow distributions - Cooling (after 300s)

Q1DN-3-XY D18

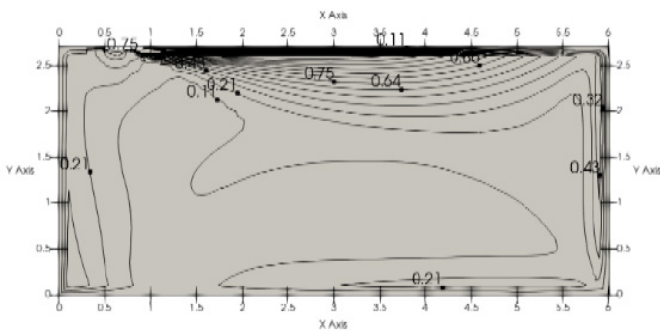

Q1DN-3-XY D22

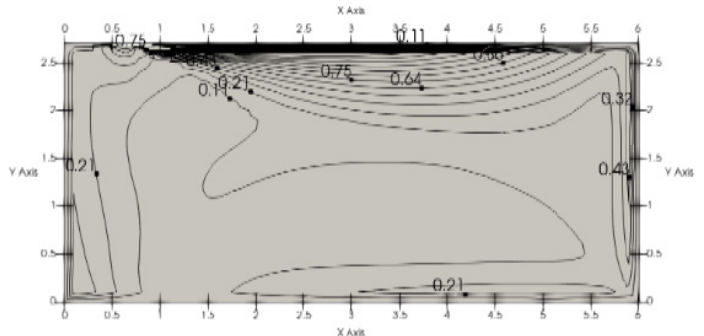

Q1DN-3-XY D28

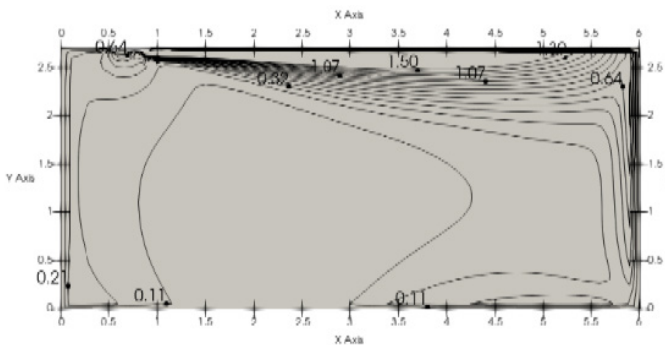

Q1DN-3-XY D36

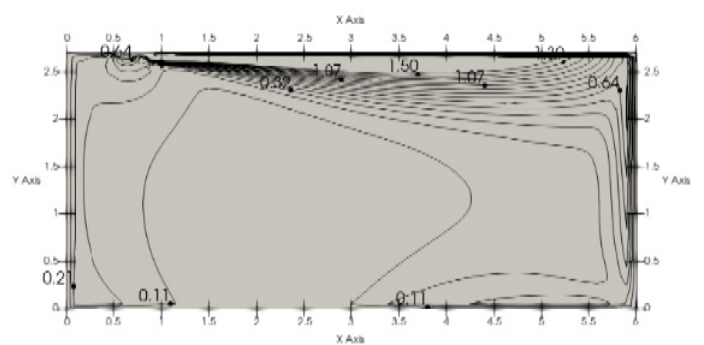

Q1DN-3-XY D45

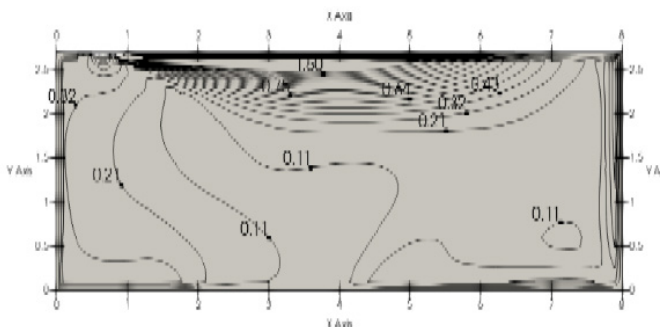

Q1DN-3-XY D56

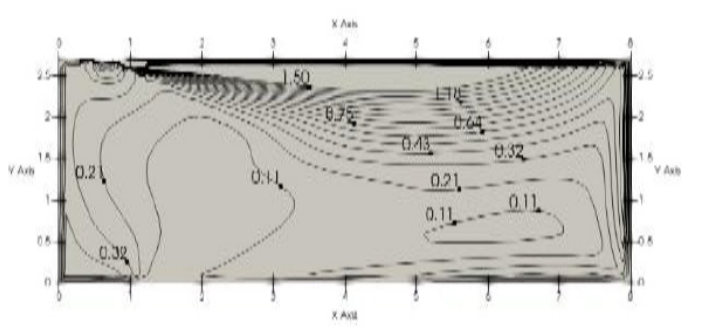

Temperature and Airflow Distributions

Q1DN-3-XY D71

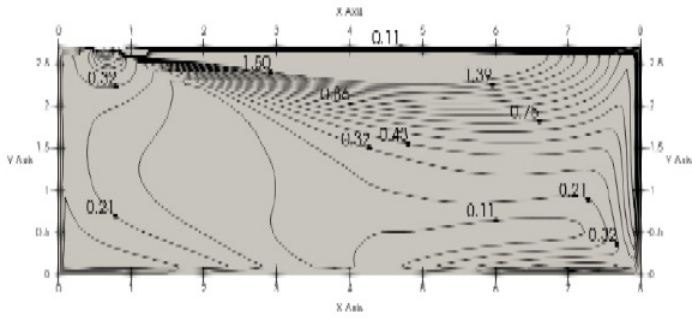

Airflow distributions - Heating (after 300s)

Q1DN-3-XY D18

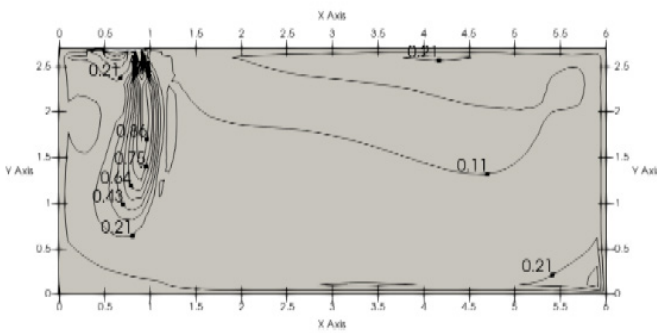

Q1DN-3-XY D22

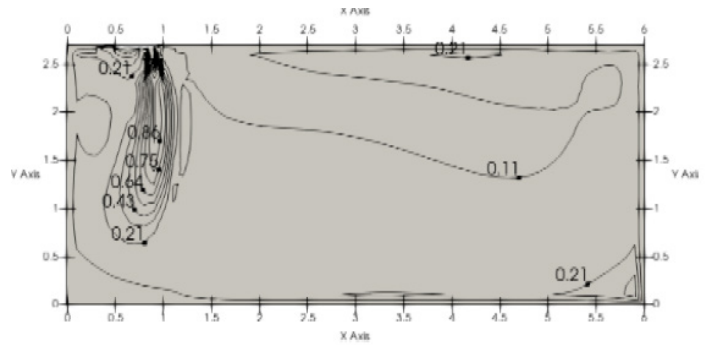

Q1DN-3-XY D28

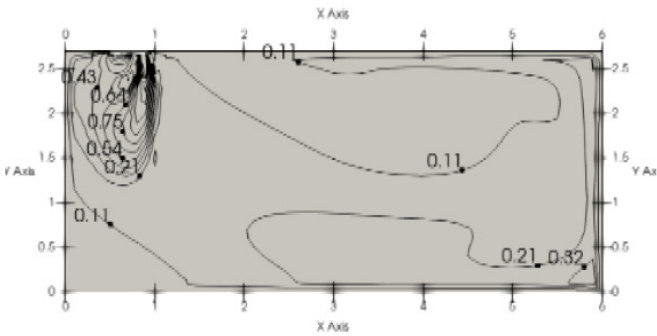

Q1DN-3-XY D36

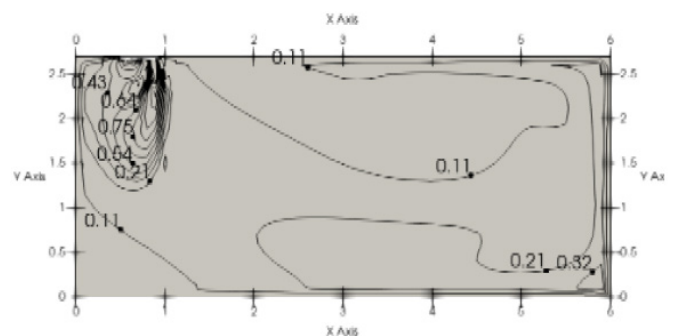

Q1DN-3-XY D45

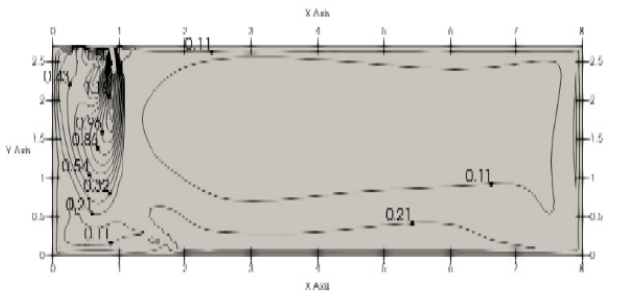

Q1DN-3-XY D56

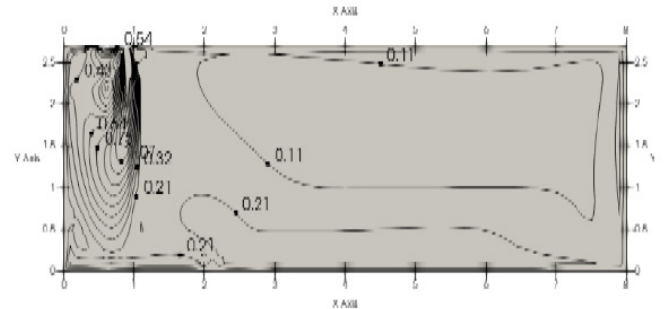

Q1DN-3-XY D71

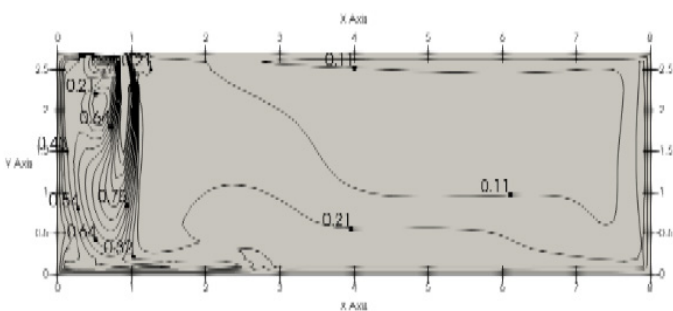

Temperature and Airflow Distributions

Temperature distributions - Cooling (after 300s)

Q1DN-3-XY D18

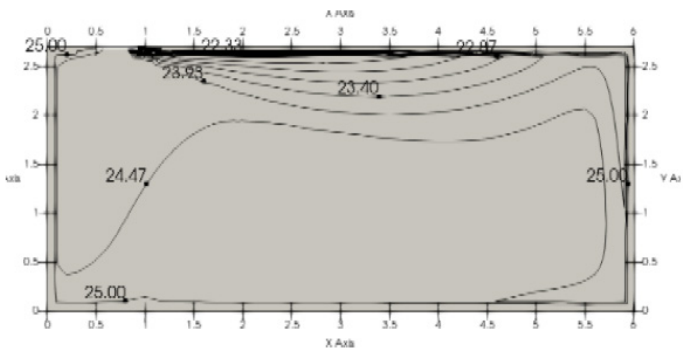

Q1DN-3-XY D22

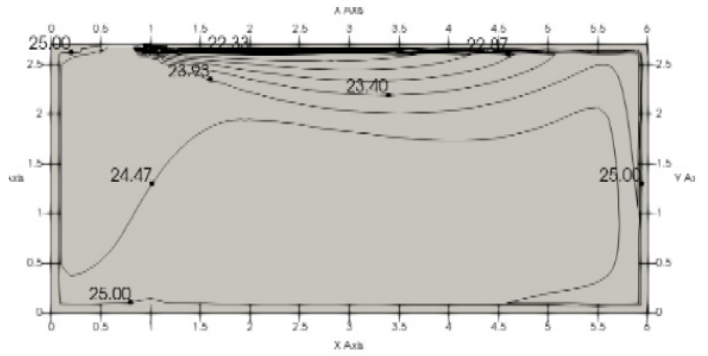

Q1DN-3-XY D28

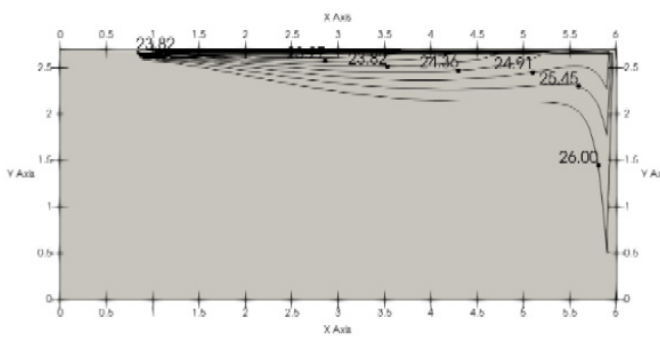

Q1DN-3-XY D36

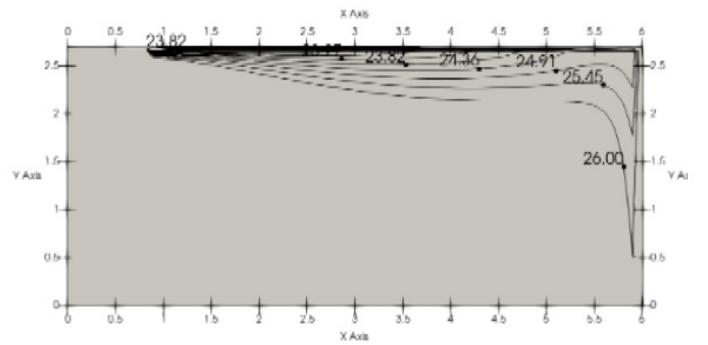

Q1DN-3-XY D45

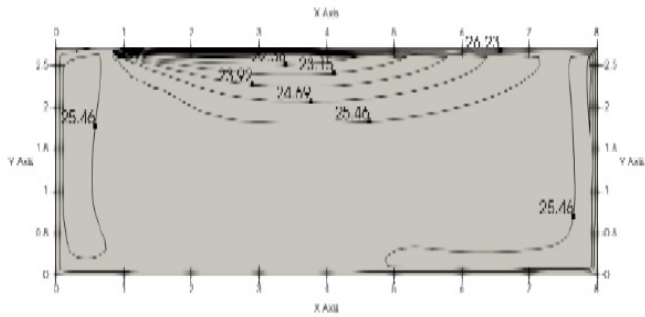

Q1DN-3-XY D56

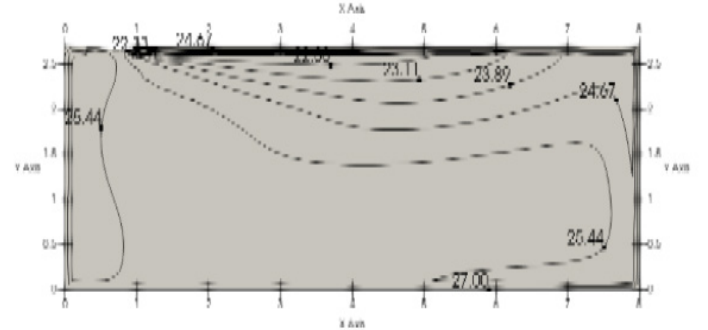

Q1DN-3-XY D71

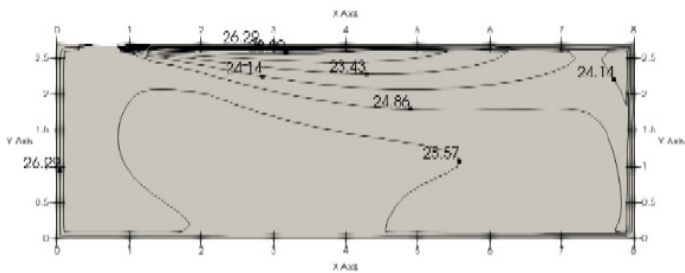

Temperature and Airflow Distributions

Temperature distributions - Heating (after 300s)

Q1DN-3-XY D18

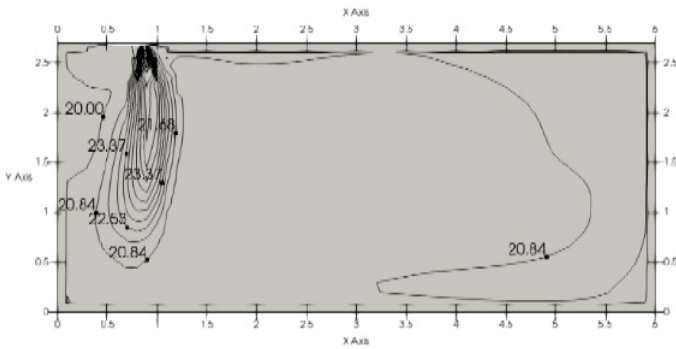

Q1DN-3-XY D22

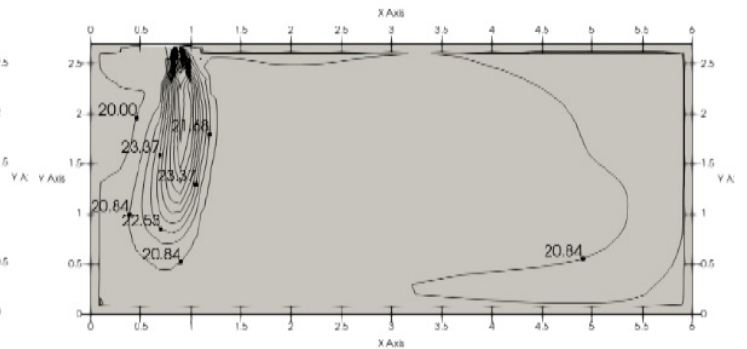

Q1DN-3-XY D28

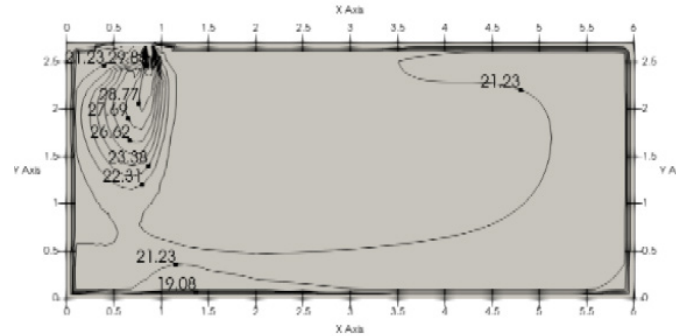

Q1DN-3-XY D36

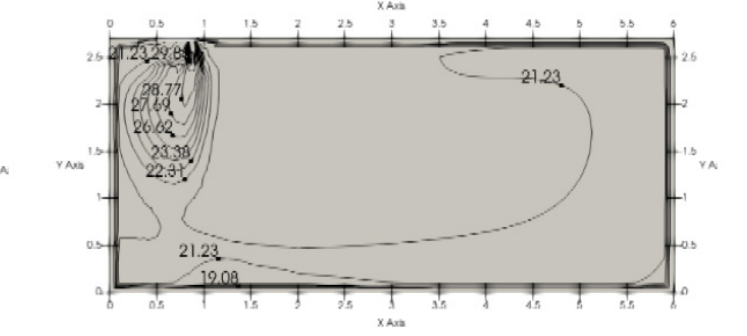

Q1DN-3-XY D45

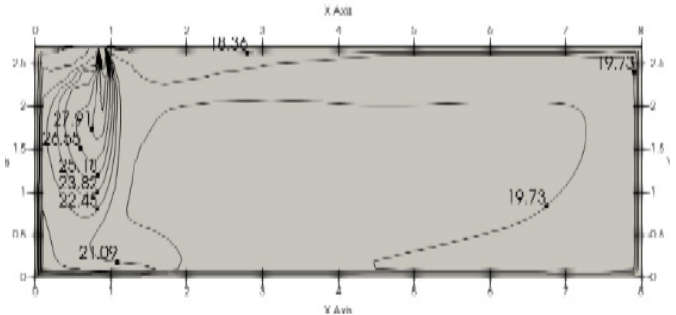

Q1DN-3-XY D56

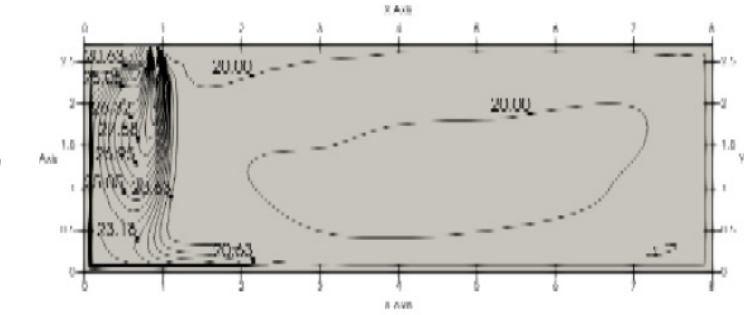

Q1DN-3-XY D71

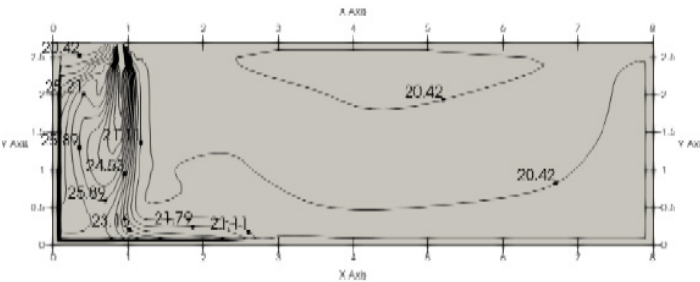



Page intentionally left blank

Page intentionally left blank

FOR 30 YEARS WE HAVE BEEN OFFERING
SOLUTIONS FOR SUSTAINABLE COMFORT
AND THE WELL-BEING OF PEOPLE AND
THE ENVIRONMENT

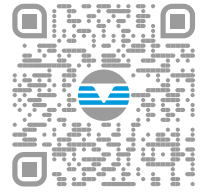

sales and service

www.clivet.com

Valid from: 2023 - (revision 00/2023)
BT23N006GB--00

1-way cassette - Q1DN-3-XY D18 - D71 - BT23N006GB--00



CLIVET S.p.A.

Via Camp Lonc 25, Z.I. Villapaiera 32032 - Feltre (BL) - Italy
Tel. +39 0439 3131 - info@clivet.it

CLIVET GMBH

Hummelsbütteler Steindamm 84,
22851 Norderstedt, Germany
Tel. +49 40 325957-0 - info.de@clivet.com

Clivet Group UK LTD

Units F5 & F6 Railway Triangle,
Portsmouth, Hampshire PO6 1TG
Tel. +44 02392 381235 -
Enquiries@Clivetgroup.co.uk

CLIVET LLC

Office 508-511, Elektroavodskaya st. 24,
Moscow, Russian Federation, 107023
Tel. +7495 6462009 - info.ru@clivet.com

CLIVET MIDEAST FZCO

Dubai Silicon Oasis (DSO) Headquarter Building,
Office EG-05, P.O Box-342009, Dubai, UAE
Tel. +9714 3208499 - info@clivet.ae

Clivet South East Europe d.o.o.

Jarušćica 9b
10000, Zagreb, Croatia
Tel. +3851 222 8784 - info.see@clivet.com

CLIVET France SAS

6 Allée Kepler,
77420 Champs-sur-Marne
France
mail: info.fr@clivet.com
Tel: +33 01 88 60 99 40

Clivet Airconditioning Systems Pvt Ltd

Office No.501 & 502,5th Floor, Commercial -I,
Kohinoor City, Old Premier Compound, Off LBS
Marg, Kiroi Road, Kurla West, Mumbai
Maharashtra 400070, India
Tel. +91 22 30930200 - sales.india@clivet.com